

Transforming e^3 value models into ArchiMate diagrams

Wilco Engelsman

Saxion, University of Applied Sciences
 Enschede, The Netherlands
 w.engelsman@saxion.nl

Roel Wieringa

The Value Engineers
 Amsterdam, The Netherlands
 roel@thevalueengineers.nl

Marten van Sinderen

University of Twente
 Enschede, The Netherlands
 m.j.vansinderen@utwente.nl

Jaap Gordijn

The Value Engineers
 Amsterdam, The Netherlands
 jaap@thevalueengineers.nl

Timber Haaker

Saxion, University of Applied Sciences
 Enschede, Netherlands
 t.haaker@saxion.nl

Abstract—An enterprise architecture (EA) is a high-level representation of an enterprise, used for managing the relation between business and IT. In order to improve the contribution of IT to the business, all elements of an EA should be traceable to the business model and vice versa. However, in practice this is not the case. In addition to reasoning about cost structures and goal contributions of IT to the business, as is customary in EA, traceability would allow practitioners to reason about the contribution of IT to the value offerings of a business. In this research paper we present the results from an experiment where we wanted to refine guidelines for transforming a business model into an EA that we have derived in earlier research. Based on this experiment we refine the guidelines, identify building blocks for a business model (BM) based EA design and illustrate this with an example.

Index Terms—business model, Enterprise Architecture, ArchiMate, e^3 value, traceability

I. INTRODUCTION

An Enterprise Architecture (EA) is a high-level representation of an enterprise designed to operationalize the business strategy of an organization. Large organizations maintain an EA in order to coordinate and steer IT projects and manage IT costs. However, an EA should not only be used to manage IT costs, but also to manage the contribution of IT to the value offerings of an enterprise. This means that an EA should be aligned to the Business Model (BM) of an enterprise. Earlier, we have performed an initial investigation of linking BM designs to the EA [1]. In this current work we extend on that research.

A BM is a conceptual model of how an enterprise creates, delivers and captures value [2]. Today, business models should represent the value network by which an enterprise collaboratively delivers and captures value [3]. We use e^3 value as notation to represent business models [4]. As EA notation we will use ArchiMate [5], including the goal modeling extension [6], [7]. One could say that in this traceability relationship, the BM provides us with the reason why an organization exists

and the initial puzzle pieces, the EA will put these pieces together [8].

We have four main arguments to combine these topics; first, we want to link the value offerings in a BM to the IT of an organization. This way the realized traceability enables us to reason about the financial benefits of an IT system or project. IT needs operational expenses and investments in IT. There is a clear financial relationship.

Second, a BM only focuses on the value offerings of an organization, but not on the technical and organizational feasibility of the BM. By using EA we can focus on organizational and IT design of the value offerings of an organization to determine the feasibility, possibly with standardized patterns of operationalized business models in ArchiMate. We also believe that by linking the business model of an organization to its EA we can evaluate which organizational components contribute the most to the earnings of an organization. This will help organizations in determining which are the most valuable parts of their enterprise.

Third, if wish to construct an ArchiMate model of a **value network**, as we recommend in previous work [3], we need to know the scope of the organizational network we need to model. Therefore, to be able to design an ArchiMate model for this collaboration of actors, we need to determine the focus of the modeling effort.

Fourth, we are also at the beginning of the transition to a circular economy with circular business models. Collaboration between actors in the value network becomes even more important in circular business models [9]–[11], and can be modeled with e^3 value. ArchiMate can be used to investigate feasibility of this collaboration. This paper is structured as follows. Section II, where we introduce our research problem. Section III describes relevant related work, section IV introduces e^3 value and ArchiMate. Section V describes the methodology used. Section VI describes our observations and our new set of guidelines for transforming e^3 value into ArchiMate. We will illustrate our results with a sample application

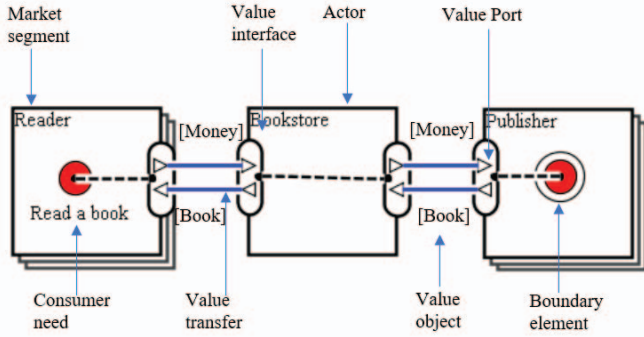

Fig. 1. Educational example e^3value

in section VII and we will conclude with a discussion about validity and future research in section VIII.

II. RESEARCH PROBLEM

The main goal of our research and this experiment is to identify how to translate e^3value models into ArchiMate models. This task is not straightforward, as both languages operate at a different level of abstraction and were designed with a different goal in mind. e^3value focuses on identifying and designing the business services of a networked organization and on analyzing their profitability. ArchiMate focuses on designing the internal organization that realizes the business services. e^3value operates on a value network of multiple actors working together, whereas ArchiMate is designed with a single organization in mind.

An organization is an organized group of people with a particular purpose. A value network of multiple actors can also be seen as an organization working together on a particular purpose, namely delivering value to customers. The difference is that the actors in a value network are economically independent, i.e. each must have a positive cash flow. In addition, a value network can contain competitors, who compete for the same customers. The organization represented by a value network is therefore very complex, ranging from a kind of ad-hoc collaboration to a more stable one. This collaboration could have a shared business strategy and shared business goals. Also the designed organization would also use the same concepts as a single organization (e.g. services, processes, applications, all based on the shared strategy).

First, if we are able to trace from the application to the BM through different ArchiMate layers, we are able to show how an application contributes to the earnings of an organization, which clarifies that IT is not seen as only a cost factor [12]. Second, ArchiMate can be used to model the shared platform needed by the extended organizations in a value network, this would require shared processes, shared IT and a shared infrastructure, all based on the common goals of the organization and strategy.

To address these goals we have conducted an initial conceptual analysis of mapping e^3value to ArchiMate business layer diagrams [1]. Only a mapping to the business layer of

ArchiMate and the motivation layer is required to align these two languages. If a mapping with the business layer is realized, the other layers will automatically be traceable to the BM. In order to test and refine our initial results, we have organized an experiment with practitioners to answer the following research questions:

- Q1: Which types of mistakes do practitioners make in transforming e^3value models into ArchiMate? Why?
- Q2: Which transformation guidelines can we identify based on these mistakes?
- Q3: Which ArchiMate building blocks can we identify based on these guidelines?

Our population of interest consists of conceptual modelers responsible for creating different kinds of organizational models, ranging from value models to EA models. Our goal is not to create formal model-transformation rules that can be automated, in this case a formal transformation is always incomplete. For example, an actor from e^3value can be a role or an actor. The e^3value language itself has some ambiguity in the concept definitions. Therefore, informal guidelines from e^3value to ArchiMate are much more useful as we wish to provide practitioners with understandable tools and guidelines of how to translate an e^3value model into an ArchiMate model.

III. RELATED WORK

The topic of this article is in essence realizing traceability from the EA to business context. In previous work we were involved in extending ArchiMate with goal-oriented concepts [13], [14] to enable goal modeling and reasoning about the contribution of the EA to the business goals of the organization. Related to this is the work of Iacob et al. [15] where they propose a method for IT portfolio evaluation using ArchiMate and the motivation extension. Aldea et al. also propose a way to link EA to the business strategy of the organization [16]. The difference with our work is that this more linked to organizational goals than business models. But it is related in such a way that it realizes traceability to be able to perform different kinds of analysis.

Other relevant related work is done by Pessoa et al. [17] who developed a method for requirements elicitation for business models using an early version of the motivation extension of ArchiMate, but do not use EA notations of ArchiMate. Gordijn et al. propose a method to combine i^* with e^3value , with no focus realizing on traceability [18] and its scope is much smaller than ours. We wish to not only trace to business goals, but also to the EA. Andersson et al. describe the alignment of business models and goals [19]. They have developed templates that align goal statements with value propositions. This is also much smaller in scope than our work and it does not provide transformation guidelines.

Gordijn et al [20] propose a method for requirements engineering for e-services. In this work they take the requirements engineering perspective to design an e-service. They identify different viewpoints and design a service using WSDL and BPEL. This work is of a completely different scope than ours. We stay at a higher level of abstraction to answer different

questions. We wish to link the BM and the EA. De Kinderen, Gaaloul and Proper propose to link ArchiMate to e^3value using an intermediary language. They do not propose a direct mapping [21].

Petrikina et al. [22] propose a preliminary investigation about linking business models with EA at the meta-model level. The authors propose to link the business model to the products and services and create a new meta-model. Our work extends on this with concrete transformation guidelines and modeling examples.

The most recent relevant work is that by The Open Group [23]. They incorporate additional new concepts in ArchiMate, based on the business model canvas (BMC). Meertens et al. propose similar work, but instead of using e^3value they provide a mapping from the Business Model Canvas (BMC) to ArchiMate [24], [25].

Also relevant is the work of Fritscher and Pigneur [26], [27]. They link EA with business models with the BMC as well, but on a very coarse grained level. They do not realize actual traceability to different concepts of different languages nor do they provide guidelines or building blocks. Aldea et al. propose adaptations of ArchiMate to incorporate value modeling [28], but do not try to create traceability between different languages. They also used different concepts to expose the value to the environment (i.e business processes instead of services). We believe that adding more concepts to ArchiMate is not the solution. Adding traceability between the different models (and users) would allow for the same reasoning, without making the language cognitive harder to understand. Also, we believe that business models that do not take the entire value network in to account are of limited use in the future [3], [29].

An application of graph-based semantic techniques to specify, integrate and analyse multiple, heterogeneous enterprise models is explored by Caetano et al. [30]. They use e^3value , ArchiMate and the BMC. The difference with our work is that we focus mainly on guidelines for practioners.

Summarizing, the major difference of our work with related work is our focus on the value network, traceability, extended with transformation guidelines, and building blocks to construct EA models based on the BM.

IV. INTRODUCTION TO e^3value AND ARCHIMATE

In Fig. 1 an educational e^3value model is presented, annotated with the name of the modeling constructs, which we discuss below. In e^3value , an actor is some entity capable of performing value activities, e.g. a business, department or partner. In the example, the book store is an actor.

A market segment (represented by three stacked actors) represents many actors of the same kind. In e^3value this means that all actors in a market segment assign economic value precisely in the same way. A value activity (not shown in the example) is a task performed by an actor which can lead to a positive net cashflow. Value activities differ from activities in process models in e.g. the BPMN. Value activities should be profitable while in BPMN it is perfectly allowed to include

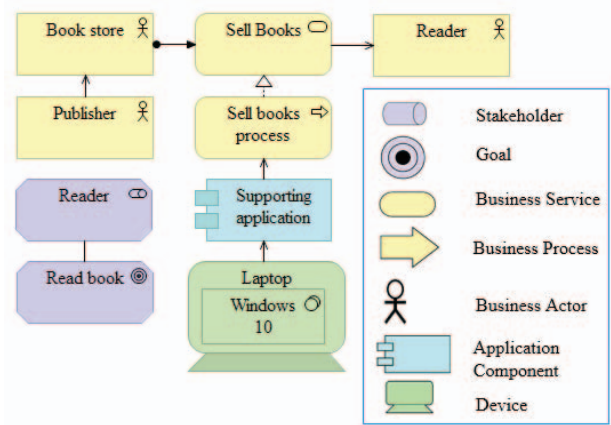

Fig. 2. Educational example ArchiMate

activities that only cost money. Also, value activities are much more related to services than to activities.

Value interfaces represent what the actors offers and requests to/from its environment in terms of value objects. Value objects are things that are perceived by at least one actor as of economic value. A value interface consists of at least one ingoing and one outgoing port, through which the actor requests or offers value objects from or to its environment. The value interface models (1) the notion of economic reciprocity and (2) bundling. Economic reciprocity is the idea that someone only offers something of value, if something else of higher economic value is obtained in return. In the example, a book is exchanged for money, hence the transfers are economically reciprocal. Bundling is the case where it is only possible to offer, or obtain, value objects in combination.

Value ports between actors are connected by means of value transfers, which represent the willingness of actors to exchange things. The value interfaces of one actor may be related by dependency relations, which shows how value objects exchanged via a value interface require or assume exchanges via other value interfaces of that same actor.

An actor can have a consumer need, represented by a bullet. It may also contain a boundary element, which means that we do not model any further exchanges required to fulfill the consumer need. Starting from a consumer need, we can trace all value interfaces triggered by that need to one or more boundary elements. This is called a dependency path.

For example, the sale of a book by the book store requires that this store obtains the book from a publisher.

In Fig. 2 an educational ArchiMate model is presented. ArchiMate is a language for modeling the architecture of enterprises [5]. This allows organizations to design organizational blueprints based on their business strategy and goals. Fig. 2 is a possible ArchiMate model based on the e^3value model of Fig. 1, using our initial guidelines from Table I. We also included a sample application and infrastructure, to show the

holistic approach ArchiMate uses. In this figure we see the central notion of a *sell books* business service, derived from the book store. We modeled the customer as an end user of the service by using the *serves* relation. The book store is responsible, through the *assignment relation*, for exposing the service to the environment. The reader is also included as a stakeholder with a goal *read book*. The business service is *realized* by a selling process *assigned* to the sales person. An application *serves* the process and the application runs on a laptop with Windows 10 (through the *composition relation*). Please note, that this figure is only for illustration purposes. We omitted most of the concepts and relations of ArchiMate [5].

V. RESEARCH METHODOLOGY

An overview of the initial guidelines from our previous research [1] can be found in Table I. We wish to confirm and elaborate on our initial guidelines in an experiment. We did not give our students the initial set of transformation guidelines, as we wanted to test the baseline understanding of the students of transforming these models. That is, we wish to know which concepts or combination of concepts are hard to translate to the similar concepts in ArchiMate. This will give us a precise understanding which concepts mappings are not understood and require help.

Our data comes from a group of practitioners who followed a course on creating an EA with TOGAF. The practitioners had no prior experience in *e³value*, so we taught them the basics of *e³value* modeling. However, they did have prior knowledge of ArchiMate from previous courses and some experience in the field afterwards. The practitioners worked in a broad range of different companies, for example energy providers, telecom providers, the Dutch tax office but also a few smaller sized companies and the defense department. The practitioners all had at least a few years of experience in the organization as a business analyst, functional managers or as administrative employees. At the time of the experiment they were educated at the vocational level, but in their fourth year of their higher vocational education.

This course was part of an evening school for practitioners to obtain their bachelor degree. In the end eight practitioners handed in their assignment, out of 16 students. We disregarded one assignment, because it was of insufficient quality, it did not contain any models to analyze. Seven students passed the course.

We extended this course with value modeling with *e³value* and asked the practitioners to translate their *e³value* model into an ArchiMate business architecture. We only used the results from the students that passed the course and where they scored sufficiently on the *e³value* part. The course was supervised and graded by the first author.

We analyzed the results of their assignment and identified the mistakes made, based on our initial hypotheses set. And based on our analysis we refined guidelines and constructed building blocks of *e³value* that translate into ArchiMate building blocks. Additionally, in working with the results from the

TABLE I
RESULTS OF OUR INITIAL ANALYSIS [1]

Number	Outcome analysis
H1	ArchiMate stakeholders with strategic goals correspond to actors in an <i>e³value</i> model.
H2	Value activities in an <i>e³value</i> model correspond to lower level goals in a strategic ArchiMate goal model.
H3	Consumer needs in an <i>e³value</i> model correspond to lower-level consumer goals in a strategic ArchiMate goal model.
H4	<i>e³value</i> actors map to business actors and possibly roles in an ArchiMate EA model.
H5	<i>e³value</i> value activities map to ArchiMate business services.
H6	<i>e³value</i> value interfaces map to ArchiMate business interfaces
H7	An <i>e³value</i> dependency path may map to a business collaboration in ArchiMate.

experiment we were able to perform an additional conceptual analysis. This also led to three new transformation guidelines, given below. The research protocol and the results from analysis are available at request from the first author. However, the raw data cannot be shared, because of confidentiality reasons. Due to the outbreak of covid-19, combined with the fact the practitioners had to perform their final internship at the same time we were unable to organize closing interviews with the students. Although we did not plan to do so initially, the option of holding them vanished entirely.

VI. RESULTS

A. Observations

We will discuss our observations based on Table I, found in our previous work [1], using the same numbering and description. We will provide hypothetical explanations for our observations.

H1. *ArchiMate stakeholders with strategic goals correspond to actors in an e³value model.* Most of the practitioners modeled the actors from the *e³value* model as stakeholders. This can be explained by the fact that an actor is always a stakeholder by definition. This was understood by the practitioners. However, they could not always understand that both languages operate on different detail levels. Instead of modeling the actor as a stakeholder, they modeled the sub-stakeholders part of a composition, combined with the fact that naming was inconsistent throughout the solutions. For example, in one instance the practitioner modeled his/her company as an actor, but translated this in the ArchiMate model to departments of the company. This can destroy traceability relations. We refined H1 from Table I into G1 and G4 in Table II.

H2. *Value activities in an e³value model correspond to lower level goals in a strategic ArchiMate goal model.* No practitioners modeled value activities as a goal. This points at an error in our previous analysis. We identified a possible match between a business goal (problem domain) and a value activity (solution domain). But, these are two different things at a different layer of abstraction. The relationship is more of the means-end type than of an equivalence type relation. H2 has been removed.

H3. *Consumer needs in an e^3 value model correspond to lower-level consumer goals in a strategic ArchiMate goal model.* Some of the practitioners modeled consumer needs as goals. However, they did not always indicate they were the same goals. So there were deviations in the names. It was interesting to see that the goals were often part of a larger goal tree. The practitioners did understand that goal modeling resulted in more elaborate models. We refined H3 (Table I) into G2 (Table II).

H4. *e^3 value actors map to business actors and possibly roles in an ArchiMate EA model.* Most practitioners were able to model at least some of the actors from e^3 value as actors in ArchiMate. Roles were not used. The practitioners did make errors in scope, where they forgot to model the main organization and went into detail too fast. This made the models inconsistent. Actors in e^3 value are legal or natural persons, such as organizations or consumers. These can also be actors in ArchiMate, but ArchiMate additionally represents software and hardware entities as actors. Second, e^3 value does not know the concept of a role. This is also caused by that e^3 value is more abstract and generic than ArchiMate. The difference in scope in the two languages is not always well understood. We refined H4 (Table I) into G5 (Table II).

H5. *e^3 value value activities map to ArchiMate business services.* Value activities from e^3 value without a consumer need associated to it were mostly modeled as a business service in ArchiMate. The explanation for this is that the definitions of a value activity and business service are very similar, the textbook for e^3 value also refers to value activities as services [4]. Naming was not always consistent and some services were forgotten. The naming errors are the result of not providing clear enough guidelines. We refined H5 (Table I) into G6 (Table II) and G10 (Table III).

H6. *e^3 value value interfaces map to ArchiMate business interfaces.* A single practitioner modeled a sequence of value interfaces on a dependency path as a business interface. However, he did so incorrectly (not adhering to ArchiMate modeling guidelines). Modeling business interfaces is not mandatory in ArchiMate, so many practitioners did not bother to model them. Also, our initial analysis outcome is incomplete. In e^3 value, value activities have value interfaces too, but this cannot be modeled in ArchiMate. We changed H6 (Table I) to G7 and G8 (Table II).

H7. *An e^3 value dependency path may map to a business collaboration in ArchiMate.* Not a single practitioner modeled a business collaboration based on a dependency path. However, a single practitioner did model a sequence of business services that was a sequence of value activities in a dependency path. Apparently it was not clear for practitioners how e^3 value dependencies and collaborations translate into ArchiMate constructs. Perhaps, that the difference in scope between the languages, e^3 value models a value network instead of a single organization, was something the practitioners found hard to identify. Our initial analysis outcome was incomplete and needs refinement in adding the sequence of business services. H7 from Table I is refined into G11 and G12 from Table III.

B. Design of guidelines and building blocks

a) *Building block 1:* Based on these guidelines we identified a number of building blocks. Fig. 3 illustrates the first building block. We have used the first four guidelines to construct this block. The first four guidelines are all related into translating the consumer need part of an e^3 value model to the relevant stakeholder models. Guideline G1 and G2 are used to identify the base concepts of stakeholder and goal. Guideline G3 is applied to construct a goal model using the association relation between the actor and the goal. The fourth guideline is there to correct an incorrect e^3 value model. We use these four guidelines to identify building block 1.

b) *Building block 2:* Fig. 4 illustrates the second building block. We have applied guideline G5, for the identification of the business actor, guideline G6 is applied for the identification of the business service. Guideline G7 combines these two, and guideline G8 identifies the *serves* relation from ArchiMate between the end user and the business service. It is important to note that we decided to follow the guideline associated with guide G7 and model the business interface. The business interface is part of the actor and assigned to the business service. Guideline G8 in this case is not broken, because the derived relation is still an assignment relation. If the business interface is not used, then the actor is directly assigned to the service. Guideline G11 can be applied to adapt this building block. Two actors address a single value interface, and corresponding consumer need, with services of their own. The building block can be extended with these additional services and actors.

c) *Building block 3:* The third building block is illustrated in Fig. 5. We have used guideline G9 the design of this block. The focus on this block is the relations that are possible between the value activities and business services. For this reason we have omitted all irrelevant construct in the ArchiMate model to make this clear. Guideline G9 translates a sequence of value activities in a chain of business services in ArchiMate.

d) *Building block 4:* Building block 4 is illustrated in Fig. 6. For space reasons we have omitted the actual relations and variations of the business service, but the label of the business service mentions that it should be a specialized or composed service. Two actors and the partnership from e^3 value work together in a business collaboration. This busi-

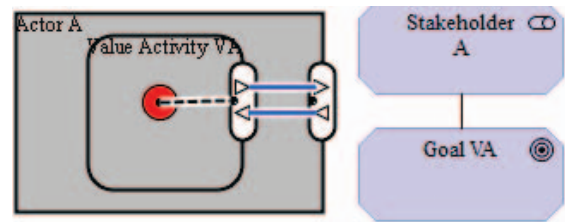

Fig. 3. Building Block 1, derived from guidelines 1-4

TABLE II
OVERVIEW OF GUIDELINES DERIVED FROM THE EXPERIMENT

No	H	Guideline	Additional advice
G1	H1	An e^3 value actor or a market segment can be included as a stakeholder in the ArchiMate motivation layer with the same name.	Additional detail can be added to the stakeholder using the composition or the aggregation relation in ArchiMate.
G2	H3	A consumer need can be modeled as a goal from the ArchiMate motivation layer with the same name as the value activity from e^3 value	Construct a complete and correct goal model if needed.
G3	H1 H3	When the e^3 value actor has a nested value activity and contains a consumer need symbol, this combination can be modeled using stakeholder, goal and association relationship from the motivation layer of ArchiMate.	This is a combination of G1 and G2.
G4	H1	When a e^3 value actor has a need directly associated with it, the actual need is unknown, therefore we only model the stakeholder with the same name.	Complete the goal model from the stakeholder to create a correct goal model.
G5	H4	An e^3 value actor can be at least an ArchiMate business actor with the same name	ArchiMate business actors can be internal or external to the organization itself. In ArchiMate we can identify additional business actors that are part of the same organization. Decompose the business actors when needed.
G6	H5	A value activity, without containing a consumer need, can be modeled as a business service in ArchiMate from the business layer with the same name	Services can be internal or external to the organization itself. Focus on the organization that is being modeled.
G7	H6	When a value activity is nested in an e^3 value actor, this may be modelled in ArchiMate by a business actor, business service and business interface. ArchiMate guidelines can be followed for the relations between them.	As an alternative to business actors, business roles can be used instead of the business actor, if the role is responsible for delivering the business service. See G10.
G8		If an e^3 value actor contains a consumer need and is linked to a value activity as described in G7, this can be an end user of the business service in ArchiMate and then a serving relation is used between the business actor and the business service.	
G9	H7	When there is a trace through the dependency path, including and/or dependencies, this trace must be represented as well in ArchiMate through the business services if the trace contains value activities.	There are different relations in ArchiMate a) triggering, b) information flow, c) serves relation, d) a combination. Use ArchiMate guidelines to identify the correct one.

TABLE III
OVERVIEW OF GUIDELINES DERIVED FROM ADDITIONAL CONCEPTUAL ANALYSIS

No	H	Guidelines	Additional advice
G10	H6	If there are different types of a single actor in e^3 value which are responsible for performing different kinds of behavior, then consider a business role in ArchiMate. Value activities in an e^3 value actor can lead to different roles of an ArchiMate business actor.	Actors in e^3 value often are roles.
G11	H7	If two e^3 value actors address a single value interface to address a consumer need, then use a business collaboration	Investigate the dependency path to determine if we have a collaboration of multiple companies. Name the actors accordingly to the e^3 value model. Name the business collaboration using the ArchiMate standards.
G12	H7	If two actors bundle their interfaces in a partnership, then a business collaboration and a specialized business service combined with a business collaboration can be used.	

ness collaboration delivers a specialized service. Instead of two companies delivering two services to a single customer, they combined their services. Guideline G12 is used for this. If there are more actors involved in this partnership, the building block has to be extended with this.

Guideline G10 is used to transform an actor into roles in ArchiMate. This is an alternative for guideline G1. We will not include a building block for this, since this is not an aggregate guideline set.

C. Answers to research questions

Q1: Which type of mistakes did the practitioners make in transforming e^3 value models into ArchiMate? Why? The practitioners made in general two types of mistakes, which were probably caused by the different scope of both languages and the complexity of a value network. For example, practitioners forgot to model a high level actor as a stakeholder, but did model elements that could be part of a stakeholder decomposition, without the top stakeholder. Second, translating a value network (e.g. a chain of services) was also hard for the practitioners.

Q2: Which guidelines can we identify based on these mistakes? We were able to identify 12 guidelines based on the

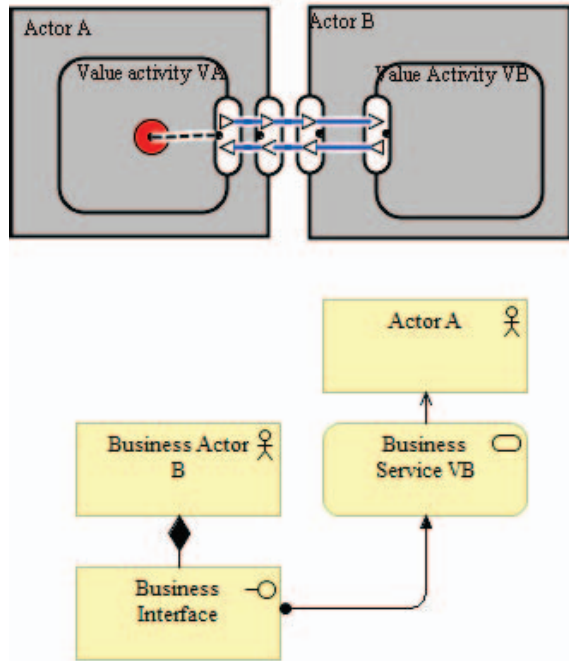

Fig. 4. Building Block 2, derived from guidelines 5-8

experiment and the following additional conceptual analysis. Table II and Table III answer this research question.

Q3: Which ArchiMate building blocks can we identify based on these guidelines? We were able to identify four building blocks, illustrated in Fig. 3 through Fig. 6. These figures answer our third research question.

VII. APPLICATION

We illustrate our guidelines by applying them on our example case of Cirque du Soleil. Fig. 7 illustrates our e^3 value model and Fig. 8 our resulting ArchiMate model. The central actor here is Cirque Du Soleil, their value activity is to perform a live show. Visitors have a consumer need to enjoy a live artistic show and the consumer satisfies this need by paying Cirque du Soleil for performing. Cirque du Soleil hires a

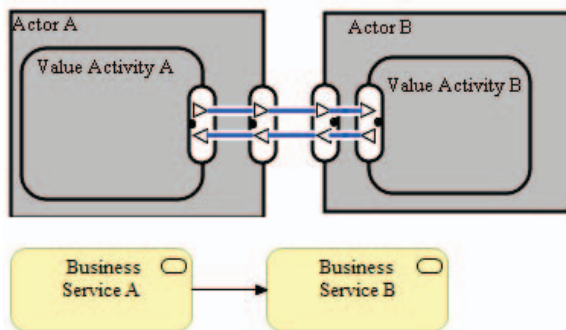

Fig. 5. Building Block 3, derived from guidelines 9

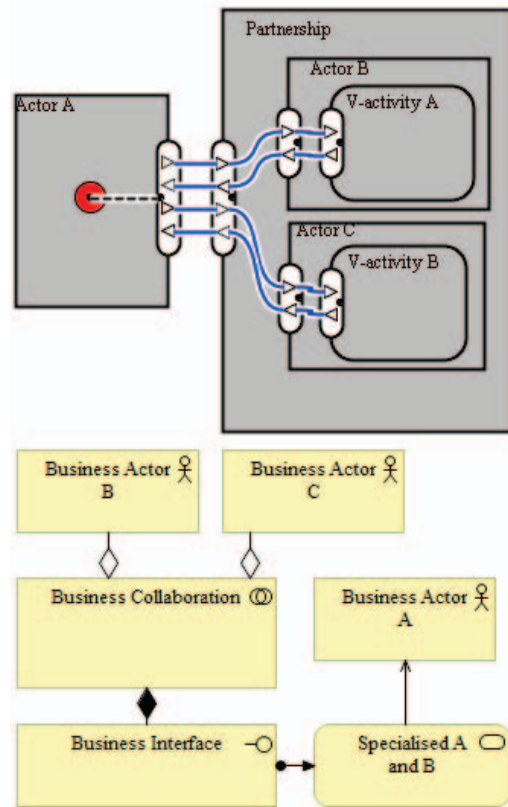

Fig. 6. Building Block 4, derived from guidelines 11 and 12

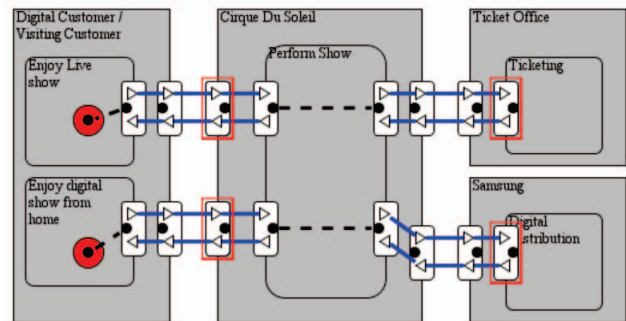

Fig. 7. e^3 value model Cirque Du Soleil

ticket office to sell tickets. Samsung enters into a possible collaboration with Cirque Du Soleil to distribute the VR media of the circus performance to customers. An external ticket office is used to offer a ticketing service.

In our example we modeled a single customer with two value activities. The customer and the value activities translate to the stakeholder customer with a goal enjoying the live show. This follows guidelines G1, G2 and G3. The customer is also translated to a business actor, therefore applying guideline G5. Guidelines G6, G7, G8 and G9 are also used in the example. Cirque Du Soleil has a value activity to perform a show. We

A. Validity

Internal validity is the support for our hypothetical explanations of the phenomena. Could subjects have misunderstood some concepts for other reasons than the ones we hypothesize? Because our previous work is published, we can not guarantee they did not use our previous transformation guidelines. However, the first author did ask during the last lecture if any practitioners used our previous results and the answer was negative.

External validity is the support for generalization from our quasi-experiment. Generalization to other languages is not our goal. Their homework was an exercise based on an actual problem in their organization. These were real design problems in the organization and therefore a fair representation of the difficulty level. However, this does not mean that we can generalize to all realistic problems. We created a first refinement of our guidelines, future applications might introduce additional refinements (i.e. other problems from practice can introduce different models with different guidelines).

The participants of the group self-selected into the course and so they may be more motivated or more talented than the ‘average’ business analyst. They were also highly motivated to pass this course, since this was the last course before they could start their bachelor thesis assignment and their company paid for this course. Not passing would reflect badly on the practitioners and would weaken their position in their organization. Based on this generalization to other practitioners is not possible.

However, using this experiment we could identify points of improvement for our hypotheses. We motivated every resulting guideline in terms of the semantics of e^3value and ArchiMate, and this motivation ensures applicability to other cases in which these two languages are applied.

A second issue might be that the students constructed an EA based on their knowledge of the actual problem instead of the e^3value business model. We do not believe that this is the case, since the e^3value and ArchiMate models were quite similar.

B. Applicability

We envision a number of different applications for this EA designing approach. First, we can relate, through the business service to value activity mapping, the IT systems of an organization to the earnings of an organization. This would allow us to provide qualitative reasoning about the contribution of IT to the financials of an organization. Quantitative reasoning is still beyond the scope of the current guidelines. It is possible to follow the relations from IT to the value offerings, but there are different kinds of relations. We first would need to determine how to treat these different kind of relations in an ArchiMate model.

Second, a good BM has to be practically feasible and economically viable. Traceability to an EA will help assess both feasibility and viability. In addition, organizations need

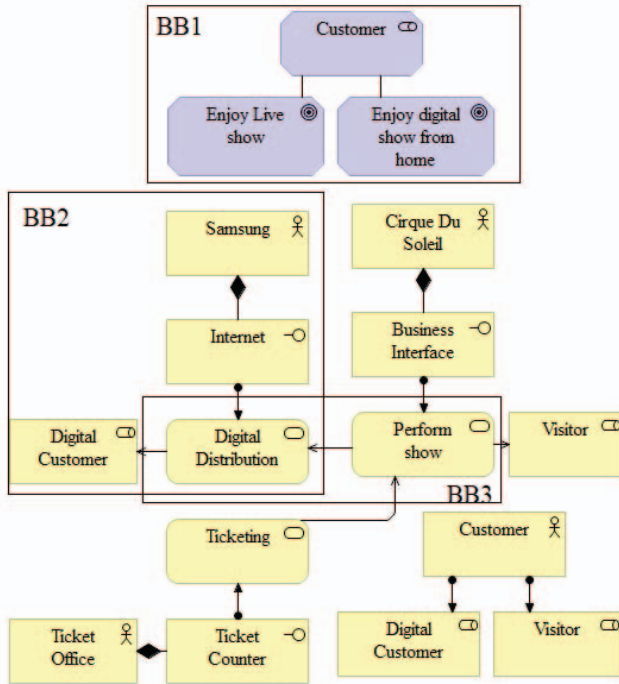

Fig. 8. Resulting ArchiMate model

can therefore identify a similarly named business service in ArchiMate. Since the value activity is nested, we also need to show this in ArchiMate. This is done by modeling the actor Cirque Du Soleil and (indirectly) *assigning* this to the service. We have chosen to include a business interface. We applied guidelines G6, G7, G8, G9. The value activity of Cirque Du Soleil is linked to the visitor. Which is an external stakeholder with a consumer need. Therefore in ArchiMate we model this as a *serves* relation between the business service and the external actor. If we investigate the value activities in the actor visitor, we can also apply guideline G10.

The two value activities denote two possible roles the actor can perform (visiting or watching from home). This is illustrated by G10. Guideline 11 is not applicable here, because the Ticket Office and Samsung deliver to Cirque Du Soleil and not directly the consumer need. These services are supporting for the main service. We have illustrated three building blocks in Fig. 8. Building Block 1 is the, simplified, goal model. Building Blocks 2 and 3 illustrate the modeling patterns we identified by applying the rules.

Traceability is realized through the mapping of the business service in ArchiMate to the value activity of e^3value . This way we can trace the relations of the infrastructure, application and business layers into the business model. This enables reasoning about the contribution of IT to the BM of Cirque Du Soleil and shows what IT architecture is needed to realize the BM. This would require finishing the EA model into the application and infrastructure layers, which we have chosen to omit in this paper.

to start thinking of aligning their EA with a shared EA based on the entire value network. Our technique would allow us to design the shared aspects of this collaboration.

Third, we can operationalize a BM of an organization into ArchiMate business layer diagrams. If we apply this often enough we can derive organizational patterns that operationalize business models. This would be an addition to the work of reference architectures, but instead from a bottom up perspective we can derive them from a top down manner.

Finally, a circular BM is a specialized version of the value network. No longer can organizations take the single organization perspective. In a circular BM, the entire value network has to be taken into account. This would require services of different organizations in the value network to be aligned together [9]. Our technique can help in determining the feasibility of this and operationalize this. If we apply this technique often enough we can also derive patterns, like for a single organization, for the value network, including for circular business models.

C. Limitations and Future work

There are a few clear limitations of this work. Although we have derived our transformation guidelines from a set of different business models, we still need to them apply in practice. No practitioners have used our guidelines. The aspect of business value to the realized traceability is not yet evaluated either. However, from a conceptual analysis point of view, this is now technically possibly due to the mapping between value activities and business services.

Currently the first author is involved in a validation study in practice to see if the guidelines are useful and to further investigate the reasons we introduced in the introduction of this paper. The case study is at a scale up company that acquires intellectual property, acquires the right people, acquires capital from venture capitalists and then matures the company so it can be sold to venture capitalists who wish to perform a low risk investment. We will construct an e^3value model, combined with quantification of the value exchanges. We will apply the transformation rules, identify the building blocks and redesign their business architecture and link their application architecture to the business architecture. We plan to hold semi-structured interviews to evaluate the business value of this traceability. After this case study we plan to refine the guidelines one last time and then validate the guidelines by teaching them to practitioners. In this experiment we would let practitioners in a semi realistic setting, their own organization, apply the guidelines on the business models of their own organization. We will conduct semi-structured interviews afterwards to determine if the guidelines were useful.

There is also no methodological support to align both phases of business model design and EA design. It is important that both disciplines are aligned together, similarly as TOGAF does in their ADM for EA design, EA governance and project management [32]. We also plan to organize small research projects where students will apply these rules on existing e^3value models and derive business service architectures from

this. We wish to investigate these to identify refinements to our building blocks. We wish to investigate the variations that are possible to determine a more robust set of guidelines and building blocks. We also wish to adapt e^3value to circular business models and update our guidelines for accordingly, if needed. We also plan to extend this work with designing a governance organization that steers the value network into achieving its shared goals [3]. We need to incorporate some peer to peer governance techniques for this [31]. And finally we wish to develop a tool where both e^3value models and ArchiMate models can be linked together and maintained. This tool would also enable us to implement the different forms of analysis we envision by combining e^3value and ArchiMate.

REFERENCES

- [1] W. Engelsman, R. J. Wieringa, M. van Sinderen, J. Gordijn, and T. Haaker, "Realizing traceability from the business model to enterprise architecture," in *International Conference on Conceptual Modeling*, Springer, 2019, pp. 37–46.
- [2] A. Osterwalder and Y. Pigneur, *Business model generation: a handbook for visionaries, game changers, and challengers*. John Wiley & Sons, 2010.
- [3] R. Wieringa, W. Engelsman, J. Gordijn, and D. Ionita, "A business ecosystem architecture modeling framework," in *2019 IEEE 21st Conference on Business Informatics (CBI)*, IEEE, vol. 1, 2019, pp. 147–156.
- [4] J. Gordijn and J. M. Akkermans, *Value Webs: Understanding E-business Innovation*. The Value Engineer, 2018, <http://www.thevalueengineers.nl>.
- [5] The Open Group, *ArchiMate 2.0 Specification*. Van Haren Publishing, 2012.
- [6] W. Engelsman and R. Wieringa, "Understandability of goal concepts by requirements engineering experts," in *International Conference on Conceptual Modeling*, Springer, 2014, pp. 97–106.
- [7] —, "Goal-oriented requirements engineering and enterprise architecture: Two case studies and some lessons learned," in *Requirements Engineering: Foundation for Software Quality*, Springer, 2012, pp. 306–320.
- [8] D. J. Teece, "Business models, business strategy and innovation," *Long range planning*, vol. 43, no. 2-3, pp. 172–194, 2010.
- [9] V. Ranta, L. Aarikka-Stenroos, and S. J. Mäkinen, "Creating value in the circular economy: A structured multiple-case analysis of business models," *Journal of cleaner production*, vol. 201, pp. 988–1000, 2018.
- [10] M. Lewandowski, "Designing the business models for circular economy—towards the conceptual framework," *Sustainability*, vol. 8, no. 1, p. 43, 2016.
- [11] M. Moreno, C. De los Rios, Z. Rowe, and F. Charnley, "A conceptual framework for circular design," *Sustainability*, vol. 8, no. 9, p. 937, 2016.
- [12] N. Venkatraman, "Beyond outsourcing: Managing it resources as a value center," *MIT Sloan Management Review*, vol. 38, no. 3, p. 51, 1997.
- [13] D. A. C. Quartel, W. Engelsman, H. Jonkers, and M. J. van Sinderen, "A goal-oriented requirements modelling language for enterprise architecture," in *Proceedings of the Thirteenth IEEE International EDOC Enterprise Computing Conference, EDOC 2009, Auckland, New Zealand*, Auckland, New Zealand: IEEE Computer Society Press, 2009, pp. 3–13.

- [14] W. Engelsman, D. A. C. Quartel, H. Jonkers, and M. J. van Sinderen, "Extending enterprise architecture modelling with business goals and requirements," *Enterprise information systems*, vol. 5, no. 1, pp. 9–36, Feb. 2011, ISSN: 1751-7575.
- [15] M.-E. Iacob, D. Quartel, and H. Jonkers, "Capturing business strategy and value in enterprise architecture to support portfolio valuation," in *2012 IEEE 16th International Enterprise Distributed Object Computing Conference*, IEEE, 2012, pp. 11–20.
- [16] A. Aldea, M.-E. Iacob, and D. Quartel, "From business strategy to enterprise architecture and back," in *2018 IEEE 22nd International Enterprise Distributed Object Computing Workshop (EDOCW)*, IEEE, 2018, pp. 145–152.
- [17] R. M. Pessoa, M. van Sinderen, and D. A. Quartel, "Towards requirements elicitation in service-oriented business networks using value and goal modelling.," in *ICSOF (2)*, 2009, pp. 392–399.
- [18] J. Gordijn, E. Yu, and B. Van Der Raadt, "E-service design using i* and e/sup 3/value modeling," *IEEE software*, vol. 23, no. 3, pp. 26–33, 2006.
- [19] B. Andersson, M. Bergholtz, A. Edirisuriya, T. Ilayperuma, P. Jayaweera, P. Johannesson, and J. Zdravkovic, "Enterprise sustainability through the alignment of goal models and business models," in *Proceedings of 3rd International Workshop on Business/IT-Alignment and Interoperability (BUSITAL'08) CEUR Workshop Proceedings*, 2008.
- [20] J. Gordijn, P. Van Eck, and R. Wieringa, "Requirements engineering techniques for e-services," *Service-Oriented Computing: Cooperative Information Systems Series*, pp. 331–352, 2009.
- [21] S. de Kinderen, K. Gaaloul, and H. A. Proper, "Bridging value modelling to archimate via transaction modelling," *Software & Systems Modeling*, vol. 13, no. 3, pp. 1043–1057, 2014.
- [22] J. Petrikina, P. Drews, I. Schirmer, and K. Zimmermann, "Integrating business models and enterprise architecture," in *2014 IEEE 18th International Enterprise Distributed Object Computing Conference Workshops and Demonstrations*, IEEE, 2014, pp. 47–56.
- [23] E. Walters, "Modeling the business model canvas with the archimate specification," 2020.
- [24] L. O. Meertens, M.-E. Iacob, L. J. Nieuwenhuis, M. J. van Sinderen, H. Jonkers, and D. Quartel, "Mapping the business model canvas to archimate," in *Proceedings of the 27th annual ACM symposium on applied computing*, ACM, 2012, pp. 1694–1701.
- [25] M.-E. Iacob, L. O. Meertens, H. Jonkers, D. A. Quartel, L. J. Nieuwenhuis, and M. J. Van Sinderen, "From enterprise architecture to business models and back," *Software & Systems Modeling*, vol. 13, no. 3, pp. 1059–1083, 2014.
- [26] B. Fritscher and Y. Pigneur, "Business it alignment from business model to enterprise architecture," in *International Conference on Advanced Information Systems Engineering*, Springer, 2011, pp. 4–15.
- [27] —, "Business it alignment between business model and enterprise architecture with a strategic perspective," *International Journal of Information System Modeling and Design*, vol. 6, no. 1, pp. 1–23, 2015.
- [28] A. Aldea, M. E. Iacob, J. van Hillegersberg, D. Quartel, and H. Franken, "Modelling value with archimate," in *International Conference on Advanced Information Systems Engineering*, Springer, 2015, pp. 375–388.
- [29] V. Mayer-Schönberger and T. Ramge, *Reinventing capitalism in the age of big data*. Basic Books, 2018.
- [30] A. Caetano, G. Antunes, J. Pombinho, M. Bakhshandeh, J. Granjo, J. Borbinha, and M. M. Da Silva, "Representation and analysis of enterprise models with semantic techniques: An application to archimate, e3value and business model canvas," *Knowledge and Information Systems*, vol. 50, no. 1, pp. 315–346, 2017.
- [31] F. Kaya, J. Gordijn, R. Wieringa, and M. Makkes, "Governance in peer-to-peer networks is a design problem," in *14th International Workshop on Value Modelling and Business Ontologies, VMBO 2020*, CEUR-WS, 2020, pp. 125–132.
- [32] The Open Group, *TOGAF Version 9*. Van Haren Publishing, 2009.