

A Majority Vote, Modelled by Asynchronous Readers and Asynchronous Writers

Antoon H. Boode^{a,b,1}, and Jan F. Broenink^a

^a *Robotics and Mechatronics,*

*Faculty of Electrical Engineering, Mathematics and Computer Science,
University of Twente, the Netherlands*

^b *InHolland University of Applied Science, the Netherlands*

Abstract. Reading and writing is modelled in CSP using actions containing the symbols ? and !. These reading actions and writing actions are synchronous, and there is a one-to-one relationship between occurrences of pairs of these actions. In the CPA conference 2017, we introduced the extended half-synchronous alphabetised parallel operator $X \Downarrow Y$, which disconnects the writing to and reading from a channel in time; the reading processes are divided into sets which are set-wise asynchronous, but intra-set-wise synchronous, giving full flexibility to the reads.

In this paper, we allow multiple writers to write to the same channel set-wise asynchronously, but intra-set-wise synchronously and we study the impact on our (Extended) Vertex Removing Synchronised Product. The advantages we accomplish are that the extension of $X \Downarrow Y$ gives more flexibility by indexing the writing actions and the reading actions, leading to a straightforward majority vote design. Furthermore, the extension of $X \Downarrow Y$ preserves the advantages of the $X \Downarrow Y$ operator.

Keywords. CSP, Half-Synchronous Alphabetised Parallel Operator, Asynchronous and Synchronous Write Actions, Asynchronous and Synchronous Read Actions, (Extended) Vertex Removing Synchronised Product

Introduction

Periodic Hard Real-Time Control Systems (PHRCSs) modelled using process algebras comprise many short processes, which leads to fine-grained concurrency. Because of this fine-grained concurrency and the many short processes we introduced in [1] a software architecture which controls the behaviour of the PHRCSs by directed graphs².

To let the PHRCS perform its task as required by the specification, the processes synchronise over actions, asserting a certain order of the actions of the processes. A special case of this synchronisation over actions is the notion of writing to and reading from a channel, which was introduced in [4]. This writing to and reading from a channel is synchronous.

¹Corresponding Author: *Ton Boode, Robotics and Mechatronics, CTIT Institute, Faculty EEMCS, University of Twente, P.O. Box 217 7500 AE Enschede, The Netherlands. Tel.: +31 631 006 734; E-mail: a.h.boode@utwente.nl.*

²Due to this architecture described in [2], we do not need models like failures models and traces models such as given by [3].

In [5] and [6] we have introduced the (extended) half-synchronous alphabetised parallel operator, which disconnects the writing to and reading from a channel. The writing to a channel by more than one process was inhibited in [5], but relaxed to synchronous writing in [6]. In this paper, we relax these restrictions further; the writing processes are divided into sets which are set-wise asynchronous, but intra-set-wise synchronous, giving full flexibility to the asynchronous writing and reading actions. In this manner we are able to model a majority vote using this enhanced operator, together with the indexed writing and reading actions. Note that we still require our graphs to be pairwise consistent (defined in Definition 1) to ensure that pathological cases like a deadlock are avoided.

The idea is quite simple. Let the processes P_1 , P_2 and P_3 contain a writing action $c_i x : T$. Then by indexing this writing action for process P_1 with the indices 1, 2, for process P_2 with the indices 2, 3 and for process P_3 with the indices 1, 3, we have the following writing actions, e.g., for process P_1 the writing action $c_{\mathbf{i}_{\{1,2\}}} x : T$, for process P_2 the writing action $c_{\mathbf{i}_{\{2,3\}}} x : T$ and for process P_3 the writing action $c_{\mathbf{i}_{\{1,3\}}} x : T$. In fact, $c_{\mathbf{i}_{\{1,2\}}} x : T$ is a kind of short hand shown in Listing 1, where P_1 is strongly bisimilar to P_2 .

$$\begin{aligned}
P_1 &= c_{\mathbf{i}_1} x : T \rightarrow \dots \rightarrow \text{SKIP} \\
&\quad \square \\
&\quad c_{\mathbf{i}_2} x : T \rightarrow \dots \rightarrow \text{SKIP} \\
P_2 &= c_{\mathbf{i}_{\{1,2\}}} x : T \rightarrow \dots \rightarrow \text{SKIP}
\end{aligned}$$

Listing 1: Strongly bisimilar processes P_1 and P_2 with respect to indexed writing actions.

Let X_i be the alphabet of process P_i , $i = 1, \dots, 4$. Listing 2 shows the definition of this example, where the enhanced extended half-synchronous parallel operator is denoted as \Downarrow . The *wfnp* action stands for the *waitForNextPeriod* action [7], which is necessary to make sure that the processes in Listing 2 are pairwise consistent.

$$\begin{aligned}
P_1 &= \dots \rightarrow (c_{\mathbf{i}_{\{1,2\}}} x : T \rightarrow \text{wfnp} \rightarrow \text{SKIP} \\
&\quad \square \\
&\quad \text{wfnp} \rightarrow \text{SKIP}) \\
P_2 &= \dots \rightarrow (c_{\mathbf{i}_{\{2,3\}}} x : T \rightarrow \text{wfnp} \rightarrow \text{SKIP} \\
&\quad \square \\
&\quad \text{wfnp} \rightarrow \text{SKIP}) \\
P_3 &= \dots \rightarrow (c_{\mathbf{i}_{\{1,3\}}} x : T \rightarrow \text{wfnp} \rightarrow \text{SKIP} \\
&\quad \square \\
&\quad \text{wfnp} \rightarrow \text{SKIP}) \\
P_4 &= c_i x : T \rightarrow \dots \rightarrow \text{wfnp} \rightarrow \text{SKIP} \\
P_{1,2,3,4} &= ((P_1_{X_1} \Downarrow_{X_2} P_2)_{X_1 \cup X_2} \Downarrow_{X_3} P_3)_{X_1 \cup X_2 \cup X_3} \Downarrow_{X_4} P_4
\end{aligned}$$

Listing 2: The majority vote over a channel c .

Assume that the processes P_1 through P_3 read the following values into x over channel c_1 through c_3 : for c_1 x is v_1 , for c_2 x is v_2 , and for c_3 x is v_2 , respectively. Then, only the processes P_2 and P_3 can engage in the synchronisation over channel c , because they both belong to the group of processes with index 2.

In [1,8,9] we have developed a Vertex-Removing Synchronised Product (VRSP) that improves the performance of PHRCSSs, where the PHRCSS is designed using a

process algebra. With respect to asynchronous writing and reading we have adapted this VRSP into the Dot Vertex-Removing Synchronised Product (DVRSP) in [5] and the Extended Dot Vertex-Removing Synchronised Product (EVRSP) [5]. In this paper we extend the EVRSP into the Enhanced Extended Dot Vertex-Removing Synchronised Product (EEVRSP), while maintaining full flexibility for the asynchronous writing and asynchronous reading.

We start in Section 1 with the terminology used on graphs. In Section 2 we describe the relational semantics of the enhanced extended half-synchronous parallel operator. In Section 3 we give the adaptation of the Extended Vertex Removing Synchronised Product (EVRSP). We finish with the conclusions in Section 4.

1. Terminology

The terminology in this section is a copy of the terminology given in [2] relevant for this paper. We use [10], [11] and [12] for terminology and notations on graphs not defined here.

1.1. Graph Basics

Throughout this paper all graphs we consider are *finite, deterministic, directed, acyclic, labelled multi-graphs*, i.e., they may have multiple arcs. Such graphs consist of a *vertex set* V (representing the states of a process), an *arc set* A (representing the actions, i.e., transitions from one state to another), a set of *labels* L (in our applications in fact a set of label pairs, each representing a type of action and the worst-case duration of its execution), and two mappings. The first mapping $\mu : A \rightarrow V \times V$ is an incidence function that identifies the *tail* and *head* of each arc $a \in A$. In particular, $\mu(a) = (u, v)$ means that the arc a is directed from $u \in V$ to $v \in V$, where $\text{tail}(a) = u$ and $\text{head}(a) = v$. We also call u and v the *ends* of a . The second mapping $\lambda : A \rightarrow L$ assigns a label pair $\lambda(a) = (\ell(a), t(a))$ to each arc $a \in A$, where $\ell(a)$ is a string representing the (name of an) action and $t(a)$ is the *weight* of the arc a . This weight $t(a)$ is a real positive number representing the worst-case execution time of the action represented by $\ell(a)$.

Let G denote a graph according to the above definition. An arc $a \in A(G)$ is called an *in-arc* of $v \in V(G)$ if $\text{head}(a) = v$, and an *out-arc* of v if $\text{tail}(a) = v$. The *in-degree* of v , denoted by $d^-(v)$, is the number of in-arcs of v in G ; the *out-degree* of v , denoted by $d^+(v)$, is the number of out-arcs of v in G . The subset of $V(G)$ consisting of vertices v with $d^-(v) = 0$ is called the *source* of G , and is denoted by $S'(G)$. The subset of $V(G)$ consisting of vertices v with $d^+(v) = 0$ is called the *sink* of G , and is denoted by $S''(G)$.

A graph G is called *weakly connected* if all pairs of distinct vertices u and v of G are connected through a sequence of distinct vertices $u = v_0 v_1 \dots v_k = v$ and arcs $a_1 a_2 \dots a_k$ of G with $\mu(a_i) = (v_{i-1}, v_i)$ or (v_i, v_{i-1}) for $i = 1, 2, \dots, k$. We are mainly interested in weakly connected graphs, or in the weakly connected components of a graph G . If $X \subseteq V(G)$, then the *subgraph of G induced by X* , denoted as $G[X]$, is the graph on vertex set X containing all the arcs of G which have both their ends in X (together with L , μ and λ restricted to this subset of the arcs). If $X \subseteq V(G)$ induces a weakly connected subgraph of G , but there is no set $Y \subseteq V(G)$ such that $G[Y]$ is weakly connected and X is a proper subset of Y , then $G[X]$ is called a *weakly connected component* of G . In the sequel, throughout we omit the words weakly connected, so a component should always be understood as a weakly connected component. In contrast to the notation in the textbook of [10], we use $\omega(G)$ to denote the number of components of a graph G .

We denote the components of G by G_i , where i ranges from 1 to $\omega(G)$. In that case, we use V_i , A_i and L_i as shorthand notation for $V(G_i)$, $A(G_i)$ and $L(G_i)$, respectively. The mappings μ and λ have natural counterparts restricted to the subsets $A_i \subset A(G)$ that we do not specify explicitly. We use $G = \sum_{i=1}^{\omega(G)} G_i$ to indicate that G is the disjoint union of its components, implicitly defining its components as G_1 up to $G_{\omega(G)}$. In particular, $G = G_1$ if and only if G is weakly connected itself.

A graph G is called *deterministic*³ if its arcs have the following property. If $\lambda(a) = \lambda(b)$ for two arcs $a \in A$ and $b \in A$ with $\text{head}(a) \neq \text{head}(b)$, then $\text{tail}(a) \neq \text{tail}(b)$.

An arc a with label pair $\lambda(a)$ in a graph G is a *synchronising arc* with respect to another graph H , if and only if there exists an arc $b \in A(H)$ with label pair $\lambda(b)$ such that $\lambda(a) = \lambda(b)$.

We assume that two different arcs with the same head and tail have different labels; otherwise, we replace such multiple arcs by one arc with that label, because these arcs represent exactly the same action at the same stage of a process. Hence, we require that the following property holds for all the graphs we consider: any two distinct arcs $a \in A$ and $b \in A$ with $\mu(a) = \mu(b)$ have $\lambda(a) \neq \lambda(b)$.

For each pair $(v_i, v_j) \in V(G) \times V(G)$, we let $A(v_i, v_j) = \{a \in A(G) \mid \mu(a) = (v_i, v_j)\}$, and we let $t_m(v_i, v_j) = \max_{a \in A(v_i, v_j)} t(a)$.

A sequence of distinct vertices $v_0 v_1 \dots v_k$ and arcs $a_1 a_2 \dots a_k$ of G is a (directed) path⁴ in G if $\mu(a_i) = (v_{i-1}, v_i)$ for $i = 1, 2, \dots, k$. We denote such a path by $P = v_0 a_1 v_1 a_2 \dots a_k v_k$, and we define its weight as $w(P) = \sum_{a_i \in A(P)} t(a_i)$.

A path from a vertex of the source of G to a vertex of the sink of G is called a *full path* (of G).

The *path length* of G_i , denoted by $\ell(G_i)$, is the maximum of $w(P)$ taken over all full paths P of G_i .

The path length of a graph $G = \sum_{i=1}^{\omega(G)} G_i$, denoted by $\ell(G)$, is defined as $\ell(G) = \sum_{i=1}^{\omega(G)} \ell(G_i)$.

In the next subsection, we introduce a (directed labelled multigraph) analogue of the Cartesian product of two graphs and several other products we derive from it, resulting in the VRSP.

1.2. Graph Products

We start by introducing the next analogue of the Cartesian product.

The *Cartesian product* $G_i \square G_j$ of G_i and G_j is defined as the graph on vertex set $V_{i,j} = V_i \times V_j$, and arc set $A_{i,j}$ consisting of two types of labelled arcs. For each arc $a \in A_i$ with $\mu(a) = (v_i, w_i)$, an *arc of type i* is introduced between tail $(v_i, v_j) \in V_{i,j}$ and head $(w_i, w_j) \in V_{i,j}$ whenever $v_j = w_j$; such an arc receives the label $\lambda(a)$. This implicitly defines parts of the mappings μ and λ for $G_i \square G_j$. Similarly, for each arc $a \in A_j$ with $\mu(a) = (v_j, w_j)$, an *arc of type j* is introduced between tail $(v_i, v_j) \in V_{i,j}$ and head $(w_i, w_j) \in V_{i,j}$ whenever $v_i = w_i$; such an arc receives the label $\lambda(a)$. This completes

³This is equivalent to determinism in the set of processes which is represented by the graph G .

⁴There is a close relationship between a trace and a directed path; ‘a trace is a sequence of visible actions in the order they are observed.’ [3, page 29], a trace $b_1 b_2 \dots b_n$ of a process Q is represented by a path $P = v_0 a_1 v_1 \dots v_{n-1} a_n v_n$ in G , $\ell(a_i) = b_i$, $i = 1, 2, \dots, n$ where the process Q is represented by the graph G .

the definition of $A_{i,j}$ and the mappings μ and λ for $G_i \square G_j$. So, arcs of type i and j correspond to arcs of G_i and G_j , respectively, and have the associated labels. For $k \geq 3$, the Cartesian product $G_1 \square G_2 \square \cdots \square G_k$ is defined recursively as $((G_1 \square G_2) \square \cdots) \square G_k$. This Cartesian product is commutative and associative, as can be verified easily and is a well-known fact for the undirected analogue.

Since we are particularly interested in synchronising arcs, we modify the Cartesian product $G_i \square G_j$ according to the existence of synchronising arcs, i.e., pairs of arcs with the same label pair, with one arc in G_i and one arc in G_j .

The first step in this modification consists of ignoring (in fact deleting) the synchronising arcs while forming arcs in the product, but additionally combining pairs of synchronising arcs of G_i and G_j into one arc, yielding the *intermediate product* which we denote by $G_i \boxtimes G_j$.

To be more precise, $G_i \boxtimes G_j$ is obtained from $G_i \square G_j$ by first ignoring all except for the so-called *asynchronous* arcs, i.e., by only maintaining all arcs $a \in A_{i,j}$ for which $\mu(a) = ((v_i, v_j), (w_i, w_j))$, whenever $v_j = w_j$ and $\lambda(a) \notin L_j$, as well as all arcs $a \in A_{i,j}$ for which $\mu(a) = ((v_i, v_j), (w_i, w_j))$, whenever $v_i = w_i$ and $\lambda(a) \notin L_i$. Additionally, we add arcs that replace synchronising pairs $a_i \in A_i$ and $a_j \in A_j$ with $\lambda(a_i) = \lambda(a_j)$. If $\mu(a_i) = (v_i, w_i)$ and $\mu(a_j) = (v_j, w_j)$, such a pair is replaced by an arc $a_{i,j}$ with $\mu(a_{i,j}) = ((v_i, v_j), (w_i, w_j))$ and $\lambda(a_{i,j}) = \lambda(a_i)$. We call such arcs of $G_i \boxtimes G_j$ *synchronous* arcs.

The second step in this modification consists of removing (from $G_i \boxtimes G_j$) the vertices $(v_i, v_j) \in V_{i,j}$ and the arcs a with $\text{tail}(a) = (v_i, v_j)$, in the case that (v_i, v_j) has *level* > 0 in $G_i \square G_j$ but *level* 0 in $G_i \boxtimes G_j$. This is then repeated in the newly obtained graph, and so on, until there are no more vertices at *level* 0 in the current graph that are at *level* > 0 in $G_i \square G_j$. This finds its motivation in the fact that in our applications, the states that are represented by such vertices can never be reached, so are irrelevant.

The resulting graph is called the *Vertex-Removing Synchronised Product* (VRSP for short) of G_i and G_j , and denoted as $G_i \boxtimes G_j$. For $k \geq 3$, the VRSP $G_1 \boxtimes G_2 \boxtimes \cdots \boxtimes G_k$ is defined recursively as $((G_1 \boxtimes G_2) \boxtimes \cdots) \boxtimes G_k$. The VRSP is commutative, but not associative in general, in contrast to the Cartesian product. However, associativity of the VRSP is guaranteed if we require the graphs on which we apply the VRSP to be pairwise consistent.

Recall that our processes are acyclic, but are started again at every period of the PHRCS. Therefore, whenever two processes P_1 and P_2 are consistent, this means that in their parallel execution both processes will reach their set of final states. For the two components G_1 and G_2 representing these two processes, this means that the sinks of G_1 and G_2 must represent the final states of P_1 and P_2 . But for $G_1 \boxtimes G_2$ this only makes sense if the sink of $V(G_1 \boxtimes G_2)$ represents the final states of the process $P_{1,2}$ (where $P_{1,2}$ is strongly bisimilar to $P_1 || P_2$). We will introduce several contraction concepts in graphs to describe and analyse consistency of the associated processes. This is explained and formalised by the concepts of a weak contraction, a strong contraction and a pseudopath in Section 1.3.

1.3. Graph Isomorphism and Graph Contraction

The isomorphism we introduce in this section is an analogue of a known concept for unlabelled graphs, but involves statements on the labels.

Formally, an *isomorphism* from G to H consists of two bijections $\phi : V(G) \rightarrow V(H)$ and $\psi : A(G) \rightarrow A(H)$ such that for all $a \in A(G)$ $\mu(a) = (u, v)$ if and only if $\mu(\psi(a)) = (\phi(u), \phi(v))$ and $\lambda(a) = \lambda(\psi(a))$. Since we assume that two different arcs with the same head and tail have different labels, however, the bijection ψ is superfluous. The reason is

that, if (ϕ, ψ) is an isomorphism, then ψ is completely determined by ϕ and the labels. In fact, if (ϕ, ψ) is an isomorphism and $\mu(a) = (u, v)$ for an arc $a \in A(G)$, then $\psi(a)$ is the unique arc $b \in A(H)$ with $\mu(b) = (\phi(u), \phi(v))$ and label $\lambda(b) = \lambda(a)$. Thus, we may define an isomorphism from G to H as a bijection $\phi : V(G) \rightarrow V(H)$ such that there exists an arc $a \in A(G)$ with $\mu(a) = (u, v)$ if and only if there exists an arc $b \in A(H)$ with $\mu(b) = (\phi(u), \phi(v))$ and $\lambda(b) = \lambda(a)$.

We distinguish two types of contractions. The first type contracts vertices in $G_1 \boxtimes G_2$ related to asynchronous arcs of graphs G_1 and G_2 and is called a *weak contraction*. The second type contracts a set of vertices without taking into account whether the arcs belonging to these vertices are synchronous or asynchronous and is called a *strong contraction*.

Let $a \in A(G)$ with $\mu(a) = (u, v)$. By contracting a we mean replacing u and v by a new vertex $\bar{u}\bar{v}$, deleting all arcs $b \in A(G)$ with $\mu(b) = (u, v)$ or $\mu(b) = (v, u)$, and for any $x \neq u, v$ replacing each pair of arcs $c \in A(G)$ and $d \in A(G)$ with $\mu(c) = (u, x)$, $\mu(d) = (v, x)$ and $\lambda(c) = \lambda(d)$ by one arc e with $\mu(e) = (\bar{u}\bar{v}, x)$ and $\lambda(e) = \lambda(c)$, and, similarly replacing each pair of arcs $c \in A(G)$ and $d \in A(G)$ with $\mu(c) = (x, u)$, $\mu(d) = (x, v)$ and $\lambda(c) = \lambda(d)$ by one arc e with $\mu(e) = (x, \bar{u}\bar{v})$ and $\lambda(e) = \lambda(c)$.

To define the notion of weak contraction, let T be the set of asynchronous arcs in $G_1 \boxtimes G_2$ that correspond to arcs in G_1 . Then the *weak contraction of $G_1 \boxtimes G_2$ with respect to G_1* , denoted by $\rho_{G_1}(G_1 \boxtimes G_2)$, is defined as the graph obtained from $G_1 \boxtimes G_2$ by successively contracting each arc $a \in T$. Likewise, let T be the set of asynchronous arcs in $G_1 \boxtimes G_2$ that correspond to arcs in G_2 . Then the *weak contraction of $G_1 \boxtimes G_2$ with respect to G_2* , denoted by $\rho_{G_2}(G_1 \boxtimes G_2)$, is defined as the graph obtained from $G_1 \boxtimes G_2$ by successively contracting each arc $a \in T$. We also use G_1^ρ as shorthand for $\rho_{G_2}(G_1 \boxtimes G_2)$ and G_2^ρ as shorthand for $\rho_{G_1}(G_1 \boxtimes G_2)$.

Let H be a subgraph of $G_1 \boxtimes G_2$. Then in $\rho_{G_2}(G_1 \boxtimes G_2)$, H corresponds to a subgraph H' of G_1 . We denote this H' by $\rho_{G_2}(H)$, and say that H is mapped to $\rho_{G_2}(H)$ by ρ_{G_2} . We use similar terminology and notation with respect to for $\rho_{G_1}(H)$.

We now turn to the definition of strong contraction. Let X be a nonempty proper subset of $V(G)$, and let $Y = V(G) \setminus X$. Then to obtain the strong contraction of G with respect to X , we first replace X by a new vertex \tilde{x} , deleting all arcs with both ends in X , delete all arcs $a \in A(G)$ with $\mu(a) = (u, v)$ for $u \in X$ and $v \in Y$ by an arc c with $\mu(c) = (\tilde{x}, v)$ and $\lambda(c) = \lambda(a)$, and replace each arc $b \in A(G)$ with $\mu(b) = (u, v)$ for $u \in Y$, and replace $v \in X$ by an arc d with $\mu(d) = (u, \tilde{x})$ and $\lambda(d) = \lambda(b)$. If after this contraction there are arcs with the same ends and labels, then these arcs are replaced by one arc with the same ends and label. We denote the resulting graph as G/X , and say that G/X is the *strong contraction of G with respect to X* .

We use the strong contraction in particular to remove non-determinism, in the following way. Recall that non-determinism occurs in a graph G if there is a set of arcs $B \in A(G)$ with the same tail and label, but different heads. In this case, let us denote such a set of different heads by Z . In G/Z , all the arcs of B (with heads in Z) are replaced by one arc with the same tail and label and a new head. So, this removes the non-determinism from G caused by the arc set B . If there occurs non-determinism in the graph G/Z , we iteratively repeat the above contraction procedure until the resulting graph is deterministic. We denote the resulting graph by G^δ .

Let H be a subgraph of G . Then in G^δ , the graph that corresponds to H is denoted by H^δ . We say that H is mapped to H^δ by δ .

The above two types of contractions play a key role in our notion of consistency of graphs. Before we define this notion, we first introduce one additional concept. This concept relates paths in $G_1 \boxtimes G_2$ to paths in $(G_1^\rho)^\delta$ and $(G_2^\rho)^\delta$, in the following way.

A full path P of $G_1 \boxtimes G_2$ is called a *pseudopath* if $\rho_{G_2}(P)$ is isomorphic to a full path

in G_1 , and $\rho_{G_1}(P)$ is isomorphic to a full path in G_2 . Note that in this case $(\rho_{G_2}(P))^\delta$ is a unique full path in $(G_1^\rho)^\delta$, and $(\rho_{G_1}(P))^\delta$ is a unique full path in $(G_2^\rho)^\delta$, that satisfy this condition. In particular, P is a full path in $(\rho_{G_2}(P))^\delta \boxtimes (\rho_{G_1}(P))^\delta$. We often say there exists a full path in G_1 (G_2) for a pseudopath in $G_1 \boxtimes G_2$ if we mean that these paths exist in the above sense when $(G_1^\rho)^\delta \cong G_1$ (and $(G_2^\rho)^\delta \cong G_2$). Similarly, we often say there exists a pseudopath in $G_1 \boxtimes G_2$ for every full path in G_1 (G_2) if we mean that there exists a pseudopath P in $Q \boxtimes R$ for full paths Q in G_1 and R in G_2 .

2. The Relational Semantics of the Enhanced Extended Half-Synchronous Parallel Operator

If processes write synchronously to a channel this synchronous writing is inhibited by the early versions of CSP⁵. Later on this was relaxed to multiple writers to the same channel [13]. In [5] we described asynchronous writing and reading in such a manner that the writers will deadlock if they are trying to invoke the same writing action. We lift these restrictions such that the writers are allowed to write synchronously as well as asynchronously, and the readers are allowed to read synchronously as well as asynchronously. Apart from the synchronous and asynchronous writing, this has been described in [6]. In this section, we complete the description of asynchronous writing and asynchronous reading by two extensions of the Half-Synchronous Operator:

- Indexing of the $\mathfrak{!}$ -action, allowing set-wise asynchronous reading and intra-set-wise synchronous reading.
- Indexing of the $\mathfrak{?}$ -action, allowing set-wise asynchronous writing and intra-set-wise synchronous writing.

The relational semantics of the *enhanced extended half-synchronous alphabetised parallel operator* $(\mathfrak{!}_X \Downarrow_Y)$ is given in Figure 1. But first, we give an example of asynchronous writing and asynchronous reading describing a *majority vote*. Assume we are considering a safety-critical system controlling one actuator via three sensors. Each sensor is read from by a different process and the actuator is written to by a different process. The value read from the sensor is mapped into three ranges, say high, middle and low. The values are only *invalid* if one process maps its value into the high range, one process maps its value into the middle range, and the remaining process maps its value into the low range. In this case an error has to be raised, which is beyond the scope of this example. All other combinations lead to a valid value and the value which has a majority is sent to the actuator. To achieve consistent processes and thereby avoid a deadlock, we use a *waitForNextPeriod*-action (the *wfnp* in the model) to align with the period of the PHRCS. This requirement is easily modelled by synchronising actions representing the high, middle and low ranges.

As an example, if in Listing 3 sensor S_0 has read the value 74, sensor S_1 has read the value 75, and sensor S_2 has read the value 76, the value *middle* will be chosen and sent to the actuator. To avoid that all processes engage at the start in a *wfnp* action, a clock process C with alphabet Z has been added that enables the *wfnp* action after the timer has expired. The *wfnp* action is enabled just before the end of the period. The time-out value must be chosen in such a manner that after expiration there is only just enough time (in the order of a few μs) for a read and write communication to finish execution, e.g., if the communication and actions of the sensors and the actuator takes

⁵Because we consider acyclic processes and therefore acyclic graphs only, our extension of CSP is in fact more a domain-specific CSP dialect.

$$\begin{aligned}
S_i &= \text{read}.x_i \rightarrow \{x_i < 75 \& c_{\{i,(i+1)\%3\}} \text{low} \rightarrow \text{wfnp} \rightarrow \text{SKIP} \\
&\quad \square \\
&\quad 75 \leq x_i < 125 \& c_{\{i,(i+1)\%3\}} \text{middle} \rightarrow \text{wfnp} \rightarrow \text{SKIP} \\
&\quad \square \\
&\quad 125 \leq x \& c_{\{i,(i+1)\%3\}} \text{high} \rightarrow \text{wfnp} \rightarrow \text{SKIP} \\
&\quad \square \\
&\quad \text{wfnp} \rightarrow \text{SKIP} \} \\
&\quad \square \\
&\quad \text{wfnp} \rightarrow \text{SKIP}
\end{aligned}$$

$$\begin{aligned}
A &= c_{\text{low}} \rightarrow \text{writeActuator}(\text{low}) \rightarrow \text{wfnp} \rightarrow \text{SKIP} \\
&\quad \square \\
&\quad c_{\text{middle}} \rightarrow \text{writeActuator}(\text{middle}) \rightarrow \text{wfnp} \rightarrow \text{SKIP} \\
&\quad \square \\
&\quad c_{\text{high}} \rightarrow \text{writeActuator}(\text{high}) \rightarrow \text{wfnp} \rightarrow \text{SKIP} \\
&\quad \square \\
&\quad \text{wfnp} \rightarrow \text{SKIP}
\end{aligned}$$

$$C = \text{timeout} \rightarrow \text{wfnp} \rightarrow \text{SKIP}$$

$$\text{SafetyCriticalSystem} = (A_X \Downarrow_{Y_0 \cup Y_1 \cup Y_2} ((S_0_{Y_1} \Downarrow_{Y_2} S_1)_{Y_0 \cup Y_1} \Downarrow_{Y_2} S_2))_{X \cup Y_0 \cup Y_1 \cup Y_2} \Downarrow_Z C$$

Listing 3: Indexed reading from and writing to a buffer.

in total 100 μs and the period is 1 ms then the time-out should expire at less than 900 μs .

We continue with the definition of the relational semantics of the enhanced extended half-synchronous operator \Downarrow . Let I_i be a non-empty subset of the set $I = \{1, 2, \dots, m\}$. Let J_j be a non-empty subset of the set $J = \{1, 2, \dots, n\}$. Let $P = \{P_1, \dots, P_m\}$ be the set of processes containing an indexed asynchronous i_{I_i} - action. Let $Q = \{Q_1, \dots, Q_n\}$ be the set of processes containing an indexed asynchronous j_{J_j} - action. Then, in Figure 1 we give

- the semantics of the enhanced extended half-synchronous operator,
- if we need more than one process P we use P_i otherwise we use P ,
- the alphabets of $P, P_1, \dots, P_m, Q_1, \dots, Q_n$ are denoted as $X, X_1 \dots, X_m, Y_1 \dots, Y_n$, respectively, and
- for ease of reading, we omit the alphabets for the extended half-synchronous operator, therefore $P_i \downarrow_{X_i} P_j$ is denoted as $P_i \Downarrow P_j$ (likewise for Q_i and Q_j).

The rules R_1 through R_7 are given in Figure 1, where

R_1 specifies that two indexed writing actions with different index sets are asynchronous.

R_2 specifies that for two or more writing actions to the same channel by two or more processes are synchronous⁶ if the labels of the writing actions have an index in common and are identical as far as the labels without the index sets are concerned, as, for example, in Listing 2.

⁶This is similar to a voting design pattern, where a majority of voters is necessary to reach a decision.

$$\begin{aligned}
R_1 : & \frac{P_1 \xrightarrow{c_{\mathbf{i}_{I_1}} x:T} P'_1, P_2 \xrightarrow{c_{\mathbf{i}_{I_2}} x:T} P'_2}{(P_1 \Downarrow P_2) \rightarrow (P'_1 \Downarrow P_2) \oplus (P_1 \Downarrow P'_2)}, I_1 \cap I_2 = \emptyset, \\
R_2 : & \frac{P_1 \xrightarrow{c_{\mathbf{i}_{I_1}} x:T} P'_1, P_2 \xrightarrow{c_{\mathbf{i}_{I_2}} x:T} P'_2, \dots, P_k \xrightarrow{c_{\mathbf{i}_{I_k}} x:T} P'_k}{(P_1 \Downarrow P_2 \Downarrow \dots \Downarrow P_k) \rightarrow (P'_1 \Downarrow P'_2 \Downarrow \dots \Downarrow P'_k)}, I = I_1 \cap I_2 \cap \dots \cap I_k \neq \emptyset, \\
& c_{\mathbf{i}_{I_n}} x : T \in X_n, n \notin \{1, \dots, k\} \Rightarrow I \cap I_n = \emptyset \\
R_3 : & \frac{P_i \xrightarrow{c_{\mathbf{i}_{I_i}} x:T} P'_i, P_1 \xrightarrow{y} P'_1, P_2 \xrightarrow{y} P'_2, \dots, P_k \xrightarrow{y} P'_k}{P_i \Downarrow P_1 \Downarrow P_2 \Downarrow \dots \Downarrow P_k \xrightarrow{y} P_i \Downarrow P'_1 \Downarrow P'_2 \Downarrow \dots \Downarrow P'_k}, i \notin \{1, \dots, k\}, y \notin X_i, \\
& c_{\mathbf{i}_{I_j}} x : T \in X_j, j \in \{1, \dots, k\}, I_i \subseteq I_1 \cup \dots \cup I_k, \mathbf{i} \text{ not in } y \\
R_4 : & \frac{P_k \xrightarrow{c_{\mathbf{i}_{I_k}} x:T} P'_k, Q_i \xrightarrow{c_{\mathbf{i}_{I_i}} x:T} Q'_i, Q_j \xrightarrow{c_{\mathbf{i}_{I_j}} x:T} Q'_j}{(P_k \Downarrow Q_i \Downarrow Q_j) \xrightarrow{c_{\mathbf{i}_{I_k}} x:T} (P'_k \Downarrow Q_i \Downarrow Q_j) \rightarrow ((P'_k \Downarrow Q'_i \Downarrow Q_j) \oplus (P'_k \Downarrow Q_i \Downarrow Q'_j)) \rightarrow (P'_k \Downarrow Q'_i \Downarrow Q'_j)}, \\
& i \neq j \\
R_5 : & \frac{P \xrightarrow{c_{\mathbf{i}_{I_j}} x:T} P', Q_1 \xrightarrow{c_{\mathbf{i}_{I_1}} x:T} Q'_1, \dots, Q_k \xrightarrow{c_{\mathbf{i}_{I_k}} x:T} Q'_k}{P \Downarrow Q_1 \Downarrow \dots \Downarrow Q_k \xrightarrow{c_{\mathbf{i}_{I_j}} x:T} P' \Downarrow Q_1 \Downarrow \dots \Downarrow Q_k \rightarrow P' \Downarrow Q'_1 \Downarrow \dots \Downarrow Q'_k}, \\
& c_{\mathbf{i}_i} x : T \notin X_n, n \notin \{1, \dots, k\} \\
R_6 : & \frac{P \rightsquigarrow P', Q_j \xrightarrow{c_{\mathbf{i}_{I_j}} x:T} Q'_j}{P \Downarrow Q_j \rightsquigarrow P' \Downarrow Q'_j}, c_{\mathbf{i}_{I_i}} x : T \notin \alpha(\rightsquigarrow), (\alpha(\rightsquigarrow) \cdot (Y_1, \dots, Y_n, Z)) = \emptyset, \\
R_7 : & \frac{Q_i \xrightarrow{c_{\mathbf{i}_{I_i}} x:T} Q'_i, Q_j \xrightarrow{y} Q'_j}{Q_i \Downarrow Q_j \rightarrow Q_i \Downarrow Q'_j}, y \neq c_{\mathbf{i}_i} x : T, c_{\mathbf{i}_i} x : T \in Y_j\}
\end{aligned}$$

Figure 1. Relational semantics of the enhanced extended half-synchronous operator for a specification comprising the processes $P_1, \dots, P_m, Q_1, \dots, Q_n$.

R_3 specifies that a writing action with index i in its index set cannot be performed if one or more processes that contain this writing action with index i in their index set are not in a state where this writing action can be performed.

R_4 specifies that an indexed reading action must always be preceded by a related⁷ writing action and the reading actions with different indexes are asynchronous.

R_5 specifies that a set of indexed reading actions with the same index must be preceded by a related writing action and that these reading actions are synchronous.

R_6 specifies that indexed reading actions must be preceded by a related writing action.

R_7 specifies that indexed reading actions with the same index are synchronous.

⁷Based on [6], two actions are related if and only if

- *one* action contains the \mathbf{i}_{I_i} precisely once and does not contain the \mathbf{i}_n , and the *other* action contains the \mathbf{i}_n precisely once and does not contain the \mathbf{i}_{I_i} ,
- the prefix of the labels of *both* actions with respect to the \mathbf{i}_{I_i} and \mathbf{i}_n is identical and
- the postfix of the labels of *both* actions with respect to the \mathbf{i}_{I_i} and \mathbf{i}_n is identical.

Remark 1. Clearly, both the \mathbf{i}_{I_i} -action and the \mathbf{i}_{I_i} -action are prone to deadlocks. As an example, if one process contains $\mathbf{c}_{\mathbf{i}_{\{1,2\}}}x : T$ followed by $\mathbf{c}_{\mathbf{i}_{\{3,4\}}}x : T$ and another process contains the same actions in reversed order the two processes may deadlock. Because we consider processes represented by consistent graphs only, such a process definition is inhibited.

In the next section we discuss the impact of these relational semantics on the VRSP.

3. The VRSP of the Enhanced Extended Half-Synchronous Alphabetised Parallel Operator

As we are taking into account pairs of consistent graphs only, $\mathbf{c}_{\mathbf{i}_n}x : T$ in one process without a related $\mathbf{c}_{\mathbf{i}_n}x : T$ in any other process is inhibited, because the process may end in a deadlock and the deadlock violates the consistency requirements. Also, the processes containing indexed writing actions must be pairwise consistent and the processes containing indexed reading actions must be pairwise consistent. The definition of consistency for the EEVRSP is given in Definition 1. The EEVRSP is defined on page 12 just below Definition 1.

We start with a simple example showing a majority vote specified in Listing 2. This example is smaller than the example given in Listing 3, because otherwise the figure would become unreadable. In Figure 2, we give the graphs G_1 and G_2 representing the specification of the writing processes P_1 and P_2 , and the EEVRSP of G_1 and G_2 , $G_{1,2} = G_1 \overset{\circ}{\boxtimes} G_2$, leaving out the not relevant actions (the dots, \dots) of these processes.

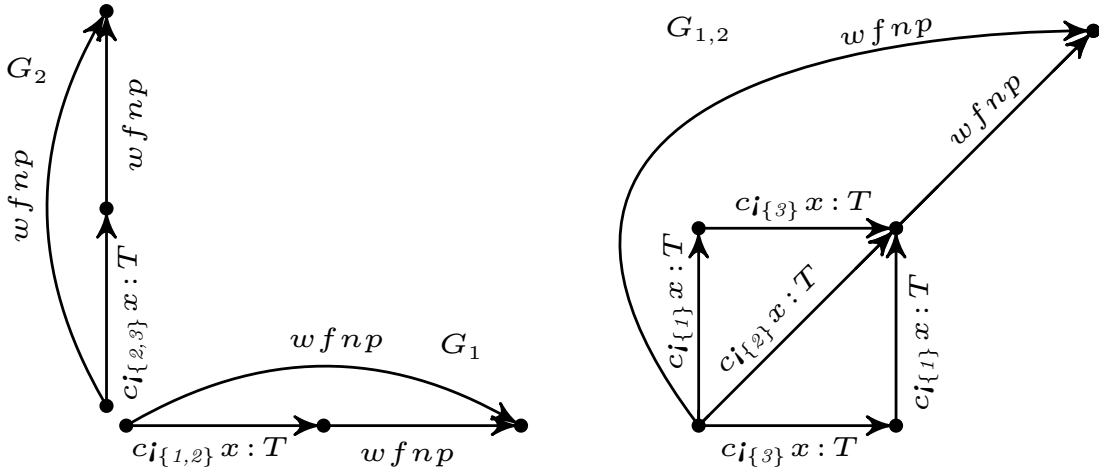

Figure 2. Graphs G_1, G_2 , and $G_{1,2} = \overset{\circ}{\boxtimes}_{i=1}^2 G_i$ representing processes P_1 and P_2 , and their parallel composition ($P_{1 \times_1} \uparrow_{\times_2} P_2$) of Listing 2.

In Figure 3, we give the graphs G_1, G_2 and G_3 , and the EEVRSP of G_1, G_2 and G_3 , $G_{1,2,3} = \overset{\circ}{\boxtimes}_{i=1}^3 G_i$ representing the specification of the writing processes P_1, P_2 and P_3 . The EEVRSP of these graphs shows clearly that whenever an indexed writing action has a majority, it will be selected for execution, leading to a transition to the next state. The $wfnp$ -action makes sure that all processes involved in this subsystem are pairwise consistent.

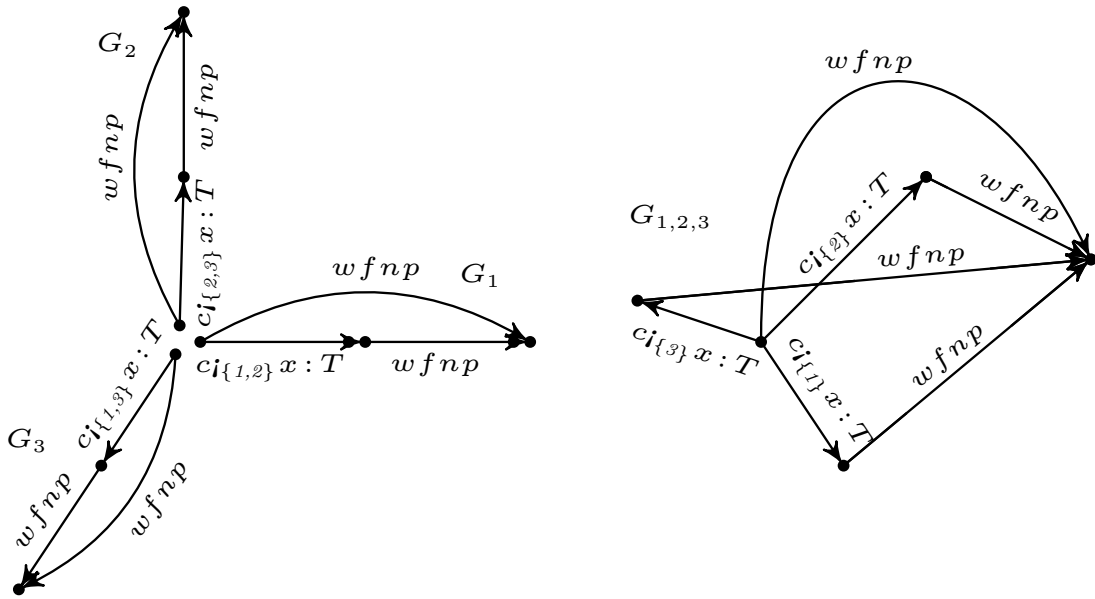

Figure 3. Graphs G_1, G_2, G_3 , and $G_{1,2,3} = \bigboxtimes_{i=1}^3 G_i$ representing processes P_1, P_2, P_3 , and their parallel composition $(P_{1_{x_1}} \uparrow_{x_2} P_2)_{x_1 \cup x_2} \uparrow_{x_3} P_3$ of Listing 2.

In Figure 4, we give the graphs representing the interaction of the graph $G_{1,2,3}$ representing the parallel execution of the three writing processes P_1, P_2 and P_3 , and the reading process P_4 of Listing 2.

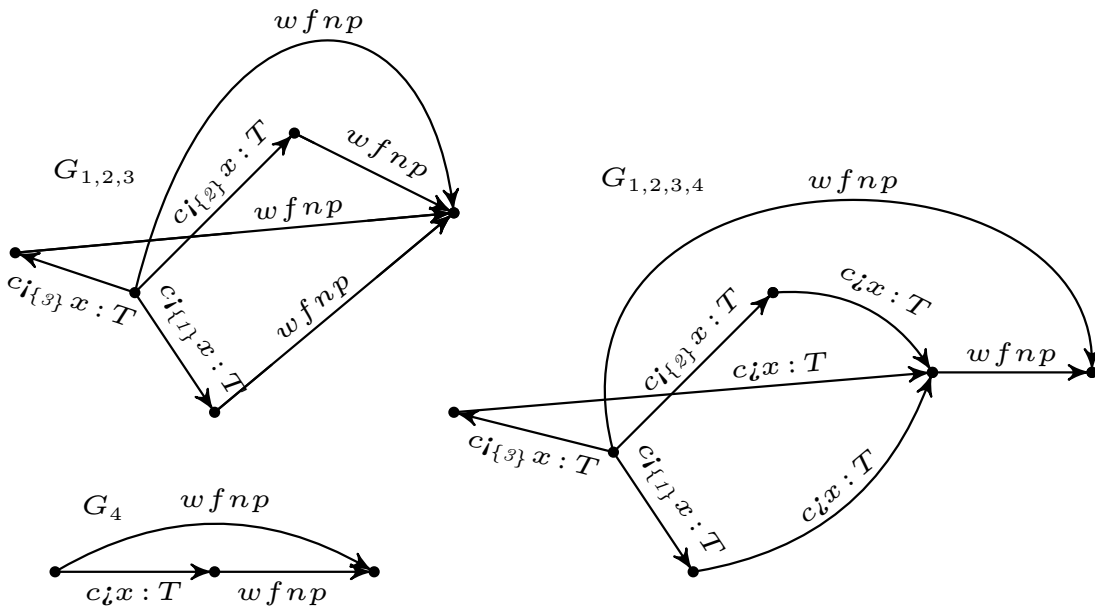

Figure 4. Graphs $G_{1,2,3}, G_4$, and $G_{1,2,3,4} = \bigboxtimes_{i=1}^4 G_i$ representing processes $(P_{1_{x_1}} \uparrow_{x_2} P_2)_{x_1 \cup x_2} \uparrow_{x_3} P_3, P_4$, and their parallel composition $((P_{1_{x_1}} \uparrow_{x_2} P_2)_{x_1 \cup x_2} \uparrow_{x_3} P_3)_{x_1 \cup x_2 \cup x_3} \uparrow_{x_4} P_4$ of Listing 2.

Remark 2. The EEVRSP of the graphs G_1, \dots, G_4 , $G_{1,2,3,4} = \overset{\circ}{\boxtimes}_{i=1}^4 G_i$ gives a performance gain because the length of the graph $\sum_{i=1}^4 G_i$ equals eight, whereas the length of the graph $G_{1,2,3,4}$ equals three.

We have defined the notion of consistency of graphs under EVRSP in [6] and adjust it here to consistency of graphs under the EEVRSP. Because we introduce the notion of an indexed writing action in this paper, we give the following definition for this indexed writing action. An indexed writing action $c_{\mathbf{i}_{I_i}} x : T$ is represented by the set of arcs a with $\mu(a) = (u, v)$ and $\lambda(a) = \{c_{\mathbf{i}_{\{i\}}} x : T \mid i \in I_i\}$. Furthermore, we adapt the definition of the path read and path write cardinality defined in [6] such that it meets the requirements for the EEVRSP.

The number of occurrences of an indexed write action $c_{\mathbf{i}_{I_i}} x : T$ in the path P with respect to an index $k \in I_i$, is called the *path write cardinality* of a path with respect to $c_{\mathbf{i}_{I_i}} x : T$ for the index k , denoted as $P(c_{\mathbf{i}_{k \in I_i}} x : T)$.

The number of occurrences of an indexed read action $c_{\mathbf{i}_n} x : T$ in the path P , is called the *path read cardinality* of a path with respect to $c_{\mathbf{i}_n} x : T$, denoted as $P(c_{\mathbf{i}_n} x : T)$.

Definition 1. Components G_i and G_j are consistent if and only if the following three requirements apply:

1. $\rho_{G_i}(G_i \overset{\circ}{\boxtimes} G_j)^\delta \cong G_j$ and $\rho_{G_j}(G_i \overset{\circ}{\boxtimes} G_j)^\delta \cong G_i$.
2. $S'(G_i \overset{\circ}{\boxtimes} G_j) = S'(G_i) \times S'(G_j)$ and $S''(G_i \overset{\circ}{\boxtimes} G_j) = S''(G_i) \times S''(G_j)$.
3. Whenever Q and R are paths from the source to the sink of G_i ($G_j, G_i \overset{\circ}{\boxtimes} G_j$), $Q(c_{\mathbf{i}_{k \in I_i}} x : T) = R(c_{\mathbf{i}_{k \in I_j}} x : T)$ for all $k \in I_i \cup I_j$ and $Q(c_{\mathbf{i}_k} x : T) = R(c_{\mathbf{i}_k} x : T)$.

The EEVRSP of G_i and G_j , $G_i \overset{\circ}{\boxtimes} G_j$ is closely related to the VRSP and EVRSP of G_i and G_j , and is constructed in two stages, where the definition of the intermediate stage of DVRSP is identical to the intermediate stage of EEVRSP, $G_i \overset{\circ}{\boxtimes} G_j = G_i \overset{\circ}{\boxtimes} G_j$, with

- $v_x w_x \in A_{i,j}$ is an arc with operator \mathbf{i}_n in $l(v_x w_x) = l_r$,
- P_n is a path from the source of $G_i \overset{\circ}{\boxtimes} G_j$ through w_x ,
- P_m is the path from the source to the sink of $G_i \overset{\circ}{\boxtimes} G_j$.

As in [6], we modify the Cartesian product $G_i \square G_j$ according to the existence of synchronising arcs, but now with the extra constraint that indexed writing actions containing an index $k \in I_i, I_j$ are synchronous and indexed writing actions containing an index $k \in I_i$ and $k \notin I_j$ ($k \notin I_i$ and $k \in I_j$) are asynchronous.

The first step in this modification consists of ignoring the synchronising arcs while forming arcs in the product, but additionally combining pairs of synchronising arcs of G_i and G_j into one arc, yielding the intermediate product which we denote by $G_i \overset{\circ}{\boxtimes} G_j$. To be more precise, $G_i \overset{\circ}{\boxtimes} G_j$ is obtained from $G_i \square G_j$ by first ignoring all except for the so-called asynchronous arcs, i.e., by only maintaining all arcs $a \in A_{i,j}$ for which $\mu(a) = ((v_i, v_j), (w_i, w_j))$, whenever $v_j = w_j$ and $\lambda(a) \notin L_j$, as well as all arcs $a \in A_{i,j}$ for which $\mu(a) = ((v_i, v_j), (w_i, w_j))$, whenever $v_i = w_i$ and $\lambda(a) \notin L_i$. This set of arcs

is denoted by $A_{i,j}^a$. Additionally, we add arcs that replace synchronising pairs $a_i \in A_i$ and $a_j \in A_j$ with $\lambda(a_i) = \lambda(a_j)$. If $\mu(a_i) = (v_i, w_i)$ and $\mu(a_j) = (v_j, w_j)$, such a pair is replaced by an arc $a_{i,j}$ with $\mu(a_{i,j}) = ((v_i, v_j), (w_i, w_j))$ and $\lambda(a_{i,j}) = \lambda(a_i)$. The set of these so-called synchronous arcs of $G_i \boxtimes G_j$ is denoted by $A_{i,j}^s$.

The second step in this modification consists of removing (from $G_i \boxtimes G_j$) the vertices $(v_i, v_j) \in V_{i,j}$ and the arcs a with $\text{tail}(a) = (v_i, v_j)$, whenever (v_i, v_j) has $\text{level} > 0$ in $G_i \square G_j$ and (v_i, v_j) has $\text{level} 0$ in $G_i \boxtimes G_j$ and all arcs $v_x w_x \in A_{i,j}$ for which there exists a related arc $v_y w_y \in A_{i,j}$, with operator \mathbf{i}_n in $l(v_x w_x)$ for which there does not exist at least n related arcs $v_y w_y$ with operator \mathbf{i}_i in $l(v_y w_y)$ with $v_y w_y < v_x w_x$. This is then repeated in the newly obtained graph, and so on, until there are no more vertices at $\text{level} 0$ in the current graph that are at $\text{level} > 0$ in $G_i \square G_j$.

The resulting graph is called the EEVRSP of G_i and G_j , denoted as $G_i \boxdot G_j$.

For $k \geq 3$, the EEVRSP $G_1 \boxdot G_2 \boxdot \dots \boxdot G_k$ is defined recursively as $((G_1 \boxdot G_2) \boxdot \dots) \boxdot G_k$.

Remark 3. Because arcs $v_i w_i$ with $\mathbf{i} \in l(v_i w_i)$ are indexed, the arcs $v_i w_i$ with different indexes represent asynchronous actions, because they have different labels due to different indexes.

In Figure 5 we show an example based on an example from [6] that shows the stages of the EEVRSP with respect to the delayed reading actions. Figure 5.a shows

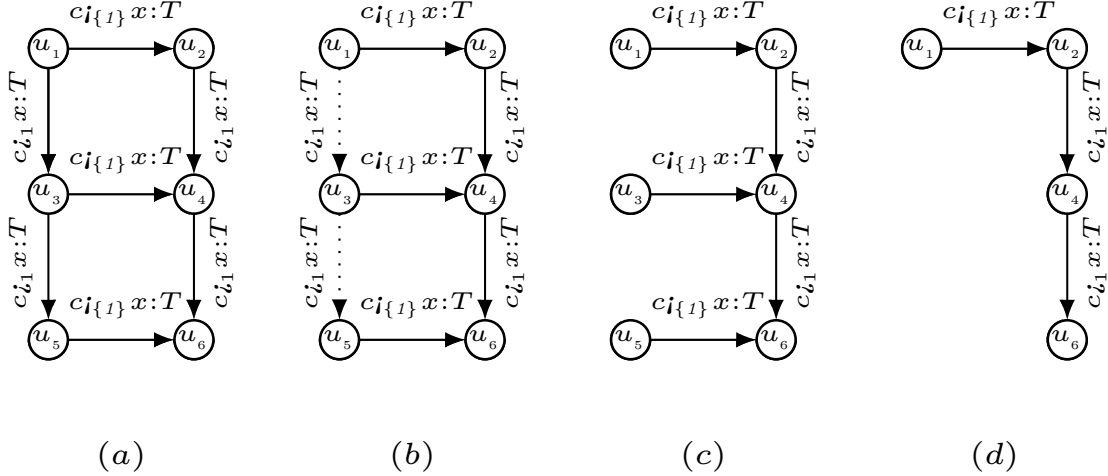

Figure 5. EVRSP from $G_1 \square G_3$ (a), two stages of $G_1 \boxtimes G_3$ (b,c), to $G_1 \boxdot G_3$ (d).

the Cartesian Product of graphs G_1 and G_2 , where G_1 represents only one indexed writing action and G_2 represents a series of two indexed reading actions. Obviously, the index set of the writing action may contain more than one element. The dotted arcs in Figure 5.b are selected for removal. After removing the dotted arcs we have Figure 5.c. In Figure 5.c the vertices u_3 and u_5 and their arcs are removed because in the Cartesian Product (Figure 5.a) they have an in-degree greater than zero, whereas in Figure 5.c the vertices u_3 and u_5 have an in-degree of zero. After removal of the vertices u_3 and u_5 and their arcs in Figure 5.c we get Figure 5.d.

4. Discussion and Conclusions

In this paper we have discussed the new $X \Downarrow Y$ operator, the new i_{I_i} -action and the i_n -action, which enables the possibility to model a majority vote in an easy and straightforward manner. The $X \Downarrow Y$ operator together with the i_{I_i} -action replaces a series of choices, reducing the size of the specification and making the design less error prone. As for the EEVRSP, the writing processes do not have to wait for the reading processes to synchronise and the designer has the choice to have synchronous as well as asynchronous writes to a channel. Furthermore, the overall design cycle will gain because the improved description on design level will lead to less effort for the implementation and less effort for testing. To summarise these advantages we have:

1. it eases the design in case the application needs both synchronous as well as asynchronous writes to a channel,
2. it gives maximum flexibility by indexing the writing *and* reading actions,
3. it allows multiple write actions, both synchronous as well as asynchronous to the same channel,
4. the advantages of the VRSP and EVRSP are preserved.

The first, second and third advantage makes the design less error-prone and therefore the design phase needs less time. The fourth advantage leads to an application for which the end-to-end execution time of the application is reduced and due to the reduction of the number of context switches, the overall utilisation of the processor is reduced.

Acknowledgement

The authors would like to express their gratitude to the anonymous reviewers for the very useful suggestions and comments.

The research of the first author has been funded by the InHolland University of Applied Science, Alkmaar, The Netherlands.

References

- [1] A. H. Boode and J. F. Broenink. Performance of periodic real-time processes: a vertex-removing synchronised graph product. In *Communicating Process Architectures 2014, Oxford, UK*, 36th WoTUG conference on concurrent and parallel programming, pages 119–138, Bicester, August 2014. Open Channel Publishing Ltd.
- [2] A. H. Boode. *On the Automation of Periodic Hard Real-Time Processes, A Graph-Theoretical Approach*. PhD thesis, University of Twente, June 2018.
- [3] A. W. Roscoe. *Understanding Concurrent Systems*. Springer, 2010.
- [4] C. A. R. Hoare. Communicating sequential processes. *Commun. ACM*, 21:666–677, aug 1978.
- [5] A. H. Boode and J. F. Broenink. Asynchronous readers and writers. In *Communicating Process Architectures 2016, Copenhagen, Denmark*, 38th WoTUG conference on concurrent and parallel programming, pages 125–137, Bicester, August 2016. Open Channel Publishing Ltd.
- [6] A. H. Boode and J. F. Broenink. Asynchronous readers and asynchronous writers. In *Communicating Process Architectures 2017, Valetta, Malta*, 39th WoTUG conference on concurrent and parallel programming, pages 125–137, Bicester, August 2017. Open Channel Publishing Ltd.
- [7] Gregory Bollella. *The Real-time Specification for Java*. Addison-Wesley Java Series. Addison-Wesley, 2000.
- [8] A. H. Boode, H. J. Broersma, and J. F. Broenink. Improving the performance of periodic real-time processes: a graph-theoretical approach. In *Communicating Process Architectures 2013, Edinburgh, UK*, 35th WoTUG conference on concurrent and parallel programming, pages 57–79, Bicester, August 2013. Open Channel Publishing Ltd.

- [9] A. H. Boode, H. J. Broersma, and J. F. Broenink. On a directed tree problem motivated by a newly introduced graph product. *GTA Research Group, Univ. Newcastle, Indonesian Combinatorics Society and ITB*, 3, no 2 (2015): Electronic Journal of Graph Theory and Applications, 2015.
- [10] J.A. Bondy and U.S.R. Murty. *Graph Theory*. Springer, Berlin, 2008.
- [11] P. Hell and J. Nešetřil. *Graphs and Homomorphisms*. Oxford Lecture Series in Mathematics and Its Applications. OUP Oxford, 2004.
- [12] Richard Hammack, Wilfried Imrich, and Sandi Klavžar. *Handbook of product graphs*. Discrete Mathematics and its Applications (Boca Raton). CRC Press, Boca Raton, FL, second edition, 2011. With a foreword by Peter Winkler.
- [13] Peter H. Welch and Jeremy M. R. Martin. A CSP model for java multithreading. In *International Symposium on Software Engineering for Parallel and Distributed Systems, PDSE 2000, Limerick, Ireland, June 10-11, 2000*, pages 114–122, 2000.