



Energy Research in Sagarmatha  
National Park and Buffer Zone,  
HKKH Project of EV-K2-CNR

By  
Prof. Dr. Ramesh Kumar Maskey  
And  
Team  
Kathmandu University



# The Team





**Location:**

27°45'19"-28°07'41"N

86°28'19"-87°07'41"E

**Area covered:**

**SNP-1148km<sup>2</sup>**

**BZ – 287.04 km<sup>2</sup>**

**Elevation ranges-2800m – 8848m**

**Park declared: 1979**

**UNESCO World**

**Heritage Site: 1981**



# Presentation Outlines:

- Objectives
- Kathmandu University Activities
- Energy Management in SNPBZ
- Energy Model
- Further Work





# Aims



- to develop an effective energy management system that must balance with energy demand through appropriate energy supply in sustainable manner in SNP & BZ.

In detail, it aims to:

- Identify the current energy consumption pattern and future demand.
- study on the availability of non-conventional energy sources to replace/retrofit the use of conventional energy source.
- Apply the best practice architectural design to reduce energy demands and to maximize the use of energy-efficient utilities.
- suggest the need for awareness and capacity building activities in energy management



# Kathmandu University Activities

- **Activity No. 1** Establishment of the participatory process
- **Activity No. 2** Training and capacity building
- **Activity No. 3** Contribution to the development and validation of the qualitative analysis and to the data gap-analysis and data collection to provide the information required by the model
- **Activity No. 4** Definition of storage data format
- **Activity No. 5** Research activity in the field
- **Activity No. 6** Divulgation of the research activity and results
- **Activity No. 7** Contribution to the development of the new SNP management plan



# Kathmandu University's Field work



## September 2007 Field Visit

- Lukla – Chhukung (25 settlements)

## May 2008 Field Visit

- Lukla – Evt. Base camp and Gokyo (32 settlements)
- Questionnaire (Demand/Supply)
- Measured components of building like, wall thickness, room dimension, building materials
- Spot measurement of solar irradiation, wind velocity, river discharge



# Surveyed Location Map

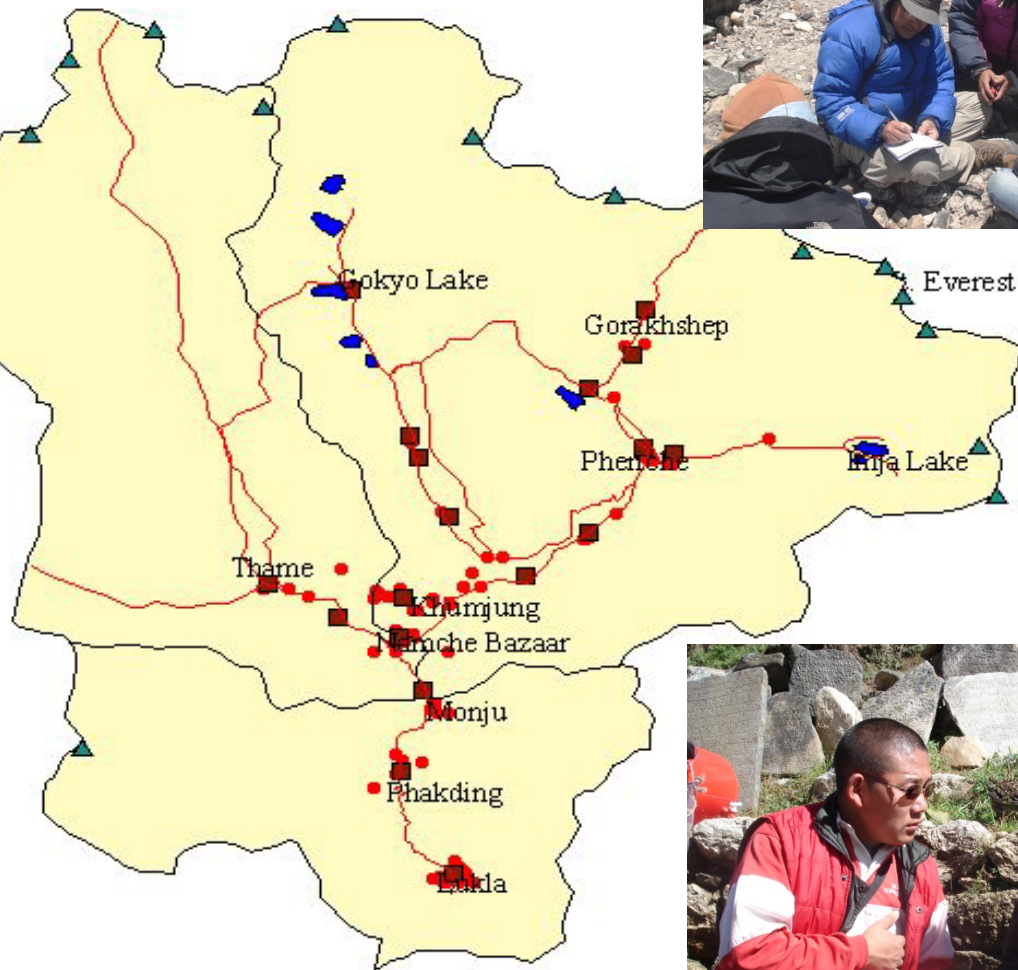
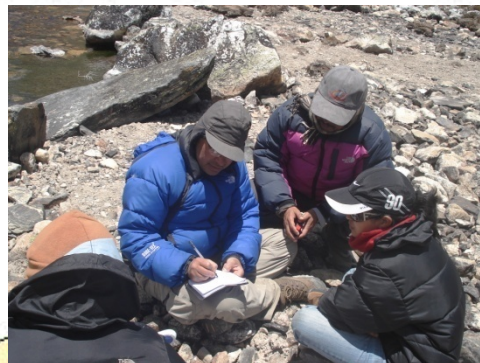

## Legend:

- ▲ Major Peaks
- Lakes
- Main trails
- Major villages
- Vdc boundary
- Survey Locations
- SNP BZ

10 0 10 Kilometers







# Discharge Measurement in SNPBZ

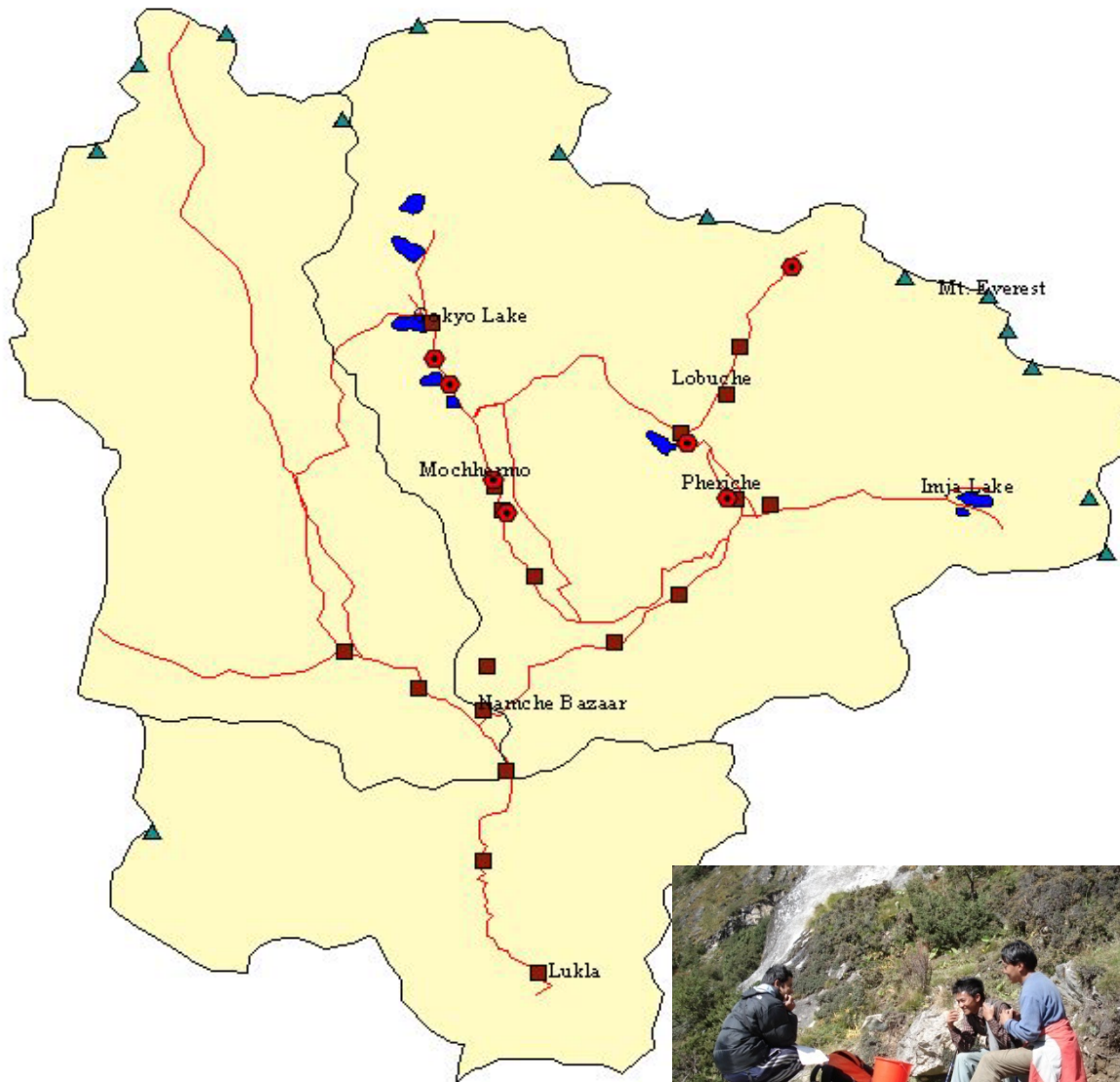

- Discharge measurement
- Major villages
- △ Vdc boundary
- Lakes
- ~ Main trails
- ▲ Major Peaks
- SNP BZ

10 0 10 Kilometers



# Measurement of Wind Velocity and Solar Irradiation



## Legend

- Wind speed measurement location
- Major villages
- △ Vdc boundary
- Lakes
- Main trails
- ▲ Major Peaks
- SNP BZ

10 0 10 Kilometers





# ENERGY MANAGEMENT IN SNPBZ

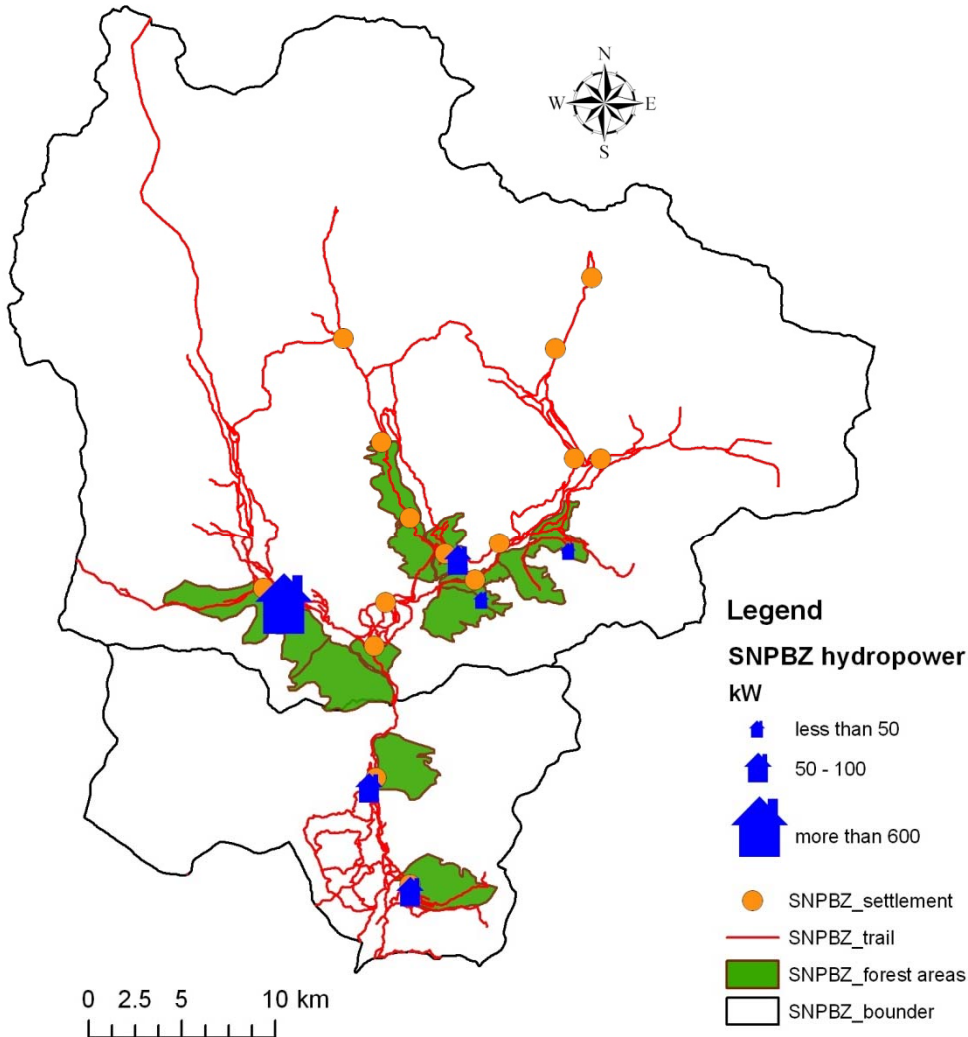

- SNPBZ's area: around 1300 km<sup>2</sup>
- No. of hydropower stations in SNPBZ: 6, for a total power amount of 900 kW (Khumbu Bijuli Company: 630 kW)
- Total Energy Demand in SNPBZ: 60,000 kWh/day ( from 40,000 kWh/day in July to 80,000 kWh/day in October)



# CURRENT ENERGY DEMAND AND SUPPLY SCENARIO



## Current Energy Demand

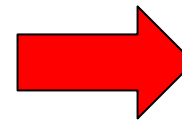
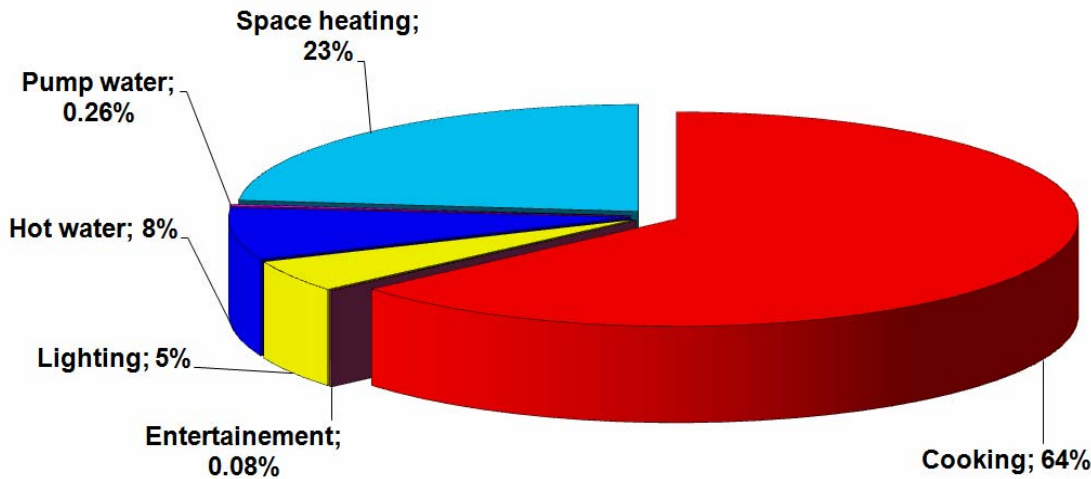

**Cooking: 64%**  
**Space heating: 23 %**  
**Others: 13%**

## Current Energy Supply

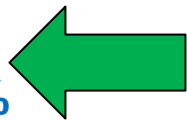
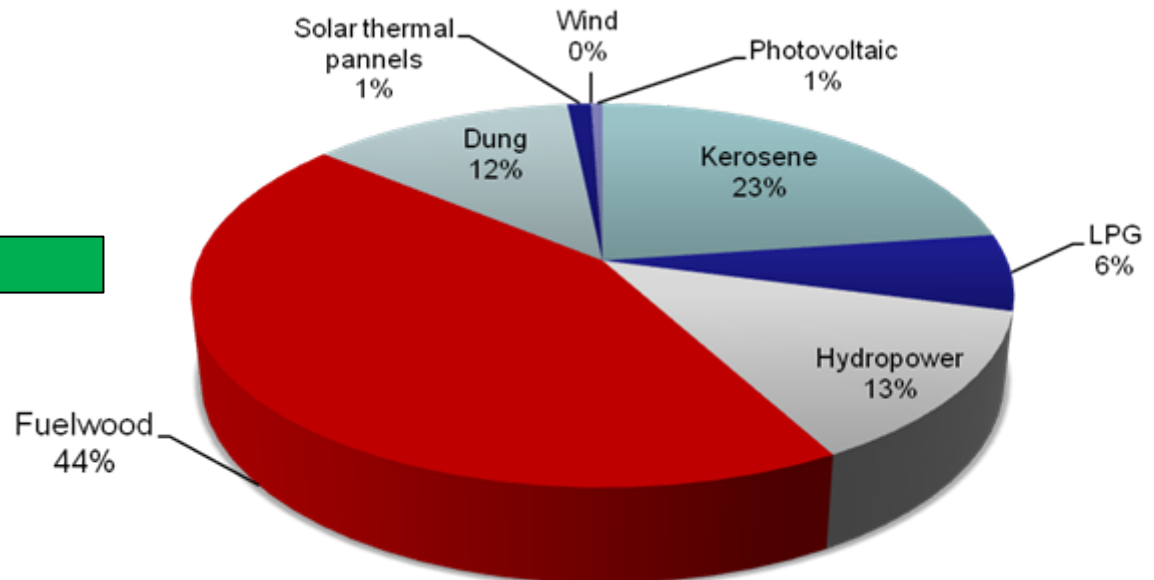

**Indeginous: 56%**  
**Commercial: 29%**  
**Non-Conventional: 15%**





# THE ENERGY MODEL



The model allows assessing different energy scenarios to:

- Explore and discover current and future energy consumption patterns;
- Assess options and potentials regarding substitution of conventional energy sources based on non-conventional energy sources;
- Evaluate options to reduce the overall energy demand by improving insulation of buildings and promoting the use of energy-efficient utilities;
- Discover the most effective energy awareness raising and capacity building activities.



# Qualitative model (CMAF)

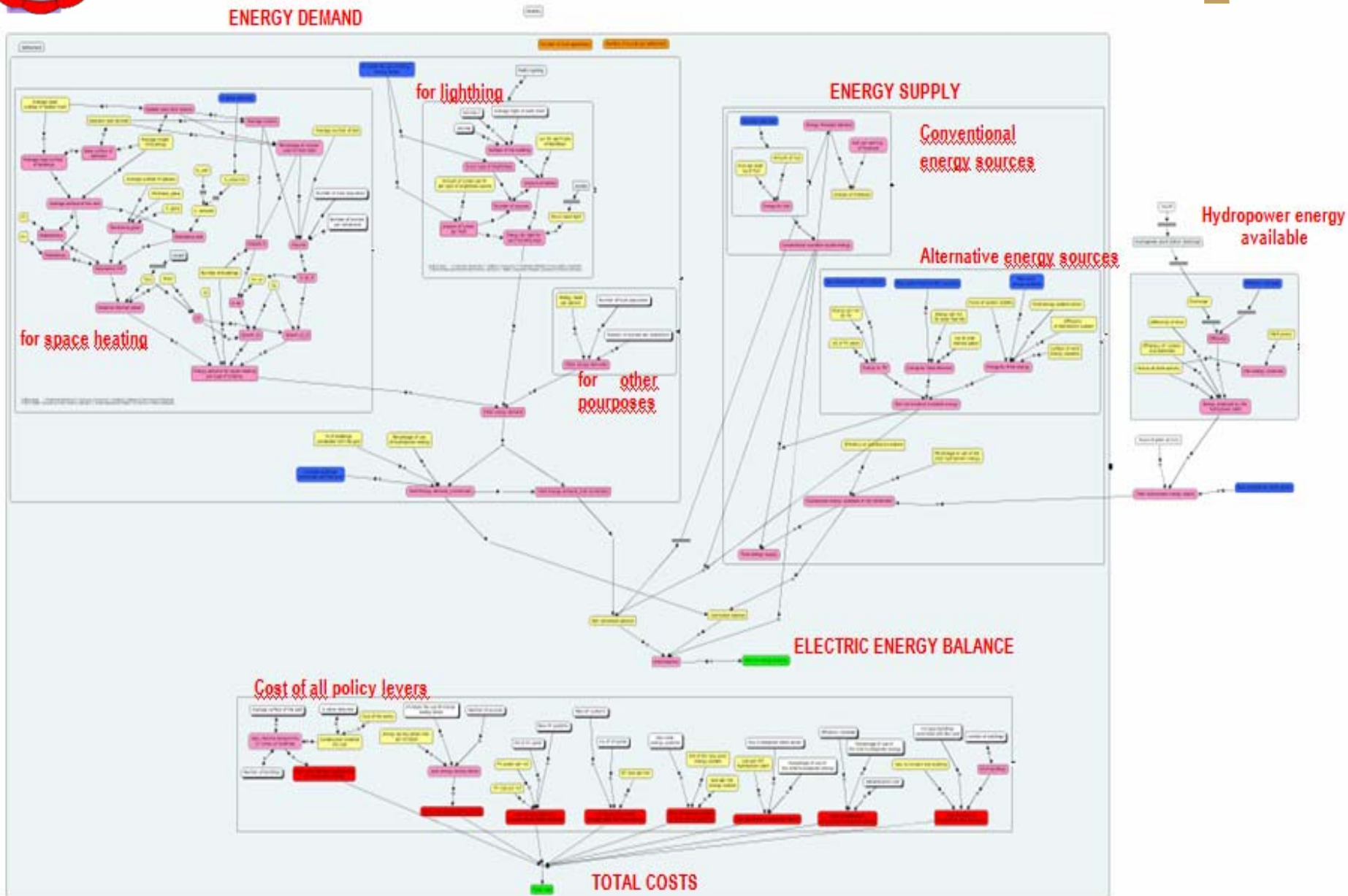





# Quantitative model (Simile)

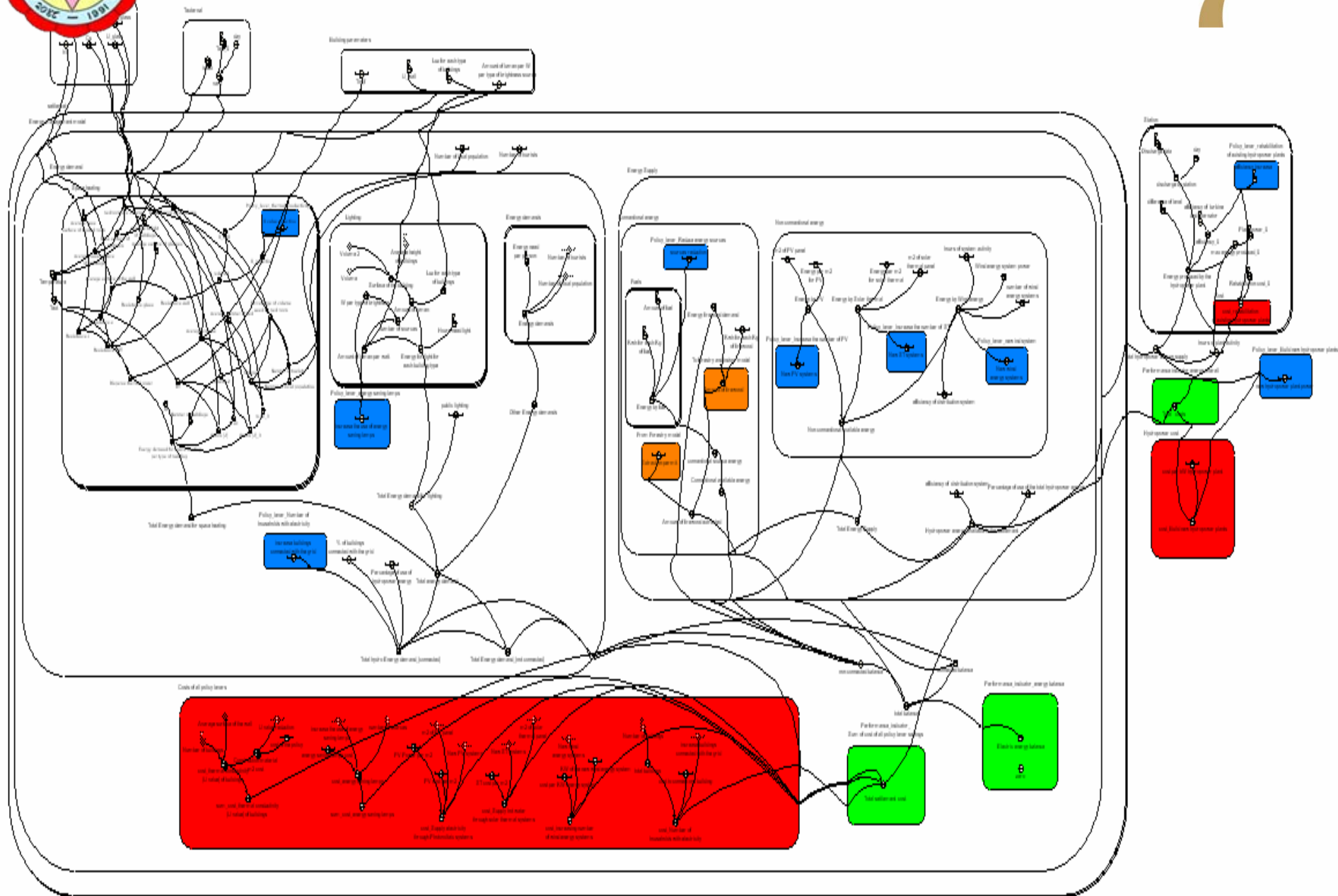



# The model output: performance indicators

The main performance indicators of this model are:

- **Energy balance:** represents the total balance between energy supply and energy demand in each settlement.
- **Total cost:** the implementation of the management levers is associated with financial cost. This indicator simply sums up the cost for all management levers as set by the user. If no management action is taken – all management levers set to 0 – this indicator will be 0 and the model will run based on a “business as usual”-scenario..



# ENERGY MANAGEMENT IN SNPBZ



At park level (SNPBZ) the yearly deficit is around **7%** ( $\pm 5\%$ )

...and at single settlement level

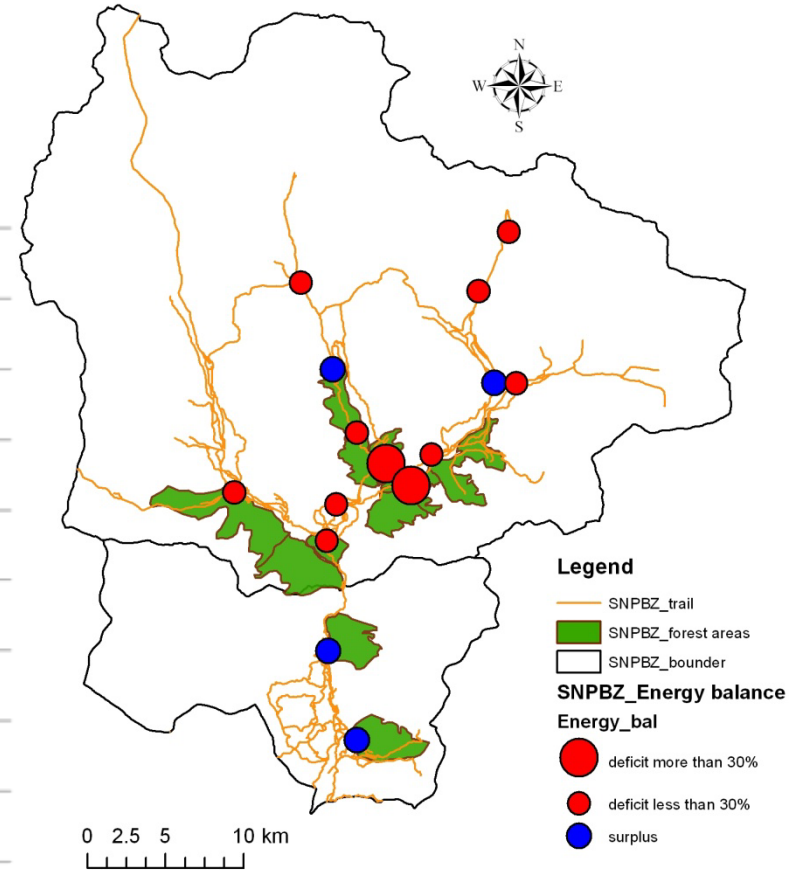
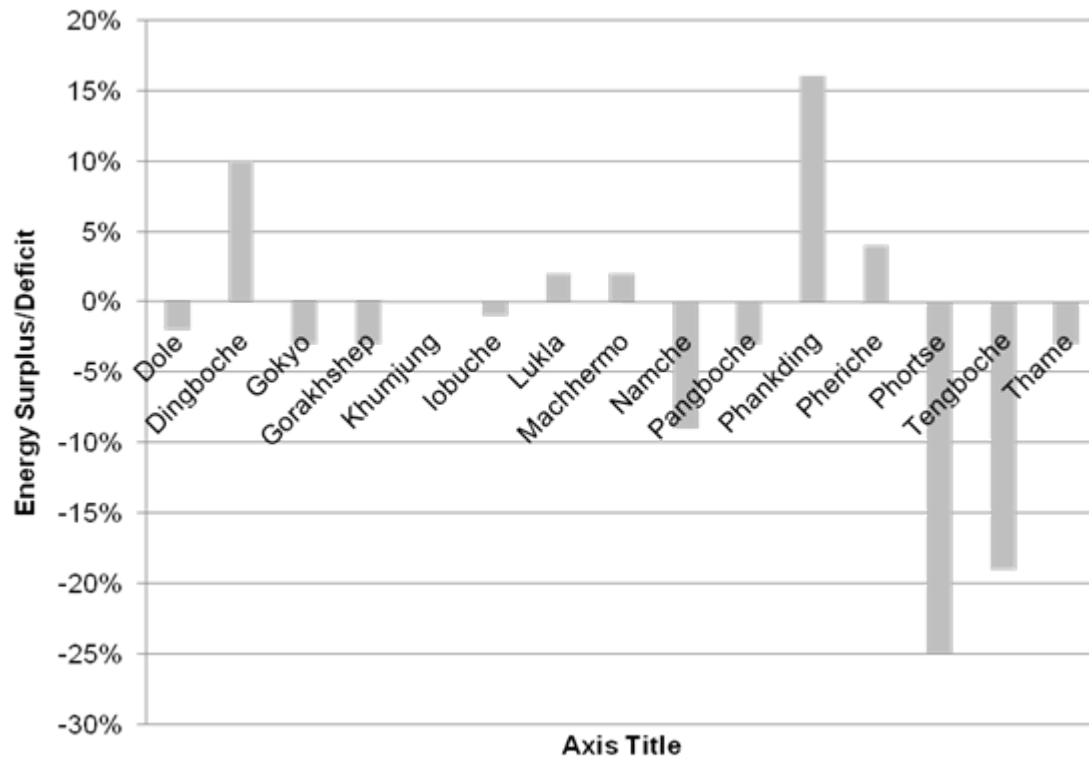





# Scenario 1:

How is it possible to decrease the energy demand?

## 1. Introducing energy saving lamps

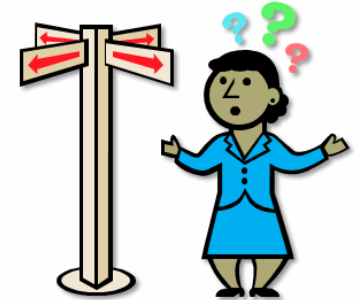
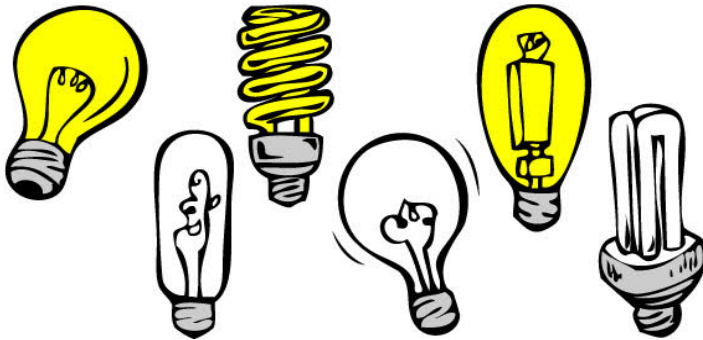

## 2. Decreasing the thermal conductivity of buildings, in other words improving the insulation

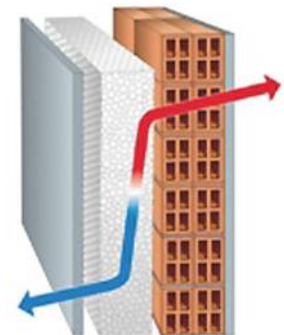
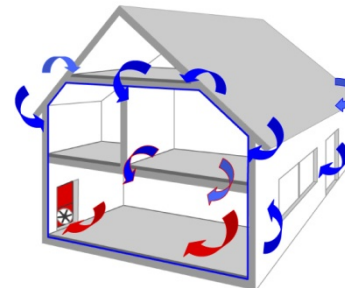



# Scenario 1: Decrease of the energy demand

At park level, the energy balance shifts from a deficit of 7% to a surplus of 7% (possible error  $\pm 5\%$ )



+ 14 %

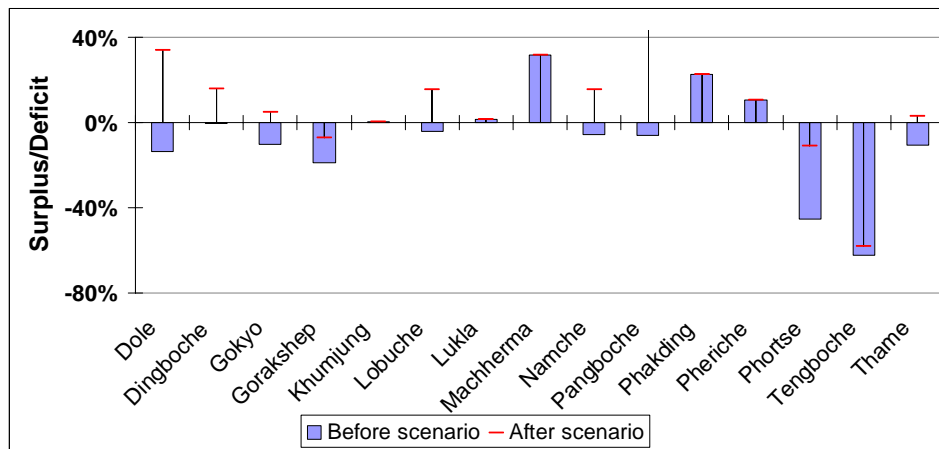

.....at local level

The investment cost of this management policy is **6.6 mln NRs** for all SNPBZ

Consumption costs: **300,000 NRs/day** for all SNPBZ



## Scenario 2: Which alternative energy source could be proposed to reduce the current deficit??

2a) Introduce a micro-hydropower station to fill the energy deficit of each settlement

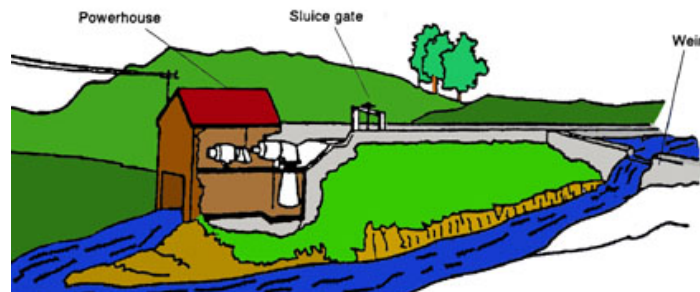

2b) Introduce solar thermal panels to cover the energy demanded for hot water, plus an hydropower station to support the remaining deficit

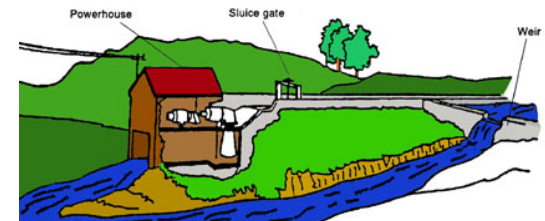





# Scenario 2a: A new hydropower station/more hydropower stations supplying 700 kW

At park level the balance shifts from a deficit of 7% to a surplus of 3% (Possible error  $\pm 5\%$ )

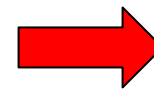

+ 10 %

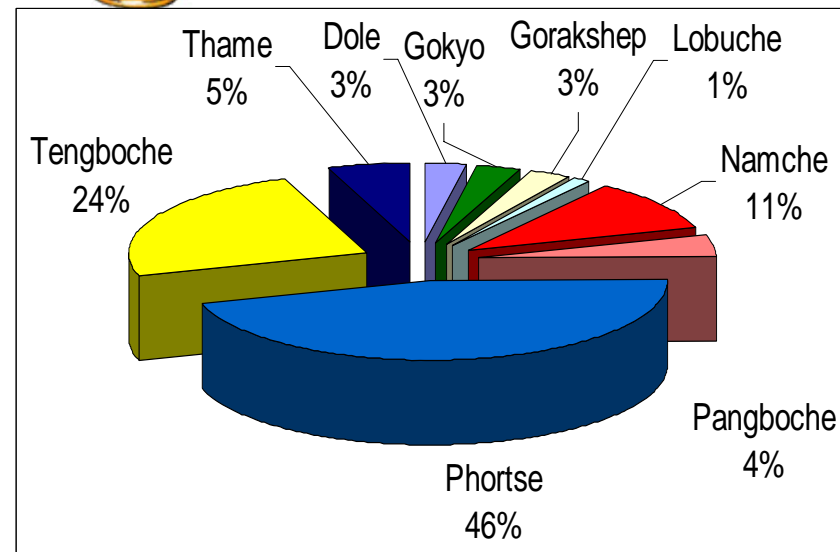
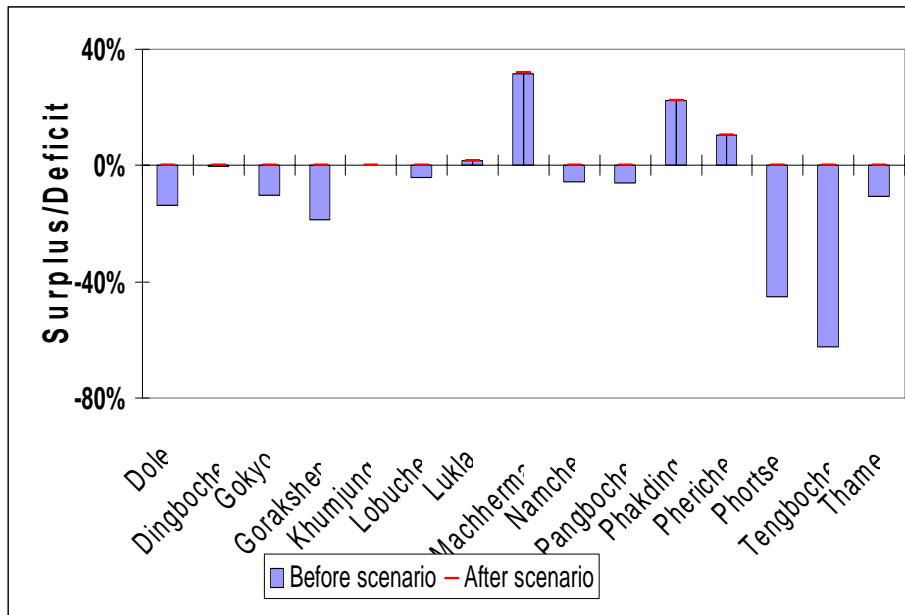

The investment cost of this management policy is **168 mln NRs** (plus possible costs to create new electric grids)

Consumption costs: **350,000 NRs/day** for all SNPBZ



# Scenario 2b: Solar thermal panels for 270 m<sup>2</sup> and a new hydropower station/more hydropower stations supplying 500 kW

At park level the balance shifts from a deficit of 7% to a surplus of 3% (Possible error  $\pm 5\%$ )

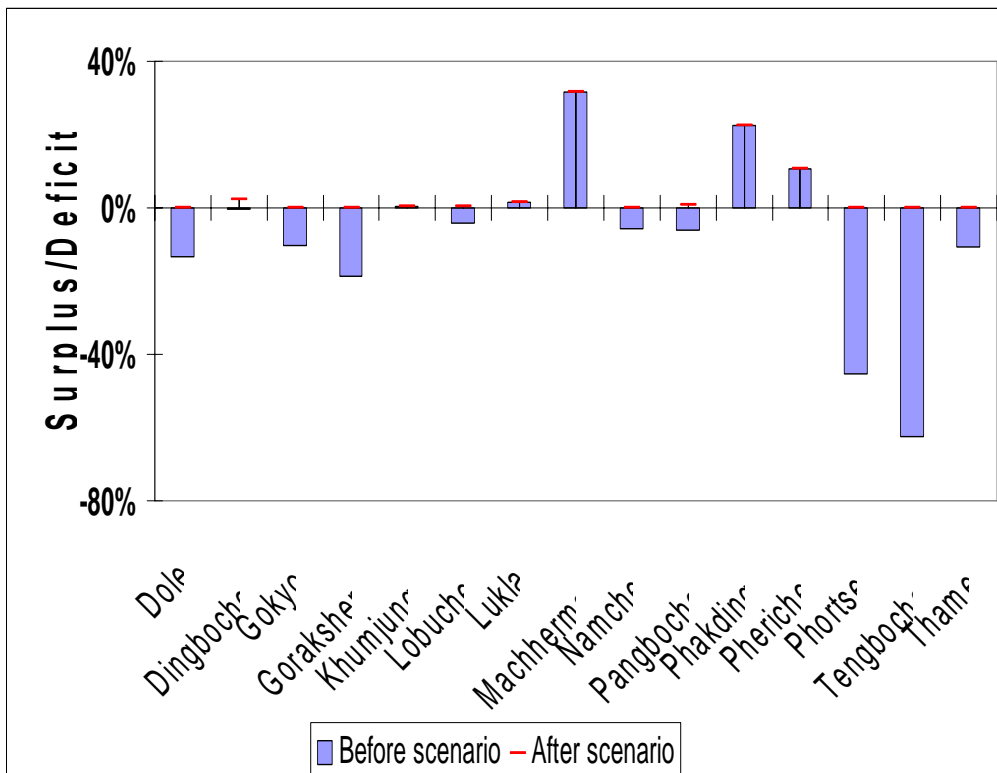

+ 10 %

.....at local level



# Comparison of Household Energy Use in Khumbu region

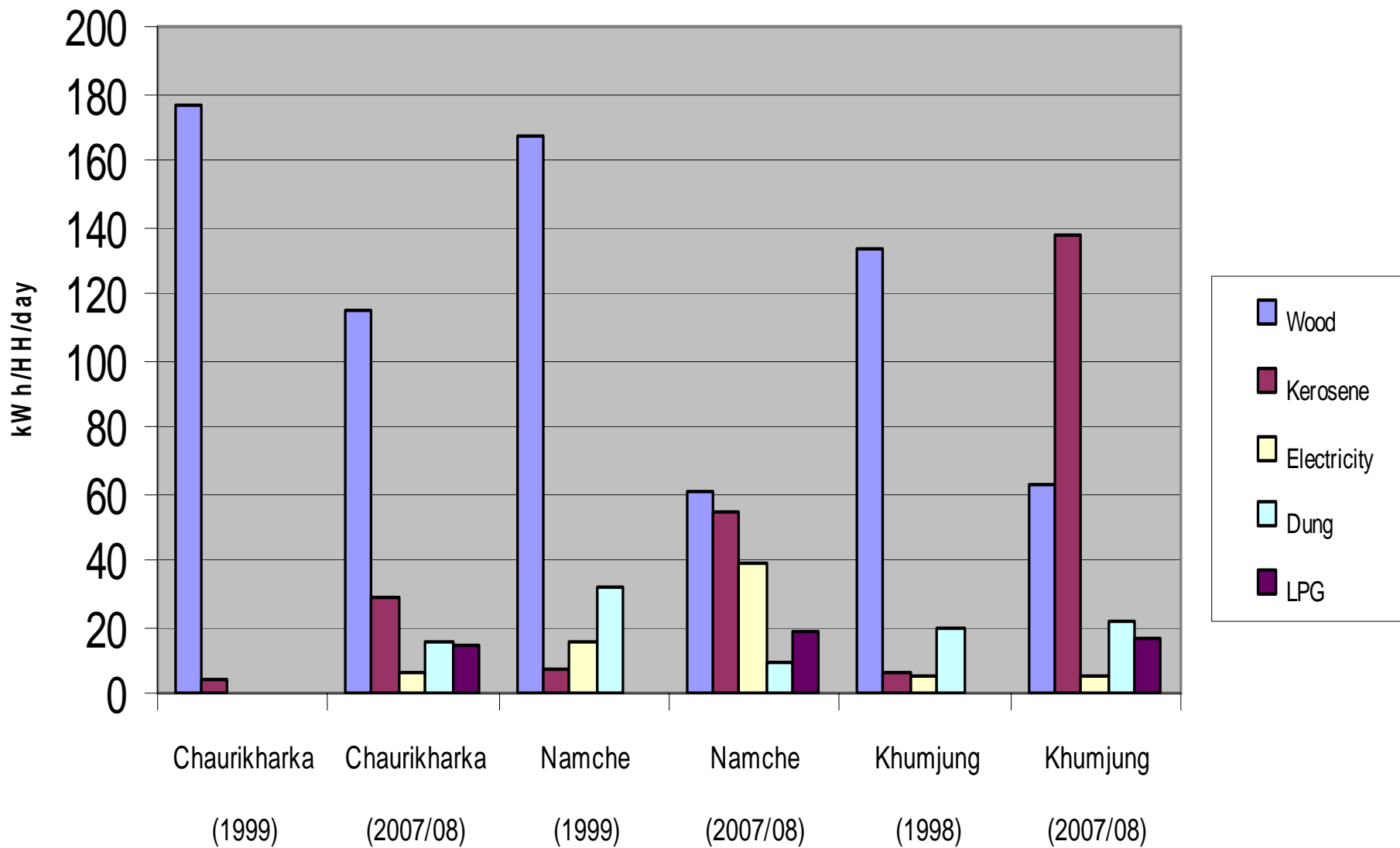





# Energy used and CO<sub>2</sub> emission from different household activities

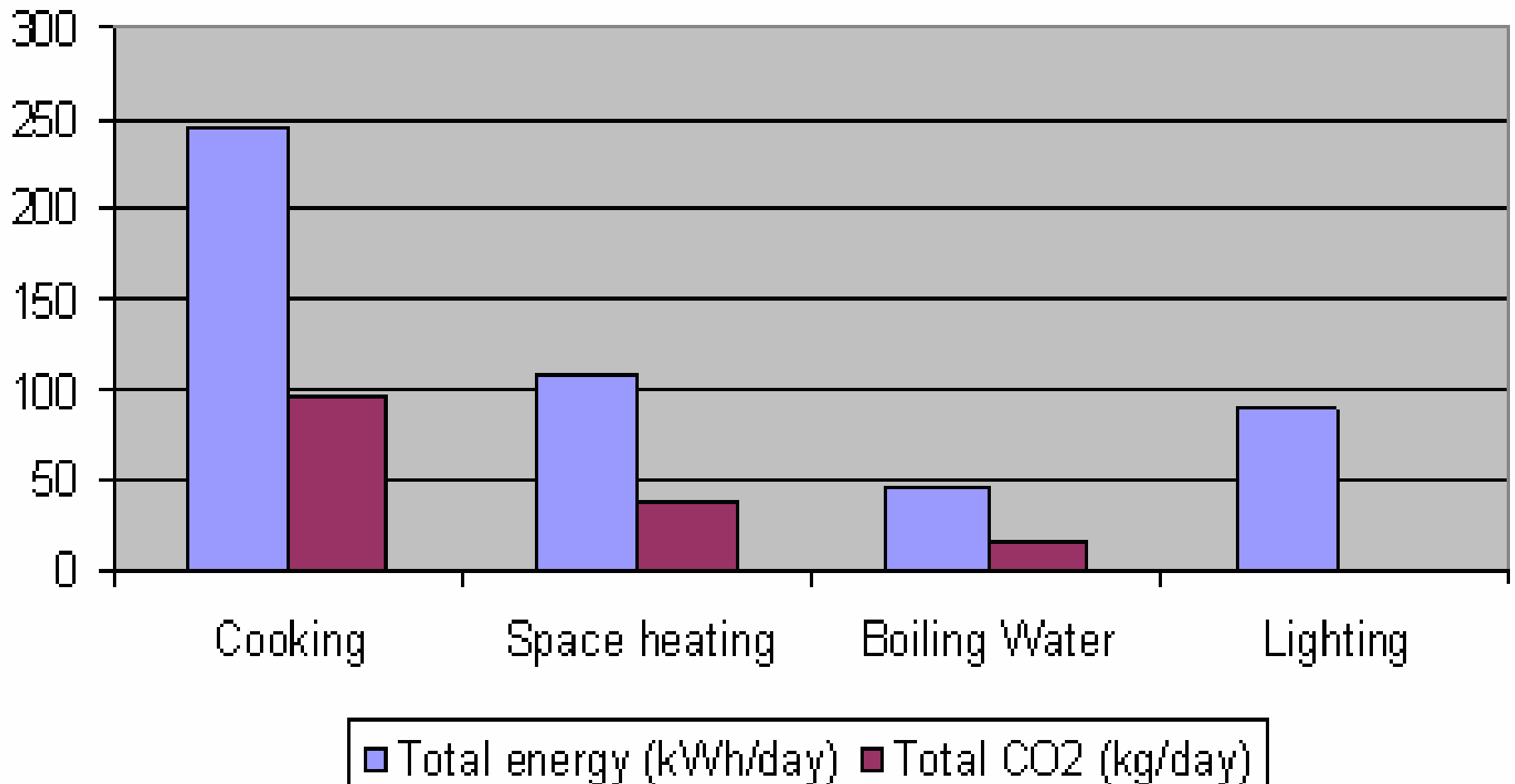

traditional

# Thermal Insulation....

Based on architecture and construction materials:

- **Traditional type:** Local materials
- **Semi-modern/ Medium type:** Commercial + local material (limited insulation)
- **Modern type:** Commercial + heavy insulation



medium



modern



# Comparison of Energy- efficiency in different types of building

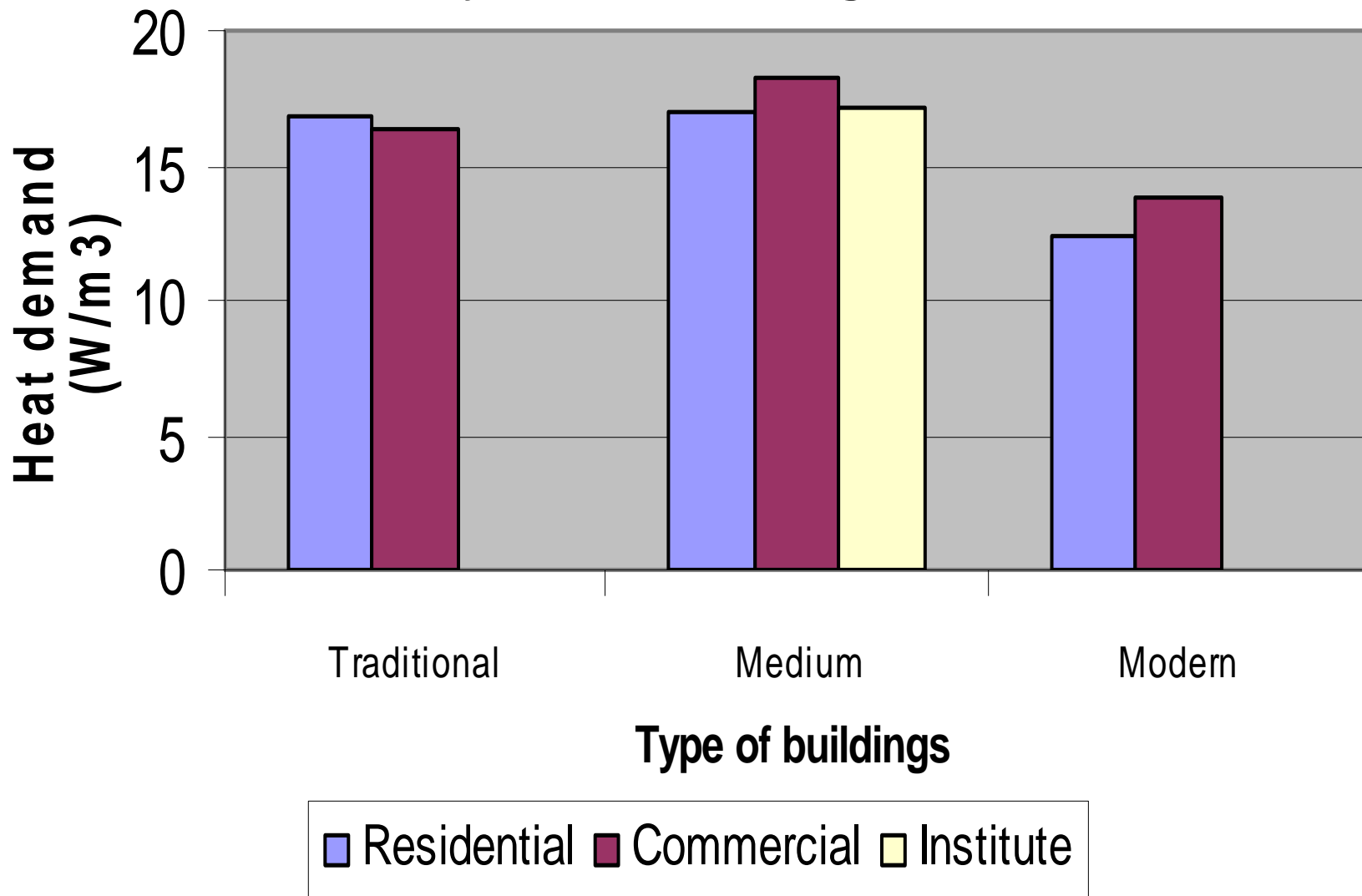



# Reduction in CO2 emission by use of proper insulation

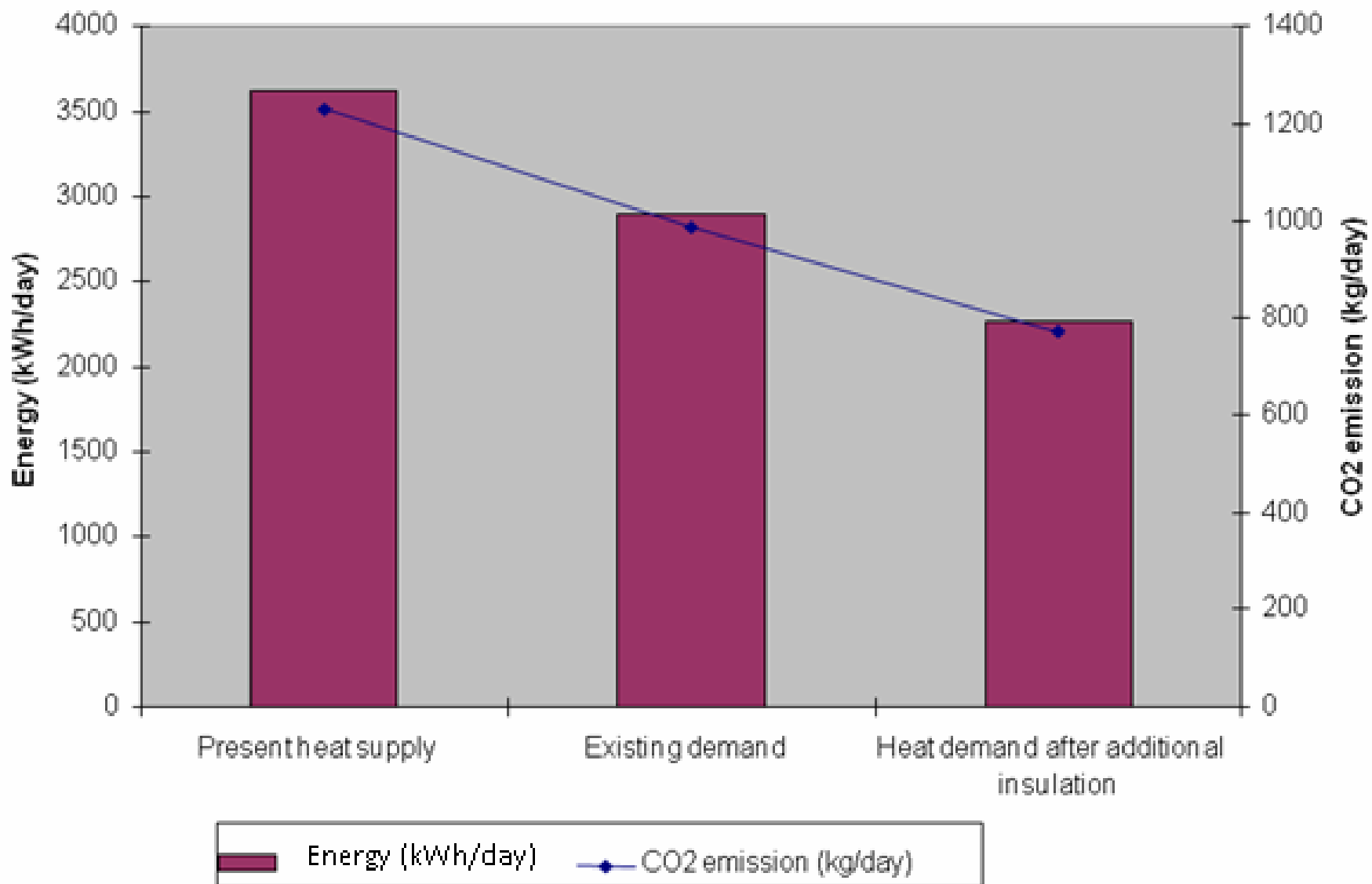





# Further Work.....

## Study on the Thermal Efficiency of Insulation Material made up of Locally Available Material at SNPBZ



Fig: Mixing material



Fig: Preparation of Insulation tile



Solar dried of tile

### Material Used:

- Kamero (White Soil)
- Cow dung
- Wooden grain
- Rice husk
- Plastic grain from Mineral Water Bottle (the major waste of SNPBZ)
- Paper
- Brick Powder



# Preparation of model room

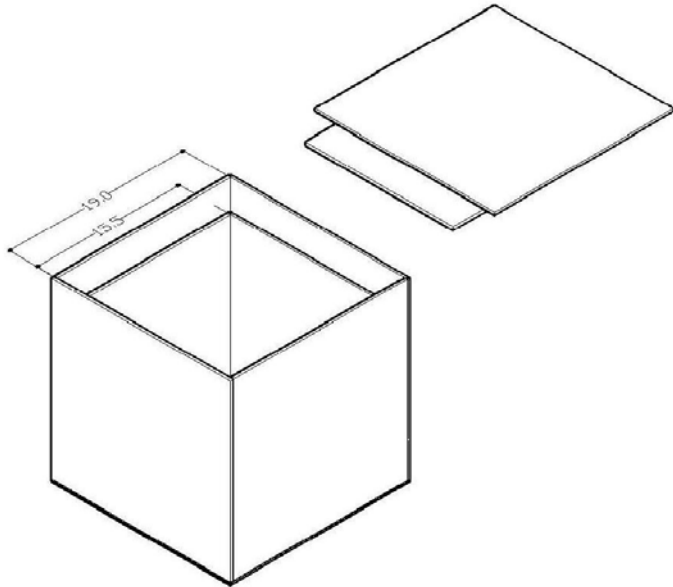





# Testing of Material





# Results

<b>Types of insulating material</b>	<b>Thickness (m)</b>	<b>Thermal Conductivity (W/mK)</b>	<b>R (m<sup>2</sup>K/W)</b>	<b>U (W/m<sup>2</sup>K)</b>
Empty box	0.025	1.023	0.046	41.056
Sterofoam	0.032	0.078	0.402	2.521
Option 1(Kamero, Wooden grain, cow dung)	0.025	0.092	0.281	3.633
Option 7 (Kamero, Wooden grain, plastic thread, cow dung)	0.032	0.075	0.423	2.413
Option 2(Kamero, Rice husk, cow dung)	0.025	0.094	0.275	3.734
Option 10 (Kamero, Brick powder, cow dung)	0.025	0.096	0.275	3.639
Option 13 (Kamero, paper pulp, cow dung)	0.032	0.075	0.427	2.370
Option 11 (Kamero, paper pulp, cow dung, baking powder)	0.025	0.089	0.296	3.439



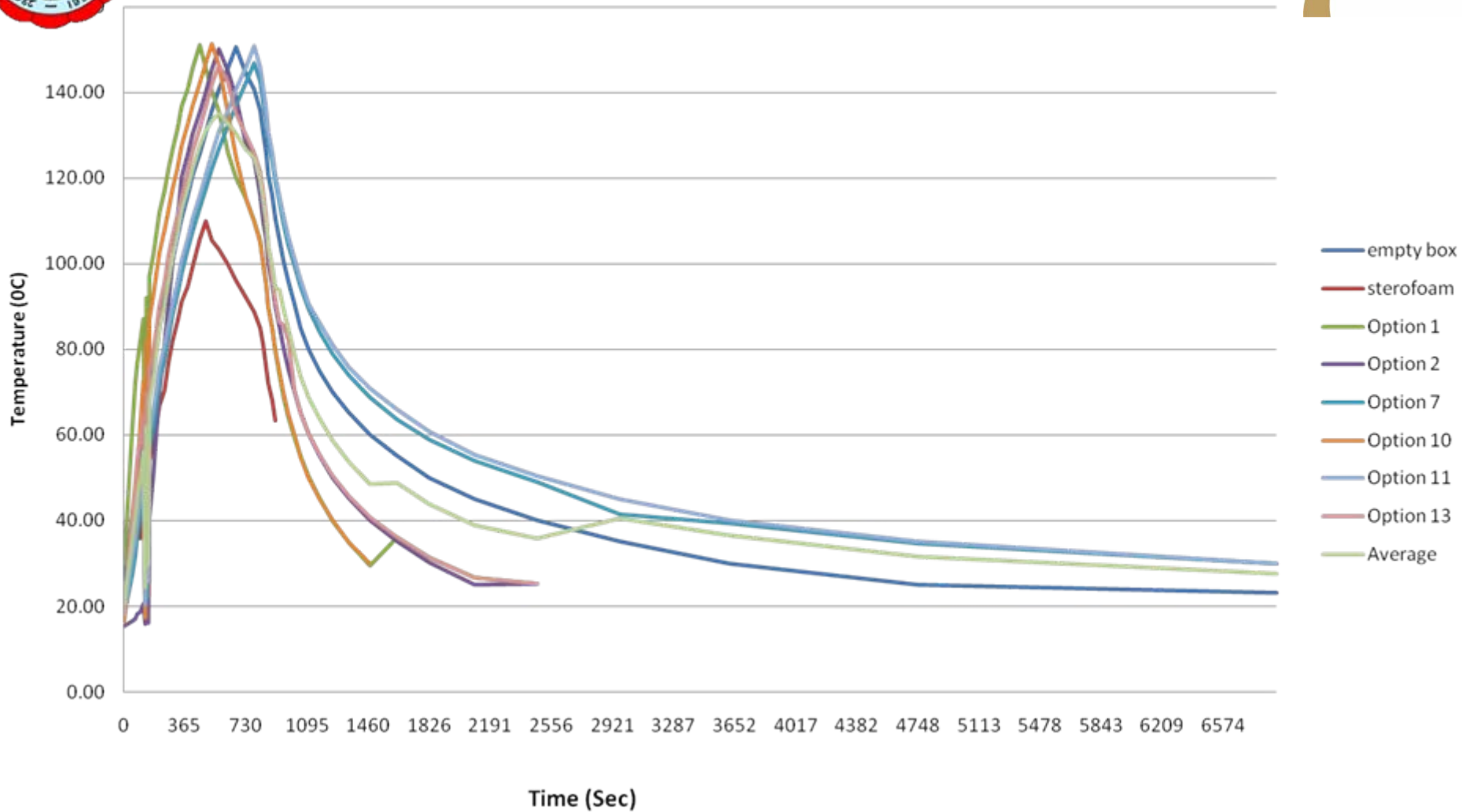

Graph: Temperature vs. Time



# Some Photo Documentation

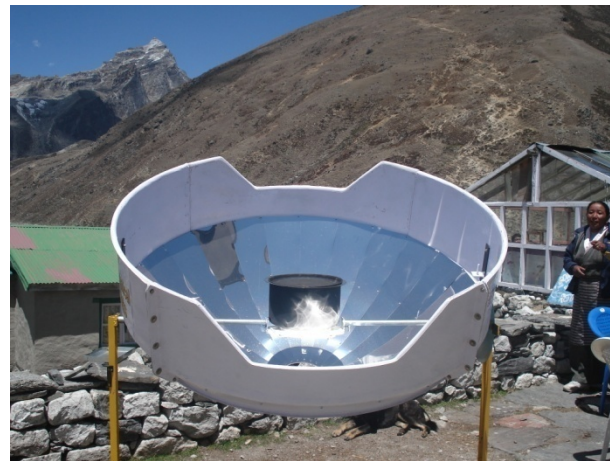



***Thank you!***

