

International Gas Union

# 23<sup>rd</sup> World Gas Conference 2006

June 5-9, 2006  
Amsterdam, The Netherlands

Volume 1 of 5

**Printed from e-media with permission by:**

Curran Associates, Inc.  
57 Morehouse Lane  
Red Hook, NY 12571  
[www.proceedings.com](http://www.proceedings.com)

**ISBN: 978-1-60423-757-3**

**Some format issues inherent in the e-media version may also appear in this print version.**

**23rdWorld Gas Conference, Amsterdam 2006**

**REINFORCED THERMOPLASTIC PIPELINE (RTP) SYSTEMS FOR  
GAS DISTRIBUTION**

**Mannes Wolters**

**University of Twente/Kiwa Gastec Technology, The Netherlands**

**Werner Wessing, Eon-Ruhrgas, Germany**

**Bert Dalmolen, Pipelife, The Netherlands**

**Robert Eckert, Friatec, Germany**

**Juergen Wuest, SKZ-TeConA, Germany**

## ABSTRACT

Presently for pressures up to about 10 bar, plastic pipeline materials (like PE ) are the preferred option. Up to now a suitable plastic pipeline system for pressures up to about 16 bar is not available. In this paper a tailor-made fibre-reinforced thermoplastic pipeline (RTP) system ( pipes and joints ) is described, which is a cost-effective option for use in gas distribution systems up to about 20 bar. Development and qualification of such a system was a joint effort of various European gas companies, universities and test institutes, and a pipeline and fitting manufacturer. To date RTP has been used primarily in oil, gas and water applications at high pressures, where the material has proven to be more cost-effective than steel. The suitability of the RTP system has been assessed by performing many mechanical and physical tests on the system components and joints. Much attention has been given to determine the long-term behaviour under internal pressure. The resistance to third party damage has also been assessed by carrying out full-scale field tests. Special attention has been given to develop a relatively simple and cheap jointing technique, based on the well-proven electrofusion jointing technique for conventional PE pipelines. In long-term tests it has been shown that the strength of these joints outperforms the strength of the pipeline materials. It is also shown that this new pipeline system fulfils the requirements of recently issued (draft) specifications for such pipeline systems for gas ( e.g. ISO and German (DVGW) specifications ). The results of the various physical and mechanical tests show that this RTP system has a performance fulfilling all the requirements of the (draft) international specifications. The long-term (50-year) strength of this system exceeds 42 bar and in all tests the joints are stronger than the pipeline material. The RTP system is also resistant to third party digging activities. The RTP system is a cost-effective option for situations where long lengths of pipes can be installed, like so-called ploughing techniques. In these situations the pipes can be installed in long lengths (200 to 300 meters ) from coils. In this case only a few joints have to be made, thereby reducing construction costs. Compared to steel systems, considerable cost reductions, in the order of 25 %, can be obtained. Presently these RTP systems are available in 4" (100 mm ) and 5" (125 mm).

## TABLE OF CONTENTS

Abstract

1. Introduction
2. RTP systems for high-pressure applications
3. A tailor-made RTP system for gas distribution
  - 3.1. Pipe material
  - 3.2. Jointing techniques
4. Pre-conditions for market introduction
  - 4.1. Availability of specifications
  - 4.2 Safety and risk analysis
  - 4.3 Cost evaluation
5. Conclusions
6. References

## 1. INTRODUCTION

In gas distribution systems various pressure stages are distinguished, like e.g. a pressure step up to 0.1 bar, 4 or 5 bar and 16 bar respectively. In some countries gas distribution pressures may even go up to about 25 bar. Presently for pressures up to about 10 bar, plastic pipeline materials (like PE ) are the preferred option. Up to now a suitable plastic pipeline system for pressures up to 16 bar is not available. Various plastic-based pipeline systems for these higher pressures are being developed at the moment.

In this paper a fibre-reinforced thermoplastic pipeline (RTP) system ( pipes and joints ) will be described, which is a cost-effective option for use in gas distribution systems up to about 20 bar. Development and qualification of such a system was a joint effort of various European gas companies, universities and test institutes, and a pipeline and fitting manufacturer. To date RTP has been used primarily in oil, gas and water applications at high pressures, where the material has proven to be more cost-effective than steel.

In this paper first a summary of the properties of RTP systems for high-pressure applications will be given. This will clearly show that these systems are “over-qualified” for use in gas distribution systems and that the costs of these systems are much too high.

Therefore a more tailor-made RTP system for low-pressure gas distribution systems has been developed. The costs for installing such systems should also be competitive to those of conventional steel pipeline materials. This RTP “light” system will be described and the performance will be illustrated by various experimental results. An important part of the system is the development of an innovative jointing system based on the electrofusion technology of PE pipe systems.

In the paper the pre-conditions for a successful market introduction will also be discussed. This includes the availability of specifications, a risk and safety analysis, and a cost evaluation of the complete system. The paper will end with a number of conclusions.

## 2. RTP SYSTEMS FOR HIGH-PRESSURE APPLICATIONS

Reinforced thermoplastic pipe (RTP) is a possible alternative to steel pipelines for high-pressure applications ( ref. 1 ). The material is relatively new to the gas industry, but has been tested and approved in the Middle East and Europe for oil, gas, and water applications at

pressures approaching, or even exceeding 100 bar (pressure rating depends on fluid, temperature, safety factor, and pipe construction).

Reinforced thermoplastic pipe (RTP) is manufactured by wrapping a conventional fluid tight plastic pipe (e.g., polyethylene) with high strength fibers. An outer cover is typically added to protect and secure the fiber layer. A typical three-layer RTP is shown in Figure 1.



*Courtesy of Soluforce*

***Figure 1. Typical RTP Construction***

The inner liner pipe is typically high density polyethylene (HDPE), which is widely used for many fluid applications including the distribution of natural gas. Other liner materials like PEX, PVDF, etc. may be applied as well. For the fiber layer, manufacturers have used aramid and polyester. Aramid fibers are exceptionally strong (same fiber used in bullet proof vests), and these fibers, when wrapped around the HDPE liner pipe, can increase the pressure capacity above 100 bar (varies with fluid type, temperature, safety factor, and pipe construction). Polyester fibers, while not as strong as aramid, are less expensive. With polyester fibers, pressure capacities up to about 25 bar can be achieved (again dependent on fluid type, temperature, safety factor, and pipe construction). The outer cover is generally an extruded layer of HDPE. This cover helps secure the fiber layer and provides additional protection from ambient conditions (e.g., UV protection in above ground applications). The outer cover does not provide a

significant contribution to the pressure capacity of the pipe – the liner pipe and the fiber layer provide the majority of the pressure carrying capacity.

The key properties that make RTP an attractive option relative to steel include:

- High pressure rating (well above 10 bar, which is the upper limit for the use of PE in natural gas distribution)
- Excellent corrosion resistance (all polymer construction)
- Low cost installation (much like typical PE), mainly originating by the possibility of coiling the pipe
- A very high impact strength; the thermoplastic matrix is very tough, while the reinforcing jacket provides even more impact strength

RTP is a relatively new material for natural gas applications and there are limitations, which include:

- Narrow range of pipe sizes currently available (4 to 6 inch diameters are common)
- Limited selection of fittings and service connectors
- Specialized installation equipment and operator training required for installation (equipment and training generally available from RTP manufacturers)

RTP is produced by various manufacturers, including Pipelife, Coflexip, and Wellstream. To date, RTP has been used primarily in oil, gas, and water applications where the material has proven to be more cost effective than steel. Among the manufacturers, Pipelife has been particularly active in promoting RTP, and the company has installed over 200 km of RTP. RTP has been used primarily in the Middle East and in Europe. In these locations, the material has generally been used in above ground applications for oil and gas gathering lines. Field trials with natural gas distribution have recently been initiated in Europe ( ref. 2 ).

To connect the long lengths of pipes ( 200 – 400 meters ) special in-line pipe couplers and end-fittings are used. Both fittings are based on the electrofusion technology. Basically they consist of a specially designed glass-fibre reinforced sleeve, with an integrated copper heating wire. This sleeve is welded on the outside of the RTP pipes. In case of the in-line couplers, the liners (PE) are first butt-welded to each other to provide a leak-free connection. After that, electrofusion of the sleeve on the RTP pipes is carried out.

The long-term performance of these piping systems has been confirmed by internal pressure creep rupture testing at various pressures and temperatures. A long-term strength value at 50 years exceeding 110 bar at 65 deg.C has been assessed using the international accepted ISO methods. Internal water pressure tests have been carried out as well on joints in RTP systems. In all of these tests final failure occurred in the pipe, showing that the joint is stronger than the pipe.

### **3. A TAILOR-MADE RTP SYSTEM FOR GAS DISTRIBUTION**

#### **3.1. Pipe material**

The classic RTP pipe material is clearly “over-qualified” for the use in gas distribution systems. This material is very strong and can be used up to very high pressures, in the order of 80 – 120 bar, at the operating temperatures for gas pipelines. However, this aramid-based RTP pipeline material is also rather expensive. For gas distribution the material should only be able to resist pressures up to about 25 bar. Because the costs of the RTP pipe material are mainly determined by the fibre material used, a cost reduction may be achieved by altering the fibre material, but still meeting the pressure requirements. As an alternative polyester fibres could be used instead of the aramid fibres. Polyester fibres are much cheaper and still can result in an RTP system fulfilling the requirements of a gas distribution system. Unfortunately these polyester-based RTP systems are more difficult to produce and shrinkage occurs by thermal effects. Therefore this option was not further elaborated.

Another alternative to obtain a cost reduction of the pipeline material is to decrease the amount of aramid fibres in the fibre layer. This way has been chosen to obtain a cost-efficient RTP pipe material for gas distribution systems. The amount of fibres was reduced to 40% of that of “classic” aramid-based RTP pipes. This material was extensively evaluated; below some results of these tests will be presented ( see also ref. 3 ).

To assess the 50-year strength of this aramid-based “light”RTP pipe basically Draft Technical Specification ISO/TS 18226 (2003) has been followed ( ref.4). For this aim internal pressure tests have been carried out at a number of pressure levels up to times up to 6,000 hours. Using the regression analysis described in ISO 9080 (2003) the 50-year value has been determined. Most of the tests have been performed at 65 deg.C. So the 50-year strength has also been determined at this temperature. This means that the 50-year strength at operating temperatures of gas distribution pipelines will be much higher. The average value of the 50-year strength at 65 deg.C



is 49.4 bar, whereas the value of the 95% confidence level of the 50-year strength is 44.4 bar. In all cases the failure type is in the pipe and is tensile failure of the aramid fibres.

These results have also been compared with the results on “classic” aramid-based RTP pipes. In table 1 the 50-year values are presented .

**Table 1. Long-term strength values (50 yrs) for “classic” and “light” aramid-based RTP pipes at 65 deg.C (4”, 100 mm pipe)**

<i>Material</i>	<i>average value (MPa)</i>	<i>lcl value (MPa)</i>
“classic”	112.8	101.9
“light”	49.4	44.4

It can be seen that the 50-year strength values of the “light” pipes exceed 40% of the values of the “classic” pipes, which may be expected because the aramid content has been reduced to 40% of that of the “classic” pipes. This proves that the “light” and “classic” aramid-based RTP pipes belong to the same product family. This is also proven by the slope of the regression lines for both types of pipe.

The results of the internal water pressure tests could be described by the following relation:

$$\log (\text{failure time}) = C_1 + C_2 (\log p) \quad (\text{eq. 1})$$

In table 2, the values of  $C_1$  and  $C_2$  are given.

**Table 2: Results of regression analysis**

<i>Test data set</i>	<i><math>C_1</math></i>	<i><math>C_2</math></i>
65 °C, classic	39.7	-16.7
65 °C, light	35.7	-17.8

From these results it can be seen that the slope of the regression lines at 65 °C for respectively “RTP classic” and “RTP light” are about the same. This is evidence that RTP classic and RTP light belong to the same product family.

Taken the lower confidence limit of the 50-year strength for the “light” aramid-based RTP pipe, which is 44.4 bar, and using a design coefficient of 2.0, a maximum operating pressure of 22 bar is obtained. This holds for an operating temperature of 65 deg.C. This means that the MAOP (maximum allowable operating pressure ) at the usual operating temperatures ( 5 – 10 deg.C ) will be significantly above this value. This is illustrated by the 50-year strength for “classic” RTP pipes at 20 deg.C, which is more than 150 bar, compared with about 100 bar at 65 deg.C. For “light” RTP pipes tests are being carried out at 20 deg.C to confirm the test results at 65 deg.C.

The RTP pipeline material is built up of different layers. When transporting gas through this pipeline gas will permeate the inner line pipe wall and be accumulated in the fibre layer. This may lead to blow-off of the outer layer. Many tests have been performed to determine this behaviour. It has been found that at pressures below 42 bar ( at 65 deg.C) blow-off will not occur. This means that the MAOP of this RTP system for gas transport should be limited to 42 bar at maximum.

When transporting gas through pipelines so-called rapid crack propagation (RCP) may occur, destroying long lengths of pipe and resulting in large volumes of gas escaping from the pipeline. This is very dangerous and should be avoided by a good choice of material and operating the pipeline at the right conditions ( pressure, temperature ). Fortunately these RTP pipes are not vulnerable to RCP. An initiated crack will never propagate in axial direction through the pipeline, mainly caused by the wrapping of fibres over the inner pipe which prevents any crack growth in axial direction.

Another consideration in the use of RTP is third party damage. To better understand third party damage performance of RTP a number of field tests have been carried out. Most of the tests have been performed on a polyester-based RTP pipe, but it is assumed that the results will be the same or even better for aramid-based RTP pipes ( ref. 5 ). In these field tests the performance of RTP and steel have been simulated in third party damage situations. Two situations were simulated, i.e. a backhoe hitting buried pipe and hitting of the pipes caused by horizontal drilling equipment. These situations are considered to represent harsh, or near worst case, third party situations. The results showed that the RTP pipes are highly resistant to third party damage. Full direct hits over a wide area only superficially damage the RTP outer cover layer and will not affect

the pipe performance. Repair is not necessary or limited by applying a PE sleeve. Only in one situation, when the backhoe hits the pipe vertically on top of the pipe, a hole fully penetrating the pipe wall resulted. No RCP took place, however; the initiated crack was immediately arrested. In all other situations there is only limited damage to the RTP pipe and no leakage occurred. In most cases the resistance to internal pressure, in follow-up tests on the damaged pipes, was still satisfactory. The steel pipes also showed damage, though no leakage. However, the coating was sometimes damaged, which may effect long-term performance of the steel pipes.

### 3.2. Jointing techniques

The “light” RTP pipes can of course be jointed with the same jointing technique as used for “classic” RTP pipes, and this has been done successfully in practice already.

For the “light” RTP gas distribution system, however, a special jointing technique has been developed ( ref. 6 ). This method is based on the well-proven electrofusion technology for PE pipes. In fig. 2 such a joint is shown.

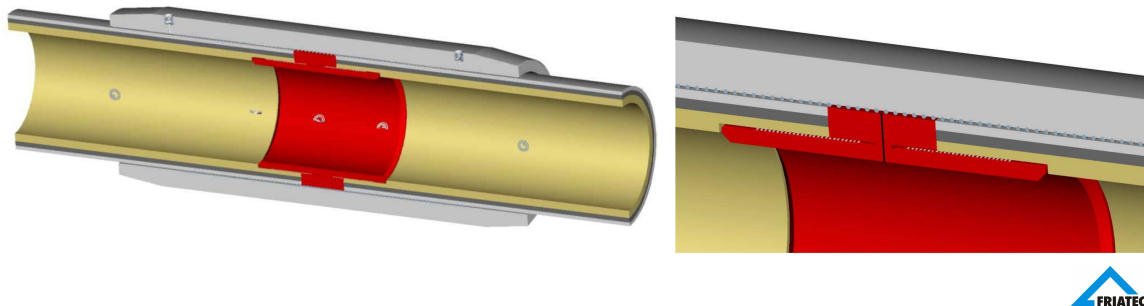

***Fig. 2. Jointing technique for the “light” RTP pipeline system : Final joint obtained***

In this jointing method first on the RTP pipe ends a kind of ring is welded . This ring is welded on the inside of the liner pipe by normal electrofusion. In this way gas cannot penetrate the fibre layer from the inside of the pipe .

A special scraper has been developed to scrape the inside of the PE liner pipe. After that a fibre-reinforced sleeve is moved over both pipe ends (having the ring welded on ). In this sleeve electrical wires are present. Before moving the sleeve over both pipe ends, the end of these pipes

have been scraped and be adapted to the required dimensions. Then electrofusion of the outer sleeve on the outside of the RTP pipes takes place.

Various tests have been carried out on these joints. First of all the resistance to internal pressure has been assessed. This was done by internal water pressure testing at elevated temperatures, like 80 deg.C. In all these tests failure occurred in the pipe ( tensile failure of the fibres ), which proves that the joints are stronger than the pipe material. This is also required in the draft specifications.

Axial tensile loading was also performed, which did not result in failure of the joints or the occurrence of any leakage. Moreover a bending test was performed on these joints using a bending radius of 1.5 meter for 4”(100 mm) pipe at 20 deg.C. After loading during 1 hour the joint was tested under internal water pressure at a pressure of 40 bar. No leakage or failure occurred.

## **4. PRE-CONDITIONS FOR MARKET INTRODUCTION**

### **4.1. Availability of specifications**

In gas pipeline systems usually only well-specified materials and components are used. To introduce a new pipeline system like RTP into the gas market therefore a full set of specifications should be available.

In this field a lot of progress has already been made. In ISO TC 138/SC4 , which committee is responsible for setting up specifications for plastic-based pipeline systems for gas supply, a draft specification has already been drafted ( ref. 4 ). This draft Technical Specification ( TS 18226 ) specifies requirements for pipes and joints. The maximum operating pressure of these systems is limited to 40 bar, though it may be used for guidance in the development of RTP systems for higher operating pressures. It also specifies process and quality control of the production of these pipes. It is expected that the final TS 18226 will be issued in 2006.

Besides this international specification, DVGW, Germany, has issued a specification in 2004: DVGW VP 642 ( ref. 7 ). This specification is more or less in line with the draft ISO specification but is limited to a maximum operating pressure of 42 bar, and for the “light” aramid-based system to 25 bar.

## 4.2. Safety and risk analysis

Before applying RTP pipelines in gas networks a safety or risk analysis should be made. In this respect a quality and safety comparison has been made between reinforced and steel pipes on the basis of probabilistic calculations.

With respect to quality and safety, reinforced thermoplastic pipes and steel pipes are almost similar and the admissible failure probabilities are not exceeded. However, there is a marked difference when it comes to pressure testing in field practice: in the case of steel pipes pressure tests are used to check both material strength and tightness, while when performed on RTP they can only provide information on the tightness of the system. In the latter case the testing pressure must be rather low, because of the time dependence of the material strength of RTP materials. In principle the tests show that the failure probabilities determined for both products are within an acceptable range. The tests also show that it is not possible to examine all safety and quality aspects by probabilistic calculations because either the data required for these calculations are not available or insufficient. However, a qualitative comparison can be made, which is given in table 3 below.

*Table 3 . Qualitative safety comparison between RTP and steel systems*

Parameter	Steel	RTP
Cathodic protection monitoring	+	-
Susceptible against chemical attack	-	-
Susceptible against corrosion	-	+
Stresses cause swelling of material	-	+
Pressure test	+	-
Joint testing	+	-
Permeation	+	-

*Legend: + no or favourable impact on quality and safety level  
- no or negative impact on quality and safety level*

The results show that in terms of quality and safety, reinforced thermoplastic pipes are comparable to steel pipes, and the failure probabilities determined for both systems are within acceptable limits.

One of the advantages of plastic pipeline systems is that when an accident or incident is occurring the gas stream can be interrupted by squeezing of the pipe at operating pressure. For PE pipelines this is a well-proven practice. This squeezing technique can be applied as well to RTP pipes, at least at reduced pressures. Tests on 125 mm RTP pipes have shown that at pressures below 8 bar the gas stream can be stopped almost completely when squeezing the pipe ( see fig. 3 ). Squeezing, however, damages the pipe material. This means that the squeezed part has to be replaced or be repaired by a sleeve around the damaged part.



*Fig. 3. Squeezing of a 125 mm RTP "light" pipe*

### **4.3. Cost evaluation**

A cost comparison between traditional steel and RTP systems has been made for some “real” pipeline networks. The focus was on the investment costs, including material and installation costs. Attention was also given to a comparison of operating and maintenance costs. Cost analysis shows that the price of RTP pipes is higher than that of steel pipes. However, these higher material prices can be compensated by using more cost-effective installation methods such as ploughing.

The RTP system is a cost-effective option for situations where long lengths of pipes can be installed, like so-called ploughing techniques. In these situations the pipes can be installed in long lengths ( 200 to 300 meters ) from coils. In this case only a few joints have to be made. Presently these RTP systems are available in 4” (100 mm ) and 5” (125 mm).

## **5. CONCLUSIONS**

Based on the experience of the use of aramid-fibre reinforced thermoplastic pipeline systems for high pressure oil, gas and water transport systems, a “light” aramid-fibre reinforced PE system has been developed. These RTP systems are flexible and can be installed from coils. Jointing is done by a special electrofusion technique, based on the vast experience of electrofusion jointing in conventional PE pipeline systems. Extensive physical and mechanical tests ( to simulate field performance ), like long-term internal pressure tests and impact tests, showed that these RTP systems fulfill all the requirements for gas distribution systems intended for use up to at least 16 bar. These RTP systems are particularly attractive when installing long lengths of pipes using e.g. ploughing techniques. RTP pipes are delivered on coils and can be easily and quickly installed with few connections, thereby reducing construction costs. Compared to steel systems, considerable cost reductions, in the order of 25 %, can be obtained.

## **6. REFERENCES**

1. D. von Ameln and W.Wessing, “Aramid-reinforced Plastic Pipes, High-strength Pipes for Gas Transport” , Proc. Int. Gas Res.Conf., Vancouver, Canada (2004)
2. K.Grass, “Aramidbewehrte Kunststoffrohre im Hochdruckbereich, Verlegung einer Gasleitung als Pilotprojekt“ , GWF Gas-Erdgas 146, pp 146 – 150 (2005)
3. W.Wessing et al., „Novel PE Gas Supply System for a Maximum Operating Pressure of 16 bar” , Proc. Int. Gas Res.Conf., Vancouver, Canada (2004)

4. ISO/TS 18226 "Reinforced thermoplastic piping systems for gaseous fuels" (2005)
5. R.Tidball et al., "Third Party Damage Behaviour of Reinforced Thermoplastic Pipe (RTP)" , Symp. Natural Gas Technologies, Orlando, USA (2004)
6. R.Eckert, "Neuartige Verbindungstechnik fuer faserverstaerkte Kunststoffrohre in Hochdruckanwendungen" , 3R Int. 44, pp 266 – 268 (2005)
7. DVGW Technische Regel VP 642 (2004), „Faserverstaerkte PE-Rohre (RTP) und zugehoerige Verbinder fuer Gasleitungen mit Betriebsdruecken ueber 16 bar“

### **Acknowledgements**

We like to thank E-ON Ruhrgas, Gaz de France, gasNatural, Pipelife, Friatec, and DVGW for funding this research. The contributions of mrs. Grass (Thuega), mrs. Corral-Hernandez (Gaz de France), mr. Gueugnaut (Gaz de France), mr. Canet (gasNatural), and mr. Luehrsen (Veenker) to the discussions in the projectgroup are also greatly appreciated.