

# The High Tech, Human Touch Magazine

2014 Edition



## In vitro meat

Karin van Leersum  
Joris Luyt  
Wouter Versluijs  
Dimitrios Vlachos

## TwentePAM

Ryanne de Boer  
Ruud van Laar  
Peter Binipom Mpuan

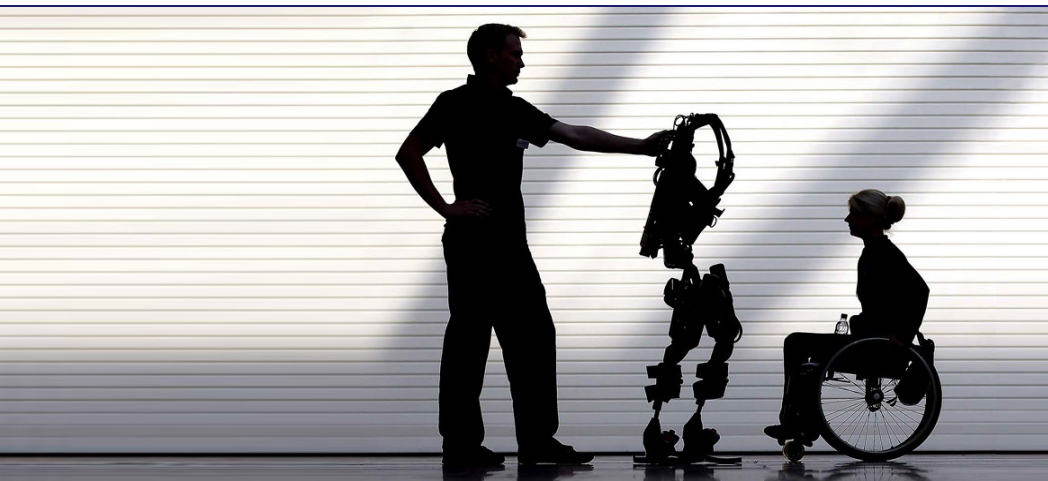
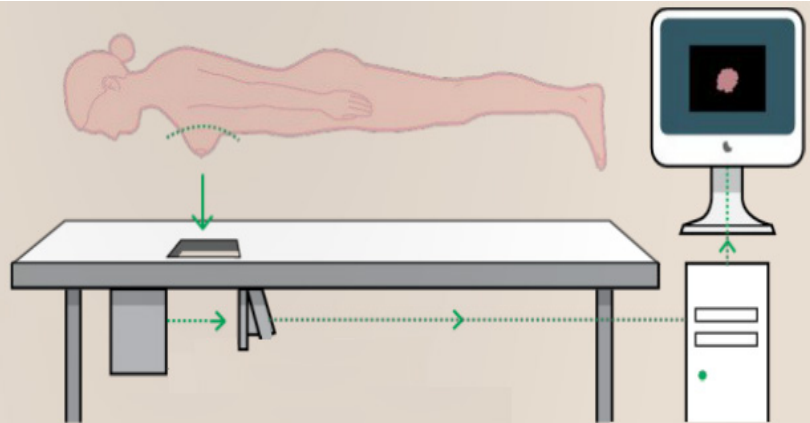

## Exoskeletons

Wouter van Dijk  
Pieter van den Bosch  
Savvas Kikidis  
Niels van der Vlugt

# Editorial

Dear reader of The High Tech, Human Touch Magazine 2014 Edition,

For the course Technolab in the master program Philosophy of Science, Technology, and Society, supervised by prof.dr.ir. M. Boon, we were assigned to write a magazine that covers three different research projects within the University of Twente. In the magazine, we examined the technological, social, and philosophical aspects of the research projects. Going through the magazine, we will take you along different technologies from outside the human body until cellular level. We can enhance the human body, enhance the way to detect illnesses in the human body, and enhance the human lifestyle. Do we really want to enhance the human being in all thinkable ways, or only enhance some aspects?

This magazine begins with a technology that is a result from cell research. Within cell research it is not only possible to generate human tissue, but it is also possible to produce animal tissues. The latter will give us the opportunity to create artificial meat, which is more animal friendly. It can be a fantastic solution for all kinds of problems, but a lot of challenges have to be overcome first. Insight in the technological and social challenges, and a philosophical perspective can be attained at pages 1 to 59. The authors of this part of the magazine are Karin van Leersum, Joris Luyt, Wouter Versluijs, and Dimitrios Vlachos.

To detect illnesses, and especially cancer, we need advanced techniques in order to improve diagnosis. Breast cancer is a severe and common form of cancer all over the world, and to improve the detection a new technique called Photoacoustic Mammography is developed at the University of Twente. In the magazine you can read about the technological aspects, social impact, and philosophical reflection of this technique at pages 61 to 106. The authors of this part of the magazine are Ryanne de Boer, Ruud van Laar, and Peter Binipom Mpuan.

To conclude, a technology to enhance the human body will be investigated. An exoskeleton is not only to improve the way human beings can move, but it can also be used as a treatment for illness. Exoskeletons can be used to help during the rehabilitation process, where patients using the device will be assisted during its movements. You can find the technical background of exoskeletons,

and also an account of the social impact, and a philosophical reflection at pages 107 to 142. The authors of this part of the magazine are Pieter van den Bosch, Wouter van Dijk, Savvas Kikidis, and Niels van der Vlugt.

These three different technologies, featuring all kinds of different aspects, have in common that they are all emerging and very promising according to researchers. We hope that in reading this magazine we will inform you about the topics and change your perspective on technology development and its social and philosophical implications, and let this issue of The High Tech, Human Touch Magazine 2014 Edition inspire you!

Editors of The High Tech, Human Touch Magazine 2014 Edition,

Ryanne de Boer, Pieter van den Bosch, Wouter van Dijk, Savvas Kikidis, Ruud van Laar, Karin van Leersum, Joris Luyt, Binipom Mpuan, Wouter Versluijs, Dimitrios Vlachos, and Niels van der Vlugt.

Enschede, April 2014

## Preface

The University of Twente profiles itself as a *High Tech, Human Touch* Research University. Its vision is high-tech solutions for the grand challenges of society. HTHT solutions are not technocratic – no, HTHT research aims at technologies that are valuable for society by anticipating successful implementation and suitable uses. Buzz-words are *Problem-solving, Science, Innovation, Valorization, Entrepreneurship, Multidisciplinarity, Questions, Research, Progress, Sustainability, and Solutions*. Yet, fleshing out such a *High Tech, Human Touch* profile is a challenge. Advertizing it is one thing, doing it is another. According to the HTHT slogan, students and researchers are challenged to look beyond the boundaries of their own field and establish links with other disciplines. But do we know how to work multidisciplinary? And do we know how to combine research, design and organization? Believing that behavioral and social science research must play a vital role in technological innovation does not necessarily mean that we understand how to do that. It appears that many of us do not even have a clear picture of what the gamma disciplines have to offer. We often lack insight in the kinds of problems that may emerge when ignoring the so-called soft side of technology and we do not have a clue of the kinds of questions that should be asked in a thorough HTHT approach. Conversely, researchers in the behavioral and social science often lack understanding of technological research and do not have a clear picture of how they may interact or contribute to technologies that supposedly stimulate change, renewal and progress in society.

The *HTHT Technolab Magazine* series aims at these audiences. It is written for those who are curious, and for those who are skeptical, and especially for those who would like to learn by means of examples about these unknown dimensions of HTHT research. This magazine has been produced by students in the *Philosophy of Science, Technology and Society* (PSTS) taking the course called *Technolab*. Each quire of this magazine has been written by a mixed group of students holding a bachelor degree in gamma, beta or alpha. They have chosen challenging technological developments with clear significance for society. The HTHT Technolab Magazine of 2013 covered a wide range of topics, such as *Smart grids, Blue energy, Human-brain interaction, Tissue regeneration, and Data storage*. This year, the students have chosen *Pammography, the Exo-skeleton, and In-vitro meat*.

The magazine firstly aims at illustrating how technological design and scientific research hang together. On the face of it, the advantages of a new technology seem pretty straight-forward, but at a closer look its development faces many challenges, which having to do with technological difficulties that emerge from external criteria such as costs, safety, user-friendliness, flexibility and so on and so forth. Pammography, for instance, is an innovative imaging technique for breast-cancer diagnosis. It has several advantages over the current mammography, but in order to be competitive the production and processing of data must become faster and cheaper. The Lopes exoskeleton is an apparatus for rehabilitation training of patients who have suffered a stroke. Its value is mitigating the physical workload of physiotherapists. Challenges in the technological development are that the apparatus must be easy to put on, light to wear and safe and flexible for different types of patients. In-vitro meat sounds as a great solution for environmental problems and animal suffering in bio-industry. However, currently, the growth-rate of animal cells is very low, whereas the costs of the growth-media still are very high. How these kinds of challenges incite research in the engineering sciences is explained in the magazine. Furthermore, it is explained why *technological validity* is not the only thing that counts in making a technological innovation happen. Here it becomes obvious that the role of the social sciences is not some kind of luxurious topping, but a vital part for successful technological innovation. Finally, each quire addresses philosophical and ethical issues related to these technological developments.

The PSTS students have done a great job in writing this magazine. They bring together many relevant aspects such that we learn to better understand the challenges of technological design, engineering sciences, social sciences and philosophy, and also, how this gives the full picture of technological innovations. For creating this magazine, the students have studied relevant scientific and professional literature in different fields and they have also interviewed researchers. In this manner, they have created three new examples of what multidisciplinary *High Tech*, *Human Touch* research might look like.

Mieke Boon,  
Enschede, April 21<sup>st</sup> 2014





# Contents

**04**

**Welcome and acknowledgements**

**06**

**The history of in vitro meat**  
From science fiction to scientific facts

**08**

**In vitro meat for dummies**  
A technical introduction to in vitro meat

**11**

**From petri to dish**  
Mark Post's first in vitro meat hamburger

**14**

**An introduction to the technological challenges for in vitro meat**

**16**

**A matter of character(istics)**  
The technology of mimicing meat

**20**

**Scale and cost**  
Two technological issues regarding the future of in vitro meat

**23**

**Cool meat**  
Is in vitro meat a fantastic solution for global warming?



**26**

**An introduction to the social challenges for in vitro meat**

**28**

**The meat colossus**  
Exploring the meat industry by making a social map

**32**

**Brave new meat**  
The marketing of in vitro meat

**35**

**World hunger**  
Food security and in vitro meat

**38**

**Vegetarian meat?**  
A vegetarian perspective on in vitro meat

**42**

**Holy meat**  
In vitro meat and religion

**44**

**An introduction to philosophical reflection on in vitro meat**

**46**

**A moral analysis**  
Putting in vitro meat to trial

**50**

**What are what we eat**  
Food or 'strange techno-meat'?

**54**

**Liberating the livestock**  
In vitro meat and the relation between mankind and the animal

**56**

**The technological fix**  
Heidegger's deontological argument against in vitro meat

# Welcome

Ready for juicy stuff, good taste, clear structure and something to chew on? Welcome to this magazine on in vitro meat! Its history, future and especially the challenges will make for an exciting trip through technological stories, social analyses and philosophical articles. Not only will you gain basic knowledge on all these aspects by reading this magazine, you will also get insight into the many challenges the 'new meat' presents on all kinds of areas.

Why in vitro meat? The motivation to pursue the in vitro meat technology really lies in the problem of our meat production. With growing population and wealth, meat consumption has grown, and will grow, exponentially. In the near future, this trend can simply not continue. We don't have the space and resources to maintain livestock that size, and on top of that there are huge environmental concerns and persistent moral debates that problematize our meat industry. In comes in vitro meat.

Before we let you plunge into the deep to explore all of in vitro meat's facets: the idea of in vitro meat is simply that animal cells are grown outside of the animal, into proper meat. Thus without the need to kill animals, meat could be produced that is almost indistinguishable from the meat as we know it now. In vitro meat has been produced in a very limited amount for very high costs, but the future is quite promising for it as a technology and there are many reasons to be happy about this: animal suffering would decline, mass production could be attained for low costs, it is less polluting and nature suffers less and in vitro meat is even seen as a possible solution to world hunger. At first glance, in vitro meat seems to offer a solution to many concerns that trouble 'normal' meat production.

There are however many challenges to be overcome before these promises might become reality. In this magazine we will explore these different challenges and take a critical view on the promises in vitro meat has. The magazine is divided into four parts: a general introduction into the subject, a section that goes more in-depth into the technology with an analysis of (future) challenges in this area, an exploration of the social issues concerned with in vitro meat and a philosophical part to reflect on the introduction of in vitro meat in a broad sense.

The idea of growing a few animal cells into a real hamburger might sound technically overwhelming, and we are not saying it is not, but to give an insight into the most important technological parts, the magazine starts by investigating the technology behind it. The technology is not yet fully there, considering the project in which the hamburger produced last year cost several hundreds of thousand dollars. The challenges that exist in this technological field are therefore discussed after the technological introduction.

However, even if the many technological challenges are properly solved, it is still a long, long way from a laboratory proof of concept to a marketable product. Social challenges are presented in the second part of the magazine: the industry, the public, institutions, how will they react? Also will the important question be discussed whether in vitro meat could be a world saver by providing food for everyone, as many hope for.

In vitro meat is a technology that goes much further than just providing us food: the meaning of animals, food and nature could seriously change. In the last philosophical part of the magazine these issues are reflected upon to get a broader idea of how far the influence of in vitro meat could stretch. We hope you have been appetized by the prospect of getting coverage of all these different areas of importance for in vitro meat and will not hold you any longer from getting into it. Enjoy!

# Acknowledgements

For this magazine, numerous sources were used, from articles from specialized papers on in vitro meat from Wageningen and Utrecht, to more general articles from newspapers and Nature, to e-mail exchange with farmer relatives. Making the magazine as it is now would however not been possible without the interviews that were conducted with the scientists themselves and the survey that was conducted:



Prof. Dr. van der Weele, Wageningen University, leading expert on the ethical issues concerning in vitro meat and highly involved in in vitro meat projects

Prof. Dr. Haagsman, Utrecht University, technical expert of in vitro meat and one of the main Dutch scientists on the subject, started the in vitro meat project in 2005



Dr. Galetzka, University of Twente, expert on marketing communication and consumer psychology, has been involved with meat substitutes

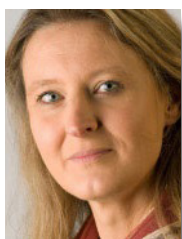

Prof. Dr. te Molder, Wageningen University and University of Twente, science communication expert and involved with a research on audience reaction of in vitro meat



A survey set up for this magazine and filled in by 124 respondents, focused on the consumer acceptance of in vitro meat, but also asking more broader question concerning vegetarianism amongst others



# The history of in vitro meat

## From science fiction to scientific facts

---

Producing meat without killing animals has for a long time been a dazzling idea. It is time to distinguish fact from fiction and go back to the roots of in vitro meat.

---

Stories of unlimited meat grown out of animal cells have been around for more than a century; from a story in the 19th century of Martians bringing artificial meat to the Earth (Laßwitz, 1897), to more recent episodes of Star Trek (Chakoteya, 1966). But what exactly are the facts? Winston Churchill predicted in 1932 that it would be possible to grow chicken meat more efficiently: "We shall escape the absurdity of growing a whole chicken in order to eat the breast or wing, by growing these parts separately under a suitable medium" (Weele & Driessen, p.649). It would however still take a long time before the first signs of actual artificial meat could be seen. First of all, the whole field of tissue engineering needed to be established. This development slowly started 1985, and in 1988 the first official scientific meeting within the field of tissue engineering was held (Viola, Lal & Grad, 2013). In 2005 the first article on in-vitro meat was published in an issue of the journal Tissue Engineering (Ternes, 2005).

Before, this article however, there had already been developments towards in-vitro meat. In 1950, Wim van Eelen already first had the idea to 'grow' meat. It was in 1999 that he actually applied for a patent (Resources, 2011). NASA first started experimenting with in-vitro meat in 2001 (The Australian, 2007). Special reason

for their interest was that growing meat cells artificially might develop into a way to provide food for astronauts. In 2002 the first piece of in-vitro grown meat was eaten: goldfish cells had been grown (Jones, 2010). Growing in-vitro meat was from then picked up by different institutions, which in 2003 led for instance to the project 'Disembodies Cuisine' where muscle tissue of a frog was grown to serve guests at a showcase dinner, while the frog was (allegedly) still alive (Catts & Zurr, 2004)

In 2004 an important step was made by Jason Matheny starting the project 'New Harvest' which concentrated on in-vitro meat as a future promise (Weele & Driessen, 2013). This project was initially started by a four year research carried out in the Netherlands. It is from this project that the Netherlands started to be a pioneer in the field of artificial meat and the Dutch government has been sponsoring a large project for more than four million dollar (Weele & Driessen, 2013; The Australian, 2007). In 2009 it was announced that the project led by Mark Post in Eindhoven University had led to the accomplishment to grow in-vitro meat by using cells from a live pig (Edwards, 2009).

August 2013 saw the first 'public trial' of in-vitro meat (BBC, 2013). It again came from the Dutch project. By growing meat strips and combining them, a first in-vitro 'hamburger' was made and tasted by chefs and critics. Interesting is that of the 325,000 dollar this specific two-year project had cost, 250,000 dollar had been paid by one of Google's founders, Sergey Brin (Fountain, 2013).

Interesting in this history are the many parties that were getting involved in in-vitro meat as it progressed. What started by wild ideas and predictions and only got NASA involved in the first place, was later picked up by many researchers as a serious future promise. And in 2009 Time Magazine announced it as to be one of the year's 50 best inventions (Kluger, 2009). Research institutes, artists and universities starting on researching this issue, from both technical and more social or ethical perspectives. Interesting is for instance that the animal rights organization PETA has since 2008 been offering a prize of one million to the first laboratory that proves to be able to produce commercially viable in-vitro chicken meat (PETA, 2014). The meat should both completely resemble real chicken and be able to be sold in at least ten US states. The contest has recently been extended until March 4, 2014, not accidentally the 85th anniversary of United States President Herbert Hoover's inauguration, who promised a "chicken in every pot".

Author: Wouter Versluijs

## Sources

BBC. (2013, August 5). World's first lab-grown burger is eaten in London. Retrieved January 1, 2014, from BBC: <http://www.bbc.co.uk/news/science-environment-23576143>

Catts, O., & Zurr, I. (2004, Winter). Ingestion / Disembodied Cuisine. Cabinet Magazine

Chakoteya. (1966). Star Trek Episode Charlie X: Transcript. Retrieved January 10, 2013, from Chakoteya.net: <http://www.chakoteya.net/startrek/8.htm>

Edwards, L. (2009, December 1). Pork meat grown in the laboratory. Retrieved January 1, 2014, from Phys.org: <http://phys.org/news178869104.html>

Fountain, H. (2013, August 5). A Lab-Grown Burger Gets a Taste Test. Retrieved January 1, 2014, from The New York Times: [http://www.nytimes.com/2013/08/06/science/a-lab-grown-burger-gets-a-taste-test.html?\\_r=2&](http://www.nytimes.com/2013/08/06/science/a-lab-grown-burger-gets-a-taste-test.html?_r=2&)

Jones, N. (2010). A taste of things to come? Nature, 468, (7325), 752-753.

Kluger, J. (2009, November 12). The 50 Best Inventions of 2009. Retrieved January 1, 2014, from Time: <http://content.time.com/time/specials/packages/>

article/0,28804,1934027\_1934003\_1933945,00.html

Laßwitz, K. (1897). Auf Zwei Planeten. Retrieved January 10, 2013, from Project Gutenberg: <http://gutenberg.spiegel.de/buch/3118/1>

PETA. (2014). PETA Offers \$1 Million Reward to First Person to Make 'Test Tube' Meat. Retrieved January 1, 2014, from PETA: <http://www.peta.org/features/vitro-meat-contest/>

Resource. (2011, February 10). Making Meat. Resource Magazine

Ternes, E. (2005, July 6). Paper Says Edible Meat Can be Grown in a Lab on Industrial Scale. Retrieved January 10, 2013, from UMD Newsdesk: <http://www.newsdesk.umd.edu/scitech/release.cfm?ArticleID=1098>

The Australian. (2007, January 20). Test-tube meat science's next leap. Retrieved January 1, 2014, from The Australian: <http://www.theaustralian.com.au/news/health-science/test-tube-meat-sciences-next-leap/story-e6frg8y6-1111112859219>

Viola, J., Lal, B., & Grad, O. (2013). The Emergence of Tissue Engineering as a Research Field. Arlington, VA: The National Science Foundation.

Van der Weele, C. & Driessen, C. (2013). Emerging Profiles for Cultured Meat; Ethics through and as Design. Animals, 647-662.

# In vitro meat for dummies

## A technical introduction to in vitro meat

---

Artificial, in vitro, or cultured might have an unnatural ring to it. But is it really that unnatural? Let's explore the technical basics.

---

For something which sounds so unnatural and modified as artificial meat, or in vitro meat, which is the preferred term in scientific research, it is in fact not quite that unnatural. Scientists essentially try to grow normal meat, only not in an animal. The main difference is that in vitro meat is in vitro, grown outside the body, as opposed to in vivo, grown inside a live animal. As a result of this difference, some other differences arise, for example the 'soil' in which the meat is grown. However, because the cultivation of in vitro meat is so analogous to cultivation of meat in vivo (i.e. how we raise livestock for meat), it is relatively easy to understand what scientists, working on in vitro meat research, are trying to accomplish. To grasp the general idea of what they're doing, you don't have to be a cell biologist.

Scientists working on in vitro meat research are usually working in the field of tissue engineering, and specifically on muscle tissue. This field of biology examines the cells and processes associated with muscle tissue. They start with a few cells and try to find the conditions under which it will grow into a large amount of cells, and under what conditions it will form a tissue, the superstructure of these grown cells. Researchers on in vitro meat have, almost without exception, chosen skeletal muscle tissue for their in vitro

meat research. Skeletal muscle is one of three types of muscle tissues, and the most intuitive: the muscles which we can control, in our arms, our feet, our back, are made primarily out of skeletal muscle tissue. A filet mignon steak is (mostly) skeletal muscle tissue from a cow. So, this tissue type is our prime candidate for producing in vitro meat, and therefore it is this tissue that all research in the field has focused on.

To grow these cells into some piece of in vitro meat, so far two methods have been demonstrated. Morris Benjaminson was the first to tackle the problem in 1998. He and his research team grew goldfish fillets as part of a project by NASA investigating the possibilities of growing food in space. The method they used was quite simple: they cut off large chunks of goldfish, cleaned them and put them in a growth serum. This growth serum is bovine fetal blood, blood from unborn calves, but luckily animal-friendly alternatives are in the making (Edelman, 2005). After some time, these fillets grew slightly (14-17%, depending on how you calculate). They then fried them in olive oil with lemon, garlic and pepper, and colleagues reported that this artificially grown fish looked edible; however they weren't allowed to eat it by the US Food and Drug Administration (Bartholet, 2011). It was a proof of concept, but future

## FROM PIG TO PLATE

Researchers are adapting tissue engineering techniques to grow edible meat, *in vitro*.

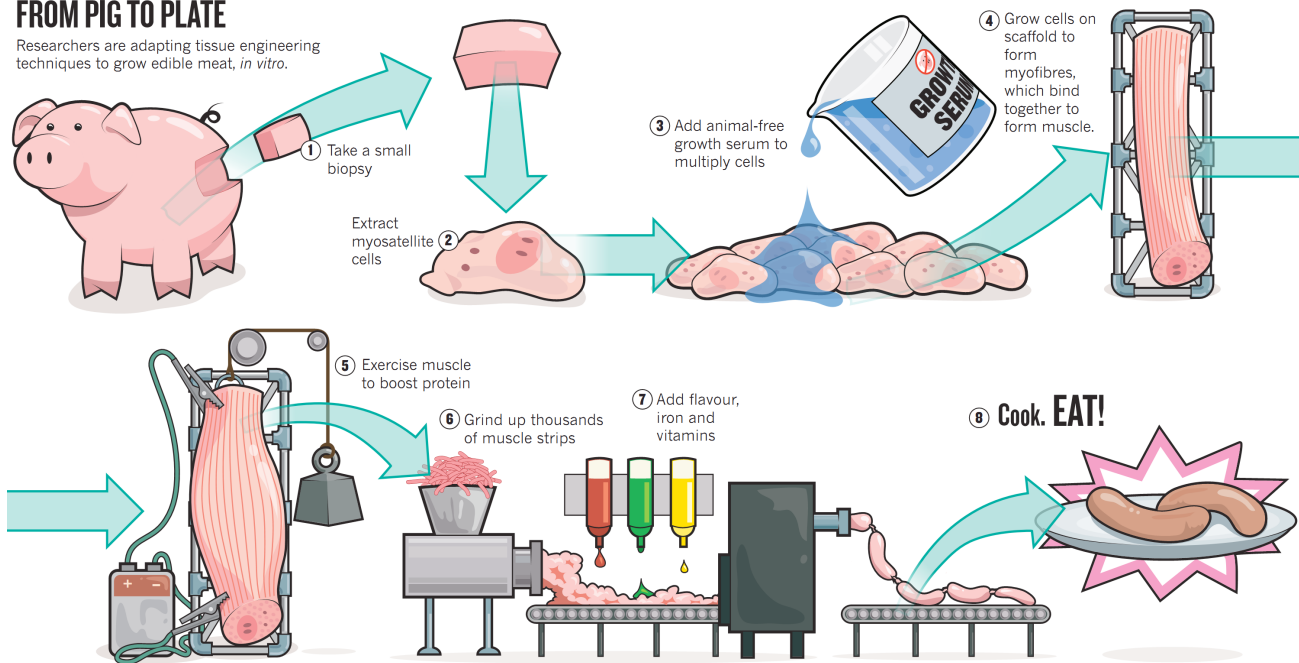

# 09

scientists went another, more fundamental way. The scientists of the future were Dutch. Wim van Eelen, known as the pioneer of in vitro meat and holder of the world's first in vitro meat patent, together with Henk Haagsman (and his team) received a grant from the Dutch government to pursue in vitro meat research. Unlike Benjaminson, these scientists followed a more fundamental approach, which is 'standard' today, as far as we can speak of standard with this emerging technology. Haagsman set out to experiment with porcine in vitro meat ('pork') by starting at a fundamental biological level: the cell. Some of his achievements during his years of research, while the grant lasted, are shown, simplified of course, in Figure 1. By means of a biopsy it is possible to retrieve potent cells from an animal, in this case a pig. Among these are pre-cursor cells (for muscle cells), called the myosatellite cells. When working with muscle stem cells, and biological tissue researchers often do, some extra work needs to be done to have the stem cells differentiate into myosatellite cells, but other than that the process is the same. Then, under the right conditions, these cells will form muscle tissue: the cells need to grow, and they need a medium where they can grow in, which

Figure 1. A simplified scheme of the in vitro meat process, from stem cell biopsy to sausage. *Nicola Jones (2010)*.

is the first condition. Furthermore, myosatellite cells must be activated so they become myoblast cells, and in turn these myoblast cells must be encouraged to form multi-nucleated fibers, i.e. they need to merge themselves and also align in a particular way, as actual muscles are enormous arrays of myofibers (or myotubes), fused myoblast cells (and thus with multiple cell nuclei). Van Eelen's patent includes a way to get myoblasts to form myofibers, namely the (specific) use of a scaffold on which the myoblasts 'stretch' and form myofibers naturally. To simplify the entire process somewhat: from a biopsy you take cells that can form muscle cells (for example stem cells or precursor cells). Once they start growing, they clump together and form skeletal muscle tissue, which is the main component of meat. This process and the resulting tissue is exactly the same as in a living animal, it is just outside of an animal. For this reason, in vitro meat is considered safe by scientists working with it.

### Muscle and embryonic stem cells

There are two types of stem cells used in in vitro meat research, muscle stem cells and embryonic stem cells. The first are easier to differentiate into muscle cells, they only need some proteins to start the myogenesis process (the formation process of muscle tissue is called myogenesis), but has a distinct disadvantage: at some point muscle stem cells will no longer grow, they've reached their limit. Embryonic stem cells do not have this problem, which means that an individual culture of embryonic stem cells can potentially produce endless amounts of muscle tissue. However, such an embryonic stem cell line has not been found yet for cows, chickens or pigs, only for monkeys, humans, mice and rats. Finding an embryonic stem cell line for traditional livestock is an important technical challenge, and this is why Henk Haagsman has focused his current in vitro meat research on this (Haagsman, 2014).

## In vitro meat and safety

An issue that often comes up regarding in vitro meat is safety. When one thinks of food safety concerns, genetically modified foods come to mind, and an analogy with in vitro meat is often made by a technological layman. However, that analogy is quite simply wrong. There is no modification whatsoever involved: the tissue that is produced in vitro is technically the same as the tissue in an animal. This is why Mark Post had no hesitance in tasting his own produced in vitro burger (see article page 11), and Henk Haagsman laughed when asked about whether or not he would eat it. "Of course I would, why not?" he replied. Cor van der Weele was also asked about the safety of in vitro meat, and replied: "For in vitro meat I'm really not so worried; the dangers are hard to imagine. It is not genetically modified or modified in any other way. The only thing that could happen is an infection of some sort. That is something that can also happen in live animals of course. I would definitely try in vitro meat when it is on the market"

So, in vitro meat is as safe as normal meat, if not safer: future factories that produce in vitro meat (see article page 20 ) can, in principle, be completely sterile. That means no possibility of infections, and no added substances like antibiotics which can often be found in normal meat.

Haagsman perhaps understates what he accomplished during this pioneering research by mentioning that most of his techniques for developing the in vitro meat methods were directly derived from very similar work in ordinary animal cell biology, which he, as a professor in the faculty of veterinary medicine at the University of Utrecht, was very experienced with. However, it remains that what Haagsman started, is still rolling, in general terms, today.

When we have these myofibers, we still have some steps to go before we can make a tasty sausage out of the pork myofibers. The next step is to exercise the meat so that it becomes bulky, this is often done by electrical stimulation, but research has shown that this kind of exercise is inferior to in vivo stimulation of the muscle fibers (Edelman 2005), and this is perhaps because actual in vivo stimulation is done not electrically, but chemically (Mark Post, 2013). Beyond this step, which itself is only in the earliest phases, there has been very little actual research. In fact, only Mark Post has completed an actual piece of in vitro meat, while other researchers are working on more fundamental issues, frustrating the pioneer Wim van Eelen, who is eager to see in vitro meat commercialized during his lifetime (Bartholet, 2011).

Author: Joris Luyt

## Sources

Bartholet, Jeffrey (2011). Inside the meat lab. *Scientific American*, Vol. 304 Issue, 64-69.

Edelman, P.D., McFarland, D.C., Mironiv, V.A., Matheny, J.G. (2005). In Vitro-Cultured Meat Production. *Tissue Engineering* 659-662

Haagsman, Henk. (2014, February 14) Interview on technological aspects of in vitro meat.

New Scientist. (2002). Fish fillets grow in tank. Retrieved March 6 2014 from New Scientist: <http://www.newscientist.com/article/dn2066-fish-fillets-grow-in-tank.html>

Jones, N. (2010). A taste of things to come? *Nature*, 468, (7325), 752-753.

Post, Mark. (2013). Meet the new meat: Mark Post at TEDxHaarlem. Retrieved March 6 2014 from TEDx Talks: <https://www.youtube.com/watch?v=ZExbQ8dkJvc>

The Scientist. (2007). Meat, in vitro? Retrieved March 6 2014 from TheScientist: <http://www.the-scientist.com/?articles.view/articleNo/25358/title/Meat--in-vitro/>



# From petri to dish

## Mark Post's first in vitro meat hamburger

---

When you walk into a supermarket, trying to decide what you will have for dinner, chances are you will end up in front of the meat section.

---

Perhaps a steak would be nice for tonight. Now, imagine it is the near future, and in this future the meat section contains two types of steak. The first is a cheap, in vitro meat, which is low in fat. The other is a steak, prone to disease, more expensive because it is much more demanding for the environment, and on top of that it has a label saying "Caution! Animals have suffered for this product". This is the future Mark Post imagines, and we have reason to pay close attention to him.

Mark Post is a professor of vascular physiology and the chair of physiology at the Maastricht University. There, he works mostly on vascular biology, but in the last decade he has picked up another, related field: in-vitro meat. Mark Post sees serious problems with our current meat production: most importantly, cattle, and mainly cows, produce huge amounts of methane, a greenhouse gas, and it is approximated that 18% of all greenhouse gas emissions originate from livestock (Cultured Beef, 2013). It is this that leads Mark Post to say: "A vegetarian with a hummer is actually better for the environment than a meat-eater with a bicycle."(Mark Post, 2013), and this illustrates the seriousness of the problem. But there are more environmental issues than just greenhouse gasses, for example the 1500 liters of fresh water required for one kilogram of beef,

or the decreasing biodiversity when our livestock becomes a larger and larger part of the world's total animal count (FAO, 2006). If the world's current population growth continues like it does now, and our meat appetite doesn't decline, there is simply no way the earth can provide for us if we don't make drastic changes in the way we eat meat, so says Mark Post. While he is no expert on food sustainability or greenhouse emission, he doesn't need to be to address these problems in a technological manner: his expertise and his



Figure 2. Mark Post shows the first in vitro meat patty. *David Parry EPA*

---

Figure 3. To produce the in vitro meat hamburger, around 60 billion cells are needed. The actual cell cultures are white or grayish, the tasty red color is accomplished by a combination of red beet juice and saffron, which, according to Hanni Rützler, did not affect the taste. *David Parry EPA*



perseverance in cell biology made the creation of the world's first in vitro hamburger possible. The project wherein the hamburger was created and presented was funded partially by Google's Sergey Brin, who donated a quarter of a million US dollars to the project since he shared Post's environmental sustainability concerns, but also because he was very uncomfortable with how badly animals were treated in the meat industry of today (The Guardian, 2013b), which is yet another problem.

Mark Post, together with two food technicians, worked in the lab for several years, although not full-time, to come up with the skillset and technology that is required to produce a large number of myotubes. When they finally could, they grew about twenty thousand of these myotubes over the course of three months and when they matured, they were put together to form a hamburger patty. This hamburger was a bit pale, so they colored it using some beet juice and saffron, added some breadcrumbs and a binding agent (egg powder) to make it stick together nicely, but nothing else was added. The hamburger was cooked by a renowned chef Richard McGeown and eaten by Hanni Rützler, food scientist, journalist Josh Schonwald, who recently published a book on future food, and of course by Mark Post himself. They described the hamburger as close to meat, but not yet there. The hamburger had a good bite and the 'mouth feel' was the same as normal meat, unlike vegetable hamburgers. The hamburger also browned up nicely, and had quite an intense taste, but it was not as juicy as a normal hamburger, mostly due to the lack of fat. Hanni Rützler said she considered it meat, but it was also definitely different than a regular hamburger, and Josh Schonwald commented it was somewhere between a McDonalds hamburger and a BOCA burger, an American brand of vegetable burgers. To be fair, Josh Schonwald added that he cannot recall the last time he ate a hamburger without condiments and salt and pepper. Mark Post concluded that

this hamburger satisfied his expectations, as this was mostly a proof of concept, and he did not expect the burger to taste like a regular one because there was not a single gram of fat in it. Producing fat is possible, he says, and it has been done for medical purposes, but the differentiation factor for lipids (fat), what makes the early cells develop into a particular cell type (in this case fat), is not suitable for the food industry, so he is working on finding a way around that.

While it took several years to produce the hamburger, Mark Post insists that what he has done was nothing special, except grow enough myofibers to form an actual hamburger (The Guardian, 2013c). While for example Henk Haagsman focused on pork, beef is perhaps a better candidate since sustainability problems with cows are the greatest out of the popular meats (beef, pork, chicken), and since Mark Post wants to address environmental problems with his cultured meat, beef was the logical choice for him. He extracted muscle satellite cells from a cow in a harmless procedure, a simple biopsy from the shoulder. These satellite cells are stem cells that can only develop into muscle cells, and, after isolating the stem cells from biopsy, they were differentiated into muscle cells. Finally, these cells were put into a petri dish with a culture medium to grow and let to self-exercise by putting a small cylinder in the petri dish around which the muscle fibers flexed themselves. The culture medium used was still bovine serum blood, Mark Post admitted, but he looked at ten different medium substitutes and found that one of them was suitable for beef, which was great news in terms of animal welfare. When the muscle cells proliferated enough, and became a bit more bulky after exercising, they were harvested, until there were around twenty thousand of them, and at that point they were put together into a hamburger as described earlier.

For the future, there are many challenges, but Mark Post seems to focus on increasing

efficiency of this particular process first. Minced meat, out of which hamburgers are made, takes up approximately half of the world's meat consumption, so if he only manages to perfect this, he would already be halfway there. With current technology and efficiency, he claims that he can probably achieve prices as low as \$70/kg, which is of course still a factor of ten above today's normal meat prices. However, anticipating the increase in normal meat prices in the near future, for example caused by shortage when the 3rd world middle class will start eating meat, and his confidence that he will be able to improve the efficiency of the cultured beef production, his in vitro minced meat has a bright future ahead of it.

Author: Joris Luyt

## Sources

Cultured Beef. (2013, August 5). The Event. Retrieved February 22 2014 from Cultured Beef: <http://culturedbeef.net/event/>

Food and Agriculture Organization of the United Nations (FAO) (2006). Livestock's Long Shadow: environmental issues and options. Rome.

Post, Mark (2011). Meet the new meat. If Conference 2011. Retrieved February 21 2014 from iq2if: <https://www.youtube.com/watch?v=PYQWR3aC5g8>

Post, Mark. (2013). Meet the new meat: Mark Post at TEDxHaarlem. Retrieved March 6 2014 from TEDx Talks: <https://www.youtube.com/watch?v=ZExbQ8dkJvc>

The Guardian. (2013a, August 5). First lab-grown hamburgers gets full marks for 'mouth feel'. Retrieved February 22 2014 from The Guardian: <http://www.theguardian.com/science/2013/aug/05/world-first-synthetic-hamburger-mouth-feel>

The Guardian. (2013b, August 5). Google's Sergey Brin bankrolled world's first synthetic beef hamburger. Retrieved February 22 2014 from The Guardian: <http://www.theguardian.com/science/2013/aug/05/google-sergey-brin-synthetic-beef-hamburger>

The Guardian. (2013c, August 6). Can synthetic beef satisfy the world's growing hunger for meat? Retrieved February 21 2014 from The Guardian: <https://www.youtube.com/watch?v=K9mG1ZCoxUQ>

# An introduction to the technological challenges for in vitro meat

In vitro meat is a promising method with effects varying from local to global scale. The road though to its final establishment and acceptance is not free of bumps. In this article we will examine the technical challenges that in vitro meat is facing now and the ones expected in future.

The most important problem at the moment is the choice of stem cells. Henk Haagsman mentioned this as the prime challenge: "First is the choice of the right stem cell. What you ultimately want is to use a populace of stem cells that you can use for a very long time. So you make once enough cells and that every time, like a baker does to make bread, you have a kind of cell population you can return to. From there you make enough products, then you go back to this population so you can make more products" (Haagsman, 2014).

No matter how important that is, there are more challenges. Researchers are facing the task to achieve a taste (exactly) similar to natural meat, and this is difficult. The reason is that what consumers consider as typical meat taste is the result of several different components. (Claeys et al., 2004; Mottram, 1998). Artificial meat flavours do exist and are currently being used in meat replacements. Artificially adapting the taste of cultured meat would be more practical in the process of in vitro meat production, since there

are components that affect flavour which are still undetermined (Toldra & Flores, 2004).

Researchers generally believe that if the problem of taste is resolved, texture will be the next obstacle. The current inability to grow fibroblasts for the production of connective tissue in a 3D matrix lies on the fact that cells larger than 0.5 mm from a nutrient supply will die after a significant period of time. At the moment skeletal muscle grown to approximately 1.5 cm in length and 0.5 cm in width can be cultured (Gawlitta et al., 2008). These sizes might be appropriate for cases where a small quantity of meat is needed but the production of a tasty, juicy and big steak demands larger tissue sizes. Up-scaling of the cell and tissue culturing processes is therefore necessary and should be realized by co-culture with different type of cells.

Another rather psychological factor, but also a technical challenge, will be the ability of in vitro meat to mimic the colour of meat. As mentioned earlier myoglobin is a component in meat and responsible for the red colour (Miller, 1994), and also expressed by skeletal muscle cells in culture (Ordway & Garry, 2004). One way to achieve that is by means of artificial colouring, like in the case of artificial flavourings mentioned above.

One should not forget that meat has some important nutrients that everyone, vegetarian or not, admits that are important in our diet, and meat is the most common source. If actual skeletal muscle tissue will be engineered, scientists believe that important nutritional components (for example amino acids) will be present (Reig & Toldra', 1998). In addition, by tuning the substrates used for cultured cell metabolism (for instance using polyunsaturated fatty acids), we theoretically can affect the biochemical composition of muscle cells to make the product healthier (Jimenez-Colmenero, 2007).

A determining factor for the acceptance and establishment of artificial meat is the price per tone of the final product. But this is a combination of such a large variety of factors that can be proven to be even more complex than the previous challenges. Growth media involves 90% of the material costs of lab-grown meat (Jones, 2010). Its current price is at 7000-8000€/ton. According to a 2008 European study, cultured meat could become competitive to beef meat (3500€ per ton) only if the price of the growth medium is reduced by a factor of 10 (eXmoor, 2008).

Muscles that originate from the bundling of several myofibres in the lab are very weak and without texture. To stimulate protein production, which will make the muscle stronger, electrical stimulation is needed. At the moment, that application of energy is rather inefficient which would lead to huge costs if the process expands to industrial scale.

In order to scale up in vitro meat production, larger bioreactors will need to be developed. Vladimir Mironov estimates that a facility for the commercial production of in vitro meat would require a five-storey building of that type of reactors, which accounts to a huge investment (Jones, 2010). Moreover, to make the whole process less expensive and the product affordable for the average consumer, researchers need to develop a more efficient overall process.

The disconnection from living animals in artificial meat should also be accompanied by the development of synthetic culture media that will make the whole process completely independent of animal serum. Henk Haagsman notes: "The stem cells need to have a good medium and you need to make a medium which has nutrients that are cheap and are not from animal origin. So you need plant materials or materials from microbes that you can use to make enough nutrients". However there are already some solutions: "There are several serum-free media to culture stem cells but we are still not very well advanced. It's quite difficult but for other cells they are cultured without serum" (Haagsman, 2014).

An important advantage of in vitro meat is the promise of a product guaranteed to be free of any kind of disease; especially after the rather recent

global pandemic of diseases whose origins are found in the meat industry. That would require absolute sterility of the culture and all spaces used for production, thorough quality control of mammalian cell/tissue and the controlled breeding of stem cell from donor animals. Cor van der Weele said about pandemics at farms: "So far the idea is that in the case of in vitro meat it is much easier to detect, check and control any possible infections. Perhaps you should throw away a whole production line because it has been infected with a bacterium, but then you do not have to destroy animals or whatever. You just have to destroy some tissue or some cells" (Weele, 2014)

As you can notice there are several challenges and most of them have to be overcome before in vitro meat can be introduced into the market. In the next articles of the technological part of this magazine, you can read about the challenges round the taste and the structure at page 16, and the problems round scale and cost will be discussed at page 20.

## Sources

Claeys, E. et al. (2004). Quantification of fresh meat peptides by SDS-PAGE in relation to ageing time and taste intensity. *Meat Science*. Vol. 67; pp. 281-288.

eXmoor pharma concepts. (2008). The in vitro meat consortium preliminary economics study project 29071.

Haagsman, Henk. (2014, February 14) Interview on technological aspects of in vitro meat.

Jones, N. (2010). A taste of thing to come. *Nature*. Vol. 468; pp. 752-753.

Miller, R. K. (1994). Quality characteristics. In D. M. Kinsman, A. W. Kotula, & B. C. Breideman (Eds.), *Muscle foods*, 296-332. New York: Chapman & Hall.

Mottram, D. S. (1998). Flavour formation in meat and meat products: a review. *Food Chemistry*. Vol. 62; pp. 415-424.

Ordway, G. A., & Garry, D. J. (2004). Myoglobin: an essential hemoprotein in striated muscle. *Journal of Experimental Biology*, 207, 3441-3446.

Toldra', F., & Flores, M. (2004). Analysis of meat quality. In L. M. L. Nollet (Ed.), *Handbook of food analysis* (pp. 1961e1977). CRC Press.

Van der Weele, Cor. (2014, February 27). Interview about the ethical aspects around in vitro meat.

# A matter of character(istics)

## The technology of mimicing meat

---

What is it that makes meat so attractive to consumers? Taste? Texture? Nutritional value? The distinctive color? Actually it is all of the above.

---

It is a fact that meat consumption nowadays, especially in developed countries, has increased compared to the past and has led to overconsumption. A staggering 9 billion land animals (and 100 billion marine animals) are killed each year only in USA to fulfill the local demands (PETA, 2013). Figure 4 shows the history of global meat consumption since 1960 (Humane Society, 2013).

But what is it that makes meat so attractive to consumers? Is it the taste? Maybe texture? What about its nutritional value? Or could be the distinctive color? Actually it is all of the above. For a new meat substitute to be widely approved and adopted, it needs to exactly mimic or even better, recreate conventional meat in all of its physical sensations, such as visual appearance, texture and of course, taste (Bredahl et al., 1998; Verbeke et al., 2010). In addition there are some valuable nutrients that can only be found in meat. We will examine the progress and future potential towards resembling the mentioned characteristics of livestock meat.

### Taste

In the presentation of the first lab-grown burger in London in 2013 two food critics, namely Hanni Ruetzler and Josh Schonwald, were appointed to

taste it. One replied that it was close to meat, but not that juicy and the other said it tasted almost like a real burger (BBC, 2013). That was a big improvement compared to the only person Mark Post knew who tried in vitro meat before that. It was a Russian TV journalist who had visited his lab to film his research in 2010. "He just took it with tweezers out of the culture dish and stuffed it in his mouth before I could say anything," said Post. His reaction was "Chewy and tasteless!" (Jones, 2010). Meat taste is a combination of many different parameters. More than 1000 water soluble and fat derived components may make up the species and perhaps strain specific taste of meat (Claeys et al., 2004; Mottram, 1998). One should not ignore that, artificial flavoring agents, which are currently used in several meat products and replacements, can also enhance the taste of in vitro meat. And though pure in vitro meat has no fat content, myosatellite cells can also turn into fat, which would add to the taste. So it seems that its taste is not one of the major concerns since it can be manipulated in several ways towards the goal of resemblance to natural meat; or it can also lead to several variations of taste to satisfy various consumers' demands.

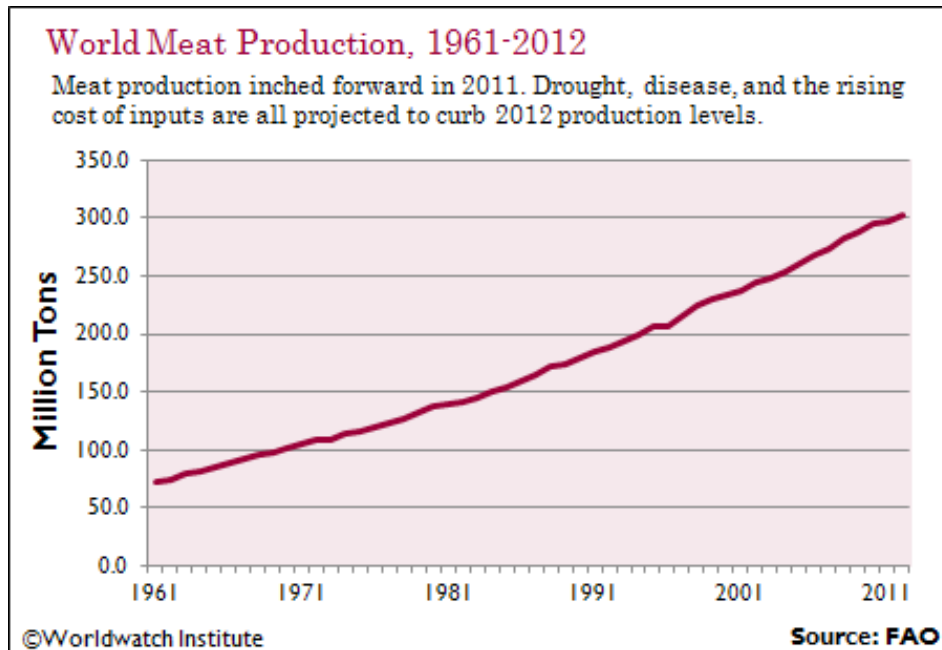

Figure 4. Global meat consumption in million tons. <http://www.worldwatch.org/disease-and-drought-curb-meat-production-and-consumption-0>

## Texture

Myofibrils, fat, and connective tissue are responsible for what we conceive as meat texture (Toldra & Flores, 2004) and that is why it is important to create functional muscle tissue that contain these myofibrils. The connective tissue and fat content should be realized by co-culture with different types of cells (Langelaan et al., 2010). To achieve the texture and consistency of conventional meat, factory-grown muscles need to exercise. This can be done either by mechanically stretching the cells or by applying electrical stimulation (Mattick & Allenby, 2012). The current samples are in the form of minced meat and others, such as steaks, will take at least five years to develop (Goodwin & Shoulders, 2013). Moreover, the fact that the form or structure of cultured meat does not resemble actual muscles is not a major problem, since there is already a big market for meat products without bones or skin. There is also great demand for processed meat products, like sausages or hamburgers, for which the source meat texture is not so important. In the case of beef, in USA, its minced form (also named ground beef) accounts for 40% of the total beef consumption (Beef USA, 2013). It is a belief that in the not so distant future there will be a satisfactory resemblance to natural meat, especially in its minced form.

## Nutrients

It is known for a long time that meat is nutritionally important. It provides not only proteins, but also vitamin B12, bioavailable iron and omega-3 fatty and amino acids (Bhat & Fayaz, 2011). In order for cultured meat to be competitive in the market it has to meet or even exceed the nutritional value of traditional meat. Since with in vitro meat

scientists try to reproduce actual skeletal muscle tissue, the amino acids and proteins are present in the final product (Langelaan et al., 2010). Vitamin B12 is synthesized exclusively by certain species of gut-colonizing bacteria and that is the reason it can only be found in products of animal origin. Addition of crystalline vitamin B12 which is produced commercially by biosynthetic microbial fermentation would be necessary in an in vitro meat product grown in an aseptic environment. Iron in meat is in the form of Fe<sup>2+</sup> iron which can be found in the highly bioavailable form of heme, which is the prosthetic group found in myoglobin (Datar & Betti, 2010). To provide iron to growing myocytes in a bioavailable form, Fe<sup>3+</sup> ions bound to the plasma binding protein transferrin will have to be supplemented to the culture medium. By transferrin-mediated iron transport, iron can enter the myocyte mitochondria and be incorporated into heme synthesis and subsequent myoglobin synthesis (Aisen et al., 2001). Both vitamin B12 and heme iron are exclusively found in meat. So it seems that scientists will be able to come up with a final product of similar nutritional value to natural meat.

## Color

To complete the visual resemblance, in vitro meat must have the pinkish-red color of traditional meat. But what makes meat look either red or white like in Figure 5?

To answer that, we have to be aware of the difference between slow-twitch and fast-twitch muscles. The former are used for extended periods of activity and need a consistent energy source. To extract that energy, excess oxygen is needed which is stored in muscle cells by

## Oxygen and myoglobin

Myoglobin is a protein in the muscles that binds iron and oxygen together, like hemoglobin does in blood. It gives meat its red color because it contains a pigment, and myoglobin also determines directly the iron content, which is an important nutrient.

the protein myoglobin. Myoglobin is a richly pigmented protein and the more there is in cells, the redder or darker the meat is (Miller, 1994). Fast-twitch muscles are used for quick bursts of activity, such as fleeing from danger. These muscles get energy from glycogen, which is also stored in the muscles (Exploratorium, 2014). Myoglobin is present in skeletal muscle cells in culture (Ordway & Garry, 2004) and contractile activation of muscle in hypoxia will stimulate myoglobin maximally. Also, the addition of food coloring is a generally accepted process. So the promise of in vitro meat looking like natural meat is not an impossible scenario.

All the previous characteristics of meat can be manipulated and therefore the possibility of different products with different qualities is not an imaginary scenario. With the establishment and adoption of functional and enriched foods, consumers are more willing to try products that have been altered to have particular nutritional characteristics (Korhonen, 2002; Burdock, 2006). By co-culture, medium formulation or genetic engineering, it is theoretically possible to create products with different taste, texture and nutrient profiles (Datar & Betti, 2010). Therefore in vitro meat can attract consumers interested in different combinations among the characteristics of their food. A cultured meat production system could theoretically be sufficiently compact and automated for every household to produce its own meat -- a "meatmaker" could sit next to every "breadmaker," using ingredients purchased at a store (Edelman, 2005).

Author: Dimitrios Vlachos

## Sources

Aisen, P., Enns, C., & Wessling-Resnick, M. (2001). Chemistry and biology of eukaryotic iron metabolism. *International Journal of Biochemistry and Cell Biology*, 33(10), 940–959.

BBC. (2013, August 5). World's first lab-grown burger is eaten in London. Retrieved, March 30, 2014, from: <http://www.bbc.com/news/science-environment-23576143>

Beef USA. (2013). Beef industry statistics. Retrieved, March 30, 2014, from: <http://www.beefusa.org/beefindustrystatistics.aspx>

Bhat, Z. F. and Fayaz, H. (2011). Prospectus

Figure 5. The color of the meat is important. It is determined mostly by the myoglobin content.

*Transformation-trainer.*



of cultured meat - advancing meat alternatives. *Journal of Food Science Technology*, 48(2), 125-140.

Bredahl, L., Grunert, K. G., & Fertin, C. (1998). Relating consumer perceptions of pork quality to physical product characteristics. *Food Quality and Preference*, 9, 8.

Burdock, G. A., Carabin, G. I., & Griffiths, G. C. (2006). The importance of GRAS to the functional food and nutraceutical industries. *Toxicology*, 221(1), 17–27.

Claeys, E. et al. (2004). Quantification of fresh meat peptides by SDS-PAGE in relation to ageing time and taste intensity. *Meat Science*, 67(2), 281–288.

Datar, I. and Betti, M. (2010). Possibilities for an in vitro meat production system. *Innovative Food Science & Emerging Technologies*, 11(1), 13-22.

Edelman, P.D. et al. (2005). In Vitro-Cultured Meat Production. *Tissue Engineering*, 11(5/6), 659-662.

Exploratorium. (2014). What gives meat its color? Retrieved, March 30, 2014, from: <http://www.exploratorium.edu/cooking/meat/INT-what-meat-color.html>

Goodwin, J.N., Shoulders, C.W. (2013). The future of meat: A qualitative analysis of cultured meat media coverage. *Meat Science*, 95(3), 445-450.

Humane Society. (2013, July 27). Farm animals statistics: Slaughter total. Retrieved, March 30, 2014, from: [http://www.humanesociety.org/news/resources/research/stats\\_slaughter\\_totals.html](http://www.humanesociety.org/news/resources/research/stats_slaughter_totals.html)

Jones, N. (2010). A taste of things to come? *Nature*, 468, (7325), 752-753.

Korhonen, H. (2002). Technology options for new nutritional concepts. *International Journal of Dairy Technology*, 55(2), 79–88.

Langelan, M.L.P. et al. (2010). Meet the new



meat: tissue engineered skeletal muscle. *Trends in Food Science and Technology*, 21(2), 59-66.

Mattick, C.S. & Allenby, B.R. (2012). Cultured meat: The systemic implications of an emerging technology. IEEE International Symposium on Sustainable Systems and Technology, ISSST 2012; Boston, MA; United States; 16 May 2012 through 18 May 2012; Category number CFP12SEE-ART; Code 92591.

Miller, R. K. (1994). Quality characteristics. In D. M. Kinsman, A. W. Kotula, & B. C. Breideman (Eds.), *Muscle foods*, 296-332. New York: Chapman & Hall.

Mottram, D. S. (1998). Flavour formation in meat and meat products: A review. *Food Chemistry*, 62(4), 9.

Ordway, G. A., & Garry, D. J. (2004). Myoglobin: an essential hemoprotein in striated muscle. *Journal of Experimental Biology*, 207, 3441-3446.

PETA. (2013). 14 steps that will evolve your views on eating animals. Retrieved, March 30, 2014, from: <http://www.peta.org/living/food/14-steps-will-evolve-views-eating-animals/>

Toldra', F., & Flores, M. (2004). Analysis of meat quality. In L. M. L. Nollet (Ed.), *Handbook of food analysis* (pp. 1961e1977). CRC Press.

Transformationtrainer. (2012, June 25). Red vs. White, which is better? Retrieved, March 30, 2014, from: <http://transformationtrainer.com/2012/06/red-vs-white-which-is-better/>

Verbeke, W. et al. (2010). European beef consumers' interests in a beef eating-quality guarantee insights from a qualitative study in four EU countries. *Appetite*, 54(2), 289-296.

## Scale and cost

Two technological issues regarding the future of in vitro meat

---

The first hamburger was extremely expensive. For in vitro meat to become a marketable product, two technical concerns are paramount.

---

Currently, in vitro meat is at the stages of infancy. Researchers are struggling with many issues at the basic level of tissue engineering for in vitro meat, and a commercial meat product which is fully made from in vitro meat is at least a decennium away. However, there is obviously huge potential, and there is a substantial market and moral pull for the technology. In this article, we will look at two questions regarding the future of in vitro meat: how to scale up, and how much will it cost?

So, what do researchers expect to do, after they've managed to make a small piece of meat under laboratory conditions? In a review article by Bhat and Fayaz on current in vitro food science, they look ahead without being too speculative. When the technical issues of growing a small culture have been addressed, they look at bioreactors for scaling up the process. Also, others in the field, such as Edelman, Mironov and Post, also indicated that bioreactors are probably the way to go, and for example surgeons also look at bioreactors to create new body parts for patients. Then, what are these bioreactors exactly?

Bioreactors are used in the pharmaceutical, biochemical and agriculture industry to produce something on a (relatively) large scale by means

of a biological process, for example fermentation or the production of pharmaceuticals. Bioreactors are often specifically designed to control a large set of variables, like temperature, the pH (acidity) or force exerted on of the stuff in the bioreactor. The idea is that, when we know the conditions under which our in vitro meat will grow, and we have designed a bioreactor that controls these conditions, we can simply throw in our premature meat cells and let them grow into a gigantic chicken breast or sausage, as long as we provide nutrition and a medium, a scaffold (a structure for the meat to grow on) and of course oxygen.

Although no actual research has been done on large scale bioreactors for in vitro meat, small laboratory reactors, which are 10 to 250 mL, have been scaled up to 3 L, and scientists think further scaling won't be a problem, at least in theory (Edelman, 2005; Bhat, 2010).

In these bioreactors, the earliest opportunity for producing some kind of artificial meat is meat from cell cultures. When you produce cell culture meat, you only aim at producing the cells, not the actual tissue. This is much easier, and although the product doesn't look anything like meat from livestock, it technically consists of the same muscle cells. This type of meat is

suitable for supplementing livestock meat, or be used for processed meats such as sausages and hamburgers. Two scientists in particular, van Eelen and Mironov, are involved in this type of meat production. Wim van Eelen's 1999 patent is for a cell culture production process, where he uses a collagen mesh where new cells are grown on. For NASA, Vladimir Mironov researched a production process where collagen spheres in a bioreactor provide a soil for the muscle cells to proliferate, however this research was cut short by NASA. Both approaches tackle a fundamental problem with bioreactors: in a petri dish, the number of cells is very small, and nutrition and oxygen can get to all the cells by simple diffusion; however, when you are scaling up, the cell complex becomes greater in volume, and at a certain point cells die because nutrition can no longer get to them. From Edelman: "cells become necrotic if separated for long periods by more than 0.5 mm from a nutrient supply." In live animals, muscle tissue has a structure including blood vessels that distribute nutrition, however creating meat with a structure in vitro, so like the actual live tissue, is much more complicated (this hasn't even been done in laboratory conditions), and commercial applications are far beyond the horizon.

If we use bioreactors to produce in vitro meat on a large scale, there is an added advantage: in principle, the entire production process can be robotized, which means no direct human contact is required and therefore it can be completely sterile. Currently, antibiotics are often used in culturing in vitro meat, at least while it is proliferating, and while there are options to remove it from the end product (Cultured Beef, 2011), it is of course preferred to never have to use antibiotics in the first place; a robotized, bioreactor production process would make this possible. This is also an added advantage when compared to normal meat, which sometimes contain substances to control disease and infection. So, in vitro meat bioreactors have the possibility to be safer, healthwise, than meat from animals.

One of the main figures in in vitro meat production is of course Mark Post, who produced the world's first IVM hamburger and was mentioned earlier as an advocate of bioreactors for IVM production. He is explicitly working towards a commercial product, not because he doesn't value fundamental research, but because he believes it is necessary because of sustainability issues. Because of his commercial focus, he has let some numbers shimmer through that gives us an indication of the costs associated with IVM. However, the first indication of the money involved comes from a Dutch government grant of €2 million euros, given out to Dutch researchers in 2004 (Chiles, 2013; Bartholet, 2011), among them were Wim van Eelen, Henk Haagsman and also Bernard Roelen. Bernard Roelen, a cell biologist, pointed out a major money sink for IVM production, the



Figure 6. A small, laboratory-scale bioreactor. *M. Janicki*

culture medium. The culture medium that is used currently, bovine fetal blood, is already quite expensive, and animal-friendly alternatives, such as algae or fungal media, are, to quote Bartholet and Jeffrey, "prohibitively expensive". "With currently available media, it might cost \$50,000 to produce a pound of meat, according to Roelen" (Bartholet, 2011).

\$50,000 for a pound of meat is cheap in comparison to Mark Post's first IVM hamburger, whose two patties of minced beef cost a staggering \$250,000, donated by Google's Sergey Brin, and some sources even report \$325,000 (Scientific American, 2013). However, out of the years Mark Post spent, only three months went into the actual production of the hamburger, the rest of the time, and money, was spent on exploratory research. When the IVM hamburger was presented and eaten in London in August 2013, Tom Gibson for Bloomberg TV Europe asked him how confident he (Mark Post) was that this can be mass-scaled. Mark Post replied: "I'm actually fairly confident that it can be mass-scaled. [...] Stem cell production for medical purposes, it has been scaled up. [...] We have run a number of calculations with one of the largest manufacturers of medical stem cells, and we found actually very good conditions for it to scale up and also to make it at an acceptable price at some point" (Cultured Beef, 2013). Later on, he commented on these calculations with: "We have done some calculations where we come up with a reasonable price actually, with the current technology, which is around \$70/kg. [...] This gives me sufficient confidence that eventually we can and scale it up and make it at an affordable price" (Cultured Beef, 2013; Scientific American, 2013). From the \$50,000 per pound that Roelen estimated, referring to laboratory-produced meat, Post's estimate of \$70/kg for a future large-scale biofactory seems more viable commercially, barring the immense initial investments required. In an interview with Nicola Jones for Nature magazine, Mark Post estimates a rough €100

million to commercialize the entire process (Jones, 2010). An analysis of the future of meat industry when in vitro meat enters the stage can be found at page 28.

All in all, in vitro meat is at an awkward spot. There is existing technology in the medical field, primarily bioreactors, that promises scalability to the IVM production process and an acceptable price for a commercial product. However, there are technological challenges to overcome in order to keep the meat in bioreactors from dying, and even more to produce anything other than minced meats. Beyond that, there is an enormous price tag on the initial investment, and little interest from commercial industry, which leaves us to say that a commercial product is probably decades away, despite van Eelen's early claims in 2007 that 'In another five years meat will come out of the factory' (Financieel Dagblad, 2007).

Author: Joris Luyt

## Sources

Bartholet, Jeffrey (2011). Inside the meat lab. *Scientific American*, Vol. 304 Issue, 64-69.

Bhat, Z.F., Fayaz, H. (2010). Prospectus of cultured meat – advancing meat alternatives. *Journal of Food Science Technology*, 125-140.

Chiles, R. (2013). If they come, we will build it: in vitro meat and the discursive struggle over future agrofood expectations. *Agric Hum Values* DOI 10.1007/s10460-013-9427-9.

Cultured Beef. (2013, August 5). The Event. Retrieved February 22 2014 from Cultured Beef: <http://culturedbeef.net/event/>  
Edelman, P.D. et al. (2005). In Vitro-Cultured Meat Production. *Tissue Engineering* 659-662.

Financieel Dagblad. (2007, December 12). Patent holder Willem van Eelen: 'In another five years meat will come out of the factory'. Retrieved March 6 2014 from <http://archive.is/EqNhZ>.

Jones, N. (2010). A taste of things to come? *Nature*, 468, (7325), 752-753.

Scientific American. (2013, August 5). Test-Tube Burger: Lab-Cultured Meat Passes Taste Test (Sort of). Retrieved March 6 2014 from Scientific American: <http://www.scientificamerican.com/article/test-tube-burger-lab-culture/>

# Cool meat

## Is in vitro meat a fantastic solution for global warming?

---

Conventional meat production lays a heavy burden on our environment. These concerns might be addressed by in vitro meat.

---

The Food and Agricultural Organization (FAO) warn us that human way of living is harmful for the environment (FAO, 2006). Especially after the release of the film 'An inconvenient truth', the awareness of climate change has risen. Nowadays, most people say or think that we have to care for our environment, but who is really doing something, and how can we intervene and stop the global warming process?

The livestock sector provides us with food like meat, eggs and milk, but also wool and leather. The Dutch livestock is already for a long time under discussion regarding environmental issues, because of the significant impact it has on the environment in many different ways. The impact on air and climate change, land and soil, water, and biodiversity is already huge, but it is also growing and changing due to the rising global demand (FAO, 2006). Livestock occupies 30 percent of the ice-free surface of the planet, through grazing and feed crop production. With this the livestock shapes landscapes and changes them due to the demand for food and other products (FAO, 2005). This impact on the environment will reduce natural habitats. All the waste products from animals will end in air, soil or water and cause all kinds of pollution.

Humans use natural resources all over the world to answer to the demands for food. With the increased use of all resources landscapes will not

be capable of self renewal, and cannot be used anymore (Westing, Fox and Renner, 2001). On the basis of this we can conclude that humans are responsible for this kind of pollution. Other pollution is caused by the introduction of animals into a small landscape. The animals will gaze and produce huge amounts of emission gasses, for instance methane, produced by cows, which is very harmful for the environment. A Pentagon report stated that it is not terrorism we have to worry about, but our way of living, and our food habits cause global warming, which lead to drought or famine (Schwartz and Randall, 2003).

Tuomisto says that the introduction of in vitro meat will reduce, for instance, the harmful greenhouse gasses. These gasses have an influence on global warming and reduction can probably be a part of the solution for this problem (Tuomisto, 2011). The only problem right now is that it is speculative. As Henk Haagsman mentions in his interview "All the calculations are based on assumptions". These assumptions are based on the fact that the use of land, need of water, and animals will change after the introduction of in vitro meat. These changes for the environment can be made visual with the change in the life cycle after the implementation of in vitro meat (Figure 7).

In the life cycle where animals are farmed for meat production, there is a need for huge amounts of water to have grass on the meadows.

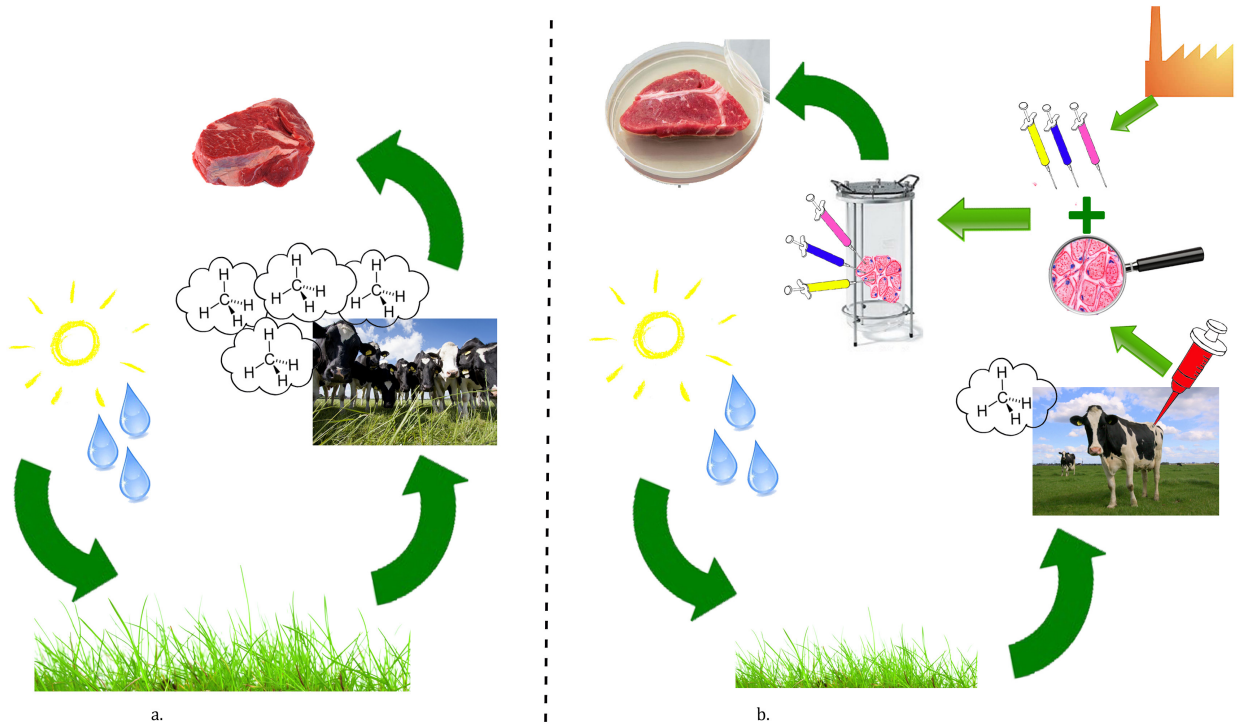

Figure 7. With the introduction of in vitro meat, the life cycle will change. The left life cycle (a) shows the normal process where we need the sun and a huge amount of water to have grass. Then there is a meadow where a large amount of cows can graze, produce high amount of methane, and eventually slaughtered to produce meat. In the right life cycle (b) the same sun is shining, but a lower amount of water, land, and cows is necessary to require cells for a biopsy. Besides these cells, nutrients are needed, and the production of in vitro meat will possible be finished with the use of a bioreactor in a laboratory.

Large amounts of cows graze these meadows, producing high amounts of methane. The cows are slaughtered eventually and the meat can be processed. If in vitro meat is introduced, this life cycle will change. For the animals there is still a need for sun and water. However the size of a meadow can decrease, due to the decrease in the amount of animals needed. For example: a cow is just needed once in a while to take a biopsy. The cells required will be processed and with the addition of nutrients, the process can possibly be completed in a bioreactor. After all steps taken in the laboratory, in vitro meat is produced. On the one hand the changing life cycle causes a decrease in the amount of water,

energy, land, emission gasses from animals, and animals, but on the other hand, new processes take place for the development of nutrients and energy needed for all processes in the laboratory. However this energy can be assumed to be much less. Ultimately, when we find stem cell lines, we do not even need any live animals anymore for the production of in vitro meat.

The assumption is that with the production of in vitro meat, the objections concerning the environment could be overcome. If in vitro meat takes over the 'normal' meat consumption, fewer cows and other animals will be needed, and these animals could be farmed in better conditions. According

Figure 8. This graph shows a comparison of energy use, greenhouse gas emission, land use and water use of in vitro meat with the conventionally farmed beef, sheep, pork and poultry per 1000 kg meat. *Tuomisto (2011)*.

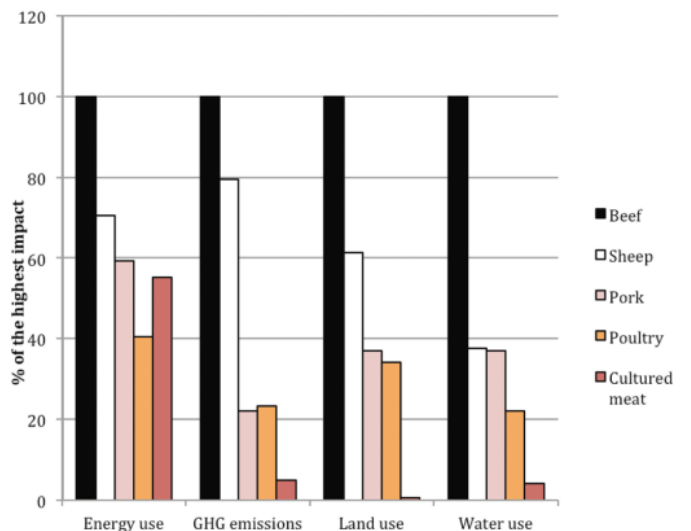

to this the total amount of animals will decrease, and thereby energy use, land use, water use, and gas emissions will be reduced (Figure 8). As mentioned before, cows have a high methane production, which is a damaging greenhouse gas and will probably reduce with the smaller amount of cows needed for beef production. To show the enormous impact you can compare the numbers for traditional beef production and in vitro meat production. For the production of in vitro beef: 99% fewer land is needed for farming, 45% fewer energy is needed, 95% fewer water is necessary and there will be 96% fewer emission (Tuomisto, 2011). This will make a huge step towards the solution for all problems.

This all seems very promising, but there is another side, because we do not have farms only as an answer to the (rising) demands for meat. We also need huge amounts of animals for eggs, milk, wool, leather and all other dietary products. Not only the demand for meat is globally rising, but also the demand for other products has increased in the last years (FAO, 2006b). We will still need huge (harmful) farms to answer these demands, for instance with cows for leather, cheese and milk production (Abbate, 2013). The assumption is that the production of in vitro meat will reduce the pollution and harm of the environment. However, if we want to know if this is really a solution we have to wait for commercial success of in vitro meat into the market with a large market share.

Author: Karin van Leersum

## Sources

Abbate, Cheryl E. (2013 August 13). 6 reasons why you should not support in vitro meat! Retrieved December 24, 2013, from wordpress: <http://aphilosophersblog.wordpress.com/2013/08/13/6-reasons-why-you-should-not-support-in-vitro-meat/>

FAO. (2005). Pollution from industrialized livestock production. Livestock Policy Brief No.2 FAO.

FAO. (2006). FAO statistical database. Rome.

Ministry of Economic Affairs. (2014 february 1). Reduced and Responsible: use of antibiotics in food-producing animals in the Netherlands. Retrieved March 18, 2014, from Government of the Netherlands: <http://www.government.nl/issues/agriculture-and-livestock/documents-and-publications/leaflets/2014/02/28/reduced-and-responsible-use-of-antibiotics-in-food-producing-animals-in-the-netherlands.html>

Schwartz, P. & Randall, D. (2003 October). An abrupt climate change scenario and its implications for United States national security. Retrieved March 18, 2014, from Greenpeace: <http://www.greenpeace.org/international/Global/international/planet-2/report/2006/3/an-abrupt-climate-change-scena.pdf>

Tuomisto, H.L. and de Mattos, M.J. (2011). Environmental impacts of cultured meat production. Environmental science & technology. Vol. 45; pp. 6117-6123.

Westin, A.H., Fox, W. & Renner, M. (2001). Environmental degradation as both consequences and cause of armed conflict. Working paper for Nobel Peace Laureate Forum participants by PREPCOM subcommittee on Environmental Degradation

# An introduction to the social challenges for in vitro meat

Almost 80% of the responders in our survey are positively to the idea of eating in vitro meat. An important issue for in vitro meat, which has nothing to do with its technological make-up, is for instance the name. Mirjam Galetzka says: “By labelling this ‘in vitro’ we got all these associations with small babies and laboratories” (Galetzka, 2014). Cor van der Weele says: “In Dutch we have the word ‘Kweekvlees’, which is even worse than in vitro meat. Everybody agrees that the word is not very attractive for most people, and many people have been thinking about better names”. However she thinks: “Once it is ready for the market, I think that the people who will take it to the market will come up with the name” (Weele, 2014).

If livestock is grown only for other products than meat, the prices for these products will increase. However, Henk Haagsman does not consider this as a major problem: “It will never happen that no animals will be slaughtered for meat, so there will be always skin for leather or all kinds of collagen or whatever. We have seen in the past that people like to have leather chairs, but nowadays there exists many other products to replace leather for chairs. There is artificial leather and the quality of these products is very high” (Haagsman, 2014).

World hunger is under investigation within the social sciences, thereby the meat consumption is rising globally. The assumption is that in vitro meat will cause overconsumption, however Henk Haagsman thinks: “I do not think that people will eat more meat if animals do not need to be slaughtered. If you eat rice you are not killing animals and still people are not eating a lot of rice or wheat” (Haagsman, 2014).

These are just some of the many important social aspects that surround in vitro meat. In the next part of the magazine these social issues will get the attention they deserve. First, the acceptance and incorporation in the industry will be discussed at page 28. More about the immense importance of marketing can be read at page 32. In vitro meat can be seen as a possible solution for world hunger, but whether that is definitely the case is discussed at page 35. Also the possibility that vegetarians and religious humans will buy in vitro meat is examined (see articles page 38 and 42).

## Sources

Galetzka, M. (2014, March 7). Interview on marketing and in vitro meat.

Haagsman, Henk. (2014, February 14) Interview on technological aspects of in vitro meat.



Van der Weele, Cor. (2014, February 27).  
Interview about the ethical aspects around in vitro  
meat.

# The meat colossus

## Exploring the meat industry by making a social map

---

### The meat industry will definitely change after the introduction of in vitro meat. What does this entail and will the industry accept and adapt?

---

Nowadays the meat sector has a lot of specialized farms, with different branches for slaughtering, meat processing, and distribution. The Dutch meat industry is one of the big players in the international market. This is not only due to the large amount of animal farms, but also by the well-known processing knowledge from the Dutch. The large scale of Dutch distribution is caused by innovative products, knowledge of the demands, and quality assurance (Vlees.nl, 2012). It is an interesting fact, because with in vitro meat it is again the Netherlands at the base of the knowledge, and probably also the pioneer in the distribution of in vitro meat. Although in vitro meat seems as a very promising product, the industry is not really interested right now (Post, 2013). So the question arises: 'Will the meat industry accept and incorporate in vitro meat, and will it become an accepted product within the meat industry?'

In the current meat industry there is high amount of regulations which is changing continuously and cause difficulties for the industry. Some examples of such regulations are the introduction of antimicrobial packaging for food (Quintavalla et al., 2002), reduction of salts (Desmond, 2006), and traceability and knowledge of the production techniques (Mousavi et al., 2002). All these separate measures are introduced for the

provision of highly safe and quality meat. Take for example the traceability during the production process, which provides confidence in the integrity and origin of the product (Mousavi et al., 2002). All the measures will come with problems during implementation, and thereby high costs. High costs can of course be problematic for some sectors in the industry. Not only because they need to incorporate changes in the production processes, but also they need to accept these changes. Therefore, the current meat industry is already reluctant towards changes in their production processes, even before in vitro meat is introduced to them.

Also, healthier foods are not very likely to be bought by consumers by virtue of its healthiness. For example, in meat there are important nutrients, which can be used to produce functional food. This functional food can increase the healthiness of products, but it is hard to accomplish and produce it with a reasonable price. Therefore the consumer often does not buy these products, but choose for the unfortified meat (Decker & Park, 2006; Olmedilla-Alonso et al., 2013). So, by analogy, the industry is not likely to invest in vitro meat production if consumers are reluctant to buy. More on this consumer response can be read in the article concerning marketing on page 32.

The source of meat production - farms or barns - are also struggling with specialized regulations. Another example, producers of biological meat, with support from supermarkets and the government, caused a slight increase in the demand for biological meat (Vlees.nl, 2012). Due to this farmers, who want to have a biological farm, have to deal with many regulations before they can transform their farm into one which is allowed to produce biological meat. As a farmer stated: "For the mark 'biological enterprise' you need to fulfill special criteria, and you have to be careful whether you can survive" (Müller, 2014). The introduction of in vitro meat will come with even more difficulties for the farmers to incorporate, and therefore with substantial risk.

Until this moment it is unclear how the meat industry will react to in vitro meat as a future product. The question is still if they will accept and even incorporate it. To answer this question, Henk Haagsman says: "I would say that when we started, the conventional meat producers would write articles about the negative effects, but now they see it will take a long time, and it is not that all the meat production will be, within 15 years, replaced by cultured meat". The industry sees it realistically and knows that it will take some time (Haagsman, 2014). Another reason that we do not know how the industry will accept or incorporate can be caused by the uninterested position the

industry took the last years. Mark Post said about investing by the industry: "Most companies are not interested in long term development." He also thinks that the food companies think that in vitro meat is a really revolutionary improvement. But he also said: "Now some companies become interested and hopefully worldwide emphasis on this technology may foster that" (Post, 2013).

As mentioned, it is not clear if the industry will accept and incorporate in vitro meat within the current industry. With the use of the social construction of technology (SCOT) approach, a possible answer can be formulated for the question 'If in vitro meat will be introduced into the supermarket and replace normal meat, what will change in the industry?' When we have an answer for this question, we can perhaps argue if the meat industry will accept and incorporate in vitro meat or not. Different social groups will be influenced by the change, such as farmers, workmen at slaughterhouses and process factories, and the consumers. With the development and introduction of in vitro meat, workmen at laboratories will be added to the meat industry and the social map. The social map of the meat industry with the production of in vitro meat is sketched in figure 9.

Nowadays work in the meat industry is divided in the agricultural, slaughter, processing, and

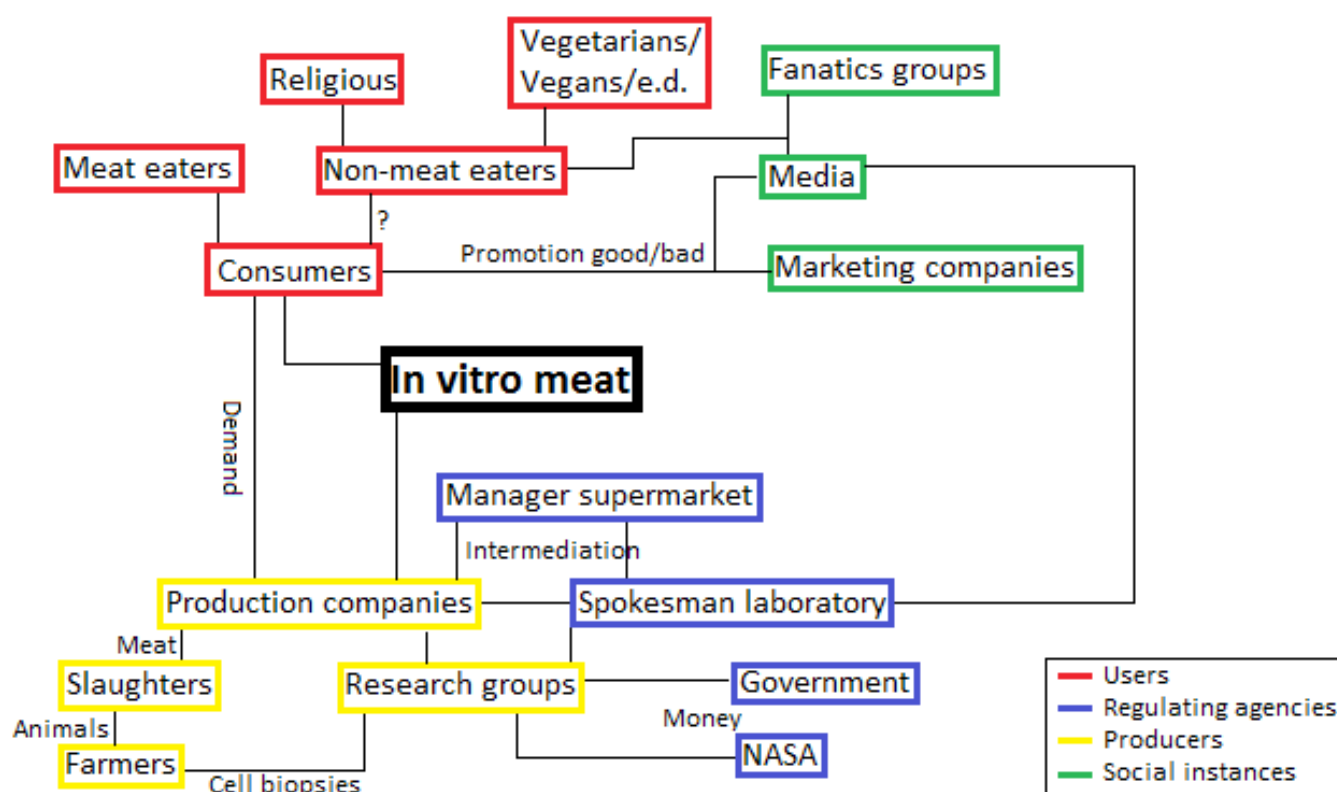

Figure 9. Social map for in vitro meat. A social map shows the relevant social actors for a particular technology, and their relations, in the framework of Social Construction of Technology (SCOT) theory. Different categories of social actors, such as users or regulating agencies, will have different agendas concerning in vitro meat, and thus you can implicitly see the different meanings in vitro meat has for different sections of the meat industry. That is one of the heuristic powers of a social map.

distribution sector (Vlees.nl, 2012). Let's first examine the agricultural sector, where farmers have huge farms full of animals. Probably after the introduction of in vitro meat, this large amount of animals is not needed anymore, which will cause changes to farms. Farm with huge barns and land can be replaced by small barns, and the land can be used for other purposes (Müller, 2014). For instance, with this change the farmer will just need a couple of cows to take care of (see article page 54). On the one hand this is great for animal welfare. On the other hand does the farmer want this change and can the farm still survive economically? It seems therefore that farmers probably would not accept it.

The work of a farmer will drastically change, but the work of workmen in the slaughtering sector will probably disappear. Currently they have to slaughter all the animals which are used for food, not only in the Netherlands, but also for the distribution to other countries (Vlees.nl, 2012). For in vitro meat only cell biopsies have to be taken, which is friendlier for the animal, and clearly different from slaughter. There is the option that workmen from this sector will specialize to take these biopsies, however gathering of cells is only necessary once in a while. Massive and extensive farms are no longer needed, and slaughterhouses become obsolete. The slaughtering sector will be in serious trouble with the introduction of in vitro meat, probably there will always be some animals which need to be slaughtered, but most of the workmen from the slaughterhouses will lose their job. Although the reduction in slaughter will have a positive reaction on the consumers, because of animal welfare, there are dire consequences for the profession slaughter.

The same applies for the production and distribution sectors, where nowadays the Dutch meat industry is one of the biggest due to the well known processes (Vlees.nl, 2012). The processing of 'normal' meat will change if we will only eat in vitro meat. It is possible that the production of in vitro meat will be combined with the work done in laboratories. The laboratories are responsible and at the base of the development of in vitro meat. They will start with the production process, however for large scale production factories need to be built. With this change it is possible that the production is wholly taken over by laboratories and new specialized 'bioreactor' factories. With this, only the distribution processes will be fully done by the currently known distribution sector. However right now there is no large scale development of in vitro meat, so we cannot predict how this will evolve.

If in vitro meat is introduced into the supermarket the consumer will obviously be an important group. Who will eat this meat and who does not want to eat it? To formulate an answer to this we have to take the view people have regarding meat and maybe food as a whole. Right now there are

already different views regarding meat, take for example vegetarians. More about the way we see food and if consumers, vegetarians and other will accept in vitro meat as food can be found further in this magazine (see article page 50). The meaning meat has for consumers will change with the introduction of in vitro meat. In the survey we wanted to investigate what people know about in vitro meat right now and what their initial reaction was. We can measure influential aspects, like price, taste, in vitro meat has according to the 124 respondents (see article page 32).

The news media form a social group not only influencing in the development of in vitro meat, but especially influential during the introduction of in vitro meat. It is an important factor because it can play a role in the acceptance and the position people will take regarding in vitro meat compared to traditional meat. This is not only the acceptance of in vitro meat into the society as a whole, but also for the meat industry. Henk Haagman mentions that journalists are very interested in all different aspects of in vitro meat, especially the ethics, however the technique behind the product is less interesting (Haagsman, 2014). If the media is positive around the development and the real product, consumers will probably eat it and then the meat industry will eventually accept it. The other way around is also possible, in which the industry will cause negative publicity around in vitro meat, if they do not accept it. It is possible to measure the reactions of consumers on the basis of positive or negative media and marketing. At the moment the familiarity and there is little knowledge about in vitro meat. If a survey similar to ours would be done, after a lot of positive or negative publicity around in vitro meat, the outcomes of both surveys can be compared, and changes can be measured and made visible.

The in vitro meat technology is not fully developed right now, we need for instance production in a broader scale before implementation is possible. Thereafter not only the meat industry will change, that has to accept and incorporate in vitro meat, but also public acceptance is necessary. This all is based on assumptions and we do not know what will happen, but there will definitely be a change. Besides this the meat industry cannot simply start making small portions of in vitro meat. The production of 'normal' meat and in vitro meat are not compatible, as shown by the SCOT theory analysis. The reluctance of industry to adapt to current regulation and consumer changes indicates that a great deal of inertia needs to be overcome in order for in vitro meat to be incorporated in the current meat industry. This opens up the possibility of another, separate production network for in vitro meat, but that is another issue which we will not investigate further.

Most of the work in the meat industry will probably change, work can be combined within laboratories

and factories, and life on the farm will be different. So to revisit the question: 'Will the meat industry accept and incorporate in vitro meat? As you have read in this article, the industrial process and network around in vitro meat will be very different compared to normal meat. This poses a challenge for the introduction and acceptance of in vitro meat, and with this the willingness of the industry to accept and incorporate in vitro meat right now. The meat industry was not interested in in vitro meat yet, but this is changing (Post, 2013). Eventually the industry has to understand and accept that it is influenced by the introduction of in vitro meat into the market, and that changes will really happen. After introduction, they need to accept and incorporate in vitro meat within the current meat industry.

Author: Karin van Leersum

## Sources

Decker, E. A. & Park, Y. (2010, April 15). Healthier meat products as functional foods. *Meat Science*. Vol. 86, pp 49-55.

Desmond, Eoin. (2006, April 24). Reducing salt: A challenge for the meat industry. *Meat Science*. Vol. 74, pp 188-196.

Haagsman, Henk. (2014, February 14) Interview on technological aspects of in vitro meat.

Mousavi, A. et al. (2002). Tracking and traceability in the meat processing industry: a solution. *British Food Journal*. Vol. 104, No. 1: pp. 7-19.

Müller, W. (2014, February 17). Interview kweekvlees en de boerderij.

Olmedilla-Alonso, B. et al. (2013, March 19). Development and assessment of healthy properties of meat and meat products designed as functional foods. *Meat Science*. Vol. 95, pp 919-930.

Post, Mark. (2013, August). Burger Tasting Londen. Retrieved February 27, 2014, from [culturedbeef.net: http://culturedbeef.net/event/](http://culturedbeef.net/event/)

Quintavalla, S., Vicini, L. (2002, May 14). Antimicrobial food packaging in meat industry. *Meat Science*. Vol. 62, pp 373-380.

Vlees.nl. (2012 August 7). Cijfers en feiten. Retrieved January 31, 2014, from [vlees.nl: http://www.vlees.nl/dossiers/economie/cijfers-en-feiten/](http://www.vlees.nl/dossiers/economie/cijfers-en-feiten/)

# Brave new meat

## The marketing of in vitro meat

---

It is a long way for in vitro meat from laboratory to supermarket shelf, and marketing might be the most important factor for success.

---

In vitro meat could be completely safe, cheaper than normal meat and better for both the environment and animals; if the average consumer does not accept it, then this might stop a large-scale in vitro meat take-off. Marketing is thus an important part of the in vitro meat future, which will be explored in this article.

In the survey that was conducted for this magazine it was found that about 19% of the respondents reacted with a yuck-reaction on hearing of in vitro meat and that the other parts of the audience show either a 'wow' reaction, a reaction showing interest but with some reserve or other reactions. These proportions correspond to research as can be seen in figure 10.

For marketers, it is a challenge to sell the product to as many people as possible. There are however many choices: would they want to focus on the minority group already positively interested, try to get the attention of the people who have some reserves ('interesting, but..') or even try to persuade the people who had an initial yuck-reaction? It seems that in general it is assumed that in vitro meat will be placed next to the 'ordinary' meat in the supermarket, where it will compete mainly on price and animal friendliness. However, there are other roads in vitro meat could take. It could

for instance compete with other meat substitutes or even try to start its own 'domain' in the form of a niche market. Thus although it seems logical that regular meat will be mimicked as precise as possible, this is not necessarily the only strategy possible. Marketers could for instance also target early adopters first, who might pick up the product while it is still relatively unknown. This group might then help the product grow into a more regularly accepted meat.

Mark Post argues that the acceptance of the general market should not be a problem if the packaging of 'real' meat contains a sticker which indicates that for making that meat animals have suffered; people should then quickly change their mindsets, all other factors being equal, to buy in vitro meat. From a marketing communication perspective, this however seems too naïve of an approach. To see this, a distinction can be made between the intrinsic and the extrinsic qualities of the product; the intrinsic qualities are the ones you experience when actually 'using' the meat; the taste, texture, smell etcetera; the extrinsic qualities are all those 'around' the intrinsic ones: the packaging, the claims that are made and the image for instance. The technicians involved with in vitro meat clearly focus on the intrinsic factors, but the extrinsic factors play a role that is often

## Initial in vitro meat reactions

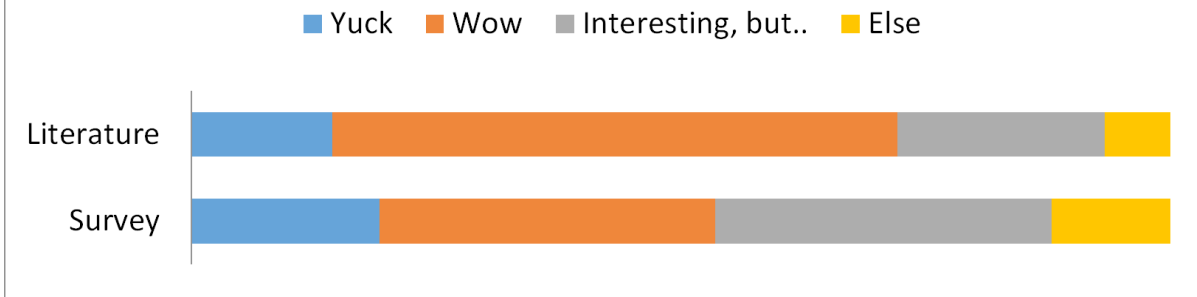

Figure 10. Initial in vitro meat reactions: from literature averages were taken from the given ranges; the survey responses were categorized within one of the categories. All initial reactions are also represented in the front page image.

even more important, especially with products that have not proven themselves to the consumer yet (Galetzka, 2014).

Considering the extrinsic factors, future in vitro meat producers have a wide choice. The different possible consumer targets are an important determinant for which extrinsic qualities of the meat are most important (Galetzka, 2014). The most daring step to make seems to try to make in vitro meat really the new standard. For this, the yuck-factor, an initial response of disgust, would have to be taken away, which is a very big challenge of itself (Cor vd Weele bron) and in this sense it seems unfortunate that the picture in one's mind does not become more appetizing when one knows more about the process of creating in vitro meat: the 'feeding' of the muscle cells has to be done by a quite complex serum and to get realistic meat, muscles must be 'trained' by letting them contract by electricity shocks. Important factors for disgust are the association with putting something in one's mouth that can have unpredictable consequences (Weele, 2010). Fascinating in this case is that although these images of the production of one's food are indeed not the most attractive, neither are many associations with the current meat industries: animals are fed until they become much bigger than they would have naturally become; are kept alive by a variety of supplements and antibiotics; have a tiny living space; and most people deliberately do not even want to know what goes into their 'frikandel'.

Taking away the yuck-factor is one of the major challenges to make in vitro meat a new standard, but even if this disgust can successfully be taken away, there are enough challenges to be overcome. As said (and according to Post) it might seem that if the ethical advantages of in vitro meat – no animals were harmed in the process – could be enough to market it to the bulk of people: Research done on other meat substitutes however shows that only a small segment of the market is actually sensitive to such claims (Hoek et al.,

2013). Consumers do value ethical aspects of products, but their behavior is not consistent with these favorable attitudes, which is also called the "attitude-behavioral intention gap". It is this gap that makes 'ethical' products such as fair-trade and sustainable organic products have less than 1% of market shares while 30% of consumers indicate to have positive attitude towards such products (Vermeir & Verbeke, 2006). This is a gap that comes predominately forth out of perceived barriers of lack of availability, inconvenience and price, but also from a low 'perceived consumer effectiveness', which means that the consumer believes he can only contribute nothing more than a negligible part of the solution to a problem. This gap can be crossed by communication efforts and provision of information but this is all but straightforward (Vermeir & Verbeke, 2006; Hoek et al., 2011). So even though around a third of the audience has an initially positive reaction, this does not mean their action would necessarily correspond with this reaction.

### Buying behaviours

In the survey that was conducted for this magazine, the respondents were asked to rank different factors influencing their buying behaviour, for both the 'regular' meat and what they would expect for in vitro meat. Cost and quality were ranked about equal and were thought significantly more important than animal or environmental friendliness for regular meat. However, 20% of the respondents considered environmental friendliness as one of the most important properties and 30% animal friendliness. For in vitro meat, safety is a new factor that is very important. Other than that, the rankings stay about equal compared to regular meat, only price becomes a little less important with in vitro meat.

An important thing for crossing this bridge between attitude and behavior and the factors that were mentioned causing it, is the challenge of 'credence quality'. It is the issue of making consumers believe your company claims, which they can often not check themselves. An issue with in vitro meat might be that people think it is not safe, as our survey showed with 80% thinking it was a critical factor for buying it. It is then up to the company to somehow convince the customer it is, which presents a big challenge. The same goes for the overall animal friendliness; there are wild stories on the internet on the use of fetus serum in the production of in vitro meat. While technological experts clearly indicate that this was only used in first experimental in vitro meat production, it is this kind of unsupported stories that have to be overcome and credence qualities, convincing consumers of qualities and claims they cannot check themselves, are an obstacle that should not be underestimated.

Arguably the most important extrinsic factor, and even the most fundamental marketing element of all, is the naming of the product. Mark Post indicated that simply calling it the same as ordinary meat and emphasizing the differences by other means would be enough in practice. However, relating in vitro meat to ordinary meat has its own challenges. What is important to keep in mind, is that in vitro meat and ordinary meat are not per se the same kind of products; meat could just be seen as an analogy for in vitro meat; something that can be related but is fundamentally different. As explained, if the average customer sees them as two kinds of the same food, it seems in vitro meat is predominantly more scary than the ordinary meat. Thus, naming does not necessarily have to be linked to ordinary meat, but also another side might be chosen that focuses more on the 'vegetarian' part of in vitro meat, in that no animals are killed for it (whether vegetarians will actually accept in vitro meat is discussed on page 38).

Naming can have serious implications and especially for technological products it is a challenge to find a name that on the one hand shows what the product is but on the other hand does not scare people with images of technological dystopias. 'Genomics' as a term is given as an example of something that sounds too 'technological' and therefore scares people. While this word for the field of genetic mapping was thought up over a beer after a meeting in 1986, it been said to have had important negative consequences for the attitude of the general public towards the field of genomics (Yadav, 2007).

If marketers want to make a new standard out of in vitro meat, a lot of challenges are present: first there is the initial 'yuck' factor and then there are the other extrinsic qualities that have to convince the consumer to actually try the product. That ethical arguments alone are not enough to convince the

bigger public, is an additional difficulty and that their behavior is not necessarily predictable by their (initial) attitude. It seems that by these challenges future in vitro meat producers could either try to compete on price as an additional factor, or focus more on smaller market segments that do have a bigger focus on environmental and animal friendliness arguments. In that sense it is important to consider that 34% of the survey respondents did already react with a 'wow'-reaction and could for instance be targeted as early adopters that can provide a supporting base for a larger acceptance.

Overall, marketing and the choices to make will present an important challenge; as futurologist Ray Kurzweil puts it: "we'll need a marketing genius to sell the idea" (Time, 2010). The results from our survey however show the benefits if it is done well: without any further information, 65% of the respondents would buy a 'regular' hamburger, 21% a vegetable alternative and only 15% an in vitro burger. After making the respondents assume that all factors (price, taste, texture) of these burgers are equal, only 15% would choose a 'regular' hamburger, 29% a vegetable one, 17% would not care and 40% would choose the in vitro hamburger. Thus if potential customers can be assured of these factors, big shifts can happen.

Author: Wouter Versluijs

## Sources

- Galetzka, M. (2014, March 7). Interview on marketing and in vitro meat.
- Hoek, A. C. et al. (2013). Are meat substitutes liked better over time? A repeated in-home use test with meat substitutes or meat in meals. *Food Quality and Preference*, 253-263.
- Hoek, A. C. et al. (2011). Replacement of meat by meat substitutes. A survey on person- and product-related factors in consumer acceptance. *Appetite*, 662-673.
- Time. (2010, December 6). 10 questions for Ray Kurzweil. Retrieved March 17, 2014, from Time: <http://content.time.com/time/magazine/article/0,9171,2033076,00.html>
- Vermeir, I., & Verbeke, W. (2006). Sustainable food consumption: Exploring the consumer "attitude-behavioral intention" gap. *Journal of Agricultural and Environmental Ethics*, 169-194.
- Van der Weele, C. (December 2010). In-vitrovlees: Yuck!(!?). Wageningen: LEI.
- Van der Weele, C. & Driessen, C. (2013). Emerging Profiles for Cultured Meat; Ethics through and as Design. *Animals*, 647-662.
- Yadav, S. P. (2007, December). The wholeness of suffix -omics, -omes and the word om. *Journal of Biomolecular Techniques*. 18(5): 277.



# World hunger

## Food security and in vitro meat

---

While we struggle with environmental and moral issues, developing countries fight a long battle versus hunger. Is in vitro meat the answer?

---

We eat too much. Or, we eat too much in the developed countries, where hunger is almost non-existent, and food readily available for nearly every inhabitant of these countries. According to the Food and Agriculture Organization (FAO) of the United Nations, we were already producing enough food worldwide in 2009 to feed 150% of the world's current population (FAO, 2009), which inspired Eric Holt-Giménez, and others, to write a paper with the title "We already grow enough food for 10 billion people... and still can't end hunger." The question is: why can't we end hunger? We have the food; we just have to distribute it more evenly, right?

This perspective is, of course, too naive. Hunger is a complex issue, and while food production is a factor in global hunger, there are many more. The issue of food shows a huge discrepancy between developed and developing countries: problems with food inhabit totally different dimensions. In developing countries, there is one, major issue with food: hunger. Ironically, developed countries deal with obesity, but problems that transcend excess consumption are moral, environmental and sustainability issues. In this article, we will examine the state of hunger in developing countries, and what role in vitro meat production can play in this.

World hunger is actually a misnomer for the problem that'll be discussed. More accurately, global organizations and governments speak of undernourishment rather than hunger, having a diet with insufficient energetic value. Furthermore, organizations and governments are no longer trying to address hunger directly, they only do this during crises, for example natural crises (earthquakes, drought) or political crises (war, political instability). Rather, they address the problem of a lack of food security, and during the World Summit of 2009 it was defined as: "Food security exists when all people, at all times, have physical, social and economic access to sufficient, safe and nutritious food, which meets their dietary needs and food preferences for an active and healthy life." Global organizations focus on food security, because it's a bigger problem, of which one of the consequences is hunger, and even when people aren't hungry currently, they are still hungry potentially in the future while there is no food security for them. So, providing food security to underdeveloped countries is a more difficult goal, but it's a more resilient solution, and the European Commission said in 2012, in the context of world hunger crises and food security, according to the IFPRI (International Food Policy Research Institute) in the Global Hunger Index 2013: "Addressing the root causes of recurrent crises is not only better than only responding to the consequences of crises, it is also much

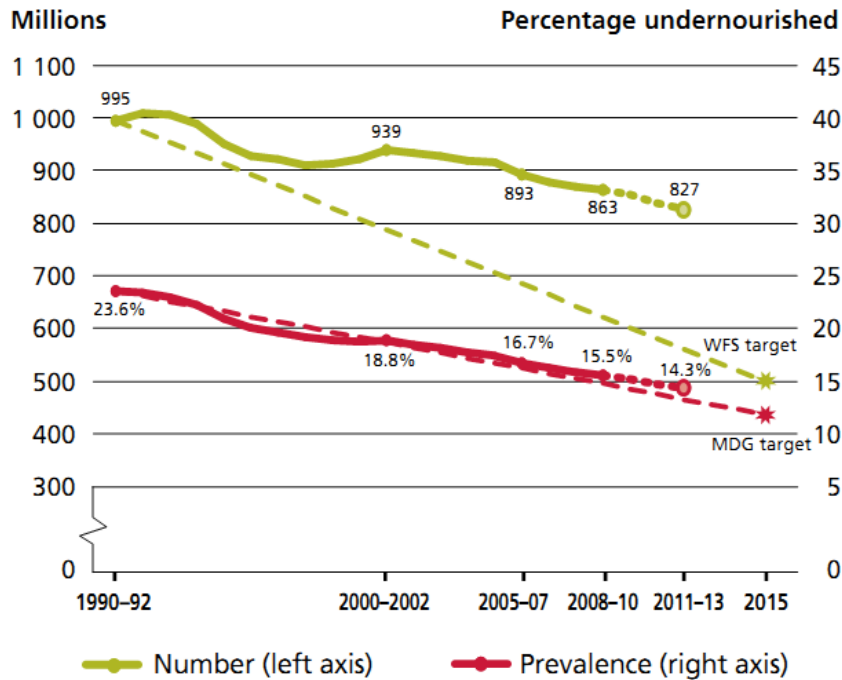

Figure 11. Undernourishment in the developing regions: actual progress and target achievement trajectories towards the MDG and WFS targets. Data for 2011-2013 refer to provisional estimates. Adapted from "The State of Food Insecurity in the World 2013". *FAO, IFAD and WFP. (2013)*

cheaper." Many reports from leading authorities on world hunger, such as the IFPRI and FAO, suggest lasting solutions to food security that offer autonomy and resilience to local population rather than 'quick and easy' fixes for hunger. But we're getting ahead of ourselves.

In 2000, during the Millennium World Summit, the nations of the UN set themselves 8 goals, among them reducing child mortality, promoting gender equality and eradicating extreme hunger (undernourishment). More concrete, Millennium Development Goal Target 1.C (MDG Target 1.C) is to halve the proportion of people, between 1990 and 2015, who suffer from hunger. During the World Food Summit of 1996 a stricter goal was set (WFS target), over the same time period, to halve the amount of people that suffer from hunger. This WFS target is, considering the population growth in developing countries (an average of 4.53 children born per woman (World Population Prospects, 2012), extremely hard to fulfill. With the end of the period less than a year away at the time of writing, graphs from the FAO's 2013 report "The State of the Food Insecurity in the World" give us a good indication of where we stand on these two targets, see Figure 11.

It's plain to see that in a year's time, the WFS target will not be reached, and that we're not on track of meeting the MDG target 1.C, although we are close. However, the good news is that both the proportion and the absolute amount of undernourished has decreased, despite the world's population increase of approximately 2 billion people, mainly in developing countries, where 98% of the world's hungry live (FAO, 2013). But this graph only tells a small part of the story. Many regions have progress in line with the MDG target 1.C, for example Latin America and Asia overall, but Africa actually saw a minor decrease in the proportion of undernourished and an absolute increase. In Sub-Saharan Africa, the most troubling region, the proportion went from 17% to 26% and the absolute number

of hungry increased by 50 million (FAO, 2013). On the opposite, in Asia, China has made great progress, going from a Global Hunger Index Score (a quantitative measure of hunger used extensively by the International Food Policy Research Institute), of 13.0 (serious) in 1990 to 5.5 (moderate) in 2013, while India only went from 32.6 (extremely alarming) to a 21.3 (alarming) (IFPRI, 2013).

If this torrent of numbers becomes dazzling, it suffices to say that some areas of the world make good progress in battling hunger, undernourishment and food security, while others are falling behind severely. Southern Asia (including India) and Sub-Saharan account for more than 60% of the undernourished (FAO, 2013). Despite these mixed results, and the failure to meet the targets, the combined initiatives in the context of the MDG Target 1.C are the most successful global anti-hunger campaign in history.

Now that we know the seriousness and extent of world hunger, let's look at what is being done to address it. Organizations and government aim at providing food security, rather than battling hunger, unless there is some crisis or shock. Without going into specific cases, the FAO has developed a framework to analyze and battle food insecurity around the world, called the suite of food security indicators. On a global scale, this is the most recognized framework in which hunger problems can be addressed, and it consists of multiple dimensions. First of all, there is availability, of which the average supply of protein of animal origin is one indicator. The others are access (physical and economical), utilization, vulnerability and crises. Initiatives in this context specifically aim to improve one or more of these dimensions. One thing to note is that hunger (or food insecurity) is by no means a direct function of food production or even availability. Rather, food insecurity is often a result of inequality and injustice (Chronic Poverty Advisory Network, 2012). More important than

availability in developing countries is access to food (FAO, 2010) and resilience to crises (FAO, 2010; IFPRI, 2013). Some specific issues for agricultural communities, where food insecurity is great, are that they lack proper knowledge and technology to utilize their food production capabilities, and poverty and lack of resilience to economic and climate crises is even more widespread (Chronic Poverty Advisory Network, 2012).

With the complexity of food security, it seems doubtful that future in vitro meat can make substantial difference, even if it were to become the cheap, easy and safe source of animal protein that it is only hypothetically right now. In this case, in vitro meat would only contribute to one indicator of food availability, which is a dimension of food security that's of lesser importance, and thus its overall impact would be near to negligible. But the in vitro meat account gets worse. In vitro meat technology can come in two types: large, government controlled, centralized plants, which might even be controlled by another nation (for example a developed nation), or a decentralized, small, local technology, that allows local entrepreneurs (for example farmers) to exploit the technology.

In the case of centralized in vitro meat production, the division between rich and poor will become even greater. The poor population already has little access to resources, and now they can either choose to become dependent on a centralized technology, or continue their old ways, ignoring in vitro meat technology. Either way, in vitro meat technology will be a source of inequality, which, according to multiple authorities on world hunger, is already a cause of food insecurity. It would also go directly against current mentality of providing self-sustaining, durable and local solutions, since in vitro meat technology is simply a technology that provides food availability, no other dimensions are addressed by it. Beyond that, the world's poorest, the so-called base of the pyramid, living with less than \$4 per day (Jauregui, 2013), would never be able to afford meat on a regular basis in the first place: in vitro meat should be much cheaper than normal meat, if the world's poorest were to buy it regularly, and this scenario seems unlikely. Thus, centralized in vitro meat technology shouldn't be pushed for developing countries as a solution to hunger and food insecurity, it will, at best, have a negligible impact.

The situation would look better if in vitro meat technology would be introduced in a decentralized fashion: local farmers could set up their own in vitro meat farm and provide their community with a source of food, stable food prices (economic access) and decrease in physical access requirements (e.g. railroad and roads). Additionally, decentralization in general is less vulnerable to crises, adding resilience to crises to the list of potential advantages. Finally, providing local communities with in vitro meat technology is a valuable resource: a source of wealth and work (Sumberg, 2006). Using decentralized in vitro meat technology as a solution to food

insecurity definitely seems promising; however the technological hurdle is enormous. Current food cultivation techniques in developing countries are primarily outdated technologies. In Sub-Saharan Africa and Southern Asia, there is a substantial lack of effective technologies (even simple technologies such as a pump well) and an even greater lack of technological expertise. Technology as a tool against poverty in developing countries requires that they're very simple technologies (Jauregui, 2013), and stem cell bioreactors do not, even slightly, fit this bill.

If you are looking to solve the world's hunger problems using in vitro meat, then you are probably on the wrong track. While in vitro meat technology has the potential to contribute something to the battle against world hunger if it's implemented in a decentralized manner in developing countries, however this is far, far off and other initiatives against food insecurity are probably more effective. On the surface in vitro meat appears to be a promising option, but in reality it offers very little to food security for developing countries. For the foreseeable future, in vitro meat technology will only suit the needs of developed countries.

Author: Joris Luyt

## Sources

Chronic Poverty Advisory Network (2012) Meeting the challenge of a new pro-poor agricultural paradigm.

FAO. (2009). The state of food insecurity in the world. Rome, Italy: Economic and Social Development Department Food and Agriculture Organization of the United Nations.

FAO. (2010). "Global hunger declining, but still unacceptably high".

FAO, IFAD and WFP. (2013). The State of Food Insecurity in the World 2013. The multiple dimensions of food security. Rome, FAO. Holt-Giménez, E. et al. "We Already Grow Enough Food for 10 Billion People ... and Still Can't End Hunger".

IFPRI. (2013). "Global Hunger Index: The challenge of hunger: building resilience to achieve food and nutrition security".

Jauregui, J. M. (2013) "Product development: lifesaver for the BoP?" Presentation during Technolab classes at the University of Twente, the Netherlands.

Sumberg, J. (2006). A log row to hoe: family farming and rural poverty in developing countries. Retrieved March 16, 2014, from Eldis: [http://www.eldis.org/go/topics/resource-guides/agriculture-and-food&id=31397&type=Document#.UzltpKh\\_uE4](http://www.eldis.org/go/topics/resource-guides/agriculture-and-food&id=31397&type=Document#.UzltpKh_uE4)

World Population Prospects. (2013). The 2012 Revision – Department of Economic and Social Affairs, Population Division, of the United Nations.

# Vegetarian meat?

## A vegetarian perspective on in vitro meat

---

### In vitro meat can be produced without harming animals. Will this persuade vegetarians to eat meat or will they still object to it?

---

From what has been written so far, it seems that in vitro meat is coming in our lives and researchers believe that it is coming to stay. While a big part of those who will switch or at least try in vitro meat will be current meat eaters, there is an uncertainty about what 'line' vegetarians will follow. In this article we will address the several disputes that in vitro meat gave rise to.

First of all we must clarify what we mean by the term vegetarian. "Vegetarianism is the practice of abstaining from the consumption of meat, red meat, poultry, seafood and the flesh of any other animal". Of course there are many different categories of vegetarians (ovo, lacto, ovo-lacto vegetarianism, veganism or raw-veganism, fruitarianism and several others) and there have been several disputes and disagreements between them. But, for the sake of simplicity, by vegetarian we will refer to people not eating meat.

If we could sum up the most important reasons for which someone becomes a vegetarian we would definitely come up with the following: animal rights, health, environmental reasons (of course there are many more but those three are the ones found repeatedly) (Altenet, 2008; Vegetarian times, 2014; PETA, 2014). It is relatively easy to defend the three of them. The mass slaughter of

billions of animals each year and the cruel and unacceptable conditions they grow in and are transported until they die is enough for many to turn to vegetarianism. The recent fatalities from mad cow disease and avian flu, the excessive use of antibiotics (Tavernise, 2013) and the connection of meat to heart diseases (Pendick, 2013) are only some of the health related effects of meat (besides those derived from overconsumption). Furthermore, excessive use of water and energy, and the immense land usage by the meat industry (Brooks, 2004), are the main but not the only environmental side-effects associated with meat consumption. As a general claim, those who are in favor of in vitro meat, tend to see it as a food supplement and not as a meat replacement (Mattick C.S. and Allenby R., 2012). Among them is PETA. As its vice president Bruce Friedrich said, referring to cultured meat, "it is the best thing since sliced bread" (Altenet, 2006). Moreover, it was PETA that in 2008 has promised one million dollars as a reward to any laboratory that will use chicken cells to create commercially viable in vitro meat (PETA, 2014).

We would expect that since in vitro meat promises to address and partially solve the main problems for which someone would become a vegetarian, that there would be some mutual agreement

between advocates of in vitro meat and vegetarians. But despite these clear arguments there is a conflict depending on the prism under which in vitro meat is examined. Cultured meat can be seen as unnatural (Vegangstaz, 2012). The power of the “yuck factor” that was already mentioned before and the denial because it’s not ‘natural’ should not be underestimated (Hopkins P.D. and Austin Dacey, 2008). Another issue is that of “moral cowardice”. Instead of genuine moral work, humans choose a technological quick fix (no matter how sophisticated this fix really is) (Weele, C. and Driessen, C., 2013; Vegetarian society, 2013a). Many see behind in vitro meat a huge obstacle for those who want to reach veganism (Vegan society, 2010). Simply put, cultured meat only promotes vegetarianism (on the very literal meaning of the word) and mass suffering will continue on animal farms to produce dairy products and eggs. Others see a back door to potential cannibalism (In vitro meat, 2012). The fact that in vitro meat has not been thoroughly tested for its effects on humans also gives rise to questions about its safety (Seed magazine, 2009). Another reason is the amount of money spent on research that, ideally, could be spent elsewhere (Abbate, 2013).

Had we not done the interviews with experts on the field, we (the writers) would have an incomplete opinion about in vitro meat. While there are a lot of questions to be answered one should not forget how innovative (and therefore controversial and

open to criticism) this technology is. Just some quotes from the experts that were interviewed for this magazine towards cultured meat:

- Regarding moral cowardice, Cor van der Weele: “So there are moral reasons to do it (cultured meat), it is not dissociated from moral concerns, and on the contrary it is done for moral reasons, animal welfare and sustainability..... So in vitro meat will also but slower change morality and values”
- The “yuck factor”, Henk Haagsman:” People don’t like technological aspects in food production. They want to have original food, old-fashioned food and they don’t want all the modern technology although they don’t realize that there is a lot of technology in every culture and food production...All food development starts in the laboratory but they are produced in the factory. And this prevents people from seeing that it is not a laboratory product. It is developed in lab like many things are developed. They are not produced in laboratories, this is a big difference”.
- On cannibalism, Cor van der Weele:” Well yeah, I think it is quite logical that it turns up, because you don’t have to kill an animal for in vitro meat. I think that if everything works as it is meant to work, you only have to some cells, so the same can be done from a human being, why not? Technically it will be exactly the same”

Figure 12. How often do you eat meat? In our survey 9% (out of a total of 124 participants) declared to be vegetarians/vegans. Approximately 800.000 people, or about 5% of the total population, do not eat meat in the Netherlands (Volkskrant, 2012).

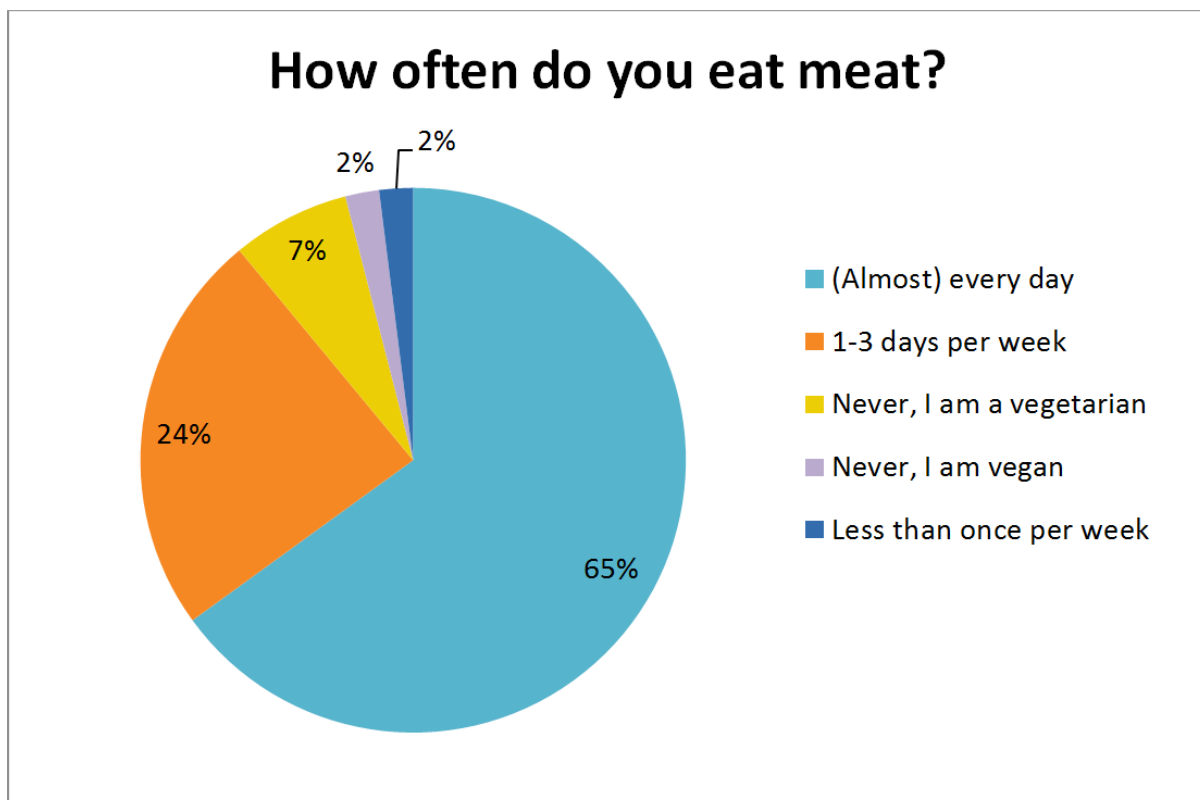

• On the prize by PETA, Henk Haagsman: "You always know it takes much longer to have a product in the supermarket if it is completely new. It takes so many years so they could easily promise 1 million dollars. Because nobody would be able to produce and have the stuff in the supermarket all over the country."

We can easily understand that there are several uncertainties even among people of similar beliefs when it comes to the possible outcomes of a novel technology.

This lack of uniformity lies in the fact that it will dramatically change the view that people have about something as important and necessary as our nutrition. In our own survey, when people were asked if vegetarians would eat that type of meat, only 27% replied emphatically either yes or no. The majority were still uncertain about their response. In a poll on the Vegetarian Society's website 79.86% (as of 5 August 2013) have stated that they would not eat in vitro meat while 6.91% have said they would (vegetarian society, 2013b). On the other hand, the largest community of vegetarians in the world is not only advising vegetarians to adopt in vitro meat but is actually willing to financially award its development.

Everyone should bear in mind that in vitro meat is still on research level and many ethical/social/technical aspects have to be dealt with. Ask a scientist working with it and will tell you that we are still far from an optimum result. Supporters of in vitro meat never claimed that it is the solution to all problems related to our diet. But it's a start, a great start, towards a goal that could even be the complete vanishing of animal suffering for food and the end of meat-derived diseases. If we want to solve all of the above objections it's up to us to demand further improvements in what we eat. If we want to develop into complete moral beings who don't consume any type of meat from respect towards animals, in vitro meat is not the enemy. It will just help save billions of animals until (and if ever) we reach that point. To conclude, food for thought by Mark Post: "Vegetarians should remain vegetarian. That's even better for the environment" (The daily beast, 2013)

Author: Dimitrios Vlachos

## Sources

Abbate, Cheryl E. (2013 August 13). 6 reasons why you should not support in vitro meat! Retrieved December 24, 2013, from wordpress: [http://philosophersblog.wordpress.com/2013/08/13/6-](http://philosophersblog.wordpress.com/2013/08/13/6-reasons-why-you-should-not-support-in-vitro-meat/)

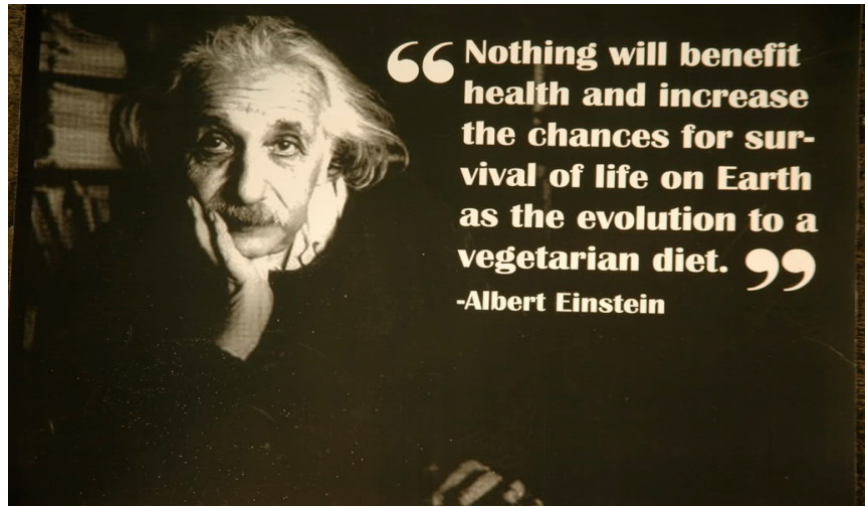

Figure 13. Albert Einstein commenting on vegetarianism. Did he include the possibility of in vitro meat in his thoughts?

reasons-why-you-should-not-support-in-vitro-meat/

Alternet. (2006, July 11). Would you eat lab-grown meat? Retrieved March 24, 2014, from Alternet: [http://www.alternet.org/story/38755/would\\_you\\_eat\\_lab-grown\\_meat](http://www.alternet.org/story/38755/would_you_eat_lab-grown_meat)

Alternet. (2008). Top ten reasons to go vegetarian. Retrieved March 24, 2014, from Alternet: [http://www.alternet.org/story/85828/top\\_ten\\_reasons\\_to\\_go\\_vegetarian](http://www.alternet.org/story/85828/top_ten_reasons_to_go_vegetarian)

Brooks, C. (2004). Consequences of increased global meat consumption on the global environment – trade in virtual water, energy & nutrients. Stanford Woods Institute for environment.

Hopkins, P.D., Dacey, A. (2008). Vegetarian Meat: Could Technology Save Animals and Satisfy Meat Eaters? *Journal of Agricultural and Environmental Ethics* 21(6), 579-596.

In vitro meat. (2012). Arguments against in vitro meat. Retrieved March 24, 2014, from In vitro meat: <http://invitromeat.us/articles/arguments-against-in-vitro-meat/>

Mattick, C.S., Allenby, B.R. (2012). Cultured meat: The systemic implications of an emerging technology. *IEEE International Symposium on Sustainable Systems and Technology, ISSST 2012; Boston, MA; United States; 16 May 2012 through 18 May 2012; Category number CFP12SEE-ART; Code 92591.*

Pendick, D. (2013, April 17). New study links L-carnitine in red meat to heart disease. *Harvest health publications.*

PETA. (2013). Top 10 reasons to go vegan in the new year. Retrieved March 24, 2014, from PETA: <http://www.peta.org/living/food/top-10-reasons->

PETA. (2014). PETA Offers \$1 Million Reward to First Person to Make 'Test Tube' Meat. Retrieved January 1, 2014, from PETA: <http://www.peta.org/features/vitro-meat-contest/>

Seed magazine. (2009, November 16). In-vitro meat – pros and cons. Retrieved March 24, 2014, from wordpress: <http://petridishtoplate.wordpress.com/2009/11/16/in-vitro-meat-pros-and-cons/>

Tavernise, S. (2013, December 11). F.D.A. restricts antibiotics use for livestock. Retrieved March 24, 2014, from New York Times: [http://www.nytimes.com/2013/12/12/health/fda-to-phase-out-use-of-some-antibiotics-in-animals-raised-for-meat.html?pagewanted=all&\\_r=1&](http://www.nytimes.com/2013/12/12/health/fda-to-phase-out-use-of-some-antibiotics-in-animals-raised-for-meat.html?pagewanted=all&_r=1&)

The Daily Beast. (2013, July 8). Can vegetarians eat in vitro meat? The debate rages. Retrieved March 24, 2014, from The Daily Beast: <http://www.thedailybeast.com/articles/2013/08/07/can-vegetarians-eat-in-vitro-meat-the-debate-rages.html>

Vegan society. (2010). In vitro meat = distraction from vegans. Retrieved March 24, 2014, from Vegan Society: <http://www.vegansociety.com/news/In-vitro-meat-is-distraction-from-veganism.aspx>

Vegangstaz. (2012). This ist he end. Retrieved March 24, 2014, from Vegangstaz: <http://vegangstaz.wordpress.com/>

Vegetarian Society. (2013a). Press statements from the vegetarian society. Re-laboratory grown burger. Retrieved March 24, 2014, from Vegetarian society: <https://www.vegsoc.org/vs-pages/vs-home/press/press-releases/vs-home-press-release-laboratory-grown-meat->

Vegetarian Society. (2013b). Lab grown meat. Retrieved March 24, 2014, from Vegetarian society: <https://www.vegsoc.org/polls>

Vegetarian Times. (2014). Why go veg? Retrieved March 24, 2014, from Vegetarian Times: <http://www.vegetariantimes.com/article/why-go-veg-learn-about-becoming-a-vegetarian/>

Van der Weele, C., Driessen, C. (2013). Emerging profiles for cultured meat; ethics through and as design. *Animals*, 3(3), 647-662.

Volkscrant (January 27, 2012). Vleesvervangers voor dummy's. <http://www.volkscrant.nl/vk/nl/2844/Archief/archief/article/detail/3140047/2012/01/27/Vleesvervangers-voor-dummy-s.dhtml> retrieved April 8 2014



# Holy meat

## In vitro meat and religion

---

If major religions ban in vitro meat, the chances for commercial success will drop greatly. Will this be the case?

---

Marketing could present one of the biggest challenges for in vitro meat. Because the vast majority of all people is religious, it is interesting how these religions would stand towards the 'new meat'; religious institutions will have to act upon in vitro meat. Christianity seems to have no problems with in vitro meat. However, especially from the Islam (22.74% of the world), Hinduism (13.8%) and Judaism (0.22%) (CIA, 2013) in vitro meat raises questions as whether it can be accepted from the ground beliefs.

Although there are discussions, in vitro meat seems to be accepted by Muslims as halal. As long as the meat is not cultured from cells of animals that are not allowed to be eaten, such as pigs, Muslims seem to be able to accept this type of meat (Heneghan, 2013).

For Hinduism, eating any cow cells is beyond the question, but besides that in vitro meat might be accepted. However, within Hindu religion, some schools view vegetarianism as the ideal. This makes India the country with relatively the most vegetarians (The Hindu, 2013). For these vegetarian Hindus, in vitro meat raises the same questions as were discussed on 37 in the article on vegetarianism.

For Jewish people, the question is whether in vitro meat can be regarded as kosher. There are disputes whether in vitro meat can be accepted

### Kosher and Halal

In Jewish religion, the books of Leviticus and Deuteronomy prescribe both (some) kosher foods and kosher rules. The most important 'unclean' animal is the pig, but also hares and camels are unclean, and 'crawling creatures', such as bats and mice. Products from non-kosher animals such as milk and eggs are also considered unclean. Kosher laws prohibit certain ways of food preparation. The most important (but also contested) one is that kosher food can only be prepared by Jewish people.

The Islamic Shari'ah prescribes the prohibited foods and ways of food preparation. Pork is the most important prohibited meat. Furthermore, any animal that is not slaughtered in the name of Allah should not be eaten. The food should be prepared by a Muslim and the animal has to be slaughtered by cutting the throat with a sharp knife. Also blood should be detracted from the meat.



as such, but the general opinion seems to be that if the animal whose cells are used is killed according to the kosher law, it could be allowed. An interesting 'model' that could be used in Judaism is what the Talmud tells of "miraculous meat" that fell from heaven or was conjured up by rabbis studying a mystic text. This meat was accepted because it was not directly gained from animals. In vitro meat might even help solve problems in regulating kosher slaughtering methods (Mordanicus, 2013). Technical in vitro expert Henk Haagsman also indicated that the meat would be considered kosher if bovine (cow) and not porcine (pork) cells are used, which is possible.

It is important that the principles of these large religions seem to not reject the eating of in vitro meat, in the sense that the meat can be marketed also to religious people. This is also an important issue if one thinks of it as a possible solution to world hunger, as discussed on page 35 in the article on world hunger and food security.

Author: Wouter Versluijs

## Sources

Central Intelligence Agency. (2013). The World Factbook. Retrieved March 8, 2014, from Cia.gov: <https://www.cia.gov/library/publications/the-world-factbook/geos/xx.html>

Heneghan, T. (2013, August 9). Religions asking if test-tube burgers allow them to keep the faith. Retrieved March 6, 2014, from Reuters: <http://www.reuters.com/article/2013/08/09/us-science-meat-religion-idUSBRE9780V020130809>

Mordanicus. (2013, August 10). Dutch rabbi declares in-vitro meat to be kosher. Retrieved March 8, 2014, van Republic from Lagrangia: <http://republicoflagrangia.org/2013/08/10/dutch-rabbi-declares-in-vitro-meat-to-be-kosher/>

The Hindu. (2013). Hindu and Vegetarianism. Retrieved 2013, from <http://www.thehindu.com/2006/08/14/stories/2006081403771200.htm>

# An introduction to philosophical reflection on in vitro meat

The technical and social challenges have been addressed, the issues to resolve have been presented. What the reader might have been missing are articles that go deeper into the more fundamental changes that in vitro meat might cause. In this last part of the magazine we give a reflection on in vitro meat with the use of ethical and philosophical theories.

“Analogies that were used in discourse most often for in vitro meat were margarine and Quorn, a meat substitute on the basis of a fungus, but also genetic modification. The most important analogy however, is meat. So all discussion on in vitro meat, is in the end on meat itself.” (Hedwig te Molder) The question is thus whether in vitro meat will be ready to eat, because it is on the one hand fundamentally different from the regular meat and on the other hand very comparable. This issue is addressed on page 50.

Another interesting aspect of in vitro meat is that it could change the relation humans have towards animals, now that animals do not have to be slaughtered anymore for their meat. This issue is reflected upon on page 54.

Instead of developing a more moral behavior towards the killing of animals for human

consumption, technology will offer an ‘easy’ getaway. ‘Moral cowardice’ like Cor van der Weele mentions: “On the one hand there are those people who think that in order to solve the problem of overconsumption of meat, in vitro meat is not a real solution, what you can call moral cowardness. And on the other hand there are those people who will say it will be great if it work and if we all change our eating habits” (Weele, 2014). This issue is both a moral one that is shortly mentioned in the article on moral obligations to in vitro meat on page 46 but it also ties into a more elaborate philosophy by Martin Heidegger, as is discussed on page 56.

“For the technology to become integrated, the in vitro meat eater needs to find an identity that that can be seen as appropriate in his interaction” (Molder, 2014). It is hard to stand up as an individual, but Cor van der Weele also says: “You still can do things, because you can actively be in favor of for example in vitro meat. So there are different views off what you can do to take your values seriously” (Weele, 2014). These are all things that were found in discussions around in vitro meat. One of these values is for instance the natural that is often seen as good by default. These moral values that are addressed for in vitro meat are discussed on pages 46. Furthermore,

although one could consider the partakers in an online discussion layman, they often address philosophical arguments like these, which is explained in the sidebox on page 57.

Do not ponder upon these issues for too long, we already did it for you! We hope the next section will give the philosophical input you have been longing for.

## Sources

Cor van der Weele. (2014, February 27). Interview about the ethical aspects around in vitro meat.

Hedwig te Molder, (2014). Interview concerning in vitro meat.

# A moral analysis

## Putting in vitro meat to trial

---

There has been and likely always will be a strong moral debate on ‘normal’ meat production. How does meat produced in vitro fare morally?

---

It is a common thing when doing a literature research to come across several interesting articles. Sometimes, when examining different papers, it happens that an article is continuously cited, making it a kind of a bible for the field one is interested in. If you want to analyze possible moral objections to in vitro meat, then look no further. ‘Vegetarian Meat: Could Technology Save Animals and Satisfy Meat Eaters?’, written by Patrick D. Hopkins and Austin Dacey in 2008 is what someone, who is interested in cultured meat skepticism, will stumble upon repeatedly. The two authors go through a plethora of objections and give their opinion to each one. Here we will present their arguments and try to analyze them further.

First issue is the reality of in vitro meat. Many would deny considering it as real meat and call it artificial. In this case the plastic flower example is very successful. In vitro meat does not only look like meat but shares common properties with current meat and can become even identical with extended research. What makes meat real is its constituent substance rather than the mode of production. The plastic flower is artificial because it only looks like a flower. In terms of content and properties is different than its real counterpart. Also, we should reconsider how

‘real’ the meat we eat nowadays is. The presence of antibiotics, hormones and several toxins that can cause serious health problems (PETA, 2011) is somewhat neglected despite the amount of information that are available to consumers.

Many object to consumption of in vitro meat due to its unnaturalness. In this case, we should consider why something not natural is also bad? Many natural things are not good for humans. And what part of the slaughterhouse is actually natural? Actually, maybe this deviation from nature is the most important advantage of in vitro meat: the fact that we can humans can consume meat without killing billion of animals. To add to that, we should also think that there is no similarity between in vitro meat and the much debated genetically modified organisms. During the process of creating cultured meat there is no alteration of the genetic material.

The yuck factor, the feeling of disgust and aversion, is an argument mentioned in several articles (Weele, 2013; Weele, 2010; Goodwin, 2013) and it is a reaction met in our survey as well. To deal with it, two questions need to be answered. How important should we judge disgust and to what extent do people actually continue to feel disgust when educated and informed about



TRIAL OF A SOW AND PIGS AT LAVEGNY.

Figure 14. One of the most bizarre human-animal trends of all recorded history took place in Europe during the Middle-Ages. This was the formal prosecution of animals accused of committing crimes against people. In this article, the pig is replaced by its meat in cultured form and people by morality. <http://theoddmomentemporium.tumblr.com/post/30957539546/animal-trials-one-of-the-most-bizarre>

or familiarized with a new process? For the first question the roots of our disgust are important. Different cultures for example consider different things disgusting. Think of how many things non-educated people find disgusting that others do not and vice versa, think of how many teenage actions are met with revulsion from older people, think of how many people think that eating a horse is worse than eating a cow. What we have to ask ourselves is whether there is a moral issue. For the second question, let us just think how many people enjoy their meat ignoring (willingly or not) the pain and torture of an animal. Just an hour on Youtube has led people to rethink their eating habits. Imagine yourself witnessing the slaughterhouse...

We can approach this yuck factor in two ways: from the social sciences, marketing provides a perspective on how to overcome the disgust and make in vitro meat a commercial product (see marketing article page 32). Philosophically, we can analyze how disgust connects with what we consider food, and what it means for food. This has moral implications for in vitro meat, since it motivates people to make normative statements. Cor van der Weele has researched the yuck-factor extensively, and drew some philosophical conclusions. Some initial disgust reactions are based on analogies with genetically modified food, or the association of 'messing around with food'. Fundamentally, disgust is three things in van der Weele's framework. First, disgust can be caused by revulsion from oral incorporation; this

links disgust directly to food. Many things are not 'yuck' unless you are forced to eat them. Physical threat constitutes the second kind of disgust; and finally potential contamination is another idea that causes disgust. The reminder of life (animals and ourselves) in our food is also a yuck-factor for some, and in vitro meat will probably not remind people of it. However, safety concerns and the oral incorporation of in vitro meat lead to disgust. In the "In vitro meat for dummies" article (see page 8) and "Scale and cost" article (page 20) it is established that safety concerns are ungrounded, but laymen are often not well educated on this subject. Technical misconceptions on in vitro meat can therefore lead to disgust. Also, the idea

The wisdom of repugnance, or the yuck factor, also known informally as "appeal to disgust", is the belief that an intuitive (or "deep-seated") negative response to something, idea or practice should be interpreted as evidence for the intrinsically harmful or evil character of that thing. Furthermore, it refers to the notion that wisdom may manifest itself in feelings of disgust towards anything which lacks goodness or wisdom, though the feelings or the reasoning of such 'wisdom' may not be immediately explicable through reason. More contemporary research by Cor van der Weele on the yuck factor has been addressed in this article.

of electrical stimulation of the cell culture, a form of perceived physical threat, is off-putting (Weele, 2010).

Another famous moral objection is the so-called moral cowardice or the technological fix (Weele, 2013; Miller 2013). For many the technological solution is an easy way to avoid genuine moral work. If the target is a deontological approach such as cleansing our souls then maybe a technological solution is not the optimum. But if the target is saving innumerable animals from death and that is mediated by technology, even by appealing to our selfishness, would not it be immoral not to try it and just wait for a later moral enlightenment? Related to the previous argument, some oppose a solution based on selfishness and opt for self-sacrifice and virtue. From a consequentialist point of view, the target is not to boost our morale but rather relieve animal suffering. In some cases what keeps many to insist on eating meat is the absence of an acceptable intermediate step between consumption and abstention. Besides that, people can make a virtuous decision by choosing in vitro meat instead of meat deriving from the death of an animal. Moreover, moral vegetarians will be given an extra option that will not affect their virtue. By presenting people with only one virtuous choice we are in danger of achieving the opposite result. In our case people are given more alternatives and certainly their choices can be judged on moral terms. This also shows that in vitro meat is not morally neutral technology: it has strong ties with consequentialist ethics. Anyone with different ethical viewpoints would likely not contribute to the development of in vitro meat, but opt for something else.

Another worry is that people will feel more comfortable to continue eating meat with the promise of cultured meat in the future. It is quite hard to examine how people will be affected by a technological future promise. The arguments against eating meat stand despite what the future holds. Someone who is thinking to become a vegetarian will not be influenced by that, since there is also no clear indication as to when this technology will be established.

There is also the belief that animals' lives are better in a world with a meat industry at its present form rather than in a world of vegetarianism. Basically what this argument implies is that it is better to allow the 'coming into the world' of an animal, even for consumption, rather than restricting its birth by regarding it as unnecessary. This can only be seen as negative on the assumption that the transition from an animal-based to an in vitro meat economy will take place suddenly. For a significant period of time both types will coexist and maybe livestock derived meat will never be abolished. If eventually in vitro meat will prevail, then a gradual decrease in the number of livestock animals will take place up until no animal is born for slaughter. Besides that, there are claims that animals have intrinsic

### Consequentialism and deontology

Consequentialism, as its name suggests, is the view that evaluation of somebody's actions should depend only on its consequences. The most prominent example is consequentialism about the moral rightness of acts. This holds that whether an act is morally right depends only on the consequences or on something related to it, such as the motive behind the act or a general rule requiring acts of the same kind. Deontological theories are normative theories which disregard the consequences of actions, but rather only look at the actions themselves and whether they are morally required, forbidden, or permitted. And within that domain, deontologists stand in opposition to consequentialists. (Alexander and Moore, 2012).

value and promoting the birth of an animal even for consumption increases intrinsic value. The intrinsic value of something is said to be the value that that thing has 'in itself' or 'for its own sake,' or 'as such,' or 'in its own right.' (Zimmerman, 2010). Well, that is based on two contested hypothesis: that intrinsic value exists and that more is better. Furthermore, farm animals can still be bred but for reasons of humane dairy production, for products like sheep's wool or for companionship as pets.

The protest against the morality of in vitro meat continues with the claim that enjoying it is wrong for the same reason that eating human meat is wrong: it shows a lack of moral regard, dignity and respect. The animal source has a moral status which we violate by treating it as a means for consumption. Firstly we should think of the current moral status of animals and their treatment by the meat industry. Secondly, it is not the animal that is instrumentalized but its cells and tissues. If they are obtained in an acceptable way then it is the resulting meat that is being used for consumption and pleasure. And if cells and tissues are claimed to deserve a moral regard, then we should also reexamine blood and bone marrow transfusions in the case of humans. What in vitro meat manages to do is disconnect meat consumption from the animal itself.

Finally, there is a possibility that in vitro meat could promote (victimless) cannibalism (Tuson, 2011). The writers respond to that by stating that only a small percentage of consumers will be willing to eat human meat and also, since no human has to be killed, there is an uncertainty concerning the immorality of such an action. Moreover, in the interview we had with Cor van der Weele, she supported the same. They do acknowledge though that there is ground for

discussion. In general, when people react to the notion of cannibalism, they do so because mainly it presupposes the death of a human being for consumption. With the introduction of in vitro meat and the disconnection from the act of killing, even cannibalism will have to be redefined.

Morality and technology are not rival fields. On the contrary, morality is necessary to be present from the development of a technology until its establishment and in its use after that. Every technology should include our moral vision of a better world. And cultured meat includes one, when it is related to the lessening of animal suffering and slaughter. So can we draw conclusions about the connection between morality and in vitro meat? The answer is yes but extended discussion and individual education and information is of prime importance. All in vitro meat offers to the world is meat disconnected from death. So the answer to the title's question seems to be clear for Hopkins and Dacey: innocent on all counts when viewed under consequentialism. But for us there can be no absolute answer because behind in vitro meat we see the missed chance of humanity to re-evaluate some of its most profound beliefs and choose intense moral work instead of a technological fix. Further analysis into that is given in the article about Heidegger. Moreover, some people feel disgust towards in vitro meat; that has normative implications for in vitro meat. All in all, in vitro meat addresses some morally problematic consequences of 'normal' meat consumption, and Hopkins celebrates this, but in vitro meat is not totally morally innocent.

Author: Dimitrios Vlachos

## Sources

Alexander, L. and Moore, M. (2012, December). Deontological Ethics. Retrieved at April 14, 2014 from <http://plato.stanford.edu/entries/ethics-deontological/>

Goodwin, J.N., Shoulders, C.W. (2013). The future of meat: A qualitative analysis of cultured meat media coverage. *Meat Science*, 95(3), 445-450.

Hopkins, P.D., Dacey, A. (2008). Vegetarian Meat: Could Technology Save Animals and Satisfy Meat Eaters? *Journal of Agricultural and Environmental Ethics* 21(6), 579-596.

Miller, J.(2013). In Vitro Meat: Power, Authenticity and Vegetarianism. *Journal for critical animal studies*, 10(4), 41-63

People for the Ethical Treatment of Animals (2011). Meat contamination. Retrieved at April 14, 2014 from Peta.org: <http://www.peta.org/living/food/meat-contamination/>

Tuson, Harriet (2011, December). In vitro meat. Retrieved April 14, 2014, from <http://www.experimentation-online.co.uk/article.php?id=1170>

[experimentation-online.co.uk/article.php?id=1170](http://www.experimentation-online.co.uk/article.php?id=1170)

Van der Weele, C. (December 2010). In-vitrovlees: Yuck!(?). Wageningen: LEI.

Van der Weele, C. & Driessen, C. (2013). Emerging Profiles for Cultured Meat; Ethics through and as Design. *Animals*, 647-662.

Zimmerman, M. J. (2010, December). Intrinsic vs extrinsic value. Retrieved at April 14, 2014 from <http://plato.stanford.edu/entries/value-intrinsic-extrinsic/>

# We are what we eat

## Food or 'strange techno-meat'?

---

We might be able to produce in vitro meat technically, but will we consider it food, or disgusting? And what is the meaning of 'food'?

---

We have always loved meat and over time we found ways to make the source of our meat, animals, harmless, helpful, bountiful, and extra meaty. We learned how to feed them more efficiently for less, but our tasty meat still comes with costs and that sucks. What if it did not have to be so complicated? What if we could just grow meat? In vitro meat can help to find a way to grow meat without death, in a clean and safe environment. We have the same meat, but a different process (New Harvest, 2014).

This sounds nice, but do humans really want this meat? What does it mean for us, human beings, to eat meat, and will we accept the change of meaning by the introduction of in vitro meat?

Before we know whether people will accept in vitro meat as a 'normal' product, we have to understand the way humans see their food and especially meat. Meat has a particular meaning for humanity, which will probably change with the introduction and consumption of in vitro meat. Only a few philosophers have analyzed food. Food is vexing and it is not clear what it really is. It involves so much, such as vegetables, livestock, production, chemistry and more (Kaplan, 2012). However consumers will have some conception of what food is, and what

food is not, whenever we eat something: these conceptions will depend on aspects like health, environment, and economy. Among philosophers there is no consensus about the nature of food, although there are some thoughts like food as nutrition, as nature, as culture, as social good, as spirituality, as desideratum, or as an aesthetic object. What food really is will also depend on the way someone perceives it (Kaplan, 2012). However, the meaning of food is definitely not set in stone. The nutritional value of meat has always been important, but for example cultural aspects have changed and emerged since the prehistoric, and so have our eating habits.

Nowadays our eating habits have changed, due to changing food sources and possibilities for food commerce. This was mentioned by Henk Haagsman: "In our country we were not used to certain products. Now we eat kiwi and blue cheese, and we have changed our habits for food consumption a lot. [...] Take for example the first time people made beer, they also said 'I don't like it, with the use of yeast and so on'. Now people drink beer" (Haagsman, 2014). Eating habits and the meaning of food can go hand in hand and co-evolve. For some eating meat can have a ceremonial or symbolic meaning, for others it can involve respect and appreciation of



### Yeast-meat

Each 80-220 minutes yeast cells divide, comparing with animal cell this can be an advantage for the duration of the growth process. Yeast cells grow much and much faster than animal cells! Besides this the circumstances to grow yeast are easier, which in total can be a huge advantage for the whole growing process of in vitro meat. So why do we not make 'yeast in vitro meat'? However it is possible, the idea people have with yeast is probably even more YUCK! Compared with the responses to in vitro meat, the reaction to yeast-meat will be more negative (Jorgensen et al., 2002).

Figure 15. Yeast cells (*Kunkel, 2004*)

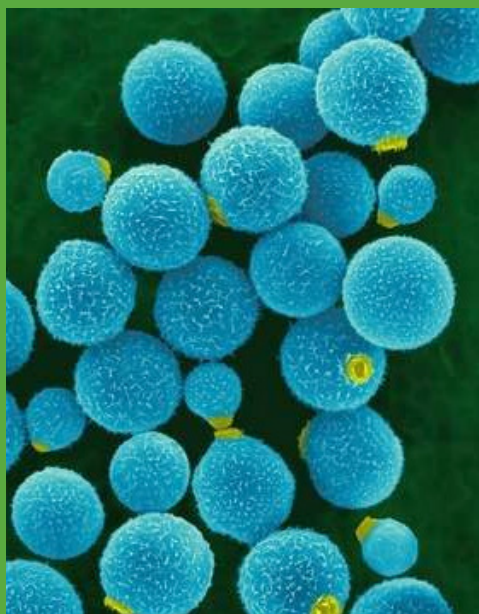

nature's bounty. Also other habits among meat like preparation, cooking, and hunting animals will be involved within the meaning of meat (Kaplan, 2012).

When it then comes to in vitro meat, we can analyze if food values can change so that in vitro meat will become acceptable food, rather than 'strange techno-meat', because the meaning of in vitro meat is definitely not the same as the meaning of 'normal' meat. Currently only nutrition and appearance are shared between in vitro meat and 'normal' meat. These are important values, but on the other hand in vitro meat is culturally void: it is not associated with traditions, cuisines or spirituality and it is considered very unnatural; and these are not all the differences, others will be discussed further on. But, as said above, what meaning people look for in food can change, and also the meaning of in vitro meat can change. In general there are several factors that will play a role in convincing people to eat something new (Neumark-Sztainer, 1999). To begin, we all have an image of products, which is always influenced. An image or idea over some products can change, but people have to be convinced before they believe. Thereby people need to have the sense of urgency to eat the 'best' products. Belief can be created with the use of media and marketing, which is also an important factor for the introduction of in vitro meat (see article page 32). With the use of nice campaigns, social norms can be changed and 'healthy' food can be seen as "cool" (Neumark-Sztainer, 1999).

For in vitro meat as a new product specifically, Henk Haagsman said: "It will take some time [before people accept in vitro meat as food]" (Haagsman, 2014). If it will take some time, people can get used to the idea of in vitro meat, and get familiar with the product. So even if the 'new' meat comes with changes in meaning, which it will, the time span can possibly help

in the acceptance. For example, the meaning of food as natural or social good will change if there is no 'real' animal involved (Kaplan, 2012). Although for some people it is hard to accept new products, others will see a new product, like in vitro meat, as very welcome. They say that the way food is produced in the last century is wasteful and unnecessary. To improve it we have to embrace food technologies, such as nutrient addition techniques, biotechnological processes, and possibly the production of in vitro meat. We can improve our foods over their natural forms, which will have an impact on the healthiness and quality of the products (SXSX Schedule, 2014).

As mentioned, over time all kinds of new products, like kiwi, blue cheese and beer, are introduced into our society. Aspects like taste, nutrition, costs, and other personal choices play an important role in the acceptance of a new product. The role of these aspects will differ between individuals and choices are related to someone's (healthy) lifestyle (Glanz, 1998). Furthermore, these aspects can be used to predict eating behaviors. If we want to know something about the changing meaning of in vitro meat, we cannot predict this only with the past in our head, where meat was very important. It is probably just as important nowadays, with the meanings of appreciation of nature and symbolic meanings as mentioned before. Meat has a key role in most meals, but finds also rich heritage of cultures and religious traditions (Kaplan, 2012).

Another important factor in the acceptance of in vitro meat is that social norms are different among countries and cultures, even if those are close to each other. These differences are very important to take into account when we talk about eating habits. Your family, religion, and culture of the country where you live, will influence your food consumption and your taste (Neumark-Sztainer, 1999). Take for example China, where eating

snake-meat is normal, which is a disgusting idea for most Europeans. In the interview with Cor van der Weele, we spoke about the different position over meat between Greece and the Netherlands. “One of the underlying differences between Greece and for example the Netherlands is that the gap between animals and humans, in North-West Europe, has been narrowed. So people became more sensitive towards animals and animals are more like us. That gap is probably wider in Greece and well that is probably one of the causes for the differences” (Weele, 2014).

If we take a closer look at Greece, there are people who have their own animals, mostly in the small villages. In the Netherlands the consumers do not have this kind of connection with their food. Due to this connection the meaning can change, for instance according to nature’s bounty. With the introduction of in vitro meat, the whole idea of meat changes as Cor van der Weele mentions: “It has a lot to do with the idea of meat, at least in the West. Our food is too industrial, we are too alienated from it, and we do not know where our food comes from.” However she did research on this idea and how it can change, with scenarios like urban farming, ‘the pig in the backyard’ (see article at page 54). Within this scenario “suddenly people no longer saw it as so unnatural or alienating. If we have a closer relation with the source of our food, then it is associated with all kind of things like naturalness and authenticity and so on” (Weele, 2014). This is the same for some people in the Netherlands right now: they want to know how their food is produced. Most citizens do not have their own animals, but some grow vegetables in their backyard or a small field somewhere else.

The case is still that only a small part of the world population is conscious about their food and eating habits. So the question is: ‘Are we ready for in vitro meat’, which is hard to answer right now. People see it as something grown in a lab, which is only technological and not natural. However, “you can choose for how people will experience things. It will make a difference how in vitro meat is produced, whether it is produced in big factories, or small factories associated with urban farming or something” (Weele, 2014). The issue is that right now in vitro meat is not following normal consumer trends (Vlees.nl, 2013). Consumer trends are involved with all different aspects of food, what fits within the cultural life style, and the meaning we describe to our eating habits. As described by Kaplan, food can have different meanings, and values, for example the meaning according to appreciation of nature and the value within culture and symbolic meaning, are important. With the consumption of in vitro meat these meanings are probably not the same. However, if in vitro meat is seen as a product directly from nature we will regard it more as food.

With humanity’s eating habits the role of lifestyle has an influence on the meaning of meat. There are different thoughts among human beings about meat, such as ‘tasty’, ‘harmful to animals’, ‘important source of food’, ‘unhealthy’, and more. Taking these thoughts in mind, some consumers will probably be enthusiastic, and encourage the change of meat to another ‘healthier’ product, possibly something like in vitro meat. Other consumers really ‘love’ meat and the taste of it. For these people the change in meaning is more difficult, and can take more time. They probably do not consider in vitro meat as a natural product. Besides marketing, it can be possibly helpful when in vitro meat tries to mimic ‘normal’ meat. What is actually what researchers want to accomplish; technological researchers have reached the same conclusion, which is why they aim at producing meat that is really close to ‘normal’ meat. Right now we have the option for meat substitutes, and still the largest part of the population chooses for real steak, real chicken, or real pork belly. Humans do not consider these substitutes as meat, and most still have a particular meaning of meat and really likes to eat it (Decker & Park, 2010). It is the question whether in vitro meat will be different from these substitutes.

The question is then whether we want exactly the same as ‘normal’ meat? In vitro meat can be produced as a different product, or do people want something totally different, like meat made from vegetables, or maybe from yeast (see sidebox)? With the comparison to meat substitutes it is possible that in vitro meat has a chance to make it into the market. For meat eaters it is probably easier to accept a change from meat to a substitute that is really similar, like in vitro meat. Whether we will accept in vitro meat depends on different factors. For instance cultural differences can cause a difference in meaning and thereby acceptance. Food habits change over time, so with that the positive and negative reactions towards in vitro meat can

#### Celebrity-meat

Do you want to taste Johnny Depp, Nicole Kidman, Obama, or everyone else you like? It is possible and it all just starts with tissue samples. You can order your favourite celebrity, his or her tissue will be used to grow into a flavourful salami. Celebrity meat sounds fake, what it is right now, but it can become reality with the techniques of in vitro meat production. Will we become cannibals? About human meat Cor van der Weele says: “I think that if everything works as it is meant to work, you only need some cells, so the same can be done from a human being, why not?” (Bitelabs, 2014; Weele, 2014)

increase and decrease. The meaning of food depends on different factors and changes all time, which can lead to the acceptance of new products, like in vitro meat. In vitro meat has different meanings, which means that it caters to some people who are in favor, but not to others who choose to eat 'normal' meat or meat substitutes.

Author: Karin van Leersum

## Sources

Bitelabs. (2012). Eat celebrity meat. Retrieved April 3, 2014, from Bitelabs: <http://bitelabs.org/>

Decker, E. A. & Park, Y. (2010, April 15). Healthier meat products as functional foods. *Meat Science*. Vol. 86, pp 49-55.

Glanz, Karen et al. (1998, October). Why Americans eat what they do: taste, nutrition, cost, convenience, and weight control concerns as influences on food consumption. *Journal of the American Dietetic Association*. 95(10): pp. 1118-1126.

Haagsman, Henk. (2014, February 14) Interview on technological aspects of in vitro meat.

Jorgenson, Paul et al. (2002). Systematic identification of pathways that couple growth and division of yeast. *Science*. 297, 395. DOI: 10.1126/science.1070850

Kaplan, D.M. (2012). *The Philosophy of Food*. University of California press. Retrieved April 14, 2014, from The philosophy of food project: <http://www.food.unt.edu/philfood/#b>

Neumark-Sztainer, Dianne et al. (1999, August). Factors influencing food choices of adolescents: Findings from focus-group discussions with adolescents. *Journal of the American Dietetic Association*. 99(8): pp. 929-937.

New Harvest. (2014, March 25). Same Meat. Retrieved March 26, 2014, from New Harvest: <http://www.new-harvest.org/>

SXSW Schedule. (2014, March 9). The future of food processing. Retrieved March 28, 2014, from SXSW Schedule: [http://schedule.sxsw.com/2014/events/event\\_IAP26945](http://schedule.sxsw.com/2014/events/event_IAP26945)

Vlees.nl. (2013, August 5). 'Kweekvlees' levert kennis, maar is niet marktrijp. Retrieved April 1, 2014, from Vlees.nl: <http://www.vlees.nl/algemeen/nieuws/bericht/alles-over-kweekvlees/>

Van der Weele, Cor. (2014, February 27). Interview about the ethical aspects around in vitro meat.

# Liberating the livestock

## In vitro meat and the relation between mankind and the animal

---

Animals are everywhere. But, when the source of meat shifts from farm to biofactory, this will change, and so will our relation with animals.

---

In classical philosophy, humans and animals were already seen as part of the same kingdom, humans being “featherless bipeds with broad flat nails” as Plato stated it. If humans are animals, then we have not always been as kind to our fellows: Throughout the millennia, humans have dominated the other animals to be able to feed, dress and protect themselves. Meat has in general always been seen as a human need and billions of animals have been killed because of this. To gain meat from these animals, an equal relation between man and animal seems untenable: if we want to kill animals for our own needs, we automatically see those animals as a lower species than our own. Philosopher on animal rights Gary L. Francione argued that this has led to a moral schizophrenia: on the one hand most (American) people indicate that they value animals just as humans and think their rights for freedom are just as important; on the other hand we use all these billions of animals to feed our own needs, and not even the basic needs, eating more meat than strictly necessary and using fur in times when there are more than enough synthetic alternatives (Francione, 2004).

The different relations with animals show themselves in farmer-animal relations, for which Wilkie (2005), developed a framework. She distinguished four types of relations between

farmers and livestock: concerned detachment in which the relation is impersonal and indifferent; concerned attachment in which the relation between human and animal is more personal and the animals are seen as individuals; attached attachment in which the animals almost get a pet-status; and detached detachment in which the animals are only seen as a commodity.

Wilkie argues that farmers that handle animals for slaughter mostly show a concerned detachment relation, while those involved in breeding or other situations in which the farmers are more involved with the animals in general have a concerned attachment relation. This seems a natural thing, since it seems easier to not see cows as individuals when one has to slaughter them in the near future. This can also be seen in how the animals with different uses are treated different: farmers care more about their animals physical and mental state if they use them for milking (for example) than if they will be killed for their meat. This for instance shows itself in the animal food, which is often of higher quality for the animals who will be giving dairy during their lifetimes, and even in naming: as a farmer indicated, she gave all of her milk cows individual names, while the pigs used for meat were all simply named ‘Jansen’. This difference in attitude towards animals that

are different in use is interesting in light of the introduction of in vitro meat. If in vitro meat is introduced and accepted by the world in general as a (cheaper) replacement for the meat which is made directly from dead animals, this can have an impact on the way we view animals. To see change, we should assume that other products for which animals have to be killed, such as fur and leather, will be replaced by their synthetic alternatives which are already viable and used on large scale. With these developments, killing animals is not a necessity anymore for gaining any of products we need. In that sense, the relation we have to the animals already changes since their death does not lead to direct resources for mankind. Farm animals will still be kept, but only for the production of milk and eggs for example.

As discussed, farmers have different relations with these animals they do not kill. To think further of this, we could see similar implications for humanity's feeling as a whole towards farm animals. If cows, pigs and chicken are not killed for our needs anymore, we could see them in a different perspective. As Rosalind Hursthouse, moral philosopher, said after she turned vegetarian: "I began to see both the wild ones and the ones we usually eat as having lives of their own" (Hursthouse, 2000, 165–166). If we do not have to kill animals, gaining their products as humans could be regarded as a kind of barter relationship: 'we' give 'them' food and shelter, they give us their products.

Interesting for comparison is the relation mankind (in the Western world) has with dogs. This relationship started from purely practical interests: dogs were used for tracking and herding. As these functions have become less and less essential, bonding seems to have become the most important aspect of the dog-human relation. With cats a similar development has taken place in the last century, transforming them from animals that were kept outside the house to hunt mice and vermin to pets that are even allowed to sleep in the bedroom.

Cows and pigs becoming pet animals seems a little farfetched, but a similar development as that with dogs seems not. Thus in that sense, the relation becomes different in that animals become more of individuals. To come back to Francione's concept of moral schizophrenia: the two parallel but opposite relations mankind has with animals kind in this way could tip to the caring side. It is hard to make concrete predictions, but this change in attitude towards animals can also change how people regard animal rights and animal-related issues in general. We will see the impact of this in the future but it seems in this way that in vitro meat might in this way solve an internal struggle people might have in their attitude towards animals as opposed to their meat consumer behavior. For now it seems that after in vitro

meat becomes the supermarket standard, parents might at least have less mixed feelings when their child is admiring the loveliness of the cows and pigs in a farmer's meadow.

Author: Wouter Versluijs

## Sources

Anderson, R. K. (2007, May 20). The Changing Status of Animals and Human-Animal Bonds. Retrieved March 6, 2014, Censhare University of Minnesota: <http://censhare.umn.edu/spotlight02.html>

Bock, B. B., Van Huik, M. M., Prutzer, M., Eveillard, F. K. & Dockes, A. (2007). Farmers' relationship with different animals. *International Journal of Sociology of Agriculture and Food*, 15(3), 108-125.

Francione, G. L. (2004). *Animals--Property or Persons?*

Hursthouse, R. (2000). *Ethics, Humans and Other Animals*. London. Routledge.

Wilkie, R. (2005). Sentient commodities and productive paradoxes: the ambiguous nature of human-livestock relations in Northeast Scotland. *Journal of Rural Studies*, 21(2), 213-230.

# The technological fix

## Heidegger's deontological argument against in vitro meat

---

Heidegger is considered a typical armchair philosopher, but in a public debate on in vitro meat his philosophy becomes applicable.

---

In an online discussion on in vitro meat on the website of the The Guardian (see section on the next page), a group uses an interesting argument to oppose in vitro meat. They accuse proponents of in vitro meat in this online discussion that they refuse to consider different options, but rather opt for the 'technological fix' to problems with our current meat production. In this article, we will analyze this argument and see how Martin Heidegger's philosophy of technology adds philosophical depth to the 'technological fix' argument and subsequently look at what Heidegger's views might have been on in vitro meat.

But first, an introduction into Heidegger's philosophy. He concerns himself with what he calls the question of being: the philosophical subject called ontology. In what way do we exist in the world? This might be an odd question to ask, especially in the context of in vitro meat, but it lies at the basis of a deep implication for in vitro meat, and all kinds of technology. When Heidegger looks at this philosophical subject of ontology, he identifies that technology plays an important role in how we exist in the world. In 1954 he wrote the book *Die Frage nach der Technik*, the Question concerning Technology, where he addresses two things of importance to us: what the essence of technology is, and how it influences us. Heidegger has a rather unusual perspective on these two concepts. Ordinarily we

think that the most important trait of technology, the essence, is that it is a tool, something that we pick up and use for a specific goal that we set out in our minds, and then when we have realized that goal, we stop using it and that's it. A car is used for driving somewhere, and when we have arrived at our destination, the car is just a car sitting in the parking place.

This is not the view that Heidegger and many other philosophers of technology have of technology; he has a radically different view on the essence of technology. In the tool-view of technology, the technology doesn't influence us at all, but this view is incorrect: technology influences us extensively, whether we are using it or not. Technology is not neutral, but forces certain behavioral pattern and ways of thinking, consciously or subconsciously. For example, a car is not just a tool for driving, but plants in your mind the idea that the world can be travelled easily, that roads should be built for your convenience, to allow the car to be driven. When we have cars, plains become an ideal spot for a crossroad, and a mountain a challenge to be overcome by a building a mountain pass road, or perhaps by a Land Rover. This is how Heidegger views the essence of technology and how it influences us. A hammer is a tool, of course, but it's not just used for hammering nails. When you have a hammer, you see new things that you can hammer, destroy or unhinge, that you wouldn't have considered before. In the same way cars

open up new possibilities to us. The 'opening up of new possibilities' is really the essence of technology for Heidegger: it reveals to us new ways of seeing and thinking about the world. The essence is the way in which it influences us, so the two concepts are really tied together strongly. This is also why technology is important for the question of being: the world is different to us if we use technology, and our existence, our lives, change because of technology. It is really important for Heidegger that one realizes that technology is not a simple tool, but rather something that has a strong impact on how we think.

Now that we know Heidegger's essence of technology, let's look at in vitro meat. We can analyze the technology using Heidegger's framework, even though the technology doesn't really exist at the moment. But it will be more interesting first to look at how we think about the world without in vitro meat, and then later analyze the differences. A world without in vitro meat factories has other things that produce meat. What are these other meat producing things, you might ask, and the answer would be: livestock. Surely cows, chickens and pigs are not things, but if we compare in vitro meat and livestock side by side, something rather strange occurs. In the article on environmental impact in this magazine (page 23), in vitro meat and livestock are directly compared as if they were two rivaling technologies, and this practice is of course very common in technical papers. When compared in this way, clearly in vitro meat is the more efficient technology: it produces less greenhouse gasses, requires less energy and less water, and so on. Furthermore, livestock suffers from dangerous diseases that really make it a terribly inefficient

meat factory. The only problem is, animals are not technology. In vitro meat made us think of them as if they were technologies, and this is yet another example of how technology influences how we see the world. This is called the technological way of thinking (about the world).

Heidegger would not argue that in vitro meat has led us to see livestock as an inefficient technology. This would be impossible, since in vitro meat barely exists, and we know of the environmental problems with livestock for quite some years. Rather he wants to show that all modern technology that exists so far has influenced our way of thinking in such a way that we, unknowingly, give technological answers to questions that have other, non-technological answers, such as: "How do we solve the problems with our food production?" To this question, in vitro meat is the technological answer. This leads some to claim that 'we can do better than nature': the technological view of non-technological entities is the distinct framework that Heidegger points out; he calls it *das Gestell*: the technological way of thinking.

In the technological way of thinking (as if everything were some kind of technology) lies the real objection that Heidegger would make to in vitro meat. In vitro meat is a very modern technology, and modern technology is problematic; it is different from traditional technology: it also reveals, but reveals the world to us as a resource. A shovel would not make you think of the Alps as a good location for a road, but modern technologies such as advanced tunnel drills and mechanized excavators do. And, as illustrated earlier, modern technology shows a cow as an inefficient meat resource, or rather: our technological thinking in

### The public debate and science communication.

Science communication is an academic field that is concerned with studying how science-related topics are brought to the non-expert public and how this public uses these topics and relates to experts. Although this field belongs to the social sciences, it is discussed here because it directly applies to the debate, which is used to support a philosophical perspective.

Because in vitro meat is a very 'scientific' product, it has caught the attention of science communication studies to examine how the public addresses the issues this potential future product raises. We have interviewed professor in science communication Hedwig te Molder who has been concerned with in vitro meat in a graduation project. For this project, the reactions to and discussion of in vitro meat were studied on the website of the Guardian, an English newspaper. Discourse analysis was used to study the implicit norms that drive arguments in the debate. One of the most important things in the debates on in vitro meat is the identity that people take when they argue either for or against it. Who is the responsible consumer and who is the spokesman of the future? Most stances in the debate argue that they fit these identities, for completely different reasons. From the analyses of the debates on the Guardian website, roughly two 'extreme' stances could be distinguished: those arguing that in vitro meat is a technological fix, a form of moral cowardice, and thus not really the good thing to do, and those arguing that a moral flexible stance should be taken, seeing in vitro meat as a good-enough solution and that it is better than no change at all. The argument of moral cowardice has been mentioned before in this magazine, and it is interesting to see how it is not only a purely philosophical argument, endorsed amongst others by Heidegger's philosophy, but also an argument that is actually used in practice: in vitro meat contestants argue it is not the real solution to a problem, but only covers some of the symptoms of the problem.

das Gestell reduces traditional agriculture to food factories, hills to coal deposits and rivers to water highways. Modern technology influences us very strongly in this way, and Heidegger fears that a human being whose surroundings are saturated with modern technology is unable to think in a non-technological way. Living animals, which provide us with food, but also companionship, the view of lovely grazing meadows and other products such as leather shouldn't be replaced by a modern technology, Heidegger would say, as this contributes to our already overly technological surroundings, which may lead to an inability to think differently about our existence: hence the existential crisis. Heidegger's greatest fear is that we are unable to get out of the technological way of thinking. Too much modern technology and we will ultimately be limited in our ways of being with no way out. Once livestock really is the inefficient meat factory to us and nothing more, we will never be able to return to other ways of thinking about livestock, and that is tragic. This is why Martin Heidegger would oppose the technology of in vitro meat. He doesn't want to say that one way of thinking is best, but that the technological way of thinking is the worst. The best way of being would be a way here we are not committed to one way of thinking (which he calls 'Gelassenheit', releasment), and in vitro meat, as a modern technology, commits us to that technological way of thinking, and therefore we should stay away from it.

We can now see how Heidegger's philosophy offers a deep and grounded argument for the 'technological fix' public discourse over in vitro meat. In vitro meat is problematic because it is a 'technological fix' to a problem that is not entirely technological. The problems that our (excessive) meat consumption causes can be addressed in different ways: consume less, become vegetarian and treat animals more humane. To some people in the discussion on TheGuardian, in vitro meat is yet another refusal to make significant existential choices. It is a technology that is a short-sighted solution and yet another commitment to modern technology. In the debate, this position is often supplemented with moral arguments for other solutions that Heidegger wouldn't have preference for, but he does condone that they steer away from a technological solution.

Modern technology has a significant impact on our understanding of the traditional livestock. It is quite possible that, in the future, we might see a grazing meadow in the mountain and be only able to see the cows on it as inefficient machines and nothing else, wasting valuable space and resources. The non-technological views of livestock is an understanding that should not be lost, and while in vitro meat is only a small factor in the dangerous pit that is das Gestell, it is one nonetheless. Despite Heidegger's concerns, modern technology has continued to intrude in our existence, force away other ways of thinking, and now we are on the brink of letting yet another technology into our lives to replace something as fundamental as our livestock. Perhaps Heidegger's philosophy is here to show us that in vitro meat technology is not the perfect solution, and that we should strongly consider

other options and answers before going for the easy 'technological fix'.

Author: Joris Luyt

#### Sources

Driessen, Korthals (2012). Pig towers and in vitro meat: disclosing moral worlds by design. *Social Studies of Science* 2012 42:797-820

Hedwig te Molder, (2014). Interview concerning in vitro meat.

Heidegger, M. (1954). *Die Frage nach der Technik*









**TwentePAM**  
From a philosopher's perspective

APRIL 2014  
FIRST EDITION

Enschede  
University of Twente



## An editor's note

---

Competing in the Academic Year Prize 2013, has professor Steenbergen and his project TwentePAM, resulted in winning the audience award. Unfortunately losing the €100.000 grant, left prof. Steenbergen with some public awareness of the phenomenon photoacoustic imaging and the chance to formulate a question for the “*Nederlandse Wetenschaps Quiz 2013*” as consolation.

As unsatisfying as this may have been for Steenbergen and his teammates, they had no other option but to continue their search for money to fund their dream project. Adequate funding has been problematic over the years, companies as well as institutions are not that willing to fund the necessary amount of money, especially not in the current stage of the project. The research group is now at the point of entering stage 2 clinical trials, for which a lot of money is needed. Hopefully, phases 2 clinical trials will provide proof that the TwentePAM2 is more sensitive, specific, and accurate than current breast cancer screening devices, and possibly change the current breast cancer screening programs. In addition to the accuracy of TwentePAM2, its costs are also a very important aspect to take into account, for it to gain entrance into the medical world and get established. The price-quality ratio should also be better for TwentePAM2 than for X-ray mammography.

These aspects can be improved fairly easily if money is available to do research, but satisfying the socio-economic conditions of the technology is difficult. An interview with assistant professor dr. M. Boenink, expert in philosophy and ethics of biomedical technology, revealed that in order for TwentePAM to be accepted in the clinical environment for use, not only should aspects addressed in Health Technology Assessments (HTA) be met, but also meeting socio-economic demands is important, since it helps to show how TwentePAM can contribute to society if it promotes itself as a responsible innovation.

A very important question to answer in such research is on the desirability of the technology. If there is no public support, then it might be increasingly difficult to get the technology in a clinical environment. Participating in the Academic Year Prize raised more public awareness for the scientific basis of the technology, and clinical trials together with Analytic Hierarchy Process as a HTA should help in evaluating the social and clinical implications and clinical benefit of TwentePAM.

In this magazine, we evaluate several aspects of the innovation process TwentePAM is going through, in order to come up with useful recommendations for prof. Steenbergen on the next step to take towards success.

RYANNE DE BOER



# Contents

An editor's note .....	63
Introduction .....	67
Breast cancer screening: Current status .....	68
Current techniques: Ultrasound and Mammography .....	72
From fundamental science to the application .....	74
The four steps in PAM1 .....	76
To the future: PAM2 and beyond .....	78
What can we expect from TwentePAM? .....	79
What is holding the TwentePAM back? .....	82
From scientific research and technological development to a better product for the clinic .....	85
Reading the big boys' minds .....	87
A peep into innovation processes in science and technology .....	89
Conducting research with a tight budget .....	95
Surviving the Medical Valley of Death .....	99
The X-ray mammography .....	99
Breast cancer controversy .....	101
Responsible Innovation .....	103
Recommendations .....	105





# Introduction

---

RYANNE DE BOER

Breast cancer is the second most common form of cancer in the world, responsible for 25% of all cancer diagnoses. The incidence rates vary widely among the world's regions but breast cancer remains the most common cancer affecting women all over the world. Mortality rates are fairly equal around the world; more developed regions have lower mortality ratios compared to less developed regions. These statements indicate that breast cancer business is a matter of serious concern.<sup>1</sup>

The high incidence of breast cancer demands that there is continuous research going on in searching for the best possible diagnostic device, and for the best possible treatment. MRI and breast ultrasound are mentioned as advanced devices used in the detection of early stage breast tumours in population screening, and in screening women with higher cancer risk. Comparisons made between these relatively new imaging methods and the more conventional X-ray mammography shows that besides the needed enhanced tumour detection, there is also an increment in false positives following screening.<sup>2</sup> Photo-acoustic imaging combined with ultrasound detection developed in the University of Twente is a new technological development designed for use in breast cancer screening. It combines the advantages of high contrast imaging resulting from optical techniques, with high-resolution ultrasound imaging.<sup>3</sup> This needs to be evaluated further since the technology seems to have a higher specificity towards tumour detection than conventional screening technologies.

Socio-economic factors play an important role in the stabilization of the technology. Money is a key factor and funding is hard to get. This is one of the reasons the research group from University of Twente has competed in the Dutch Academic Year Award 2013 to gain money for the project and awareness of the significance of the development. Under the slogan "You can hear your tumours" they competed with other scientific projects for a price of €100.000 to use in further research. Although the team PAM won the Audience Award, they lost the €100.000 price.<sup>4</sup> With the Twente Photo-Acoustic Mammography (TwentePAM), breast cancer screening will be more precise and thus find smaller tumours, compared to conventional X-ray mammography. It is also less painful, because the breast of the patient is not firmly compressed during the examination.

By detecting smaller tumours better than conventional X-ray mammography can do, the TwentePAM appears to be a very promising technology for breast cancer screening and detection. Why then is the technology not used yet, what are the flaws that make it difficult to get funding for further research? Maybe society needs to be more informed and educated about the possibilities of the technology, or the technique is time consuming compared with conventional X-ray mammography. The aim of this magazine is to take a closer look at the development of the technology, how it influences society, and what its role is (and will be) in breast cancer, breast cancer research, and use in society.

## References

- <sup>1</sup> Ferlay J, Soerjomataram I, Ervik M, Dikshit R, Eser S, Mathers C, Rebelo M, Parkin DM, Forman D, Bray, F. (2013). Incidence/mortality data. *GLOBOCAN 2012 v1.0, Cancer Incidence and Mortality Worldwide: IARC CancerBase No. 11 (Internet)*. Lyon, France: International Agency for Research on Cancer. Retrieved from [http://globocan.iarc.fr/Pages/fact\\_sheets\\_cancer.aspx](http://globocan.iarc.fr/Pages/fact_sheets_cancer.aspx)
- <sup>2</sup> Houssami, N., & Ciatto, S. (2011). The evolving role of new imaging methods in breast screening. *Preventive Medicine*, 53(3), 123-6. doi:10.1016/j.ypmed.2011.05.003
- <sup>3</sup> Jose, J., Manohar, S., Kolkman, R. G. M., Steenbergen, W., & van Leeuwen, T. G. (2009). Imaging of tumor vasculature using Twente photoacoustic systems. *Journal of Biophotonics*, 2(12), 701-17. doi:10.1002/jbio.200910025
- <sup>4</sup> Academic Year Price 2013. (2013). Retrieved from <http://www.academischejaarprijs.nl/2013/11/06/staatssecretaris-sander-dekker-reikt-academische-jaarprijs-ter-waarde-van-100-000-euro-uit-aan-team-shamoun-baranes/>

# Breast cancer screening: Current status

---

RYANNE DE BOER

Breast cancer is a very common type of cancer among women, making adequate and sensitive screening of high importance. In the Netherlands, breast cancer screening is aimed at screening all women over 50 years once every two years, until they turn 76. By using an X-ray mammography examination, lesions in breast that are (not yet) palpable can be detected, which allows early detection of potential malign breast cancer. Early detection of breast cancer increases the survival rate of the affected women, which speaks in favour of screening women intensively, and of improving the sensitivity and specificity of the available screening techniques.<sup>1</sup>

X-ray mammography is the screening technique used in the Netherlands for screening (and hopefully early stage detection) of breast cancer. The technique detects spots with higher density than the surroundings, which can indicate a tumour. A sign of abnormal breast tissue does not necessarily mean breast cancer diagnosis. Cysts, calcifications, and benign lumps are also common besides tumours, however, those malformations are usually not dangerous. Malign or aggressively growing tumours can be dangerous and are difficult to differentiate from benign tumours by X-ray mammography making additional ultrasound, MRI, and/or biopsy necessary.

Mammography is an X-ray based technique, which has both cancer detecting characteristics and damaging characteristics. Frequent scans using X-ray can cause the frequently screened cells to mutate causing tumours to grow. Mammography has also difficulty in detecting malformations in dense, or young, breasts. Besides this, the procedure is rather painful since the breasts have to be compressed between two plates to allow the device to take photos from different angles. A general X-ray mammography screening is held in the screening buses every other year for women between age 50 and 75, takes photos of the entire breast in the Netherlands.

---

**Cysts** are fluid filled sacs, usually well edged and round/oval of shape. Cysts are usually not malign, therefore not dangerous, and does not have to be removed. When the cyst is painful, or otherwise uncomfortable, the fluid can be drained to ease the symptoms.

---

**Calcifications** are calcium sediments in breast tissue, an visible on X-ray images as white dots or specks, depending on their size. The larger spots are usually non-dangerous, while smaller specks might show a potential cancerous pattern. Suspicious calcifications require follow up testing, with US and biopsy.

---

**Angiogenesis** is necessary for tumours to grow, for blood provides the cells with oxygen and nutrition, which are necessary in order to grow. Vessel formation is stimulated by a variety of peptides produced by tumour cells or inflammatory cells, and allows metastasis when bloodcells separate from the lump and infiltrate another part of the body.

---

Diagnostic screening, for women with palpable lumps, or for women with alarming X-ray photos from the general screening, is more focused on a specific lump or area of the breast.

In the Netherlands, 25/1000 women who go to the screening are referred and some of them undergo an extended procedure described in the next paragraph. In the numbers of actual diagnosed women, a distinction is made between women being referred after their first screening (age 50), and women being referred after several years of screening. In 2003, per every 1000 screened women, 25 were referred, of which 5 were diagnosed with breast cancer. In 2003, per every 1000 women who have been screened before, almost 12 were referred of which 4 were diagnosed with breast cancer. This

means that approximately 9 out of 1000 women over 50 years old are diagnosed with breast cancer.<sup>2</sup>

When a woman has suspicious X-ray mammography results from regular screening in the Netherlands, the woman is referred to the so-called 'Mammopoli' in a nearby hospital. Within the clinic, another mammography is made when necessary, followed by ultrasonic imaging of the suspicious lump.<sup>3</sup>

The ultrasound provides additional information to the information provided by the X-ray mammography images, who together will lead to the (correct) diagnosis of the lump by the radiologists. The radiologist can take a biopsy from the lump if that is necessary; sometimes the lump is a cysts, and in that case, it is not necessary to worry that much. A cyst can be emptied during the ultrasound session. The assessment of the lump by the radiologist is based on the experience the radiologist has gained over the years, combined with the knowledge on images gained during his/her education. The majority of suspicious images will also be discussed in a multidisciplinary meeting with several radiologists, mammacare nurses, oncologists, and other physicians. The biopsy taken allows the pathologist to take a look at the cells of the lump, determining what type of lump it is. The results coming from the pathologists tell the physician and the patient the most secure information about the lump. MRI is also

used for diagnostics, if the X-ray mammography and ultrasound do not provide enough information about the lump (which might be the case for women with dense breasts).

Breast density is a risk factor for breast cancer often associated with a four- to sixfold increase in developing breast cancer.<sup>5</sup> Since denser breasts decrease the diagnostic sensitivity of X-ray mammography, as figure 1 shows, it is more difficult for radiologists to differentiate between healthy (dense) breast tissue and tumour tissue in dense breasts.<sup>5</sup> When one compares figure 2a with figure 3 (all images X-ray mammography images), it is clear that in a more dense breast (figure 2b), it is more difficult to distinguish a tumour from surrounding dense breast tissue than it is to distinguish a tumour from its surrounding less dense tissue. Breast density is expected to decrease with an increase in age, making it easier to detect tumours in older women than in younger women.<sup>5</sup>

MRI as an imaging technique is better able to make this distinction in dense breasts which results in combining X-ray screening with MRI for women with dense breasts.<sup>5</sup> The downside of this combination are the costs: MRI is an expensive imaging technique, which makes it less favourable to use of screening. This does not mean that MRI should not be used for diagnostics; MRI is an excellent add-on if the X-ray mammography shows a suspicious breast.

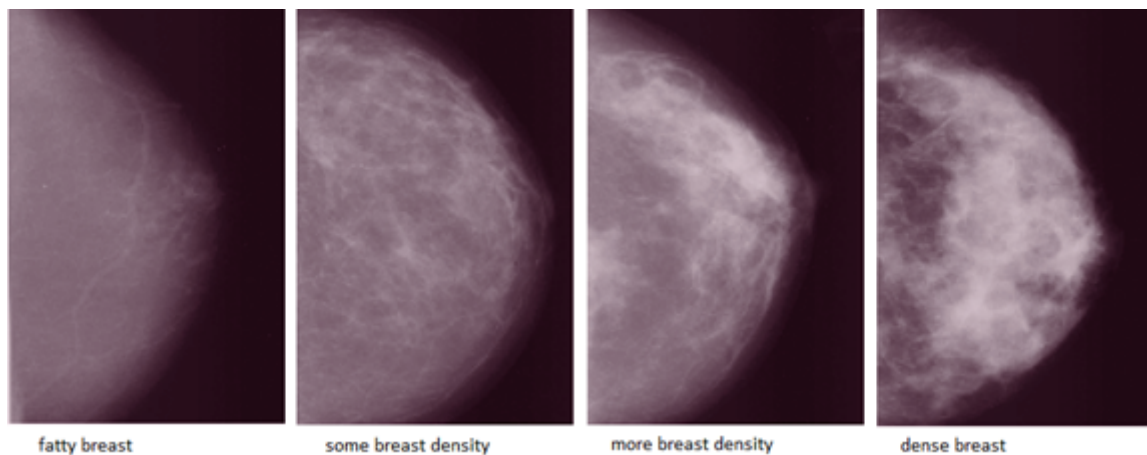

Figure 1: Retrieved from <sup>4</sup>

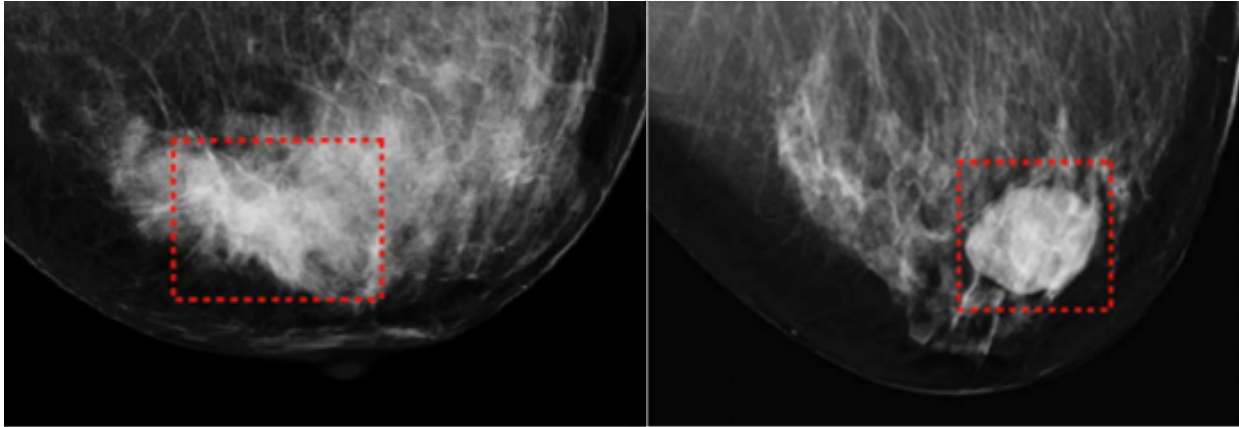

Figure 2: a<sup>7</sup> (left) and b (right)<sup>7</sup>

The X-ray screening mammography is still widely used in the midst of critique. The age restriction for the screening includes only women over 50 years old. While breast cancer is more common among women over 50 years old, this does not mean that women of lesser age do not get breast cancer. Because of excluding this group of women from the screening program, the percentage of women dying from breast cancer within this age group is higher than that of the screening group.<sup>1,6</sup> It is likely that this is because the types of breast cancer occurring in women of this age group, since it seems to be more aggressive; the survival rates are lower for women under 50 years old.<sup>6</sup> This could have to do with later detection of the tumour because of the women not being in the screening program, with menopause, or with the breast density.<sup>5</sup> Also, having a mutation as BRCA1 or BRCA2 genes increase the chance of getting breast cancer.<sup>6</sup> The false-positives and false-negatives that may result from screening cause stress by the affected women, since the screening X-ray photos predict a tumour, while this may not be the result of further research (MRI, ultrasound, biopsy). It can also occur the other way around, when the screening X-ray photo not shows anything to worry about, but the women later turns out to be the host

of a developed breast tumour. These false-positives and false-negatives are unwanted for their side effects, and together with the relatively high screening age for women<sup>1</sup>, a new screening technique - is desired, besides improvement of the current technique. Improvement of the current technique as well as a new screening technique is desired to lead to more sensitive and more specific images, increasing accuracy in diagnosing breast cancer.

---

**Malign tissue** represents a variety of illnesses, following from DNA damage by mutations. DNA damage causes the affected cells to grow exponentially for they mutate on genes responsible for cellcycli. Characteristic for malign tissue is the abnormal proliferation of cells, vascularization (angiogenesis), infiltration of neighbouring tissues, and changes in the characteristics of the proliferating cells themselves. The latter can be noticed by cytologists, after biopsy.

---

**Benign tissue** is a mass of fast growing cells, caused by DNA mutations. A mass is benign if it does not infiltrate other parts of the body, contrary to malign tissue.

---

#### References

<sup>1</sup> Interview with prof. dr. Steenberg, (2013, December 23)

<sup>2</sup> Lee, C. H., et al. (2010). Breast cancer screening with imaging: recommendations from the Society of Breast Imaging and the ACR on the use of mammography, breast MRI, breast ultrasound, and other technologies for the detection of clinically occult breast cancer. *J Am Coll Radiol* 7(1): 18-27.

<sup>3</sup> *Nederlands Huisartsen Genootschap* (2014, February 25). Standaard Diagnostiek van Mammacarcinoom.

<https://www.nhg.org/standaarden/volledig/nhg-standaard-diagnostiek-van-mammacarcinoom>

<sup>4</sup> Komen, S. G. (2011). Breast density. (2014, March 15) Retrieved from [www.komen.org/breastdensity](http://www.komen.org/breastdensity)

<sup>5</sup> Checka, C. M., et al. (2012). The relationship of mammographic density and age: implications for breast cancer screening. *AJR Am J Roentgenol* 198(3): W292-295.

<sup>6</sup> Anders, C. K., Johnson, R., Litton, J., & Phillips, M. (2009). Breast Cancer Before Age 40 Years. *Semin Oncol*, 36(3), 237-249. doi:10.1053/j.seminocol.2009.03.001.Breast

<sup>7</sup> Piras, D., Steenbergen, W., van Leeuwen, T. G., & Manohar, S. G. (2010). Photoacoustic Imaging of the Breast Using the Twente Photoacoustic Mammoscope: Present Status and Future Perspectives. *IEEE Journal of Selected Topics in Quantum Electronics*, 16(4), 730-739. doi:10.1109/JSTQE.2009.2034870

# Current techniques: Ultrasound and Mammography

RYANNE DE BOER, RUUD VAN LAAR

In ultrasound imaging, sound waves are sent into tissue via a transducer. A transducer is a device that translates one form of energy into another. In this case electrical energy is converted to pressure waves (kinetic energy) with the aid of piezo-electric materials. These sound waves are then reflected by the internal tissues and will be absorbed differently since all different types of tissue have a different density. The degree of absorption is dependent on the frequency of the sound waves: the higher the frequency, the higher the absorption. Following the absorption of the sound waves, reflection also occurs. This happens when the waves travel through different types of tissue who have different impedances. A difference in impedance between two media is the proposition for reflection of sound waves, and the portion of sound waves not transmitted nor absorbed by the medium, will be reflected to and detected by the same transducer that send the waves into the tissue. The reflected waves arrive at the transducers at different moments in time, creating an image of the structures under the transducer.<sup>1</sup>

In X-ray mammography, a similar principle is applied with light waves rather than pressure waves. The rays of light have such a high energy that they

are not in the visible area of light. This allows them to travel through the body. All different organs, fat tissue, and bones absorb X-ray at different levels so in an X-ray picture you can see how much x-rays have passed through the body at different positions in the body.<sup>2</sup>

When X-ray is used for mammography, the energy used is lower than general X-ray pictures because the waves do not have to travel through a complete body or through dense tissue as bones. Cancerous tissue is usually more dense than normal tissue, so these parts absorb more X-ray photons. On the other side of the breast, a detector can measure how much photons have passed through at what spot, resulting in an image of the breast in terms of density over the whole area can be produced. Because there is not a large difference between the densities of normal and malignant tissue, this techniques needs a lot of fine-tuning and is ill suited for breasts with high density.<sup>3</sup>

In photo-acoustic imaging a combination of both optics (as X-ray) and acoustics (as ultrasound) is used. Some parts have already been explained here but for the complete story read the article on PAM1 (page 75-76) and PAM2 (page 77).

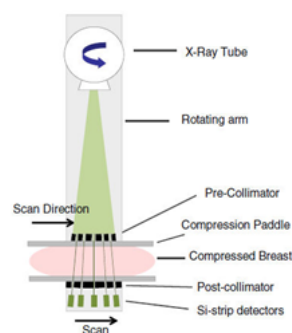

Figure 3: Retrieved from <sup>2</sup>

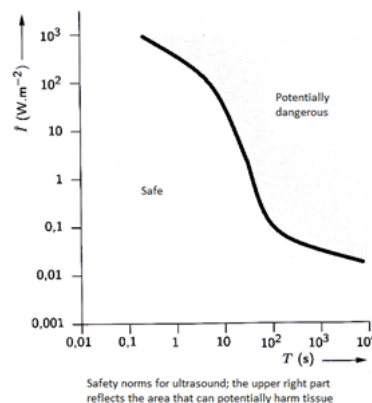

Figure 4: Retrieved from <sup>1</sup>

## References

<sup>1</sup> Van Oosterom, A., Oostendorp, T.F. (2008) Licht. In A van Oosterom and T.F. Oostendorp, *Medische Fysica* (3rd edition, 48-51), Elsevier gezondheidszorg, Maarssen

<sup>2</sup> Harris, T. "How X-rays Work" 26 March 2002. HowStuffWorks.com. <<http://science.howstuffworks.com/x-ray.htm>> 15 March 2014.

<sup>3</sup> Hewitt, J. Spectral system quantifies breast density (2012) Retrieved from <http://medicalphysicsweb.org/cws/article/research/50583>

# From fundamental science to the application

---

RUUD VAN LAAR

*How did fundamental sciences like sonar and optics lead to a technology such as the PAM? In this article, we analyse how fundamental sciences eventually lead to the development of a new science such as Photo-Acoustic imaging, which gave birth to a new technology; PAMmography. An historical overview of what happened to go from fundamental sciences such as optics and acoustics to Photo-Acoustic Imaging sciences to the development of a technological device such as the PAM.*

Photo-acoustic imaging is build up from three different parts. First there is optics (hence photo), then there is acoustics, and finally imaging.

## **Combination of optics and acoustics**

The field of optics has existed since the ancient Greeks who were already experimenting with lenses, but the field really took off when light was defined as an electro-magnetic wave. The acoustics field also originates from the same era, when Pythagoras wondered why some sounds sounded more harmonious than others did. The two fields were combined for the first time in 1880, when Alexander Graham Bell first noticed that sound was produced when a medium absorbed modulated sunlight, this principle is nowadays called the photo-acoustic effect.<sup>1</sup> There was little further research in the field of photo-acoustics until the invention of the laser, around 1960. Thanks to the invention of the laser, more research on this photo-acoustic (PA) effect could be conducted because the laser could deliver such high peak power while at the same time keeping spectral purity. At that time, the focus was on PA detection of gases with microphones and upon further experimentation with gases, researchers shifted their aim to characterizing the acoustic response of solids.

## **Photo-acoustics and Imaging**

Fast-forward from the 1960 to 1980 this technology was proposed for biomedical imaging, applying it to tissue. In that year H.K. Wickramasinghe, and C.R. Petts published an article named Photoacoustic Microscopy - A New Technique in Biology and Non-Destructive Testing. In their paper however, they showed their experiments on a slab of nickel and not yet in the field of biology.<sup>2</sup> At that time there was only

a small amount of researchers doing research in that area. In the mid 90's the field of photo-acoustic imaging got interested in biological applications. It took about another 10 years after that before the first compelling in vivo (in a living body) images were realized. From then on, both the technology and science have improved at great speed with the aid of better algorithms, sound detectors and the development of computing and processing speed.<sup>3</sup>

## **From PAI to PAMmography**

About the late 1990s, photo-acoustic imaging was already focused on imaging biological tissues so it was only a small step to focus on measuring breast cancer tissue. Soon after the use of Photo-Acoustic Imaging in biology, the idea to try and find cancerous tissue by means of photo-acoustics emerged and was explored in 1998 by the BMPI research group.<sup>4</sup> At that time their focus was on cancerous tissue in general which changed towards breast tissue because of its optical and acoustic characteristics. In this way, while researching the best way to make a 3D image of blood vessels in a chicken breast, the final steps towards researching and developing the TwentePAM were taken.

## **Analysis of the case**

In the foregoing historical review, we have seen the development phases of Photo-acoustic technology to what it is now. The next important question is whether there is a general way in which scientific research develops into a technical product.

At first, we have seen that science made a lot of steps to create the scientific area of 'photo-acoustic imaging'. Already, optics and acoustics had to be combined to generate the idea of sending light and



retrieving sound. Then the laser was invented to do this more efficiently. In order to research this, microphones of high quality were also required - ultra-sound detectors so to say. Finally, to process all the data for high quality images, the computing techniques in the field of electrical engineering were required.

With every part of these sciences is the involvement of technology. It was not just sciences that evolved out of the combination of scientific fields, the new technologies were essential requirements for new scientific fields to develop. Acoustic and optic

technologies had already existed and it was thanks to technologies such as the laser that this new area of research was possible. Now a photo-acoustic imaging device created in order to do more research on the possibilities of Photo acoustic imaging. This analysis shows that science and technology are shaping each other in order to come up with better products and better theories. Who knows what new scientific fields and which new technologies will follow from the current PAMmography technique and the science of photo-acoustic imaging? Further articles, below, will shed some light.

### Reference

- <sup>1</sup> Bell A.G. (1880) On the production and reproduction of sound by light. *Am. J. Sci.* 20, 305-324
- <sup>2</sup> Petts, C.R., Wickramasinghe, H.K. (1980) Photoacoustic Microscopy - A New Technique in Biology and Non-Destructive Testing. *1980 Ultrasonics Symposium*, 636-639. doi:10.1109/ULTSYM.1980.197476
- <sup>3</sup> Beard, P. (2011) Biomedical photoacoustic imaging. *Interface Focus* 6 vol. 1 no. 4, 602-631. doi:10.1098/rsfs.2011.0028
- <sup>4</sup> Hoelen C. G. A., de Mul F. F. M., Pongers R., and Dekker A. (1998) Three-dimensional photoacoustic imaging of blood vessels in tissue

# The four steps in PAM1

---

RUUD VAN LAAR

*The Twente PAM uses a photo-acoustic imaging technique to produce a three-dimensional overview of blood vessels in the breast. The workings of the device are best explained by isolating four different steps. It is interesting to see how these individual parts constitute the complete machine.*

## 1) Breast compression

The procedure for breast compression requires the patient to lie face down on a tabular surface. Their breast is put through a hole in the table and then slightly compressed between two plates. This slight compression is needed to create a good contact between the breast and the ultrasound detector plate. On the one side a glass plate that lets the laser light through and a wall with and on the other side a plate with an ultrasound detector.

## 2) Photon pulse

Instead of using X-rays, laser light is used with a typical wavelength of 1064 nm (this is just in the infra-red spectrum). At this wavelength, light gets absorbed by haemoglobin. As it turns out, cancerous tissues have an increased amount of blood vessels (and thus more red blood cells), so there is more laser light absorbed by these tissues than by healthy, surrounding tissue. As the photons hit this tissue and get absorbed, their energy is transferred to the molecules and the tissue temperature increases. This temperature increment causes the tissues with higher vascularization to expand creating a pressure wave in the breast, much like a sound wave. For accurate measurements one hundred 10ns photon-pulses are 'fired'. As shown in the picture on the right, the laser light is diffused before it hits the breast, so an area of typically 2,5 cm is illuminated.<sup>1</sup>

## 3) Acoustic 'hearing'

At this stage, the sound waves that are caused by the sudden vascular expansion are in the ultrasound (US) region, typically between 0,45 and 1,78 MHz.<sup>2</sup> By means of 590 unique elements the pressure waves are measured. These elements cover the area of a circle with 8 cm diameter, which is called the US detector.

The question that arises is why acoustic signals are used rather than the light signals and how are these acoustic signals then measured?

The answer to the first question is for practical reasons. The light scatters too much in the breast tissue to get a decent signal while pressure waves can travel through the breast tissue while keeping a high definition. Using the laser for illuminating the breast gives a good contrast in the picture while measuring the sound waves gives a high definition.

The answer to the second question - how exactly these pressure waves are converted to use-able data - is a bit more difficult.

For the purpose of measuring pressure waves, a special material is used, called polyvinylidene fluoride (PVDF). On a sheet of this material (110x(5x10<sup>-6</sup>) m thick, 90-mm diameter) 590 gold electrodes have been attached to form 590 individual elements of 2x2 millimeters. By means of spring-loading conductive pins the sheet can have contact with the electrodes while minimizing reverberations. On the other side of the sheet, the side that is in contact with the breast, an 18mm protective film of proprietary polymeric material is placed. This material has approximately the same impedance as breast tissue so the signal is not disturbed.<sup>2</sup>

The final step explains how this raw data, obtained from all these PVDF elements can be transformed into something the scientists can use to check for breast cancer.

## 4) Translation from raw data to image

The data (electronic pulses) that are obtained by the US-detector needs to be converted to an image. The signals are reconstructed with a 3D acoustic back-projection algorithm.

*Researchers' explanation*

“By knowing the geometry of the detector and assuming a constant speed of sound for the medium, the acquired signal are back-projected on spherical surfaces centered at the respective transducer element positions. The directivity of the transducer, in terms of acceptance angle and angular sensitivity, is taken into account to limit the spherical projections to the effective field of view of the detector element.”<sup>3</sup>

There is a lot of complex math involved in order to explain the exact ‘back projecting’ algorithm.<sup>3</sup> Here, a simplified explanation is given.

Having in mind what goes on when malign tissue is hit by a laser, the tissue increases in temperature which leads to an increment of size, creating a pressure wave with the malignant tissue as ‘sound source’. It is assumed that this pressure wave travels through the medium (breast) with homogeneous

speed, so the pressure wave will reach the detector element directly across it. Then the pressure wave will hit the elements surrounding the first element and so on. Per time unit, the pressure wave will hit the Ultrasound detector elements in concentric circles around the first element that was closest to the malignant tissue. This is because all these elements are at the same distance from the ‘sound source’.

At the same time, we have to consider that the US detector is positioned in 1 plane while the pressure wave is spherical, so the pressure wave hits the other detector elements at an angle which decreases the impact voltage. The algorithm looks at where on the Ultrasound detector the pulse started and how fast the pressure wave reached the other elements. This way it can calculate ‘back’ to where the source of the pressure wave is. The algorithm is of course a bit more complicated because there can be several pressure waves created at the same time, but this is the essence of it.

### Bringing it all together

When all these individual steps are brought together, the complete device can be made. The laser light is diverged with a lens to illuminate the breast in a specific area. The software knows where all elements are placed, and when and where the pressure waves hit the ultrasound detector. This way the machine can calculate where the pressure waves are coming from. By the ‘strength’ of the pressure waves, there is a higher or lower risk of malignant tissue because the tissue will create a ‘stronger’ pressure wave when there is more haemoglobin. In theory, tumours up to several millimetres can be measured.<sup>1</sup>

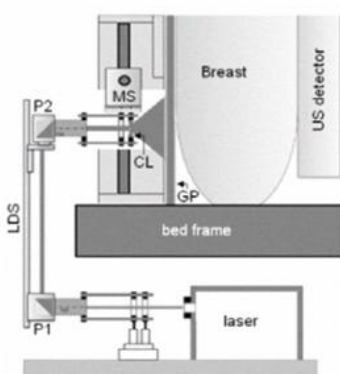

Figure 5: Retrieved from <sup>1</sup>

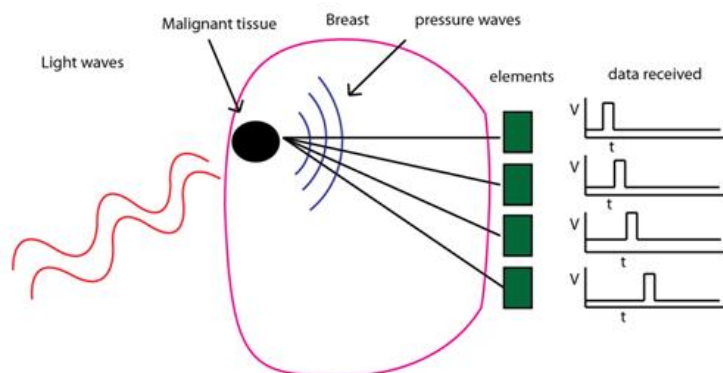

Figure 6: Copyright: Ruud van Laar, 2014

### References

<sup>1</sup> Piras, D., Xia, W., Heijblom, M., Van Hespén, J., Steenbergen, W., Van Leeuwen, T.G., Van den Engh, F., Klaase, J.M. (2011) Breast imaging with the Twente Photo acoustic Mammoscope

<sup>2</sup> Piras, D., Steenbergen, W., van Leeuwen, T. G., & Manohar, S. G. (2010). Photoacoustic Imaging of the Breast Using the Twente Photoacoustic Mammoscope: Present Status and Future Perspectives. *IEEE Journal of Selected Topics in Quantum Electronics*, 16(4), 730–739. doi:10.1109/JSTQE.2009.2034870

<sup>3</sup> Xu, M., and Wang, L.V., "Universal back-projection algorithm for photoacoustic computed tomography" *Phys Rev E Stat Nonlin Soft Matter Phys*, 71, 016706 (2005)

---

## To the future: PAM2 and beyond

---

RUUD VAN LAAR

The TwentePAM1 device has now been tested and developed and the researchers are already building a new version. This raises some questions: what was wrong with the first one? If the first version was not as good as the second, why did they build it?

Compared to the first version of the TwentePAM, there have been three major improvements and changes.

The first one is how the breast is held in place. In the PAM1 the patient was also laying down on a table but the breast was compressed in order to get a good contact between the skin and US-detector. In the newer version (PAM2) there is no need to do this. Now the breast is immersed in a liquid (water), so that screening is less painful.

A second change is the way in which the breast is lighted. In the first version the breast was lighted sideways. This now happens from both the front and sideways of the breast. In the bottom of the liquid barrel, there is a lens which disperses the light pulse on the entire breast.

The third change is the ultrasound detection. In the first version this would happen in one plane, perpendicular to the breast. In the new versions, the US-detectors are mounted in the configuration of a spherical surface.

There are also some changes that are gradually being made, such as improving the algorithms and other soft- and hardware components in order to

increase the efficiency, accuracy, and screening speed of the device. Now let us analyse these changes. The most fundamental components of the technology have been changed: the physical structure, the way in which the light is distributed on the breast and how the pressure waves are measured. We have seen here that the largest focus has been on the actual performance of this machine, and a bit on how it will be used. This is very much in line with what they ultimately want to create: a technology that is better than its competitors which is less invasive than its competitors.

### Conclusion

The answer to why this technology is being developed gradually and why we cannot build the ideal device from the start, is because that area of research is unprecedented. The researchers are exploring unexplored grounds and this requires the method of trial and error. Ideas may seem to be good in theory but sometimes there are practical issues that can only be found in practice. It is just not possible to consider everything that might go wrong. In cases of these high-tech devices it is more efficient to try and see what work and then figure out what laws apparently apply. Then with this new knowledge of mechanics of nature, developers can take another step in which they use the new-found knowledge to create a better device. This is an inevitable process in the development of technologies.

### Reference

Hilgerink, M. P., Hummel, M. J., Manohar, S., Vaartjes, S. R., & Ijzerman, M. J. (2011). Assessment of the added value of the Twente Photoacoustic Mammoscope in breast cancer diagnosis. *Medical Devices (Auckland, N.Z.)*, 4, 107-115. doi:10.2147/MDER.S20169  
"PAMMografie: Pijnloos Borstkankeronderzoek Voor Alle Vrouwen." *Flintwave*. N.p., n.d. Web. 18 Feb. 2014. <<https://www.flintwave.com/project/pammografie-pijnloos-borstkankeronderzoek-voor-alle-vrouwen/524161811075>>.



Figure 7: Retrieved from <<https://www.stemhwi2013.nl/stemmen/innovatieprijs/pa-imaging-pammografie/>> 18 Feb. 2014

## What can we expect from TwentePAM?

RYANNE DE BOER

*With 9 out of every 1000 screened woman diagnosed with breast cancer<sup>1</sup>, an accurate and precise breast screening device is an absolute necessity. It is also important that the number of false-positive and false-negative outcomes of the screening be reduced for medical, monetary, and social reasons. The false-positive and false-negative outcomes may be attributed to the limits of conventional screening techniques with poor resolution as the main troublemaker. X-ray mammography has a lower sensitivity in women with dense breasts (and breasts usually get less dense with aging).<sup>2</sup> Ultrasound imaging has difficulties in contrasting between soft tissue layers, where MRI has high sensitivity, but limited specificity.<sup>2</sup> The problematic aspects of X-ray mammography and MRI call for an alternative mechanism to breast cancer screening. In this article we take a first look at the viability of PAMmography to take this role.*

### **Photo-acoustics as superior to conventional techniques**

PAM combines the best of both techniques to address the poor resolution problem that occurs in conventional screening devices.<sup>2</sup> This hybrid technique brings together the optical contrast of photo-acoustic imaging and the low scattering experience of ultrasound, making it very promising for detecting abnormal tissue.<sup>3</sup>

The device as created by University of Twente has two prototypes so far: PAM1 and PAM2. PAM1 measured with a slight compression of the breast (but less than with X-ray mammography), a maximum imaging depth of 35 mm, and a (long) measurement time of 20 minutes per breast (see article The four steps in PAM1 for more information on PAM1). Also, more specific for the internal technology, corrections in image reconstruction (algorithm),

speed-of-sound distribution, and acoustic attenuation variations in the breast tissue need to be made. Furthermore, the characteristics of tumours must be defined in further studies, as well as lesion visibility scorings as a means to describe the performance of PAM in detecting cancer.<sup>3</sup>

With the PAM2, the definition of abnormalities was taken by a threshold of 50% of the maximum intensity value of the volume of interest. This meant that the size of the lesion was based on the maximum intensity of the breast. Also, in PAM2, the scan size of the lesion was limited, whereas only a limited amount of signals were used to reconstruct the lesion. By extending the measurement area, size and shape deviations might be avoided, without further increasing the measurement time per breast. The field-of-view is thus limiting and therefore has to be improved.<sup>4</sup>

With the potential of imaging the (amount of) vascularization that surrounds a malformation in breast tissue, potential tumours can be distinguished from cysts. This is often difficult to see on a X-ray image; ultrasound is a better device for such diagnostics.

Phantom (for PAM1 and PAM2) and clinical studies (for PAM1) show that the contrast shown by PAM was greater than the contrast shown by X-ray mammography, due to the optical and acoustic properties of the tumour.<sup>4</sup> This leads to the discrete conclusion that photo-acoustic imaging is a potential ideal method for breast imaging, mainly because of its hybrid character.<sup>5</sup> The absence of ionizing radiation, and external contrast agents also speaks in favour of the technique, but further clinical research with (un)healthy volunteers is necessary to transform this discreet conclusion into a sharp conclusion.<sup>4,5</sup>

### **Ideal target group**

The PAMmography technique can still accurately scan dense breasts, expanding the age restrictions that are relevant for mammography. It is expected that females from age 40 can be screened now that breast density is not such an issue any more. Photo-acoustic imaging seems thus to be a promising screening technique for breast cancer, but clinical trials still have to take place. This is a difficult route, since healthy and sick volunteers are needed instead of the previously used phantoms, and this requires support from several institutions, and a lot of money.

### **Photo-acoustics influencing screening attendance**

With TwentePAM as a more sensitive device than the X-ray mammography, which also leaves out the danger of X-rays, the percentage of females going to breast cancer screening might raise. Although the percentage of invited females who do not go

is not big (about 5-10%), the reasons why these females are not screened are uncertain. This might be because the individual has had breast cancer before, and is therefore already in touch with the clinic. It might also be that the danger of X-rays scare away the individual, or that the female does not believe in the aim of the screening.<sup>6</sup> This latter point addresses the controversy surrounding breast cancer screening, where on the one hand people are convinced that the screening reduces the mortality of breast cancer, while on the other hand people do not believe in the promises the screening programs provide.<sup>7</sup> It is said that the research results that show a decrease in mortality from breast cancer since the introduction of structured breast cancer screening, result from poor methodology.<sup>8</sup> It is suggested that it is not that clear if the screening still holds its primary goal: to reduce the breast cancer mortality rate of females. Other authors say that the claim of poor methodology is not well funded<sup>9</sup>, while also arguments arise on a mortality paradox: X-ray mammography screening may do more harm than benefit in women between 40-49 years old, and over-diagnosis is a major issue as well.<sup>10</sup>

This overview makes clear that the TwentePAM, as the project of prof. Steenbergen is named, wants to contribute in the battle against breast cancer, with a technique that challenges X-ray mammography and MRI on accuracy, sensitivity and price. It is a difficult route, as said before, and it takes patience and continuing improving the technique, to create a better scientific foundation for the results the technique leads too. This will make clinical implementation eventually possible, but first the results of clinical trials have to be gained and have to show that the TwentePAM has the potential to more efficient and accurate than X-ray mammography and MRI.

### **References**

- <sup>1</sup> *Nederlands Huisartsen Genootschap* (2014, February 25). Standaard Diagnostiek van Mammacarcinoom. <https://www.nhg.org/standaarden/volledig/nhg-standaard-diagnostiek-van-mammacarcinoom>
- <sup>2</sup> Xia, W., Piras, D., Singh, M. K. a., van Hespen, J. C. G., van Leeuwen, T. G., Steenbergen, W., & Manohar, S. (2013). Design and evaluation of a laboratory prototype system for 3D photoacoustic full breast tomography. *Biomedical Optics Express*, 4(11), 2555-69. doi:10.1364/BOE.4.002555
- <sup>3</sup> Jose, J., Manohar, S., Kolkman, R. G. M., Steenbergen, W., & van Leeuwen, T. G. (2009). Imaging of tumor vasculature using Twente photoacoustic systems. *Journal of Biophotonics*, 2(12), 701-17. doi:10.1002/jbio.200910025
- <sup>4</sup> Heijblom, M., Piras, D., Xia, W., van Hespen, J. C. G., van den Engh, F. M., Klaase, J. M., Manohar, S. (2012). Imaging breast

lesions using the Twente Photoacoustic Mammoscope: ongoing clinical experience, 8223, 82230C. doi:10.1117/12.90807

<sup>5</sup> Heijblom, M., Klaase, J. M., Van den Engh, F. M., Van Leeuwen, T. G., Steenbergen, W., & Manohar, S. (n.d.). Imaging breast tumor vascularization for detection and diagnosis of breast cancer.

<sup>6</sup> Interview with prof. dr. Steenbergen, (2013, December 23)

<sup>7</sup> Retsky, M., Demicheli, R., & Hrushesky, W. (2003). Breast cancer screening: controversies and future directions. *Current Opinion in Obstetrics & Gynecology*, 15(1), 1-8. doi:10.1097/01.gco.0000051562.77832.a9

<sup>8</sup> Götzsche, P. C., & Olsen, O. (2000). Public health Is screening for breast cancer with mammography justifiable?, *The Lancet* 355, 129-134.

<sup>9</sup> Kopans, D. B. (2003). The most recent breast cancer controversy about whether mammographic screening benefits women of any age: Nonsense and Non-science, *American Roentgen Ray Society*, vol 180, 21-26

<sup>10</sup> Baines, C. J. (2011). Rational and irrational issues in breast cancer screening. *Cancers*, 3(1), 252-66. doi:10.3390/cancers3010252

# What is holding the TwentePAM back?

---

RYANNE DE BOER, RUUD VAN LAAR

There are several obstacles faced by the research group led by prof. dr. Steenbergen, and they can be roughly divided in two groups: technological based and implementation based. Technological based obstacles refer to improving the technique to make it more efficient and more accurate. The Implementation based obstacles refer to the problems faced when the device needs testing to gain new data, to prove its accuracy and efficiency.

## TECHNOLOGICAL OBSTACLES

The first prototype of the device, the PAM1, was in some way similar to the X-ray mammography device: The breast had to be compressed, but with much less pressure, allowing laser light to go through the breast before detectors on the other side of the breast detected it. The sensitivity results of these tests were promising, but the images were not as good as was expected.

### Detector sensitivity

This ought to be solved within the PAM2, the second prototype. In this second prototype, the female lies face-down, allowing the breast to be immersed in a fluid filled container. This fluid filled container creates the possibility for homogeneous illumination as well as homogenous detection of the sound waves created by the light absorbing haemoglobin cells in tumour tissue. This will lead to better images, in the challenge to create images as good as MRI images are. With creating better images, the detectors also have to be improved. The detectors are not as good as desired, so improvement also has to be made in this area.

### Data processing

There is a lot of data that needs to be processed in a short amount of time. The first way in which to improve this process is to improve the algorithm that is used. When the breasts and the reaction of them so photon pulses are better defined, an algorithm that processes the information faster and gives more accurate results can be constructed. The second way in which to increase the speed of data processing is to increase the computing power. This will involve using more expensive equipment so that

with the aid of brute computing power calculations are finished faster.

### Ergonomics

While testing the PAM2, researchers noticed that not all women are able to lie on their stomach, which is required when the breast has to be surrounded with fluid without air. When these females sit up straight and their breast is lied in the container, difficulties with air between the breast and the ultrasound detectors, and less optimal transfer of the sound waves necessary for imaging. This raises the question on how to turn the technology into a tool that can be used in practice, since the sensitivity of the device is shown with scientific research results.

## IMPLEMENTATION OBSTACLES

For a new technology to be implemented in the clinical environment, and when there already is a device for the procedure, it is required to show that the technology has an equal or higher diagnostic accuracy than the conventional technique, and has equal or lower costs. Prof. dr. Steenbergen indicated that since the PAM is the product of an university's research group, the aim should be focused at optimizing the diagnostic accuracy of the PAM. For Steenbergen, the diagnostic accuracy is more important to focus on within the university, meanwhile trusting the industry in decreasing the costs and in making the device more attractive once the medical world has been convinced of the accuracy of the device.

### Shifting from University to company

Now the most fundamental research has been done, institutions will be more hesitant to finance further



conduction of the research. Now the money has to come from private investors such as persons or companies. The first step was made by the research group by setting up their own company. However, without money to invest it is difficult to grow so collaboration is of great importance. The group has put effort into contacting Siemens, who is currently active in building devices for X-ray mammography. This unfortunately did not work out.<sup>1</sup> In the article of "Reading the big boy's minds" we have investigated how these big players think, and there are various reasons that such a new - but promising - technology is not picked up by the large companies. First, there are already vested interests in the current product such as X-ray mammography machines. It is easier and cheaper to keep improving the type of machines they are already using, than starting a whole new product line. A second reason is that even if the company would want to develop this sort of technology, there are no infinite funds, and companies cannot develop every promising technology it stumbles upon.<sup>1</sup> Choices just have to be made.

#### **Walk through the 4 stages in clinical trials**

Scientific research for medical devices and medication occurs 4 stages. In stage 2, the device is tested on (un)healthy patients to see what its diagnostic accuracy is. This stage has yet to occur for PAM2. Testing has been done with phantom breasts, which allow the researchers to improve their algorithms and to see what the most desirable measuring characteristics are. Stage 3 has to compare PAM2 with the conventional devices, potentially showing that PAM2 is more accurate, cheaper, and thus better than the conventional devices. In stage 4, factors to optimize the equipment have to be determined, followed by the actual optimization of the equipment.<sup>3</sup>

#### **Showing potential**

Before the industry can get involved in further improving the technique, they have to be convinced about the diagnostic accuracy. This means that there have to be test results showing the actual accuracy. To provide this information, healthy and unhealthy volunteers are needed in order to image and compare the breasts. This phase 2 trial requires a lot of money, which can be raised via (crowd) fund-

ing. Earlier in the PAM project, institutions as the European Union, AgentschapNL, ProvincieOverijssel, and internal funding via the University of Twente provided enough to set up a research program and to get through the first 15 years. Nowadays it is very difficult to get funding for the project: recently the Dutch Cancer Foundation (KWF) denied a submission for funding. Another submission at the Dutch Technology Foundation (STW) had also failed, because of the spin-off prof. dr. Steenbergen had started. This spin-off is a small company mainly concerned with optimizing the data acquisition of the signals. This lack of (financial) support could be overcome by support from bigger, more commercial companies in the field, as Siemens or Philips. Those companies are mainly interested in optimizing existing techniques, not so much in developing new techniques, leaving prof. dr. Steenbergen and his project with very little behind.

**COMPETITION WITH OTHER NEW SCREENING DEVICES WHEN IMPLEMENTING NEW TECHNOLOGY**  
In the public medical sector there are much more regulations for technologies compared to the private sector. Because these technologies have to be used in cases of life and death, medical employees need to be sure that they can trust on what the apparatus gives as output. There are certain standards a new technology have to live up to before it can replace a current one. For a new technique to be able to be embraced by hospitals, there are several points which has to show that the new technology's is proven to be better than conventional technologies. Studies have to show the diagnostic accuracy of the PAM2, concluding that the PAM2 is more or equally accurate than X-ray mammography. This is the first proof that has to be gained. In addition, the expenses of PAM2 should be lower, or equal, to the expenses of X-ray mammography.<sup>1</sup> These two requirements may conflict with each other, in that one might be able to proof that a new technology has more diagnostic accuracy than the conventional method, but is more expensive. It will depend on what the hospitals can afford, and what technology they are searching for. Finally, hospital staff actually need to be persuaded to invest in this new technology. This requires more than publishing papers that

show the new technology is up to standard. The new company needs to actively promote the TwentePAM in order to get hospitals interested. The public opinion might be an important factor in lobbying for this new technology.

#### PUBLIC OPINION

When clinical experiments show that PAM2 has a higher diagnostic accuracy than X-ray mammography, the public opinion towards breast cancer screening might change. There is a minority of women who receive an invitation for screening, but who do not attend the screening. Why this is the case, is not always clear, but studies in the social sciences show that it might have to do with the harmful ionizing radiation, the discomfort of the procedure, or that the women is already in the screening program because of genetic heritage, early age breast cancer.<sup>1,3,4</sup> The information on this topic is limited and also data is difficult to obtain.<sup>4</sup> Since the PAM2

does not involve ionizing radiation or discomfort (if the woman is able to lie face down), issues concerning these two mentioned arguments might disappear. The relatively long measuring time is also something that has to be evaluated within further research, by asking women how they feel if the measurement takes longer, but provide the radiologist with better images and information about their breasts. The diagnostic accuracy is therefore very important, since it might change people's opinion about breast cancer screening. With the controversy around breast cancer in mind, not all people see breast cancer screening to reduce mortality as it is promoted by governments and breast cancer screening programs. PAM can play a role in this controversy, by making it more attractive for women to positively respond to the invitation for screening.

Overcoming these obstacles will be a difficult task and will require time, dedication, and a lot of money.

#### References

<sup>1</sup> Interview with prof. dr. Steenbergen, (2013, December 23)

<sup>2</sup> Retrieved from [http://www.novartis.nl/innovatie/klinisch\\_onderzoek.shtml](http://www.novartis.nl/innovatie/klinisch_onderzoek.shtml), Feb 26, 2014.

<sup>3</sup> Kaltsa, A., Holloway, A., & Cox, K. (2013). Factors that influence mammography screening behaviour: a qualitative study of Greek women's experiences. *European Journal of Oncology Nursing: The Official Journal of European Oncology Nursing Society*, 17(3), 292-301. doi:10.1016/j.ejon.2012.08.001

<sup>4</sup> Banks, E. et al. (2002) Comparison of various characteristics of women who do and do not attend for breast cancer screening. *Breast Cancer Research* 4(1)

# From scientific research and technological development to a better product for the clinic

---

RUUD VAN LAAR

*The TwentePAM is still a work in progress. Although at the moment money is low and research is going slow, researchers are still working on scientific and technological development of photo-acoustic imaging. An analysis of the current methods of the development of the TwentePAM is needed to provide a toolkit for improving efficiency.*

## **Development at Twente University**

The research group has received grants in the past to do fundamental research on how a photo-acoustic imaging device should interact with the human body and to learn the physics behind it.

There is a first version of the device in the local hospital, the Medisch Spectrum Twente (MST), where research on people who are already diagnosed with breast cancer is done. This is where research on humans takes place. The research on a fundamental level has been done for a large part and now the focus is shifted towards the creation of a product and optimizing it. The research group has set out the following goals (with additional price tags in cumulative order).

## **Application for medical-ethical testing committee - €2.000:**

In order to do medical research on humans, a testing committee has to approve of this and sending an application is pricey.

## **Tissue analysis - €12.000:**

The golden standard for diagnosing breast cancer is investigating tissue under a microscope. Special tissue analysis is necessary to create knowledge on what aspect of the tumour the PAMmography can find.

## **Additional research on 20-30 women - €32.000:**

In order to see what aspect of a tumour the PAMmography can image, results of scans need to be compared to results of scans with different techniques, such as MRI. Scanning the same group of women with different techniques gives valuable information on the performance of PAM.

## **Hire a medical researcher for a year - €87.000:**

A medical researcher is required to help with the investigation. He or she can help with applications for the medical-ethical comity, executing measurements and producing images.

## **Build an extra instrument - €350.000:**

An extra instrument can be build and placed in a centre for population research in the Eastern part of the Netherlands. This allows to research a large amount of women and how their (healthy) breast tissue responds to PAMmography. The technique may also already find some breast tumours that were not visible with mammography.

The research publications of 2012, 2013, and 2014 year have been mainly about improving technological components and the possibility to use the technique for 3D imaging.

The reason there is little about testing the device in the field is because there is no funding for that sort of research. This part of their study is focused on building this machine and institutions consider that the job of companies rather than academic scientists. This makes it very hard to apply for a research grant but the researchers of course were still in need of a device to do research on. So how did they solve this problem? They started their own company!

## **Development at the spin-off: PA-Imaging BV**

The company 'develops crucial components for photo-acoustic imaging such as digitizers and real-time 3D tomography software.' This means the company is creating technological products, which can be used for the research. The research that is done at Twente University produces knowledge that can be used for further development of the technological

products in the company. This development of the TwentePAM looks very similar to a R&D department. Besides the geographical difference, there also is a crucial difference in the mind-set of the collaborators. Within a firm the aim is to make money to keep the firm running and the focus will be on the best product. Only, the knowledge on how to do this is produced in academic circles. Here the focus is not on making money but on gaining knowledge. Within the university, the device is used as an 'experiment' in order to do research on the possibilities of this machine and to relate this to theory.

In the interview with prof. Steenbergen, we learned that the researchers have to keep a clear bifurcation between the research on photo-acoustic imaging for breast cancer screening and the development of the device to do this. Within the company there are more possibilities for developing this technology and it allows for easier collaboration with other companies or institutes. Academic business

### References

Interview with prof. dr. Steenbergen, (2013, December 23)

Retrieved from <http://www.flintwave.com/project/pammografie-pijnloos-borstkankeronderzoek-voor-alle-vrouwen#subgoals>

Retrieved from <http://www.utwente.nl/tnw/bmpi/publications/>

Retrieved from [http://www.ehow.com/how-does\\_4701566\\_research-development-work.html](http://www.ehow.com/how-does_4701566_research-development-work.html), Feb 18, 2014.

Retrieved from [http://en.wikipedia.org/wiki/Research\\_and\\_development](http://en.wikipedia.org/wiki/Research_and_development), Feb 18, 2014.

and the company can be managed from the same desk. It is up to the scientists to spend their time well and to do as their contract with the university states. It is important for them to have clear when they can focus on what interests.

### Conclusion

The current system in which the TwentePAM is developed is complicated because of the combination of University research and spin-off company. It would be simple if this all could happen within the same entity. The reason the research and development is currently split is mainly because of the lack of money. If the company was successful enough to facilitate both the research and development or if the research group could get grants to do both, it would not have to be this way. For now there is nothing else to do than to conduct the research with a tight budget.

# Reading the big boys' minds

---

PETER BINIPOM MPUAN

*In most parts of the world, academic research and industry are increasingly becoming connected. Educational reforms in some countries are well-known for moving towards career-focused academic programs that prepare students for easy absorption into the workplace. The University of Twente runs such type of an educational model and has, in recent times, been adjudged the most entrepreneurial university in The Netherlands - a result of the very strong focus on entrepreneurship and industry-focused research. This vision of the university is a key factor in the establishment of the Kennispark Twente which is famous for innovation and business start-ups. However, university research and education is not only relevant to this establishment but also to large industrial corporations such as Philips and Siemens and government agencies such as AgencyNL. The big boys are the institutions that have the money to take over the research or who can give grants. In terms of industrial relevant research and design, these institutions are the 'Big Boys' and the PAM research group has been in touch with some of these corporations on some terms.*

## **Getting familiar with the Big Boys**

We can distinguish between two types of 'big players'. On the one hand, we have the private sector, containing companies such as Philips and Siemens. On the other hand is the government and research institutions, represented by Agentschap NL and STW. It is incontrovertible that a good relationship between industry and education is important to boost innovation and continuity of scientific research. For this reason, the PAM has sought collaborative relationships with some corporations. Besides the large corporations, institutions such as the STW have oversight duties to identify and fund scientific research in The Netherlands.

This category of Big Boys are usually large production and distribution companies. They are multi-national and profit-driven companies. A typical Big Boy company has a R&D departments that is responsible for research into product discovery, design and development. Thus, they have well-resourced research facilities and personnel who are constantly engaged in research to improve on existing products or develop new ones. In the area of health, Philips is a leading innovator and supplier of health equipment. Traditional technologies such as MRI and X-ray mammography have already become roots of success for these companies. The big question therefore is how they view potentially revolutionary technology.

## **Viewing technical innovations from the eyes of the Big Boys**

Whilst emerging technologies owned by small enterprises usually face competition from already established ones belonging to large companies, it is yet unclear how existing corporations view such emerging technologies. It will be interesting to have empirical research that clarifies whether or not large corporations have a completely positive or negative view towards new and emerging technologies challenging their own existing product. However, the interest in economically viable and competitive technologies is a common factor that informs the view that corporations have towards prospective technologies. Also, whether or not the technology is a potential competitor also influences the view that corporations have for it. The PAM technology is a new type of technology gradually maturing into stability. The technology's potential to commercialize has arguably played a role in the establishment of a spin-off company in the university. An interview with Professor Steenberg revealed that these steps taken are preparatory to help promote research and development of the PAM, and the Big Boys are potential partners who can assist to drive the research into PAM forward.

"I would like to have them as collaborators. But I cannot really look into their

minds, how these companies think, it is different for each company. But it is my impression that they have their big lines in ultrasound, X-ray, and MRI, and now PET is also coming up. PET-MRI etc. Where they invest a lot of money in, but they aim not for revolutions, but more for incremental improvements. That is what the people of Siemens have said to me. Do not expect big disruptive things from us, we are going for the incremental things. . . . That extra features on devices are very nice. The technologies are great so I do not underestimate them or under appreciate them. If you look at these machines it is a really great technology, but they further develop it in steps, and add very nice features. And I can imagine, also from their point of view, if we show that with a completely different technology which is ten times as cheap, you can for a certain big disease area, create a solution for many problems. They have mixed feelings about it.”

- Steenbergen, 2013

The PAM research group has been very proactive in identifying institutions and companies with whom they can collaborate to promote the research and development of the PAM. The team submitted a proposal to Siemens for research sponsorship and received about €10 000. According to Steenbergen, this amount is a good gesture but far below the Siemens Company's ability.

In another account, the proposal by the PAM team for collaboration with Philips was turned down on the basis that it did not fit into any of the company's existing business models. Furthermore, the research team was struck with disappointment when their request to the STW for extension of funding was rejected on the basis that the PAM was already affili-

ated with an established company (The Spin-off). According to the STW, commercialised research is ineligible for funding as a matter of policy. The position of the big corporations and government institutions have been made clear from the researchers' experience with them. The STW did not approve of their proposal for funding because the PAM project did not meet the policy requirements of the STW. Philips, Siemens, and the like also have a keen interest in the economic factor. According to Steenbergen,

“They work with business models with which new technologies must fit before they can be considered for funding.”

According to Steenbergen, there are two critical factors that can attract the attention of the Big Boys.<sup>1</sup>

“First, you have to show that your diagnostic accuracy is as good as X-ray, or better . . . and the other one is that you have to show that it is equally expensive, or cheaper.”

Also, in breast cancer screening, diagnostic accuracy is a very important factor, and a technology with a more clear image is the ideal type that will attract immediate attention. The PAM is focused on this property and gradually seeking to enhance the quality of images of screened breasts. Professor Steenbergen noted that

“. . . In principle I think that showing that the accuracy is better is the most important thing, because I'm convinced that if you show that with a non-optimized instrument, which is still twice as slow, I think then the industry will jump in and within one year they can device an instrument which is still good but much faster. So I think that is what we should go for as a university, we should go for the diagnostic accuracy.”

## References

Interview with prof. dr. Steenbergen, (2013, December 23)

# A peep into innovation processes in science and technology

---

PETER BINIPOM MPUAN

*In simple lexical terms, innovation is understood as a concept that describes the process of making changes to something established by introducing something new. As an academic discipline, it is the study of the processes occurring in various other disciplines such as economics, business, engineering, science, and sociology. The multi-faceted nature of the discipline makes it difficult to give a universal definition of what innovation is.*

For a very long time now, many scholars have written on the subject of innovation, often assuming a linear approach to the process of innovation. In 1934, Schumpeter identified five types of innovation. According to him, the introduction of a new good, the opening of a new market, the acquisition of a new source of supply, the introduction of a new method of production, and the organization of an industry are five distinctive marks of innovation. In similar fashion, Rogers (1995: 163) identified five stages of innovation: knowledge, persuasion, decision, implementation, and confirmation.

Whilst earlier literature on innovation took a much more linear approach, latter studies have shifted from this perspective to one that recognizes that innovation processes are not necessarily linear processes, instead they are long winding, multi-linear, multi-stage and dynamic processes. According to Ramendra, et al. (2012), a study conducted by Van de Ven et al (1999) on health care innovations and other careers revealed how they are messy, dynamic, and of fluid quality and concluded that there is no one route to follow in an innovation process.

Some other scholars have defined innovation by relating it to products, services, mechanisms and technique that belong to business, organizations and institutions. Lynn and Gelb (1997) see innovation as the tendency of an individual consumer to adopt new products before large numbers of others do. This definition suggests that coming out with new products and staying ahead of others in taking it up is an essential determinant of innovation. Thus, innovation demands going beyond normal or existing trends to develop previously unknown products or mechanisms whilst staying ahead of

others in competition. Scholars such as Damanpour and Even (1984) have also defined innovation to include factors of environmental change and uncertainties that are managed by organizations through the application of new technology as well as the successful integration of technical or administrative changes into their organizational structure.

The TwentePAM is essentially healthcare technology whose mechanism for breast cancer screening largely differs and deviates from traditional breast cancer technologies. Innovation in healthcare is defined as those changes that help healthcare practitioners focus on the patient by helping healthcare professionals work smarter, faster, better and more cost effectively. It is evident in this definition that key indices such as smartness, speed, and cost efficiency among others are indispensable in bringing out new innovations. More so, innovations bring with them more efficiency, effectiveness and quality that enable better ways of functioning and goal attainment.

## **How innovations in science and technology are born**

The study of innovation in science and technology is an area that attracts attention in contemporary times. Several philosophical, sociological, economic and business models have emerged to explain and predict the processes by which scientific knowledge and technological developments emerge. The Social Construction of Technology (SCOT) and Actor-Network Theory (ANT) are two famous social theories that explain the processes by which scientific knowledge and technological developments are constituted and disseminated. Other models such as the Technology Acceptance Model (TAM),

Diffusion of Innovation theory (DOI) are known theoretical frameworks for understanding and explaining the innovation process in science and technology. Understanding these models serves as a compass for navigating the intricacies surrounding the innovation and development processes of the TwentePAM. The technology acceptance model (TAM) explains how people adopt and use technology and the key factors that influence them. The proponents of the model argue that by positively increasing the attitudes that people have towards technology, their usage or intention to use the technology increases. The question, however, is how people's attitudes towards a particular technology are positively increased. In an article by Ramendra et al. (2003),

---

**ANT** is a conceptual frame for exploring collective sociotechnical processes, whose spokespersons have paid particular attention to science and technologic activity. Stemming from a Science and Technologies Studies (STS) interest in the elevated status of scientific knowledge and counter to heroic accounts or innovation models, ANT suggests that the work of science is not fundamentally different from other social activities

---

According to Paisey (2004), **SCOT** views the development of technology as an interactive process or discourse among technologists or engineers and relevant (or interested) social groups.

---

two main factors have been mentioned, as identified in Davies (1989) as the most important in influencing the attitudes people have towards technology. They are perceived ease of use and perceived usefulness. This suggests that innovative technologies that have the potential to gain a positive attitude must be characteristically easy to use and useful in the eyes of people. Besides other reasons, a positive impression about a technology's ease of use and usefulness drives away doubts and offers an opportunity for adoption and use.

Innovation theorists, Tamayo-Torres et al. (2010) and Rogers (1995), put forward another framework for analysing innovations known as the Diffusion of Innovation theory (DOI). This model explains that innovation has two hinges: innovativeness and capacity to innovate. The theory employs a fundamental sociological approach in explaining how these two factors account for the level of intent to adopt and actual adoption of innovations. As it emerged from the numerous literature on innovation, the perceptions that individuals or organizations hold of a particular technology are important antecedents to their adoption or rejection of it. Basically, technologies that are new and potentially or actually relevant receive more acceptance than those that are not. In effect, scientists and engineers who are conscious of these expectations strive to meet them in order to get their pieces out of the shelves in good time.

---

### TwentePAM in the science and technology innovation perspective

The crux of understanding the dynamics of innovation in science and technology rests on understanding the position of the TwentePAM as a product of innovative science and technology in the University of Twente. There are two fundamental questions that require answers in this section: What processes of innovation are involved the TwentePAM? What are the characteristics of TwentePAM as an object of innovation?

**Process:** The PAM is a typical example of a disruptive technology in the healthcare industry. It is a radically new type of healthcare technology that employs mechanisms that are distinct from the traditional technologies. The sustainability of the healthcare system and continuous improvement in technology is very essential to guarantee quality

healthcare.

The goal of the BMPi research group is to have the PAM designed effectively, efficiently and easy to use in the diagnosis of breast cancer. The research group has no explicit or documented innovation strategy, however the group progressed through a systematic process of research, design



and engineering to come out with the PAM. As a purely scientific research group, it is unclear whether members are well-equipped with the competencies required to follow a laid-down innovation process.

**Object:** The PAM is a device designed to scan for tumours in the breast of women. Though not the first with such a function, the device is built on a novel mechanism that sets it apart from the others.

### **Management of healthcare technology innovations**

The management of innovations is a holistic practice that is present at each stage of the development cycle of the technology. In understanding how innovations are managed, scholars have identified some rudimentary innovation management techniques. Innovation Management Techniques (IMTs) refer to the range of tools, techniques and methodologies that support the process of innovation in firms and help them in a systematic way to meet new market challenges.<sup>2</sup>

Increasing the competitiveness of a technology essentially contributes to its success. Managing such technologies often involve the management of organizational knowledge, marketing strategies, project management and continuous upgrade. For a brand new technology, building people's trust and confidence is a first critical step that boosts the adoption and use of the technology.

The technology push theory of innovation explains that technology is mainly driven by the application of results obtained through research. Through R&D, new scientific knowledge is obtained and applied in the production of new technology or improvement of existing technology. The innovation pull theory explains the role which of market forces play in engendering technological innovations.

A fundamental responsibility of the healthcare system is to provide quality healthcare to people and efficient technology is indispensable in fulfilling this responsibility. In view of this, healthcare technologies are among the most regulated and controlled technologies to ensure quality performance. Hence, it is important for a technology to meet the expectations of the system in order to gain entry and use in the healthcare sector. Besides, the availability

of different types of advanced technology means that emerging technologies must possess superior qualities in order to compete with existing ones.

Managing healthcare innovations such as the PAM involves a constant check on the opportunities and threats that the technology faces.

### **Challenges in healthcare technology innovations**

Whilst scientists and engineers strive to apply their creative knowledge, skills and abilities to produce new knowledge and technologies, there are a myriad of constraints they constantly have to surmount in order to be successful. Ewan, et al. (2005) argued that social boundaries and cognitive or epistemological boundaries that exist between and within the professions stifle the dissemination of new developments. This idea suggests that the level at which scientists and engineers hold to their knowledge without the will to share it with other professionals greatly affects how fast such ideas gravitate towards success.

Environmental contexts within which scientists and engineers function can pose serious challenges to their innovativeness. Research on workplace dynamics has shown that low productivity is attributable to factors such as high hierarchical relationships, poorly distributed workloads, unclear goals and expectations, low remuneration and workplace conflicts. These factors do not only affect productivity but also constrain workers' creative thinking and motivation to pursue innovative ideas. Also, communication barriers and lack of free exchange of information has a direct debilitating effect on innovation in science and technology.

Obviously, continuous research and development in science and technology has an immense impact on the spate of which new products emerge in science and technology. Moore's Law explains that trends in computing technology reveals that there is an exponential growth in the complexity and a predictable period of 18 months for change or improvement in computer technology. This steady progress is closely tied to incessant and well-funded research and development. This indicates that funding is an essential factor that drives continuous

innovation and an absence of it has debilitating consequences on the pace of innovation.

Furthermore, some scholars mention poor management practices as factors that affect innovativeness. According to Van de Ven (1986), problems with managing attention, new ideas, part-whole relationships institutional leadership are identifiable factors that limit innovativeness. It is understood that innovation is largely a collective than an individual activity which requires a circulation of ideas in order to implement and institutionalize them. However, there is the tendency of individuals involved in the innovation to confine their ideas to themselves eventually losing sight of the innovation process over time. When scientists and engineers fail to align their innovations with the structures and processes set in organizations and industry, such innovations get constrained and eventually fail.

Another threat to innovations in science and technology is the immediate 'copying' of ideas and techniques by other scientists and engineers. According to Foxall (1988), 'new technology seldom remains the exclusive possession of its initiator for long'. Most innovations are either fundamentally different from existing technique or more advanced versions of existing technologies. Thus, rival organizations and industries are quick to update their

devices to match developing ones so as to maintain value and competitiveness. Leakages of upcoming techniques are very rampant in the science and technology community and are often sources of sabotage to innovative institutions, companies or organizations.

With innovation process swinging from one point to another, it is apparently challenging to provide a one-size-fit-all model that depicts the processes that innovations take place. However, a model presented in Van de Ven (1986), provides a trajectory that comes close to describing how new technologies such as the PAM undergo development over time (see figure 8). The TwentePAM is most likely in the early stages (threatening disruptive event and articulation). This is because the technology is very likely to transform the approach used in breast cancer screening technology but still seeking solutions to both technical and non-technical problems. The TwentePAM needs to graduate beyond these two to a higher pedestal (legitimation) by going through networks galvanization and political debate. Thus, the TwentePAM has to resolve all problems, stimulate and build networks, attract political attention and debate before gaining legitimacy to operate as an alternative device for breast cancer screening and diagnosis.

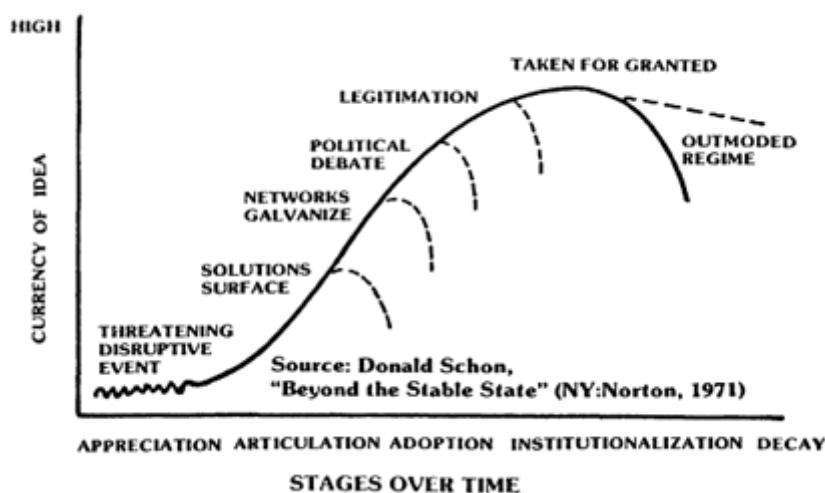

Figure 8: Managing life cycle of ideas in good currency.  
Retrieved from Van den Ven (1986)

### **Cracking the code of success - lobbying inside**

It is a daunting task to scholars and professionals to identify the singular factor that underlies successful innovations. In most success stories concerning innovations, several interconnected processes and best practices are identifiable as key in driving those innovations to success and for some, success is simply the low incidence of bad results. We make a distinction between the processes of innovation and the characteristics of the object of innovation as two broad categories that sum up the factors underlying successful innovations in science and technology.

It is widely accepted that good research is a precursor to successful innovations. Research and development has therefore become an integral part of the curricula of innovation driven institutions as well as the backbone of most industries and business in the science and technology industry. Good management systems are also essential in driving innovations to success. Since knowledge is created within an organizational environment, proper leadership, planning, communication, coordination and project management is necessary to mobilize and leverage resources, stimulate and enhance workforce potential. In relation to this, most organizations and institutions have well-crafted innovation strategies that guide their decisions and actions towards success. It is arguable that a well-made innovation plan is an important prerequisite that can predict the success of innovations as well as provide a working framework in realizing it.

Sociologists have offered the important insight that innovation diffusion may be driven by social contagion - another way of saying that actors' adoption behaviour is a function of their exposure to other actors' knowledge, attitude, or behaviour concerning the innovation. Researchers have offered different theoretical accounts of social contagion, each

describing a different causal mechanism of social influence.

A failure to distinguish between technologies that are sustaining and those that are disruptive. The challenge in innovation-minded organizations is to move from mere communication to coordination, and from this coordination to authentic collaboration.

Besides the process of innovation category, the characteristics of the object of innovation is a major determinant of its success. In this perspective, a so-called situational analysis of the innovation focusing on the product's characteristics, mode of commercialization and source of information. Per this analysis, certain characteristics are typical of successful innovative products and influential in the innovation's rate of adoption.

Technology that has low complexity is more preferable as compared to highly complex technology. Complexity in this respect refers to the user interface and not necessarily the mechanisms involved. The TwentePAM is based on complex scientific principles, it can be designed to provide a user-friendly for easy usage. Also, a successful healthcare device should express compatibility with existing the values in the healthcare system. The dominant values in the healthcare system include quality preventive and curative care, affordability and accessibility. It is not certain how the TwentePAM will affect these values, however, it has the potential to reduce the risks associated with traditional breast screening technologies and prevent unnecessary surgeries and delayed treatment based on false positives and false negatives respectively. Thus, the technology needs to be highly reliable and produce exact results under all conditions. Ultimately, a successful healthcare technology should be competitive enough to outdo the current systems being used.

### **References**

- Bamberger, M., Rugh, J., Mabry, L. (2006) *Real World Evaluation: Working Under Budget, Time, Data, and Political Constraints* (2nd ed.) Sage Publications Inc., 40-59
- Van den Bulte, C., Lilien, G.L. (2001) "Medical Innovation Revisited: Social Contagion versus Marketing Effort," *American Journal of Sociology*, vol 106, no 5, 1409-1435
- Cappellaro, G., Fattore, G., Torbica, A. (2009) "Funding health technologies in decentralised systems: A comparison between Italy and Spain," *Health Policy*, vol 92, no 2-3. 313-321
- European Commission, (2004) "Innovation Management and the Knowledge-Driven Economy", Brussels-Luxembourg: ECSC-EC-EAEC

- Ferlie, E., Fitzgerald, L., Wood, M., Hawkins, C. (2005) "The Nonspread of Innovations: The Mediating role of Professionals," *Academy of Management Journal*, vol 48. no 1. 117-134
- Foxall, G.R., (1998, online 2006) "Marketing New Technology; Markets, Hierarchies, and User-Initiated Innovation," *Managerial and Decision Economics*, vol. 9, no. 3, pp. 237-250 . John Wiley & Sons, Ltd.
- Paisey F., (2011), Social Construction of Technology. <http://www.slideshare.net/fpaisey/social-constructionism-of-technology>
- Ritzer G., (2005) *Encyclopaedia of Social Theory: Volume 1* Sage Publications Inc. London, UK., p38
- Rogers, E. (1995) *Diffusion of innovation* (4th ed.). The Free Press, New York, 204-251
- Sismundo, S. (2010). *An introduction to science and technology studies*. (2nd ed.). West Sussex: Wiley-Blackwell.
- Thakur, R., Hsu, S.H.Y., Fontenot, G. (2012) "Innovation in healthcare: Issues and future trends", *Journal of Business Research*, pp. 562-569, 2012.
- Van de Ven, A. (1986) "Central Problems in the Management of Innovation," *Management Science*, vol. 32, no. 5, pp. 590-607

# Conducting research with a tight budget

PETER BINIPOM MPUAN

*Technology innovations are often closely tied to the practical reality of funding. The emergence of new technology is usually preceded by many years of extensive and expensive research. Whether educational or industrial research, hard-earned money is spent on requisite human and non-human resources to drive the innovative process.*

The Biomedical Photonic Imaging (BMPI) research group is a part of the MIRA institute of technology of the University of Twente. Their main research approach is investigating light-tissue interaction with the aim to develop optical and hybrid optical-acoustical technologies for medical diagnosis in the fields of oncology and wound healing. The research team is a dynamic group primarily composed of university Professors, Postdocs, PhD and Master students as well as some administrative staff (figure 9). The head of the research group, Professor Steenbergen, explained that the daily laboratory-related tasks of researching, making sets, measurements and calculations are mainly the responsibility of PhD students, Post-docs and technicians. In addition, Professors, Assistant Professors and also Post-docs have supervisory roles where they apply their practical knowledge in addressing the problems that arise in the course of completing detailed projects.

The research group has the unique task of combining scientific research with technological design. On the one hand, the research group is engaged in purely scientific research that involves conducting experiments on new techniques and models. On the other hand, they are engaged in designing and engineering the whole PAM instrument. This puts extra cost to the already limited funds available for the project, and in order to sustain the budget, it is necessary for them to obtain extra funds to keep the project running.

As a research group belonging to the MIRA institute of technology, the group has access to the University of Twente's resources such as research laboratories and offices. These resources are sufficient to carry out normal experiments on a daily basis; however, research on the TwentePAM requires extra effort and resources which makes funding a very important factor. Thus, besides their basic funding from within the University of Twente, the BMPI is engaged in generating revenue from external sources in order to keep the research on PAM running. In this section, we delve into the financial status of the TwentePAM research team by examining their sources of finance as well as the financial challenges they face and how that affects their research.

## **How TwentePAM is been funded so far**

Funding is an essential factor in scientific research and the same applies to PAM research. The team of researchers relies on funds from a combination of different sources to carry out their research activities.

**EU and Dutch government:** The PAM research had its debut with funds from the European Union about 15 years ago. In addition, they have received some monetary support from other institutions such as the Dutch Ministry of Economic Affairs, AgentschapNL, the Province of Overijssel, High

Tech Health Farm over the course of time.

**UT spinoff company:** The University of Twente is famous for its entrepreneurial outlook, and apart from being the main funding institution for the PAM, it also holds some shares in a spin-off company founded by the PAM research group. The company plays an important role in separating scientific research from design. Researchers in the PAM contribute some time to working in the company; however, they are careful not to substitute it for their main research and education tasks in the university.

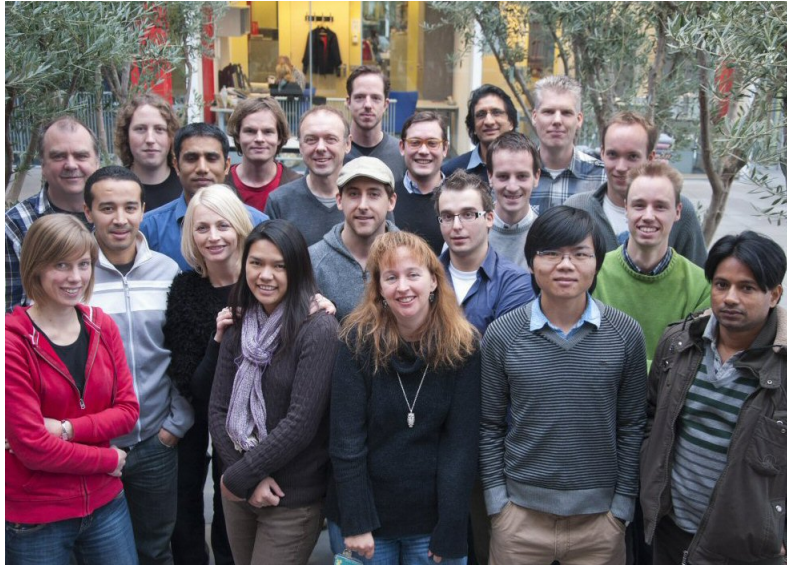

Figure 9: The BMPI research group

**Participation in competitions:** The PAM research group continues to take initiatives to enable them secure more funds for their research. One of such initiatives is engaging in prize-winning competitions such as the Academic Year Price. The group entered the list of finalists in 2013.

**Proposals for funding:** The team continues to seek funds to support research on PAM through proposals to funding agencies and organizations. They write proposals for grants from STW.

**Productive partnerships:** They are also seeking to establish productive partnerships with some key industry players such as Philips. According to Steenbergen, the MST and the High Tech Health Farm are key partners. The MST partnered with the researchers to undertake a pilot using the PAM1 model.

**The impacts of limited budget on research**  
 Conducting scientific research has never been easy, especially when the research team combines their research responsibilities with other tasks such as mobilising resources and coordinating out-of-the lab activities. A big fear is that a research team will ever encounter is when there is no stable and reliable source of funding to run things. The PAM research

team has not been spared this problem, and instead been constricted by financial shortages. Right from the early days of their research, the team undertook some austerity measures such as making do with borrowed parts such as ultra-sound detectors and benefiting from the benevolence of others to maintain these parts. They went through thick and thin to turn their ideas of the first prototype into fruition. Even in those times, it was much easier because the team received funding from the University of Twente and STW.

*Stall pace of research:* In most practical situations, having inadequate funds is a big obstacle to overcome goals and objectives in stipulated time. In the same way, most innovative research groups such as the PAM team have to grapple with limited finances, which has had a rather debilitating effect on their research work. Budgetary constraints have slowed down the pace of the research work conducted out by the group. Rationing resources: Rationing resources refers to the allotment of resources for carrying out specific tasks. For researchers who run on a tight budget, expending money and other resources extravagantly is very unlikely, instead, these researchers exercise thrift in using the funds they have. The PAM researcher group is faced with this problem and is taking prudent measures to expend its limited resources in an effective way.

*Opportunity costs:* Rationing resources comes with its own advantages and disadvantages. On the one hand, it helps to maximise the use of resources, but on the other hand, an opportunity cost arises. By prioritising and rationing resources, researchers decide to execute those aspects of the project they regard most relevant. Consequently, the value of the forgone alternatives cannot be realised. This has repercussions such as limited innovation and lack of flexibility.

*Multitasking:* For a research group faced with limited resources, it becomes essential to combine researching with fund raising. Thus, researchers are compelled to shed some concentration on the research work to pay attention to revenue generation. This is one key characteristic of the PAM group. Although, their ability efficiency in multitasking and entrepreneurial efforts are laudable, it would be much more relieving if they had no need for it. Every researcher will agree that having enough money available to fund projects is a necessity that boosts efficient and effective performance. Specifically, money is the lifeblood of the project and sustains it.

*Allows more freedom and concentration:* A well-funded research project devoid of financial constraints is blessed with financial freedom which is in turn accompanied by the opportunity to concentrate on the main goal of a project - researching. For PAM research group, having more money is the key to continuing their research, which is temporarily on hold.

*Limits unhealthy competition:* Apart from increasing the freedom and concentration on completing research goals, availability of money also limits the amount of unhealthy competition that the researchers experience.

*Further Research Possibilities:* A research project unbound by financial constraints is much more likely to lead to additional research possibilities than one constricted by financial problems. This is because of a higher freedom of experimentation.

### **Moving forward: how TwentePAM research can survive**

The PAM research group is determined to make success despite the financial challenges. The team can move forward with research on PAM by considering and adopting a number of measures in addition to those they have already resorted to.

*Prioritize:* First, it is important that financially constrained research project set priorities or a scale of preference. This includes putting the most important things first and executing them downwards. Though a desperate measure, it is a crucial step to ensuring that the research process is not stifled due to limited resources.

*Simplify Goals:* Second, research teams can simplify research goals by separating theoretical research from design. Arguably, most research projects begin with broad and ambitious goals. This is a positive step as it provides room for promising results. However, it is essential that projects running on limited funds trim down their research goals. For the PAM, a dissection between theoretical research and technological could be considered. This way, demand for money for the project will be reduced.

*Avoid re-inventing the wheel:* Another important measure to reducing the effects of limited resources in a research project is to avoid reinventing the wheel. This means sourcing already existing tools or parts that are needed for the project instead of building them from scratch. According to Steenbergen, a case in point in the PAM research is the use of a US-made detector borrowed from an American company, which is a cheaper option as compared to building their own detectors.

*Strengthen Corporate partnership:* Strengthening cooperation with industrial corporations is another viable option available to financially embattled research groups. According to Steenbergen, health insurance companies such as Achmea or Menzis, could be very helpful if a good partnership is established with them. The PAM is a clinical technology and can draw the interest of stakeholders

and the medical scientific community

*Fund Raising:* According to Steenbergen the PAM research is at a crucial stage because the funding insecurity is at its peak. Therefore, a crowd funding action has been started but has not really yielded any successful results yet in terms of money.

*Policy Amendments:* In the interview with Steenbergen, he mentioned that

“STW has so called valorization grants, but these are not open to groups who already have a company”

as a matter of policy. He expressed his dissatisfaction with the policy because of its negative implications for those research groups like the PAM who have the entrepreneurial urge and set up spin-

off companies. He mentioned that the policy is crippling to action research and has the capacity to kill innovation. His proposal for additional funding from the STW was rejected on the basis of this policy which is rather unfortunate. For this reason, changes in such policies are absolutely necessary in order to sustain research projects and encourage entrepreneurship.

*Proposed Funding Program:*

“In the end it’s all about funding”  
- Steenbergen (2013)

According to the seasoned scientist, there should be a grant or funding program typically established to fund research projects and the development of emerging technologies like the PAM.

### References

Interview with prof. dr. Steenbergen, (2013, December 23)  
Retrieved from <http://www.utwente.nl/tnw/bmpi/>



# Surviving the Medical Valley of Death

---

*The X-ray mammography is the technique used in the screening for breast cancer under women of 50 years and older. Because the pammography will develop in the same field as the mammography, there might be some valuable information in the development of the mammography. An analysis of the history of mammography, based on Lerner, B.H. (2001), will provide us with useful information. This analysis will show what can be learned from the development of the great competitor of the Pammography.*

---

## ***The X-ray mammography***

---

RUUD VAN LAAR

Only a short period after the discovery of X-ray, in 1895, physicians began to use the technology to view the human body. In 1916 the idea to use the technique for breast cancer screening was constructed and in between 1930 and 1950 physicists with an interest in radiology were promoting mammography as an addition to breast cancer screening but the quality of the technique was not high enough and so adoption was out of the order. In the late 50s, Robert L. Eagon altered the technique, which allowed for two things: first, it improved the quality of the technique so that it was way more sensitive. Second, other researchers could easily reproduce his research, and this confirmed for others that it was a working technique. In 1960 he showed that he could detect breast cancers that were not seen in the original examination. The American Cancer Society had already concluded that breast cancer could best be prevented if detected at an early stage. In 1961, mammography researchers got together to share their results, problems and solutions.

Eventually, they broke the surgeons scepticism by keeping to build prove that mammography could detect tumours the surgeons could not detect. This was partly dedicated to the 'seeing is believing' state of mind. Until the 60s, the mammography was only used when normal examination was inconclusive. Then, dependent on the mammography a surgeon would do a biopsy or not. In 1964, a clinical trial was proposed in order to use the technology as a screening tool. In the clinical trial, that lasted 4 years and examined 64.000 women, researchers concluded that there was a 30% smaller death rate

in the group that received screening with mammography compared with the control group. The mammography was only useful in woman aged 50+ because younger woman had denser breasts that were too hard to examine by mammography.

This led to another research in 1972, where mammography would be tested as a screening device. Due to the large 'war against cancer' there was a lot of money to spend and a trial with 29 clinics that involved over 250.000 woman over 5 years was started. This was called the Breast Cancer Detection Demonstration Project. (BCDDP). When in 1974 First Lady Betty Ford and Margaretta (Happy) Rockefeller announced they had been diagnosed with the disease, women got more interested in the screening and the mammography could provide a means to detect their disease. By this time the media were positive about the developments of the BCDDP and praised how the screening saved lives.

Bailar was very sceptical about the screening. He published an article that claimed that we can not at all be so sure about the effects of screening. Also, the radiation of the X-ray can even cause breast cancer and why was there not any more research on that? This caused an investigation that led to drop mammography research by the BCDDP on women below 50. In the years after, mammography screening was constantly available and the discussion people of what age should be able to participate has not been resolved yet.

### **Analysis of mammography**

The analysis of the mammography shows an inter-

esting case. Important developments took place in the fields of science, technology, finance, society and the embedding of the technology.

#### *Scientific*

The scientific community had been skeptical about the development of this new device. Only after a breakthrough in the technology that was verified by other researchers did it find some ground. This means the science had to be developed until a certain standard before it was considered to be a serious field that could help in the medical field.

#### *Technological*

During the development of Mammography there was no technology that could screen for breast cancer so there was no competition of another technology. X-rays were already used with success for whole body screening, which gave the impression that X-rays were useful for medical practice. From the use for body-screening, X-ray developed to be used for cancer as well. This shows that mammography was not suddenly there all but slowly worked its way in hospitals for medical use. It was necessary for the technology to gain trust of the people and a trusted technology such as X-ray had the best position to be used for breast cancer screening.

#### *Financial*

The start of the development of Mammography was very slow and there was little financial support. Only after WWII, when the economy stabilized, the technology received a boost thanks to the war on cancer. There was a lot of interest of the government to be able to control this disease, which was one of the mayor causes of death at that time. This was an ideal time to apply for grants for research and institutions were very likely to fund technologies for cancer screening. This shows us a technological development might depend on the social context in which it is located.

#### *Society*

When the two prominent women announced they too had breast cancer, it led to an increase of women who wanted to take control over their health and this technology provided the best way to do this and gain information on the current state of her breasts. This was combined with newspapers reporting that this technology could discover cancers the surgeons could not.

When, despite the controversy on the usefulness of screening, the trial had ended in 1970, women over the country had gotten used to the technology and during this trial the technology had been embedded in society and so would keep being used.

#### *Development and embedding*

Although several initial researchers believed in the technology, it took over 30 years of developing and promoting before mammography was used in trials and the entire medical world got acquaintance with the technology. Almost all parties were skeptical about the new technology at first and it took time and effort to convince them. It also appeared that the technology just was not suited to diagnose women with dense breasts and the technology could not help those persons.

#### *what does this mean for the BMPI research group?*

The mammography was not just there at the right moment at the right time. It was already there for over 30 years before the right moment came along. The PAM group has to realize that it can take a long time before society recognizes the need for this technology. However, to make that can happen, society needs to realize the technology is there. Studies should be done on whether we can expect society to realize the need for pammography and what can be done in order to help that process speed up - within ethical boundaries. As long as that desire for such a technology is not there, the research group will have to work slowly and with a tight budget towards proving and improving the efficiency of the technology.

## **References**

Lerner, B.H. (2001) "To see today with the eyes of tomorrow - A history of screening mammography"

---

## Breast cancer controversy

---

RYANNE DE BOER

*Before pushing this technique into the world, we must ask ourselves: Do we want this new technique out in the world? Would it be responsible to let this new technique go out there? What consequences would it bring? With scientific research showing that breast cancer screening actually reduces mortality from breast cancer, it does not mean that there is no controversy surrounding the screening. Screening policies provides bi-annual breast screening for women over 50 years old in the Netherlands. This way of screening prevents a number of women from dying because of the disease, and has thus been reviewed as successful and a valuable player within the diagnosis of breast cancer. On the other hand, the current screening technique is painful and invasive, causing damage to the body. So much damage perhaps, that in the end the screening causes more damage than it prevents, by the method itself or by the following procedure. Different scientists reach to different conclusions, so this should get interesting. Let's take a look back at what actually happened 13-14 years ago.*

With X-ray mammography promoted and reviewed as valuable and almost a necessary obstacle to overtake every 2 years, the opponents opt for a more critical attitude towards the screening, arguing that the screening is not as reducing as said. Two Danish researchers Peter Gøtzsche and Ole Olsen ask in their article “*Is screening for breast cancer with mammography justifiable?*” (2000) several questions about this reduction: With screening being recommended to reduce breast cancer mortality, does the screening actually do what it is aimed to do? In a Cochrane Collaboration review, the researchers performed meta-analysis on randomized trials they gathered from the Cochrane Library on mammography, concluding that the majority of the analysed studies were methodologically inadequate in setting baselines for the control group and the study group, together with inconsistencies in number of randomised women. Only two of the eight reviewed mammography screening trials were found methodological unbiased, and did not show any effect of screening on mortality from breast cancer. Also, if all the reviewed trials were unbiased, the overall conclusion would have shown that screening 1000 women biennially for 12 years, one breast cancer death would be avoided whilst there will be an increase of death by six. This lead for the researchers to the conclusion that the effect of screening programs is small, and that there is a very delicate balance between beneficial and harmful

effects of the screening. For Gøtzsche and Olsen, screening for breast cancer with mammography is therefore unjustified.<sup>1</sup>

The conclusion is remarkable, since it is completely opposed to what the governments and screening programs have said for years. These results were picked up by the New York Times, which created a front page article, and distributed it among people.<sup>2,3</sup>

Daniel Kopans, a radiologist specialized in mammography and other forms of breast imaging and leading figure in the breast cancer screening controversy, reviewed Gøtzsche and Olsen's article, explaining how this article has started a controversy on breast cancer screening.<sup>2</sup> Kopans concludes that Gøtzsche and Olsen's article was unscientific and finds some strange things going on around the publication of the article, which also confirms Kopans' standpoint in favour of the benefits of mammography.<sup>2</sup> The media did not wait for any scientific comment on Gøtzsche and Olsen's article to appear but published it right away for the maximum amount of sensation.<sup>2,4</sup> The statements of Gøtzsche and Olsen were highly criticized following the publication (in both The Lancet and New York Times), mainly by researchers directly involved in breast cancer research.<sup>4</sup> Without reaching any conclusions, the discussion went on and fragmented into disputes on single issues. The Cochrane Collaboration did not endorse the paper,

complicating the controversy since Götzsche and Olsen used the Cochrane evidence-based results concept.<sup>4</sup> Also, since the controversy has political and economic meaning, it was necessary to look more into the trials, trying to find a general conclusion on whether breast cancer screening with mammography reduces breast cancer mortality. It was uncertain if the results of Götzsche and Olsen affected the attendance of breast cancer screening, so it was necessary for a methodologically correct review to clear the air.<sup>4</sup>

Data suggests that breast cancer therapies are most effective when cancer is diagnosed early. The paradox here is that screening for women in age 40-49 seems harmful, 6-8 years after screening. A possible reason for this is that although it is a good thing that cancer is found at an earlier stage, the surgical intervention following the findings accelerates metastatic growth. This offsets the benefit of early detection.<sup>4</sup> Premenopausal women tend to have a higher number of false-negatives, which also speaks in favour of screening women over 50 years old, or postmenopausal. Menopause thus seems to play an important role, for one of the characteristics of premenopausal women is that they have higher levels of angiogenesis active factor.<sup>5</sup> For a tumour to grow, a web of microvessels is necessary to allow the cells to grow. Via the blood vessels, the cells are provided with nutrients and oxygen, allowing the tumour to grow larger, with the possibility of metastasis. Therefore, elevated levels of angiogenesis active factor in premenopausal women might trigger tumour growth.<sup>6</sup>

It thus looks like that there are several reasons

for breast cancer screening programs to only invite women over 50 years old in the Netherlands. Besides breast cancer density, as mentioned in article Breast cancer screening with X-ray, also the menopause plays a role. The harms of X-ray mammography in women under 50 years old might thus be higher than the benefits, resulting in screening programs excluding women under 50 years old.

It is genuinely expected for younger women to have denser breasts, and that the breast density decreases with increasing age. This is shown by a 2010 trial, where 7007 mammography screenings were evaluated on this aspect (median age 57 years). The result of the trial was an inverse relationship between patient age and breast density. The study concludes that increased breast density renders X-ray mammography a less sensitive tool for early detection of breast cancer, since a large portion of the screened postmenopausal women had a pattern of dense breasts.<sup>7</sup> Since dense breasts limit the sensitivity of the examination<sup>7</sup>, it may be questioned what the benefit of X-ray mammography for women with dense breasts is. The TwentePAM seems to have the potential to be the solution for this dense-breasted group of women, for it appears to be better able to create an accurate image of dense breasts than X-ray. In a better differentiation between healthy breast tissue and unhealthy breast tissue, a number of late diagnosis of breast cancer might be prevented. In prevention of late diagnosis, by more accurate screening, TwentePAM might have a contribution in the controversy that goes on about X-ray mammography screening.

## References

- <sup>1</sup> Götzsche, P. C., & Olsen, O. (2000). Is screening for breast cancer with mammography justifiable?, *Public Health*, 355, 129-134.
- <sup>2</sup> Kopans, D. B. (2003). The most recent breast cancer controversy about whether mammographic screening benefits women of any age: Nonsense and Non-science, *American Roentgen Ray Society*, vol 180, 21-26
- <sup>3</sup> Kolata, Gina (February 26, 1993). "Studies Say Mammograms Fail to Help Many Women". The New York Times. Retrieved April 12, 2014.
- <sup>4</sup> Retsky, M., Demicheli, R., & Hrushesky, W. (2003). Breast cancer screening: controversies and future directions. *Current Opinion in Obstetrics & Gynecology*, 15(1), 1-8. doi:10.1097/01.gco.0000051562.77832.a9
- <sup>5</sup> Heer, Kumar, Speirs et al. (1998) Vascular endothelial growth factor in premenopausal women—indicator of the best time for breast cancer surgery? *Br J Cancer*, 78:1203-1207
- <sup>6</sup> Kumar., & Clark, (2007). Malignant disease. In Kumar (Ed.), *Clinical Medicine* 6th ed., p. 485. Elsevier Saunders.
- <sup>7</sup> Checka, C. M., Chun, J. E., Schnabel, F. R., Lee, J., & Toth, H. (2012). The relationship of mammographic density and age: implications for breast cancer screening. *AJR. American Journal of Roentgenology*, 198(3), W292-5. doi:10.2214/AJR.10.6049

## Responsible Innovation

RYANNE DE BOER

Responsible Innovation is a research field that pays particular attention to the ethical and social consequences of technological developments. These aspects may not be within the immediate sight of the researchers, since money and effectiveness are their main focus points, as is shown in health technology assessments. With emerging technologies such as PAM, evaluations in which more social aspects are highlighted might be contributing to the health technology assessments performed. Responsible innovation lies emphasis on changing roles, responsibilities, and meanings of breast cancer screening and breast cancer, which may change because of the emerging technology.<sup>1,2</sup> These social aspects can be evaluated by consulting different stakeholders for their point of view.

Consulting different stakeholders is also the strategy of analytic hierarchy processes, which are a form of health technology assessment. For stakeholders have different perspectives on the new technology, evaluations with these experts will lead to a broad reflection of the technology, in which the desirability of the innovative technology is discussed.<sup>1,3</sup>

With addressing these broader impacts of the technology, larger public support may be created, since it regards future users (patients as well as medical professionals). This may help in getting a better result from crowd funding. It may also lead to more financial support from for example STW, Philips/Siemens, NWO, or the KWF (Dutch Cancer Foundation). The sociocultural aspects of the PAM should be evaluated in order to create new funding applications to attract a larger public support to help obtain funding. This is also obligatory when one wants to send in a proposal to NWO-*Maatschappelijk Verantwoord Innoveren*.

In addressing the sociocultural impacts of PAM, Boenink et al. (2011) have proposed a method to assess the broader impacts of an emerging technology. This approach can be compared with the health technology assessment (HTA). In their article, Boenink et al. (2011) argue that HTA is limited in

its scope since it focuses on clinical efficacy and potential risks or side effects (the so called hard impacts). Social and cultural impacts as the meaning of the technology for its users, and changing roles and responsibilities within its medical context are neglected: the impact of the technology on the organization of the medical field the technology will be in (the so called soft impacts). Adding the social and cultural impacts to the analysis of emerging technologies will give the developers the opportunity to tune their technology to the needs and values of targeted users, which will hopefully result in the acceptance of more robust and useful technologies.<sup>2</sup> An analytic hierarchy process (AHP), as performed by Hilgerink et al. (2011) for the PAM2, is a multi criteria decision analysis, which quantifies stakeholders' opinion on the technology. This method might address more aspects of a technology than a HTA does, but that depends on the interest of the researcher. In this particular research, costs, effectiveness (in terms of sensitivity and specificity), patient comfort, and safety/risks were addressed. After the framework of variables was defined for the expert panel, with explaining the goal, criteria, and alternative techniques for the technology (PAM in this case), different experts expressed their opinions on the criteria.<sup>3</sup> Three different scenarios of combinations of technologies were constructed: negative, average, and positive, for PAM2. The results show that, from most of the offered scenarios, PAM2 is preferred over the alternative MRI, mammography and US, and mammography with PAM2. The expert panel consisted of professionals who were familiar with the technology, for it was better accessible.<sup>4</sup> Since the majority of the consulted experts was familiar with the technology and with prof. Steenbergen's project, the AHP was not independent. Also, the focus of the AHP was on the clinical effectiveness and costs of the technology, so no social or cultural aspects were addressed. This does not mean that the performed AHP was useless: it is in fact a very useful tool to quantify the criteria for the technology from experts, especially when it is performed with

an independent expert panel.

Although it is difficult to evaluate social and cultural impacts, it is not impossible, and certainly not less relevant.<sup>2</sup> To evaluate the broader impacts of a technology, soft (sociocultural) impacts should be taken into the evaluation, therefore a broader approach is needed in addition to a AHP or HTA. Several steps need to be taken in order to assess the broader impacts of technology. First, a conceptual analysis of the underlying ideas of the technological development must be done, as it will show how the technology will redraw boundaries. Second, designing imaginative scenarios will help illustrating future implications of the technology, on social, cultural, economical, and technological level. The third and final step is reviewing the possibilities for consideration of the potential social and cultural impacts.<sup>2</sup> Without technology fully emerged, speculation remains in creating the scenarios. There are a lot of uncertainties, making it difficult to determine the desirability and/or outcome of the technology. Even though this is difficult, it is important to try to foresee (some of) the effects of a technology with using scenarios; at an earlier stage for easier and effective steering of the technology in a particular direction than at a later stage.<sup>2</sup>

### **Bringing it all together**

Scenarios mentioned in the article above, may help in anticipating potential ethical issues surrounding the TwentePAM technology. As mentioned in

earlier discussions, emerging technologies as TwentePAM cause, roles, responsibilities, and meanings of breast cancer screening and breast cancer to change. If it is possible to conceptualize a possible shift of roles, responsibilities, and meanings of breast cancer screening and breast cancer at an early stage of a technology, the developers of the technology can anticipate on them. This is particularly applicable to PAM2, since its developers ideally want PAM to be better than conventional X-ray mammography screening, and if it is better, then it can replace conventional X-ray mammography. It is therefore recommended to evaluate all possible scenarios, and to debate with different stakeholders on the possible shifts that PAM might bring about. These debates can take place as analytic hierarchy processes (AHP) - an excellent platform to discuss a variety of aspects of an emerging technology. It is also important to address the controversy in an AHP, for it is possible that PAM causes some shifts on several aspects of the controversy. When clinical trials with PAM show that the technology is more accurate (more sensitive, higher specificity), less invasive, and preferably also cheaper than other breast cancer screening methods, PAM might actually cause a reduction in the breast cancer mortality rate. Also, if the clinical trials show that PAM is better capable of screening dense breasts than traditional X-ray mammography, premenopausal women might be included in the screening programs, which might increase the survival rate of women diagnosed with breast cancer.

### **References**

- <sup>1</sup> Boenink, M. (2010). Molecular medicine and concepts of disease: the ethical value of a conceptual analysis of emerging biomedical technologies. *Medicine, Health Care, and Philosophy*, 13(1), 11-23. doi:10.1007/s11019-009-9223-x
- <sup>2</sup> Boenink, M., Cuijpers, Y., van der Laan, A. L., van Lente, H., & Moors, E. (2011). Assessing the sociocultural impacts of emerging molecular technologies for the early diagnosis of Alzheimer's disease. *International Journal of Alzheimer's Disease*, 2011, 184298. doi:10.4061/2011/184298
- <sup>3</sup> Hilgerink, M. P., Hummel, M. J., Manohar, S., Vaartjes, S. R., & IJzerman, M. J. (2011). Assessment of the added value of the Twente Photoacoustic Mammoscope in breast cancer diagnosis. *Medical Devices (Auckland, N.Z.)*, 4, 107-15. doi:10.2147/MDER.S20169
- <sup>4</sup> Interview with ass.prof. dr. Hummel (2014, March 18)

# Recommendations

---

RYANNE DE BOER, RUUD VAN LAAR, PETER BINIPOM MPUAN

Currently, TwentePAM has some technological and economical drawbacks. As explained in the article 'What is holding the TwentePAM back?' the technological drawbacks concern detector sensitivity, data processing, and ergonomics, while the economical drawbacks concern lack of financial support to start clinical trials. Clinical trials are necessary to show the diagnostic accuracy and potential of the device. If it is possible to overcome these disadvantages, TwentePAM will have some specific advantages over traditional X-ray mammography. The technology uses laser light and ultrasound to create an image of the breast, and thus leaves out the ionizing radiation used in X-ray mammography, and the external contrast agents used in MRI. Photo-acoustic (PA) imaging focusses on visualizing the vascularization in the breast, leaving out breast density as a limiting factor of imaging, as it is in X-ray mammography. Thus, TwentePAM is more sensitive in imaging dense breasts than X-ray mammography is, which calls in favour of women under age 50 to be included in screening programs. This group of women tend to have denser breasts, as shown in the article 'Breast cancer controversy'.

This can be the real difference with PA-imaging in breast cancer screening. With including women from age 40 years old, since breast density is no longer a limitation of the imaging technique, a number of late breast cancer diagnosis can be prevented, or at least be diagnosed at an earlier stage. Also, with PA-imaging being less harmful than X-ray mammography and MRI, more women might be attracted towards breast cancer screening.

As concluded in the article 'From scientific research and technological development to a better product for the clinic' it is inefficient to conduct the research at 2 different institutions. As long as no collaboration is found with 'The big boys', there is no other way to do the research. This means the involved staff needs to keep a clear demarcation between research at the one hand and development at the other. Clear communication and keeping an overview of what is happening are key factors in keeping control over the demarcation.

In 'Reading the big boys' minds' we looked at how researchers should approach a collaboration with large companies. The current way of communication has not been very effective and we could conclude a more aggressive way would get more attention. With a clear distinction between the university's goal as a research institution on the one hand, and the industry's interest in developing technology on the other hand, would boost more collaboration between the two. This means the technology has to show itself as a true competitor for currently available techniques.

The diagnostic accuracy of TwentePAM must be shown with results from phase 2 clinical trials. As explained in 'What is holding the TwentePAM back?' these scientific results have to be collected in testing the device on healthy and unhealthy volunteers. For these projects a lot of money is needed, and since the TwentePAM project is heading more towards a clinical environment than towards an academic environment, it seems useful to consult funding institutions for medical research. ZonMW is such an institution, and as a subdivision of NWO and the Ministry of VWS, it supports "health research and stimulates the use of knowledge developed to help improve health and healthcare in the Netherlands."<sup>1</sup> We would advise to focus on these kinds of medical institutions to apply for funding for clinical trials, rather than to institutions that focus on technological research.

As has been outlined in the forgoing series of articles, the process of innovations gaining stability and acceptance is a mix of various factors. Apart from the need to hone the technical characteristics and functions of the TwentePAM device, we believe that a more socio-political approach will enhance the prospects of the technology in gaining acceptance and stability. Specifically, there is the need to stimulate political debate over the TwentePAM. Arguing from Van de Ven (1986)<sup>2</sup>, the TwentePAM has already achieved repute as a potentially disruptive technology with a lot of intra- and international networks - two prerequisites for attracting political debate and eventual legitimation. In view of this, we recommend that the researchers and staff involved in the development of this technology arouse the interest of politicians, science community, industry, general public, and other important stakeholders in the health care system to engage in discourse over the prospects of the technology.

In the analysis of the mammography we learned that researchers cannot control the socio-political value of a technology. In order to measure this value, such that the developers can anticipate on it, studies in the social sciences should be performed on the desirability of TwentePAM, determining what the next steps are to take in achieving social desirability.

This can be achieved with performing an analytic hierarchy process, in which not only technological and economic aspects will be evaluated among the stakeholders, also sociocultural aspects can be addressed. In combining these soft, sociocultural impacts with the hard impacts (technological and economic), a more broad perspective of the technology will be created, in which not only the diagnostic accuracy and costs are highlighted, but also the social desirability, changing roles, responsibilities, and meanings of breast cancer and breast cancer screening. These ethical aspects would shift the TwentePAM from the medical and physics field to the field of responsible innovation. Research in Responsible Innovation creates scenarios to evaluate all perspectives on an emerging technology, with which it tries to find effects of the technology that were not foreseen by its developers. With these unforeseen effects, new possibilities as well as limitations may come up. When these arrive by means of scenarios, the developers of the emerging technology have the possibility to go along with them, thereby improving their technology and/or strategy.

With the AHP, the views of these stakeholders can be measured and the level of support available to the researchers in their quest to develop this technology accurately measured. This has the possibility of opening opportunities to the research group to gain partnership with other developers in academia and industry as well as gain funding. Also, it will have a transformative effect on the views of society and provide a threshold for the easy integration of the technology into the healthcare system once its design is stabilized.

An evaluation of this kind is of most value when it is performed independently. This can be achieved by setting up a small symposium, which allows the researchers to inform the experts (stakeholders) about the technological and scientific background of the TwentePAM. This set-up is similar to an analytic hierarchy process, with the addition of the ethical aspects as described above in the different scenarios. Independent research will lead to information with higher reliability on TwentePAM's potential, which by itself can lead to a larger interest of the medical industry than research results performed with a somewhat pre-informed expert panel.

The expert panel consulted in the above suggested evaluation form is indirectly asked to formulate an answer to the question 'Is it actually realistic to expect PAM to replace conventional X-ray mammography?'. This question reflects the aim of prof. Steenbergen and his research group towards TwentePAM, and is therefore the most interesting question to ask. With different scenarios, this desirability can be evaluated, together with an option for TwentePAM to be an add-on to the traditional screening programs.

In conclusion, we advise prof. Steenbergen and his research group to re-evaluate the added value of the TwentePAM, as performed in 2011 by Hilgerink et al, with independent stakeholders. From this moment on, the focus should be on showing the importance of breast cancer screening in women between 40-50 years old. This would cause a demand for screening devices that can accurately screen these women. With this need for a new technology, applications for funding at medical research institutions as ZonMW are more likely to succeed. This would create the opportunity to start phase 2 clinical trials, which in turn may lead to convincing scientific results to show the medical world the actual benefits of PA-imaging over conventional screening methods as X-ray and MRI for the target group of women under 50 years old.

## References

<sup>1</sup> www.zonmw.nl

<sup>2</sup> Van de Ven, A. (1986) "Central Problems in the Management of Innovation," *Management Science*, vol. 32, no. 5, pp. 590-607

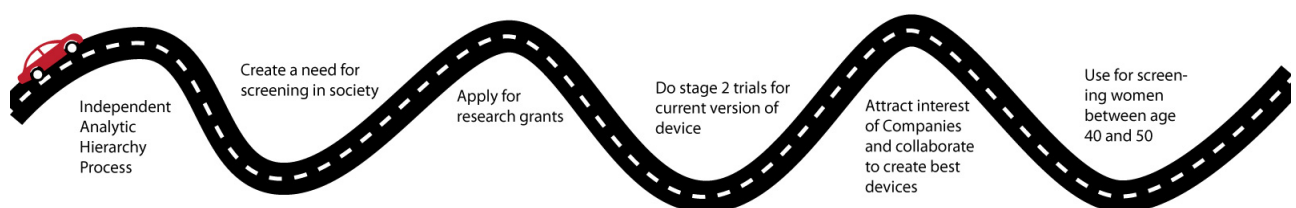





# EXOSKELETONS AND THE INTRICACIES OF MODERN TECHNOLOGY

A magazine about the design of an  
exoskeleton, and its technological,  
social and ethical context.

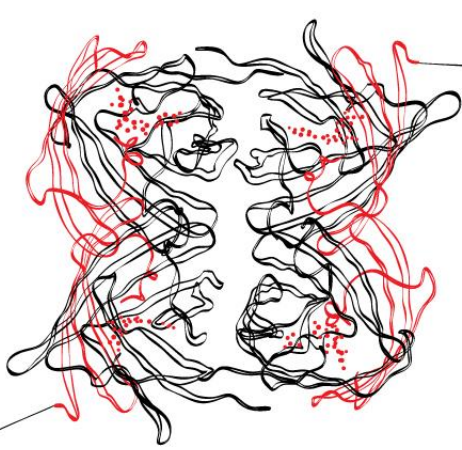
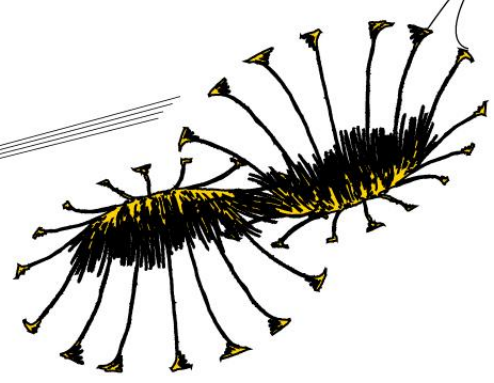

Wouter van Dijk – s1090623  
Pieter van den Bosch -s1220373  
Savvas Kikidis – s1468960  
Niels van der Vlugt – s0206113  
Supervised by Prof. M. Boon

**UNIVERSITY OF TWENTE.**



## Introduction

Dearest reader,

The magazine you are holding in your hands right now is written to show you the process that technology goes through from an initial idea, an innovative dream or simply a sketchy drawing on a napkin, to a finalized product used by all kinds of different people. However, in the current day and age technology is seen in as many ways as there are eyes to look upon it. It is seen as something practical and usable, something used to enrich our lives, simplify tasks, help us getting by or provide information. Technology is seen as something made by scientists in laboratories, by inventors in backyard sheds, by industrialist in factories. Some see technology as an evil that should be avoided and others as something that can help us achieve meaningful lives. All these different views and opinions raise questions: what is technology used for? Why do we use technology? How is technology developed? How is Technology implemented in everyday life? Answering all these questions is easier said than done, for every answer found just as many questions are raised. Clearly, when thinking of technology none of the descriptions or questions above is adequate in describing or explaining the influence technology has on its own, rather we need to take into account all of these views and problems to illustrate the true face of technology. To this end this magazine is written, it will guide its reader through the process a new technology undergoes from idea to finalized process, and along the way asks ethical and philosophical questions that transcend design and implementation. This magazine will however not focus on Technology (with a capital T) as such, but rather on a palpable example that will allow us writers to study the intricacies of technology in modern day society from a an empirical point of view.

The University of Twente's slogan "High Tech, Human Touch" seems perfect to summarize all of the above. So where better to start then at the University of Twente trying to find a technology that will allow us to study all complications and questions surrounding new technologies?

The Lower extremity Powered ExoSkeleton (LOPES) is a newly developed exoskeleton at the University of Twente that will help rehabilitation patients recover from injuries such as spinal cord lesions. By studying the LOPES project in this magazine we hope to give our readers a clear insight into all the complications and intricacies that surround new technologies and in particular exoskeletons in our society.

This magazine will first introduce the reader to the concept of exoskeletons, their history, and what they are able to do. We will then explain how the LOPES was created, followed by an explanation of its more technical details. This is followed by a look at the relationship between therapist and patient in the process rehabilitation, and how the LOPES can influence this relationship. This is followed by a sociological analysis using the SCOT framework, which we have modified using concepts and criticisms from other philosophers and ethicists. This is followed by a more in-depth ethical analysis of the topic, and an analysis of how to improve the design process from an ethical perspective. We then take the look at the topic of safety, and how this relates to robots like exoskeletons, and close with a philosophical analysis of the technology using a framework from Andrew Feenberg.

With kind regards,

The editors,

Wouter van Dijk, Pieter van den Bosch, Savvas Kikidis, Niels van der Vlugt  
20th of April 2014, Enschede, The Netherlands.

## Who are the editors?



Ing. Pieter van den Bosch has a bachelor in Business Engineering. Besides his main interest into programming he designs software products for webshops which are sold online to more than 20 countries worldwide. Development methodologies are a big interest of him and he has graduated on the research on WEB 2.0 strategies for logistics companies.

Interests: Entrepreneurship, Design methodologies, Art, Computer Science



Savvas Kikidis holds a Diploma in Rural and Surveying Engineering and M.Sc. in Geo-Information, specialized in Water Resources Management. He worked as a freelancer Engineering for about two years.

Interests: Ethical and Political Aspects of Technology



Wouter van Dijk is a bachelor of BioMedical Engineering. This means he has a background in both the more technical aspects of exoskeletons, and the medical side of the technologies. He did his bachelor assignment in photo-acoustic and acousto-optic imaging.

Interests: Biomedical Imaging, Philosophy, Online gaming.



Niels van der Vlugt has a bachelor in Applied Physics and is currently enrolled in the Master program Philosophy of science, technology and society at the university of Twente.

Interests: Music, Movies, Philosophy.

**We hope you will enjoy reading our magazine!**



## Contents

Introduction.....	108
Who are the editors? .....	109
An introduction to Exoskeletons. ....	111
A short introduction to engineering sciences.....	114
The technical features of the LOPES .....	119
The relationship between therapist and patient.....	123
The social context of the LOPES .....	125
Ethics and exoskeletons .....	132
Comparing the design process of the LOPES with the ethics design proposed by Aimee van Whynsberghe .....	135
Business Case: Care Robot Exoskeleton .....	136
Safety and Exoskeletons.....	139
Some Paradoxes of Exoskeletons. ....	141

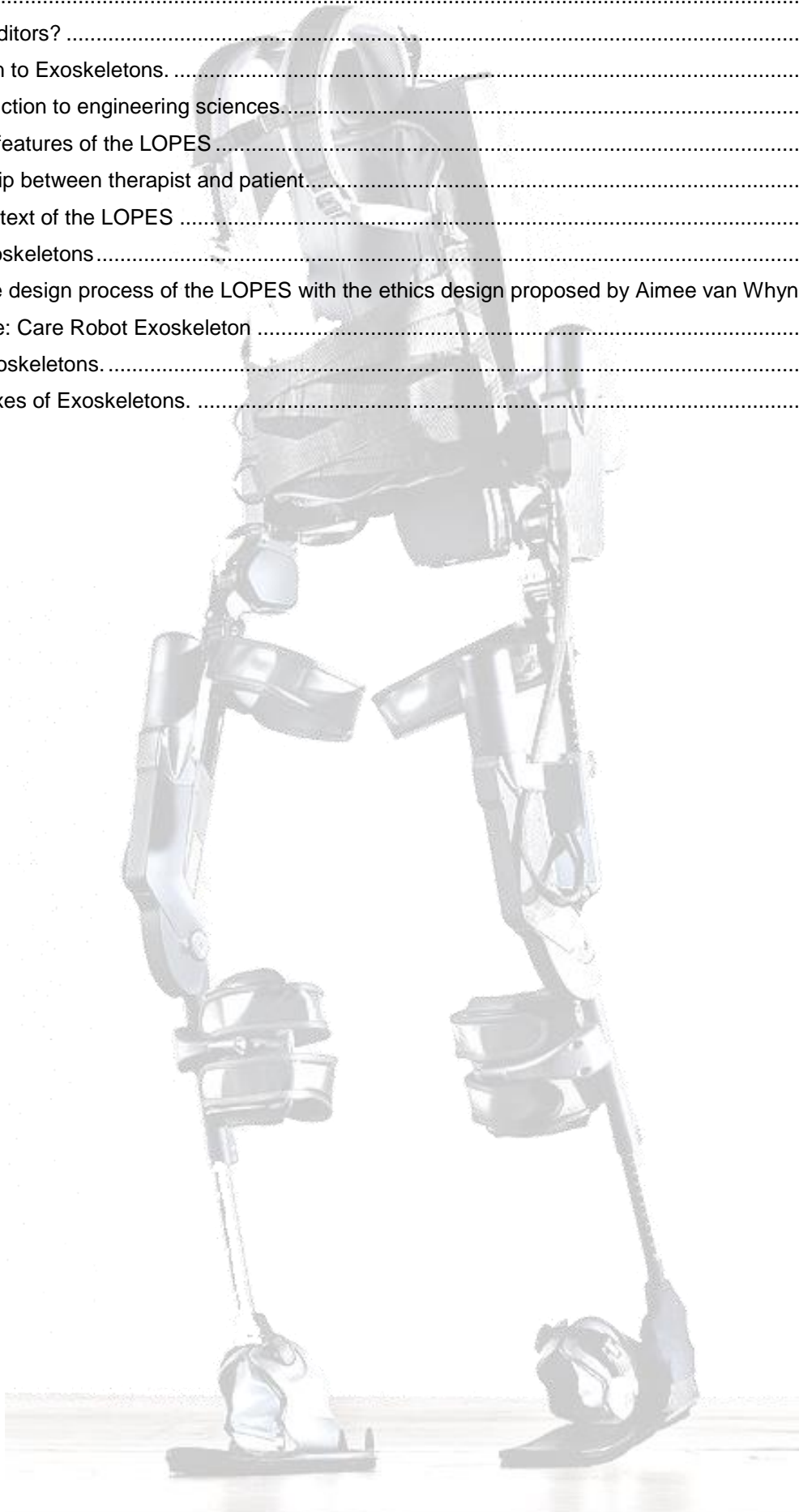

## An introduction to Exoskeletons.

### ***The limits of the body vs. the power of technology.***

Humans are vertebrates, a classification of animals that are, among other features, easily recognized by their internal skeleton. The structure of our body is maintained by our bones, and we move using our muscles. Insects however, do not have bones. They have external skeletons, usually shortened to exoskeletons. This exoskeleton provides both structure and protection to the bodies of insects.



Figure 1 Mycenaean armor (1400 BC)

Very early in our history, humans started the process of mimicking these exoskeletons. Where normal clothes protect us from the elements, our soldiers often wore armor instead. This armor has taken many forms throughout history, and was usually made out of some sort of metal, although leather and even strengthened paper have been used. However, wearing armor doesn't just protect us from enemy soldiers. The fire-proof outfit of firemen or the



Figure 3 The Iron man exoskeleton.

space-suit of an astronaut can both count as a form of protection. However, these suits have one thing in common, they restrict movement by being (at least slightly) bulky and heavy. In an entirely different field of development, transportation technology has also been a factor in human history, whether it is riding a horse or driving a car, transportation technology allows humans an increased freedom of movement.

Science Fiction writers have done something very interesting with these two concepts, they thought about what would happen if we used the engines of a car, but put them on a suit of armor instead. With this idea, the powered armor, or (powered) exoskeleton, was born. The concept can be seen in a wide variety of media, but often keeps a distinct Science-Fiction feel. One of the most iconic exoskeletons of today, though, is probably that of comic book/movie superhero Tony Stark, better known by his super hero name: Iron Man. The Iron Man suit in the movies provides Tony Stark with protection, energy blasts, and the capability of flight. As you can see, the suit seems quite heavy, but that is solved by that which makes the Iron Man suit an

exoskeleton: whenever Tony moves, his suit mimics his movements. This not only means that Tony does not need to move the weight of his suit, it also means that his strength can effectively be enhanced, by adding more power than merely that which is needed to move the metal of the suit.

Besides Iron Man, there have been many other



Figure 2 The movie aliens featured an exoskeleton designed for working in a loading bay.

variations on the theme, the classic Aliens (1986) movie has Ripley fight the alien queen in an exoskeleton designed to move loads in the cargo bay.

The movie Pacific Rim (2013) shows us the exoskeletons bigger cousin, usually known as "mecha", with incredibly large suits that mimic the pilot's movements on a larger scale.

Interestingly, most of the exoskeletons in fiction are used for military ends. Recent research however, often goes in an entirely different direction. The idea is rather simple, if Tony Stark's suit can make him strong enough to lift, say, a car. Shouldn't it be possible to construct a suit that makes someone with a muscle disease strong enough to walk around? Furthermore, instead of looking at limb movement and mimicking that, what about sensing muscle activation instead by using an EMG (electric sensing of muscle activity), so that the suit can move even if the wearer is not strong enough to move his or her limbs? In the case of someone with a severed spinal column, there is not even any muscle activation, but what about just picking up the "walk" signal in the brain and using that as a command to move around? After spending most of its time in military science fiction, the exoskeleton is entering the medical sector.

## Letting the lame walk again

Since an exoskeleton can replace muscle strength, even when your own body cannot, one of the most inspiring uses of exoskeletons is letting paralyzed people walk again. The specifics of how to do this depend on the patient. One of the possible reasons someone can be (partially) paralyzed is a severed spinal cord, this means that the mental commands to move legs never get to their destination. This means that, if we want to allow such a patient to walk again, we can't look at how he moves, since there is nothing connecting his leg muscles to his brain. What is required is a robotic exoskeleton that moves the body on its own, without requiring input from the user on what to do. However, the exoskeleton still needs to go where the wearer wants it to go, a suit that randomly starts walking around is of little use for the intended purpose, and so what is necessary is a way for the user to control the gait of the exoskeleton without using legs. One of the more ambitious ways to do this is to, simply speaking, read the users thoughts about where to walk. An example of an exoskeleton that attempts to do this is the MINDWALKER<sup>1</sup>, which is designed to use a direct neural interface.



Figure 4 The MINDWALKER exoskeleton.

There is, however, a problem. The science in Sci-Fi movies is usually advanced enough for this not to be a problem, but in the real world, size and weight of components is a real issue. An exoskeleton designed to help you walk around will need motors, batteries, sensors and a control system, as well as the "skeleton" itself, and making the suit strong enough to lift all this is easier said than done. One way to reduce the weight of an exoskeleton is to reduce the amount of functions it has. For example, our severed-spine patient can still move his arms, so a full-body exoskeleton like Iron Man seems unnecessary, we can focus our attention on the legs. Furthermore, the patient only needs to use the exoskeleton to walk, so the exoskeleton doesn't need to be capable of feats like running, or putting your feet behind your neck in an acrobatic maneuver,

so the *degrees of freedom* and *range of motion* can be limited to those necessary for the exoskeleton to walk. However, if the exoskeleton is to truly replace leg function, it still needs to be able to keep it balance correctly, and preferably allow the user to stand up not only from a sitting position, but also after a fall.

## Teaching stroke victims how to walk again

Paralyzed people are not the only people who have difficulty moving around that can benefit from exoskeletons. Victims of a stroke can require therapy to help them re-learn how to walk. In the current situation, this requires several therapists to hold and move the patient's legs for him/her, in order to familiarize the brain with the pattern of walking. In this situation, an exoskeleton and a controlling therapist can, in theory, make the process much simpler. So in order to see what kind of exoskeleton is necessary, we need to look at the patient and his/her needs. In this case, the exoskeleton once again only needs to move the legs of the patient, however, the patients can still move their legs, and the muscles aren't weakened. This means that the exoskeleton can use body movements as input. However, simply mimicking the movements of the body won't do, since the very problem is that the patient is not able to walk correctly anymore. The exoskeleton needs to be controlled in such a way that the patient receives the necessary help in walking, but if the motion is forced upon the wearer, and he/she is not allowed to make mistakes, the learning process will be hampered<sup>2</sup>. Furthermore, having an actual human controlling the walking means that the exoskeleton needs to be able to do more than

### CVA

A cerebrovascular accident (CVA), commonly referred to as stroke, is a condition in which the blood supply in the brain is disturbed. Even if a patient survives, the lack of oxygen usually has done major damage to the nervous system. This damage can show itself in many different ways, paralysis of muscles and muscle group being among these ways.

With training and time, some of the lost functionality can often be regained, due to the natural plasticity of the brain.

just "perfect" walking. Since the exoskeleton is used in therapy with a therapist, the user constantly walking around can be annoying for the therapist, and since the exoskeleton is designed only for use in therapy, it doesn't require walking either. What this means for the design of an

exoskeleton can be seen in the LOPES exoskeleton<sup>3</sup>. Instead of walking around, the exoskeleton simply

<sup>2</sup> W van Dijk and P van den Bosch, *Interview with Prof Herman van der Kooij held at university of Twente, 2014*

<sup>3</sup> Veneman, J. F., Kruidhof, R., Hekman, E. E., Ekkelenkamp, R., Van Asseldonk, E. H., & van der Kooij, H. (2007). *Design and evaluation of the LOPES exoskeleton robot for interactive gait rehabilitation. IEEE Transactions on Neural Systems and Rehabilitation Engineering, 15* ( 3), pp. 379-386.

Image sources:  
[http://en.wikipedia.org/wiki/File:Mycenae\\_armor\\_1400BC.jpg](http://en.wikipedia.org/wiki/File:Mycenae_armor_1400BC.jpg)  
[http://www.masculinity-movies.com/wp-content/uploads/2010/10/Iron\\_Man\\_movie-203x300.jpg](http://www.masculinity-movies.com/wp-content/uploads/2010/10/Iron_Man_movie-203x300.jpg)  
<http://www.ien.com/uploadedImages/ien/IENblog/AliensPowerLoad.d.jpg>  
<https://mindwalker-project.eu/>

<sup>1</sup> MINDWALKER Project Portal. Retrieved 04-04-2014, 2014, from <https://mindwalker-project.eu>

uses a treadmill, and since the patient is stationary, the weight of the exoskeleton can be supported externally, and the motors and power source are placed separate from the exoskeleton.

### Lifting Heavy patients and moving with muscular diseases.

Besides use by patients, exoskeletons could also be used by the care-giver. A nurse, for example, is often expected to lift patients, who can be quite heavy. If a nurse is not physically powerful, he or she will have difficulties fulfilling this task. One of the possible solutions to this problem is to use a mechanical lifting device, but there are some ethical and practical problems with the use of such a device. A solution to this problem is to use an exoskeleton instead, in this case one that is actually a bit like the Iron Man suit. By augmenting the strength of the nurse, lifting even the heaviest patients becomes an easy task, instead of the tiring exercise it is right now. An example of such an

exoskeleton will simply crush the joints of the user. This means that there could potentially be a situation in which an exoskeleton crushes its user's joints, and as such needs to be designed in a way that keeps this from happening. However, this is not the only danger present in exoskeletons. If the exoskeleton does not have a large enough contact area with the user, then, what is supposed to be a gentle push, could cut into the flesh of the user, or, if an exoskeleton moves too fast, the user could be bruised as a result. There is an additional risk when deciding how the user is strapped in. If the exoskeleton is immobile, and there is an emergency situation in the vicinity (such as a fire), it is highly problematic to have the user strapped in in a way that takes a lot of time to undo.

The technology behind exoskeletons is quickly moving out of the realm of science-fiction, and into reality. They bring opportunities in a great variety of different fields, and have great potential. However, we are not there yet, the design of exoskeletons still runs into a variety of problems, like components that are too heavy, motors that are too weak, or structural design that isn't safe.

Written by Wouter van Dijk



Figure 5 The HAL exoskeleton

exoskeleton is CYBERDYNE's Hybrid Assistive Limb (HALrobot 2014)<sup>4</sup>.

Besides nurses, such exoskeletons can also be used by people with muscular diseases, who are simply too weak to walk around.

### The dangers of exoskeletons

An exoskeleton is designed to help the user move his or her body naturally. However, if the designers are not careful, it is possible that the exoskeleton could attempt to move the user's body in an unnatural way. If our exoskeleton rotates our lower leg backwards, our knee will simply move, but if the exoskeleton attempts to rotate our lower legs forward, the raw power of the

#### Master-Slave "exoskeletons"

Although normal powered exoskeletons already take many different forms, there is also a type of exoskeleton that is drastically different from all other designs. These are exoskeletons that work in a so-called Master-Slave relationship. They consist of two separate machines. The "master" is what is worn by the user, and records the movements made by the user. The "slave" is a separate set of limbs that follows the movements of the "master".

These machines, which usually fall under the moniker of remote manipulators, are used in a variety of contexts. Among them are telesurgery, where a surgeon controls the master and the slave does the operation, and the handling of hazardous material, such as in radioactive experiments

<sup>4</sup>HAL (robot). Retrieved 04-04-2014, 2014, from [http://en.wikipedia.org/wiki/HAL\\_\(robot\)](http://en.wikipedia.org/wiki/HAL_(robot))

Image source:  
Source:[http://en.wikipedia.org/wiki/File:Hybrid\\_Assistive\\_Limb.jpg](http://en.wikipedia.org/wiki/File:Hybrid_Assistive_Limb.jpg)

## A short introduction to engineering sciences.

Now that we have a basic understanding of the possibilities of a robotic exoskeleton we can have a closer look at a design process and an actual development of such a robot. This part of the magazine will introduce you to researchers developing an exoskeleton named LOPES. From an engineering perspective it will become clear what their role is in actual engineering sciences and their role as researcher. Moreover, in this article several concepts of 'development methodologies' and 'best practices' of engineering disciplines are explained.

First we'll answer what is engineering sciences? The engineering sciences strive through modeling to explain, predict or optimize behavior of devices, processes or the properties of device materials. Theories and models represent the knowledge produced which in turn can be used for how the world is and how to put things to practical or technological use e.g. in development. Scientists do two things simultaneously, they search stable objects (phenomena) and they aim to find out how to intervene with these objects by modeling. This means that it is done by means of scientific research into phenomena that belong to functioning (and dysfunction) of technological devices processes of materials. Our article suits to scrutinize a case in the engineering sciences and give a detailed insight into development methodologies. Keep in mind that overlapping methodologies in natural sciences (For example chemistry, biology, earth science, astronomy, and physics are all part of natural sciences) and engineering sciences can exist.<sup>5</sup>

### Development of LOPES

At the University of Twente a robot exoskeleton (called LOPES) is being developed for rehabilitation purpose<sup>6</sup>. People who have had a severe stroke and as a result of that lost their ability to walk can be taught to walk again with this project. In this section of our magazine we shall also introduce you to the team working on this novel project.

Research and development of the LOPES initially started at the University of Twente and is guided by Prof. van der Kooij. However, the robot is now also being put into practice at the Roessingh rehabilitation center situated in Enschede. Prof van der Kooij was kind enough to provide an interview to gain insights into his project and its development. What makes the interview very interesting is that it explains how a robot is built in the lab and how it will receive feedback from its users. We were particularly interested in technical

<sup>5</sup>Boon, M., (2011) *In defense of Engineering Science: On the Epistemological Relations Between Science and Technology*, *Techné*, 15 ( 1), pp. 49-71.

<sup>6</sup>Lopes. (n.d.). Retrieved April 5, 2014, from <http://www.utwente.nl/ctw/bw/research/projects/lopes/>

development, the funding of this project and how knowledge was gained on a scientific level in order to build a practical solution for business or in the medical sector.



Figure 6 Prof. Herman van der Kooij

### The patients problem explained

We can now ask ourselves: Why and when will I need the LOPES?

To explain what the main problem for an patient is, imagine the following: during a stroke brain cells can die rapidly, in the worst case abilities or functions controlled by that area of the brain are lost. In most cases these functions include speech, movement, and memory. The way a stroke affects you depends on the area where the stroke occurs in the brain and how much of the brain is damaged. It can often occur that the ability to move will be lost and thus disabled people require to learn how to control their limbs again<sup>7</sup>. But how can you learn walking again and in which way can a treatment offer the specific support that is required to do so? Does a patient have to depend on a therapist or are there alternative ways? What are the most important difficulties in the process of rehabilitation?

In practice normal rehabilitation therapy of stroke patients can be very labour intensive. Several therapists are necessary to help the patient move his or her legs correctly, and this process is physically exhausting. The LOPES can offer an alternative treatment which can reduce the physical strain on the therapist. The robot supports the patient in the process of learning to walk again. In addition to this, the LOPES can gather data that can support the analysis of the rehabilitation progress. The goal of the LOPES project is therefore to develop a novel approach for the design and usage of wearable robots, e.g. exoskeletons, prosthesis or other wearable (mechatronic) devices that can be used for a variety of applications, such as rehabilitation, personal assistance and human augmentation to support the disabled in the revalidation process.

### The team

We would now like to introduce the reader to the skilled team that developed the LOPES. Prof. van der Kooij was assigned as the main mentor and coordinator for LOPES. In an interview he explains to us that although not directly active in the lab, he raises funding and submits research proposals. He started his research on exoskeletons during his

<sup>7</sup>Stroke - Questions & Answers. (n.d.). Retrieved April 5, 2014, from [http://www.strokescheme.ie/articles/q\\_a.htm](http://www.strokescheme.ie/articles/q_a.htm)

Image sources:

[http://www.wetenschap24.nl/imaging/stk/wetenschap/zoom/media/wetenschap/programmas/labyrint/van-der-Kooij\\_klein/original/van%20der%20Kooij\\_klein.jpg](http://www.wetenschap24.nl/imaging/stk/wetenschap/zoom/media/wetenschap/programmas/labyrint/van-der-Kooij_klein/original/van%20der%20Kooij_klein.jpg)





Figure 7 LOPES

promotion with a walking robot called MINDWALKER, which formed a basis for future robotic products.

He was interested in “how people can stand or actually walk”. He later designed models of this process, which he could use to further design instruments that served as the basic recourses for robotic products, and from there move on to the next product. Prof. van der Kooij explains that the basic process of building a product starts with an experimental research program, which happens in the lab, then making models of important processes and functions (in the case of the MINDWALKER these were control algorithms for handling the orthosis and actuation and to support to mechatronics designed by TU Delft.) and then creating instruments to finally make the products<sup>8</sup>.

Prof. van der Kooij states that he works with a group of skilled people during development. He mentions that people who design are different from people who do the actual research. They work together but their respective disciplines differ a lot. He states that designers really “love to design” the product and therefore focus on that specific task, the researchers “love to do research” as they are best in doing that. It is very important that a dedicated team is put to a specific task. In other words, motivation and doing something that you are really passionate about is crucial for the development process.

Prof. van der Kooij pointed out that in the team of the LOPES, a movement scientist worked together with two engineers in the same room which prevented “over the wall engineering”. Together they visited a therapist. This was of great importance because the movement scientists can now have the technical support of the engineers to verify what is possible or not. Furthermore, the therapist can talk with a movements scientist to speak in his own domain of language.

<sup>8</sup> MINDWALKER EXOSKELETON. (n.d.). Retrieved April 5, 2014, from <http://www.utwente.nl/ctw/bw/research/projects/MINDWALKER/>

Image source:  
[http://news.bbcimg.co.uk/media/images/55306000/jpg/\\_55306643\\_lopes\\_0287.jpg](http://news.bbcimg.co.uk/media/images/55306000/jpg/_55306643_lopes_0287.jpg)

(We will have a specific look into the term “over the wall engineering” at the reflection part of this article).

Next in the development process, technical components were required to be designed and build. The required steps are mentioned below.

### Technical components and principles in the design

Prof. van der Kooij explains that robots that already existed on the market were ‘strong robots’ and initially based on the same pre-programmed ‘movement’ principles. However, when you look at the interaction between humans and robots, the robot actually walks and not the user. The robot is in that case in charge.

Fundamentally for learning to walk again, van der Kooij states that when you look at the learning behaviour people actually learn less if the robot is constantly in charge. He simplifies that argument with a concrete example: When people are supported when having to step over a small bump or elevation their learning process will be less productive compared to the same situation in which they are not supported when people receive support walking over a small threshold they do not learn it so well, they actually learn it faster if they are not fully supported by something.

LOPES does not pre-program the movement but allows supported forces only. Moreover, in an example scenario pointed out by Prof. van der Kooij where you would almost fall asleep because everything is done for you, will result in less efficient learning. LOPES aims to regulate these forces to solve this problem but the design in components is more complex. He refers to position vs force guided support.

### Innovation during the design

One of the innovations in the design of the LOPES is that the motors that drive the movement of the exoskeleton are not placed inside the exoskeleton, but attached remotely using brake cables, and springs. Putting the motors far away from the user decreases the weight of the exoskeleton, and allows for greater freedom of movement.

According to Prof. van der Kooij, the idea of the springs was already used in some implementations of robots invented at The Massachusetts Institute of Technology (MIT), however the team has managed to improve this concept by making usage of brake cables so that the motors could stand far away from the user. This innovation in design was invented at the University of Twente. The LOPES used standard components such as motors which were easy to obtain. However, for the MINDWALKER the team fully developed the individual components e.g. the creation of the motors. This means the motors were custom made and also implemented by the team in terms of hardware and software design. This allowed the team to fully optimize the design, namely by creating own components a developer can reach better standards e.g. less power usage, less mass, more efficient

power. How this innovation works will be explained later in the magazine.

### User interactivity and data collection

Prof. van der Kooij explains that basic measurements are “duration of walking”, “how many forces are on the users” and “walking speed”. At the moment, ten users who have had a CVA and twelve with a paraplegia are using the LOPES. The treatment was very positive, which resulted in a further development by a commercial company. The new LOPES is called LOPES TWO and this robot is being used at the Roessingh rehabilitation center. The data was also required for the further development because it gave feedback to adjust the components e.g. optimizing speed and velocity. Noteworthy, for example, is that the team found out that it took patients a lot of time to get into the LOPES. In LOPES one, patients couldn't move their arms and in LOPES TWO this was improved. LOPES TWO is more a concept of a ‘shadow leg’ and not a robot exoskeleton. The shadow legs will be connected to wires. You can therefore move more freely compared to the older model. This raises a question namely “what are the interesting challenges in the design”?

### Interesting challenges in the design process

An important challenge in design is that the team noticed that the product worked in therapy for some but didn't for others. This happens often in the medicine sector, for example medicine treatments. In that way it can be time consuming and a disappointment if the treatment is not effective.

From a psychological perspective, motivation is one of the key factors in success of the therapy. Walking ‘around’ quickly becomes boring, but people have to stay motivated for their therapy to work. “We would not state that there is a direct link between walking and intelligence but we are measuring only clinical scores such as how long people walk, how fast they walk, and how many have walked.” Prof van der Kooij explains. He also mentions that people liked it more to be touched by the robot than by the therapist because they feel too dependent on the human guidance.

Most optimal is that predictions can be made for who the treatment will work and for who not. Therefore new ideas are to implement diagnostic modes/modules, which allows to make predictions for who the treatment will and will not work. By focusing on these diagnostics modes and using these measurements the team can predict what the improvement is. The degree of aided support is normally also defined by the therapist but can now be given during diagnose. This allows for advanced personalization of the programming. However, these techniques can be ethically problematic, since they can make the moral responsibilities of the therapist shift towards the programming. An extended analysis of this problem will follow later in the magazine in the ethics part covering responsibility.

### Future development support and how is the

### research funded?

During the interview van der Kooij stated that UT does not have the financial funds to do most research. The government funded the initial LOPES project. The first development of LOPES has cost 1,5 million Guilders which was a person bound research request. The second was even more expensive but the team is now testing the LOPES intensively at the Roessingh rehabilitation center. These results are discussed in-depth in the social chapter of this magazine from a social science perspective.

### Reflection on the development

**In addition to the article of the development, we will now have a closer look into some of the development methodologies and strategies.**

To summarize: the development of LOPES started with research by Prof. van der Kooij on movement on how people can stand or actually walk. He later designed models of this process, which he could further design into instruments that formed basics for robotic products such as the MINDWALKER. The scientific based models formed the basic architecture for design on paper, which could be translated into the right tools or robot components.

*How could these models give us knowledge in development?*

In case of the development of LOPES Models could be used as epistemic tools<sup>9</sup>. The models play a crucial role in conceptualization and co-construction of different mutually developing elements that are drawn together by the model. These elements include:

- (1) The epistemic aim of the model often a scientific question or problem. In this case, van der Kooij questioned walking behavior.
- (2) The idealization or simplification of the problem to make it manageable or workable. In this case, the specific context of concepts of walking and the selection of most important elements.
- (3) The target phenomena into which the original problem is translated. In this case robotically systems that has to be designed.
- (4) the particular representational means with which the imaginary or hypothetical target system is present. This describes the relations of the robot.
- (5) The experimental and theoretical knowledge made use of in the construction of the model. In this case the design mechanics of the model and the methodologies used in the process.
- (6) The concepts principles and conceptualizations. This can be the (to be) designed foundations in robot architecture and ultimate robot behavior.
- (7) The measurable or observable parameters which enable the coordination of the model with real systems. The epistemic value of the models lies in the

<sup>9</sup> Knuutila, T. and Boon, M. (2011) *How do models give us knowledge? The case of Carnot's ideal heat engine*, *European Journal of Philosophy of Science*, 1 (3), pp. 309-334.

process of modeling (e.g. creation of systems and theoretical concepts and principles) In LOPES these elements contributed to test and prototype supported walking. In that process designers and scientists worked together and both consult a therapist to gain requirements, which was crucial in the engineering process for the implementation of improvements. Figure 8 shows a simplified schematic overview of this development.

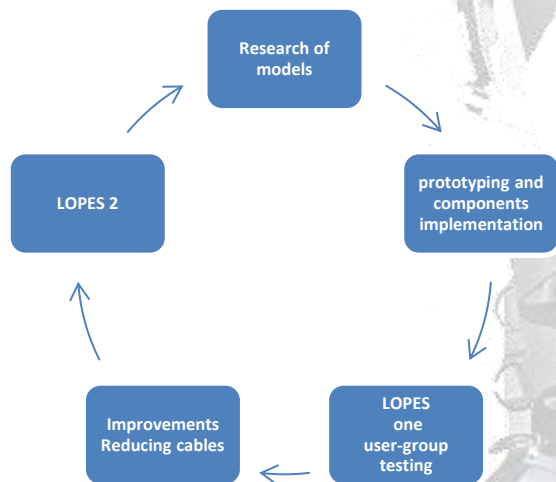

Figure 8 A schematically development overview of LOPES.

Prof. van der Kooij mentioned that not only technical people were involved in the development but also therapists and a movement scientist. This prevented “over the wall engineering”. Specifications could now be more easily gathered and incorporated by using direct feedback of the developers who could not speak the language of the therapist but were aided by the movement scientist and vice versa.

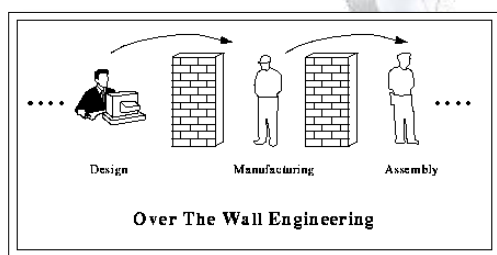

Figure 9 Over the Wall engineering figure

Often in “over the wall engineering” products get vague requirements because designers don’t know the necessary specifications for assembly (there is a certain blind spot, see figure 9). These are either not communicated by the management or the different teams mostly in another department.

**What are possible options to speed up development?**

Over the wall engineering can slow down the progress of the product development and it is therefore necessary to gather feedback during development. However, there are more methods. A big important difference between LOPES ONE and LOPES TWO is

that LOPES TWO was more backed up by a commercial company and stakeholders. Let us explain the consequences more specific: not only the company funded 50% of the development which resulted into a financial injection and therefore eased the development costs, it also motivated the developers to reach their goals because stakeholders can steer development if required. This allowed for example to focus more on redesign on the work that was already done and improve the cable systems in future versions<sup>10</sup>.

By using crucial feedback from Roessingh and the commercial company the design scope gets broader (and in that sense more complex) but in return the direct feedback will contribute to the success of the LOPES allowing faster iterations of development (what more this contains will be detailed explained in the chapter “Comparing the design process of the LOPES with the ethics design process proposed by Aimee van Whynsberghe”)

We conclude that the success of a product can be related to the actual introduction time of the product dependent on a successful collaboration. A product that is too late introduced can lose its values due to similar products of competitors.

Figure 10 on the next page shows how a early introduced product (TTM1) with very high costs can result into more profit than a product with lower costs but which took longer to be introduced TTM (2). It is therefore essential that during development of LOPES companies are involved within the development.

After the next chapter we will in detail illustrate the collaboration of institutes that influence the development.

<sup>10</sup> Veneman, J. F., Kruidhof, R., Hekman, E. E., Ekkelenkamp, R., Van Asseldonk, E. H., & van der Kooij, H. (2007). Design and evaluation of the LOPES exoskeleton robot for interactive gait rehabilitation. *IEEE Transactions on Neural Systems and Rehabilitation Engineering*, 15 ( 3), pp. 379-386.

Image sources:  
<http://www.eil.utoronto.ca/profiles/Gupta/HTMLVersion/appendix-a.fm.figure.id.1.gif>  
[Http://upload.wikimedia.org/wikipedia/commons/b/bf/Time\\_To\\_Mark.et.png](http://upload.wikimedia.org/wikipedia/commons/b/bf/Time_To_Mark.et.png)

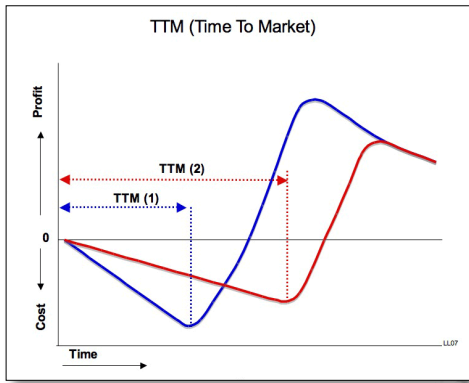

Figure 10 Time to market.

Source:

Written by Pieter van den Bosch

Want to know more?

LOPES in the media

- <http://www.hartvannederland.nl/nederland/overijssel/2011/robot-is-doorbraak-in-revalidatie/>  
<http://www.youtube.com/watch?v=npQgn11EGml>

Interview with Prof. Herman van der Kooij

Interview was held on 8<sup>th</sup> of January 2014 at Ringhorst



## The technical features of the LOPES

When you look at the philosophical aspects of a technology, as well as its societal context, it is vital that you have a good grasp of just what it is you are trying to understand. While the concept of an exoskeleton may seem simple, a more in-depth study can show intricacies and difficult choices in every part of the design. However, to truly understand every part of an exoskeleton like the LOPES would go far beyond the scope of this magazine. In order to strike a balance, we shall provide a short explanation of some of the more technical details of the LOPES, without getting caught up in specific jargon and attempts at complete explanation.

### Types of control

A robotic arm can be controlled in several ways. In industrial applications, robotic arms are often position controlled. This means that the programming of its motors is done in such a way that the arm is set to a specific position. Its rough opposite is a force-controlled arm, which is designed in such a way that a force moves against the arm, roughly analogous to what we would consider normal “pushing” of things. Position control can be achieved in multiple ways. One of these is to have very tight allowances for the movement of the robotic arm. An example of this is a see saw. No matter with how much force you press down with, the see-saw stops when it hits the ground, since these are the end-points included in the design of the device. However, such a rigid approach wouldn't be very useful in the case of an exoskeleton like the LOPES, since the human motion does not always move its limbs to their natural “end-point”.

### Control modes in the LOPES

During the design of the LOPES, the designers decided that they needed to include both a “patient-in-charge” mode, and a “robot-in-charge” mode. Roughly speaking, in the “patient-in-charge” mode, the patient wears the LOPES exoskeleton and walks on the treadmill, and is only minimally assisted by the LOPES, the optimal result being that the exoskeleton is not felt at all. The “robot-in-charge” mode is its opposite, in this mode the exoskeleton is the one moving the patient around. The LOPES also has a third function that is somewhere in between. The “therapist-in-charge” mode allows the therapist to modify the interventions that the exoskeleton makes. The inclusion of these three possible modes of use meant that there were several requirements that the LOPES needed to fulfil. In order to allow for a “patient-in-charge” mode, the exoskeleton needed a large amount of degrees-of-freedom in its design, so as not to inhibit the wearer. For the “robot-in-charge” mode, some form of position control is needed to move the body of the user. Finally, the “therapist-in-charge” mode requires the application of pure force on the

exoskeleton, instead of movement, so that specific types of therapeutic intervention are possible.

In order to allow for three different modes of use, several design problems needed to be overcome. Since the designers wanted to include a mode of use in which the patient could freely move, as well as a mode of use that used a form of position-control, they couldn't just limit the range of movement mechanically in order to make the exoskeleton move correctly during “robot-in-charge” mode. The solution to this problem is found in impedance control. Without resistance, if an initial force is placed upon a body, it will keep moving until it hits something, quite possibly very far away. This unbounded movement would make it rather difficult to control the position of the limbs of the exoskeleton. In daily life, this is limited by factors of resistance. In the human body for example, a combination of factors like ligaments and tendons stop the movement of our limbs. This process, when mimicked in exoskeletons, is called impedance. High impedance means that the movement quickly stops, transforming a pure force source into something more like position control, meaning that it can be used for the “robot-in-charge” mode. However, low impedance keeps the forces as simply forces, and allows the user to freely move around in the exoskeleton. However, the use of impedance control also means that the moving parts must be light-weight, since heavy objects are more difficult to stop from moving, and a higher amount of impedance would be needed for the same results<sup>11</sup>.

### Explanation of detection mechanisms.

One of the interesting parts of exoskeletons is what they use as input for their programming (the output being exoskeleton movements).

The LOPES primarily uses force measurements to determine where in the gait cycle (the walking pattern) the patient is<sup>12</sup>, but there are other exoskeletons that do such things differently, an example would be the *mind controlled orthosis and VR training environment for walk empowering (MINDWALKER)*<sup>13</sup>. Which is an exoskeleton designed to allow patients with disabilities located at their lower limbs to remain mobile. Work on the MINDWALKER is done by different groups, among them the university of Twente. The MINDWALKER exoskeleton uses the EEG or EMG of the patient to steer the exoskeleton. Since it can rely on brain activity as input, it is possible to use the MINDWALKER even when the user cannot move certain body parts at all.

<sup>11</sup> Veneman, J. F., Kruidhof, R., Hekman, E. E., Ekkelenkamp, R., Van Asseldonk, E. H., & van der Kooij, H. (2007). Design and evaluation of the LOPES exoskeleton robot for interactive gait rehabilitation. *IEEE Transactions on Neural Systems and Rehabilitation Engineering*, 15 (3), pp. 379-386.

<sup>12</sup> Veneman, J. F., Kruidhof, R., Hekman, E. E., Ekkelenkamp, R., Van Asseldonk, E. H., & van der Kooij, H. (2007). Design and evaluation of the LOPES exoskeleton robot for interactive gait rehabilitation. *IEEE Transactions on Neural Systems and Rehabilitation Engineering*, 15 (3), pp. 379-386.

<sup>13</sup> MINDWALKER Project Portal. Retrieved 04-04-2014, 2014, from <https://mindwalker-project.eu/>

By using EEG's (electronic monitoring of brain activity) the MINDWALKER tries to create a Brain-Computer Interface, in which the mind directly controls the exoskeleton. A short summary of different "inputs" for the programming of the exoskeleton now follows.

### **Force measurement**

As will be explained later in this article, the LOPES contains a system of springs that is able to accurately measure the effective power that the motors placed upon the limbs of the user. In the case of the LOPES, this information was primarily used to compensate for the variable and unpredictable behavior of the Bowden cables, but it is also available as input for other parts of the system.

### **Brain Measurements (EEG)**

One of the more interesting things about the MINDWALKER is that it is designed to work on data directly from the brain, and the end-goal of the project is an exoskeleton that walks when the user thinks it should walk. The difficulty of this can be seen by looking at the variety of groups working on the MINDWALKER. While the technique is promising, the current system requires a lot of training by the patient in a specialized VR environment.

### **Muscle measurement (EMG)**

Rather than intercepting signals in the central nervous system, if an exoskeleton is merely assistive, it is also possible to use muscle activation patterns as input for the controller of the exoskeleton. An electrode is placed upon the skin, and when a muscle starts to activate, the exoskeleton does so as well.

### **Ground reaction forces**

By measuring the forces between the ground and the user of an exoskeleton, a large amount of information about the center of gravity, balance, and gait cycle of the user can be gathered. This gathering of information can be done in multiple different ways, but some of the more precise measurements require sensors to be placed on the ground.

### **Position measurement**

Measuring the position of the arms exoskeleton can also be a form of input, this can be done in multiple different ways, for example, a camera could be set-up to identify the location of parts, but measuring the angles that every joint makes in combination with knowledge about the length of the relevant parts of the exoskeleton also works in most cases.

### **Control algorithms and their creation**

Between the input and the output comes the control algorithm, which is the programming that interprets the data, and decides on what to do next. Unlike the input and the output of the system, it is possible to have the control algorithm purely in software, and therefore, change it, by updating the system, in this way an outdated exoskeleton can be upgraded with minimal work.

While the previous section talks about "input" about the exoskeleton and the patient, the programming itself can also be seen as a form of input, the LOPES can do many different things depending on what the therapist tells it to do.

Usually, a control algorithm will attempt to make the exoskeleton follow some sort of 'model' that tells it what should happen. Such a model can be a set of mathematical equations that describe how the limbs of the exoskeleton should move when walking, acquired through a mechanical analysis of the forces in a human body. It is also possible to obtain a 'model' by using artificially intelligent neural networks that calculate it instead of following simple equations, or to create it by using mathematical approximations. Other types of models can use neurological activity in order to estimate the muscle forces about to be deployed by the wearer, taking a much more biological approach instead. These models are usually created by movement scientists, and not the engineers who create the exoskeleton. For example, in the MINDWALKER project, the Technical University Delft developed the mechatronics of the exoskeleton, but scientists from the UT worked on the control algorithms.

When the control algorithm knows what to do, it then needs to actually do that. The programming that attempt to do this is usually quite complicated, but can usually be divided into three levels, a task-level, a high-level and a low-level controller. The task-level controls all others, and tells them what to do, such as moving in a specific way. The high-level controller has to use this information to control the interaction between the human and exoskeleton, and the low-level controller stands directly in contact with the exoskeleton, and is responsible for what happens there.

In the LOPES, the highest controller observes where in his gait the patient is, the level under that uses this information in combination with the desired result to determine what to do, and the lowest level of controller directly controls the desired forces on each individual joint<sup>14</sup>.

<sup>14</sup> Anam, K., and Al-Jumaily, A. (2012). *Active Exoskeleton Control Systems: State of the Art. Procedia Engineering, 41, pp. 988-994.*

## The LOPES itself

The following section includes a picture of the LOPES, the numbered parts are further described.

### 1.The treadmill

The LOPES itself is a stationary device, but it is designed as a gait trainer. This seeming contradiction is, however, quickly resolved after taking notice of the treadmill contained in the design. The treadmill is designed to give the user a surface on which to walk, while keeping the overall machine stationary. Because the LOPES is stationary, the structure on the side of the treadmill has been used to add structural support, both for the machine, and the user. This means that besides being an exoskeleton, there is also an extra layer of support build into the LOPES, which relieves weight from the user and provides safety. The treadmill and the rest of the supporting structure are connected to the legs at the pelvis.

### 2.The robotic limbs

The “legs” of the LOPES exoskeleton are designed as light-weight, with a large amount of degrees of freedom, in order to allow for the “patient-in-charge” mode to function as intended.

The robotic legs of the LOPES were designed to mimick the skeleton of the user in its movements.

The pelvis is where the LOPES connects the body of the wearer with the fixed world, and in this joint movements in the transverse plane (right/left/forward/backward) were actuated, meaning they could be controlled by the motors of the exoskeleton. Movements up and down were merely left free, and not powered. This is slightly different from the human body, which can also rotate in this area.

In the hip, the human body can rotate in all directions. In the LOPES this was limited to, flexion and extension, as well as abduction and adduction. What this means is that the LOPES can move legs forwards and to the side, but not rotate the legs (so that your feet would point outward or inward instead of forward). Both of these movements are actuated (powered). In the knee, the human body can do both flexion and extension, and this was mimicked and powered in the construction of the LOPES, however, for reasons having to do with construction of the LOPES, abduction and adduction are possible as well.

The design team opted not to power the ankle, for both its complexity, possible pain and its relatively low importance. In addition, the designers thought that it would be simple to add something to take over this function to the LOPES, if the need arose.

An interesting fact about the LOPES is that the design of its degrees of freedom allow for instability. The balance of the user isn't enforced by the exoskeleton, but instead the user has to help in keeping his own balance, even while the exoskeleton is helping him or her walk.

The fact that the LOPES is focused on the legs means that some problems that can come up in the design of an exoskeleton did not show themselves. For example, it can be difficult to place joint external to the human body that have the same task as those placed internally, however, due to being placed on the sides of the legs, this problem did not occur with the design of the LOPES.

### 3.The Bowden cables

In order to keep the legs of the exoskeleton lightweight, the team decided to remove the motors from the exoskeleton, and used Bowden cables to connect the motors of the exoskeleton to its robotic limbs. Bowden cables are the type of cable usually used in brakes, and consist of a hollow tube, with inside it the cable. This design creates both a factor of safety, since the cables are not exposed, and allows for pushing motions as well as pulling. A simple example of a Bowden cable are the cables of the hand-brakes in a bicycle. There was a new problem introduced with the introduction of the Bowden cables, namely that the friction created by the cables is highly irregular. It depends not only on the force used, but also on the curves in the cables, which change when the legs of the exoskeleton, and therefore the cables, move. In order to solve this problem, the design included springs to measure force at the far side of the Bowden cable, at the leg of the exoskeleton. The cables were thoroughly tested in order to see if they could correctly send the right forces with the right frequencies to the legs. The cables are attached to the exoskeleton at the joints, with one cable at each side of the joint (Figure). This means that the cables only provide torque on the joint, and do not move the joint itself. In the figure you can see the springs of the force measuring system that send



Figure 11 Technical components overview

information to the controlling programs in order to compensate for the variable resistance in the cables.<sup>15</sup>

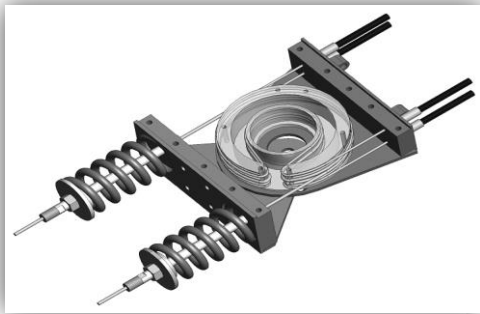

Figure 12 Design of a Series Elastic- and Bowdencable-based actuation system for use as torque-actuator in exoskeleton-type training

#### 4.The motors

The motors are the devices that power the movement in the exoskeleton. Due to their weight, they have been placed separate from the robotic legs, and are connected to them with the Bowden cables. The LOPES contains different sets of motors and gearheads for the rotations, sideways motion and forward/backward motion, each chosen for that specific use case. The motors used were commercially available, and not further modified for use.

#### 5.The patient

The patient is the person who is being treated with the LOPES, with the goal of rehabilitation. In order to accommodate the patient, the LOPES can change its height, allowing for both tall and short patients to be treated. Another choice made to increase its possible user-base was the decision not to include an ankle-joint. The ankle is a notoriously difficult part of the body to model, and without individualizing the joint it can be painful for the wearer.

#### 6.The connection

In the LOPES, the legs of the exoskeleton are attached to the legs of the wearer using wide straps at upper leg, lower leg, and just above the ankle. In the attachment of the exoskeleton, there are decisions to be made about how and where. A minimalistic approach with few straps and bonds between exoskeleton and user allows the wearer greater freedom, and it is more comfortable. However, a large contact area will spread out the forces between the body and the exoskeleton, providing safety, since it becomes more unlikely for the skin to be injured. Important is also whether or not all connected body parts are strapped in. For example, if an exoskeleton is designed to move a hand, the upper arm could be ignored, with straps at the lower arm and shoulder.

This decreases complexity but could put bigger loads on specific joint<sup>16</sup>. In the LOPES, all actuated joints were strapped in, with two straps on the lower leg, one on the upper, and a belt at the waist.

Written by Wouter van Dijk

<sup>15</sup> Veneman, J. F., Ekkelenkamp, R., Kruidhof, R., Van Der Helm, F. C. T., & Van der Kooij, H. (2006). A series elastic elastic and Bowden cable based actuation system for use as torque in exoskeleton type robots, *The International Journal of Robotics Research*, 25 (3), pp.261-281.

<sup>16</sup> Kilhyun, C., Yeonghun, K., Dooyoung, Y., Moonki, J., & Kunwoo, L. (2012). Analysis and evaluation of a combined human – exoskeleton model under two different constraints condition. *International Summit on Human Simulation 2012*.



## The relationship between therapist and patient

In the rehabilitation process for people suffering from impairments such as nerve damaging diseases like multiple sclerosis and stroke victims, patients learn to physically cope with their ailments. This learning process often is physically and mentally tiring for patients: not only do they need to (re)learn or adjust their patterns of movement, the rehabilitative process can also be confronting. The patients might need to come to the realization that he or she will never be his or her former and healthy self again. However, the patient is not alone in the rehabilitation process, the therapist is there to help. In this article, we will take a look at the relationship between the patient and the therapist, how this relationship can change when a device like the LOPES is introduced, and the viewpoint of the rehabilitation center.

### The challenging role of the therapist

Although the process of rehabilitation is taxing for patients, another problem is the strain the procedure puts on the therapist<sup>17</sup>. For example, if a patient has had a stroke, and lost the ability to walk. The therapeutic process would include carrying or lifting the patient from a wheelchair to devices such as treadmills that are used to assist the patient in the re-learning of walking. When the patient is exercising on the treadmill and trips or even falls while using the treadmill the therapists would need to catch him or her and lift the patients back to the device. After the exercises the therapist needs to carry the patient back to his or her wheelchair. Even from this simplification of the practical aspects of the rehabilitation process it becomes clear that the physical strain on the therapist could be immense.

The simple exercise described above thus requires a lot from both patient and therapist. Therapist Bertine Fleerkotte from the Roessingh rehabilitation center and Roessingh research and development describes a therapy session as follows: “[Therapists] are trained to feel what our patients feel. Our job is to help the patient walk step by step. In the end of this procedure the physiotherapist is equally tired as the patient.” (Fleerkotte, 2014)<sup>18</sup> With this she thus explains that traditional hands-on therapy requires a lot from therapeutic personnel.

### The relation between the patient and the therapist

Apart from the individual strain on rehabilitating patient and therapist a major concern is the social interaction between the two parties. This seems to be a legitimate concern and although Fleerkotte does not directly underline this problem, she does point out that the

relation between patient and therapist is of fundamental importance for a fruitful rehabilitative process. She furthermore states that the interaction between patients and therapists entails more than just physical exercises. Social and mental support, encouragement or simply a listening ear are important factors in the relationship between patient and therapist. This is further corroborated by the field of care ethics<sup>19</sup>.

Fleerkotte also points out that she thinks the relation therapists and patient have can never be fully taken over by Exoskeletons. Even though exercising is taken out of the therapists hands the full range of duties a therapist has will be enough to support the patient-therapist relation.

### The LOPES in the rehabilitation process

Rehabilitation exoskeletons like the Lopes<sup>20</sup> could prove to be a solution to the problem of prolonged and extreme physical strain on therapists. The exoskeleton, supporting patients while exercising, will, as such, relieve therapists from the duty of catching or continually safeguarding patients. Exoskeletons are also able to help in severe cases where therapists are unable to provide care due to limitations in their physical strength or endurance. Exoskeletons used in rehabilitative practices thus not only lessen the physical strain of rehabilitation on therapists, they also open up a wholly new form of rehabilitation previously unattainable due to human limitations.

With the above in mind use of exoskeletons in rehabilitation seems a positive improvement over traditional hands-on methods. However, there are also things lost in this approach to care. During the laborious process of hands-on therapy, the therapist is constantly attentive towards the patient. And if an exoskeleton takes over a large part of this process, this attentiveness could be lost. From the perspective of care ethics, this is problematic, since the attentiveness of the care-giver towards the care-receiver is very important according to this framework<sup>21</sup>. The fear is that the therapist will spend his or her time on controlling the robot, instead of focussing on the patient. From this perspective, leaving the patient and the therapist(s) alone without the intervention of an exoskeleton might be preferable, since the therapist is then attentive towards the patient. However, there is a simple counter-argument. If the exoskeleton takes away from the physical and mental burdens of the therapist, then the decrease in exhaustion could lead to a net increase of attentiveness towards the patient. Therefore, the question whether or not the use of exoskeletons will decrease the attentiveness of the

<sup>17</sup> Colombo, G., Wirz, M., & Dietz, V. (2001). Driven gait orthosis for improvement of Locomotor training in paraplegic patients. *Spinal Cord*, 39(5), pp. 252-255.

<sup>18</sup> N van der Vlugt and S. Kikidis, Interview with Bertine Fleerkotte held at Roessingh Research and Development, 2014.

<sup>19</sup> van Wynsberghe, A. (2013). Designing robots for care: care centered value-sensitive design. *Science and Engineering Ethics*, 19(2), pp. 407-433.

<sup>20</sup> Colombo, G., Wirz, M., & Dietz, V. (2001). Driven gait orthosis for improvement of locomotor training in paraplegic patients. *Spinal Cord*, 39(5), pp. 252-255.

<sup>21</sup> Tronto, J. C. (1998). An ethic of care. *Generations*, 22(3), pp. 15-20.

therapist towards the patient is rather difficult. While the physical contact with the patient will most likely decrease, the decrease in physical strain upon the care-giver could allow the therapist to improve the overall care process.

### Attentiveness and LOPES

The LOPES has different modes of operation that have a different effect on the attentiveness of the therapist. If the therapy is done using the “robot-in-charge” mode, then that means that the therapist will have very little influence over the exoskeleton except for turning it on. The effect of this is two-sided. On one hand, if the workings of the exoskeleton are automated, then the therapist can have his or her full attention on the patient, whether observing how the therapy is going, or just making small talk and building a relationship with the patient. On the other hand, this means that the therapist is not directly involved in the process of therapy, and is merely a bystander. The question then, is if it is still possible for the therapist to give competent care, if the therapist isn't involved in the process in the same way. The “patient-in-charge” aspect of the LOPES will be better in this respect, since the therapist can observe how the patient is walking, in a situation that is as similar as possible to normal walking. In the “therapist-in-charge” mode, the question of attentiveness is the most difficult. While this mode has the therapist involved in controlling the exoskeleton, the technological actions undertaken here have a different character than attentiveness through physical touch. If a therapist places all attention on the legs of the patient, then the patient still has the feeling that the therapist is paying attention, but if the therapist is busy programming the LOPES, this may seem the therapist is not being attentive. It seems that a relatively simple interface that allows the therapist to talk to the patient, and for example explain what he or she is doing, while programming the LOPES, is a good solution to this problem.

### An exoskeleton in a rehabilitation center

Implementing exoskeletons in rehabilitation centers isn't a straightforward task. They are expensive to purchase -the Lokomat (a spiritual predecessor of the LOPES) for example costs a whopping 220.000 euros-, it is bulky, and it requires expertise to work with. The first of these three problems is of course the most prevalent one when a rehabilitation center wants to implement an exoskeleton in their therapeutic routines. Funding can be hard to come by and such a big expense might be hard to justify when the actual benefit for patients has not been proven<sup>22</sup>. When the Lokomat system was introduced in Dutch revalidation centers it was funded by both the Dutch government and a collective of revalidation centers called Revalidatie Nederland<sup>23</sup>. Fleerkotte however points out

that government funding is out the question for the LOPES.

Next to the actual purchase of the exoskeleton space needs to be reserved to house and store the machine. Exoskeletons are still quite bulky and thus require substantial reallocations of space when first introduced in rehabilitation centers.

A last point of concern regarding the introduction of exoskeletons in rehabilitation centers is the fact that both use and maintenance of the machine require either retraining of personnel or the hiring of new personnel altogether.

These three points show that although the actual purchase of an exoskeleton might be funded, by, for example, Revalidatie Nederland, a lot of extra costs quickly emerge. Fleerkotte explains that this means that because regular government fundings for the rehabilitation center will not increase the cost of therapy and care will rise. Even though rehabilitation is covered by insurances in the Netherlands, undoubtedly this increase in costs will have an effect on therapy.

Assuming a rehabilitation center manages to work around the aforementioned monetary problems and installs a rehabilitative exoskeleton the question remains who actually gets to use it. In the Roessingh rehabilitation center the Lopes was initially used to aid patients with a spinal cord lesions, while future use will be focused on the assistance of recovering stroke patients.

Because exoskeletons are a limited resource in rehabilitation centers therapists need to be strict in their choice of patients. Therapists cannot simply use the exoskeleton with every patient in the hope they will show even the smallest sliver of improvement. Fleerkotte indicates that patients must have a real chance to recover fully and will be active after their rehabilitation, furthermore they are required to have an extensive social network. This means that the main demographic will be younger and middle aged patients.

### The Lokomat

Taking all this into consideration it is important to ask if rehabilitation by exoskeletons is indeed faster or better than traditional hands on care. Studies on the Lokomat exoskeleton have shown that there is no significant difference in the overall outcome of hands on therapy versus therapy with the exoskeleton. The study did however indicate that the Lokomat was more proficient in a larger set of sub training exercises<sup>24</sup>. This means that patient rehabilitating in an exoskeleton will for example improve their walking speed *and* motor functions while patients rehabilitating with traditional

<sup>22</sup> K. P. Westlake and C. Patten, (2009) *Pilot study of Lokomat versus manual-assisted treadmill training for locomotor recovery post-stroke*, Journal of NeuroEngineering and Rehabilitation, 6(18).

<sup>23</sup> L. Kok, A. Houkes and N. Niessen, *Kosten en baten van revalidatie*, SEO Economisch Onderzoek, 2008

<sup>24</sup> K. P. Westlake and C. Patten, (2009) *Pilot study of Lokomat versus manual-assisted treadmill training for locomotor recovery post-stroke*, Journal of NeuroEngineering and Rehabilitation, 6(18).

hands on methods will only show improved results in balance.

A separate study has shown that patients did prefer therapy using the lokomat<sup>25</sup>. Because of this patients might want to rehabilitate using exoskeletons, since even if they do not improve the results of the therapy, they make the rehabilitation process more comfortable.

Combining these two results could lead us to conclude that use of exoskeletons in rehabilitation might provide rehabilitation centers with a larger influx of (paying) patients.

The cost effectiveness study also shows that even though exoskeletons are shared technologies, the earlier described costs that go hand in hand with the purchase of an exoskeleton will actually make them more expensive than traditional therapy. However patients and as such insurance companies will have to pay less than they used to.

Seen from the perspective of the therapist: Fleerkotte indicates that she is of the opinion that the perceived benefits for therapist alone must be enough incentive to start working with exoskeletons in rehabilitation.

## The social context of the LOPES

Every technical device is placed within a social context, so too the LOPES. The SCOT (Social Construction Of Technology) methodology, as proposed by Bijker et al. allows us the study the LOPES in this social context and the influence of social context on its design. (Bijker et al, 1987)<sup>26</sup>. SCOT is a framework that looks at how different groups give different meanings to a technology, and how this influences subsequent designs of the technology. In SCOT this is achieved by first indicating what the different social groups are and how they are connected, after which conclusions can be drawn about closure mechanisms. These closure mechanisms then describe how and if a technology is accepted in society.

However, the SCOT analysis is not perfect. One of the objections against the SCOT framework is that it does not take into account the importance, or weight, of different social groups when the relationship between those groups, and their influence on the shaping of a technology, is studied.<sup>27</sup>. Klein and Kleinman suggest

<sup>25</sup> L. Kok, A. Houkes and N. Niessen, *Kosten en baten van revalidatie*, SEO Economisch Onderzoek, 2008

<sup>26</sup> Bijker, W. E., Hughes, T. P., & Pinch, T. J. (1987). *The Social construction of technological systems : new directions in the sociology and history of technology*. Cambridge, Mass: MIT Press.

<sup>27</sup> Klein, H. K., & Kleinman, D. L. (2002). *The Social Construction of Technology; Structural Considerations*. *Science, Technology, & Human Values*, 27(1), pp. 28-52.

a more structured approach to SCOT that will blend sociology with SCOT to obtain a more insightful look into the shaping of technology. Winner criticizes SCOT by saying that it as an approach that seems to be very academic in nature. He argues that SCOT does not take into account important real-life issues, such as ethical considerations, surrounding technology (Winner, 1993). Both Winner and Klein and Kleinman underline the importance of SCOT but suggest that important considerations that can move SCOT out of the academic domain are missing. In this article we will first follow the scot methodology to draw a picture of the social relevant groups and the way they will influence the closure mechanisms in SCOT. After this we will take note of Winner's criticism and connect SCOT with Tronto's emphasis on the importance of responsibility in the practical ethics of care. By studying how moral responsibilities are divided among the social relevant groups from SCOT we can build upon the SCOT framework and lead it into the practical domain.

### Different meanings for different groups

The social context of the LOPES is not limited to the UT and the Roessingh. There are other social groups that are relevant here, and the way in which the LOPES is situated in this network of social groups. The LOPES is still in an early stage of production, even though it has been introduced in the Roessingh Rehabilitation Center. It's not something available on the open market, and it is used as a result of co-operation between the university of Twente and the Roessingh Research and Development (RRD). However, while these two groups often work together, that does not mean that there are no differences between the groups, and the researchers within them. In order to analyse the context in which the LOPES is placed, we have identified all different relevant groups, and attempted to explain just what the LOPES means to them.



Figure 13 Roessingh logo

### The Roessingh rehabilitation center

The Roessingh rehabilitation center is located in Enschede, and was founded in 1948. The Roessingh actively treats about 700 patients a year but conducts approximately 4000 first examinations in the same time span. The center has a working staff of 560 employees, of which 25 are medical specialists

(Roessingh financiële jaarcijfers 2012, 2013)<sup>28</sup>. The Roessingh consists of a number of branches spread out over a large building complex which range from a grade school and stables to the main rehabilitation center and a research and development department. All these different branches work together to provide fruitful rehabilitation to patients of all ages and backgrounds.

The Roessingh Rehabilitation Center has as its prime target the treatment of people, and giving comfort to them and their families; however we should not forget that it still remains an institution that has to make a profit. This means that the Roessingh Rehabilitation Center must have also financial interest based upon the introduction of LOPES in the treatment that it provides.

### Vision of the Roessingh

The centre treats patients with bodily impairments ranging from lost limbs to stroke victims, these patients receive help in order to treat or cope with their ailments. The Roessingh prides itself in the personal attention patients receive from the medical personnel but also promotes group therapy and technical innovation. The combination of these three factors in the rehabilitative process at the Roessingh form an environment that is tailored to help patients get their everyday lives back on track as soon as possible.

A study from the University of Nijmegen<sup>29</sup> has shown that the presence of new and innovative technology in rehabilitative settings can be a great incentive for patients to choose that rehabilitation center over competitors. Pushing new technology into a rehabilitation center can thus be a way to attract patients that would otherwise have chosen to go to a rehabilitation center, for example, one that is closer to their homes, and therefore more accessible.

Therefore, the Roessingh wants to use the LOPES to improve their therapy and attract patients, which gives them income, however, a clunky machine like the LOPES needs a lot of space and initial monetary investment. This means, that the balance between the money that the introduction of LOPES will produce and consume will be also a factor of great importance for the introduction of this technological artifact in the rehabilitation process.

<sup>28</sup>Roessingh financial report 2012 retrieved at 04-04-2014 from [http://www.roessingh.nl/jaarbeeld\\_2012/Financiele-jaarcijfers](http://www.roessingh.nl/jaarbeeld_2012/Financiele-jaarcijfers)

<sup>29</sup> N van der Vlugt and S. Kikidis, Interview with Bertine Fleerkotte held at Roessingh Research and Development, 2014

Image source:  
<http://www.rrd.nl/>

In their test with the LOPES, the Roessingh has decided to use it for those patients who have the highest expected success rate, In the words of Fleerkotte: "it is a prerequisite that they are active and have a good social network."

### Roessingh Research and Development



Figure 14 Roessingh R&D logo

The focus on innovation of rehabilitation techniques and devices may not be unique in the rehabilitative sector but it is a factor that contributes to the high standards of care of the Roessingh. The Roessingh Research and Development (RRD) is an independent research and development organization that does scientific research for the rehabilitation center. The organization has close ties to the University of Twente, of which four Chairs are researchers at the RRD. This means that technical innovative impulse into the Roessingh comes from both the RRD itself and a number of groups at the University of Twente. Another great advantage of this close relation between the University of Twente and the rehabilitation center is that design of new technologies can be done in a mutually reinforcing and iterative manner. The direct line between the two institutions enables therapists to directly make clear their wishes and needs regarding a new technology to researcher at the university. At the same time researches at the university can inform therapists of actual possibilities. When a product is eventually developed it can directly be tested in the rehabilitation center after which flaws or shortcomings in the design can be relayed back to the university. This process ensures technologies that not only do what designers intended for them to do but also have actual application in a rehabilitative setting.

For the LOPES, the RRD plays a crucial role in the development, because it is the link between the University of Twente and the patients it wants to test on. Moreover, its experience in the rehabilitation process gives the RRD a certain amount of trust and confidence among its patients. It is important to mention that, since the LOPES is a technology that has to be tested before it goes out in public, all the aforementioned characteristics are what makes RRD an appropriate and capable partner for the University of Twente for their experimentation with, and introduction of, LOPES.

In more detail, the RRD's basic contribution to the development of LOPES is the experience and insights if its clinicians and physiotherapists, it is the people of

the RRD that attempt to prove the LOPES successful in a clinical context. In addition, the feedback from the Clinicians allows them to make sure that the LOPES is not only good for the patient, but that it is also a good tool for clinicians. It is this more personal aspect that sets this group apart from the university.

In accordance with the interview at RRD we can mention the following: the group of clinicians and physiotherapists has a very positive attitude for the introduction of LOPES in the rehabilitation procedure. Since the LOPES can reduce their work load while ensuring that the patients still receive proper care.

#### University of Twente.

University of Twente (UT) is a technical university, with as its motto "High Tech, Human Touch". This motto can be seen as an expression of the academic identity that UT tries to hold itself to. UT provides a wide range both of degree programs in many disciplines. As a manifestation of the motto of the UT, these disciplines span from social and behavioral sciences to engineering and applied sciences.

Therefore, the focus of the UT is not only to provide the academic background that is necessary for "High Tech" research. The UT is also trying to cultivate the knowledge that is needed in order to navigate this research in social and ethical terms, in other words to provide the framework that can lead to "Human Touch".

Even within the UT, the design of the LOPES takes place within a specific context. The research is not done by the entire university, but by the Biomedical Engineering Group (BEG) group, which is a sub-group of the MIRA, which is a part of the University.

The Institute of Biomedical Technology and Technical Medicine (MIRA), is a group within the UT that aims to create highly innovative technology with a focus on humans. The research and innovation that is held in MIRA is always combined with the clinical practice. In that way the applicability of any technology is tested in everyday practices. This task can only be accomplished through the close relations the MIRA holds "with hospitals, the business community and governmental organizations"<sup>30</sup>.

BEG, "carries out research concerning the treatment of impaired interaction between the nerves and skeletal muscles"<sup>31</sup>. The basic target of that group is to create novel technologies, both for patients and clinicians. The LOPES is one of the devices that the group developed. Intended as a novel technology, which can achieve better results for patients, while reducing the workload for the therapist.

This is the context in which Prof. Van der Kooij and his team operate, as described in the article 'A short

introduction to Engineering Sciences'. The university offers research grants and workplaces to Prof. van der Kooij's research group, which developed the LOPES and is currently working on the LOPES II. The meaning this group ascribes to the LOPES seems rather straightforward. The projects immediate goal is to "optimize the functional outcome of (robot-aided) gait training in chronic stroke survivor"<sup>32</sup>.

While doing this, they also look at the background of an aging population, which means an increase in patients and a decrease in available therapists, and the broader context of the LOPES is circumventing this problem. Furthermore, they are interested in research results of working with the LOPES, using them in future projects, such as the LOPES II

#### Patients

A group of people that should not be forgotten are the people being treated with the LOPES. Patients using the LOPES are very enthusiastic about the technology of exoskeletons in the rehabilitation process. This can be understood mainly due to three reasons. Firstly, the introduction of Exoskeletons is intended to improve the treatment of the patients. Secondly, it creates the certainty that they receive a high level of treatment, since they are in a high-tech environment that takes improving care with technology seriously.. Thirdly, cases that would be problematic in other cases, due to their severity, after the introduction of Exoskeletons they can also be treated.

Even though the aforementioned sentences describe well established facts, based upon the experience the RRD has up to now, we must be more meticulous in our analysis. We must not forget that there are some limitations both in the number and in the characteristics of the possible patients, who can receive treatment with LOPES up until now. One of the basic conclusions of our interview in Roessingh is that LOPES is used only in cases that the patient can regain his mobility back. As a result, the social relevant group of the patients is limited to stroke patients and patients with spinal cord diseases.

<sup>30</sup> MIRA – Biomedical Technology and Technical Medicine, retrieved at 20-03-2014 from: <http://www.utwente.nl/mira/>

<sup>31</sup> Biomedical Engineering, Neural and Motor Systems, retrieved at 20-03-2014 from: <http://www.utwente.nl/mira/scientistsusers/sro/neuralandmotorsystems/bme/>

<sup>32</sup> Laboratory Biomechanical Engineering, Research on LOPES, retrieved at 20-03-2014 from: <http://www.utwente.nl/ctw/bw/RESEARCH/PROJECTS/LOPES/INDEX.HTML>

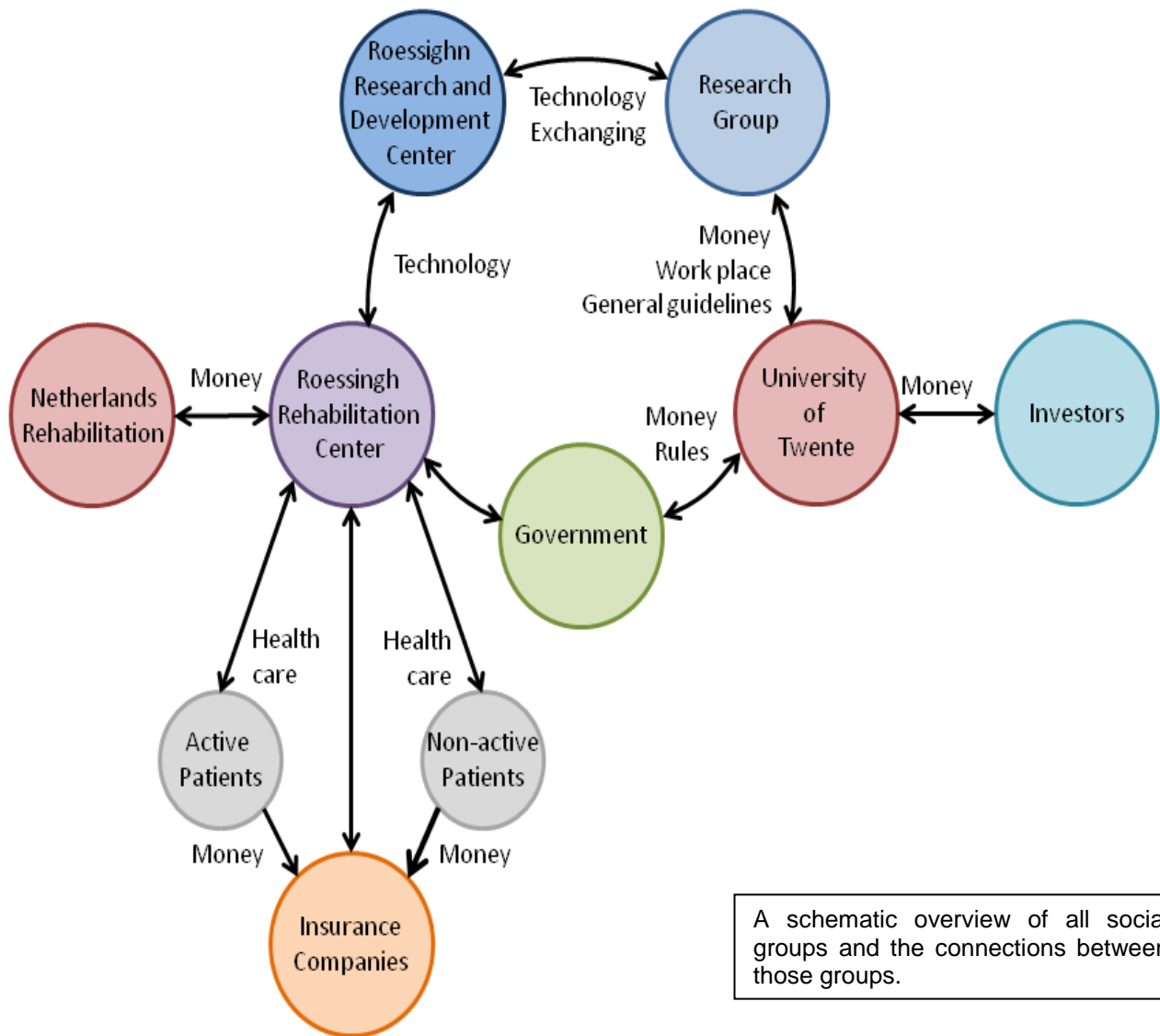

### Investors

Two different kinds of investors are relevant when looking at the social context of the LOPES. First of all, there's grants from companies and the government, which are the main sources of income for the university, and as such the research group. Companies invest in technologies they think will turn out a profit in future endeavors and government grants are provided to researchers that can show that their technologies can have a positive impact on society or show other interesting prospects.

Secondly, a monetary input may come from Revalidatie Nederland (Dutch revalidation), which is a collective of rehabilitation centers finances centers like the Roessingh, that gives grants to new or otherwise promising technologies that may have a positive impact on the rehabilitation process of their patients. The Lokomat exoskeleton was financed by the collective and the LOPES might prove to be a viable candidate for such funding when it comes out of its research phase.

### Government

The last group with ties to all others involved is of course the government that provides legislation and guidelines for the development of new technologies and implementation of those technologies into healthcare. There are currently no such guidelines for the use of exoskeletons in rehabilitation. This means that it is difficult to determine what the meaning of the LOPES or rehabilitation exoskeletons is to the Dutch government. It is noteworthy that Dutch Government is not supporting Rehabilitation Centers in making use of new technologies like exoskeletons. The ISO, the international organization for standardization has, like the Dutch government, not yet publicized guidelines for the design of healthcare exoskeletons<sup>33</sup>. Although this bureau is not a legislative organ its guidelines are respected by a wide range of countries<sup>34</sup>.

<sup>33</sup> International Organization of Standardization, Standards Catalogue, retrieved at 11-04-2014 from: [http://www.iso.org/iso/home/store/catalogue\\_tc/catalogue\\_detail.htm?csnumber=53820](http://www.iso.org/iso/home/store/catalogue_tc/catalogue_detail.htm?csnumber=53820)

<sup>34</sup> International Organization of Standardization, retrieved at 11-04-2014 from: <http://www.iso.org/iso/home.htm>

## Rhetorical Closure

With the different social groups identified we can now look at the closure mechanisms in SCOT: rhetorical closure and closure by redefinition. Rhetorical closure means that the different social groups believe that their problems with a technology are solved, sometimes through a new innovation that solves a problem, and sometimes through changing societal conditions.

As stated Rhetorical Closure can be said to be reached when all the problems that the different groups have are solved, or cease to exist for some other reason. In the case of the LOPES we have to investigate whether or not this has happened. While doing this, we have to keep in mind that LOPES is still in the procedure of testing. This means that in this early stage of research, the characteristics of the examined technology can easily change and as a result the technological artifact itself can also change.

One of the things that can come up in a new technology are growing pains. A new technology, like the LOPES exoskeleton, does not always have good standards and procedures to help with the safety of the device. These early errors can only be removed after they have been experienced. These experiences only come to light when the social groups around a technology give support to it. A good example of this is aircraft crash investigations. If an airplane crashes, investigators will immediately try to reconstruct the accident, and figure out what went wrong. Once they have figured this out, they are able to create safety regulations and update weaknesses in planes. Since the aviation world communicates these investigations clearly, a weak point that comes to light in the investigation will be quickly removed. A similar process can happen with exoskeletons, but in order for this to happen, the support base needs to be large, and communication needs to be clear. Something like this can be seen in the communication between the Roessingh and the University, although the scope is still very small.

The University of Twente (UT) in general, but in more detail, the Biomedical Engineering Group (BEG), as a part of MIRA and the UT, has a strong interest to keep on working in this field. It is a field where technical innovation and a human touch are combined. To the university, the research is attracting financial attention from companies, and can be seen as a fertile ground for future research, in accordance with the "High Tech, Human Touch" slogan.

The Roessingh Rehabilitation Center and the RRD are also on the same track. Most of what we have said about the UT can also be extended to the Roessingh. In addition to that we have to emphasize once again that the Roessingh can also benefit from the technology in the long term, by creating the image of an innovative rehabilitation center, which can allow it to make more money through attraction of new patients.

The group that has to be taken under elaborate consideration is the groups that are not focused in the

creation of the technology, but in the use of this technology as clinicians and also patients in the rehabilitation process. In this point we can say that the technology of Exoskeletons, examined through the example of LOPES in the Roessingh Rehabilitation Center, seems to have reached rhetorical closure, since the creators, the clinicians, and the patients do not seem to have a problem with the introduction of Exoskeletons in the rehabilitation process.

But once again we have to repeat that LOPES, and Exoskeletons in general, are in the phase of testing. The question is if this equilibrium point between the needs and problems of the different social relevant groups should be considered as an unquestionable fact, or we should be careful because in the long term, frictions that are unnoticeable now, can come up and interfere with the development of exoskeletons. For example, therapists that are less innovation-friendly than they are at the Roessingh might have a different opinion once they get in touch with the technology.

## Closure by redefinition of the problem

Closure by redefinition of the problem means that a technology is stabilized by the invention, and subsequent solving, of a new problem. If this new problem is seen by all relevant groups as more important than their old problems with the technology. An example would be if patients, therapists and designers all had different opinions about a specific part of the LOPES for reasons like aesthetics, comfort or mathematical simplicity. Such a problem could be hard to solve for all groups, but if subsequent research shows that there is something more important, for example; safety, that can only be solved in a specific way, then all groups would agree that the safest solution for the part they used to fight about is the best.

Closure by redefinition is a continuous process. This means that even though in some cases we can come up with a technology or technological artifact that can be said to be state of the art, we should not reject future improvements and changes. Especially in our case, when LOPES and Exoskeletons come out of the laboratory testing and be introduced to the public, there will be a plethora of interactions. An ever increasing number of patients will mean an ever increasing number of experiences. This experience will also produce a vast amount of user data, and this can be used to further improve and develop the technology.

But what we have to keep in mind are the basic contributions of the LOPES to the technology of Exoskeletons, and its basic advantages in comparison with other Exoskeletons. In this content, and as it was emphasized in our interview at RRD, the "assist as needed" algorithm can be seen as an innovative change. If the results of testing procedure turn to be good, and there is a plethora of reason to be optimistic about that, even though not absolutely sure, then we can say that we reach a limited closure by redefinition in the case of LOPES. This conclusion is based on two

reasons. Firstly, if the change of algorithm produces a good result, then different research initiatives (Lokomat is such an example, as it was pointed out in our interview at RRD) without these results up till now will move one step closer to the adoption of the “assist as needed algorithm”. And last but not least, the adoption of this algorithm maybe turn out to be the needed impetus for the introduction of Exoskeletons in the rehabilitation process in general, which will give a new impetus to future developments in the field.

### Responsibility

We will now take a look at responsibility, and how it is distributed amongst the different social groups. In care ethics, responsibility is an important aspect of care<sup>35</sup>. Tronto suggests that in order for the care relationship between therapist and patient to be good, the therapist must be responsible for the patient. However, the introduction of robots like the LOPES exoskeleton, can shift the responsibility for the patient. If something goes wrong in a traditional therapy, for example, there is an accident and the patient has a heavy fall, the responsibility lies with the therapist. But what if there is a problem with the LOPES? The therapist should still be in charge of the therapy, but if there is a mechanical problem, or a bug in the programming, or even if the programming is working “as intended” but not in a way which is good for the patient, is the therapist still responsible? Some people might want to assign this responsibility to the LOPES itself, since the LOPES replaces the task of the therapist. However, since the LOPES is a robot, it is disputable whether or not it is able to take moral responsibility, since in order to have moral responsibility there must be a moral agent that is responsible. There are different conceptions of what a moral agent is, but van Wynsberghe<sup>36</sup> argues that in none of them, robots can take responsibility, since they lack their own intentions, and it is impossible to hold a robot accountable for its actions. There are of course, as in almost everything philosophical, philosophers who disagree.

So the question is, if the LOPES cannot be held responsible if something goes wrong, then who can be? One of the ways to look at it is to say that the therapist mishandled her tools. It isn't that strange to hold a physiotherapist responsible for what a robot does. After all, if a therapist asks a patient to stand on a ladder during therapy, and the ladder breaks, it seems logical that we blame the therapist for using faulty tools. But on the other hand, it is also rather

strange to hold that there is no difference between a faulty ladder, and, for example, a bug in the programming of an exoskeleton, that does something which hurts the patient. For example, an assist-as-needed program could accidentally deliver too much force in a very specific and rare situation, leading to injuries to the patient. If there is something wrong with the exoskeleton, then is it the University of Twente that is responsible, since they are the ones who developed the LOPES exoskeleton? They have the most insight into the design process, and understand the device in ways that other groups can't. They have far more power to influence the design of the LOPES than the therapist. Or is it the Roessingh Rehabilitation center, which is the facility where the accident happened, and who decided to use the LOPES? It is this group that obtained the LOPES for the therapists to use after all. Apparently the device was not perfectly safe, and it is their responsibility to protect their patients. A simple *no* from the Roessingh when acquiring the LOPES would have been enough to circumvent the accident. Or is it more precisely the Research and Development center that is responsible? They are the group responsible for the integration of the LOPES, so doesn't that mean that they have made sure that nothing could go wrong? Or is it the government that didn't check the safety issues involved, and is their lack of regulation the real problem. Even if one of the other groups is at fault, it is the government that is able to force these other groups to follow procedures that can stop these mistakes from happening. While the government has not used its power to influence the design of the LOPES, the very point that they could have done so but didn't can be seen as a form of negligence. Another group that has influence on the other groups is that of the investors. Much like the legal power of the government, an investor can demand influence on the process of the design, and an organization like Revalidatie Nederland can use its funding to support a specific design choice, since it is difficult to adopt the use of exoskeletons without their financial help.

### The issue of Moral Responsibility in the LOPES

We have seen that it is problematic to hold an exoskeleton like the LOPES responsible, and also that it is difficult to assign responsibility to a specific group. Furthermore, from the care ethics perspective, it is the therapist that should be the one responsible in the practice of care. Therefore it would be preferable if the LOPES was made in such a way that the therapist is not only responsible, but also in control. This can be done by influencing the design, and use, of the LOPES. For example, as we saw in the ‘The technical features of the LOPES’ article, the LOPES exoskeleton has multiple modes of use, and the moral responsibility can shift along with the mode of operation of the LOPES. As elaborated upon earlier

<sup>35</sup> Tronto, J. C. (1998). *An ethic of care*. *Generations*, 22(3), pp. 15-20.

<sup>36</sup> Van Wynsberghe, A. (2014). *To delegate or not to delegate: Care robots, moral agency and moral responsibility*. abstract accepted for the AISB symposium “Machine Ethics in the Context of Medical and Care Agents”, AISB-50, 1-4 April 2014, Goldsmiths, London, UK.



the technical description of the LOPES, there are several different modes of use in the LOPES, the “patient-in-charge” mode, the “robot-in-charge” mode, and the “therapist in charge”.

In the “robot-in-charge” mode, the LOPES moves a passive subjects legs around, in a pre-programmed manner. The therapist puts the patient in the exoskeleton, but has little further input on the therapy. If there is an accident during the therapy, it is difficult to assign responsibility. While the therapist is the person who assigned the therapy to the patient, it is difficult to assign full responsibility on the therapist, since there is little input on the actions of the LOPES. This means that, while it may seem a good idea to use this mode from a technical perspective, an analysis based on van Wynsberghe’s framework tells us that it can be a bad idea from a different perspective.

The “therapist-in-charge” mode is much less problematic from an ethical perspective, but still complicated. In the most pure form of this mode, the therapist is able to specifically program what the LOPES does, up to the specific forces on the patient. This level of control is rather like what can be expected of a normal therapy, in which the therapists move the legs of the patient themselves. If the LOPES simply follows the instructions of the therapist to the letter, then all responsibility can be put upon the therapist. However, solving the problem in this way creates a new problem. A physiotherapist trained in working with a patient’s body is suddenly required to do highly technical programming, with a misplaced comma being capable of extreme effects. This means that both having the therapist completely uninvolved with the LOPES, and giving complete control, are both problematic for different reasons.

“patient-in-charge” Is perhaps the least problematic mode of use, but also the least useful. This mode of use is useful for healthy subjects, and people who are almost done with training their gait, but is not very useful for someone with heavy problems, since they might as well be walking around freely. Since there is very little that the LOPES does when purely in this mode, responsibility goes to the therapist.

### **Problems and Solutions**

The ethical problem is the need for an easy-to-use exoskeleton that nonetheless keeps the therapist in charge. Giving the therapist “perfect control” means that a therapist goes from a medical professional to a movement-scientist with great knowledge about programming. This ignores the usefulness of having highly sophisticated programming. One of the most useful things are “assist-as-needed” protocols which can assist the patient immediately when it is necessary, but pre-programmed training programs using data from previous users is important as well. Movement scientists can use their knowledge and expertise to create these types of algorithms, while

therapists have very different knowledge. This means that giving the therapist complete control is not always a good idea. A better method is to allow for choices in the programming, with the therapist using knowledge about the patient to decide what kind of pre-programmed interventions are necessary, and being able to control specifics while not making this necessary

Another potentially problematic aspect of “Assist-As-Needed” algorithms is that they are not always predictable in their behaviour, which can take control away from the therapist. This can be solved in two ways. If the assist-as-needed protocols are not used unless the therapist gives explicit consent to this, the therapist is still in charge, but this means that their strongest point, assisting immediately when something goes wrong, is impossible. However, if the exoskeleton informs the therapist and asks for consent after it started the intervention, the problem of responsibility remains if that very first act makes something go wrong. This can be partially solved by making the first, unconfirmed, intervention minimal, but this can bring us back to the earlier problem. A combination of these two techniques might be the programming that delivers the best results. In such a combination, the therapist could be asked to confirm use of the assist-as-needed protocols before they are used, and asked to confirm (and shown the relevant data) after the first time a specific intervention is used, so that the therapist can control which interventions are repeated and which are not.

This ethical analysis of responsibility in the LOPES using a modified SCOT methodology tells us two things. First of all, that the power to influence the design of the LOPES mostly lies with groups that are not directly involved in its use. The design process of the LOPES included the opinions of therapists and other clinicians, but the power to implement their opinions into the LOPES lies with other groups, such as the university or the Roessingh center. Secondly, the field of care ethics indicates that for a good care relationship, the therapist must have influence over what the LOPES is doing in order to be able to take responsibility. Combining these two points leads us to the conclusion that the collaboration of therapists and researchers from the RRD department and involving therapists in an early stage of development was, from the points of view of the care ethics framework used in this article, the right thing to do. While they may not have much power to enforce their meanings into the design of the LOPES, their perspective, and them being able to take responsibility when working with the LOPES is incredibly important from the ethical perspective.

Written and edited by Savvas Kikidis, Niels van der Lugt, Wouter van Dijk and Pieter van den Bosch.

## Ethics and exoskeletons

This magazine has so far tried to explain that the development of technology from idea into a working product to acceptance by society is a complicated process that requires a multitude of approaches in order to attain a well-educated view on these technologies. The question then arises how ethics can contribute to the understanding of technologies in society. In the article on SCOT we have connected moral responsibility to different social groups. This is already an indication of the way ethics could improve existing frameworks. In the following article we will expand this understanding by analyzing exoskeletons and their effect on care givers using two different kinds of practical ethics: care ethics and value ethics.

### The complexity of Ethical Dilemmas

Before we can analyse exoskeletons in care it is important to note that this analysis is not as straightforward as might have been suggested in the introduction to this article. Different ethicists have differing opinions on how and where and to whom ethics can contribute to technology and society. For example, Vallor<sup>37</sup> argues that ethical considerations concerning care robots are mainly written from the point of view of care receivers and that caregivers are left out of the picture in most considerations. And Coeckelbergh argues that we should partly shift our attention from a focus on agency and the 'mind' of a robot towards the ethical significance of the appearance of a robot and what they do to us as social and emotional beings. He furthermore argues that we should not be "*indulging in fantasies about moral robots with robot rights*" but instead think about the way in which robots can contribute to good human life in practice<sup>38</sup>. Coeckelbergh thus opposes the view that we should focus on the morality of robots themselves as proposed by for example Asaro<sup>39</sup>.

Both Coeckelbergh and Vallor show us that an ethical question concerning (care)robots is more complicated than the reader might intuitively expect. Although neither of the two denies the importance of the views they oppose they do show that a full ethical understanding is more complicated than some ethicists might, be it explicitly or implicitly, lead us to believe. Still, to prevent ambivalence, we need to make a choice and pick a framework that allows for a clear ethical view on exoskeletons in care while at the same time teaching us something about robot-human interaction. To this end we use Vallor's framework which gives us insight into the interaction between

<sup>37</sup> Vallor S. (2011) *Carebots and Caregivers: Sustaining the Ethical Ideal of Care in the Twenty-First Century*, *Philosophy and Technology*, 24 (3), pp. 251-268.

<sup>38</sup> Coeckelbergh, M. (2009). *Personal robots, appearance and human good: A methodological reflection on roboethics*. *International Journal of Social Robotics*, 1(3), pp. 217-221

<sup>39</sup> Asaro, P. M. (2006). *What Should We Want From a Robot Ethic?*, *International Review of Information Ethics*, vol. 6.

therapist and exoskeletons by using the two ethical theories mentioned above. By doing so we follow Vallor's goal, which is to show that there are important internal goods for therapists that might be surrendered when using robots in care giving practices.

### Is an exoskeleton a carebot?

Before being able to use Vallor's work we need to show that the carebots Vallor writes about are indeed related to exoskeletons. Vallor defines a carebot as follows: "*robots intended to assist or replace human caregivers in the practice of caring for vulnerable persons such as the elderly, young, sick, or disabled*". Clearly an exoskeleton is, in some aspects, such as intensive therapy, a replacement of care-givers. Exoskeletons are furthermore described by the developers at the university of Twente as being *robotic devices that assist injured people*<sup>40</sup>. This then leads us to the conclusion that we are indeed legitimized in using Vallor's work when analyzing exoskeletons.

### Virtue ethics

The first ethical theory described by Vallor is called virtue ethics. This approach finds its roots in the thoughts of the ancient Greeks and is commonly understood to study the virtues of one's character that allow for human flourishing. These virtues are thought to us through experience and interaction with others. Although different virtue ethicists make use of different taxonomies of virtues, the above guideline is always followed. Vallor distinguishes between a wide array of virtues: patience, understanding, charity, reciprocity, empathy are among others. She however focusses on the latter two to bring across the general point she is trying to make.

### Reciprocity

Reciprocity is fundamental for friendship and human social relations in general. The ethics of reciprocity is sometimes referred to as the 'golden rule' which, generalizing, states the following: *One should treat others as one would like others to treat oneself*. This rule can be found in similar forms in religious texts, philosophical enquiries and lifestyle guidelines from all places and ages. Clearly reciprocity then predicates a symmetrical social relation that involves the giving and taking between two human beings. In care this symmetrical relation can be found in different examples: children fed by parents will at a later age take care of their elderly parents or doctors who visit other doctors when they are sick themselves. Through these relationships we learn to reciprocate and as such will become a part of our moral character. By giving out of hand care giving practices, be it altogether or to an exoskeleton, we could lose the giving and taking between two human beings that is so ingrained in care relations. This could mean that therapist will then not be able to develop reciprocity as

<sup>40</sup> *Laboratory Biomechanical Engineering, Research on LOPES*, retrieved at 20-03-2014 from: <http://www.utwente.nl/ctw/bw/RESEARCH/PROJECTS/LOPES/IND EX.HTML>

a virtue of their moral character. This would not only be a loss of an important internal good for the care giver, it could also be detrimental for the care that is given to a care receiver.

### **Empathy**

Empathy as a virtue must be understood as the capacity to feel with another sentient being, that is: to experience joy and suffering in the same way as another, in the appropriate circumstances and relationships. What is appropriate must be learned through experience and in relation to another human. What then does this mean when an exoskeleton is introduced in the relation between care giver and care receiver? First of all we must note that exoskeletons could prove to be a machine that will allow therapist to, in a way, emotionally let go of their patients. They no longer directly feel what the patient feels as is the case in traditional hands-on methods and instead surrender this important aspect of care to a machine. Vallor underlines this intuition by describing how people often turn away from an emphatic response, fearing the pain and sadness that accompany it. In this light it is understandable how some care givers that lack the virtue of empathy, because they have not yet learned how to act in this way towards their patients, might turn to exoskeletons as an outcome to this fear.

The above explanation shows that that care givers could indeed be at risk of surrendering important internal goods when exoskeletons are introduced in care, namely, two important values that are of fundamental importance in healthy human relationships.

The attentive reader could at this point argue that exoskeletons might actually enable the therapists to empathize or reciprocate more directly with their patients. An exoskeleton could relieve the therapist of unwanted or unpleasant tasks that would otherwise stand between them and their patients. This in turn means that care givers can wholeheartedly give over to care giving and as such develop their moral character in a healthy manner.

### **Care ethics**

Similarly to virtue ethics care ethics looks at the goods internal to practice but differs from the former by focusing on caring practices and -relations. It is in the memories that we have of being cared for and the commitment to the practice of caring for others that we find an ethical ideal. It is this relationship with others, and the commitment to it, that ensures a rich and sustained ethical character.

### **Criteria for care**

Vallor describes how we can identify two different criteria for commitment to a caring relationship: *engrossment and motivational displacement*. Engrossment means having the attitude that allows us to place the interests of others before our own. Needs of the other are placed on the foreground of our

perception while at the same time the importance of our own desires are placed below this. The motivation displacement resulting from this attitude means that we are of the feeling that we must act and do something to help with or relieve the needs and interests of others.

Both these criteria must be seen from a point of view that looks at the practical application of care given by a therapist and received by a patient, which is a face-to-face practice. As such care cannot be given remotely or indirectly. Although transferring care responsibilities to an exoskeleton might show a 'care-for' attitude the actual practice of caring is missing. This means that a therapist that delegates care related tasks to an exoskeletons potentially risks an impoverished or even unsustainable ethical character.

On the other hand we must take note of the fact that caring is a real and practical task. Caring for can only be done within the therapist's physical and emotional capabilities. Trying to extend oneself beyond these borders would be detrimental for the sustainability and wellbeing of one's ethical character. It could thus be argued that the emotional and physical workload, which we wrote about in this magazine in the article 'Social sciences and rehabilitation supported by exoskeletons', placed on contemporary therapist in rehabilitation centers is already an impoverishment compared to the ideal care giving relationship described in this article. An argument could thus be made in favor of exoskeletons in rehabilitation by saying that lessening the (sometimes) unrealistic workload placed on therapists could in fact improve their care giving capabilities by placing them in a more realistic context. Instead of overextending themselves, therapist can now fully focus on their care giving jobs.

A last argument that could be made in favor of exoskeletons in care hinges on the notion that caring is still a choice and a practice that needs to compete with other needs and desires we might have. Surrendering to care might deprive the care giver of the realization of a committed caring relationship. An exoskeleton might be an outcome in this scenario, it would relieve the care giver of unwanted tasks and as such keeping the relationship between care giver and care receiver intact.

We can conclude that even from these two ethical frameworks that we used to examine exoskeletons it is still quite unclear in what way we should approach exoskeletons in rehabilitation. They could on the one hand be detrimental to the development of a care givers moral character and care giving capabilities but on the other hand relieve us of certain task that might in fact enable us to improve these two factors. Despite this the importance of an ethical study of exoskeletons in rehabilitation also becomes clear: realizing that the overall development and the subsequent implementation of exoskeletons is more complicated than just making and using it is of fundamental

importance and will allow us to become more conscious of our technological developments and the relationships we form with others in general and more specifically in a rehabilitation environment.

Written by Niels van der Vlugt

Background reading:

Noddings, N. (1984). *Caring: A feminine approach to ethics and moral education*. Berkeley: University of California Press.

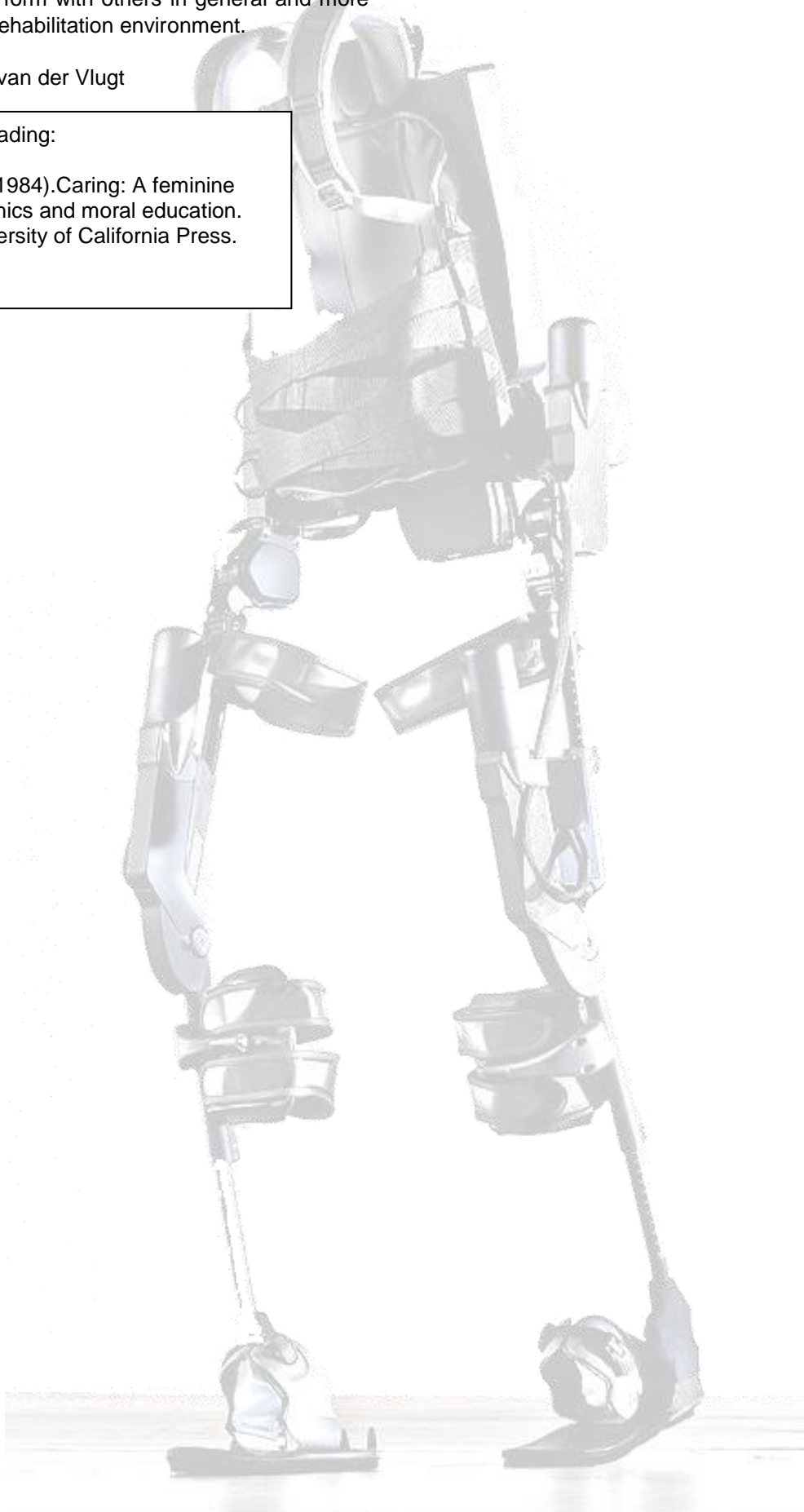

## Comparing the design process of the LOPES with the ethics design proposed by Aimee van Wynsberghe

### Taking ethics into account

Technology factors and social factors contribute to the design of the exoskeletons as was mentioned in previous articles. However, in the design process choices have to be made regarding the scope of a project to fill gaps between end-users, designers and therapists. The design involves a mediated process in which requirements will have to come together from those stakeholders. In practice problems arise due to vague requirements and specifications that have not been mentioned or made clear. Ethics or more specifically ethics within a design methodology allows for guiding the design process and steering the development. In this chapter we will combine all knowledge mentioned in the previous chapters into a framework to connect the dots in our magazine.

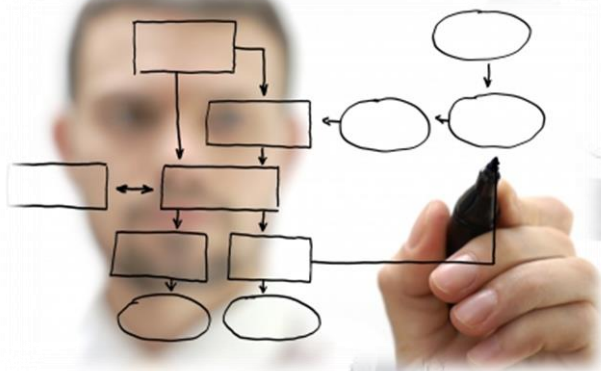

Figure 15 connecting the dots in design

**Step 1: A more unified framework to guide design.**  
A more unified framework in which care factors are described to build a good robot is proposed by A. van Wynsberghe.

The care centered framework aims to outline the orientation from which one begins in order to develop an ethic of the relationship between care robot and the other actors involved in the care practice.

Her Care-Centered Framework which includes values allows important components to be described and put together as a specification tool to focus on design productivity and therefore speed up or aid the design. This so called CCVSD (care centered value sensitive design) methodology is especially meant to provide a guideline for analysis of a practice with and without the use of a care robot.

Using the methodology to compare two care robots used for the same practice with different capabilities, allows anyone to envision the resulting care practice in terms of the robot's impact on care values as well as the robot's potential impact on care in the holistic

sense. The components are explained below.



- **Context component**<sup>41</sup>.

Crucial is to know where and in which context the robot will be used. For example will the robot be used in a hospital or a ward? By specifying context in terms of a nursing ward versus a home setting is of importance given that the prioritization of values differs. Specific upfront requirements about the setting and the context allows for minimal misunderstandings. Moreover, specifying the context plays a crucial role for understanding the prioritization of values. It is a helpful in development to shape the character of the development and suggests probably necessary components

- **Practice component**<sup>42</sup>

A care practice envisions a care task or a series of tasks in which one can grasp the fortitude of each action and interaction between a care-giver and a care-receiver.



The practice for which the care robot will be used plays a dominant role in the prioritization as well as the interpretation of values/moral elements.

Each of the practices requires the elements of attentiveness, responsibility, competence and reciprocity<sup>40</sup>; however, they mean very different things depending on the type of practice. It must therefore be acknowledged that understanding that care tasks are more than just 'tasks' but are rich practices in a value-laden environment that act to bring and about the promotion of values. This may be one of the most crucial points for designers to grasp.

- **Actors involved**

The care practice that a robot will enter involves a network of human (and nonhuman) actors<sup>43</sup> in relationship. The robot therefore has the ability to shift the roles and responsibilities distributed within these relationships. The robot may be delegated a certain portion of the role of the care-receiver. It is important to remember that the human actors are not acting alone in order to manifest values. They work together with each other but also with technologies already in use in the healthcare system. Therefore technologies have often been considered extensions of the nurse's body



<sup>41</sup> A van Wynsberghe (2011), *Designing Robots for Care: Care Centered Value-Sensitive Design, Science and Engineering Ethics*, 19 (2), pp.15

<sup>42</sup> A van Wynsberghe (2011), *Designing Robots for Care: Care Centered Value-Sensitive Design, Science and Engineering Ethics*, 19 (2), pp.15-16

<sup>43</sup> A van Wynsberghe (2011), *Designing Robots for Care: Care Centered Value-Sensitive Design, Science and Engineering Ethics*, 19 (2), pp.16.

Image sources:  
[http://slimmersamenwerken.files.wordpress.com/2011/04/clip\\_image001\\_thumb.png?w=397&h=280](http://slimmersamenwerken.files.wordpress.com/2011/04/clip_image001_thumb.png?w=397&h=280)

or self and technologies mediate all of the moral elements of the framework.

- **Type of Robot<sup>44</sup>**

The robot type describes the domain in which the robot will be used. This classification of robots is dependent on the amount of human interaction the robot will have and the predictability or structuring of the environment within which the robot is working<sup>41</sup>.



- **Manifestation of moral elements<sup>45</sup>**

The manifestation of moral elements takes into account how the values are observed, prioritized and interpreted in a care practice in a given context. This can be with or without the given robot. Special elements mentioned are attentiveness, responsibility (explained in our magazine), competence, and reciprocity<sup>46</sup>. These elements can be considered the basic requirement of any practice and independent of individual care givers, receiver's context or practice. The moral elements act as a heuristic tool to ensure the incorporation and the necessary reflection of the fundamental care values in the design of a care robot.

In the last chapter we suggest to make a business case of the exoskeleton using the framework and the outcome of all interviews.

Now that we have addressed several problems in design in the first part of our magazine we will compare the design process in a practical way with the CCVSD framework<sup>41</sup>.

## Business Case: Care Robot Exoskeleton

### What's in it for me? What have we learned until now?

We may ask the question at the end of the magazine: **what kind of care do we want to provide and in so doing how may it steer the design and development of care robots?** Using the framework provided above allows for any with or without technical knowledge or the presence of a care robot to analyze the components of good care practice to envision the

resulting care practise in terms of the robot impact on care values and the potential impact on care in a holistic sense. A good design starts (according to van Wynsberghe) with identifying the context practices actors involved and how moral elements are manifest in traditional care practices. She proposed that the framework can be used both in retrospective and in prospective ethical assessment. It may be used at multiple times throughout the design process of a care robot. This raises an interesting question whether the development of LOPES could be more successful when using this framework. We will now look at design again in combination with her framework and the elements mentioned in order to question whether it can speed up development by looking at the development practices.

### Reflections on guiding development.

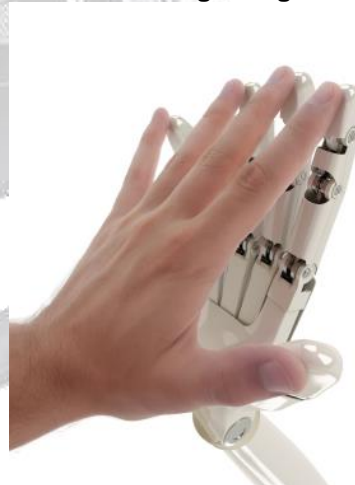

Figure 16 Integration care ethics & technology

We look at the previous schematically summary of the development of LOPES in previous figure 8. According to us, van Wynsberghe's model would fit throughout the full development. The CCVSD allows zooming in, like a microscope into the requirements and creates a bridge between designers and important actors involved.

These requirements can be acquired throughout the full development, but there are particular cases in which some elements may be easier to specify.

<sup>44</sup> A van Wynsberghe (2011), *Designing Robots for Care: Care Centered Value-Sensitive Design*, *Science and Engineering Ethics*, 19 (2), pp.16-17

<sup>45</sup> A van Wynsberghe (2011), *Designing Robots for Care: Care Centered Value-Sensitive Design*, *Science and Engineering Ethics*, 19 (2), pp.21-22

Image sources: <http://www.prosoftgroup.com/wp-content/uploads/2013/07/technology.jpg>

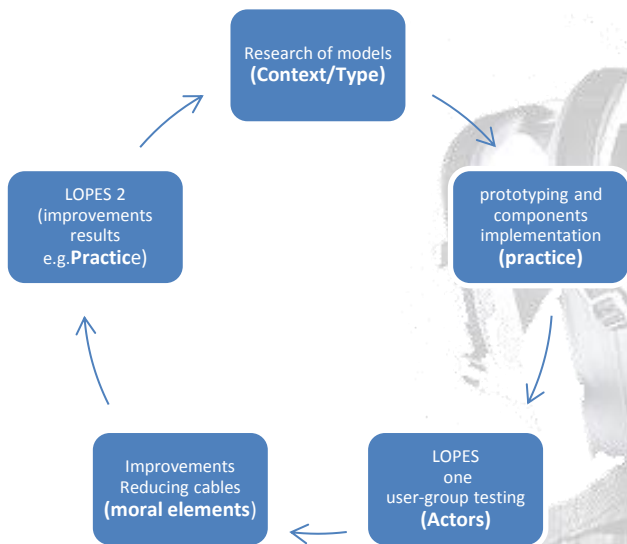

Figure 17 A schematic overview of development having the elements of CCVSD integrated

### Context

We can integrate the elements within our first model. The e.g. context component can be immediately taken into account in the phase of the research of models (see figure 17). By taking the context into account into an early stage this allows the developers to see the domain more clearly. When Prof. Herman van der Kooij started his research he would for example have been thinking in which domain his robot would be used. (And how the models he designed could fit the parameters of the design). The specification of specific requirements within the engineering context leaves out questions of how the robot would be designed and which knowledge and language is used to leave out possible assumptions. (E.g. How to robot will be used and in What field.) This specification often requires the practice of writing down the expectations of for example the usage of the product by its customers to guide development.

### Practice and type of robot

Until now only active patients receive treatment with LOPES. This means that elderly people and people with severe disabilities cannot receive treatment but this does not have to be the case in the future. The practice component determines the usage of the Robot and in the future. The designers can take into account that Exoskeletons cannot be as functional as the wheelchair, or other means of assistance, for everyday life purposes.

However, by looking at the required practice (and of that in the future) the awareness of the possibilities in new opportunities becomes a significant guidance of future improvements throughout the development process for example during prototyping. In the prototyping phase specific components can be implemented to fulfill certain subtasks of practice (e.g. carrying people). Additional, a main task would be to develop practices such as supporting the patient while walking. More will be explained on the next page about incorporation the practice component in prototyping.

### Actors involved

In the part “the social context of the LOPES” it will become clear that Roessingh R&D Center and The University of Twente played a significant role in the development, namely by the actors involved University, therapist and R&D that steered development. They form an important user group because feedback can be acquired throughout the development. Below is a chart of how feedback could be used in the different phases. All actors contribute to the phases of the development and mediate each other. Below is chart of how development can be seen. We see the phases Requirements, Design, Implementation, Verification and Maintenance which are all common words in development terminology. In these stages the actors will contribute and also in the sense of specifying other elements of CCVD.

What you may notice is that this overview is not that flexible, all processes within a stage have to wait for each other in below model to go to the next stage. This is also called “waterfall” because of its sequential design process<sup>47</sup>. See the below figure 18.

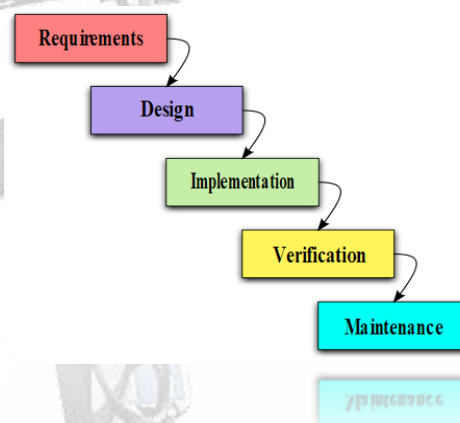

Figure 18 waterfall development

### The process of development revised

The figure 19 illustrates thus raises questions whether the framework does not provide a more flexible methodology and a better eco-system of development.



Figure 19 introductions to agile

<sup>47</sup> Waterfall model. (n.d.). Retrieved at April 5, 2014, from [https://www.princeton.edu/~achaney/tmve/wiki100k/docs/Waterfall\\_model.html](https://www.princeton.edu/~achaney/tmve/wiki100k/docs/Waterfall_model.html)

## Flexible development & Conclusion

The framework proposed by van Wynsberge proposes (moral) elements being implemented within the development. It can be used as a retrospective and prospective tool for implementing ethics within a care robot. This business case allowed for a practical implementation of the framework. The determination and verification of these elements throughout the whole development can be distributed in testing (using the elements within iteration cycles of development), resulting that the development becomes more flexible in comparison with the previous development methodology. It allowed only one occasion of varying results. Below you can find how such a testing can take place which proposes an agile way of development<sup>48</sup> and in figure during all stages.

This is often used in software development but for the purpose of our paper it will illustrate how a scope of CCVSD can be integrated within any development because of the Requirements, Design, Implementation, Verification and Maintenance disciplines by developers during a development cycle. Agile development is an important trend in the engineering discipline.

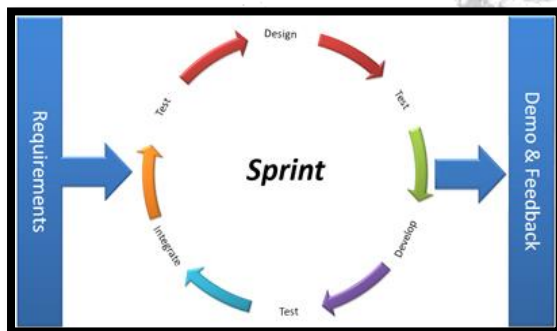

Figure 20 Elements taken into account throughout development<sup>49</sup>

The main advantage in Agile development is its backward scalability by verification of these proposed elements. Under a waterfall approach it is not easy to change the decisions and implementations that were made in previous stages. If we want to make changes under waterfall we will have to build the entire project from the scratch once again. Now in the development process all elements are checked and integrated in testing from design, develop and the testing context

<sup>48</sup> What Is Agile Methodology? Retrieved at April 5, 2014, from: [agilemethodology.org](http://agilemethodology.org)

Image sources:

[http://rossgkinney.com/wp-content/uploads/2013/07/Waterfall\\_model\\_1.svg\\_.png](http://rossgkinney.com/wp-content/uploads/2013/07/Waterfall_model_1.svg_.png)

<http://www.intranetconnections.com/wp-content/uploads/2013/02/Agile-Development-Intranet-Software.png>

<http://www.dgc.co.uk/wp-content/uploads/2012/11/agile-sprint.jpg>

Image source:

<http://www.dgc.co.uk/wp-content/uploads/2012/11/agile-sprint.jpg>

<http://wildmeadowsfarm.com/wp-content/uploads/2010/10/PcEthics1.png>

<http://wildmeadowsfarm.com/wp-content/uploads/2010/10/PcEthics1.png>

(e.g. testing with a therapist) when building a component.

Moreover, the flexibility to error check under any part of the development stage makes Agile closing gaps between actors. (This will result in less problems at the end of the development of a Robot project which requires to have ethics incorporated) Last but not least, since Agile provides flexibility to make changes as per customer requirements it is more inclined towards better client satisfaction. This is a real set back for the Waterfall model and without the CCVSD tool.

By implementing the mentioned elements in a flexible way it is easier to build a good caring robot.

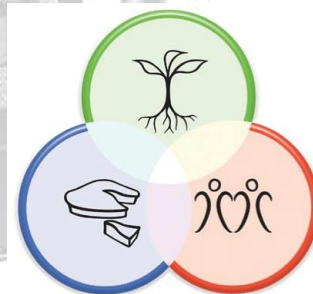

Figure 21 Moral Elements integrated within development

## Interview with Aimee van Wynsberghe

Interview was held on 5<sup>th</sup> of March 2014 at Ringhorst

Written by Pieter van den Bosch



## Safety and Exoskeletons.

In the following article we shall investigate standards for safety when designing rehabilitation robots. We shall furthermore explain the mechanics of analyzing safety from a social science perspective and how this research of safety is done.

### Introduction to the Safety Problem.

As far as it has to do with robots there is a general framework in the strategies for safety, according to which “robots should be isolated from humans and they have to be turned off when they cannot be isolated”<sup>50</sup>. It is more than obvious that this approach is quite problematic in the field of rehabilitation robots. The rehabilitation robots have to interact with humans/patients in order to produce the expected result, which is the improvement of the rehabilitation process, both for the patients but also for the clinicians. Due to the aforementioned reasons the need for a safety framework for rehabilitation robots is more pressing than ever.

The International Organization of Standardization, also known as ISO, has as its main subject to “develop and publish International Standards”<sup>51</sup>, so it goes without saying that the aforementioned organization is the most specialized organization for the development of Safety Standards as long as it has to do with Rehabilitation Robots. Even though ISO has set “the standards for the safety of standard machinery, in which industrial robots are included”<sup>46</sup>, it is the common ground that rehabilitation robots cannot and should not be included in this content. As a result, different organization and institutions tried to fill that gap. The examination of these incentives goes beyond the present article; however there are certain concepts that are common ground.

### Basic Concepts. What is Safety and how can this term be conceptualized?

According to Nokota and Tejima, the ISO had introduced “the basic concepts for the safety of the machinery in ISO/IEC Guide 51:1999”<sup>52</sup>. Even though the aforementioned standard has been revised in 2014 by the ISO/IEC Guide 51:2014<sup>53</sup>, there was not a fundamental change in the basic concepts that we are going to mention.

These concepts are the following<sup>46</sup>:

<sup>50</sup> Nokota, M. and Tejima N. (2004), *A Safety Strategy for Rehabilitation Robots, Advances in Rehabilitation Robotics*, pp. 177-185, Springer Publications.

<sup>51</sup> International Organization of Standardization, retrieved at 11-04-2014 from: <http://www.iso.org/iso/home.htm>

<sup>52</sup> ISO/IEC Guide 51:1999, *Safety aspects, Guidelines for their inclusion in standards*.

<sup>53</sup> International Organization for Standardization, retrieved at 11-04-2014 from: [http://www.iso.org/iso/home/store/catalogue\\_tc/catalogue\\_detail.htm?csnumber=32893](http://www.iso.org/iso/home/store/catalogue_tc/catalogue_detail.htm?csnumber=32893)

- Safety is defined as freedom from unacceptable risk
- Risk is defined as combination of the probability of occurrence of harm and the severity of that harm.
- Tolerable risk is defined as the risk which is accepted in a given context based on the current values of society.”

These definitions provide the guidance for a Safety Strategy. What is obvious here is that a Safety Strategy, due to these definitions upon which it is based, is a demanding procedure. Such a procedure comes close to the domain of ethics, since it takes into account values of a given society. In that way, in the Exoskeletons’ example, we have to answer the question that has to do with the tolerable risk that we can accept in order to approach the term of safety.

### How ISO standards work in the design of a Rehabilitation Robot.

There is the acceptance of five measures for safety. The four of these measures should be materialized in the process of design. The fifth measure has to do with the information of the end user about the safety of the machinery, in our case of the Exoskeletons, which he/she is going to use. The five measures, as defined by the ISO 12100 – 1:1992 (ISO 1992)<sup>54</sup>, are the following :

1. Specify the limits of the machine.
2. Identify the hazards and assess the risks.
3. Remove the hazards or limit the risks as much as possible.
4. Design guards and/or safety devices against any remaining risks.
5. Inform and warn the user about any residual risks.

As it is obvious in Fig. 22 the four measures constitute a continuous cycle in the part of design. If the result of these steps is sufficient, which means that the risk in the use of the end product is lower than what is interpreted as tolerable risk, then the product can come out in the market and the only presupposition that remains is the awareness of the user about the risks that he/she is going through while he/she is using the robot; if the remaining risk is higher than the tolerable one then the safety measures have to be repeated.

As it becomes obvious safety is an issue that has to do both with the design of the Exoskeleton and the cost that is permissible for this technological artifact. In that way, a “state-of-the-art” technology has to be safe but also its cost has to be a minimum as possible. An Exoskeleton that is unsafe is of no use, just like an

<sup>54</sup> ISO/TR 12100 – 1:1992, *Safety of machinery, Basic Concepts, General Principles for Design, Part 1: Basic terminology, methodology*.

Exoskeleton that is tremendously expensive. And these different aspects have to be integrated in the end product; making its design an even more complex procedure.

### Example CASE Risk reduction in the technology.

One of the risks in exoskeletons is that the exoskeleton tries to enforce a movement that the body does not agree with. For example, the “knee” of the exoskeleton could try to bend forward, in a way that the human knee does not agree with. If the exoskeleton tries to enforce this unnatural movement, then damage to the patient inside the exoskeleton can occur. In the design of the LOPES, this risk factor has been reduced by technological means. Since the movements of the LOPES mimic that of the skeleton of the patient, the designers implemented mechanical safety limits to motion and torque in the LOPES<sup>55</sup>.

individuals. This involves quantitative and qualitative techniques.

### Operationalisation

The first step is to identify the variables that we want to measure. These variables can be precise and well defined, for example age and monthly income; while others can be “abstract, for example self-esteem and belief, but also some can be only deducted/observed indirectly, such as memory and motivation”<sup>56</sup>. As already mentioned the variables that we want to investigate are safety, risk and tolerable risk. As it is obvious these variables are quite abstract.

As a result there can be different ways to measure safety, risk and tolerable risk. One possible methodology is presented by Nokata and Tejima. In that way the risk that arises from the use of a technological artifact can be calculated by the following equation:

$$R = Q \times F \times C \times N$$

The different variables of the above equation are the following<sup>57</sup>:

- R: risk related to the considered hazard
- Q: probability of occurrence of harm
- F: frequency and duration of exposure
- C: severity of possible harm that can result from considered hazard
- N: number of exposure people

In order to qualify the above variables social science has to follow a research strategy. This research strategy must include “the definition of the population of interest, the definition of variables, their status and relationships to one another”<sup>58</sup>. This is left out of this article as the aim of this article is to provide a general description of safety within social science.

*Written by Savvas Kikidis, edited by Pieter van den Bosch*

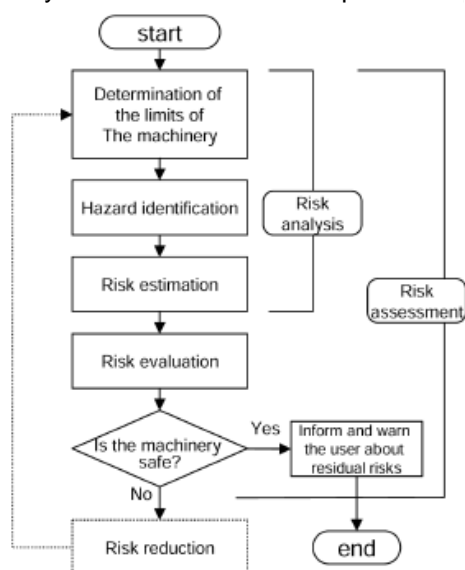

Figure 22 Risk assessment and risk reduction of safety measures in design (ISO 14121:1999, ISO 12100-1-2)

### Social Sciences research methods and the case of safety.

The next step in our analysis is to turn all the aforementioned variables into numbers that can be used for the evaluation of a certain technological artifact in terms of safety. The methodology that we are going to use for this purpose comes from the Social Sciences. Social science is an academic discipline concerned with society and the relationships among individuals within a society. It includes anthropology, economics, political science, psychology and sociology. In a wider sense, it may often include some fields in the humanities studies such as archaeology, history, law, and linguistics. Within the research practice of social sciences, variables are analysis to draw conclusions on relationships for

<sup>55</sup> Veneman, J. F., Kruidhof, R., Hekman, E. E., Ekkelenkamp, R., Van Asseldonk, E. H., & van der Kooij, H. (2007). Design and evaluation of the LOPES exoskeleton robot for interactive gait rehabilitation. *IEEE Transactions on Neural Systems and Rehabilitation Engineering*, 15(3), pp. 379-386.

<sup>56</sup> Hunka, Ag. (2013) *Social Science Research Methods, Presentation in TechnoLab class.*

<sup>57</sup> Nokata, M. and Tejima N. (2004), *A Safety Strategy for Rehabilitation Robots, Advances in Rehabilitation Robotics*, pp. 177-185, Springer Publications.

<sup>58</sup> World Health Organization (2001) *Health Research Methodology: A Guide for Training in Research Methods*, World Health Organization, Regional Office for the Western Pacific, Manila.

## Some Paradoxes of Exoskeletons.

### Introduction

The introduction of care robots in the domain of Care is still in its early phase. Nevertheless, a plethora of reasons manifested through “demographic, economic, cultural and institutional pressures”<sup>59</sup> make it clear that this domain will expand in the near future. The aforementioned reasons strive from the new needs of society and the pressure imposed by these new needs to the social institutions. However, we must not forget the whole picture; which means that even though society has the power to shape the technological development, technology has also the power to shape society’s needs.

“The exponential growth in the power of silicon chips, digital sensors and high-bandwidth communication improves robots just as it improves all sorts of other products”<sup>60</sup>. This means that the technological development of our times will be another factor of crucial importance for the introduction of care robots in the domain of Care, since care robots will be cheaper and more efficient in the future. Due to the above reasons we can conclude that care robots will turn out to be a reality in the years to come, in that way the philosophical and ethical evaluation and examination of such novel technologies is a task of crucial importance.

As a point of departure for our analysis we can use the conclusion that “surrendering caring practices to robots might be risky or ethically worrisome, but so is maintaining the status quo”<sup>55</sup>. What is obvious here is that we have to exploit our technological capabilities in order to alleviate the burden upon the shoulders of the care receivers and the care givers and not stick to a static approach.

The main purpose of this article is to draw a parallelization between some of our conclusions and Andrew Feenberg’s influential article “Ten Paradoxes of Technology”<sup>61</sup>. By following that pattern we aim to unfold some aspects of the examined technology, namely Exoskeletons, and what these aspects have to say about this technology.

<sup>59</sup> Vallor S. (2011) *Carebots and Caregivers: Sustaining the Ethical Ideal of Care in the Twenty-First Century*, *Philosophy of Technology*, 24, pp. 251-268.

<sup>60</sup> *Economist* (2014), *The rise of robots*, Available Online: [www.economist.com/news/leaders/21599762-prepare-robot-invasion-it-will-change-way-people-think-about-technology-rise?zid=291&ah=906e69ad01d2ee51960100b7fa502595](http://www.economist.com/news/leaders/21599762-prepare-robot-invasion-it-will-change-way-people-think-about-technology-rise?zid=291&ah=906e69ad01d2ee51960100b7fa502595)

<sup>61</sup> Feenberg A. (2009) “Ten Paradoxes of Technology”, 2009 Biennial Meeting of the Society for Philosophy and Technology, 2009 Biennial Meeting of Society and Philosophy.

### 1. The paradox of the parts and the whole.

The technology of Exoskeletons is based upon different components and we should not underestimate the role of this fact. In the chapter under the title “Technical Description of the LOPES” we described the most important parts of LOPES.

We should always keep in mind that “the parts find their origin in the whole to which they belong”. This can complicate the image that we have for the Exoskeletons. Since a development in one of its parts can produce a tremendously good result in their function, while some other parts, no matter how innovative and technologically sophisticated they are, cannot have a big effect in the technology of Exoskeletons.

Another remark of great importance is that the Exoskeletons are not only based upon their different parts, but also upon the Control Modes in which they operate. As it was already emphasized this aspect of LOPES plays a crucial role in its innovative character.

### 2. The paradox of the obvious.

This paradox, as stated by Feenberg, refers to the cases in which the “obvious withdraws from our view”. In the first phases of the introduction of Exoskeletons in the Rehabilitation process their impact upon this process and the possible changes that this introduction may carry remain obvious. The challenging task is to examine a future case, when clinicians and physiotherapist are working with Exoskeletons from the first moment of their career<sup>62</sup>. Then, when this new technology is the main form of treatment, maybe the notion of Care will not play the fundamentally crucial role that it plays now. This conclusion emphasizes the need of an Ethical evaluation and examination of Exoskeletons in this early phase.

### 3. The Paradox of the origin.

Every technological artifact has to pass through a certain process of evolution. We can connect this paradox with the “Paradox of the parts and the whole” and conclude that the parts have to reach a point of technological development in order to be sufficient for the creation of an Exoskeleton. After that, the connection of these different parts has to be based upon concrete scientific and technological grounds, in order to move forward to the design of an Exoskeleton. By using “the paradox of the origin” we can make a step further and add that safety issues have to be emphasized as a factor of special importance. An accident in the field of rehabilitation can turn out to be very influential in the development of Exoskeletons. Since an accident or a malfunction can turn the patients against this technology in this early face of its introduction, safety issues can play a vital role for the

<sup>62</sup> P. van Bosch and S. Kikidis, *Interview with Aimee van Wynsberghe*  
*Interview was held on 5<sup>th</sup> of March 2014.*

development of the examined technology and they have to be examined in depth.

#### 4. The paradox of the frame

This paradox is formulated as follows, “efficiency does not explain success, success explains efficiency”. This quote was mentioned again in our magazine, but now that we covered all the different aspects of the technology of Exoskeletons, the aforementioned quote seems more meaningful than ever. We quote from Feenberg’s text: “There is no general rule under which paths of development can be explained. In each case only a study of contingent circumstances of success and failure tells the true story”.

In that way, if Exoskeletons are successfully introduced in the Rehabilitation process, then we can conclude that as a technology it proved to be sufficient in all the different aspects.

But what will be the case if Exoskeletons fail? The answer to this question is not an easy one. Since technical, social, economical reasons or even more political circumstances and cultural values can be blamed for this failure.

#### 5. The democratic paradox

Previous in our magazine we tried to identify and examine the different groups that are deployed around the technology of Exoskeletons. As we mentioned we adopted the framework of the SCOT approach, which supports that the social conditions shape and transform the technology. But we also mentioned that this is not the whole picture. Here we have the chance to make of more in-depth examination. In his text, Feenberg identifies the democratic paradox as follows: “The public is constituted by the technologies that bind it together but in turn it transforms the technologies that constitute it”.

Just like the different groups took part in the shaping of Exoskeletons, the introduction of Exoskeletons in the Rehabilitation process will transform the identity and interests of these groups. In that way that we identify as Rehabilitation Process and what we identify as the Technology of Exoskeletons cannot and should not be regarded as two independent factors. On the contrary, there is a strong connection between those two and we can describe this connection as the same one between two communicating vessels. A change in one of them cannot be restrained in its limits but it is conveyed to the other vessel as well.

This paradox can be said to fully apply in our case. To begin with, one of the advantages of LOPES is that it was the aftermath of the cooperation between the technicians, from the University of Twente, and the clinicians, from Roessingh. In that way a highly innovative product was created, this was based upon the demands and the needs of the clinicians and their patients. In that way, using Feenberg quote, “the public

transformed the technology that constitute it”. But we should not forget that “the public is also constituted by the technologies that bind it together”. In our case this means that the social groups around the Exoskeletons may change due to the introduction of this Technology in the rehabilitation process. The clinicians and physiotherapists can turn out to be the most vulnerable group. Since, if the Exoskeletons prove to be successful as a technology, they will have to adopt in the changes that such a change may carry. This can happen if the clinicians and physiotherapists receive a different education than they do know and they must know how to operate a technical artifact like Exoskeletons. But such a result can diminish their role as we now know it, but also change the values of the rehabilitation process.

*Written by Savvas Kikidis*

#### Conclusion

*In this magazine we tried to grasp the technology of Exoskeletons and draw the pattern of what would be a successful way to introduce such a technology in the Rehabilitation process. We examined the technical part of this technology, the environment of social institutions in which it is going to be introduced and the possible ethical problems that it is going to create. What is far from obvious is that the development of technology is not a one dimensional process. We have to examine a plethora of different factors. What this article tried to add is that these factors are not even stable, but they change both in temporal and spatial terms. Thus a successful pattern for the introduction of Exoskeletons now, can turn to be a failure in the future if it remains static. But also it cannot serve as guidance for the introduction of Exoskeletons in a country that shares and embraces different values.*

*Sincerely,  
The editors.*

#### Did you know?

Andrew Feenberg is Canada Research Chair in Philosophy of Technology in the School of Communication, Simon Fraser University, where he directs the [Applied Communication and Technology Lab](http://www.sfu.ca/~andrewf/index.html). He studied philosophy under [Herbert Marcuse](http://en.wikipedia.org/wiki/Herbert_Marcuse) at the University of California San Diego and was awarded his PhD in 1972. Feenberg’s primary contribution to the philosophy of technology is his argument for the democratic transformation of technology.

#### References:

<http://www.sfu.ca/~andrewf/index.html>

[http://en.wikipedia.org/wiki/Andrew\\_Feenberg](http://en.wikipedia.org/wiki/Andrew_Feenberg)





## In vitro meat

Karin van Leersum  
Joris Luyt  
Wouter Versluijs  
Dimitrios Vlachos

## TwentePAM

Ryanne de Boer  
Ruud van Laar  
Peter Binipom Mpuan

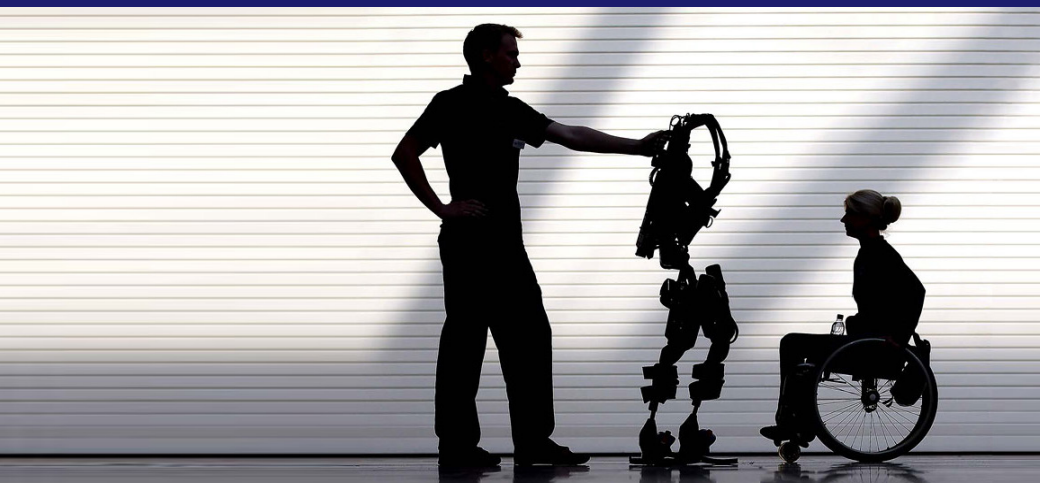
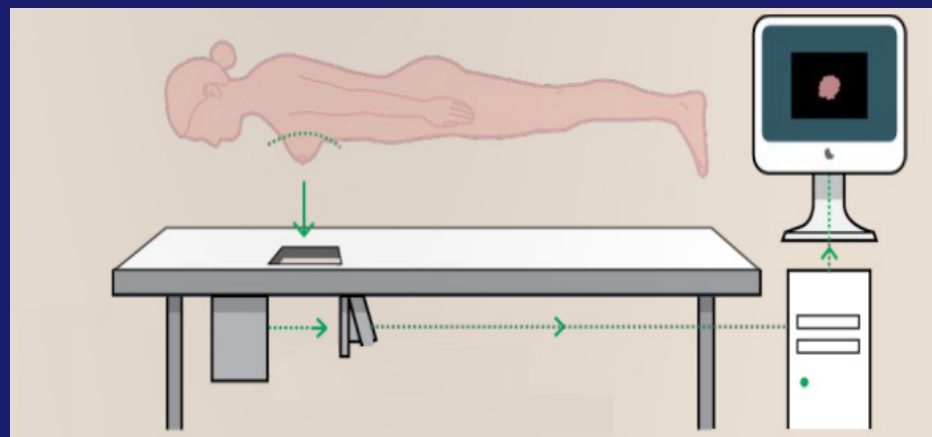

## Exoskeletons

Wouter van Dijk  
Pieter van den Bosch  
Savvas Kikidis  
Niels van der Vlugt