

University of Groningen

Individual Heterogeneity in the Relations Between Sleep, Inflammation, and Somatic Symptoms

Jonker, Iris; Visschedijk, Sjoerd; Rosmalen, Judith G M; Schenk, Hendrika Maria; Van Ockenburg, Sonja L

Published in:
 Psychosomatic Medicine

DOI:
[10.1097/PSY.0000000000001175](https://doi.org/10.1097/PSY.0000000000001175)

IMPORTANT NOTE: You are advised to consult the publisher's version (publisher's PDF) if you wish to cite from it. Please check the document version below.

Document Version
 Publisher's PDF, also known as Version of record

Publication date:
 2023

[Link to publication in University of Groningen/UMCG research database](#)

Citation for published version (APA):

Jonker, I., Visschedijk, S., Rosmalen, J. G. M., Schenk, H. M., & Van Ockenburg, S. L. (2023). Individual Heterogeneity in the Relations Between Sleep, Inflammation, and Somatic Symptoms. *Psychosomatic Medicine*, 85(3), 266-272. <https://doi.org/10.1097/PSY.0000000000001175>

Copyright

Other than for strictly personal use, it is not permitted to download or to forward/distribute the text or part of it without the consent of the author(s) and/or copyright holder(s), unless the work is under an open content license (like Creative Commons).

The publication may also be distributed here under the terms of Article 25fa of the Dutch Copyright Act, indicated by the "Taverne" license. More information can be found on the University of Groningen website: <https://www.rug.nl/library/open-access/self-archiving-pure/taverne-amendment>.

Take-down policy

If you believe that this document breaches copyright please contact us providing details, and we will remove access to the work immediately and investigate your claim.

Downloaded from the University of Groningen/UMCG research database (Pure): <http://www.rug.nl/research/portal>. For technical reasons the number of authors shown on this cover page is limited to 10 maximum.

OPEN

Individual Heterogeneity in the Relations Between Sleep, Inflammation, and Somatic Symptoms

Iris Jonker, MD, PhD, Sjoerd Visschedijk, Msc, Judith G.M. Rosmalen, PhD, Hendrika Maria Schenk, MD, PhD, and Sonja L. Van Ockenburg, MD, PhD

ABSTRACT

Objective: Poor sleep is associated with the experience of more somatic symptoms and a proinflammatory state, whereas a proinflammatory state may also result in the experience of more somatic symptoms. However, existing studies ignore individual differences in these associations. We aimed to study relations between sleep, inflammatory markers, and somatic symptoms at a within-individual level.

Methods: Time series of daily data on sleep, somatic symptoms, and inflammation markers in 10 healthy individuals (age, 19–58 years; three men) for 63 days were analyzed. Bidirectional lagged ($t - 1$) and contemporaneous (t) relations between sleep duration, inflammatory markers (C-reactive protein, interferon- α , interleukin 1RA), and somatic symptoms were analyzed using 24-hour urine and diary data. Unified structural equation modeling was used to analyze the association between sleep duration, the three inflammatory markers, and the amount of somatic symptoms at the individual level.

Results: Associations were found between sleep and at least one of three inflammatory markers in four individuals, both positive (three associations) and negative (five associations) and contemporaneous (four associations) and lagged (four associations). Sleep was related to somatic symptoms in four individuals, both positive ($n = 2$) and negative ($n = 2$) and contemporaneous ($n = 3$) and lagged ($n = 1$). Inflammatory markers were associated with somatic symptoms in three individuals, both positive (three associations) and negative (one association) and contemporaneous (three associations) and lagged (one associations). Two individuals showed no associations between sleep, inflammatory markers, and somatic symptoms.

Conclusions: We observed a large variability in presence, strength, and direction of associations between sleep, inflammatory markers, and somatic symptoms.

Key words: somatic symptoms, sleep, inflammation, immune activation, $n = 1$, diary, day-to-day sampling design, unified structural equation modeling, time series analysis.

INTRODUCTION

Poor sleep and sleep deprivation are linked to the experience of somatic symptoms, with or without a clear underlying pathology (1–3). Results from previous studies trying to explore the pathophysiological pathways between sleep disturbances and morbidity and mortality point toward a role for the immune system (4,5).

In the last decade, group-level evidence has been found for an association between poor sleep and various inflammatory markers (6–11). These inflammatory markers are also associated with somatic symptoms (7,12–16). One cross-sectional study focused on sleep, low back pain, and inflammation and found an association between insomnia and chronic low back pain. C-reactive protein (CRP) was found to be associated with low back pain and with insomnia in the group with normal CRP levels (<3 mg/L), but not in the group with “elevated” or “very high” levels (17).

Three important limitations exist in the current literature on sleep, inflammation, and somatic symptoms. First, most studies are cross-sectional and rely on a single assessment of inflammatory

markers (6). However, inflammatory marker concentrations can vary greatly during the day, with an influence of circadian rhythms on inflammatory markers (18). This makes it difficult to find and interpret associations between sleep, somatic symptoms, and single measurements of inflammatory markers. Second, although multidirectional relationships between sleep, inflammation, and somatic symptoms are hypothesized, only one cross-sectional study included all three variables in one model, focusing on low back pain (17). Third, the intertwined associations between sleep, inflammation, and somatic symptoms on an individual level are still unknown. These associations could vary greatly between individuals.

Studying individuals over time using a *day-to-day sampling design* might provide absolution for these limitations. It is important to use noninvasive techniques when collecting inflammatory

CRP = C-reactive protein, IFN- α = interferon α , IL-1RA = interleukin 1 receptor antagonist, PHQ-15 = Patient Health Questionnaire-15, SS-score = somatic symptoms score, uSEM = unified structural equation modeling

From the Departments of Psychiatry, Interdisciplinary Center for Psychopathology and Emotion regulation (ICPE) (Jonker, Visschedijk, Rosmalen, Van Ockenburg), and Department of Internal Medicine (Rosmalen, Schenk, Van Ockenburg), University Medical Center Groningen, University of Groningen, Groningen, the Netherlands, Groningen, the Netherlands.

Address correspondence to Iris Jonker, MD, UMCG, Department of Psychiatry, Postbus 30.001, 9700 RB Groningen, the Netherlands. E-mail: ijonker01@umcg.nl
Received for publication June 15, 2022; revision received December 21, 2022.

DOI: 10.1097/PSY.0000000000001175

Copyright © 2023 The Author(s). Published by Wolters Kluwer Health, Inc. on behalf of the American Psychosomatic Society. This is an open-access article distributed under the terms of the Creative Commons Attribution-Non Commercial-No Derivatives License 4.0 (CCBY-NC-ND), where it is permissible to download and share the work provided it is properly cited. The work cannot be changed in any way or used commercially without permission from the journal.

markers on a day-to-day level to lower the burden for participants. A useful noninvasive source for inflammatory markers is 24-hour urine (19,20), which can give information on inflammatory status during the whole day, instead of at a single time point. Also, a day-to-day sampling design provides the possibility of studying within-subject associations between somatic symptoms, inflammation, and sleep. Studying within-subject patterns over time can uncover interindividual differences. For instance, some individuals could be “resistant” to sleep disturbances, whereas others could have strong inflammatory responses to sleep disturbances leading to more somatic symptoms.

In this proof-of-principle study, we will explore individual differences in the direction and the strength of the association between sleep, inflammatory markers, and somatic symptoms. We are interested in the associations between normal daily fluctuations in sleep, inflammatory markers, and somatic symptoms. To this end, we performed time series analyses of sleep, inflammatory markers, and somatic symptoms in 10 healthy individuals of whom we collected daily information for 63 days on sleep duration, total output of inflammatory markers per day, and somatic symptoms. Contemporaneous and lagged associations between sleep, inflammatory markers, and somatic symptoms were studied within individuals using unified structural equation modeling (uSEM).

METHODS

Participants

This longitudinal prospective observational study included 10 healthy participants, consisting of 3 men and 7 women. They were recruited via poster adverts displayed on multiple places in Groningen in the Netherlands. The study took place from July 9, 2012, to March 10, 2013. Exclusion criteria were the existence of somatic/mental illnesses or the use of medication other than oral contraceptives or acetaminophen. For 63 consecutive days, 24-hour urine and electronic diary data about sleep duration and somatic symptoms were collected. Also, participants were asked daily to provide information on health or other relevant circumstances. Data collection was pre-pandemic. Participants received a reward of €5 per day that all measurements were completed. The study protocol was approved by the Medical Ethics Committee of the University Medical Center Groningen in the Netherlands (NL39630.042.12). All participants gave written informed consent, this included a clause in the protocol that stated that, after the study was closed, the key to identify individuals from research data was destroyed, and all data and samples were released for further research goals.

Sleep Duration

Sleep duration was measured using the morning part of the Pittsburgh Sleep Diary (21). Each morning, participants filled out a Web-based electronic diary for sleep duration the night before. This diary contained the moment of falling asleep and waking up and a question about being awake during the night. Sleep duration was estimated by calculating the difference in minutes between falling asleep and waking up minus the number of wakeful minutes during the night.

Inflammatory Markers

CRP, interferon- α (IFN- α), and interleukin 1 receptor antagonist (IL-1RA) were chosen as immune markers of interest, based on availability (measurable in urine) and findings in previous research.

Higher CRP and interleukin-6 levels were associated with sleep disturbances (6). Administration of IFN- α has a disrupting effect on sleep (7,8). IL-1RA was increased after sleep deprivation (9–11), whereas administering IL-1RA resulted in deeper sleep (10). These inflammatory markers were also associated with somatic symptoms (7,12–16). Urine was collected daily in two portions: the night and the subsequent-day portion. The night portion consisted of the “first morning void” and all urine voided during the night. The day portion consisted of the remaining voids of the awakening time until bedtime. Urine was collected in urine collection containers. Every other day, a researcher collected the samples and transferred them to the laboratory. The urine was stored at -80°C until laboratory analysis, which was done in April till June of 2015. The night portion and the subsequent-day portion together were considered as a 24-hour urine sample, but samples of the night and day portion were analyzed separately in the laboratory. By use of magnet bead multiplex assays with the Luminex 200 analyzer, levels of CRP, IFN- α , and IL-1RA levels were analyzed. The total output of inflammatory markers in 24-hour urine was calculated with the following formula: total concentration of the night portion (pg/ml) \times total output of the night portion (ml) + total concentration of the day portion (pg/ml) \times total output of the day portion (ml). Inflammatory markers remain stable in collected urine and fluctuate from day-to-day (19,20,22). The 24-hour urinary creatinine output was used to assess completeness of the 24-hour urine samples; cases were excluded from further analyses when 24-hour urine samples were incomplete. A sample was considered incomplete when the 24-hour creatinine output was lower than 2 standard deviations from the persons own mean, as described before (23).

Somatic Symptoms

Somatic symptoms were measured using items of the Patient Health Questionnaire-15 (PHQ-15), with answering options on a 7-point Likert scale (24). The following 12 somatic symptoms were assessed: stomach pain; back pain; pain in arms, legs, or joints; headaches; chest pain; dizziness; fainting spells; feeling heart pound or race; shortness of breath; constipation, loose bowels, or diarrhea; nausea, gas or indigestion; and feeling tired or having low energy. Score ranged from 0 to 72. We did not include PHQ-15 items related to menstruation or sexual intercourse because we considered these not suitable for daily assessments; the item on sleep problems was not included because of overlap with the Pittsburgh Sleep Diary. Participants indicated in the evening to which extent they experienced each somatic symptom during the day that just passed. The scores on the somatic symptoms were summed resulting in a total somatic symptoms score (SS-score) reflecting the severity of somatic symptoms on that day. Sum scores as an outcome of this questionnaire are more often used (25), although we are not aware of the PHQ-15 being used in daily diary studies. If measurement error is large (r) in a time series setting, this could lead to loss of power and spurious results.

Data Preparation

Observations more than two standard deviations below or above average were considered outliers, but only removed if these values were unrealistically high or could not be explained within the context of other values (23). This was the case for days 10, 22, and 42 for ID1; days 5, 25, and 26 for ID4; and days 23 and 24 for ID6. Another reason to remove data points was infection, for example,

ID3 had cystitis on 6 consecutive days (days 4–9). The following urine samples were excluded from further analyses because of incomplete urine samples based on creatinine values: days 23, 24, 28, 29, and 32 for ID1; day 42 for ID2; day 63 for ID5; day 22 for ID6; days 1 and 34 for ID7; day 56 for ID8; day 53 for ID9; and day 40 for ID10. Because only a small proportion of the urine samples was missing and none of the diary items, we choose to delete the items considered as incomplete and not to impute them. There were no CRP values for ID7, ID8, ID9, and ID10 because of technical problems. For ID1, most IFN- α levels were close to zero and its exclusion resulted in greatly improved model fit.

Data Analysis

To study the within-subject relationship between sleep, inflammatory markers, and somatic symptoms, we used unified uSEM. uSEM is a statistical technique that can be used to study both contemporaneous and lagged relations between variables within individuals (26). uSEM is a data-driven approach that fits the exploratory nature of the current study very well. Variables included in the uSEM model consisted of an SS-score in the evening, sleep duration in the morning, and values from inflammatory markers from the night plus the following day. uSEM was applied using a package in Rstudio (version 3.5.1), called “GIMME” (version 0.7.6), with the complementary function “indSEM(.)”. This function identifies the model for each individual separately and does not use shared information between individuals, unlike the GIMME model (27). Contemporaneous associations are associations between variables during the same period. In our study, time is measured as days. To give an example, if there is a positive contemporaneous association between CRP and SS score, then this means that the higher today’s CRP is, the higher today’s SS score will be. Lagged associations on the contrary are associations between variables of a different period. In our study, we used a first-order lag. This means that we modeled how yesterdays’ events influence the situation today. Therefore, a negative lagged association between sleep and SS score, for instance, means that a higher sleep duration yesterday predicts a lower SS score today (i.e., on the next day). uSEM assumes that outcome variables are continuous with a distribution that approximates normality. If this model assumption could not be met, then variables were excluded as an outcome variable but could be used as a predictor variable. The fit of the models was evaluated based on the comparative fit index ≥ 0.95 , nonnormed fit index ≥ 0.95 , the root mean square error of approximation < 0.10 , and the standardized root mean square residual ≤ 0.0565 . A model was considered a good fit if at least two of four fit indices met the criteria (28). Often data were either log transformed or squared to improve model fit.

Model Building

Sleep duration and all three inflammatory markers were included as predictor and outcome in all models, with the exception of CRP in ID7–10 because of missing values, and IFN- α in ID1 because most IFN- α levels were close to zero and its exclusion resulted in greatly improved model fit. Variation in SS-scores was sufficient to include it as outcome in ID4, ID8, and ID10. In all other models, SS-scores were only included as predictor because its distribution deviated from normality due to infrequent experience of somatic symptoms. The models for all 10 individuals were

a very good fit, meeting the criteria on all four fit indices, except for nonnormed fit index in ID9 (0.9236) and ID10 (0.9397).

RESULTS

Descriptives

The descriptives of the 10 participants are shown in Table 1.

Figure 1 summarizes the significant associations that were found in each individual, also presenting the β of the associations.

Associations Between Sleep Duration and Inflammatory Markers

We found evidence for associations between sleep duration and inflammatory markers in four individuals. In two individuals, we found negative contemporaneous associations between sleep duration and IL-1RA (ID8 and ID9). In one individual, we found a negative lagged association between sleep duration and IL-1RA (ID2). In one individual, there was a negative lagged association between sleep duration and CRP (ID5) and in one individual between sleep duration and IFN- α (ID9). In two individuals who showed a negative association, we also found an opposite effect suggesting a negative feedback loop for sleep and inflammation. This was found for IL-1RA with a negative lagged association and a positive contemporaneous association (ID2) and with IFN- α with a positive and a negative lagged association (ID9). In six individuals, we found no associations between sleep duration and inflammatory marker levels.

Associations Between Inflammatory Markers and Somatic Symptoms

Associations between inflammatory markers and somatic symptoms were found in three individuals. Positive contemporaneous associations were found between SS-score and CRP in ID6, and between SS-score and IFN- α in ID8. We found a positive lagged association between SS-score and IL-1RA levels in ID10. In one individual (ID3), we found a negative contemporaneous association between SS-score and IL-1RA. In six individuals, no associations between SS-score and inflammatory markers were found.

Associations Between Sleep Duration and Somatic Symptoms

Associations between sleep duration and somatic symptoms were found in four individuals. We found negative contemporaneous associations between sleep and SS-score in two individuals (ID2 and ID7). In the other two individuals, we found the opposite effect, with a positive contemporaneous association between sleep and SS-score (ID9) and a positive lagged association between SS-score and sleep (ID10). Six individuals showed no associations between sleep and SS-score.

DISCUSSION

Our proof-of-principle study was the first to perform time series analyses of daily fluctuations in sleep duration, inflammatory markers, and somatic symptoms. We found a wide variety between individuals in the presence, direction, and strength of these associations. We showed that it is possible to analyze associations between biomarkers and symptoms within individuals. This is important because associations that only exist in a minority of

TABLE 1. Participant Characteristics

| | Participant ID | | | | | | | | | |
|----------------------|----------------|------------------|------------------|-----------------|---------------|----------------|------------------|----------------|------------------|------------------|
| | 1 | 2 | 3 | 4 | 5 | 6 | 7 | 8 | 9 | 10 |
| Sex | M | F | F | F | M | M | F | F | F | F |
| Age, y | 24 | 58 | 29 | 33 | 39 | 19 | 21 | 21 | 48 | 22 |
| CRP, pg/L | | | | | | | | | | |
| Median | 365.3 | 226.7 | 108.1 | 278.4 | 113.8 | 335.8 | NA | NA | NA | NA |
| (25th, 75th) | (281.5, 409.5) | (159.2, 332.1) | (69.0, 149.1) | (126.6, 384.87) | (87.7, 152.4) | (186.1, 711.8) | NA | NA | NA | NA |
| Range | 81.8–750.2 | 54.3–480 | 17.4–652.88 | 65.2–1326.3 | 45.5–396.4 | 53.7–52,322.25 | NA | NA | NA | NA |
| IL-1RA, pg/L | | | | | | | | | | |
| Median | 230.5 | 4220.1 | 2235.1 | 314.5 | 98.9 | 97.1 | 1655 | 417.6 | 2989.8 | 2050.5 |
| (25th, 75th) | (197.2, 280.0) | (3403.8, 5119.9) | (1633.4, 2966.0) | (218.7, 450.1) | (87.5–115.1) | (71.9, 150.9) | (1289.0, 2227.6) | (225.6, 592.0) | (2382.4, 3953.8) | (1520.7, 2537.5) |
| Range | 142.8–451.6 | 1749.4–7720.5 | 419.9–6411.9 | 122.8–877.8 | 53.2–226.1 | 41.9–288.7 | 472.0–4359.0 | 92.7–1832.8 | 1172.6–6567.7 | 803.2–5107.0 |
| IFN- α , pg/L | | | | | | | | | | |
| Median | 0 | 6.4 | 10.3 | 19.3 | 6 | 12.5 | 14.4 | 7.7 | 6.9 | 24.8 |
| (25th, 75th) | (0,0) | (9.8, 14.3) | (7.5, 15.0) | (11.4, 30.2) | (0.0, 19.3) | (7.0, 26.5) | (7.6, 20.4) | (2.8, 14.8) | (3.8, 9.4) | (12.9, 36.6) |
| Range | 0–39 | 1.9–29.0 | 0.0–52.4 | 0.8–79.9 | 0–58.1 | 0.0–150.0 | 1.2–36.9 | 0.0–53.5 | 0.9–20.5 | 1.7–69.2 |
| Sleep duration, min | | | | | | | | | | |
| Median | 520 | 480 | 475 | 450 | 515 | 427 | 505 | 480 | 375 | 453 |
| (25th, 75th) | (450, 626) | (455, 510) | (440, 517) | (400, 485) | (455, 550) | (355, 486) | (465, 545) | (350, 535) | (330, 445) | (427, 485) |
| Range | 345–720 | 310–580 | 359–593 | 210–540 | 298–650 | 192–630 | 185–680 | 110–665 | 80–650 | 332–680 |
| SS-score | | | | | | | | | | |
| Median | 0 | 1 | 1 | 5 | 0 | 0 | 0 | 3 | 0 | 3 |
| (25th, 75th) | (0, 0) | (0, 2) | (0, 2) | (3, 7) | (0, 0) | (0, 0) | (0, 1) | (2, 7) | (0, 2) | (2, 7) |
| Range | 0–5 | 0–7 | 0–11 | 0–26 | 0–4 | 0–6 | 0–7 | 0–19 | 0–7 | 0–15 |

CRP = C-reactive protein; IL-1RA = interleukin 1 receptor antagonist; IFN- α = interferon α ; SS-score = somatic symptom score.

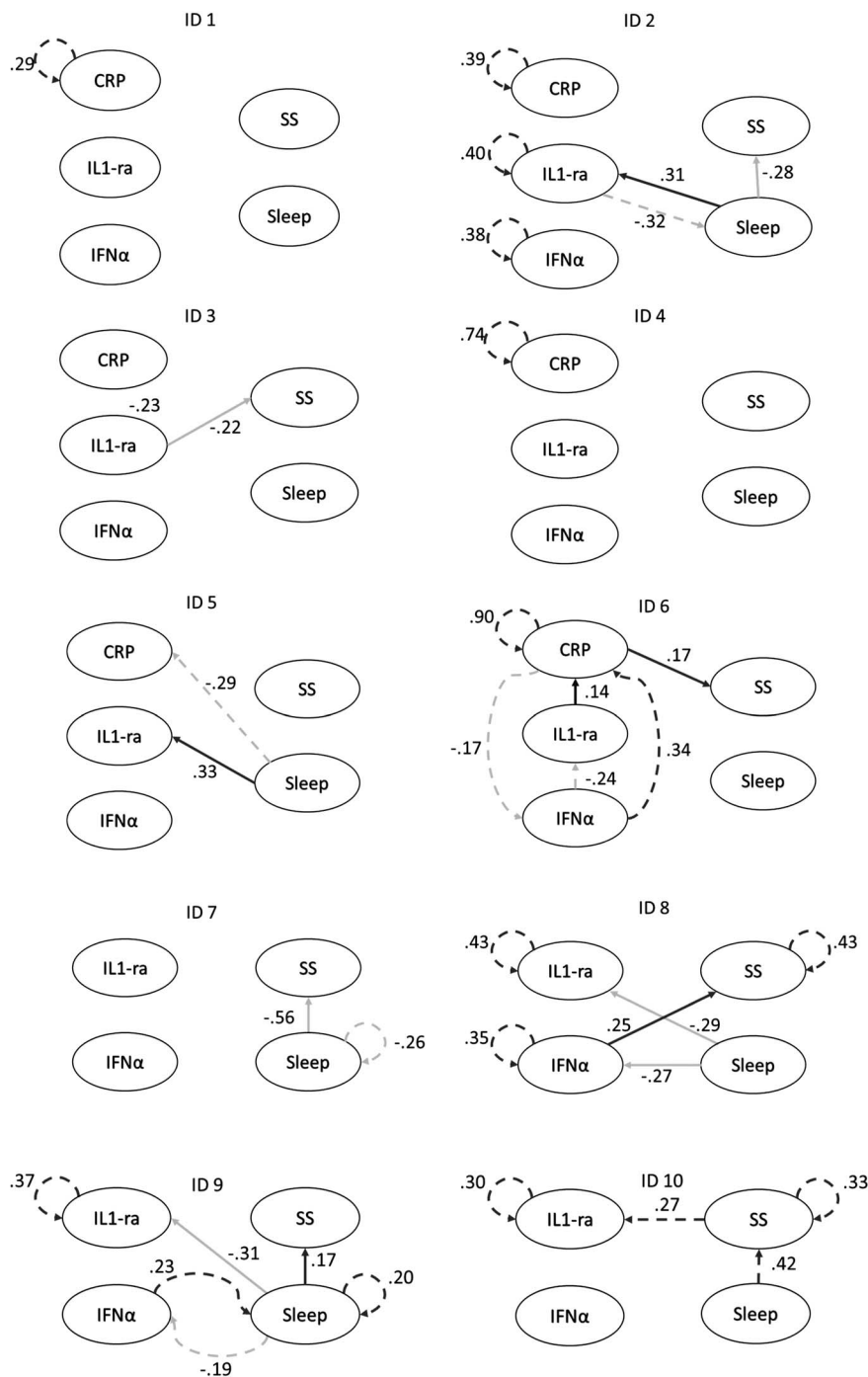

FIGURE 1. Overview of associations in all individuals. β values of significant correlations are reported. Dark gray lines show negative associations, light gray lines show positive associations, straight lines show contemporaneous associations, and dotted lines show lagged associations. A circular arrow toward the same variable means an autocorrelation, so higher values on 1 day predicted higher values the following days. CRP = C-reactive protein; IFN- α = interferon α ; IL1-ra = interleukin 1 receptor antagonist; SS = somatic symptom score.

individuals will not be identified with classical designs based on groups.

A major strength of this study is its duration of 63 days, which created an extensive time series of the variables of interest. Another strength of this study is the healthy study population, which provides

results on normal daily fluctuations in sleep, inflammatory markers, and somatic symptoms. A third strength is the data-driven statistical approach, because it allows for differences between individuals and can be used to generate new hypotheses (29). Lastly, we used urine for the assessment of the inflammatory state, which reflects the

inflammatory status of the entire day instead of a short time point, as is the case with blood sample analysis (19,20). However, urine analysis can also be seen as a limitation because it is not known how urine levels correlate with blood levels. This study also had some other limitations. First, the database is small with 10 participants, and it is missing CRP measures in four individuals because of technical problems. Second, our sleep duration was measured with a questionnaire, making it subjective and vulnerable to recall bias. We also did not analyze sleep quality. In our sleep score, we did not account for nightly awakenings and therefore might overestimate the total duration of sleep in people who suffer from longer or frequent nightly awakenings. Third, because our study was conducted in a healthy population, some individuals did not experience somatic symptoms for several consecutive days. This allowed us to only model the SS score as a predictor variable in the time series models of these specific individuals and not as an outcome variable. Also, we could not include time lags of more than 1 day, even though it is likely that these variables could influence each other over a longer period. Furthermore, we chose to remove data in which a participant had a cystitis. One could argue that a cystitis influences sleep and inflammation and somatic symptoms, and it is interesting to know how these patterns are in this case. However, these days would influence the general model, without providing detailed information on this specific period. Lastly, studies have shown that there are great differences between research groups in statistical approaches for time series analyses (29,30). However, the “GIMME” package in R allows for a relatively standardized approach that has been used in many network and time series data analyses (28,31).

The most striking finding of this study is the large individual difference in associations that we found. Associations existed between sleep duration, inflammatory markers and somatic symptoms, but varied among the individuals in the presence, strength, and direction. This is in line with inconsistencies in findings in current literature on group-level associations between inflammatory markers and sleep (6,32–35), as well as on inflammatory markers and somatic symptoms (14,15,36,37).

Starting with literature on sleep and inflammatory markers, group-level evidence shows heterogeneity in results on sleep and CRP levels (32–34), even though study samples have been large enough to make sampling error an unlikely explanation for the heterogeneity. Maybe this could be due to differences in study populations in other factors such as age, smoking, or body mass index, even though these factors were included as covariates in the regression models of both studies.

Just like with sleep, we also found a great variability in the associations between inflammatory markers and somatic symptoms. Earlier studies on inflammatory markers and somatic symptoms focused mostly on CRP. It was found in population-based cohorts that CRP was associated with functional SS-scores only in specific subsets of somatic symptoms (14,15). However, because of our study design, we were not able to study symptom clusters or specific symptoms.

The association between sleep duration and somatic symptoms also differed greatly across individuals in our study. In earlier large cohort studies, sleep disturbances were found to be significant predictors of somatic symptoms (1,3). Because somatic symptoms could not be included as outcome in many of our models, we should interpret our results as somatic symptoms influencing sleep.

Thus, the associations between sleep and inflammatory markers and between inflammatory markers and somatic symptoms show heterogeneity when studying them in large cohorts at the group level, as well as when studying them on the individual level using time series data. The findings in our study suggest that associations between sleep, inflammation, and somatic symptoms differ greatly among individuals, not only in presence but also in direction of the association. It seems unlikely on a pathophysiological level that associations between sleep, inflammation, and somatic symptoms can go in opposite directions among individuals. A possible explanation for these contradictory findings could be that there are other factors in play that could make individuals more vulnerable for the effects of sleep on inflammation and somatic symptoms. Even though this seems unlikely, the “Yule Simpson effect” teaches us that it is possible that when confounding factors are not included, the direction of certain effects can change when these factors are included in a later stage (38).

In conclusion, this study found a wide variety of associations between sleep duration, inflammatory markers, and somatic symptoms in eight individuals. Only two individuals showed no association between sleep, inflammation, and somatic symptoms. The findings of the current study generated a within-individual look on the studied associations, which may be of importance for the interpretation of current literature and for future study designs.

Our study was a proof-of-principle study and there performed in only 10 individuals. Because we analyzed only within-individual effects, the power of our statistical analysis is derived from the amount of time points, not the amount of people. Time series analysis can be done with a minimum of 30 time points, although larger numbers of observations provide more statistical power and yield more reliable results (39). It would also be interesting to include more factors in intraindividual analyses, such as mood, experience of stress, or a daily functioning score, to get a more complete assessment of the impact of the associations that we found. However, the more variables included in the model, the longer the time series need to be (i.e., the more observations are needed).

Future studies should repeat our approach in a larger population. If time series of a sufficiently large number of individuals are analyzed, it becomes possible to identify clusters of people that display similar patterns over time. This allows to study which between-individual differences (e.g., sex, age, educational level, life events) explain cluster membership and thus knowledge that is useful at the population level or subgroup level. The power for these between-individual analyses is derived from the number of individuals, and thus, such studies need to be large (e.g., $n > 100$). One application of our approach is to study patients with persistent somatic symptoms, to find out whether fluctuations in their symptoms can be related to fluctuations in biomarkers or other symptoms, thereby potentially identifying targets of treatment. Thus, such studies within individuals can be seen as a bridge between findings in science and clinical practice.

Source of Funding and Conflicts of Interest: All authors declare no conflicts of interest. H.M.S. received a grant from the De Cock–Hadders Foundation (2016–62). The Espria Academy, a health care group in the Netherlands consisting of multiple companies targeted mainly at the elderly population (<https://www.espria.nl/>), provided funding for the salary of H.M.S. J.G.M.R. received a grant from the Innovation Fund Health Insurances, the Netherlands

(grant number 2619). The funders had no role in study design, data collection and analysis, decision to publish, or preparation of the manuscript.

REFERENCES

- Zhang J, Lam SP, Li SX, Tang NL, Yu MWM, Li AM, et al. Insomnia, sleep quality, pain, and somatic symptoms: sex differences and shared genetic components. *Pain* 2012;153:666–73.
- Bonvanie IJ, Oldehinkel AJ, Rosmalen JGM, Janssens KAM. Sleep problems and pain: a longitudinal cohort study in emerging adults. *Pain* 2016;157:957–63.
- Schlarb AA, Classen M, Hellmann SM, Vogele C, Gulewitsch MD. Sleep and somatic complaints in university students. *J Pain Res* 2017;10:1189–99.
- Cappuccio FP, Cooper D, D'Elia L, Strazzullo P, Miller MA. Sleep duration predicts cardiovascular outcomes: a systematic review and meta-analysis of prospective studies. *Eur Heart J* 2011;32:1484–92.
- Cappuccio FP, D'Elia L, Strazzullo P, Miller MA. Sleep duration and all-cause mortality: a systematic review and meta-analysis of prospective studies. *Sleep* 2010;33:585–92.
- Irwin MR, Olmstead R, Carroll JE. Sleep disturbance, sleep duration, and inflammation: a systematic review and meta-analysis of cohort studies and experimental sleep deprivation. *Biol Psychiatry* 2016;80:40–52.
- Sleijfer S, Bannink M, Van Gool AR, Kruit WH, Stoter G. Side effects of interferon-alpha therapy. *Pharm World Sci* 2005;27:423–31.
- Loftis JM, Patterson AL, Wilhelm CJ, McNett H, Morasco BJ, Huckans M, et al. Vulnerability to somatic symptoms of depression during interferon-alpha therapy for hepatitis C: a 16-week prospective study. *J Psychosom Res* 2013;74:57–63.
- Schmidt EM, Linz B, Diekelmann S, Besedovsky L, Lange T, Born J. Effects of an interleukin-1 receptor antagonist on human sleep, sleep-associated memory consolidation, and blood monocytes. *Brain Behav Immun* 2015;47:178–85.
- Voderholzer U, Fiebich BL, Dersch R, Feige B, Piosczyk H, Kopasz M, et al. Effects of sleep deprivation on nocturnal cytokine concentrations in depressed patients and healthy control subjects. *J Neuropsychiatry Clin Neurosci* 2012;24:354–66.
- Frey DJ, Fleshner M, Wright KP Jr. The effects of 40 hours of total sleep deprivation on inflammatory markers in healthy young adults. *Brain Behav Immun* 2007;21:1050–7.
- Andrés-Rodríguez L, Borràs X, Feliu-Soler A, Pérez-Aranda A, Angarita-Osorio N, Moreno-Peral P, et al. Peripheral immune aberrations in fibromyalgia: a systematic review, meta-analysis and meta-regression. *Brain Behav Immun* 2020;87:881–9.
- Cho HJ, Seeman TE, Bower JE, Kiefe CI, Irwin MR. Prospective association between C-reactive protein and fatigue in the coronary artery risk development in young adults study. *Biol Psychiatry* 2009;66:871–8.
- Tak LM, Bakker SJ, Slaets JP, Rosmalen JG. Is high-sensitive C-reactive protein a biomarker for functional somatic symptoms? A population-based study. *Brain Behav Immun* 2009;23:1014–9.
- Jonker I, Schoevers R, Klein H, Rosmalen J. The association between herpes virus infections and functional somatic symptoms in a general population of adolescents. The TRAILS study. *PLoS One* 2017;12:e0185608.
- Tsigos C, Stefanaki C, Lambrou GI, Boschiero D, Chrousos GP. Stress and inflammatory biomarkers and symptoms are associated with bioimpedance measures. *Eur J Clin Invest* 2015;45:126–34.
- Ho KKN, Simic M, Cvancarova Smástuen M, de Barros Pinheiro M, Ferreira PH, Bakke Johnsen M, et al. The association between insomnia, C-reactive protein, and chronic low back pain: cross-sectional analysis of the HUNT study, Norway. *Scand J Pain* 2019;19:765–77.
- Labrecque N, Cermakian N. Circadian clocks in the immune system. *J Biol Rhythms* 2015;30:277–90.
- Stiegel MA, Pleil JD, Sobus JR, Morgan MK, Madden MC. Analysis of inflammatory cytokines in human blood, breath condensate, and urine using a multiplex immunoassay platform. *Biomarkers* 2015;20:35–46.
- Schenk HM, van Ockenburg SL, Nawijn MC, De Jonge P, Rosmalen JGM. Identification of inflammatory markers suitable for non-invasive, repeated measurement studies in biobehavioral research: a feasibility study. *PLoS One* 2019;14:e0221993.
- Monk TH, Reynolds CF, Kupfer DJ, Buysse DJ, Coble PA, Hayes AJ, et al. The Pittsburgh Sleep Diary. *J Sleep Res* 1994;3:111–20.
- Liu J, Zhao Z, Willcox MD, Xu B, Shi B. Multiplex bead analysis of urinary cytokines of type 2 diabetic patients with normo- and microalbuminuria. *J Immunoassay Immunochem* 2010;31:279–89.
- van Ockenburg SL, Schenk HM, van der Veen A, van Rossum EF, Kema IP, Rosmalen JG. The relationship between 63days of 24-h urinary free cortisol and hair cortisol levels in 10 healthy individuals. *Psychoneuroendocrinology* 2016;73:142–7.
- Kroenke K, Spitzer RL, Williams JB. The PHQ-15: validity of a new measure for evaluating the severity of somatic symptoms. *Psychosom Med* 2002;64:258–66.
- Zijlema WL, Stolk RP, Löwe B, Rief W, BioSHaRE, White PD, Rosmalen JG. How to assess common somatic symptoms in large-scale studies: a systematic review of questionnaires. *J Psychosom Res* 2013;74:459–68.
- Gates KM, Molenaar PC, Hillary FG, Ram N, Rovine MJ. Automatic search for fMRI connectivity mapping: an alternative to granger causality testing using formal equivalences among SEM path modeling, VAR, and unified SEM. *Neuroimage* 2010;50:1118–25.
- Lane ST, Gates KM. Automated selection of robust individual-level structural equation models for time series data. *Struct Equ Model Multidiscip J* 2017;24:768–82.
- Dotterer HL, Hyde LW, Shaw DS, Rodgers EL, Forbes EE, Beltz AM. Connections that characterize callousness: affective features of psychopathy are associated with personalized patterns of resting-state network connectivity. *Neuroimage Clin* 2020;28:102402.
- Ariens S, Ceulemans E, Adolf JK. Time series analysis of intensive longitudinal data in psychosomatic research: a methodological overview. *J Psychosom Res* 2020;137:110191.
- Bastiaansen JA, Kunkels YK, Blaauw FJ, Boker SM, Ceulemans E, Chen M, et al. Time to get personal? The impact of researchers choices on the selection of treatment targets using the experience sampling methodology. *J Psychosom Res* 2020;137:110211.
- Beltz AM, Gates KM. Network mapping with GIMME. *Multivariate Behav Res* 2017;52:789–804.
- Lee HW, Yoon HS, Yang JJ, Song M, Lee JK, Lee SA, et al. Association of sleep duration and quality with elevated hs-CRP among healthy Korean adults. *PLoS One* 2020;15:e0238053.
- Ghilotti F, Bellocco R, Trolle Lageros Y, Thorson A, Theorell-Haglöw J, Åkerstedt T, et al. Relationship between sleep characteristics and markers of inflammation in Swedish women from the general population. *J Sleep Res* 2021;30:e13093.
- Richardson MR, Churilla JR. Sleep duration and C-reactive protein in US adults. *South Med J* 2017;110:314–7.
- He L, Yang N, Ping F, Xu L, Li W, Li Y, et al. Long sleep duration is associated with increased high-sensitivity C-reactive protein: a nationwide study on Chinese population. *Diabetes Metab Syndr Obes* 2020;13:4423–34.
- Hagen K, Stovner LJ, Nilsen KB, Kristoffersen ES, Winsvold BS. The impact of C-reactive protein levels on headache frequency in the HUNT study 2006–2008. *BMC Neurol* 2019;19:229.
- Rodríguez-Pinto I, Agmon-Levin N, Howard A, Shoenfeld Y. Fibromyalgia and cytokines. *Immunol Lett* 2014;161:200–3.
- Hernán MA, Clayton D, Keiding N. The Simpson's paradox unraveled. *Int J Epidemiol* 2011;40:780–5.
- Lutkepohl H. *New Introduction to Multiple Time Series Analysis*. 2nd ed. New York, NY: Springer; 2007.