



# **ASHESI UNIVERSITY**

**Playground Design for Kayayo Day Care Centre**

**CAPSTONE PROJECT**

B.Sc. Mechanical Engineering

**Oluwadamilola Gerald Labiran**

**2021**

**ASHESI UNIVERSITY**

**Playground Design for Kayayo Day Care Centre**

**CAPSTONE PROJECT**

Capstone Project submitted to the Department of Engineering, Ashesi University College in partial fulfilment of the requirements for the award of Bachelor of Science degree in Mechanical Engineering.

**Oluwadamilola Gerald Labiran**

**2021**

## Declaration

I hereby declare that this capstone is the result of my original work and that no part of it has been presented for another degree in this university or elsewhere.

Candidate's Signature:

.....

Candidate's Name:

.....

Date: .....

I hereby declare that preparation and presentation of this capstone were supervised in accordance with the guidelines on supervision of capstone laid down by Ashesi University College.

Supervisor's Signature:

.....

Supervisor's Name:

.....

Date: .....

## **Acknowledgements**

To Mrs Rose Dodd, who inspired this project and whose encouragement was unmatched during the development, I am very grateful for your support. To my supervisor, Dr Stephen Armah, whose academic advice and feedback helped me undertake this project.



## **Abstract**

Playgrounds are easily the most common and important forms of entertainment for young children. They provide a means for children to develop physically, through the movements made during play, and socially, through their interactions with other children while they play. These activities are all done within a safe environment that has been engineered to look aesthetically pleasing to children and ensure their safety while they have fun. However, despite their apparent benefits, the playgrounds available in Accra and other West African cities are very few, lack design creativity, and are often poorly maintained. This paper showcases a creative design for a set of playground structures for young children and the analysis done to ensure its safety. The playground was designed for the Kayayo day-care centre.

## Table of Contents

<b>Declaration.....</b>	<b>iii</b>
<b>Acknowledgements .....</b>	<b>iv</b>
<b>Abstract.....</b>	<b>v</b>
<b>Table of Contents .....</b>	<b>vi</b>
<b>Table of Figures.....</b>	<b>viii</b>
<b>Table of Tables .....</b>	<b>xi</b>
<b>Chapter 1: Introduction .....</b>	<b>1</b>
1.1 Background .....	1
1.2 Motivation .....	1
1.3 Problem Definition.....	1
1.4 Objectives.....	2
1.5 Proposed Solution and Justification .....	2
1.6 Requirements.....	2
1.6.1 Functional Requirements .....	2
1.6.2 Technical Requirements.....	3
1.7 Scope .....	3
<b>Chapter 2: Literature Review and Related Work .....</b>	<b>5</b>
2.1 Interactive Slide: An Interactive Playground to Promote Physical Activity and Socialisation of Children.....	5
2.2 Using interviews and peer pairs to better understand how school environments affect young children’s playground physical activity levels: a qualitative study.....	5
2.3 Risk, challenge and safety: implications for play quality and playground design.....	6
2.4 Column, Beam and Finite Element Analysis .....	7
<b>Chapter 3: Design and Methodology.....</b>	<b>8</b>
3.1 Current Solution.....	8
3.2 Evaluation Criteria .....	8
3.3 Alternative Designs .....	9
3.4 Evaluation Matrix.....	16
<b>Chapter 4: Analysis.....</b>	<b>17</b>
4.1 Analytical .....	17
4.1.1 Structure 1 Suspended Tire Platform .....	17
4.1.2 Structure 2 Dome/Calabash .....	19
4.1.3 Structure 3 Slide.....	19
4.1.4 Structure 4 Trotro.....	20
4.2 Numerical .....	20
<b>Chapter 5: Results and Discussion .....</b>	<b>21</b>

5.1 Structure 1 .....	21
5.2 Structure 2 .....	26
5.3 Structure 3 .....	29
5.4 Structure 4 .....	31
<b>Chapter 6: Conclusion and Future Works .....</b>	<b>33</b>
<b>References .....</b>	<b>34</b>
<b>Appendix A .....</b>	<b>35</b>
<b>Appendix B .....</b>	<b>50</b>

## Table of Figures

Figure 1 Dimensions of the compound area in cm .....	3
Figure 2 First view of the compound.....	8
Figure 3 Second view of the compound .....	8
Figure 4 Hand sketched Design A .....	10
Figure 5 CAD model of Design A .....	10
Figure 6 Hand sketched Design B structures.....	11
Figure 7 Suspended tire platform.....	11
Figure 8 Sketches of joints for the suspended tire platform .....	12
Figure 9 Detailed sketch of foothold for children.....	12
Figure 10 Trotro structure sketch.....	13
Figure 11 CAD model of the suspended tire platform.....	13
Figure 12 CAD model of the dome (calabash) .....	14
Figure 13 CAD model of the slide platform .....	14
Figure 14 CAD model of trotro structure .....	15
Figure 15 Static Maximum stress on Metal Frame.....	21
Figure 16 Factor of Safety of Maximum Static load .....	22
Figure 17 Static Minimum Stress on Metal Frame .....	22
Figure 18 Factor of Safety of Minimum Static load.....	23
Figure 19 Damage percentage after fatigue analysis .....	23
Figure 20 Total life cycle of the structure.....	24
Figure 21 Stress distribution of maximum static load .....	24
Figure 22 FOS of maximum static load.....	25
Figure 23 Damage percentage after 1 million cycles.....	25
Figure 24 Total life cycle of hook.....	26

Figure 25 FOS of Static Load .....	27
Figure 26 Stress distribution of Static load.....	28
Figure 27 Damage percentage after 1 million cycles.....	28
Figure 28 Life cycle after Fatigue test .....	29
Figure 29 Stress Distribution on the platform during static load.....	30
Figure 30 Factor of Safety of the platform during static load.....	30
Figure 31 Damage percentage on the platform after 1 million cycles.....	31
Figure 32 Life cycle of the platform after fatigue analysis.....	31
Figure 33 Stress Distribution across the Bus frame under static load .....	32
Figure 34 FOS of the bus frame under static load .....	32
<b>Appendix A</b>	
Figure A 1 Static Load Analysis on a single wooden beam from Structure 1 .....	35
Figure A 2 Stress Analysis on wooden beam from Structure 1 .....	36
Figure A 3 Material Selection and Design Solution .....	37
Figure A 4 Load Analysis on new Metal Beam for structure 1 .....	38
Figure A 5 Stress Analysis, Material Selection and Design Solution for the metal beam .....	39
Figure A 6 Fatigue Load Analysis, Stress Analysis and Material Properties for the metal beam in Structure 1 .....	40
Figure A 7 Design Solution for the metal beam .....	41
Figure A 8 Static Load and Stress Analysis on the metal hook for the tire rod in Structure 1	42
Figure A 9 Continuation of Stress Analysis .....	43
Figure A 10 Material Selection and Design Solution .....	44
Figure A 11 Fatigue Load and Stress Analysis, and Material Selection .....	45
Figure A 12 Design Solution for Fatigue Analysis.....	46

Figure A 13 Structure 3 Platform Static Load Analysis, Stress Analysis, Material Selection and Design Solution.....	47
Figure A 14 Platform Fatigue Load and Stress Analysis, and Material Properties .....	48
Figure A 15 Design Solution for Fatigue Failure analysis .....	49

**Appendix B**

Figure B 1 Structure 1 Assembly Drawing and dimensions.....	50
Figure B 2 Tire platform Assembly Drawing and dimensions.....	51
Figure B 3 Structure 2 Part Drawing and dimensions .....	52
Figure B 4 Structure 3 Assembly Drawing and dimensions.....	53
Figure B 5 Structure Assembly Drawing and dimensions.....	54

## **Table of Tables**

Table 1.0: Evaluation Matrix of two designs.....	16
Table 2.0 Results of Analytical Calculations.....	21
Table 3.0 Hand calculated factors of safety in Structure 3 .....	29

## **Chapter 1: Introduction**

This chapter gives the background to the project, introduces the problem this project seeks to solve and the project's motivation. The objectives and scope of the project are also covered here.

### **1.1 Background**

Though it is widely accepted that play offers many benefits to children physically and socially [1], the design and construction of playgrounds for children in major African cities, including Accra, does not reflect this accepted fact. The first issue lies with the fact that there are very few playgrounds available to children in Accra. Most playgrounds available to children are usually in amusement parks, specific schools and shopping centres, with the few exceptions being some restaurants. Aside from the playgrounds found in amusement parks (which are still very few), their designs are very lacklustre and often not well suited to their environment.

Therefore, this project aims to design and analyse a playground structure that is visually appealing to children and can be made using locally sourced materials. This playground is meant to be utilised by children between the ages of 1-6 at the Kayayo day-care centre. It should be structurally sound and well designed.

### **1.2 Motivation**

This project would provide a design for an outdoor playground for the children of the day-care centre that do not have the opportunity to use playgrounds as an avenue of entertainment, exercise or a means to socialise.

### **1.3 Problem Definition**

There are currently very few well designed, publicly accessible playgrounds available for children in Accra. These playgrounds are often located in places like shopping malls, such as



the playground structures found in the A&C mall. However, those playgrounds are not easily accessible to children from less privileged backgrounds like the Kayayo children, neither are they located near the day-care centre.

#### **1.4 Objectives**

This project aims to design a playground structure or structures for the children of the Kayayo day-care centre.

- Design a playground structure or structures
- Analyse designs using analytical and numerical methods.
- Make adjustments to designs

#### **1.5 Proposed Solution and Justification**

The playground structure/structures would be designed to be built using materials that can be locally sourced to reduce cost. The structure's design will be sufficiently complex to inspire the children's imagination, aesthetically pleasing, and safe to use without risk of serious injury. Ideally, the design would not be too complex to be replicated by others and affordable to construct. Hence, making the possibility of multiple versions being constructed possible, which in turn would make more of these playgrounds available for children to access.

#### **1.6 Requirements**

##### **1.6.1 Functional Requirements**

The playground will need to be a unique structure or set of structures that the day-care centre children will find visually appealing. The playground should be suitable for children between the ages of 1 and 6. The playground should not have any sharp objects/sharp points that could puncture a child or any hazardous areas; for the safety of the children. The structure or structures should not be fixed to the compound in the event that they need to be disassembled

for removal. Ideally, the materials selected for the designs should be easily accessed in Accra and the designs not too complex to be built by welders or carpenters.

### 1.6.2 Technical Requirements

The playground structure should not have any region with a fall height greater than 1.5 metres. This height drastically reduces the chances of the children incurring any severe injury if they fall, as mentioned in an article by Norton [2]. The structure/structures should fit within the area of the compound available.

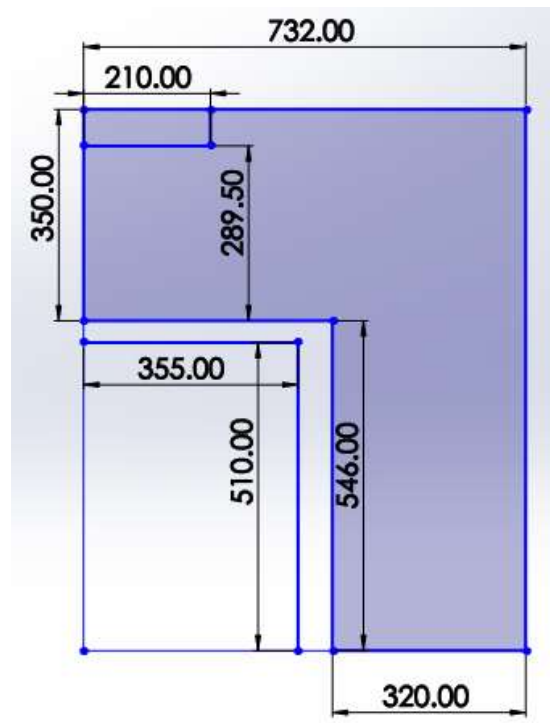

Figure 1 Dimensions of the compound area in cm

### 1.7 Scope

This project involves designing a playground structure or multiple structures used by the children of the Kayayo day-care centre. The structures should be analysed using analytical and numerical methods (Finite Element Analysis). The structure/structures should be designed to be built using wood, steel and rubber in tires. The dimensions of the structure/structures should

be within the limits of the compound of the day-care centre. They should not require any changes made to the property in the event of their construction outside of this project. The project should be undertaken under the assumption that the analysis results would be accurate enough to construct these structures. However, this is outside the scope of the project.

## **Chapter 2: Literature Review and Related Work**

In this chapter, the relevant literature used in the design and analysis of the structures is reviewed and annotated.

### **2.1 Interactive Slide: An Interactive Playground to Promote Physical Activity and Socialisation of Children**

This paper was based on a study focused on designing an interactive slide for a playground that could incorporate elements of technology that have become so common for children's entertainment with physical activity. The researchers designed a game that was projected onto the surface of an inflatable slide. The game could only be played via the physical interaction of the children with the objects projected. This physical interaction mostly involved the children climbing up and down the slide [1]. The researchers, while observing the behaviour of the children, also tried to record their physical activity. Unfortunately, a significant portion of their measurements was rendered useless. Their assumption on how the children would move around was proven wrong: the children would bounce around the slide instead of sliding down.

The experiment results showed that the children did show an interest in playing with equipment that incorporated modern technology into their designs. The researchers learnt that children's movement on a playground cannot always be predicted based on the design of the equipment. Hence, it would be useful to consider as many possible behaviours as possible when designing equipment for the sake of the children's safety. Additionally, it would also be beneficial to design a playground structure that can be used creatively by the children playing on it.

### **2.2 Using interviews and peer pairs to better understand how school environments affect young children's playground physical activity levels: a qualitative study**

In this paper, the researchers conducted multiple stakeholders involved in the design of school playgrounds. Principals, teachers, and students were all interviewed to understand what they considered a well-designed playground. Though all parties mentioned many variables, many of them were social variables that cannot be addressed with the design of the playground structure. Factors such as the lack of bullying and involvement of the supervising teacher during play were mentioned.

There was some helpful information mentioned concerning the actual design of the structure: having an open design that could be utilised in multiple scenarios/games, a safe and aesthetically pleasing design, and a quiet place. These were the school children's requirements when asked what they would like in a playground structure [3].

### **2.3 Risk, challenge and safety: implications for play quality and playground design**

This paper [4], written by Helen Little and David Eager, explores the importance of risk and challenge in children's play and the effects. The paper firstly discusses how the perception of risk and even risk itself plays a vital role in engaging children, especially on playgrounds. They mention that designing a playground that incorporates a level of risk to the children is helpful because it helps stimulate them. This risk ensures they do not get bored and also helps children discover their physical limits. Little and Eager state that the current trend of over-protective measures regarding playgrounds hinder the previously stated benefits. They state that while playground designers should consider safety standards, they should also avoid making their playgrounds "too safe" not to lose the children's interest. They provide evidence of this by interviewing thirty-eight children and getting their feedback on specific playground designs (categorised by how risky they appeared). The data they found showed that children genuinely prefer to engage in activities on playgrounds that appear challenging and risky, as opposed to very safe looking equipment.

## **2.4 Column, Beam and Finite Element Analysis**

The textbook Shigley's Mechanical Engineering Design [5] was used throughout this project. The textbook gives an excellent introduction to the topics of failure and the intricacies of predicting failure and designing against it. Information about the types of failure and the most sensitive materials to certain types of failures were obtained from this textbook. The equations for the calculations for failure (static and fatigue) were gotten from the textbook, and an understanding of the Finite Element Method used to analyse the structures numerically. The calculations can be found in Appendix A.

## Chapter 3: Design and Methodology

In this chapter, the alternative designs created are explained and compared. The preferred solution is chosen for further analysis.

### 3.1 Current Solution

Currently, the compound of the day-care is completely bare without any structures for the children to play on, as shown in the figures below.



*Figure 2 First view of the compound*



*Figure 3 Second view of the compound*

### 3.2 Evaluation Criteria

The designs would be evaluated based on aesthetics, the complexity of design, uniqueness, cost, suitability for toddlers and teaching possibilities. The design of the playground has to be

attractive to the eyes of the young children. According to the client, a unique design was preferred over a more generic playground. The complexity of the design will influence both the cost of the structure and the process of fabrication. Hence, a less complex design would be preferred as this would reduce the cost of the structure and the risk of a welder or carpenter making a mistake. The designs will also be judged on their suitability for toddlers: how the structure accommodates the physical limitations of young children. Lastly, the possibility of teaching occurring alongside playing will be rated between the designs, allowing the children to learn alongside their play.

### **3.3 Alternative Designs**

Using the dimensions of the compound, two different designs were created to utilise the client's available space. The first design was a singular tower structure that incorporated many activities through extensions, while the second design was a mix of 4 separate structures. The four separate structures included a suspended tire platform, a dome (calabash), a raised slide, and a trotro structure.

#### **3.3.1 Design A**

The initial sketch and 3D model of the first design can be seen below. This structure was designed to use as much of the space available with a singular structure. There were monkey bars in one area, a board of nailed tires for climbing, two storeys for children to stay in, and a slide from the top.



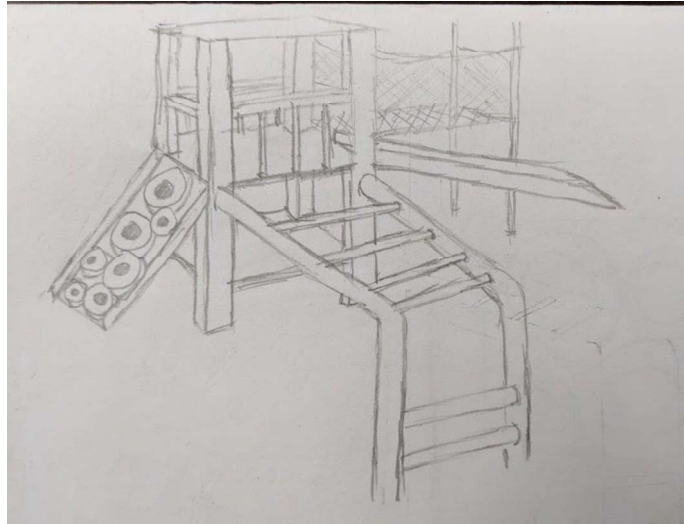

*Figure 4 Hand sketched Design A*



*Figure 5 CAD model of Design A*

### **3.3.2 Design B**

Design B was conceived using an idea opposite to that of Design A. Instead of a single main structure with multiple extensions, Design B is a set of individual structures separate from each other, as shown in Figure 6. The first structure shown in Figure 7 is the suspended tire platform. The structure was initially designed to be built using wood for most members as this would reduce the cost. The children's platforms would consist of a tire held up by wooden support, a

wooden cover over the top of the tire, and a steel rod that would hold the tire in the air. Figure 9 shows these features clearly in a sketch.

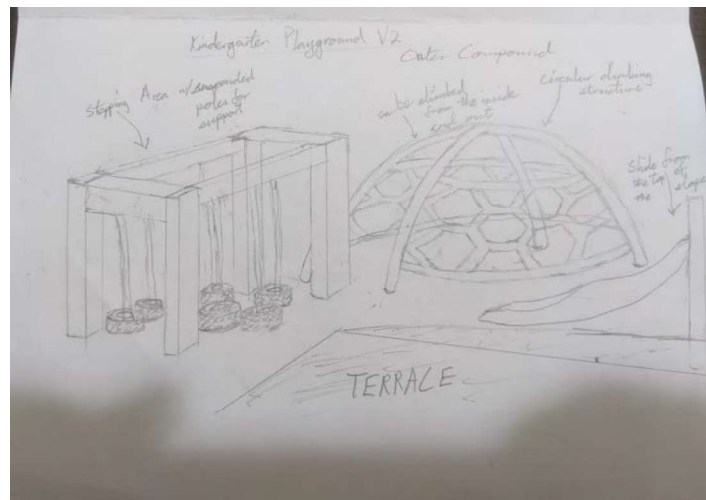

Figure 6 Hand sketched Design B structures

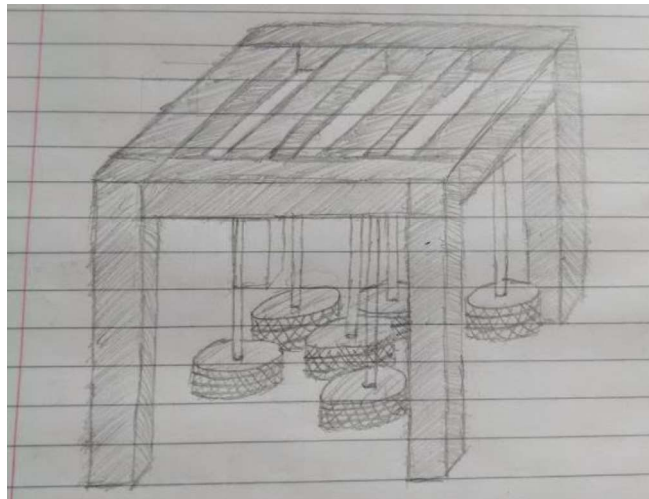

Figure 7 Suspended tire platform

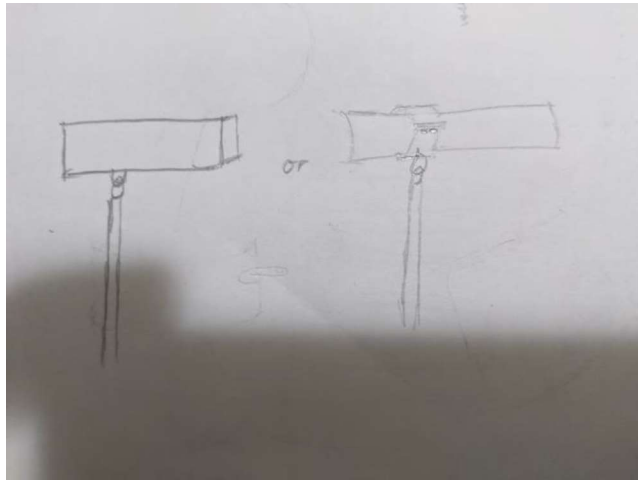

Figure 8 Sketches of joints for the suspended tire platform

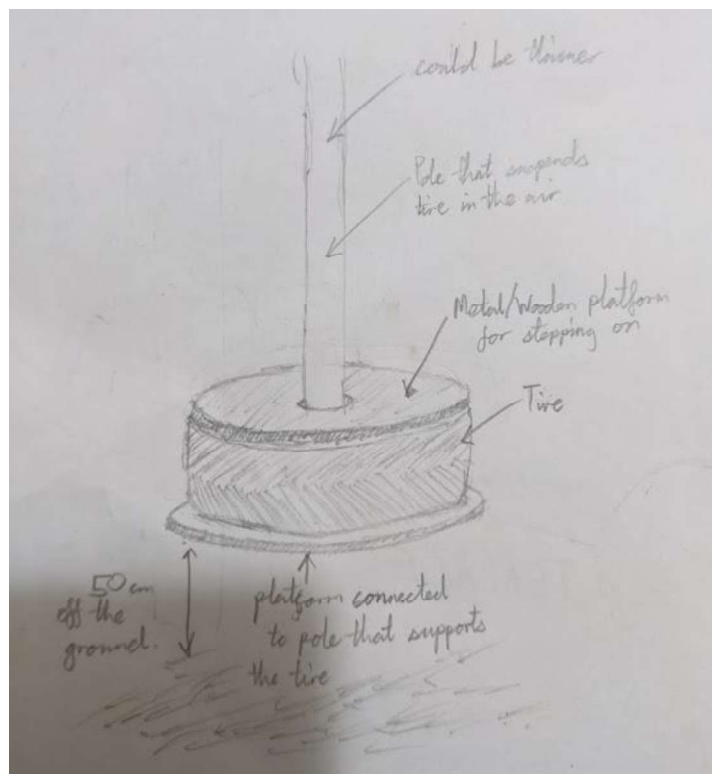

Figure 9 Detailed sketch of foothold for children

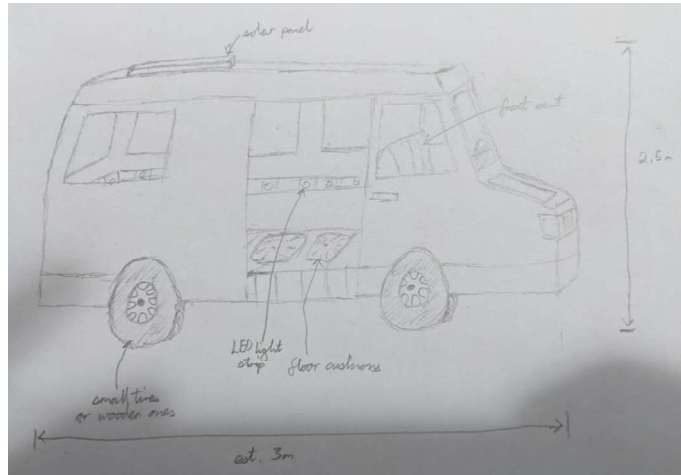

Figure 10 Troto structure sketch

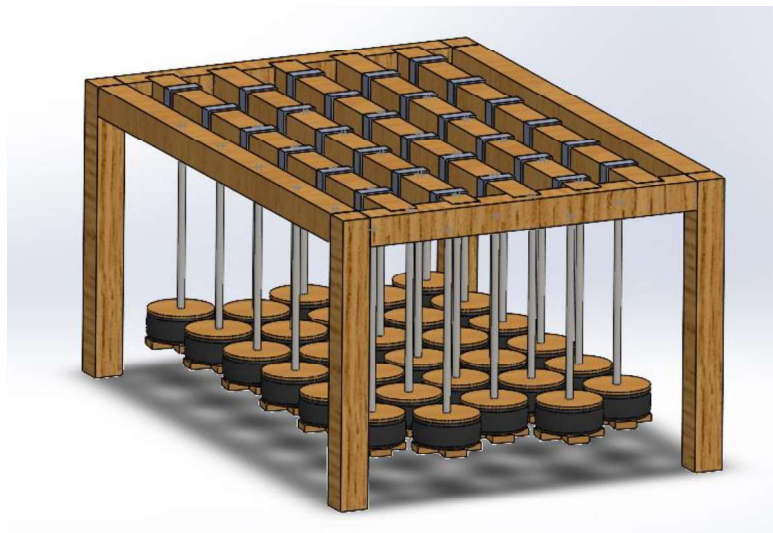
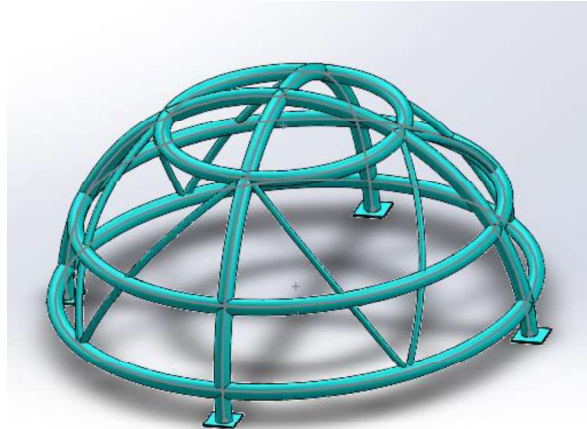

Figure 11 CAD model of the suspended tire platform



*Figure 12 CAD model of the dome (calabash)*



*Figure 13 CAD model of the slide platform*

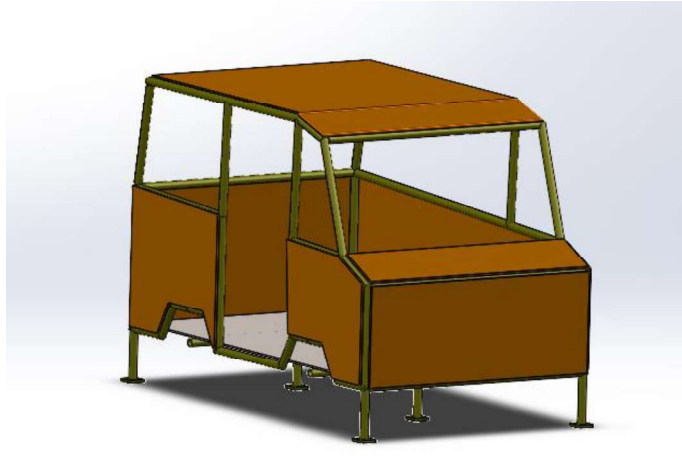

*Figure 14 CAD model of trotto structure*

The initial CAD models for all four structures of Design B are shown above.

### 3.4 Evaluation Matrix

Table 1.0 shows the decision matrix used to select the chosen design. Each design is evaluated based on the criteria stated in Section 3.2, and the designs are assigned a score between 1 to 5. The criteria are weighted based on their importance. The score given to each design is then reduced by the median value of the score range to remove any neutral scores.

Table 1.0: Evaluation Matrix of two designs

Criteria	Weight $w_i$	Design A		Design B	
		$r$	$w_i (r_i - 3)$	$r$	$w_i (r_i - 3)$
Aesthetic	0.2	3	0	4	0.2
Complexity of Design	0.1	3.5	0.05	3	0
Uniqueness	0.2	1	-0.4	3.5	0.1
Cost	0.1	3	0	3	0
Suitability for Toddlers	0.3	2	-0.3	4	0.3
Teaching Possibilities	0.1	2	-0.1	4	0.1
Total Score	1		-0.75		0.7

As shown by the matrix, the second design was chosen as the preferred design for the playground.

## Chapter 4: Analysis

In this chapter, the chosen design is analysed using analytical and numerical (FEA) methods.

### 4.1 Analytical

Analytical calculations were done to determine the safety of the structures and the accuracy of the dimensions. Each structure was analysed at the critical areas where failure was most likely to occur. Primarily, failure theories were used to check the factor of safety during static loading and repeated loading (failure by fatigue) in metal members.

#### 4.1.1 Structure 1 Suspended Tire Platform

In this structure, three critical areas were identified as the most at risk of failure. These areas were the wooden beams supporting each of the six tire platforms suspended in the air and the hook that attaches the tire rod to the beam.

##### 4.1.1.1 Beam

*Average weight of a 6 yr old: 21 kg*

*Tire platform: 34.4 kg*

*Total weight on one beam:  $34.4 + 21 = 55.4$  kg*

*Force on beam:  $55.4 * 9.81 = 543.5$  N*

Since wood is a semi-brittle material, the assumption was made that using a failure theory for brittle materials would serve as a reasonable estimate of the performance. Hence, the Maximum Normal Stress Theory (MNST) was used. No failure theory was used for fatigue loading as this was not a metal material.

From MNST,



$$n = \frac{S_{ut}}{\sigma_1}$$

Unfortunately, due to the nature of wood as a material and the variation of performance based on water content, the software (SOLIDWORKS) chosen for the Finite Element Analysis could not conduct any meaningful analysis of the behaviour of wood under static or fatigue loads. Hence, the wooden beams in Structure 1 were replaced with metal beams instead. 80x80x5 mm pipe was chosen as the new beam's measurement, and the subsequent material of choice was the AISI 1015 Cold Drawn Steel. The new beam was tested for static and fatigue loading using the Von Mises theory and Modified Goodman criterion, respectively.

Von Mises Theory:

$$n = \frac{0.577S_y}{\tau_{max}}$$

Modified Goodman criterion:

$$S_m = \frac{(S_y - S_e)S_{ut}}{S_{ut} - S_e}$$

$$S_a = S_y - S_m$$

$$\frac{1}{n} = \frac{\sigma_m}{S_y} + \frac{\sigma_a}{S_y}$$

#### 4.1.1.2 Tire Rod Hook

The tire rod was designed to hold the child's weight, tire and wooden support in the air without fail. Hence the initial material of choice was AISI 1045 Cold Drawn Steel. The stresses experienced by the hook was a combined axial and bending normal stress, and since the

material is ductile, the hook was tested for static and fatigue failure. For static failure, the Von Mises Theory was used, and for fatigue failure, the Modified Goodman criterion was used.

For static loading,

$$F : 543.5 / 2 = 271.75 N$$

$$M: 271.75 * 12.5 = 3396.88 Nmm$$

For fatigue loading,

$$F: (168.75, 271.75)N$$

$$M: (2109.4, 3396.9)Nmm$$

#### **4.1.2 Structure 2 Dome/Calabash**

Due to the complexity of the design of this structure, it was decided that the analysis of this structure would rely solely on Finite Element Analysis.

#### **4.1.3 Structure 3 Slide**

The slide structure has one critical member, the platform where the children's weight will be applied directly. The initial material chosen for the platform was AISI 1015 Cold Drawn Steel. The structure was analysed for static and fatigue failure using the Von Mises theory and the Modified Goodman. Considering the platform is a thin beam, the calculations were based on the fact that the platform would experience bending normal stress. Another assumption made was that using the weight of an average adult at the centre of the platform would provide a reasonable estimate of the platform's performance with younger children spread out at different points. This static load was also the basis for the fatigue failure test.

Static Load,

$$F: 80 * 9.81 = 784.8 N$$

$$M: 784.4 * 1350 = 1.06 * 10^6 Nmm$$

Fatigue Load,

$$F: (0,784.8)N$$

$$M: (0,1.06 * 10^6)Nmm$$

#### **4.1.4 Structure 4 Trotro**

The trotro structure, similarly to the calabash, has a very complex design that was analysed using Finite Element Analysis.

#### **4.2 Numerical**

All structures were analysed using Finite Element Analysis to determine the performance of the structures. The critical areas (areas most likely to experience failure) were tested for static and fatigue failure. SOLIDWORKS was the software used to conduct the FEA on the structures. As defined in the Shigley's Mechanical Engineering Design [5], Finite Element Analysis is the "division of the structure into small, finite, well-designed, elastic sub-structures." This method enables the software to analyse the effects of load on the structure carefully. Aside from the fourth structure (Trotro), the welded parts in the remaining three structures were treated as solids to allow the software to conduct a fatigue analysis. The trotro structure could not be treated as a solid as the software struggled to analyse the bus frame as a solid.

The complete calculations for each of the structures can be found in Appendix A.

## Chapter 5: Results and Discussion

The results of the analyses in the previous chapter are presented and discussed.

### 5.1 Structure 1

Below are the results of the analytical method of analysis of Structure 1:

Table 2.0 Results of Analytical Calculations

Section of the Structure	Static FOS	Fatigue FOS
Teak Wooden Beam	3.47	N/A
AISI 1045 Steel Hook	2.09	1.8
AISI 1015 Steel Beam	4.7	4.02

The calculations for the values above can be found in Appendix A.

Due to limitations in software capability, the original wooden beams used for Structure 1 were replaced with AISI 1015 Cold Drawn steel beams. Each beam measured 80 x 80 x 5 mm. The results of the simulation of the beam's behaviour with maximum load (weight of the child and suspended tire), minimum load (weight of the suspended tire), repeated loading (fatigue test) are shown below.

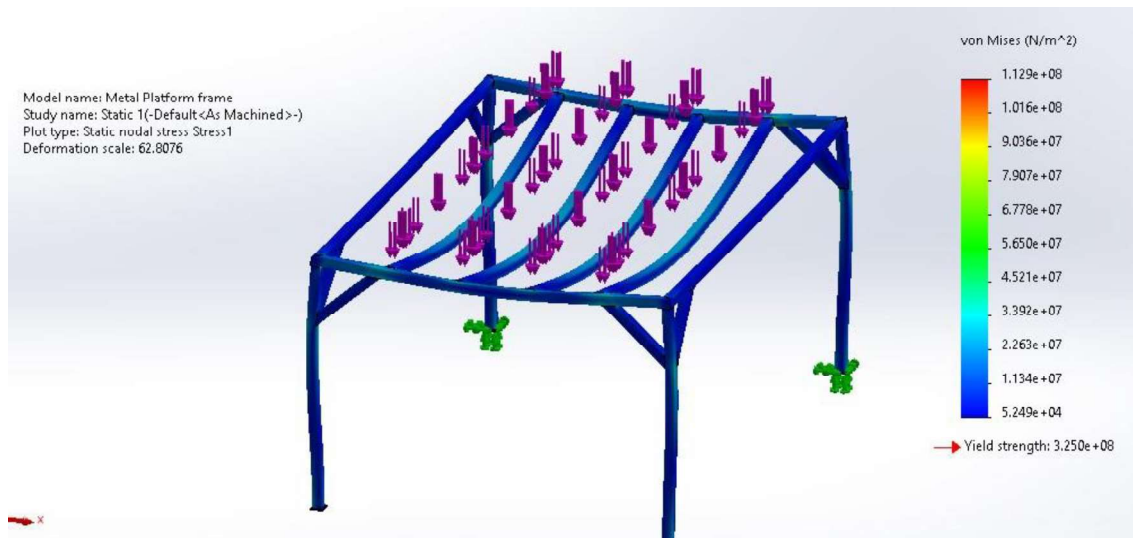

Figure 15 Static Maximum stress on Metal Frame

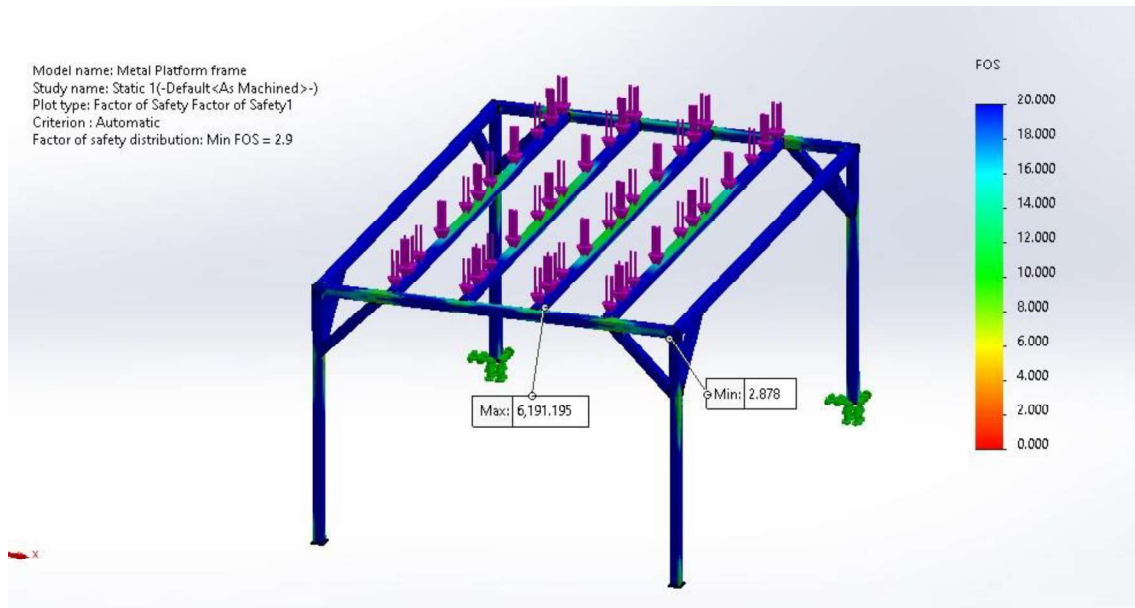

Figure 16 Factor of Safety of Maximum Static load

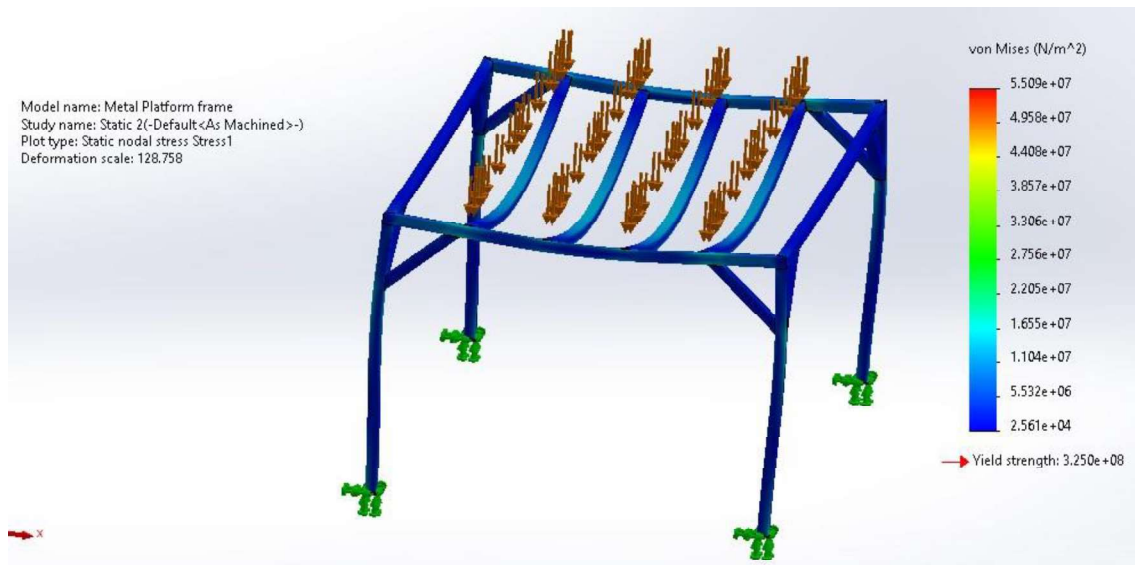

Figure 17 Static Minimum Stress on Metal Frame

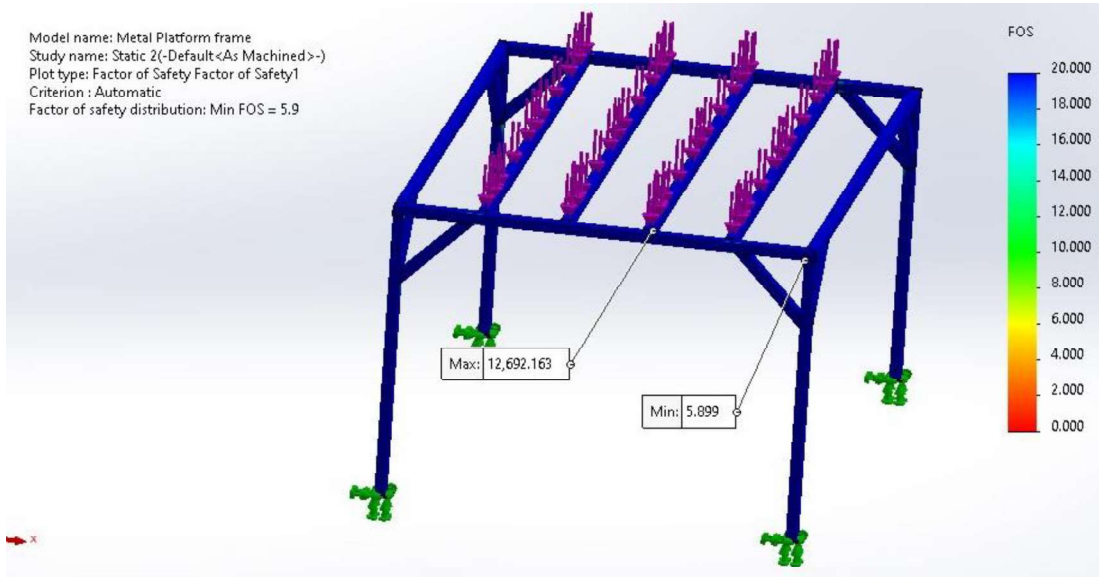

Figure 18 Factor of Safety of Minimum Static load

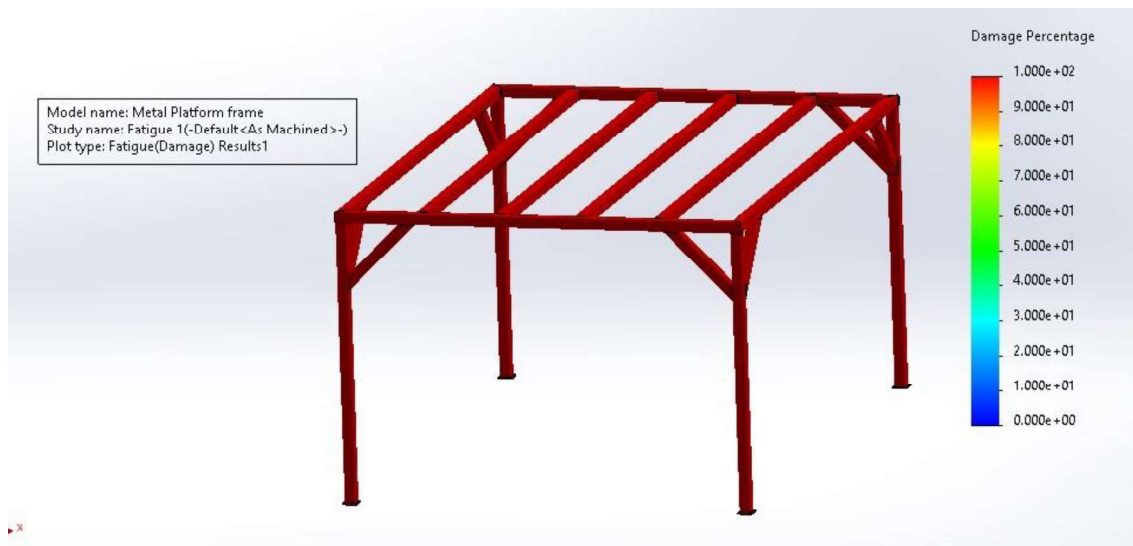

Figure 19 Damage percentage after fatigue analysis

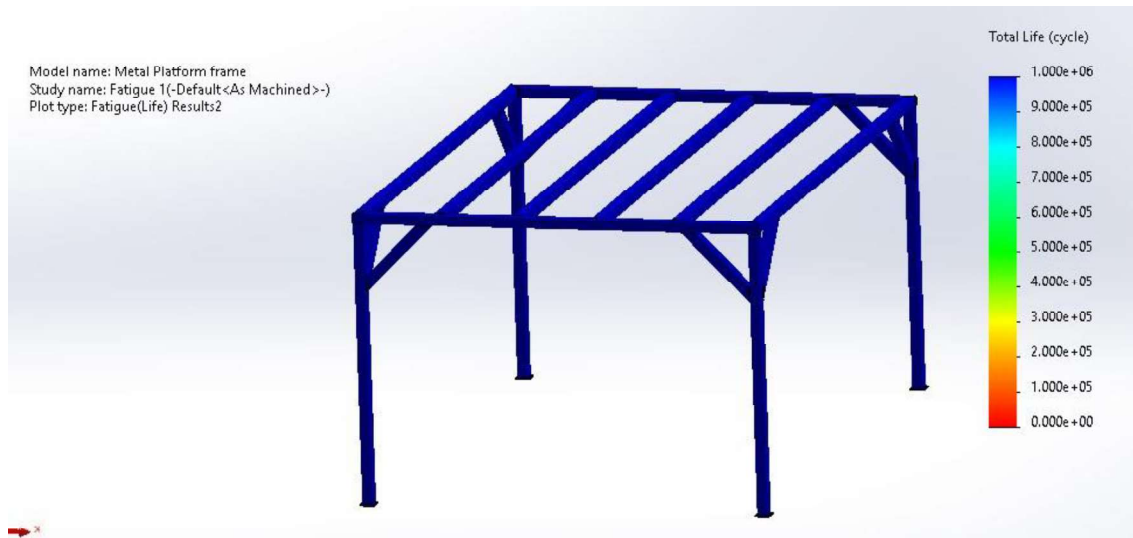

Figure 20 Total life cycle of the structure

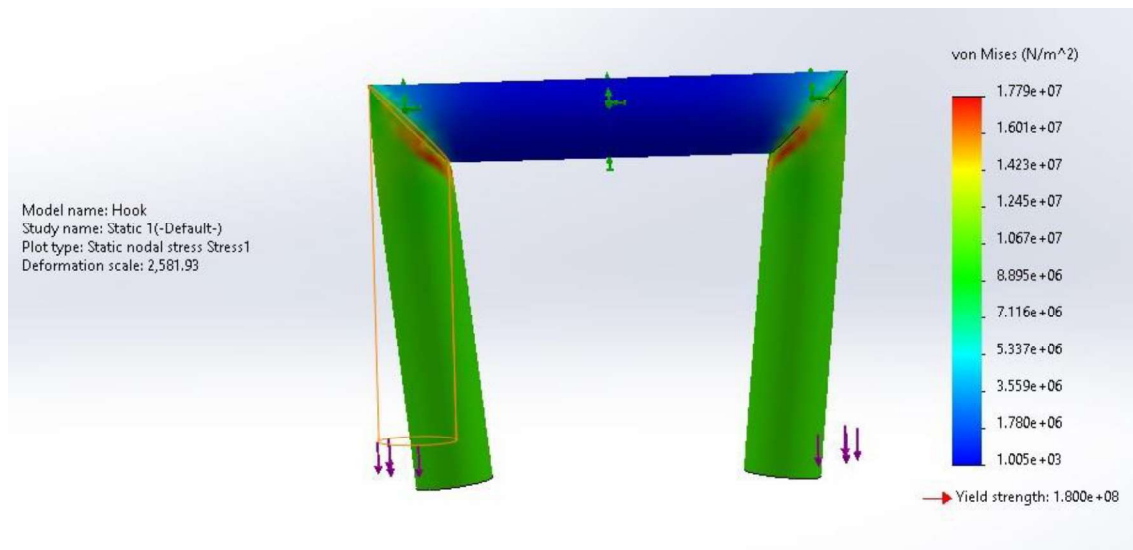
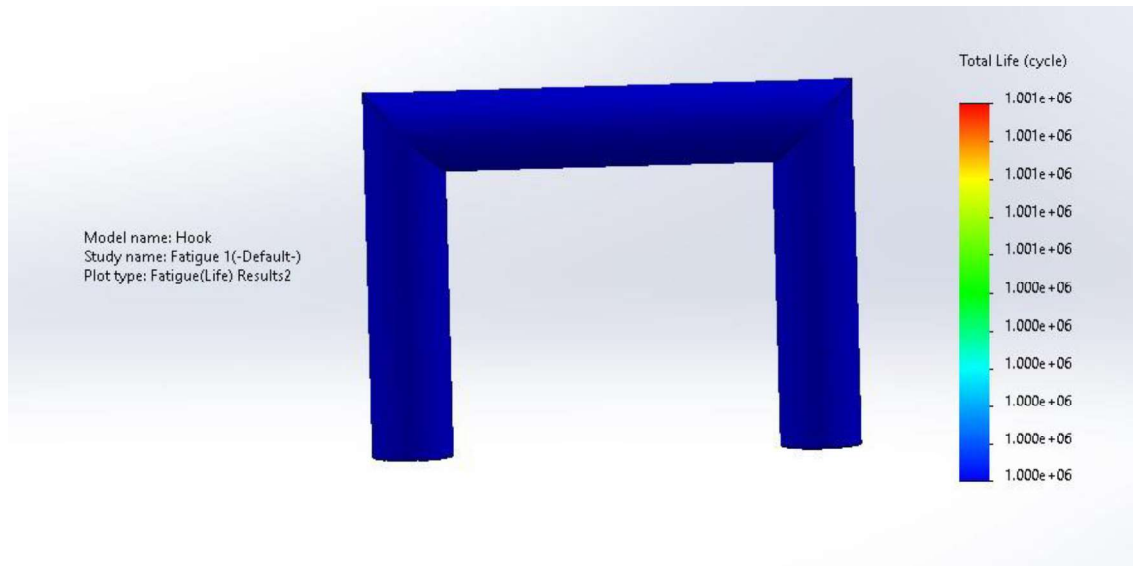

Figure 21 Stress distribution of maximum static load







*Figure 24 Total life cycle of hook*

As shown in the figures above, the lowest factor of safety for the metal frame was 2.9 when the frame was experiencing the maximum static load, and the highest FOS (5.9) was during the minimum load. In both cases, the value was safe enough for static loading. Using those loading values, the FEA found that the stresses generated were too low to cause any significant damage after one million cycles. Hence, the structure was deemed safe.

Regarding the AISI 1045 steel hook, the FEA showed a safety factor that was too large and was clear evidence of over-design; hence the material of the hook was replaced with AISI 1010 steel. The safety factor was reduced to a value of 10 because of this change. Though the value is still higher than preferred, the small dimensions of the hook paired with the absence of a weaker material make this a satisfactory material. The fatigue analysis also shows that the stresses experienced by the hook are too low to cause any significant damage after one million cycles.

## **5.2 Structure 2**

As previously stated, the design of the second structure was too complex to be analysed by hand. Hence, FEA was used to analyse the structure. The initial structure in Figure 12 (AISI

1010 Cold Drawn Steel) gave a factor of safety of approximately 15,000, which was severely over-designed. As a result, the structure was completely redesigned using steel pipes of 33.7 x 4.0 mm (AISI 1010 Cold Drawn Steel).

Assuming the max number of children the structure can support is 24 (6 children per quarter), the Static Load is:

$$F: 21 * 9.81 * 24 = 4944.24 \text{ N}$$

Fatigue Load,

$$F: (0, 4944.24) \text{ N}$$

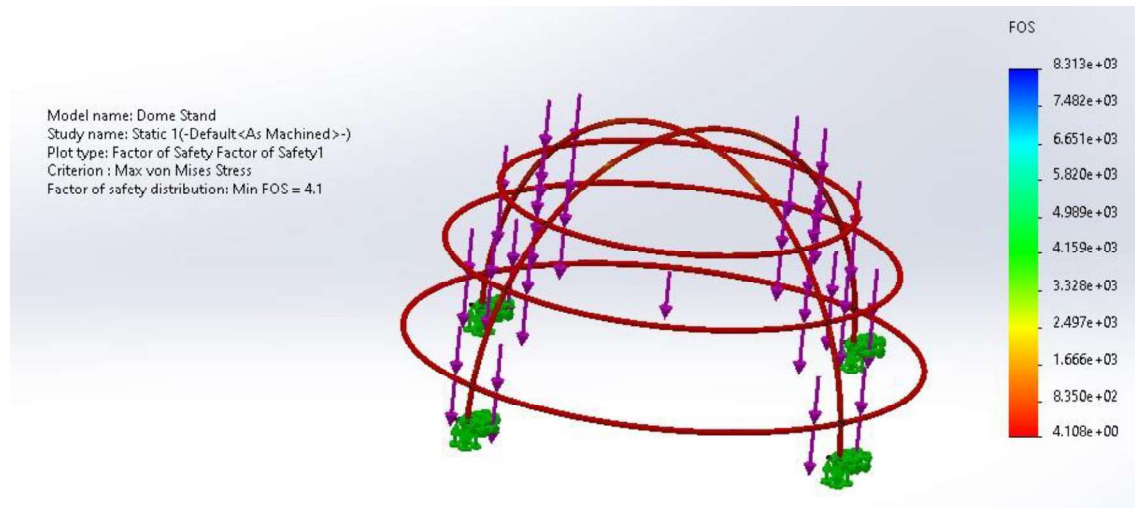

Figure 25 FOS of Static Load

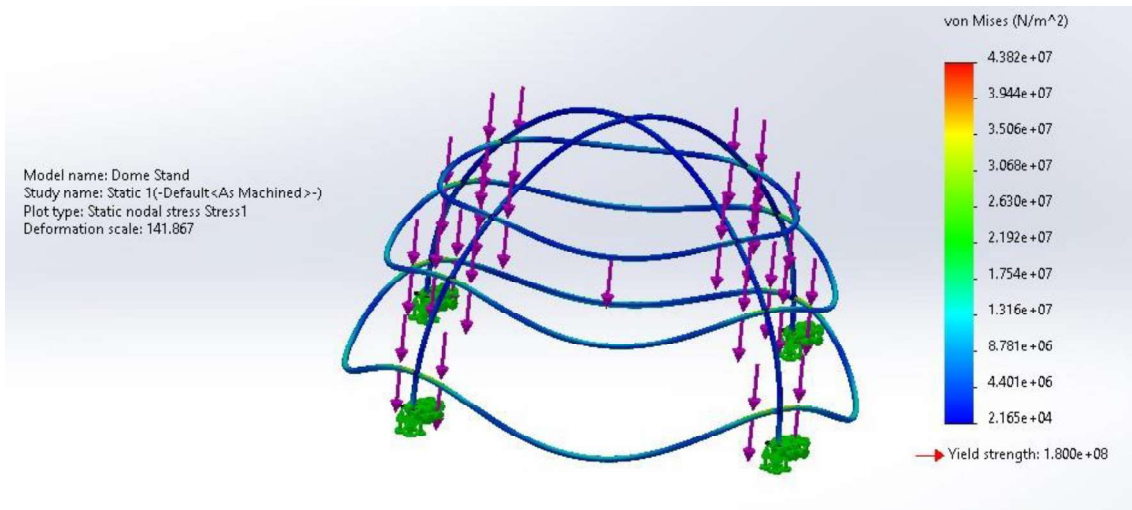

Figure 26 Stress distribution of Static load

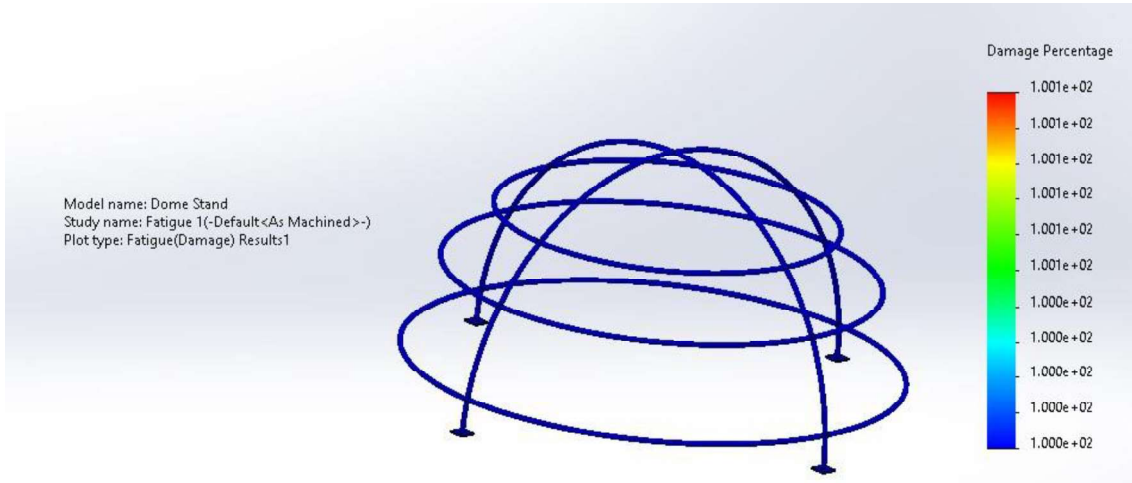

Figure 27 Damage percentage after 1 million cycles

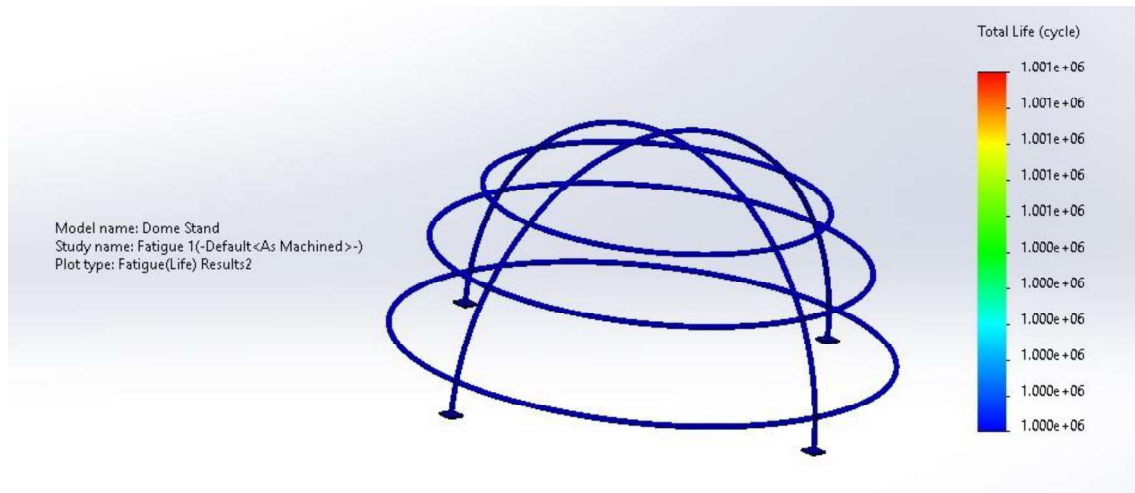

Figure 28 Life cycle after Fatigue test

As shown in figure 25, the FOS of the structure under the maximum load is 4.1, which is satisfactory. The fatigue analysis reveals that the structure does not experience any stress that would cause any significant damage after 1 million loading cycles.

### 5.3 Structure 3

Table 3.0 Hand calculated factors of safety in Structure 3

Section of the Structure	Static FOS	Fatigue FOS
Platform (AISI 1015)	15.6	8.3

The calculations for the values above can be found in Appendix A.

The platform where the children would stand was assumed to be the critical location, and the calculated factors of safety are shown in Table 3.

For the finite element analysis, the platform was loaded with the weight of 12 children. This load was chosen based on the assumption that the maximum number of children on the platform at any point would be 12.

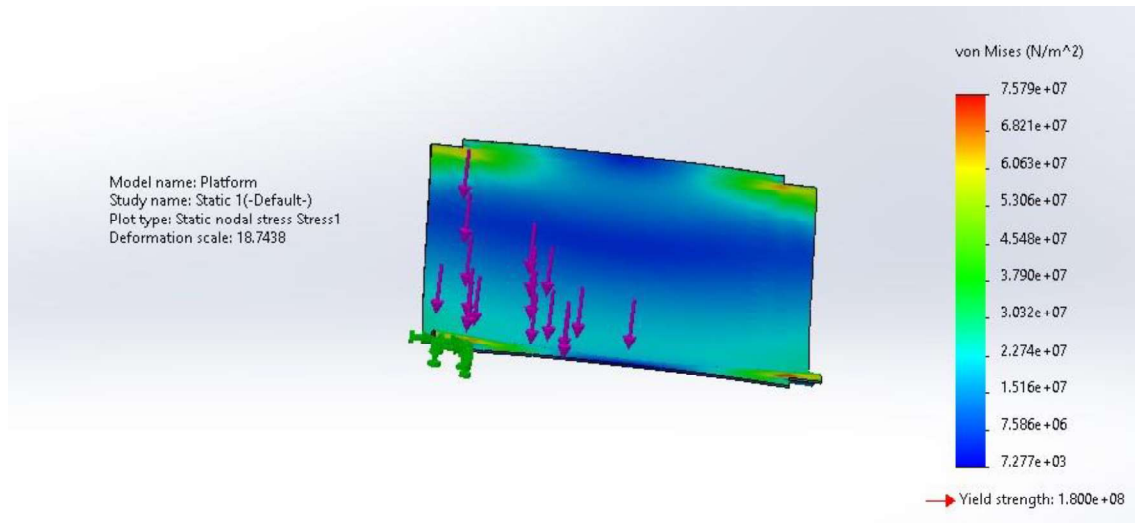

Figure 29 Stress Distribution on the platform during static load

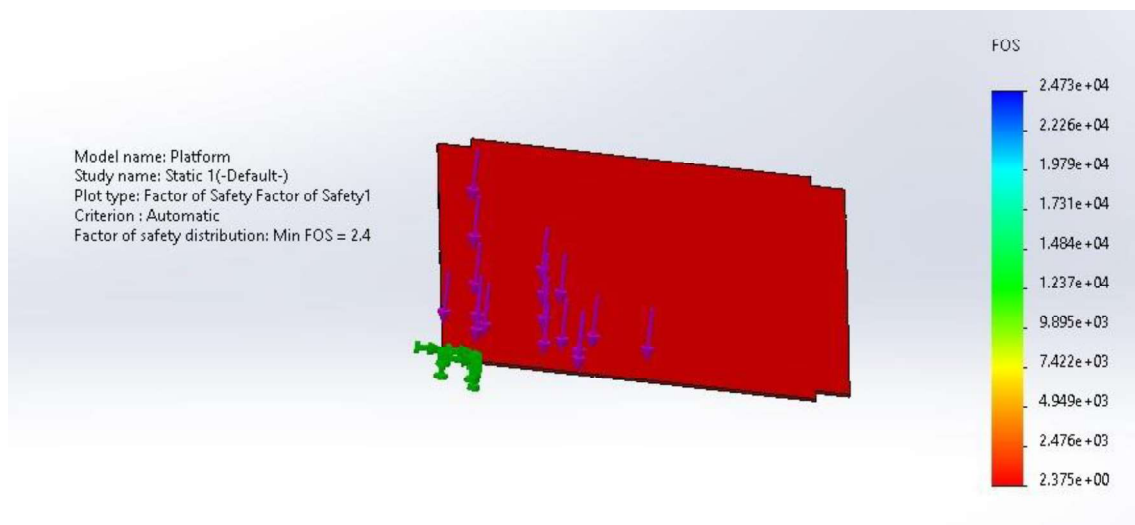

Figure 30 Factor of Safety of the platform during static load

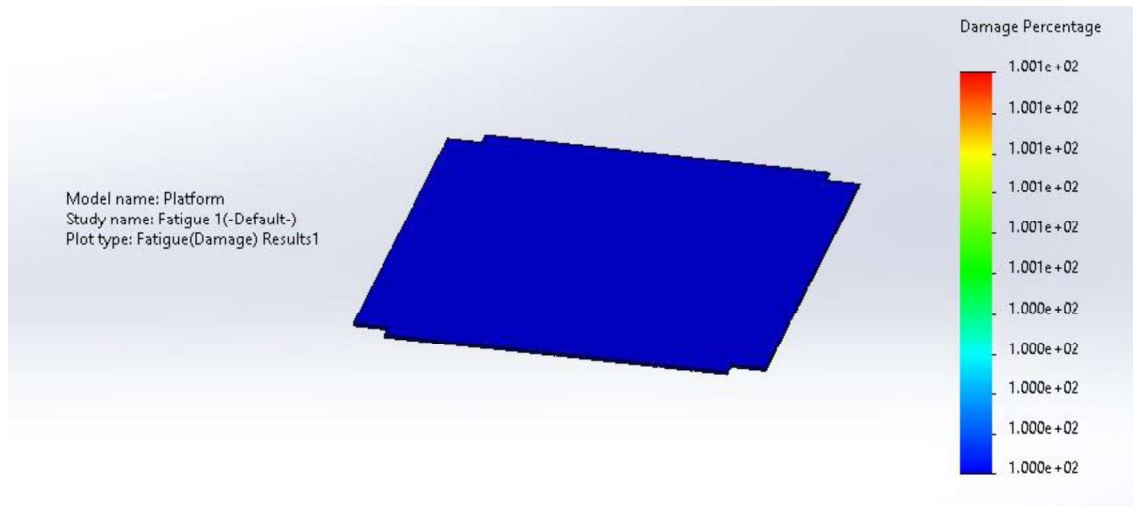

Figure 31 Damage percentage on the platform after 1 million cycles

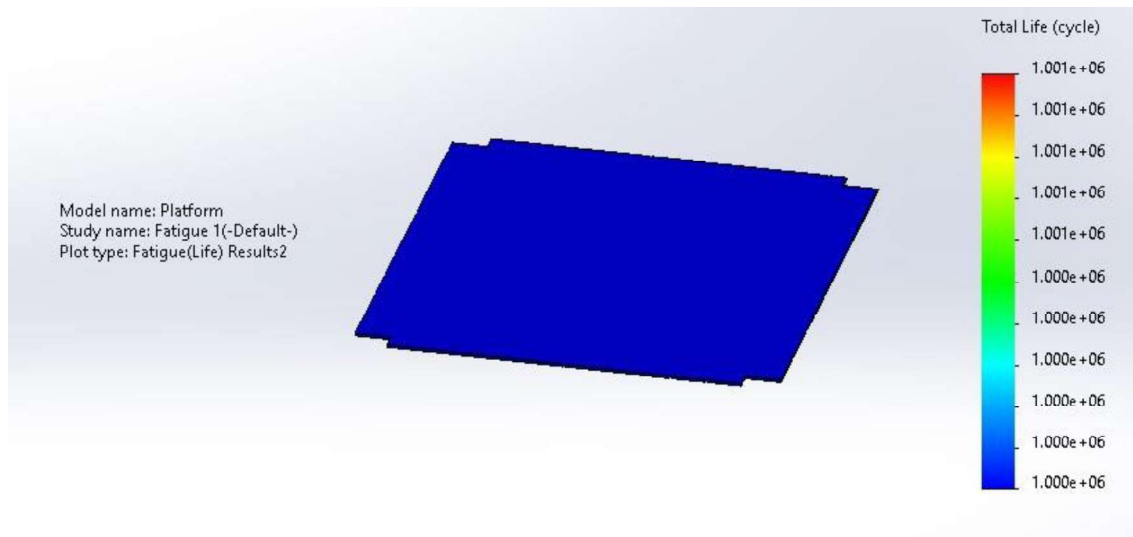

Figure 32 Life cycle of the platform after fatigue analysis

As shown in the figures above, the platform was deemed safe based on the results of the FEA. The static loading gave a safety factor of 2.1, and the stresses generated were too low to cause any significant damage after one million cycles.

#### 5.4 Structure 4

Most of the load experienced by the bus frame would be on the base where the children would be seated or standing. Due to the structure being made entirely of steel beams welded together,

the software could only analyse static loads. Like the platform on the slide structure, the maximum number of children assumed to be within the bus was 12.

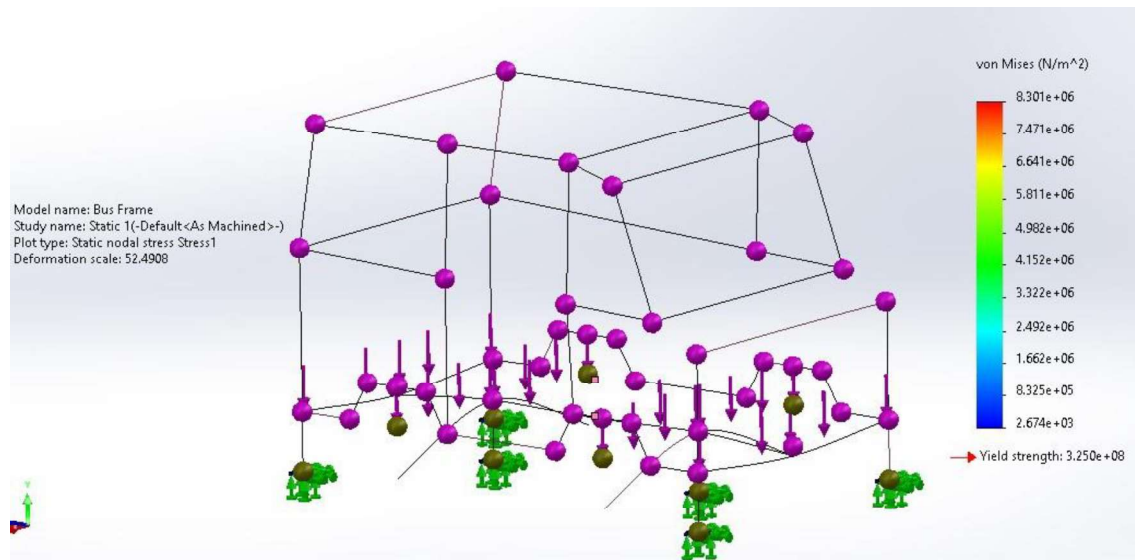

Figure 33 Stress Distribution across the Bus frame under static load

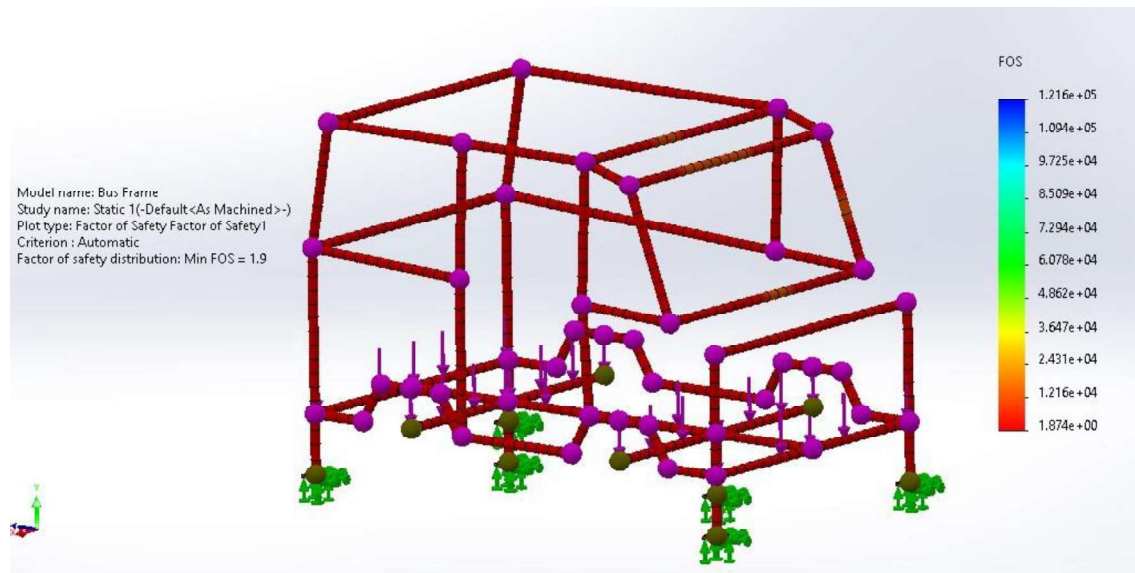

Figure 34 FOS of the bus frame under static load

As a result of the static analysis, it was found that the FOS was 1.9 under static load, which was deemed safe for use.

## **Chapter 6: Conclusion and Future Works**

This chapter concludes the overall project. The constraints, difficulties and future works are elaborated here.

In conclusion, the project's objectives were met, the structures designed were analysed and proved to be safe. Unfortunately, there were a few constraints and challenges that were experienced during this project. Firstly, the initial designs of this project incorporated more wood in the structures as wood is a more affordable alternative to steel. Unfortunately, due to limitations in the Solidworks software's ability to analyse wooden members, significant changes were made to the designs of the structures to replace as much wood as possible with steel. This change would increase the cost of fabrication significantly. Secondly, more analyses should be conducted, such as a vibrational analysis and a temperature analysis. These analyses were not performed as a result of time and expertise constraints.



## References

- [1] J. Soler-Adillon and N. Parés, 'Interactive Slide: An Interactive Playground to Promote Physical Activity and Socialisation of Children', in *CHI '09 Extended Abstracts on Human Factors in Computing Systems*, New York, NY, USA, 2009, pp. 2407–2416, doi: 10.1145/1520340.1520343.
- [2] C. Norton, J. Nixon, and J. R. Sibert, 'Playground injuries to children', *Arch. Dis. Child.*, vol. 89, no. 2, pp. 103–108, Feb. 2004, doi: 10.1136/adc.2002.013045.
- [3] A.-M. Parrish, H. Yeatman, D. Iverson, and K. Russell, 'Using interviews and peer pairs to better understand how school environments affect young children's playground physical activity levels: a qualitative study', *Health Educ. Res.*, vol. 27, no. 2, pp. 269–280, Apr. 2012, doi: 10.1093/her/cyr049.
- [4] H. Little and D. Eager, 'Risk, challenge and safety: implications for play quality and playground design', *Eur. Early Child. Educ. Res. J.*, vol. 18, no. 4, pp. 497–513, Dec. 2010, doi: 10.1080/1350293X.2010.525949.
- [5] K. Nisbett and R. Budynas, *Shigley's Mechanical Engineering Design, 10th Edition*, 10th ed. McGraw-Hill Education, 2015.

## Appendix A

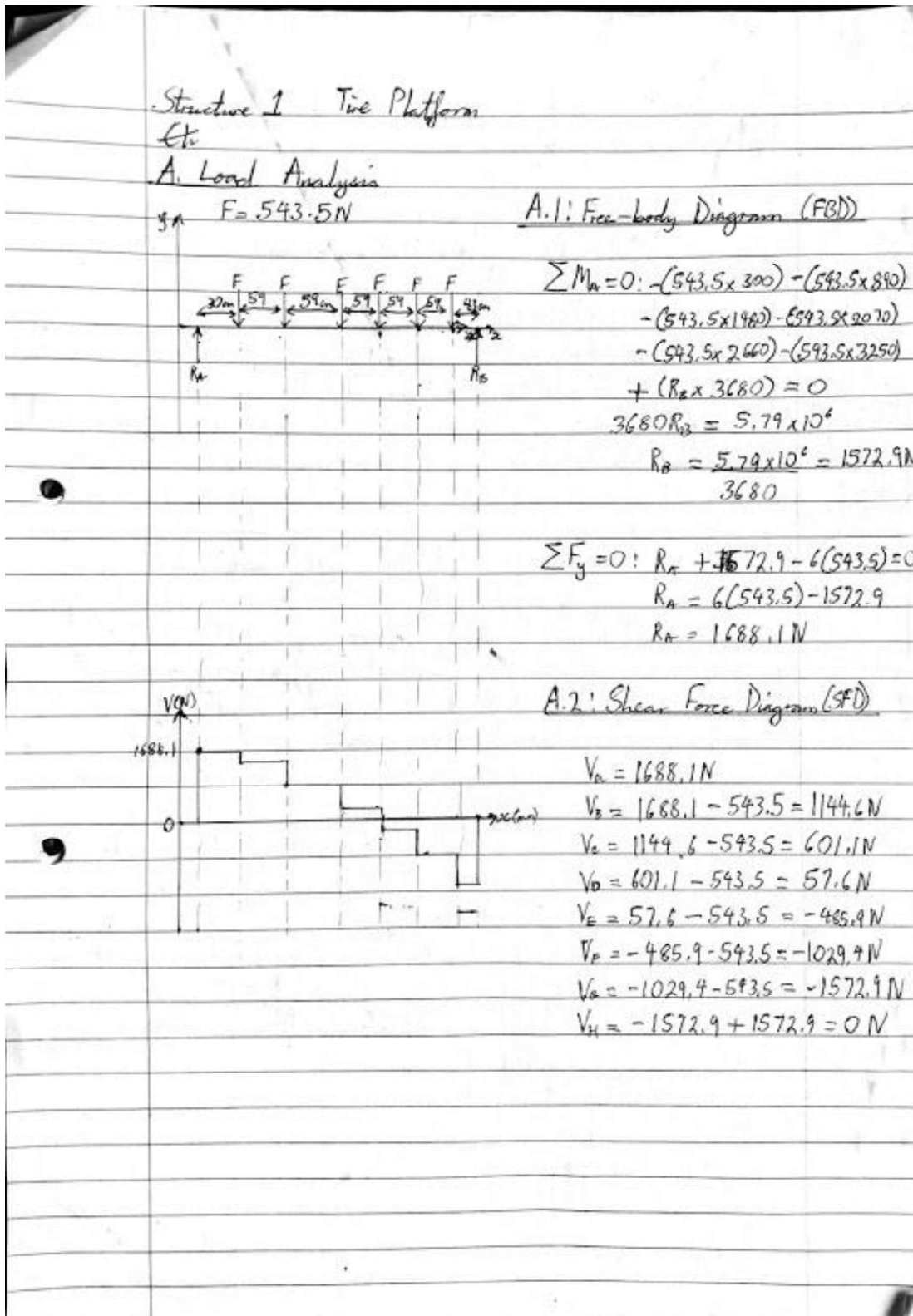
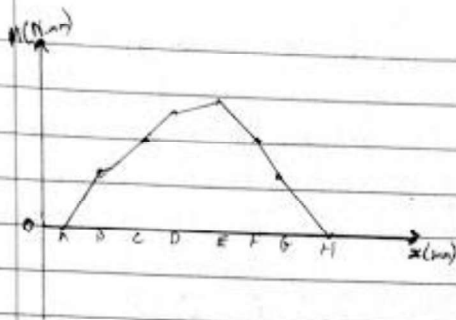

Figure A 1 Static Load Analysis on a single wooden beam from Structure 1



### A.3 Bending Moment Diagram (BMD)

$$M_A = 1688,1 \times 0 = 0 \text{ Nm}$$

$$M_B = 1688,1 \times 300 = 50,6 \times 10^4 \text{ Nm}$$

$$M_C = 50,6 \times 10^4 + 1144,6 \times 590 = 1,18 \times 10^6 \text{ Nm}$$

$$M_D = 1,18 \times 10^6 + 601,1 \times 590 = 1,59 \times 10^6 \text{ Nm}$$

$$M_E = 1,59 \times 10^6 + 57,6 \times 590 = 1,57 \times 10^6 \text{ Nm}$$

$$M_F = 1,57 \times 10^6 - 485,9 \times 590 = 1,28 \times 10^6 \text{ Nm}$$

$$M_G = 1,28 \times 10^6 - 1029,4 \times 590 = 6,76 \times 10^5 \text{ Nm}$$

$$M_H = 6,76 \times 10^5 - 1572,9 \times 430 = 0 \text{ Nm}$$

## B. Stress Analysis

### B.1. Applied Stresses

Critical Point at E

#### B.1.1. Normal Stress

Bending Normal Stress

$$\sigma_x = \frac{6M}{bh^2} = \frac{6 \times 1,57 \times 10^6}{200^3} = 1,18 \text{ MPa}$$

#### B.1.2. Shear Stress

Transverse Shear Stress

$$\tau_v = \frac{3V}{2A} = \frac{3 \times 485,9}{2(200)^2} = -0,018 \text{ MPa}$$

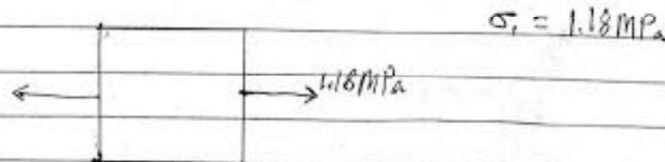

Figure A 2 Stress Analysis on wooden beam from Structure 1

C. Material

Teak wood,  $S_{ut} = 4.10 \text{ MPa}$ , Failure type: Brittle

D. Design Equation and Solution

Using MMST,  $n = \frac{S_{ut}}{\sigma_1} = \frac{4.10}{1.18} = 3.47$

Figure A 3 Material Selection and Design Solution

# New Structure 1 Metal Frame (Failure Analysis)

## A. Load Analysis A Load Analysis

$F(2025, 3)$   
 $F = 337.5 \text{ N}$

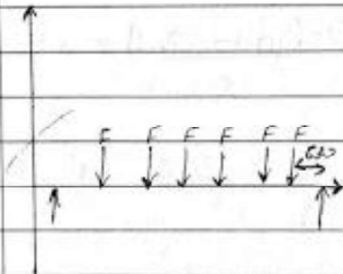

### FBD

$$\begin{aligned} \sum M_A = 0: & -(337.5 \times 300) - (337.5 \times 590) \\ & - (337.5 \times 1480) - (337.5 \times 2070) \\ & - (337.5 \times 2660) - (337.5 \times 3250) \\ & + R_H \times 3880 = 0 \\ 3880 R_H & = 3.59 \times 10^6 \\ R_H & = \frac{3.59 \times 10^6}{3880} = 926.4 \text{ N} \end{aligned}$$

$$\begin{aligned} \sum F_y = 0: & R_A + 926.4 - 6(337.5) = 0 \\ R_A & = 1098.6 \text{ N} \end{aligned}$$

### SFD

$$\begin{aligned} V_A & = 1098.6 \text{ N} \\ V_B & = 1098.6 - 337.5 = 761.1 \\ V_C & = 761.1 - 337.5 = 423.6 \\ V_D & = 423.6 - 337.5 = 86.1 \\ V_E & = 86.1 - 337.5 = -251.4 \\ V_F & = -251.4 - 337.5 = -588.9 \\ V_G & = -588.9 - 337.5 = -926.4 \\ V_H & = 0 \end{aligned}$$

### BMD

$$\begin{aligned} M_A & = 0 \\ M_B & = 1098.6 \times 300 = 0.33 \times 10^6 \text{ Nm} \\ M_C & = 0.33 \times 10^6 + 761.1 \times 590 = 0.76 \times 10^6 \text{ Nm} \\ M_D & = 0.76 \times 10^6 + 423.6 \times 590 = 1.03 \times 10^6 \text{ Nm} \\ M_E & = 1.03 \times 10^6 + 86.1 \times 590 = 1.08 \times 10^6 \text{ Nm} \\ M_F & = 1.08 \times 10^6 - 251.4 \times 590 = 0.93 \times 10^6 \text{ Nm} \\ M_G & = 0.93 \times 10^6 - 588.9 \times 590 = 0.98 \times 10^6 \text{ Nm} \\ M_H & = 0.98 \times 10^6 - 926.4 \times 630 = 0 \text{ Nm} \end{aligned}$$

### BMD

Figure A 4 Load Analysis on new Metal Beam for structure 1

## New Structure 1 Metal Frame (Static Analysis)

### A. Load Analysis

Same as previous structure

### B. Stress Analysis

Critical Point at E

#### B.1.1 Normal Stress

Bending Normal Stress  $M = 1.57 \times 10^6$

$$\sigma_{\max} = \frac{6M}{bh^2} = \frac{6 \times 1.57 \times 10^6}{(68^2 - 70^2) 80} = 78.5 \text{ MPa}$$

#### C. Material

AISI 1015 CD Steel,  $S_y = 320 \text{ MPa}$ , Failure type: Ductile

#### D. Design Equation and Solution

$$\text{Using von Mises Theory, } n = \frac{S_y}{\sigma_{\max}} \cdot 0.57753 = \frac{0.577 \times 320}{78.5} \\ = 4.7$$

Figure A 5 Stress Analysis, Material Selection and Design Solution for the metal beam



## Non-Structure 1 Metal Frame (Failure Analysis)

A. Load Analysis  $M(1.08 \times 10^6, 1.57 \times 10^6) \text{ Nmm}$

$$M_m = \frac{(1.08 + 1.57) \times 10^6}{2} = 1.325 \times 10^6 \text{ Nmm}$$

$$M_a = \frac{(1.57 - 1.08) \times 10^6}{2} = 0.245 \times 10^6 \text{ Nmm}$$

## B. Stress Analysis

$$\tau_{sm} = \frac{6 \times 1.325 \times 10^6}{(80^2 - 70^2) 80} = 66.25 \text{ MPa}$$

$$\sigma_a = \frac{6 \times 0.245 \times 10^6}{(80^2 - 70^2) 80} = 12.25 \text{ MPa}$$

## C. Material Properties

AISI 1015 CD Steel,  $S_{ut} = 390 \text{ MPa}$ ,  $S_{yc} = 320 \text{ MPa}$

$$S_e' = 0.5 \times 390 = 195 \text{ MPa}$$

$$d_e = 0.808 (80^2 - 70^2)^{1/4}$$

$$k_a = 4.51 (390)^{-0.265} = 0.928$$

$$= 31.29$$

$$k_b = 1.24 (31.29)^{-0.107} = 0.858$$

$$k_c = k_d = k_e = k_f = 1$$

$$k_H = k$$

$$S_e = 195 \times 0.928 \times 0.858 = 155.3 \text{ MPa}$$

Figure A 6 Fatigue Load Analysis, Stress Analysis and Material Properties for the metal beam in Structure 1

D. Design Equation and Solution  
PC(66.25, 12.25)

$$S_m = \frac{(S_u - S_e) S_{ur}}{S_u - S_e} = \frac{(320 - 155.3) 390}{390 - 155.3} = 273.681$$

$$S_e = S_y - S_m = 320 - 273.681 = 46.32$$

$$r_e = \frac{46.32}{273.681} = 0.169, \quad r_u = \frac{S_u}{S_n} = \frac{12.25}{66.25} = 0.185$$

$r_u > r_e$  Fatigue Failure

$$\frac{1}{n} = \frac{66.25}{390} + \frac{12.25}{155.3}$$

$$\frac{1}{n} = 0.249$$

$$n = 4.02$$

Figure A 7 Design Solution for the metal beam



## Structure 1 contd. Static Analysis Hook (Tire)

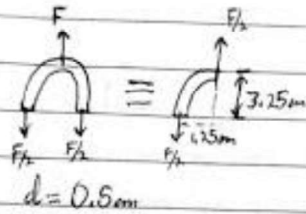

### A. Load Analysis

$$F = 543.5 \text{ N} \div 2 = 271.75 \text{ N}$$

$$M = 271.75 \times 12.5 \\ = 3396.88 \text{ Nmm}$$

### B. Stress Analysis

#### B.1.1: Normal Stress

##### Combined Axial and Bending Normal Stress

$$\sigma = \frac{F}{A} + \frac{32M}{\pi d^3} = \frac{271.75}{\pi \times 5^2 \times 0.25} + \frac{32 \times 3396.88}{\pi \times 5^3}$$

$$= 13.84 + 276.8$$

$$= 290.6 \text{ MPa}$$

#### B.1.2: Shear Stress

##### Single Shear

$$\tau = \frac{V}{A} = \frac{271.75}{\pi \times 5^2 \times 0.25} = 13.8 \text{ MPa}$$

Figure A 8 Static Load and Stress Analysis on the metal hook for the tire rod in Structure 1

### ~~B.2~~ B.2: Stress Element

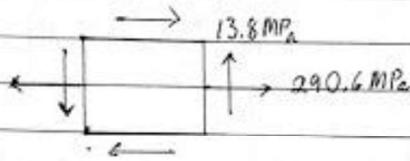

### B.3 Design Stresses

$$\sigma_{av} = 290.6 \text{ MPa} \Rightarrow \sigma_{avg} = \frac{290.6}{2} = 145.3 \text{ MPa}$$
$$\tau_{xy} = 13.8 \text{ MPa}$$

$$C(145.3, 0) \quad X(290.6, 13.8)$$

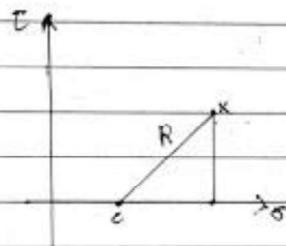

$$|290.6 - 145.3| = 145.3$$

$$R = \sqrt{145.3^2 + 13.8^2} = 146 \text{ MPa}$$

$$\sigma_1 = \sigma_{avg} + R = 291.3 \text{ MPa}$$

$$\sigma_2 = \sigma_{avg} - R = -0.7 \text{ MPa}$$

$$\sigma_3 = 0 \text{ MPa}$$

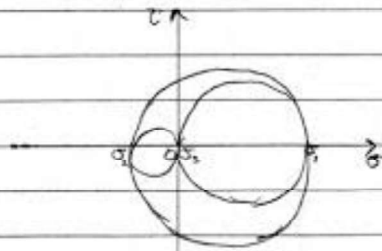

$R$  is the largest radius.

$$\therefore R = \tau_{max}$$

$$\tau_{max} = 146 \text{ MPa}$$

Figure A 9 Continuation of Stress Analysis

C. Material

AISI 1045 CD steel, Failure type: Ductile

$$S_y = 530 \text{ MPa}$$

D. Design Equation and Solution

Using Von Mises Theory,  $n = \frac{2.577 S_y}{T_{max}}$

$$= \frac{2.577 \times 530}{140} = 2.09$$

Figure A 10 Material Selection and Design Solution

## Structure 1 Fatigue Analysis $\leftarrow$ Hook (Tread)

### A. Load Analysis

$$F(168.75, 271.75)N \quad M(2109.4, 3396.9)N_{mm}$$

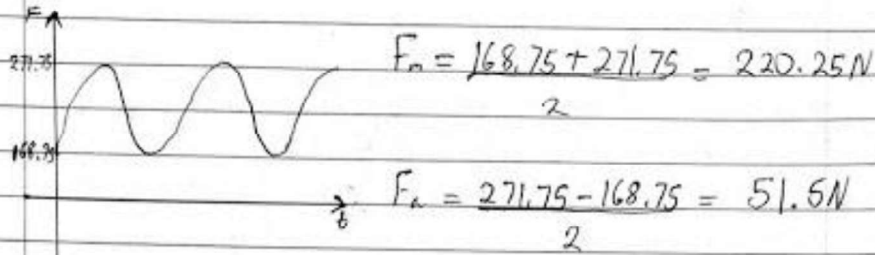

$$\rightarrow M_m = \frac{3396.9 + 2109.4}{2} = 2753.15 N_{mm}$$

$$M_a = \frac{3396.9 - 2109.4}{2} = 643.75 N_{mm}$$

### B. Stress Analysis

$$\sigma_m = \frac{220.25}{\pi \times 5^3 \times 0.25} + \frac{32 \times 2753.15}{\pi \times 5^3} = 11.22 + 224.35 = 235.6 MPa$$

$$\sigma_a = \frac{51.5}{\pi \times 5^3 \times 0.25} + \frac{32 \times 643.75}{\pi \times 5^3} = 2.62 + 52.46 = 55.1 MPa$$

### C. Material Properties

AISI 1045 Steel, Cold Drawn:  $S_{ut} = 630 MPa$ ,  $S_{yf} = 530 MPa$

Figure A 11 Fatigue Load and Stress Analysis, and Material Selection

$$S'_e = 0.5 \times 630 = 315 \text{ MPa}$$

$$K_a = K_b = K_c = K_d = K_e = K_f = 1$$

$$S_e = 315 \text{ MPa}$$

D. Design Equation and Solution

P(235.6, 55.1)

$$S_m = \frac{(S_y - S_e) S_w}{S_{ut} - S_e} = \frac{(530 - 315) 630}{630 - 315} = 430$$

$$S_n = S_y - S_m = 530 - 430 = 100$$

$$r_s = \frac{S_n}{S_m} = \frac{100}{430}, \quad r_t = \frac{\sigma_n}{\sigma_m} = \frac{55.1}{235.6}$$

$$r_c = 0.233, \quad r_e = 0.234$$

$r_s > r_c$ . Failure will be by Fatigue

$$\frac{1}{n} = \frac{235.6}{630} + \frac{55.1}{315}$$

$$\frac{1}{n} = 0.55$$

$$n = \frac{1}{0.55} = 1.8$$

Figure A 12 Design Solution for Fatigue Analysis



### Structure 3 Platform Analysis (Static)

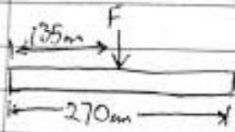

#### A. Load Analysis

$$F = 80 \times 9.81 = 784.8 \text{ N}$$

$$M = 784.8 \times 1350$$

$$= 1.06 \text{ Nm}$$

#### B. Stress Analysis

Bending Normal Stress  $\tau_{max} = \frac{23.6}{2} = 11.8$

$$\sigma_x = \frac{GM}{bb^2} = \frac{6 \times 1.06 \times 10^4}{15^2 \times 1200}$$

$$= 23.6 \text{ MPa}$$

#### C. Material

AISI 1015 CD Steel, Failure Type: Ductile

$$S_y : 320 \text{ MPa}$$

#### D. Design Equation and Solution

$$\text{Von Mises, } n = \frac{0.577 \times 320}{11.8} = 15.6$$

Figure A 13 Structure 3 Platform Static Load Analysis, Stress Analysis, Material Selection and Design Solution

## Structure 3 Platform Analysis (Fatigue)

### 1. Load Analysis

$$F(0, 784.8) \text{ N} \quad M(0, 1.06 \times 10^6) \text{ Nmm}$$

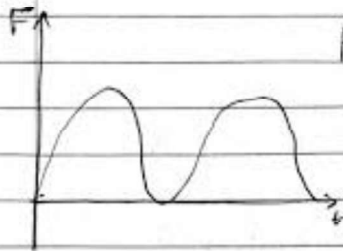

$$F_n = F_m = \frac{784.8}{2} = 392.4 \text{ N}$$

$$M_n = M_m = \frac{1.06 \times 10^6}{2} = 5.3 \times 10^5 \text{ Nmm}$$

### 2. Stress Analysis

$$\sigma_n = \sigma_m = \frac{6 \times 5.3 \times 10^5}{15^2 \times 1200} = 11.8 \text{ MPa}$$

### 3. Material

AISI 1015 CD Steel:  $S_{ut} = 390 \text{ MPa}$   $S_{yc} = 320 \text{ MPa}$

$$S_e = 0.5 \times 390 = 195 \text{ MPa}$$

$$k_a = 4.51(310)^{-0.265} = 0.928$$

$$d_e = 0.808(15 \times 1200)^{1/2} = 108.4$$

$$k_b = 1.51(108.4)^{-0.157} = 0.724$$

$$k_c = 1 = k_d = k_e = k_f$$

$$S_e = 131.02 \text{ MPa}$$

Figure A 14 Platform Fatigue Load and Stress Analysis, and Material Properties

D. Design Equations and Solutions  
P(11.8, 11.8)

$$S_m = \frac{(S_y - S_e) S_{ut}}{S_{ut} - S_e} = \frac{(320 - 131.02) 390}{390 - 131.02} = 284.61$$

$$S_a = S_y - S_m = 320 - 284.6 = 35.41$$

$$r_a = \frac{35.41}{284.6}, \quad r_c = 1$$

$$r_c = 0.124$$

$r_a > r_c$   $\therefore$  Failure will be by Fatigue

$$\frac{1}{n} = \frac{11.8}{390} + \frac{11.8}{131.02}$$

$$\frac{1}{n} = 0.12$$

$$n = 8.3$$

Figure A 15 Design Solution for Fatigue Failure analysis



## Appendix B

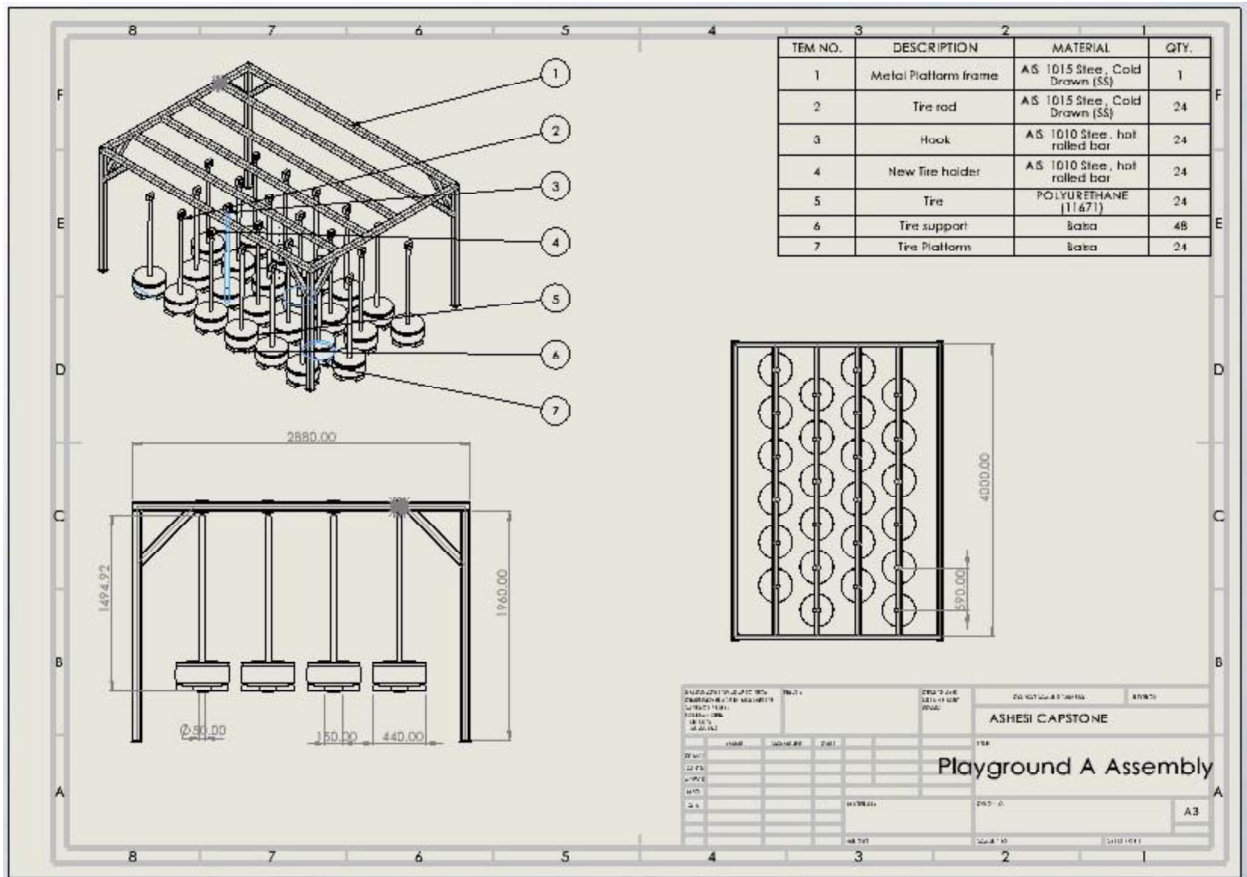

*Figure B 1 Structure 1 Assembly Drawing and dimensions.*

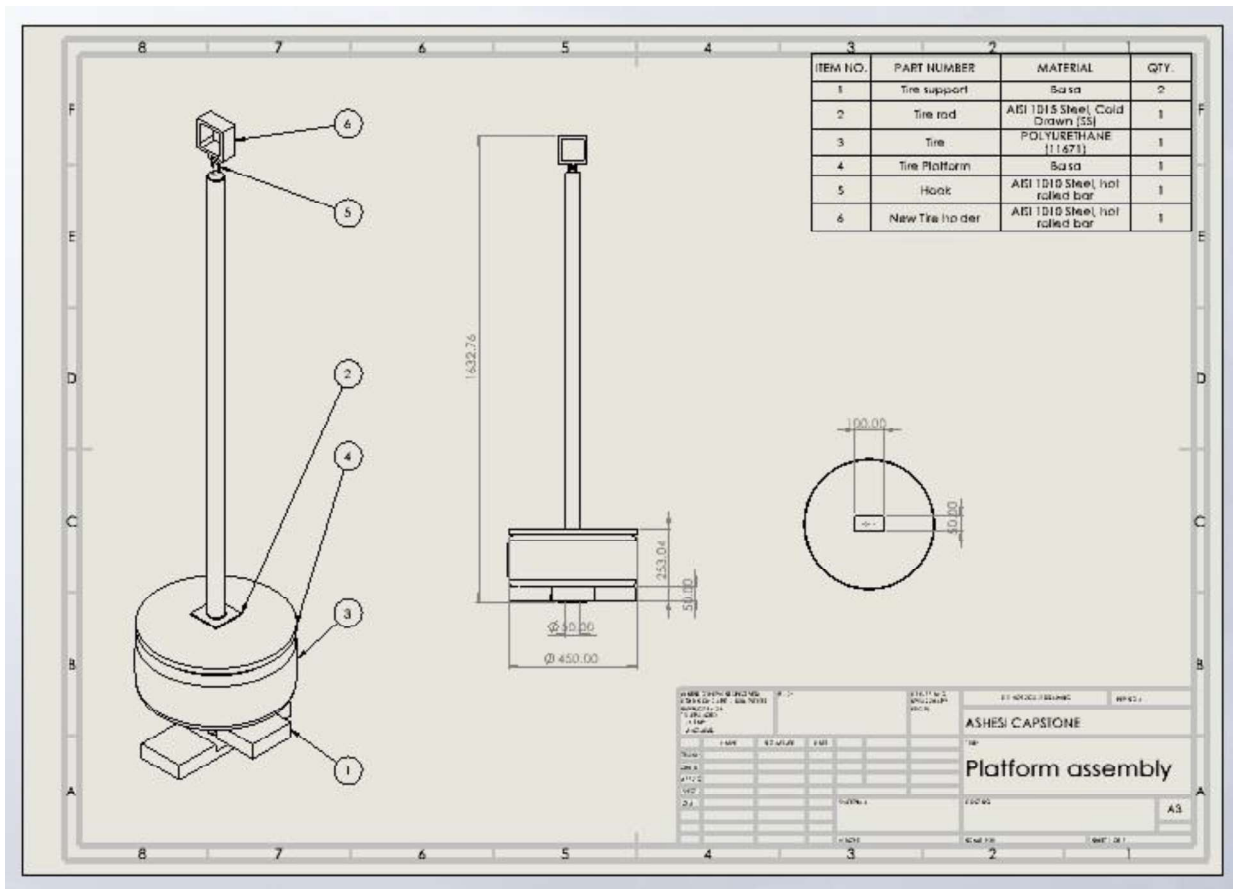

Figure B 2 Tire platform Assembly Drawing and dimensions

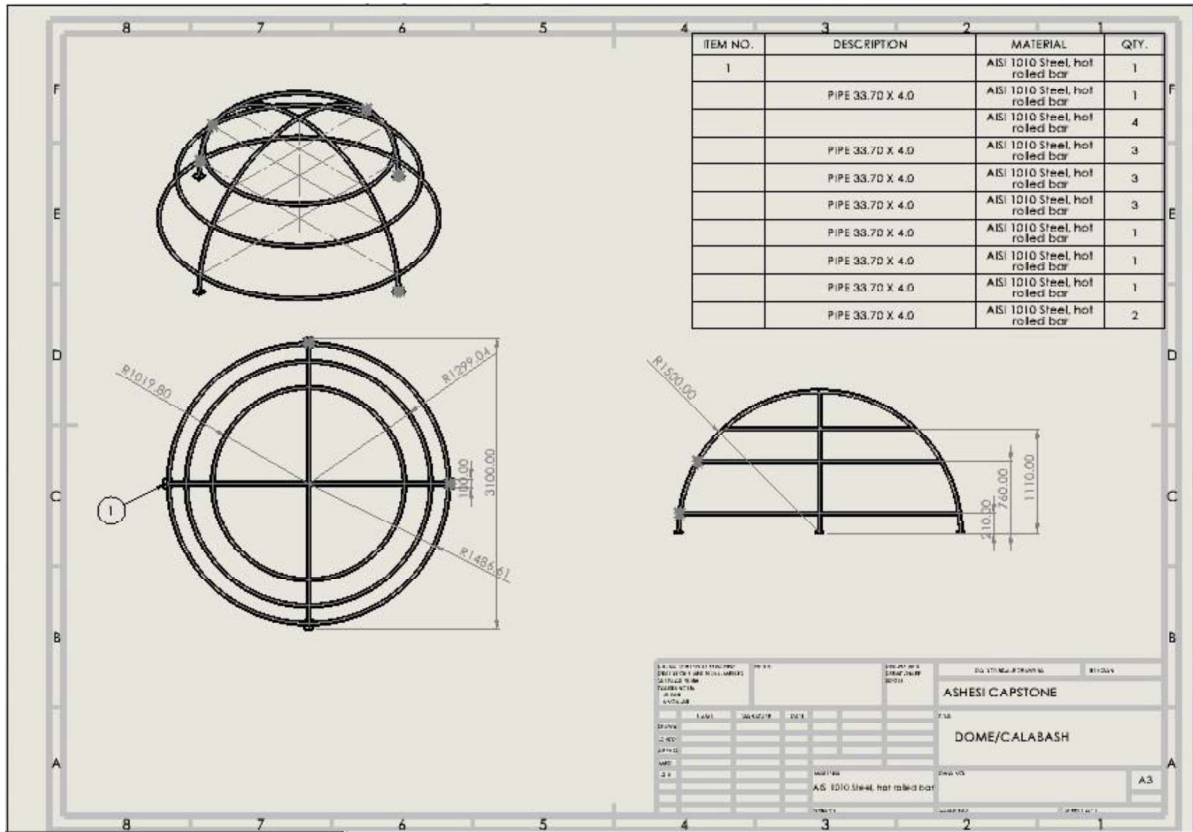

Figure B 3 Structure 2 Part Drawing and dimensions

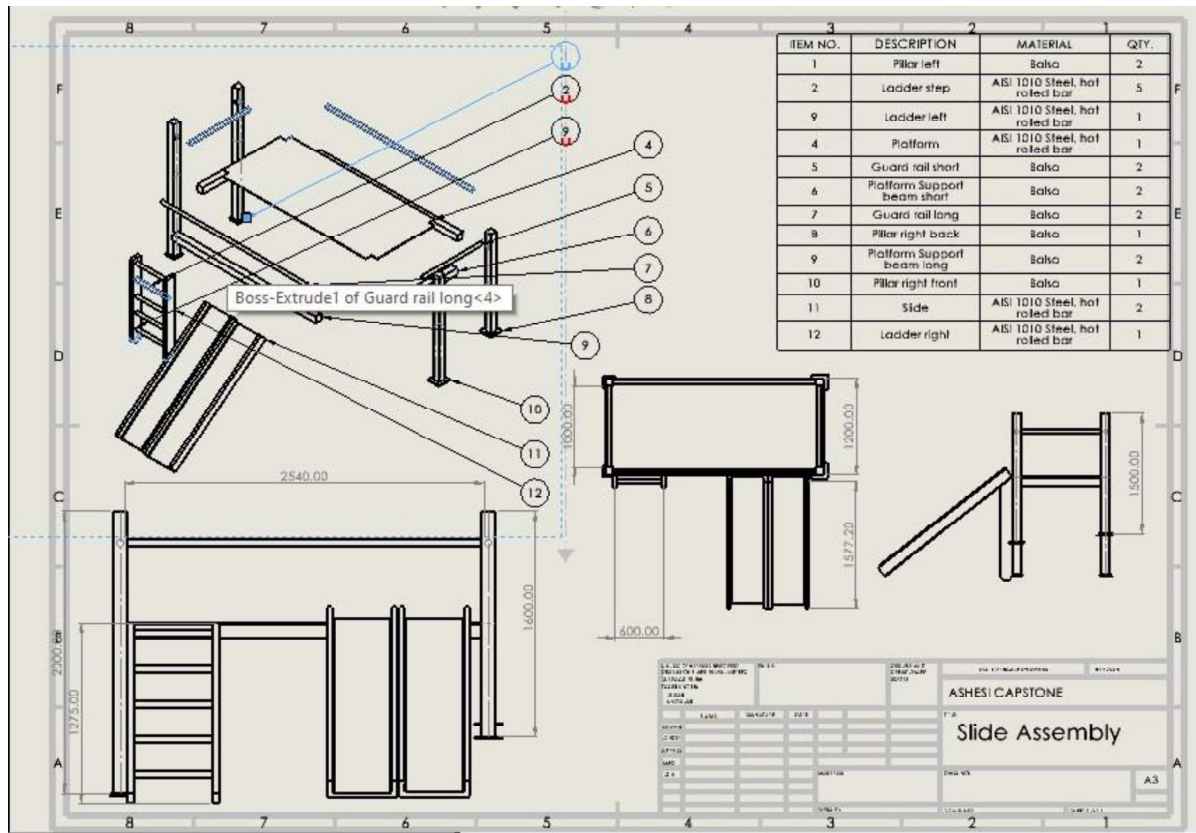

Figure B 4 Structure 3 Assembly Drawing and dimensions

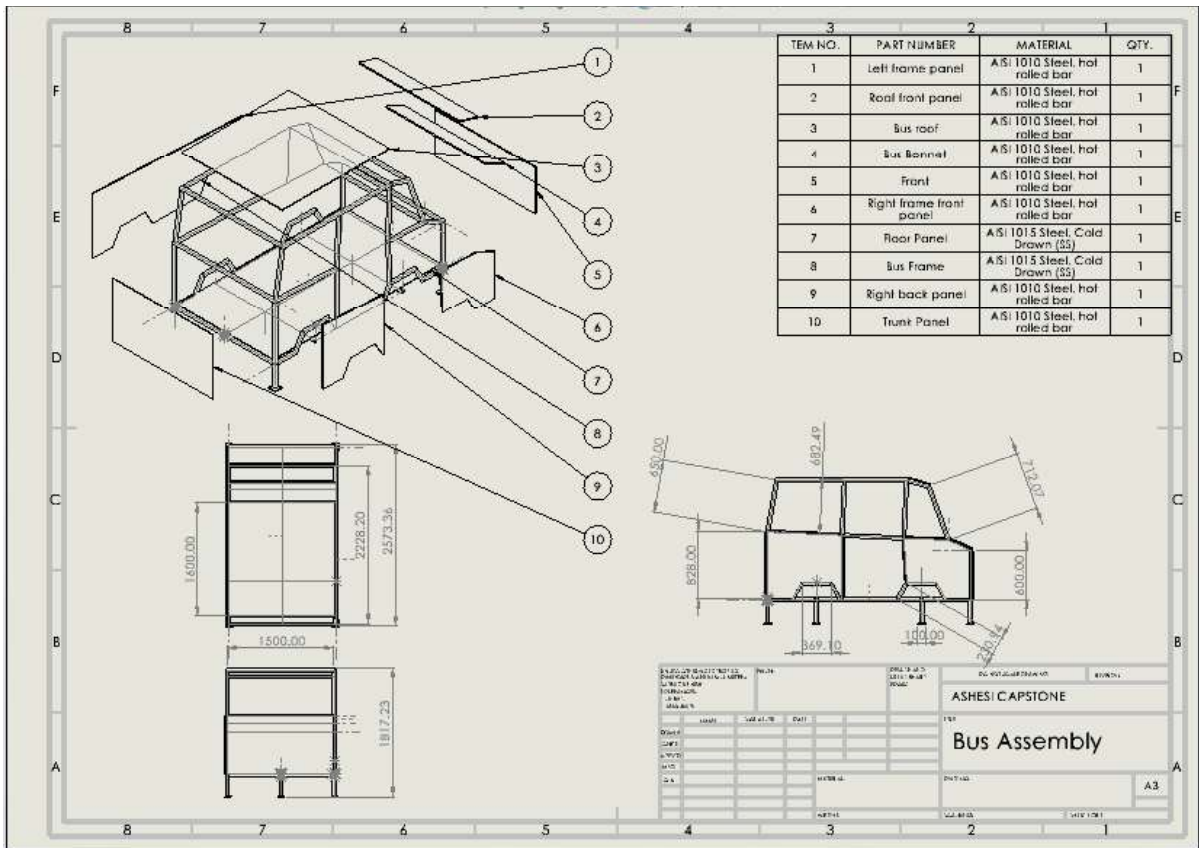

Figure B 5 Structure Assembly Drawing and dimensions