

# YALE PEABODY MUSEUM

P.O. BOX 208118 | NEW HAVEN CT 06520-8118 USA | PEABODY.YALE. EDU

## JOURNAL OF MARINE RESEARCH

The *Journal of Marine Research*, one of the oldest journals in American marine science, published important peer-reviewed original research on a broad array of topics in physical, biological, and chemical oceanography vital to the academic oceanographic community in the long and rich tradition of the Sears Foundation for Marine Research at Yale University.

An archive of all issues from 1937 to 2021 (Volume 1–79) are available through EliScholar, a digital platform for scholarly publishing provided by Yale University Library at <https://elischolar.library.yale.edu/>.

Requests for permission to clear rights for use of this content should be directed to the authors, their estates, or other representatives. The *Journal of Marine Research* has no contact information beyond the affiliations listed in the published articles. We ask that you provide attribution to the *Journal of Marine Research*.

Yale University provides access to these materials for educational and research purposes only. Copyright or other proprietary rights to content contained in this document may be held by individuals or entities other than, or in addition to, Yale University. You are solely responsible for determining the ownership of the copyright, and for obtaining permission for your intended use. Yale University makes no warranty that your distribution, reproduction, or other use of these materials will not infringe the rights of third parties.



This work is licensed under a Creative Commons Attribution-NonCommercial-ShareAlike 4.0 International License.  
<https://creativecommons.org/licenses/by-nc-sa/4.0/>



# MARINE LEPTOPEL, ITS RECOVERY, MEASUREMENT AND DISTRIBUTION<sup>1</sup>

By

DENIS L. FOX, JOHN D. ISAACS AND  
EUGENE F. CORCORAN

*University of California  
Scripps Institution of Oceanography  
La Jolla, California*

## ABSTRACT

Leptopel, the colloiddally or otherwise finely particulate organic and inorganic detritus suspended in natural bodies of water, varies in chemical composition and in relative quantities with reference to depth, latitude and proximity to land. The leptopelic material may be quantitatively recovered by passing the water through an ultrafilter of inert, insoluble adsorptive powder. Apparatus has been designed to so recover such samples *in situ* at various depths.

Leptopelic organic matter is present in rich concentrations in the feces of filter-feeding animals, which rely upon a constant supply of it as a source of nutrition; it is present also in marine slicks, especially in association with the surfaces of temporarily entrapped fine silt particles. Fine bottom deposits in regions near shore adsorb considerable quantities of organic detritus as well, while larger inorganic particles, such as sand, furnish less surface per unit of mass for physical attachment. Far smaller quantities of suspended organic matter have been recovered from deep water samples than from those near the surface. Feces from the California mussel, a detritus-feeding filterer, and leptopel from coastal slicks have yielded considerable proportions of organic nitrogen.

Emphasis is given to the significance of organic leptopel in biochemical cycles of the sea, involving the release of inorganic nitrogenous and phosphatic molecules by bacteria, the reassimilation of these soluble molecules by phytoplankton, and the *a priori* correlation between amounts of leptopel and populations of living communities.

## INTRODUCTION

Oceans, estuaries and inland bodies of water contain varying amounts of suspended *leptopel*, which is composed of finely particulate dispersed mud or sludge of organic and inorganic composition (*λεπτο-*, fine, thin: *πηλος*, mud or clay). Such materials, ranging in size from finely colloidal micelles to minute visible particles and including intimately associated micro-organisms such as bacterial cells, will vary in quantity and in chemical constitution with reference to latitude, depth, season and proximity to land.

<sup>1</sup>Contribution from the Scripps Institution of Oceanography, University of California, New Series No. 568.

Leptopel may be properly regarded as an attenuated hydrosol, the colloidal micelles of which, due to their constituent organic matter, may readily become somewhat concentrated at the water surface and at water-solid interfaces, there reducing the interfacial tension in accordance with the important principle first delineated by Willard Gibbs. At the surface of relatively quiet waters, the aggregations of leptopelic material may constitute extensive thin floating scums or slicks, readily observable by their contrasting optical properties. These effects are generated through diminution of the surface tension, rendering the water surface more elastic and resulting in substantial reduction in the height of the capillary waves (Ewing, 1950; Schmidt, 1936; Hardman, 1941).

The marine colloidal matter, when adsorbed to solid surfaces, such as those of submerged rocks, pilings, ships' hulls, sand or finer sediments, may assume the form of curds or of a more or less continuous semiliquid gel, muddy slime, or *pelogloea* (from  $\pi\eta\lambda\omicron\varsigma$  +  $\gamma\lambda\omicron\iota\alpha$ , slime, gum or oil). Sapropel is a special accepted term applied to the soft thin carpet of sludge or mud, rich in organic matter, lying upon some areas of the ocean floor.

It is manifest that the chemical, biological and sedimentational features, as well as the optical and surface studies in the realm of hydrography, must of necessity include serious consideration of leptopelic substances. The richness of bacterial flora, the production of soluble compounds of nitrogen, phosphorus and sulphur and their availability as plant nutrients, and indeed the level of general biological productivity, all must be intimately associated with the quantities of unorganized organic matter present in surrounding waters (cf. Keys, Christensen and Krogh, 1935). The physical and chemical character of sediments and the biochemical reactions occurring in them must vary greatly in accordance with the amounts of organic detritus adsorbed to the component silt, clay or sand.

Of salient interest to the marine biochemist is the direct utilization of finely particulate organic matter as a food by countless species of animals, whether by filtering the leptopel from the water with cilia, mucus-sheets, sieves, setae, or combinations of any of these, by scraping or sucking the pelogloea from solid surfaces, or by swallowing masses of whole sand, mud or sapropel at the shore line or at greater depths. Regions of relatively high leptopel concentration (e. g., near areas of river mouths, of sewage outfalls or of terrestrial run-off, or at gradually sloping rocky shores) will be expected to harbor the more dense populations of animals, including not only those species which subsist directly upon the finely divided organic matter but various

predatory forms as well (e. g., sea-stars, larger crustaceans, carnivorous mollusks and fishes) which devour the whole bodies or the gametes of herbivores and detritus-feeders (Fox, 1950).

Inorganic materials, suspended in the sea or floating on its surface, carry attached organic substances. For example, in tide pools formed in the sand about the pier pilings at the Scripps Institution and open to intermittent exchange of water at low tide, flakes of mica and other sand components float upon the water surface. Such material, collected upon a fine filter-membrane and dried overnight in an oven at temperatures reaching 120°, has shown, on ashing, that there are losses of from 1.07 to 1.32% in weight, representing the approximate amount of adsorbed organic matter (cf. beach-sand; Fox, Crane and McConnaughey, 1948).

Again, analyses of feces from a marine detritus-eating filter-feeder, the California mussel (*Mytilus californianus*), throw further light upon the composition of leptopelic marine detritus. Such material has shown an average ash content of 69.1%. Organic nitrogen (by Kjeldahl analysis) shows an average value of 1.1% which, when multiplied by the conventional factor of 6.25, gives approximately 6.9% protein in the whole feces or some 22.3% protein in the total organic matter in the feces. Lipids may amount to as much as 12%, or 38.7% of the organic fraction, leaving about 39% as carbohydrates or other components (cf. Fox and Coe, 1943).

Kalle (1946) has reported that yellow, blue-fluorescing ulmic acid-like derivatives, arising from such materials as decaying wood, peat, etc., reflect, by their relative concentrations, the quantities of terrestrial organic matter introduced by runoff into coastal waters.

Suspended materials in the English Channel have been studied by Armstrong and Atkins (1950). Some of the suspended solids were recovered by collecting water in wooden vessels and by passing large volumes of it through filter paper and through "Gradocol" membranes. The coarser particles retained in typical analyses yielded about 1 mg/l. Residual colloiddally dispersed material yielded traces of ash, involving about 60% SiO<sub>2</sub> and some 13% Fe<sub>2</sub>O<sub>3</sub>. The Tyndall beam was observed to persist in filtrates which had passed membranes of 0.2μ average pore diameter.

Dried, ignited residues reportedly ranged from 2.77 to 0.45 ppm, while the organic matter, measured in a few analyses by drying at 100°, amounted to about 1.5 ppm. While the porosity of the filters used by Armstrong and Atkins suggest that recovery was incomplete, the persistence of the Tyndall beam in the filtrates bearing out such a conclusion, the data agree rather well with the results obtained at La

Jolla. The British workers found in the ash of their recovered solids the following components in respective proportions:  $\text{SiO}_2$ , 17 to 55%;  $\text{Fe}_2\text{O}_3$ , 3 to 28%;  $\text{Al}_2\text{O}_3$ , 1 to 20%; and  $\text{CaCO}_3$ , 9 to 70%.

Comparative turbidimetric measurements of sea water samples have been conducted by Jerlov (1951), who employed the relative intensity of Tyndall scattering for following water movements in estuaries and through straits.

Investigations of marine leptopel are being pursued with the expectation that quantitative data may be gathered relative to the amounts and variations in colloidal and other particulate organic matter according to depth, latitude, season, and proximity to shore. Such data, it is hoped, may afford a correlative parameter that will supplement surveys of microplankton populations, studies of concentrations of dissolved oxygen, phosphate, nitrate and silicate, and observations of similar factors associated with marine biological productivity.

The presence of leptopel may be demonstrated by the gray or bluish Tyndall cone that is produced when a glass vessel (preferably a Florence flask) filled with sea or tap water is illuminated in a darkened room by a bright light (e. g. from a carbon arc) which passes through an adjustable slit or iris diaphragm and which is brought to a focus within the body of the fluid by means of a supplementary lens. The Tyndall cone is intensified by minimizing stray light and by placing the flask against a dark background; or better, black paint may be applied to the outer half of the flask's surface opposite the viewer.

After all colloidal and other finely suspended matter has been removed by passing the water through a sufficiently fine ultrafilter and collecting it in a scrupulously clean container, under appropriate illumination the water now manifests only the quality of a barely perceptible, soft blue-violet Tyndall cone which is given by twice-distilled water, as described by Lord Rayleigh and by Wood (1934, Chap. XIII). This so-called Rayleigh scattering is characteristic of pure air, pure water, and other homogeneous fluid molecules.

## MATERIALS AND METHODS

(a) *Collection by Adsorption.* The finely suspended matter may be quantitatively removed by passing the aqueous system through a short layer of finely powdered adsorptive inorganic material. Selection of an insoluble and relatively inert adsorbent permits quantitative investigations to be carried out on the particulate materials. For this purpose, various finely powdered or somewhat gelatinous compounds have been employed, including  $\text{MgO}$ ,  $\text{MgCO}_3$ ,  $\text{Fe}_2\text{O}_3$ ,  $\text{CaCO}_3$ ,  $\text{Mg}(\text{OH})_2$ , kaolin, talc and cellite (or Hyflo Super-cel, a refined diatoma-

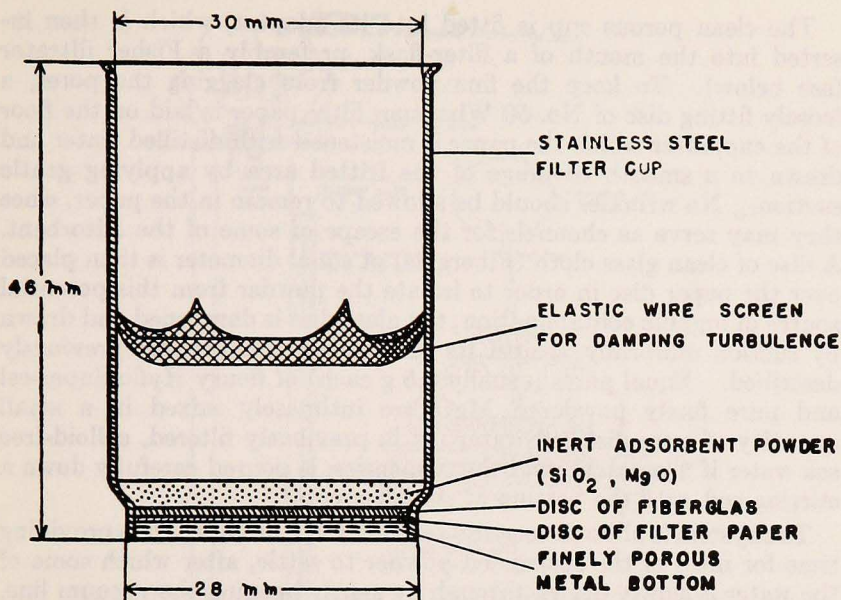

Figure 1. Diagram of stainless steel filter crucible, containing glass-cloth pad supporting inert adsorbent powder; ready for use.

ceous earth, substantially pure  $\text{SiO}_2$ ). Repeated investigations have been carried out on the complete adsorptive removal of finely dispersed protein micelles from aqueous systems, e. g., dilute sols of gelatin, egg albumin, hemoglobin, the latter two forming micelles of very small size (McBain, 1950: 128-129), or mixed fresh materials such as breis of mussel tissues. A separate report by Fox, Kittredge and Oppenheimer will deal with the quantitative adsorption achieved with the use of a mixture of equal weights of pure  $\text{MgO}$  and  $\text{SiO}_2$  (Hyflo Supercel).

It is necessary to employ amounts of the adsorbent in such excess as to assure quantitative adsorption of all particulate materials. Since most natural waters are extremely dilute disperse systems, the required excess of adsorbent is easily achieved by the method outlined below.

One or two grams of powder (equal weights of  $\text{MgO}$  and cellite) packed into a filter-cup (30 mm diameter) provide an operating column of adsorbent material some 6 to 8 mm high, which is sufficient to adsorb in a thin layer (1 to 2 mm) all colloidal material commonly encountered in large volumes of sea water. Standard glass crucibles with fritted glass bottoms are suitable in the laboratory, but for work at sea, similar cups of stainless steel are used because of their ruggedness (Fig. 1).

The clean porous cup is fitted into its adaptor, which is then inserted into the mouth of a filter-flask, preferably a Fisher filtrator (see below). To keep the fine powder from clogging the pores, a loosely fitting disc of No. 50 Whatman filter paper is laid on the floor of the cup, after which the paper is moistened with distilled water and drawn to a smooth coverage of the fritted area by applying gentle suction. No wrinkles should be allowed to remain in the paper, since they may serve as channels for the escape of some of the adsorbent. A disc of clean glass cloth (Fiberglas) of equal diameter is then placed over the paper disc in order to isolate the powder from this potential source of organic contamination; the glass disc is dampened and drawn by suction uniformly against its substrate in the manner previously described. Equal parts (usually 0.5 g each) of floury Hyflo Super-cel and pure finely powdered MgO are intimately mixed in a small quantity of pure distilled water (or in previously filtered, colloid-free sea water if necessary), and the suspension is poured carefully down a stirring rod onto the bottom of the filter-cup.<sup>2</sup>

The system is allowed to stand for about five minutes, thus providing time for most of the suspended powder to settle, after which some of the water is slowly drawn through by gently opening the vacuum line. Drawing through *all* of the water, thus exposing the filter-bed directly to the atmosphere, commonly leads to the formation of cracks and channels and to shrinkage from the walls of the cup. Should such channels occur through inadvertent exposure of the powder-cake, these should be filled with additional absorbent powder in suspension before conducting the ultimate filtration.

The preliminary filtration of reagent-water should proceed until a clear filtrate is obtained; this is frequently achieved at the outset or after only a small volume has been delivered within the first few minutes. Filtration is then halted *gently*, i. e., by gradually opening an intake valve in the vacuum line to avoid jarring the filter-pad loose from its firm seating. The design of the Fisher filtrator provides against such a contingency.

The prepared filter is permitted to stand, filled with water and undisturbed until ready for use. When collections are to be made

<sup>2</sup> In this operation a saturated solution of  $\text{Ca}(\text{OH})_2$  may be employed instead of water alone in order to provide sufficient traces of alkali to coat the adsorbing surfaces with  $\text{Mg}(\text{OH})_2$ , which is generated at once upon introduction of sea water. Excessive  $\text{Ca}(\text{OH})_2$  gives rise to sufficient  $\text{Mg}(\text{OH})_2$  to clog the filter; use of the powdered lime itself is therefore to be avoided. Even the saturated  $\text{Ca}(\text{OH})_2$  solution should be omitted if a balanced sea-water filtrate is desired for a biological medium.

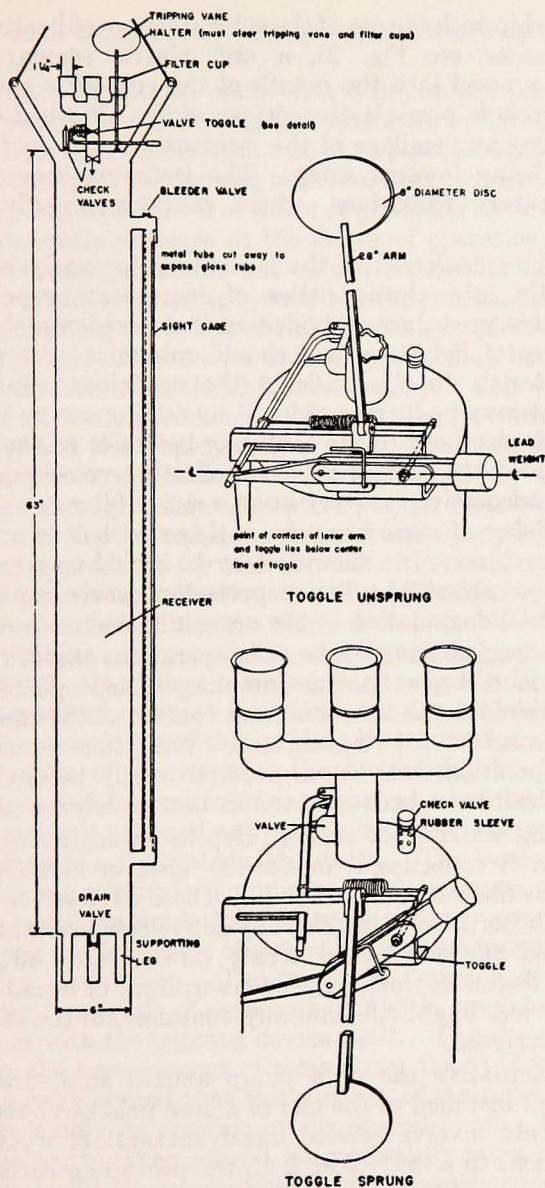

DIAGRAM OF FILTRATOR

DETAILS OF TOGGLE MECHANISM

Figure 2. Diagrammatic sketches of the Scripps Subsurface Autofiltrator and of detailed parts.



from aboard ship with the use of the subsurface autofiltrator (developed by J. D. Isaacs; see Fig. 2), a stiff elastic screen of stainless steel wire is pressed into the mouth of the cup for a short distance. This is to preclude possible disturbance of the filter-bed by intruding water following any spillage of the resident water from its cup while the gear is being lowered away. The buffering screen is omitted during laboratory operations, where cautious procedures may be assured.

Water to be transferred to the laboratory for analysis is best collected directly into clean bottles of inert water-repelling plastic material. This procedure provides against accidental breakage, affords a degree of lightness, and should minimize adsorption of the colloidal materials to the walls of the container. Such potential sources of loss may be further reduced by adding one or two grams of the powdered adsorbent to the container before or at the time of collection, provided the sample in each collecting vessel is destined for quantitative adsorptive recovery upon a single filter.

Should a delay of some hours be anticipated before water samples can be analyzed, mercuric chloride may be added to give a dissolved concentration of about 0.1 g/l; such procedure serves as a preservative against bacterial degradation of the organic matter.

(b) *The Subsurface Autofiltrator.* In operations at sea, an important requirement in the quantitative sampling of leptopelagic material *in situ* at any desired depth is to minimize contact of the raw water with any save the actual filtering surface. With this in mind, several alternative operations may be considered briefly before we describe the means which have been adopted as best satisfying requirements.

(1) Pumping water from selected depths through long tubes to a filter on deck, or collecting it in wooden, glass or metallic containers for subsequent filtration aboard ship. These devices are undesirable because: The adsorption of interfacially active colloidal materials to the extensive solid surfaces would create errors; later, after repeated operations, a degree of sloughing (or desorption) of accumulated films from such devices might substantially contaminate the samples to be filtered and analyzed.

(2) The alternative use of a pump aboard ship, drawing water through a filter installed at the end of a hose paid out overside. This procedure would involve several disadvantages: It would limit the pressure gradient to a low value, i. e., the prevailing barometric pressure, minus the height of the pump above the sea surface, minus the ambient vapor pressure of the water; the additional difficulties involved in storing and handling long tubes of fairly large diameter

would limit such a system to the use of relatively coarse filters at shallow depths.

(3) Subsurface collections made with a submerged pump, designed to draw the water directly through the juxtaposed filtering medium by providing a high gradient *in situ*. Such apparatus would possess the manifest advantage of minimizing time and area of prefiltering contact for processing large quantities of water at gradients limited only by the absolute hydrostatic pressure at the depth of operation. Disadvantages in such a design include not only the necessity of supplying a source of power and a metering system but the practically unavoidable risk of contaminating the collected residues with droplets of lubricating oil from the pump. However, a unique system may be applicable to filtration of samples while the ship is underway. This would involve submergence of the instrument to desired depths with a depressor (Isaacs, 1951) and the employment of the Venturi principle to obtain the required pressure gradients. The comparatively slow rates of water passage through a fine adsorptive powder filter would permit a multiplication of Venturi units, i. e., a small unit operating in the region of high velocity produced by a larger unit. Preliminary calculations have yielded promising indications for the application of such devices.

The subsurface autofiltrator which has been developed at the Scripps Institution is of reasonably simple and rugged design and is shown in Fig. 2. It utilizes a large heavy cylindrical receiver which permits the gradient between its interior (at atmospheric pressures or evacuated if necessary) and the ambient hydrostatic pressures outside to effect filtration of the water at the desired depth. The device is not lubricated, and it requires no mechanical metering system, since the filtered water is retained and can be measured directly at the end of the operation in a calibrated sight gauge. The factors of large size and bulkiness are relatively minor, since modern oceanographic gear is adapted for ready manipulation of large and heavy equipment.

The tripping mechanism is of somewhat unique design and deserves some detailed description. The toggle is designed to preserve its balance under conditions of severe linear shock, provided there be no actual contact with the tripping device itself. This design is achieved by balancing the first moment of mass about the fixed pivot.

It is to be remembered that the moment of the notched outer arm of the toggle is only its reaction at the central pivot. Having calculated this value, we then affixed an equivalent mass at the central pivot and balanced the mechanism against gravity around the fixed pivot. With a trapezoidal outer arm of thickness  $t$ , of density  $\rho$ , of length  $L$  and of major and minor altitudes  $A$  and  $B$  respectively, the reaction of the central pivot ( $R_1$ ) is:

$$R_1 = L^2 t \rho \left( \frac{A + 2B}{6} \right).$$

With an equivalent mass suspended at the central pivot, the lead counterweight is adjusted to produce a balance about the fixed pivot (see Fig. 3). The mechanism in current use has received heavy

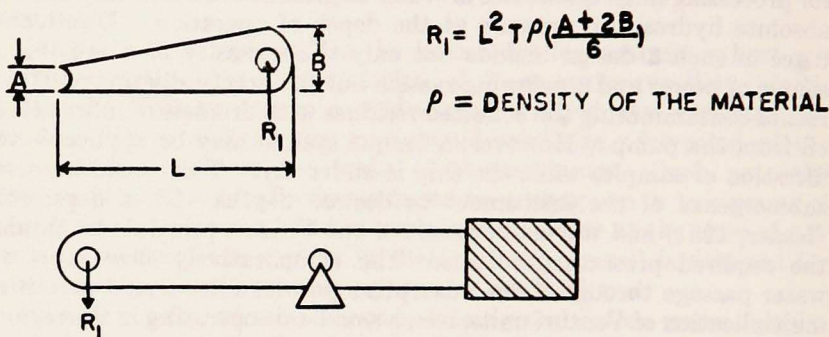

Figure 3. Representation of the forces involved in the tripping mechanism of the Scripps Subsurface Autofiltrator.

mechanical shocks without resultant tripping of the cocked toggle.

Accidental tripping of the toggle through premature falling of the vane (e. g., due to the roll of the ship or to wave action) is precluded by the length of the vane arm. The force of the arm against the toggle trigger should exceed by three- or four-fold that which is necessary to produce tripping. This requirement is readily calculated from the force relationships in the toggle (see Fig. 4).

The required thickness of the cylinder wall is calculated from the relationship:

$$P = \left( \frac{2E}{1-\mu^2} \right) \left( \frac{t}{D} \right)$$

where  $P$  = collapsing pressure,  $\mu$  = Poisson's ratio,  $t$  = thickness of wall,  $D$  = diameter to neutral axis, and  $E$  = Young's modulus.<sup>3</sup>

The thickness of the glass walls of the sight gauge may be selected in accordance with similar analysis, but adequate strength is to be found in any boiler gauge material adapted to meet high pressures.

In operations at sea, the stainless steel filter cup (or each of these if two or three are employed in order to shorten the filtration time) is furnished with the powdered filtering material in the manner previ-

<sup>3</sup> From "Implosion of cylinders," W. H. O. I. Report (unpublished).

ously described. An elastic stainless steel wire screen is pressed firmly into position at about half the depth of each cup, which is then filled with water. The toggle is cocked and the tripping vane is attached and held in a nearly vertical position with a single band of glued paper tape (a weak junction of paper readily torn apart when wet is preferable). To preclude the filtration of any sea water before the gear has

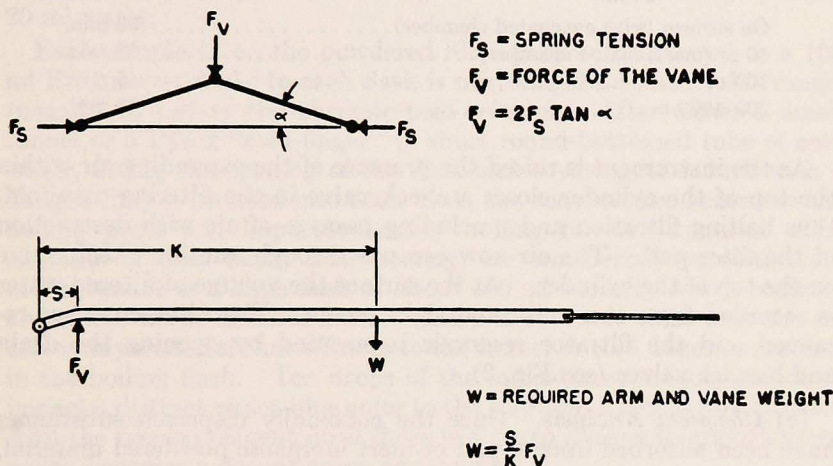

Figure 4. Diagram of force relationships in toggle.

been lowered to the desired depth, the short tube or filter manifold above the valve is filled with water until very little air space remains in the adaptors.

The prepared filter cups are now fitted into the open adaptors, which are supplied with rubber sleeves. With the tripping vane held in position by hand or by weak tape, depending on the amount of freeboard of the vessel and on the rapidity of lowering, the assemblage is lowered over the ship's side and the supporting cable is paid out to permit rapid sinking until the required depth has been achieved.<sup>4</sup>

When the cable meter indicates the required depth, lowering is abruptly halted, whereupon the tripping vane rotates into its downward position and its arm trips the toggle; thus the valve beneath the filter manifold is opened and the passage of water is initiated through the adsorptive powder and into the reservoir below. The time re-

<sup>4</sup> If lowering is accomplished rapidly enough, the vane arm will not fall sufficiently to trip the toggle before immersion and descent of the apparatus serves to prevent this; should the freeboard be too great to risk abortive tripping, the single lashing with paper tape may be applied, since this will come free shortly after submergence

quired for the collection of adequate samples (ca. 20 l of filtered water in the current model) will depend upon the hydrostatic pressure of each sampling depth and upon the fineness of the powder and the length of the powder column. Suggested intervals for the collection of from 15 to 20 l are as follows:

<i>Depth</i>	<i>Time Interval</i>
On surface (with evacuated chamber) . . . . .	30 min.
50 m (unevacuated chamber) . . . . .	20 min.
100 m . . . . .	15 min.
300-1000 m . . . . .	10 min.

As the instrument is raised the pressure of the expanding air within the top of the cylinder closes a check valve in the filtering manifold, thus halting filtration and precluding passage of air with destruction of the filter pad. The air now escapes through another check valve on the top of the cylinder. At the surface the volume of filtered water is recorded from the calibrated sight gauge. The filter cups are removed and the filtrator reservoir is emptied by opening the drain and bleeder valves (see Fig. 2).

(c) *Chemical Analysis.* Once the colloiddally dispersed substances have been adsorbed upon a pad of inert inorganic powdered material, it is possible to determine approximate concentrations of numerous constituents in terms of milligrams per liter of water filtered. Lipid materials may be extracted with organic solvents; chlorophyll or its porphyrin derivatives, as well as carotenoids, may be similarly recovered and measured photometrically; colloidal iron oxides and colloidal phosphate may be recovered and measured by special methods. Retained organic carbon and organic nitrogen may be determined. Preliminary reports of the methods and findings regarding the latter two components are given in this paper. Discussion of other constituents will be reported elsewhere.

The organic nitrogen content of adsorbed leptopel was determined by the Kjeldahl method; the sample was completely digested with boiling conc.  $H_2SO_4$ , and the resulting  $NH_3$  was distilled from the alkalinized system into a saturated boric acid solution and measured volumetrically (from a semimicroburette in this work) by titration with dilute standard HCl, using methyl orange as indicator.

The organic carbon content was measured by a rapid titration method outlined by Waksman (1936: 404-405). The reagents used are: (1) about 0.4 N chromic and sulphuric acid solution prepared by dissolving 40 g of  $K_2Cr_2O_7$  (or 32 g  $CrO_3$ ) in 1 l of  $H_2O$ , to which is added

conc.  $\text{H}_2\text{SO}_4$  (sp. gr. 1.84) to give 2 l of solution when cool; (2) about 0.2 N acidic ferrous ammonium sulphate, prepared with 80 g of the salt  $(\text{Fe}(\text{NH}_4)_2(\text{SO}_4)_2 \cdot 6\text{H}_2\text{O})$  and 20 ml of conc.  $\text{H}_2\text{SO}_4$ /l of solution, which is ultimately standardized with 0.1 N  $\text{KMnO}_4$  solution; 1 ml of the ferrous ammonium sulphate solution is taken as equivalent to 0.6 mg of organic carbon, or to 1.034 mg of humus. (3) Diphenylamine indicator prepared with 0.5 g dissolved in 100 ml conc.  $\text{H}_2\text{SO}_4$  + 20 ml water.

Each sample (i. e., the powdered filter pad) is transferred to a 100 ml Erlenmeyer flask; to each flask is next added a considerable excess (usually 10 ml) of the chromic acid solution. After either a small funnel or a Pyrex "cold-finger" (a short round-bottomed tube of cold water, fitting the opening of the flask and covering its mouth with a flanged rim) is inserted into each flask, the contents are heated to the boiling point and kept moderately boiling for five minutes. The contents of each flask, after cooling, are transferred quantitatively into a beaker or a large flask of about 400 ml capacity which contains about 250 ml of distilled water. Care is taken to rinse into the receiver any material that adheres to the funnel or cold finger or remains in the boiling flask. Ten drops of the indicator commonly suffice to impart a distinct violet-blue color to the solution, which is now titrated with the ferrous reagent until there is a sharp change to grayish green which becomes a deeper green on standing.

Multiplying the factor 0.6 by the difference between the observed titration figure and that of the control (i. e., 10 ml of chromic-sulphuric acid solution alone, previously boiled and diluted in the same manner) yields the empirical figure for the organic carbon content of the sample.

It is to be emphasized that the quantity of chromic acid reduced will naturally vary somewhat in accordance with the condition of the organic carbon involved, e. g., the degree in which it may already have been combined to some extent with oxygen, as in carbohydrate material  $(\text{CH}_2\text{O})_n$  or alternatively in a more reduced state, as in fatty acids, hydrocarbons, long-chain alcohols, and the like  $(\text{CH}_3\text{-CH}_2\text{-CH}_2 \dots)$ . The factor adopted applies to humic materials in general and has been retained throughout in the present work, since a part of our program deals with the determination of organic carbon of marine humus in sediments; it is highly probable that most samples of suspended leptopel will contain varying amounts of the relatively refractory humic material.

Table I shows a summary of quantitative findings relative to the amounts of leptopelic organic matter in marine waters and in other

TABLE I. RESULTS OF QUANTITATIVE STUDIES OF LEPTOPELIC AND PELOGLOEAL ORGANIC MATTER, COLLECTED AND ANALYZED IN VARIOUS WAYS.

Material	Method of Collection	Method of Analysis	Organic C	Organic N	Other Material	Total Organic Matter
1. Beach sand	Manual	Dry combustion				0.7%*
2. Floating mica	By aspiration	Dry combustion				a. 1.07% b. 1.32% av. = 1.2%
3. Mussel feces	Voided by freshly collected mussels	Organic matter by combustion; organic N by Kjeldahl; lipid-soluble matter by extraction with organic solvents		a. 1.02% b. 1.06% c. 1.19% d. 1.13% av. = 1.1% or 1.1 × 6.25 = 6.87% protein	Lipid-sol matter 3.7% (or ca. 12% of total organic matter)	a. 36.2% b. 30.7% c. 25.7% d. 31.1% av. = 30.9%†
4. Sedimentary component of a marine slick	In bottles, from surface, by G. C. Ewing	Wet chromate combustion of sediment				27.65%
5. Water from a slick area near shore in San Diego Harbor	In bottles, from surface, by G. C. Ewing a. turbid water from slick surface b. clear water 6" beneath slick c. clear water from rippled surface	Organic C by wet chromate combustion of adsorbed filter residues; organic N by Kjeldahl analysis of similarly recovered material	a. 6.77 mg/L b. 4.16 mg/L c. 5.9 mg/L C/N a. = 9.55 C/N b. = 9.25 C/N c. = 9.42	a. 0.71 mg/L = 4.44 b. 0.45 mg/L = 2.78 c. 0.63 mg/L = 3.94	mg protein/L	C × 1.8 N × 17 a. 12.20 12.05 b. 7.48 7.58 c. 10.70 10.54 av. a. 12.12 mg/L av. b. 7.53 mg/L av. c. 10.61 mg/L
6. Water from various oceanic depths off San Diego a. 9 l from 150 m, 32° 37' N, 120° 29' W b. 20 l from 600 m c. 20 l from 300 m d. 20 l from 100 m (all 3 samples from station at 33° 02' N, 118° 59' W)	Subsurface autofiltrator	Organic C by wet chromate combustion of adsorbate on Super-cel + MgO, 1:1	a. 0.47 mg/L  b. 0.14 mg/L c. 0.16 mg/L d. 0.17 mg/L			C × 1.8 a. 0.85 mg/L  b. 0.25 mg/L c. 0.29 mg/L d. 0.30 mg/L
7. Water from slick areas San Diego Channel	In bottles, by G. C. Ewing and M. W. Johnson; preserved with H <sub>2</sub> Cl <sub>2</sub> at time of collection a. from surface b. from near bottom (ca 10 m deep) c. from surface d. just beneath surface	Wet chromate combustion of adsorbate on Super-cel + Ca(OH) <sub>2</sub> , 1:1	a. 17.66 mg/L b. 19.64 mg/L  c. 11.61 mg/L d. 6.71 mg/L			Org. C × 1.8 a. 31.7 mg/L b. 35.3 mg/L  c. 20.9 mg/L d. 12.1 mg/L
8. Oceanic bottom mud, from station 32° 37' N, 120° 29' W (cf. item 6 in this table) a. 0-1 inch depth of mud b. 3-4 inch depth of mud c. 10-11 inch depth of mud	In coring sampler	Wet chromate combustion			Ash (%) H <sub>2</sub> O (%) in dried samples by difference)	Org. C. (%) Org. matter (%) (C × 1.7)
					a. 88.29 7.73 b. 85.59 11.32 c. 85.64 10.74	1.88 3.20 1.56 2.65 2.01 3.42

\* Fox, Crane and McConaughy, 1948.

† Fox and Coe, 1943; Fox, Updegraff and Novelli, 1944.

marine materials. It will be observed that concentrations of organic matter are relatively high in shallow waters near shore, especially in the vicinity of marine slicks (e. g., from about 7.5 to as high as 35 mg/l), while in water from considerable depths far from shore the values are relatively low (from 0.25 to 0.85 mg/l). In the data at hand there are higher concentrations of organic matter in the former than in the latter environment by some 40-fold.

Solid materials such as mussel feces or silt from a floating slick are relatively rich in organic matter, while beach sand and fine bottom sediments adsorb quantities of organic materials that yield intermediate values which are in rather good agreement with data presented by Revelle and Shepard (1939: 245-282).

It is also to be observed that the organic material recovered from both mussel feces and from a slick (items 3 and 5 respectively in Table I) were relatively rich in nitrogenous material. The four analyses of mussel feces yielded 17.6, 21.5, 28.9 and 22.7%, with an average value of 22.6% "protein," while the material from the slick gave 36.6, 36.9 and 37.1% respectively or an average figure of 36.9% "protein."

#### DISCUSSION

A brief review of relative masses of animate and unorganized colloidal or otherwise particulate organic matter in the sea may be of interest. The fact has been emphasized that "in any area of biological productivity, the total quantity of unorganized, raw material must considerably exceed the mass of organized living matter." (Fox, 1950; cf. also Keys, Christensen and Krogh, 1935).

Sverdrup, et al. (1942: 250-251, 912) have emphasized this point, citing the work of Krogh and of Bond (1933). While Krogh estimated that the "dissolved" organic material exceeds the "particulate" organic matter by some 300-fold, Bond's figures indicate a preponderance of only 76.9%, or some 3.3-fold of such "dissolved" organic matter over the combined amounts of net plankton and nanoplankton. Bond's investigations, carried out in waters near Friday Harbor, which are characteristically rich in phytoplankton, yielded average figures of 0.03, 0.03 and 0.20 mg-at C/l of water in net plankton, nanoplankton and dissolved organic matter respectively. These figures, multiplied by 12 to give mg of carbon, and by the factor of 2 to convert to organic matter, are 0.72, 0.72 and 4.8 mg/l. Bond's term "dissolved" naturally refers to colloidal and other suspended matter as well as such materials as may have been in true solution.

Reviewing the data obtained at La Jolla (including those presented here and by Fox and Coe, 1943) and those of Brandt (1898), we arrive



at some interesting approximate ratios of living phytoplankton to unorganized organic detritus in local waters. Living phytoplanktonic organisms in waters off La Jolla may supply average amounts of organic matter such as the following:

Dinoflagellates (ca.10,000/L; $2 \times 10^{-5}$ mg organic matter/cell)	0.2 mg/L
Diatoms (ca.20,000/L; $1.5 \times 10^{-6}$ mg organic matter/cell)	0.03 mg/L
Bacteria (ca.45,000,000/L; $5 \times 10^{-11}$ mg organic matter/cell)	<u>0.002 mg/L</u> ca. 0.23 mg/L

Now, if we take 5 mg/l as an average value for total colloidal or otherwise finely particulate organic matter, the living fraction would appear to be only some 4% of the total; but if we should adopt the figure of 15.3 mg/l (the average value of collective data in items 5 and 7, Table I), then the proportion of living cells would appear to be only about 1.5% of the total.

Marine biochemical cycles undoubtedly entail close parallelism between fluctuations in populations of microplankton and concentrations of suspended organic detrital materials. It would be unlikely that the mass of living cells, even of phytoplankton, should exceed that of suspended detritus in any area, save for relatively brief periods.

#### ACKNOWLEDGMENTS

The authors gladly acknowledge the cooperation of the following: Dr. Roger Revelle for advice, encouragement, and for aid in making available the deep oceanic samples; Dr. Gifford C. Ewing and Dr. Martin W. Johnson for collection of certain water samples in the vicinity of slicks; Mr. Wheeler J. North for helpful advice and for preparing the drawings; the Rockefeller Foundation for a grant in aid of this research, and the Bureau of Ships of the United States Navy for supporting the development of the activating mechanism of the autofiltrator.

#### SUMMARY

The nature, methods of quantitative recovery, chemical measurements, and distribution of organic materials in marine lepto pel are discussed.

Marine detrital organic matter is relatively concentrated in solid material such as the feces of filter-feeding animals, in finer sediments on the ocean floor or in fine silt temporarily suspended in surface slicks. It shows intermediate concentrations in waters removed from

the vicinity of slicks and is recoverable in relatively low concentrations from water a few hundred meters in depth, at some distance from shore.

The quantitative determination of organic leptopel is discussed as a useful parameter in studying marine biochemical cycles, and discussion is given to the general ratio between the weight of organic matter in living microplankton and the total mass of organic substances in suspended marine detritus.

## REFERENCES

- ARMSTRONG, F. A. J. AND W. R. G. ATKINS  
1950. The suspended matter of sea water. *J. Mar. biol. Ass. U. K.*, 29: 139-143.
- BOND, R. M.  
1933. A contribution to the study of the natural food-cycle in aquatic environments. *Bull. Bingham oceanogr. Coll.*, 4 (4): 1-89.
- BRANDT, K.  
1898. Beiträge zur Kenntnis der chemischen Zusammensetzung des Planktons. *Wiss. Meeresunters., Abt. Kiel. N. F.* 3: 45-90.
- EWING, GIFFORD  
1950. Slicks, surface films and internal waves. *J. Mar. Res.*, 9: 161-185.
- FOX, D. L.  
1950. Comparative metabolism of organic detritus by inshore animals. *Ecology*, 31: 100-108.
- FOX, D. L. AND W. R. COE  
1943. Biology of the California sea mussel (*Mytilus californianus*). II. Nutrition, metabolism, growth and calcium deposition. *J. exp. Zool.*, 93: 205-249.
- FOX, D. L., S. C. CRANE AND B. H. MCCONNAUGHEY  
1948. A biochemical study of the marine annelid worm, *Thoracophelia mucronata*. Its food, biochromes and carotenoid metabolism. *J. Mar. Res.*, 7: 567-585.
- FOX, D. L., D. M. UPDEGRAFF AND G. D. NOVELLI  
1944. Carotenoid pigments in the ocean floor. *Arch. Biochem.*, 5: 1-23.
- HARDMAN, YVETTE  
1941. The surface tension of Wisconsin Lake waters. *Trans. Wis. Acad. Sci. Arts Lett.*, 33: 395-404.
- ISAACS, J. D.  
1951. Homogeneous Depressor. Progress Report, Bureau of Ships. Rep. Scripps Inst. Oceanogr., 51-10. Aug. 1, 1951. 5 pp. plus 3 plates.
- JERLOV, N. G.  
1951. Optical measurement of particle distribution in the sea. *Tellus*, 3: 122-128.
- KALLE, KURT  
1946. Fluoretzung und Gelbstoffgehalt im Bottnischen und Finnischen Meerbusen. Unpubl. Sci. Rep., Serial No. 28 from Deutsch. Hydrogr. Inst., U. S. Hydrographic Office.

KEYS, A., E. H. CHRISTENSEN AND A. KROGH

1935. The organic metabolism of sea-water with special reference to the ultimate food cycle in the sea. *J. Mar. biol. Ass. U. K.*, 20: 181-196.

McBAIN, J. W.

1950. *Colloid Science*. D. C. Heath and Co., Boston. 450 pp.

REVELLE, ROGER AND F. P. SHEPARD

1939. Sediments off the California coast. In *Recent Marine Sediments*, Amer. Ass. Petrol. Geol., Tulsa, Okla. 736 pp.

SCHMIDT, W.

1936. Causes of 'oil patches' on water surfaces. *Nature, Lond.*, 137: 777.

SVERDRUP, H. U., M. W. JOHNSON AND R. H. FLEMING

1942. *The Oceans*. Prentice Hall, Inc., New York. 1087 pp.

WAKSMAN, S. A.

1936. *Humus*. Williams and Wilkins, Baltimore. 494 pp.

WOOD, R. W.

1934. *Physical Optics*. MacMillan, New York. 846 pp.