

YALE PEABODY MUSEUM

P.O. BOX 208118 | NEW HAVEN CT 06520-8118 USA | PEABODY.YALE. EDU

JOURNAL OF MARINE RESEARCH

The *Journal of Marine Research*, one of the oldest journals in American marine science, published important peer-reviewed original research on a broad array of topics in physical, biological, and chemical oceanography vital to the academic oceanographic community in the long and rich tradition of the Sears Foundation for Marine Research at Yale University.

An archive of all issues from 1937 to 2021 (Volume 1–79) are available through EliScholar, a digital platform for scholarly publishing provided by Yale University Library at <https://elischolar.library.yale.edu/>.

Requests for permission to clear rights for use of this content should be directed to the authors, their estates, or other representatives. The *Journal of Marine Research* has no contact information beyond the affiliations listed in the published articles. We ask that you provide attribution to the *Journal of Marine Research*.

Yale University provides access to these materials for educational and research purposes only. Copyright or other proprietary rights to content contained in this document may be held by individuals or entities other than, or in addition to, Yale University. You are solely responsible for determining the ownership of the copyright, and for obtaining permission for your intended use. Yale University makes no warranty that your distribution, reproduction, or other use of these materials will not infringe the rights of third parties.



This work is licensed under a Creative Commons Attribution-NonCommercial-ShareAlike 4.0 International License.
<https://creativecommons.org/licenses/by-nc-sa/4.0/>



On the mutual adjustment of pressure and velocity distributions in certain simple current systems, II

by C.-G. Rossby¹

In a previous report (Rossby 1937) the author investigated certain changes in the mass distribution which accompany the slow lateral diffusion of momentum in a straight parallel current in an unlimited ocean of constant depth. The principal results of this investigation may be stated as follows:

The main stream increases slowly in width (for large times (t) it is proportional to $(t^{1/4})$ while the maximum velocity in the axis of the current gradually decreases (being proportional to $t^{-1/4}$ for large values of t). If no frictional losses occur at the bottom the total *absolute* momentum of the current remains constant. The diffusion is accompanied by a slight banking to the right of the down stream direction, in such a fashion that the difference in height of the free surface between the right and the left edges of the current eventually increases by about eight per cent. Weak counter currents develop on both sides of the main stream as a result of the banking.

This analysis of the disintegration of a current system is supplemented in the present article with a study of the mutual adjustment of mass and velocity distributions in a current system which is gradually being built up by a prescribed wind system acting upon a portion of the ocean surface. The problem will be analyzed in several stages, to bring out more clearly the mechanics of the adjustment process. Frictional forces resulting from lateral mixing will be neglected in the present study but will be included in a third article to be published in a later issue of this journal.

We shall consider at first a homogeneous, incompressible ocean of constant depth D_0 , which is at rest initially. Through wind action a certain amount of momentum is communicated to an infinite strip of the width $2a$. The details of the mechanism of this transfer are not important in the present connection. It is sufficient to say that the fluid column between $y = +a$ and $y = -a$ is endowed with a certain mean velocity u in the positive x -direction. The y -direction is horizontal, normal to the x -direction and points to the left

1. Massachusetts Institute of Technology and Woods Hole Oceanographic Institution, Contribution No. 185.

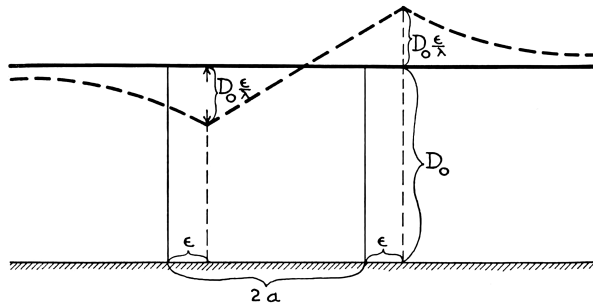

Figure 84. Schematic representation of the adjustment of mass distribution in a homogeneous ocean. See text.

from the x -direction. The momentum relative to the surface of the earth per unit length of current is then given by the expression $2\rho u_0 a D_0$, ρ being the density of the water.

This momentum (M) is associated with a Coriolis' force of the magnitude fM and directed 90° to the right of the momentum. In this expression f represents the Coriolis' parameter. As no balancing pressure gradient exists, the current will move to the right until enough of a pressure gradient has been established to check further deflection. It is the purpose of this first preliminary calculation to determine the characteristics of the final equilibrium state.

Frictional forces resulting from lateral mixing will be neglected outside the main stream. Within the stream they are assumed to maintain a laterally constant axial velocity which, however, as a result of the displacement of the current to the right must decrease during the adjustment. Since, the lateral stresses merely bring about a redistribution, not a change, of the absolute momentum, the permissibility of the above assumptions depends upon whether a significant redistribution occurs within the interval required for the adjustment process here considered. This question will be considered later.

The general character of the adjustment process is indicated by the cross section in Figure 84, which is drawn to facilitate the understanding of the analysis but does not correspond to any actual numerical solution. If one assumes that the velocity distribution across the main stream is constant after completed adjustment, it follows that the free surface in the final equilibrium must have a constant slope within the current itself.

During the adjustment the individual fluid columns to the left of the main current shrink vertically, stretch horizontally. Let y_0 represent the initial position of a given fluid vertical to the left of the main stream, y its final position. The equation of motion for the x -direction (current axis) takes the form

$$\frac{du}{dt} = fv, \quad (1)$$

there being no pressure gradient in the x -direction and no frictional force. Integration gives

$$u = f(y - y_0) = -f(y_0 - y), \quad (2)$$

indicating that each fluid column on completed adjustment will move upstream at a speed proportional to its total displacement to the right.

If the final depth of a certain column is indicated by D , its initial depth by D_0 , the equation of continuity takes the form

$$Ddy = D_0dy_0 \quad (3)$$

or

$$D = D_0 \frac{dy_0}{dy}. \quad (4)$$

After completed adjustment gradient motion prevails. Thus

$$0 = -fu - g \frac{dD}{dy}. \quad (5)$$

Combination of (2), (4) and (5) gives

$$\frac{d^2y_0}{dy^2} = \frac{y_0 - y}{\lambda^2}, \quad (6)$$

where

$$\lambda = \frac{1}{f} \sqrt{gD_0}. \quad (7)$$

A similar differential equation may be obtained for D ,

$$\frac{d^2D}{dy^2} = \frac{D - D_0}{\lambda^2}, \quad (8)$$

and this equation is a special case of a more general equation

$$\frac{\partial^2 D}{\partial x^2} + \frac{\partial^2 D}{\partial y^2} = \frac{D - D_0}{\lambda^2}, \quad (9)$$

valid for arbitrary quasistatic transformations of an originally motionless incompressible fluid sheet of the initial depth D_0 .² This last equation expresses the conservation of absolute vorticity.

The length λ is a fundamental parameter in all quasistatic deformations. It is possible to define such a length also for stratified and compressible media, such as the atmosphere. In view of its great significance it seems appropriate to introduce a special name for this

2. The term quasistatic transformation is employed here in preference to the term adiabatic transformation which is generally used in Mechanics to designate processes of this type but which would be ambiguous in meteorology and also to some extent in oceanography (for a definition and discussion of adiabatic transformations see for instance, A. Sommerfeld, *Atombau und Spektrallinien*, 3. Auflage, Vieweg, Braunschweig, 1922).

quantity. Its magnitude is that of the radius of the inertia circle corresponding to the velocity of long waves in a channel of the depth D_0 . It is proposed to name λ *the radius of deformation*.

Integration of (6) gives

$$y_0 - y = Ae^{\frac{y}{\lambda}} + Be^{-\frac{y}{\lambda}}, \quad (10)$$

A and B being arbitrary constants of integration. Since the displacement $y_0 - y$ must vanish at great distances to the left from the main current (large y -values), it follows that

$$A = 0 \quad (11)$$

and thus

$$y_0 - y = \varepsilon e^{-\frac{y}{\lambda}}, \quad (12)$$

ε being the total displacement to the right, of the left edge of the main stream. In this formula the y -coordinate is counted from the final position of the left edge of the main stream.

The depth of the free surface at the left edge of the current (D_l) is given by (4) and (12),

$$D_l = D_0 \left(1 - \frac{\varepsilon}{\lambda} \right). \quad (13)$$

By a similar analysis it is possible to compute the rise of the free surface along the right edge of the current for an equal displacement ε to the right. The result is

$$D_r = D_0 \left(1 + \frac{\varepsilon}{\lambda} \right). \quad (14)$$

The slope of the free surface across the main stream is now given by $\frac{1}{2a}(D_r - D_l)$. Thus, since gradient wind must prevail in the final equilibrium, it follows that the final mean velocity u_f , of the main stream must be given by

$$u_f = \frac{g}{f} \frac{1}{2a} (D_r - D_l) = \frac{gD_0\varepsilon}{f\lambda a} = \frac{\lambda}{a} f \varepsilon. \quad (15)$$

The displacement of the main stream cannot have changed its absolute momentum. This constancy is expressed by an equation derived previously (Rossby 1937, p. 19)

$$\int_{-a+\varepsilon}^{a+\varepsilon} D_0 (u_0 - fy) dy = \int_{-a}^{+a} D (u_f - fy) dy, \quad (16)$$

the y -coordinate on both sides of the equation being counted from the final center of the current.³ Since u_o , u_f , and D_o are constants, it follows that

$$2aD_o u_o = u_f \int_{-a}^{+a} D dy + f \int_{-a+\epsilon}^{a+\epsilon} D_o y dy - f \int_{-a}^{+a} D y dy. \quad (17)$$

The first integral on the left side gives the volume, which remains constant and equal to $2aD_o$. Thus

$$2aD_o (u_o - u_f) = fD_o \int_{-a+\epsilon}^{a+\epsilon} y dy - f \int_{-a}^{+a} D y dy. \quad (18)$$

The appropriate expression for D is obtained from (13) and (14). It has the form

$$D - D_o = -D_o \frac{\epsilon y}{\lambda a}. \quad (19)$$

If this expression is substituted in (18) one finds, after some reductions,

$$u_f = u_o - f\epsilon \left(1 + \frac{a}{3\lambda}\right). \quad (20)$$

It is easy to verify that the product $\epsilon \left(1 + \frac{a}{3\lambda}\right)$ represents the total displacement to the right of the mass center of the current during the adjustment. If (15) and (20) are combined it follows that

$$\epsilon = \frac{u_o}{f} \frac{1}{1 + \lambda/a + a/3\lambda} \quad (21)$$

and, from (15) and (21),

$$u_f = u_o \frac{\lambda/a}{1 + \lambda/a + a/3\lambda}. \quad (22)$$

3. It is of course possible to treat the adjustment of the main stream by the same exact method which was used above in treating the environment. For the main stream, equation (2) changes into

$$u = u_o - f(y_o - y) \quad (2a)$$

and the differential equation (6) into

$$\frac{d^2 y_o}{dy^2} = \frac{1}{\lambda^2} \left(y_o - y - \frac{u_o}{f} \right). \quad (6a)$$

The solution of this differential equation is

$$y_o - y = \frac{u_o}{f} + Ae^{\frac{y}{\lambda}} + Be^{-\frac{y}{\lambda}}, \quad (10a)$$

the two integrations constants A and B being needed to satisfy the requirement of continuity in displacement at the two boundaries. The over-all method used above is, however, amply sufficient for our present needs.

In middle latitudes ($f = 10^{-4} \text{ sec.}^{-1}$) the radius of deformation has a value of 1400 km. for a basin of 2 km. depth. If the current has a width of 200 km. ($a = 100 \text{ km.}$) and an initial velocity of 50 cm. p. s. it follows that a displacement of one third of one kilometer would be sufficient to establish the required balancing pressure gradient. The initial velocity would be reduced by seven percent as a result of the deflection and the maximum counter current velocity on both sides of the main stream would be about 3.3 cm. p. s.

By the time the main stream reaches its equilibrium position it has acquired a finite velocity to the right and must therefore continue its displacement beyond the equilibrium point until an excessive pressure gradient develops which forces it back. An *inertia* oscillation around the equilibrium position results. It is well known that the period of such an oscillation must be half the pendulum day. The main stream will therefore reach the equilibrium position already in a few hours. From the rapidity of this adjustment it follows that large unbalanced momenta never have time to accumulate. It is probably more correct to assume that the momentum is added quasistatically, in such a fashion that each infinitesimal amount of momentum leads to a practically instantaneous adjustment of the mass distribution. Since a normal wind stress of, say, 1 dyne per cm.^2 acting on top of a 2 km. deep water column produces a mean momentum per unit mass of less than 0.5 cm. p.s. per day it would appear that the assumption of quasistatic adjustment must be very nearly fulfilled. However, as long as the addition of momentum takes place at a variable and finite rate, a certain fraction of the energy communicated to the system will presumably always appear as an inertia oscillation. The preceding result, that changes in the stress distribution on the ocean surface necessarily must lead to inertia oscillations, was clearly recognized by Ekman in his early studies of drift currents (Ekman 1905).

It is evident that while the frictional redistribution of momentum during the period of one inertia oscillation may be quite negligible, the total time required for the building up, through wind action, of a gradient current of the magnitude assumed above is so long that it certainly would be utterly impermissible to neglect the diffusion of momentum during this entire period.

It is next desired to investigate the effect of stratification on the process of mass adjustment. A simple case will be analyzed to bring out the nature of the modification which has to be made in the preceding analysis.

Figure 85 is a schematic representation of the adjustment process in a two-layer ocean, the upper layer having the density ρ , the lower the density ρ' . The undisturbed thicknesses of the two layers is D_0 and D'_0 . It is now assumed that an infinitely long strip of the upper fluid, enclosed between the limits $y_0 = a$ and $y_0 = -a$, is endowed with a velocity u_0 . A deflection of the current results and continues until a balancing pressure gradient has been established across the main stream.

The pressure gradients which develop in the upper layer during the adjustment must set the lower homogeneous layer in motion. However, if the latter is very deep it is possible to demonstrate that its displacements and final velocities must be fairly small. It is possible to analyze exactly the adjustment of the lower layer using the method which was applied above

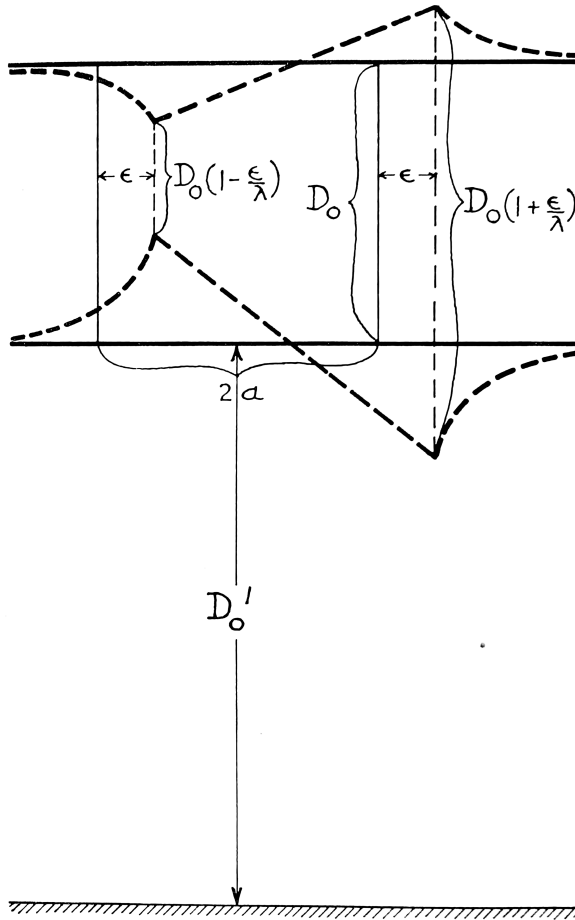

Figure 85. Schematic representation of the adjustment of mass distribution in a double layer ocean. See text.

to the environment of the main stream in the single-layer case. This will be done later on. As a first approximation, however, it is sufficient to assume that the lower layer remains at rest; thus the deep water displacements associated with deformations of the internal boundary lead to negligibly small axial velocities. This restriction will be removed later.

If the bottom remains at rest it follows that

$$\rho D + \rho' D' = \text{constant} \tag{23}$$

and consequently

$$\frac{d}{dy} (D + D') = \frac{\rho' - \rho}{\rho'} \frac{dD}{dy} = - \frac{\rho' - \rho}{\rho} \frac{dD'}{dy}. \tag{24}$$

It is evident from (23) and (24) that the slope of the internal boundary is always proportional and opposite to the slope of the free surface, which is given by the left side in (24). The preceding analysis, including equations (2), (3) and (4), remains unchanged. The gradient current equation (5) changes into

$$0 = -fu - g \frac{d}{dy} (D + D') \quad (25)$$

or, because of (24),

$$0 = -fu - g \cdot \frac{\rho' - \rho}{\rho'} \frac{dD}{dy}. \quad (26)$$

Thus, if one reduces the acceleration of gravity in the proportion $\frac{\rho' - \rho}{\rho'}$ and substitutes for g a value γ , defined by

$$\gamma = g \cdot \frac{\rho' - \rho}{\rho'} \quad (27)$$

all the previously derived results remain valid. The system is in every respect identical with a single-layer ocean of the depth D and subject to an acceleration of gravity of the value γ . The substitution (27) has one very important consequence. The radius of deformation, defined in (7), is now given by

$$\lambda = \frac{1}{f} \sqrt{\gamma D_0} = \frac{1}{f} \sqrt{\frac{\rho' - \rho}{\rho'} g D_0}. \quad (28)$$

Assuming an upper homogeneous layer with an original depth $D_0 = 400$ m, and assuming a density discontinuity of 0.2 percent, it follows that

$$\lambda = 28 \text{ km.} \quad (f = 10^{-4} \text{ sec.}^{-1}).$$

The radius of deformation is thus reduced to $\frac{1}{50}$ of its original value. Assuming the same values for u and a as before, the deflection of the current will now be about 2 km. compared with the previous value of 0.33 km. The reduction in the mean speed of the current due to this deflection is greatly increased, the final axial velocity u_f having a value of about 5.3 cm. p. s. and the counter currents are correspondingly increased to about 20 cm. p. s. The radius of deformation measures that distance from either edge of the main stream in which the counter current velocity has fallen off to the fraction $\frac{1}{e}$ of its maximum value, and this distance is now reduced to $\frac{1}{50}$ of its previous value. Thus the adjustment of the mass distribution will be accompanied by the development of strong and narrow counter currents, while the corresponding currents in the homogeneous case will be very broad and extremely weak.

The preceding results suggest that the adjustment of the mass distribution in a stratified medium will be accompanied by a more intense development of inertia oscillations than the

corresponding adjustment in a homogeneous medium. It is actually possible to compute the energy available for inertia oscillations by forming the difference between the total energy before and after adjustment. Such a calculation is easily made and clearly indicates that a much larger fraction of the initial energy goes into the oscillating motion in the stratified case than in the homogeneous.

It is found that the initial energy E_0 , given by the expression

$$E_0 = \rho a D_0 \cdot u_0^2,$$

and the final energy E_f are related through the formula

$$E_f = E_0 \cdot \frac{\frac{\lambda}{a}}{1 + \frac{\lambda}{a} + \frac{a}{3\lambda}} \quad (29a)$$

and thus the fraction of the initial energy available for inertia oscillations is given by

$$E_{oscillation} = E_0 \frac{1 + \frac{a}{3\lambda}}{1 + \frac{\lambda}{a} + \frac{a}{3\lambda}} \quad (29b)$$

This last expression is not quite correct, a small error resulting from the assumption that the velocity of the main stream is constant laterally also in the final equilibrium state. This error is not significant in the single layer case but may be of some consequence in a stratified medium. A comparison of the two cases discussed above indicates that in the single-layer ocean only 7% of the initial energy goes into inertia oscillations, whereas in the second case the major portion of the initial energy (89%) must appear as an inertia oscillation.

Since most currents are built up through a fairly gradual addition of momentum the numerical values obtained through the suggested application of the energy integral are of small significance. Nevertheless, because of the variability of the surface stresses it appears probable that vigorous inertia oscillations must develop in stratified media and express themselves as a marked intensification of the large-scale horizontal turbulence which must develop due to the dynamic instability of the shearing zones between the current and its surrounding counter currents (Pekeris 1938). Such intensification would not occur in homogeneous media. This tentative conclusion agrees well with Parr's suggested relationship between lateral mixing and vertical stability (Parr 1936).

The total amount of momentum received from the wind per unit time is distributed over a much deeper column in the case of a single-layer homogeneous ocean than in the case of stratified water. Thus the initial unbalanced velocity components will be stronger in stratified than in homogeneous water and this fact would further favor the development of lateral turbulence in stratified water.

We shall next consider motions set up in the deeper of the two layers as a result of displacements and mass adjustments in the upper layer. It is assumed that no tangential stresses are transmitted through the boundary between the two strata. Originally the lower layer is at rest and characterized by a constant depth D'_0 .

During the adjustment process the internal boundary will be deformed. Since continuity of mass must be preserved it follows that

$$D' dy' = D'_0 dy'_0, \quad (30)$$

y'_0 and y' being the initial and final positions of a given fluid vertical.

The equation of motion for the x -direction is given by

$$\frac{du'}{dt} = fv' \quad (31)$$

or, after integration,

$$u' = f(y' - y'_0) = -f(y'_0 - y'). \quad (32)$$

It will now be assumed that wind action or other processes have led to the establishment of a known horizontal pressure gradient in the upper layer. The problem is to determine the final velocity u' in the lower layer for prescribed values of the gradient current u in the upper layer.

It is of course possible to assume that an initially unbalanced current component exists in a portion of the upper layer and to solve simultaneously the equations which describe the adjustment processes in the two layers. In this case the adjustment of the mass distribution is accomplished through a transversal circulation which, to an observer looking down stream, takes place in a clock-wise sense (see Fig. 85). Such clock-wise circulations have been observed in the California current during periods of acceleration and estimates of their intensity have been made (Sverdrup 1938). An exact solution of a problem of this type will be presented by Mr. H. Wexler and the author in a later issue of this journal. For the present we shall restrict ourselves to the case of a prescribed pressure distribution, or gradient current system, in the upper layer. If this new pressure distribution in the upper layer is applied quasistatically the solution presented below represents the final equilibrium state. If it is applied suddenly or built up at an irregular rate, inertia oscillations will appear, both above and below, superimposed upon the equilibrium state here computed.

The depth of the upper layer is D . The height of the free surface is given by $D + D'$ and thus

$$u = -\frac{g}{f} \frac{d}{dy'} (D + D'). \quad (33)$$

The gradient current equation for the lower layer takes the form

$$u' = -\frac{g}{\rho' f} \frac{d}{dy'} (\rho D + \rho' D') \quad (34)$$

or

$$u' = \frac{\rho u}{\rho'} - \frac{\gamma}{f} \frac{dD'}{dy'}. \quad \left(\gamma = \frac{\rho' - \rho}{\rho'} g \right). \quad (35)$$

A combination of (30), (32) and (35) gives

$$\frac{d^2 u'}{dy'^2} - \frac{u'}{\lambda'^2} = - \frac{\rho}{\rho'} \frac{u}{\lambda'^2}, \quad (36)$$

the radius of the deformation λ' now being given by

$$\lambda' = \frac{1}{f} \sqrt{\gamma D_o'} = \frac{1}{f} \sqrt{\frac{\rho' - \rho}{\rho'} g D_o'}. \quad (37)$$

If the superimposed gradient current u vanishes for $y' = \pm\infty$ the same must apply to u' . It then follows from (36) that u' becomes vanishingly small for very large values of λ' (great depths of the lower layer).

The deformation of the internal boundary is easily computed from (30) and (32), combined into the form

$$\frac{D' - D_o'}{D_o'} = - \frac{1}{f} \frac{du'}{dy'}, \quad (38)$$

which is an expression for the conservation of absolute vorticity in the lower layer.

If it is assumed that the upper layer was at rest before the wind stresses responsible for the gradient current u were applied, it follows that the distortion of the free surface, $h = D + D' - D_0 - D'_0$, must vanish for large positive and negative values of y . Thus it follows from (33) that u must satisfy the requirement

$$\int_{-\infty}^{+\infty} u dy' = 0. \quad (33b)$$

If the superimposed current is symmetric with respect to y it further follows that one must have

$$\int_0^{\infty} u dy' = \int_{-\infty}^0 u dy' = 0. \quad (33c)$$

One must furthermore assume that the deformation of the free surface took place in such a fashion that no mass was added or subtracted. It follows that one must require that

$$\int_{-\infty}^{+\infty} h dy' = \int_{-\infty}^{+\infty} (D + D' - D_o - D_o') dy' = 0. \quad (33d)$$

This last condition is satisfied if u is symmetric and satisfies the condition (33c).

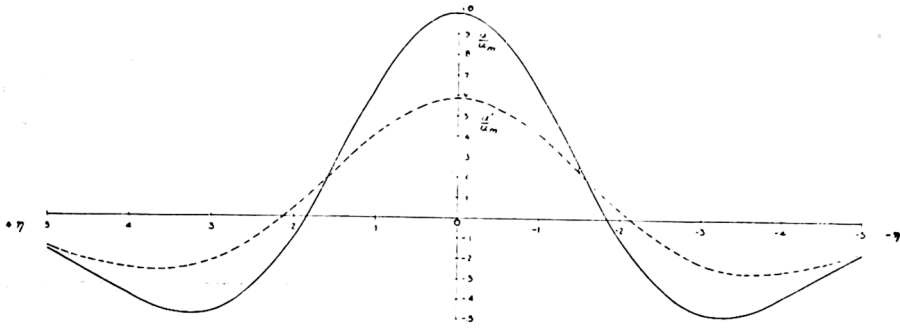

Figure 86. Example of two velocity distributions satisfying equation (36). See text.

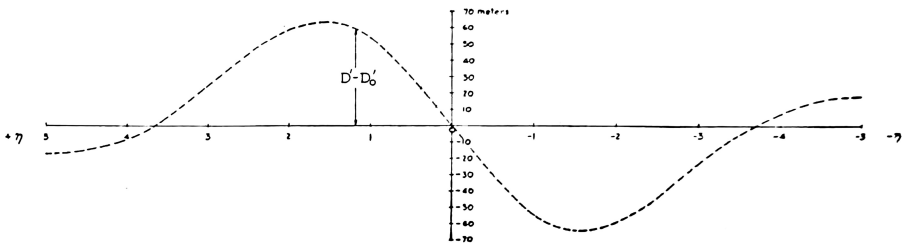

Figure 87. Deformation of the internal boundary. See text.

Figure 86 represents two velocity distributions, u and u' , which satisfy equation (36). The velocity distribution in the upper layer, supposedly established through wind action, is given by

$$\frac{u}{u_m} = \left[1 - \frac{2\beta (1 + 12\beta) \eta^2}{1 + 6\beta} + \frac{8\beta^3 \eta^4}{1 + 6\eta} \right] e^{-\beta \eta^2}, \quad (\lambda' \eta = y') \tag{39}$$

and the corresponding velocity distribution in the lower layer is then

$$\frac{u'}{u_m} = \frac{\rho}{\rho'} \cdot \frac{1}{1 + 6\beta} [1 - 2\beta \eta^2] e^{-\beta \eta^2}. \tag{40}$$

In plotting the curves for $\frac{u'}{u_m}$ and $\frac{u}{u_m}$ it was assumed that $\beta = \frac{1}{9}$.

The deformation of the internal boundary is represented in Figure 87. It follows from (38) that the deflections of the internal boundary will be antisymmetric with respect to y' . In the particular case here investigated the equation for the internal boundary is

$$\frac{D' - D_{o'}}{D_{o'}} = \frac{\rho}{\rho'} \cdot \frac{u_m}{f \lambda'} \cdot \frac{2\beta}{1 + 6\beta} [3 - 2\beta \eta^2] \cdot \eta \cdot e^{-\beta \eta^2} \tag{41}$$

It is apparent from the solution presented above that the internal boundary adjusts itself so as to counteract, in the lower layer, the horizontal pressure gradients transmitted downward from the upper layer, *but it is also evident that this compensation is very incomplete.*

The preceding analysis raises several interesting questions. Most important of these is the following: Will the effect of deformations of the free surface be felt to some extent throughout the entire water column also in case of a continuous variation of density with depth or will the dynamically created solenoids in the interior completely cancel the effect of the surface pressure gradient? It is evident that the usefulness of "dynamic" velocity calculations of non-permanent current patterns to a very large extent depends upon the answer to this question.

We shall attempt to answer this question by a study of the following problem:

An ocean basin of uniform depth is at rest initially. The density decreases at a constant rate upward, from the value ρ_b at the bottom to the value ρ_h at the height h_0 above the bottom. Above this stable layer there is a homogeneous layer of the density ρ_h . Through wind action, or in some other fashion, the free surface is deformed, and a corresponding system of gradient currents set up in the homogeneous water. How do the deep layers react to the new pressure gradients transmitted from above?

We shall assume that the deep water is made up of a very large number of layers of infinitesimal thickness, each one limited above and below by a surface of constant density. Thus each particular layer is enclosed between two isopycnic surfaces, $\rho = \text{constant}$ and $\rho + \delta\rho = \text{constant}$. Within each layer the density may be considered constant and equal to the mean density of the layer ($\rho + 1/2\delta\rho$). Each layer is horizontal before the deformation sets in but is warped during the adjustment process. In the final equilibrium state *horizontal* gradient flow prevails and the motion is thus parallel to the contour lines for that particular layer.

Now consider a chain of particles in one of these isopycnic layers. In the final stage its circulation may be computed from the circulation theorem which, in this particular case, takes the form

$$C = -f(A - A_0), \tag{42}$$

A_0 being the area enclosed by the projection of the chain on a level surface before the deformation, A the corresponding area after the deformation. C is positive for cyclonic circulation.

In the final state horizontal gradient motion prevails. Thus

$$C = \oint u\delta x + v\delta y \tag{43}$$

δx and δy being the components of the horizontal projections of the line elements of the chain. It follows from Stokes' theorem that

$$C = \int \int \left(\frac{\partial v}{\partial x} - \frac{\partial u}{\partial y} \right) \delta x \delta y \tag{44}$$

where $\frac{\partial}{\partial x} \cdot \frac{\partial}{\partial y}$ now represent derivatives with respect to x and y along a constant density surface.

The right side of equation (42) can be written in the form

$$-f \left[\int \int \delta x \delta y - \int \int \delta x_o \delta y_o \right], \quad (45)$$

the subscript 0 referring to the initial state. The equation of continuity gives

$$D = D_o \frac{\partial (x_o, y_o)}{\partial (x, y)} \quad (46)$$

D_o and D representing the vertical thickness of an individual element before and after the deformation. Thus

$$f(A - A_o) = f \int \int \left[1 - \frac{\partial (x_o, y_o)}{\partial (x, y)} \right] \delta x \delta y = f \int \int \frac{D_o - D}{D_o} \delta x \delta y \quad (47)$$

and consequently,

$$\zeta = \frac{\partial v}{\partial x} - \frac{\partial u}{\partial y} = f \frac{D - D_o}{D_o}. \quad (48)$$

ζ is the vertical component of vorticity in the particular isopycnic sheet under study. In the equation (48) $\frac{\partial}{\partial x}$ and $\frac{\partial}{\partial y}$ represent derivatives with to x and y along a surface of constant density.

If $z(x, y, \rho)$ represents the height of a given isopycnic surface after adjustment, $z_o(\rho)$ its initial height, it follows that

$$D = -\frac{\partial z}{\partial \rho} \delta \rho, \quad D_o = -\frac{\partial z_o}{\partial \rho} \delta \rho \quad (49)$$

and thus

$$\zeta = \frac{\partial v}{\partial x} - \frac{\partial u}{\partial y} = f \frac{\frac{\partial z}{\partial \rho} - \frac{\partial z_o}{\partial \rho}}{\frac{\partial z_o}{\partial \rho}}. \quad (50)$$

If one introduces a new measure for the density, defined by

$$r = \frac{\rho_b - \rho}{\rho_b - \rho_h}, \quad \rho_b - \rho_h = 2\kappa \rho_b, \quad \rho = \rho_b (1 - 2\kappa r) \quad (51)$$

it follows that

$$z_o = 0, z = 0, r = 0 \text{ for } \rho = \rho_b \quad (52)$$

$$z_o = h_o, z = h, r = 1 \text{ for } \rho = \rho_h. \quad (53)$$

The assumption is now introduced that the initial vertical density distribution is linear. Thus

$$z_o = h_o r. \tag{54}$$

Substitution in (50) gives

$$\zeta = \frac{\partial v}{\partial x} - \frac{\partial u}{\partial y} = f \frac{\frac{\partial z}{\partial r} - h_o}{h_o}. \tag{55}$$

If one finally introduces the symbol Δ for the vertical departure of each isopycnic surface from its initial position, the law for the conservation of vorticity reduces to the form

$$\zeta = \frac{\partial v}{\partial x} - \frac{\partial u}{\partial y} = \frac{f}{h_o} \frac{\partial \Delta}{\partial r}, \quad \Delta = z - h_o r. \tag{56}$$

The hydrostatic equation must be transformed to include r instead of z as the independent variable, since otherwise the law for the conservation of vorticity cannot be effectively utilized. The pressure at a height z above the bottom is given by

$$p = g \rho_h H + g \int_z^h \rho dz, \tag{57}$$

H being the thickness of the superimposed homogeneous layer. Integration by parts gives

$$p = g \rho_h (h + H) - g \rho z - g \int_p^{\rho_h} z d\rho \tag{58}$$

or

$$p = g \rho_h (h + H) - g \rho z + 2\kappa g \rho_b \int_r^1 z dr. \tag{59}$$

If n represents one of the horizontal coordinates (x or y) and the variation of p along a constant density surface be computed one finds

$$\frac{\partial p}{\partial n} = g \rho_h \frac{\partial (h + H)}{\partial n} - g \rho \frac{\partial z}{\partial n} + 2\kappa g \rho_b \int_r^1 \frac{\partial z}{\partial n} dr. \tag{60}$$

The horizontal variation of any function p in the n -direction and the variation of p with n along a constant density surface are connected through the formula

$$\frac{\partial p}{\partial n} = \left(\frac{\partial p}{\partial n} \right)_z + \frac{\partial p}{\partial z} \frac{\partial z}{\partial n} \tag{61}$$

If p represents the pressure the above formula reduces to

$$\frac{\partial p}{\partial n} = \left(\frac{\partial p}{\partial n} \right)_z - g\rho \frac{\partial z}{\partial n} \quad (62)$$

Thus

$$\left(\frac{\partial p}{\partial n} \right)_z = g\rho_h \frac{\partial}{\partial n} (h + H) + 2\kappa g\rho_b \int_r^1 \frac{\partial z}{\partial n} dr. \quad (63)$$

It follows that gradient current velocities may be computed from

$$\rho f v = g\rho_h \frac{\partial}{\partial x} (h + H) + 2\kappa g\rho_b \int_r^1 \frac{\partial z}{\partial x} dr \quad (64)$$

$$-\rho f u = g\rho_h \frac{\partial}{\partial y} (h + H) + 2\kappa g\rho_b \int_r^1 \frac{\partial z}{\partial y} dr. \quad (65)$$

Disregarding compressibility, the total percentual variation of density along a vertical in the open sea is of the order of magnitude of 0.2 percent. Thus it is entirely permissible to simplify the above equations by setting

$$\frac{\rho_h}{\rho} = \frac{\rho_b}{\rho} = 1. \quad (66)$$

Since z_0 is independent of x and y one finally obtains

$$\frac{f v}{g} = \frac{\partial}{\partial x} (h + H) + 2\kappa \int_r^1 \frac{\partial \Delta}{\partial x} dr \quad (67)$$

$$-\frac{f u}{g} = \frac{\partial}{\partial y} (h + H) + 2\kappa \int_r^1 \frac{\partial \Delta}{\partial y} dr \quad (68)$$

and, for the vorticity,

$$\frac{f \zeta}{g} = \left(\frac{\partial^2}{\partial x^2} + \frac{\partial^2}{\partial y^2} \right) (h + H) + 2\kappa \int_r^1 \left(\frac{\partial^2}{\partial x^2} + \frac{\partial^2}{\partial y^2} \right) \Delta dr. \quad (69)$$

The vertical variation of vorticity is obtained from (69) through differentiation. The result is

$$\frac{\partial \zeta}{\partial r} = -\frac{2\kappa g}{f} \left(\frac{\partial^2}{\partial x^2} + \frac{\partial^2}{\partial y^2} \right) \Delta. \quad (70)$$

Eliminating ζ between (56) and (70) one obtains

$$\boxed{\frac{\partial^2 \Delta}{\partial r^2} + \frac{2\kappa g h_o}{f^2} \left(\frac{\partial^2 \Delta}{\partial x^2} + \frac{\partial^2 \Delta}{\partial y^2} \right) = 0.} \quad (71)$$

There must be continuity in velocity and consequently also in vorticity at the boundary between the homogeneous and the stable water. It follows that ζ is prescribed for the upper boundary ($r = 1$). At the bottom $\Delta = 0$. Thus there is one solution, and one only, which satisfies the requirements of the original problem and the fundamental differential equation (71).

In the case of a parallel current system the preceding equations take a very simple form. It follows from (68) that

$$\frac{\partial u}{\partial r} = \frac{2\kappa g}{f} \frac{\partial \Delta}{\partial y} \tag{72}$$

and from (56) that

$$\frac{\partial u}{\partial y} = - \frac{f}{h_o} \frac{\partial \Delta}{\partial r} \tag{73}$$

If one introduces the radius of deformation λ , defined by

$$\lambda^2 = \frac{2\kappa g h_o}{f^2} \tag{74}$$

it follows that

$$\frac{\partial U}{\partial r} = \frac{\partial Z}{\partial \eta} \tag{75}$$

$$\frac{\partial U}{\partial \eta} = - \frac{\partial Z}{\partial r} \left(y = \lambda \eta, U = \frac{u}{f\lambda}, Z = \frac{\Delta}{h_o} \right). \tag{76}$$

Thus U and Z are conjugate functions, satisfying the equations

$$\left(\frac{\partial^2}{\partial r^2} + \frac{\partial^2}{\partial \eta^2} \right) U = 0, \left(\frac{\partial^2}{\partial r^2} + \frac{\partial^2}{\partial \eta^2} \right) Z = 0. \tag{77}$$

The boundary conditions are:

$$Z = 0 \text{ for } r = 0. \tag{78}$$

$$U \text{ prescribed for } r = 1. \tag{79}$$

The rate at which the current velocity decreases downward is well illustrated by the following case:

The superimposed velocity in the homogeneous layer is given by

$$u_{hom} = u_m \cos k\eta \tag{80}$$

This represents a system of parallel currents of alternating direction, the "wave-length" L being given by

$$L = \frac{2\pi\lambda}{k}, k = \frac{2\pi\lambda}{L}. \tag{81}$$

The corresponding velocity distribution in the interior is given by

$$u = u_m \cdot \frac{e^{kr} + e^{-kr}}{e^k + e^{-k}} \cos k\eta, \quad (82)$$

and the deformation of the individual density surfaces may be computed from

$$\Delta = \frac{h_0}{f\lambda} u_m \cdot \frac{e^{kr} - e^{-kr}}{e^k + e^{-k}} \sin k\eta. \quad (83)$$

The velocity at the bottom (u_b) is given by

$$\frac{u_b}{u_m} = \frac{\cos k\eta}{\cosh k} \quad (84)$$

and the maximum bottom velocity by

$$\frac{u_{b \max}}{u_m} = \frac{1}{\cosh k} = \frac{1}{\cosh \frac{2\pi\lambda}{L}} \quad (85)$$

Thus the effect of the superimposed velocity gradients will extend to greater depths or, which is the same, be more marked at the same depth for a longer "wave-length" L than for a shorter.

The ratio (85) between the maximum bottom velocity and the maximum gradient current velocity has been computed for different values of $n = \frac{L}{\lambda}$. Assuming $h_0 = 1800$ m., $2\kappa = 2 \cdot 10^{-3}$, $g = 10^3$ cm. sec.⁻², $f = 10^{-4}$ sec.⁻¹, one finds

$$\lambda = 60 \text{ km.}$$

The resulting values are given in the line marked $\frac{K_0}{h_0} = 0$ in Table I.

It is evident from these values that the redistribution of mass within a single 1800 m. deep layer of uniform stability is insufficient to reduce a superimposed horizontal surface pressure gradient to zero at the bottom. It appears that for a current width of 240 km. ($L = 480$ km., $n = 8$) the maximum bottom velocity will still be 75% of the maximum gradient velocity of the surface layer. If the total density range and the depth of the stable layer are doubled the value of λ is doubled. The appropriate value of n is reduced to 4, but the maximum bottom velocity is still 40% of the maximum surface velocity. There is no reason to expect such high velocities near the bottom and thus the question concerning the equalization of the horizontal pressure gradients at great depths remains open.

In a further effort to settle this question we shall finally investigate if the presence of another, deep homogeneous layer below the stable water plays an important role in the cancellation of surface pressure gradients through redistribution of mass. It will be assumed that the deep water has a constant density ρ_b and an undisturbed depth K_0 . Then, if Δ_0

Table 1.

$\frac{K_0}{h_0} \backslash n$	0.5	1	2	4	8	16
0	.0000	.0037	.0862	.399	.755	.928
0.5	.0000	.0009	.0337	.232	.605	.855
1	.0000	.0005	.0277	.162	.499	.809
2	.0000	.0003	.0119	.103	.372	.774
∞	0	0	0	0	0	0

represents the deformation of the surface separating the lower homogeneous layer from the stable water above, it follows from the conservation of vorticity in the lower layer and from the requirement of continuity in the velocity distribution that

$$\left(\frac{\partial u}{\partial y}\right)_{r=0} = -\frac{f\Delta_o}{K_o} \tag{88}$$

or,

$$\left(\frac{\partial U}{\partial \eta}\right)_{r=0} = -\frac{h_o}{K_o} \cdot Z_{r=0}. \tag{89}$$

The solution corresponding to the boundary condition (80) and the revised boundary condition (89) is

$$\frac{u}{u_m} = \frac{h_o \cosh kr + kK_o \sinh kr}{h_o \cosh k + kK_o \sinh k} \cos k\eta \tag{90}$$

and

$$\frac{\Delta}{h_o} = \frac{u_m h_o \sinh kr + kK_o \cosh kr}{f\lambda h_o \cosh k + kK_o \sinh k} \sin k\eta. \tag{91}$$

For $K_0 = 0$ these equations become identical with (82) and (83) and for $K_0 \rightarrow \infty$ the solution reduces to

$$\frac{u}{u_m} = \frac{\sinh kr}{\sinh k} \cos k\eta \tag{92}$$

$$\frac{\Delta}{h_o} = \frac{u_m \cosh kr}{f\lambda \sinh k} \sin k\eta. \tag{93}$$

The relation between the maximum velocity in the homogeneous bottom layer and the maximum velocity in the homogeneous surface layer is now obtained by setting $r = 0$ in (90). The result is

$$\begin{aligned} \frac{u_b \max}{u_m} &= \frac{1}{\cosh k \left(1 + \frac{k K_o}{h_o} \tanh k \right)} \\ &= \frac{1}{\cosh \frac{2\pi\lambda}{L} \left(1 + \frac{2\pi\lambda}{L} \cdot \frac{K_o}{h_o} \tanh \frac{2\pi\lambda}{L} \right)}. \end{aligned} \quad (94)$$

For $K_o = 0$ this formula reduces to the one derived previously (85) and for $K_o \rightarrow \infty$ the ratio becomes zero, i.e. the bottom layer will then be at rest. For an initial depth of the lower homogeneous layer of 1800 m. and for the same value of n as before ($n = 8$, $L = 480$ km.) the maximum bottom velocity will still be 50% of the maximum gradient velocity in the upper layer.

The preceding analysis indicates that the effect on the deep water of pressure gradients transmitted from above will be considerably reduced through redistribution of mass in the interior of the ocean, but with reasonable values for the depth and for the total vertical density range there is always a considerable residual effect even in the homogeneous bottom layer. One must conclude that a changing pressure applied on a horizontal surface near the sea surface will be felt also in the bottom water and thus must produce, at least temporarily, sizeable stratospheric currents.

It is obvious that this conclusion does not apply to cases of steady state motion in the ocean, since various frictional forces then have the opportunity to dissipate the kinetic energy of the stratospheric currents. However, the so-called permanent wind systems which actuate the superficial layers of the ocean are changing from day to day and from season to season. It is the author's definite opinion that these changing wind systems must produce deformations of the ocean surface and consequently horizontal pressure gradients which, in the light of the preceding analysis, necessarily must set also the deepest strata in motion. There is no justification whatsoever for the point of view which pictures the ocean stratosphere as completely inert apart from the slow thermal circulation produced by the production of bottom water through cooling in the Antarctic.

Summary

The principal purpose of this investigation is to study those changes in the internal mass distribution which accompany the initial establishment of oceanic current systems through wind stresses applied at the sea surface. Whenever surface water is set in motion through wind action, horizontal pressure gradients are established in the uppermost layers of the ocean. Surrounding and underlying water masses which are not acted upon by the wind, will be set in motion by these new pressures. If, as a first approximation, frictional forces are neglected outside the body of water which is directly influenced by the wind, the displacements and final equilibrium of the surrounding masses may be determined from the requirement that each individual element of water must retain its absolute vorticity. The final

equilibrium thus determined is one of dynamic equilibrium, i.e. characterized by steady motion.

The total energy (potential and kinetic) of the final equilibrium is normally less than the initial energy (kinetic energy received from the wind). The difference goes into inertia oscillations around the final equilibrium state computed from the vorticity theorem mentioned above.

The specific results maybe stated as follows:

1. If, through wind action, an infinite strip of water in an initially motionless homogeneous ocean basin is set in motion in the direction of its own axis, the entire current filament will be deflected to the right of the downstream direction⁴ as a result of the initially unbalanced Coriolis' force associated with its momentum. The sea surface will rise along the right edge, fall along the left edge, until a transversal pressure gradient (slope) is established which exactly balances the Coriolis' force. The rise (drop) of the sea surface in the environment of the current may be computed from the requirement that each vertical column of water must conserve its absolute vorticity.
2. The sum of the potential and kinetic energy in this equilibrium state is somewhat less than the initial kinetic energy of the system (there is no potential energy in the initial state). The difference in energy goes into an inertia oscillation with a period of twelve pendulum hours. As a result of this inertia oscillation the deflection of the current will proceed beyond the equilibrium position and then reverse direction. However, in a homogeneous ocean the fraction of energy stored in this inertia oscillation is small.
3. If, through wind action, an infinite strip of water in the upper of two homogeneous layers is set in motion in the direction of its own axis, a similar adjustment process occurs. While the free surface rises along the right edge, sinks along the left edge of the current, the internal boundary will be deformed in the opposite sense. If the lower layer is very deep it is permissible to assume that it will be practically motionless also after completed adjustment. The ratio of the deformation of the free surface to that of the internal boundary then has the same value as the ratio of the difference in density between the two layers to the density of the upper layer. In this case the total deflection of the current system is increased several times over the corresponding deflection in a homogeneous ocean.
4. In such a double-layer ocean with a resting bottom layer the fraction of the initial energy which goes into inertia oscillations is many times larger than in a homogeneous ocean.
5. The adjustment to equilibrium of the initially unbalanced current filament is in both cases accompanied by the development of counter currents in the environment. These

4. On the northern hemisphere.

counter currents are very weak and broad in the case of a homogeneous ocean but narrow and intense in the case of a double-layer ocean.

6. The shear zones between the current and its environment are known to be dynamically unstable and should therefore have a tendency to break up into large-scale horizontal eddies (lateral turbulence).
7. Since there is a much greater supply of energy available for vigorous inertia oscillations in a double-layer ocean than in a homogeneous ocean, it is reasonable to assume that lateral turbulence must be more strongly developed in stratified than in homogeneous water; this conclusion strongly supports Parr's suggestion concerning the relation between lateral eddy viscosity and vertical stability.
8. In a stratified ocean the momentum received from the wind will be distributed over a shallow vertical column, whereas it will be spread over a much deeper column in homogeneous water. For this reason strong unbalanced current components are more likely to occur in stratified than in homogeneous water. This would tend to produce stronger inertia oscillations, and hence presumably stronger lateral turbulence, in stratified water than in homogeneous, again in agreement with the suggested relationship between lateral turbulence and vertical stability.
9. If the lower of the two layers in the idealized ocean referred to above has a finite depth, the displacement of the upper unbalanced current towards its equilibrium position will be accompanied by a transversal displacement of the lower layer in the opposite direction. This displacement below will, as a result of the Coriolis' acceleration, lead to the development of a gradient current in the lower layer in the same direction as the initial current in the upper layer. Thus, although the internal boundary between the two layers is deformed in such a fashion as to counteract the pressure gradients associated with the deformations of the free surface, it may be stated that it is normally impossible to superimpose a horizontal pressure gradient at the ocean surface without having its effect temporarily transmitted all the way to the bottom layer.
10. This result is further analyzed in the case of an ocean consisting of an upper, homogeneous layer and a lower stable layer with an initially linear density distribution. It is assumed that a prescribed horizontal pressure distribution (perturbation pressure) is established in a geopotential surface within the upper homogeneous layer. Assuming that each infinitesimal isopycnic layer in the stable water conserves its absolute vorticity, it is possible to determine the final equilibrium state. It is found that sizeable gradient currents normally must develop also next to the bottom.
11. The percentual rate at which a prescribed perturbation pressure at the surface is equalized with increasing depth in an ocean basin of normal stability depends upon the lateral dimensions of the superimposed perturbation. A superimposed gradient current system in the upper homogeneous layer with a width of a few kilometers will hardly be felt at the bottom of the stratified layer (assumed to have a depth of 1 800 m), but if the superimposed current has a width of between two and three

hundred kilometers the horizontal pressure gradient at the bottom will still be about one half of the surface pressure gradient.

12. If there is a deep layer of homogeneous water also below the stable layer the gradient currents next to the bottom will be further reduced, but it still appears that sizeable gradient currents must develop in the bottom water whenever the horizontal pressure distribution in the homogeneous water near the surface changes over reasonably wide areas.
13. The preceding conclusions regarding the motion of the bottom water do *not* apply to a perfectly steady state of motion in the ocean. However, since the large atmospheric wind systems which drive the ocean circulation change from day to day and from season to season it is permissible to state with a reasonable degree of assurance, that it is entirely inappropriate to consider the homogeneous bottom water as inert beyond the slow thermal circulation maintained by antarctic cooling.
14. It is in particular unjustifiable to assume à priori that the velocity distribution within larger non-permanent current patterns (such as the larger of those eddies which form intermittently along the edges of the permanent current systems) may be computed on the basis is that there is no motion in the deep water.

REFERENCES

- Ekman, V. W. 1905. On the influence of the earth's rotation on ocean-currents. *Arkiv. für Matematik, Astronomi och Fysik*, 2(11), 1–52.
- Parr, A. E. 1936. On the probable relationship between vertical stability and lateral mixing processes. *J. du Conseil*, 11(3), 308–313.
- Pekeris, C. L. 1938. Wave distribution in a homogeneous current. *Transactions of the American Geographical Union*, 20, 163–164.
- Rossby, C.-G. 1937. On the mutual adjustment of pressure and velocity distribution in certain simple current systems. *J. Mar. Res.*, 1(1), 15–28.
- Svedrup, H. U. 1938. On the process of upwelling, *J. Mar. Res.*, 1(2), 155–164.