

Yale University

## EliScholar – A Digital Platform for Scholarly Publishing at Yale

---

YPFS Documents

[Browse by Media Type](#)

---

2-1-2012

### Federal Reserve Bank of New York Staff Reports on Shadow Banking

Pozsar Zoltan

Follow this and additional works at: <https://elischolar.library.yale.edu/ypfs-documents>

---

#### Recommended Citation

Zoltan, Pozsar, "Federal Reserve Bank of New York Staff Reports on Shadow Banking" (2012). *YPFS Documents*. 548.

<https://elischolar.library.yale.edu/ypfs-documents/548>

This Document is brought to you for free and open access by the Browse by Media Type at EliScholar – A Digital Platform for Scholarly Publishing at Yale. It has been accepted for inclusion in YPFS Documents by an authorized administrator of EliScholar – A Digital Platform for Scholarly Publishing at Yale. For more information, please contact [elischolar@yale.edu](mailto:elischolar@yale.edu).

Federal Reserve Bank of New York  
Staff Reports

# Shadow Banking

Zoltan Pozsar  
Tobias Adrian  
Adam Ashcraft  
Hayley Boesky

Staff Report No. 458  
July 2010  
*Revised February 2012*



This paper presents preliminary findings and is being distributed to economists and other interested readers solely to stimulate discussion and elicit comments. The views expressed in this paper are those of the authors and are not necessarily reflective of views at the Federal Reserve Bank of New York or the Federal Reserve System. Any errors or omissions are the responsibility of the authors.

## **Shadow Banking**

Zoltan Pozsar, Tobias Adrian, Adam Ashcraft, and Hayley Boesky

Federal Reserve Bank of New York Staff Reports, no. 458

July 2010; revised February 2012

JEL classification: G20, G28, G01

### **Abstract**

The rapid growth of the market-based financial system since the mid-1980s changed the nature of financial intermediation. Within the market-based financial system, “shadow banks” have served a critical role. Shadow banks are financial intermediaries that conduct maturity, credit, and liquidity transformation without explicit access to central bank liquidity or public sector credit guarantees. Examples of shadow banks include finance companies, asset-backed commercial paper (ABCP) conduits, structured investment vehicles (SIVs), credit hedge funds, money market mutual funds, securities lenders, limited-purpose finance companies (LPFCs), and the government-sponsored enterprises (GSEs). Our paper documents the institutional features of shadow banks, discusses their economic roles, and analyzes their relation to the traditional banking system. Our description and taxonomy of shadow bank entities and shadow bank activities are accompanied by “shadow banking maps” that schematically represent the funding flows of the shadow banking system.

Key words: shadow banking, financial intermediation

---

Adrian, Ashcraft: Federal Reserve Bank of New York. Pozsar: International Monetary Fund. Boesky: Bank of America Merrill Lynch. Address correspondence to Tobias Adrian (e-mail: [tobias.adrian@ny.frb.org](mailto:tobias.adrian@ny.frb.org)). The views expressed in this paper are those of the authors and do not necessarily reflect the position of the Federal Reserve Bank of New York or the Federal Reserve System.

# The Shadow Banking System

Conceptualized, designed and created by Zoltan Pozsar ([zoltan.pozsar@ny.frb.com](mailto:zoltan.pozsar@ny.frb.com))  
The Federal Reserve Bank of New York, November, 2009

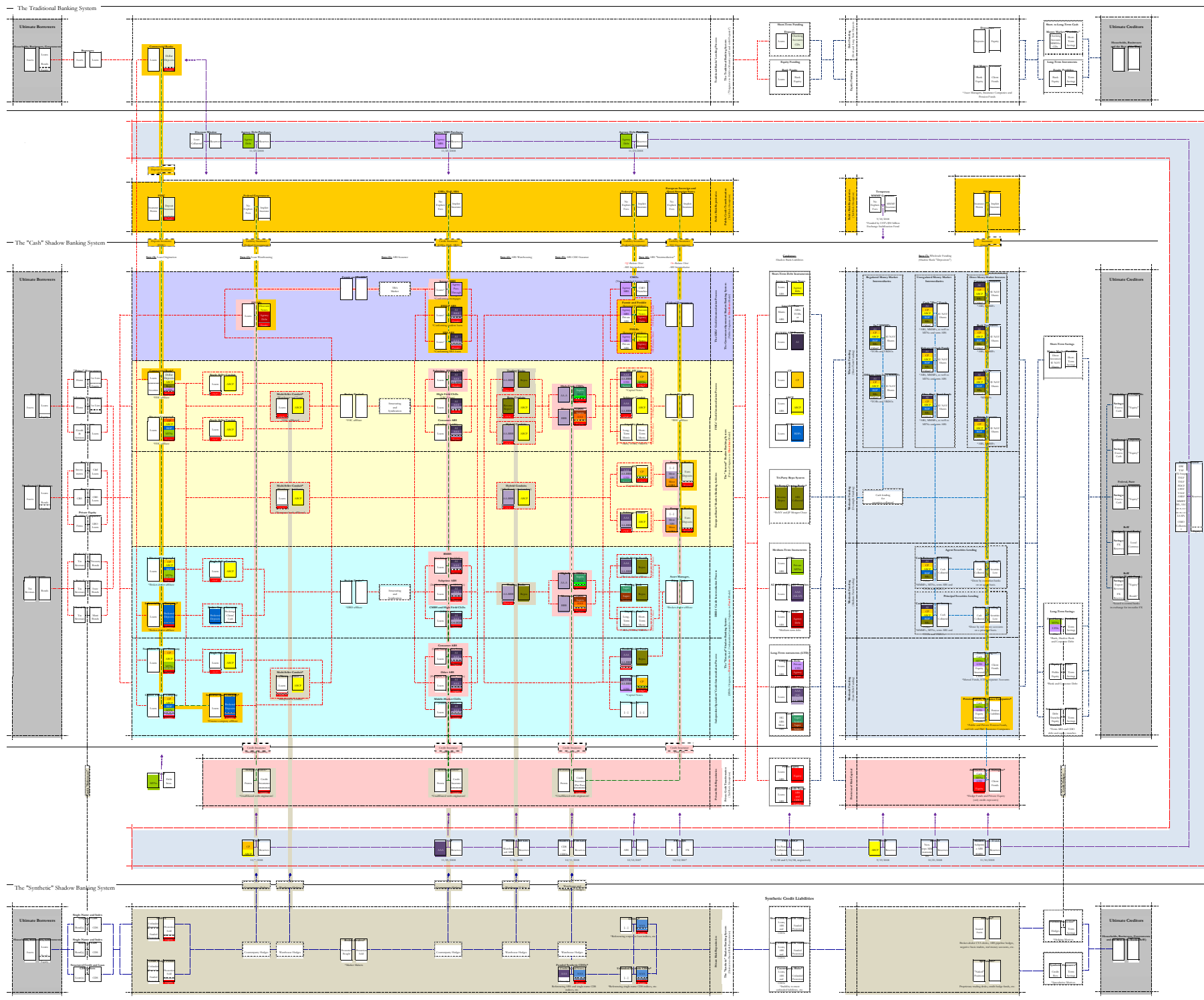

## 1. Introduction

Shadow banks intermediate credit through a wide range of securitization and secured funding techniques such as asset-backed commercial paper (ABCP), asset-backed securities (ABS), collateralized debt obligations (CDOs) and repurchase agreements (repos). These securities are used by specialized shadow bank intermediaries that are bound together along an intermediation chain. We refer to the network of shadow banks in this intermediation chain as the shadow banking system. While we believe that shadow banking is a somewhat pejorative name for such a large and important part of the financial system, we adopt it in this paper.

Over the past decade, the shadow banking system provided sources of funding for credit by converting opaque, risky, long-term assets into money-like, short-term liabilities. Arguably, maturity and credit transformation in the shadow banking system contributed to the asset price appreciation in residential and commercial real estate markets prior to the 2007-09 financial crisis. During the financial crisis, the shadow banking system became severely strained and many parts of the system collapsed. Credit creation through maturity, credit, and liquidity transformation can significantly reduce the cost of credit relative to direct lending. However, credit intermediaries' reliance on short-term liabilities to fund illiquid long-term assets is an inherently fragile activity and may be prone to runs.<sup>1</sup> As the failure of credit intermediaries can have large, adverse effects on the real economy (see Bernanke (1983) and Ashcraft (2005)), governments chose to shield them from the risks inherent in reliance on short-term funding by granting them access to liquidity and credit put options in the form of discount window access and deposit insurance, respectively.

---

<sup>1</sup> There is a large literature on bank runs modeled as multiple equilibria initiated by Diamond and Dybvig (1983). Morris and Shin (2004) provide a model of funding fragility with a unique equilibrium in a setting with higher order beliefs. Martin, Skeie and von Thadden (2011) provide a theory of runs in the repo market.

Shadow banks conduct credit, maturity and liquidity transformation similar to traditional banks. However, what distinguishes shadow banks from traditional banks is their lack of access to public sources of liquidity such as the Federal Reserve's discount window, or public sources of insurance such as Federal Deposit Insurance. The emergency liquidity facilities launched by the Federal Reserve and other government agencies' guarantee schemes created during the financial crisis were direct responses to the liquidity and capital shortfalls of shadow banks. These facilities effectively provided a backstop to credit intermediation by the shadow banking system and to traditional banks for their exposure to shadow banks.

In contrast to public-sector guarantees of the traditional banking system, prior to the onset of the financial crisis of 2007-2009, the shadow banking system was presumed to be safe due to liquidity and credit puts provided by the private sector. These puts underpinned the perceived risk-free, highly liquid nature of most AAA-rated assets that collateralized credit repos and shadow banks' liabilities more broadly. However, once private sector put providers' solvency was questioned, even if solvency was perfectly satisfactory in some cases, the confidence that underpinned the stability of the shadow banking system vanished. The run on the shadow banking system, which began in the summer of 2007 and peaked following the failure of Lehman in September and October 2008, was stabilized only after the creation of a series of official liquidity facilities and credit guarantees that replaced private sector guarantees entirely. In the interim, large portions of the shadow banking system were eroded.

The failure of private sector guarantees to support the shadow banking system stemmed largely from the underestimation of asset price correlations by every relevant party: credit rating agencies, risk managers, investors, and regulators. Specifically, they did not account for the fact that the prices of highly rated structured securities become much more correlated in extreme environments than in

normal times. In a major systemic event, the price behavior of diverse assets become highly correlated as investors and levered institutions are forced to shed assets in order to generate the liquidity necessary to meet margin calls (see Coval, Jurek and Stafford (2009)). Mark-to-market leverage constraints result in pressure on market-based balance sheets (see Adrian and Shin (2010a), and Geanakoplos (2010)). The underestimation of correlation enabled financial institutions to hold insufficient amounts of liquidity and capital against the puts that underpinned the stability of the shadow banking system, which made these puts unduly cheap to sell. As investors also overestimated the value of private credit and liquidity enhancement purchased through these puts, the result was an excess supply of cheap credit.

The AAA assets and liabilities that collateralized and funded the shadow banking system were the product of a range of securitization and secured lending techniques. Securitization-based credit intermediation process has the potential to increase the efficiency of credit intermediation. However, securitization-based credit intermediation also creates agency problems which do not exist when these activities are conducted within a bank. In fact, Ashcraft and Schuermann (2007) document seven agency problems that arise in the securitization markets. If these agency problems are not adequately mitigated with effective mechanisms, the financial system has weaker defenses against the supply of poorly underwritten loans and aggressively structured securities.

Overviews of the shadow banking system are provided by Pozsar (2008) and Adrian and Shin (2009). Pozsar (2008) catalogues different types of shadow banks and describes the asset and funding flows within the shadow banking system. Adrian and Shin (2009) focus on the role of security brokers and dealers in the shadow banking system, and discuss implications for financial regulation. The term “shadow banking” was coined by McCulley (2007). Gertler and Boyd (1993)

and Corrigan (2000) are early discussions of the role of commercial banks and the market based financial system in financial intermediation.

The contribution of the current paper is to focus on institutional details of the shadow banking system, complementing a rapidly growing literature on the system's collapse.. As such, our paper is primarily descriptive, and focuses on funding flows in a somewhat mechanical manner. We believe that the understanding of the plumbing of the shadow banking system is an important underpinning of any study of systemic interlinkages within the financial system.

The remainder of the paper is organized as follows. Section 2 provides a definition of shadow banking, and an estimate of the size of shadow banking activity. Section 3 discusses the seven steps of the shadow credit intermediation process. Section 4 is by far the longest section of the paper, describing the interaction of the shadow banking system with institutions such as bank holding companies and broker dealers. Finally, section 5 concludes.

## **2. WHAT IS SHADOW CREDIT INTERMEDIATION?**

### **2.1 Defining Shadow Banking**

In the traditional banking system, intermediation between savers and borrowers occurs in a single entity. Savers entrust their savings to banks in the form of deposits, which banks use to fund the extension of loans to borrowers. Savers furthermore own the equity and debt issuance of the banks. Relative to direct lending (that is, savers lending directly to borrowers), credit intermediation provides savers with information and risk economies of scale by reducing the costs involved in screening and monitoring borrowers and by facilitating investments in a more diverse loan portfolio.



Credit intermediation involves credit, maturity, and liquidity transformation. Credit transformation refers to the enhancement of the credit quality of debt issued by the intermediary through the use of priority of claims. For example, the credit quality of senior deposits is better than the credit quality of the underlying loan portfolio due to the presence of junior equity. Maturity transformation refers to the use of short-term deposits to fund long-term loans, which creates liquidity for the saver but exposes the intermediary to rollover and duration risks. Liquidity transformation refers to the use of liquid instruments to fund illiquid assets. For example, a pool of illiquid whole loans might trade at a lower price than a liquid rated security secured by the same loan pool, as certification by a credible rating agency would reduce information asymmetries between borrowers and savers.

Credit intermediation is frequently enhanced through the use of third-party liquidity and credit guarantees, generally in the form of liquidity or credit put options. When these guarantees are provided by the public sector, credit intermediation is said to be officially enhanced. For example, credit intermediation performed by depository institutions is enhanced by credit and liquidity put options provided through deposit insurance and access to central bank liquidity, respectively.

Exhibit 1 lays out the framework by which we analyze official enhancements.<sup>2</sup> Thus, official enhancements to credit intermediation activities have four levels of “strength” and can be classified as either direct or indirect, and either explicit or implicit.

1. A liability with direct official enhancement must reside on a financial institution’s balance sheet, while off-balance sheet liabilities of financial institutions are indirectly enhanced by the public sector. Activities with direct and explicit official enhancement include on-balance sheet funding

---

<sup>2</sup> The analysis of deposit insurance was formally analyzed by Merton (1977) and Merton and Bodie (1993).

of depository institutions; insurance policies and annuity contracts; the liabilities of most pension funds; and debt guaranteed through public-sector lending programs.<sup>3</sup>

2. Activities with direct and implicit official enhancement include debt issued or guaranteed by the government sponsored enterprises, which benefit from an implicit credit put to the taxpayer.
3. Activities with indirect official enhancement generally include for example the off-balance sheet activities of depository institutions like unfunded credit card loan commitments and lines of credit to conduits.
4. Finally, activities with indirect and implicit official enhancement include asset management activities such as bank-affiliated hedge funds and money market mutual funds, and securities lending activities of custodian banks. While financial intermediary liabilities with an explicit enhancement benefit from official sector puts, liabilities enhanced with an implicit credit put option might not benefit from such enhancements ex post.

In addition to credit intermediation activities that are enhanced by liquidity and credit puts provided by the public sector, there exist a wide range of credit intermediation activities which take place without official credit enhancements. These credit intermediation activities are said to be unenhanced. For example, the securities lending activities of insurance companies, pension funds and certain asset managers do not benefit from access to official liquidity.

We define shadow credit intermediation to include all credit intermediation activities that are implicitly enhanced, indirectly enhanced or unenhanced by official guarantees (points 2.), 3.) and 4.) from above).

---

<sup>3</sup> Depository institutions, including commercial banks, thrifts, credit unions, federal savings banks and industrial loan companies, benefit from federal deposit insurance and access to official liquidity backstops from the discount window. Insurance companies benefit from guarantees provided by state guaranty associations. Defined benefit private pensions benefit from insurance provided by the Pension Benefit Guaranty Corporation (PBGC), and public pensions benefit from implicit insurance provided by their state, municipal, or federal sponsors. The Small Business Administration, Department of Education, and Federal Housing Administration each operate programs that provide explicit credit enhancement to private lending.

Exhibit 1: The Topology of Pre-Crisis Shadow Banking Activities and Shadow Bank Liabilities

Institution	Direct Public Enhancement		Indirect Public Enhancement		Unenhanced
	Explicit	Implicit	Explicit	Implicit	
<b>Depository Institutions</b> <i>(Commercial Banks, Clearing Banks, LLCs)</i>	Insured deposits <sup>1</sup> Non-deposit liabilities <sup>2</sup>		Credit lines to shadow banks <sup>9</sup>	Trust activities Tri-party clearing <sup>10</sup> Asset management Affiliate borrowing	
<b>Federal Loan Programs</b> <i>(DoE, SBA and FHA credit puts)</i>	Loan guarantees <sup>3</sup>				
<b>Government Sponsored Enterprises</b> <i>(Fannie Mae, Freddie Mac, FHLBs)</i>		Agency debt	Agency MBS		
<b>Insurance Companies</b>	Annuity liabilities <sup>4</sup> Insurance policies <sup>5</sup>				Securities lending CDS protection sold
<b>Pension Funds</b>	Unfunded liabilities <sup>6</sup>				Securities lending
<b>Diversified Broker-Dealers</b> <i>(Investment Bank Holding Companies)</i>	Brokered deposits (ILCs) <sup>7</sup>		CP <sup>11</sup>	Tri-party repo <sup>12</sup>	MTNs Prime brokerage customer balances Liquidity puts (ABS, TOB, VRDO, ARS)
<b>Mortgage Insurers</b>					Financial guarantees
<b>Monoline Insurers</b>					Financial guarantees CDS protection sold on CDOs Asset management (GICs, SIVs, conduits)
<b>Shadow Banks</b>  Finance Companies (Standalones, Captives) Single-Seller Conduits Multi-Seller Conduits Hybrid Conduits TRS/Repo Conduits Securities Arbitrage Conduits Structured Investment Vehicles (SIVs) Limited Purpose Finance Companies Credit Hedge Funds (Standalones)	Brokered deposits (ILCs) <sup>7</sup>		CP <sup>11</sup> ABCP <sup>13</sup> ABCP <sup>13</sup> ABCP <sup>13</sup> ABCP <sup>13</sup> ABCP <sup>13</sup> ABCP <sup>13</sup> ABCP <sup>13</sup> Bi-lateral repo <sup>14</sup> Bi-lateral repo <sup>14</sup>	Extendible ABCP <sup>17</sup> Extendible ABCP <sup>17</sup> Extendible ABCP <sup>17</sup> MTNs, capital notes	Term ABS, MTNs Extendible ABCP <sup>18</sup> Extendible ABCP <sup>18</sup> Extendible ABCP <sup>18</sup> Extendible ABCP <sup>18</sup> Extendible ABCP <sup>18</sup> Extendible ABCP <sup>18</sup> MTNs, capital notes Bi-lateral repo <sup>15</sup> Bi-lateral repo <sup>15</sup>
<b>Money Market Intermediaries</b> <i>(Shadow Bank "Depositors")</i> Money Market Mutual Funds Overnight Sweep Agreements Cash "Plus" Funds Enhanced Cash Funds Ultra-Short Bond Funds Local Government Investment Pools (LGIPs) Securities Lenders					\$1 NAV \$1 NAV \$1 NAV \$1 NAV \$1 NAV \$1 NAV \$1 NAV
<b>European Banks</b> <i>(Landeshbanks, etc.)</i>	State guarantees <sup>8</sup>	ABCP <sup>16</sup>	Credit lines to shadow banks <sup>17</sup>		

Source: Shadow Banking (Pozsar, Adrian, Ashcraft, Boesky (2010))

## 2.2 Sizing the Shadow Banking System

Before describing the shadow intermediation process in detail, we begin by reporting a gauge of the size of shadow banking activity. Figure 1 provides two measures of the shadow banking system, net and gross, both computed from the Federal Reserve Board's flow of funds. The gross measure sums all liabilities recorded in the flow of funds that relate to securitization activity (MBS, ABS, and other GSE liabilities), as well as all short term money market transactions that are not backstopped

by deposit insurance (repos, commercial paper, and other money market mutual fund liabilities). The net measure attempts to remove the double counting.

**Figure 1:** Shadow Bank Liabilities vs. Traditional Bank Liabilities, \$ trillion<sup>4</sup>

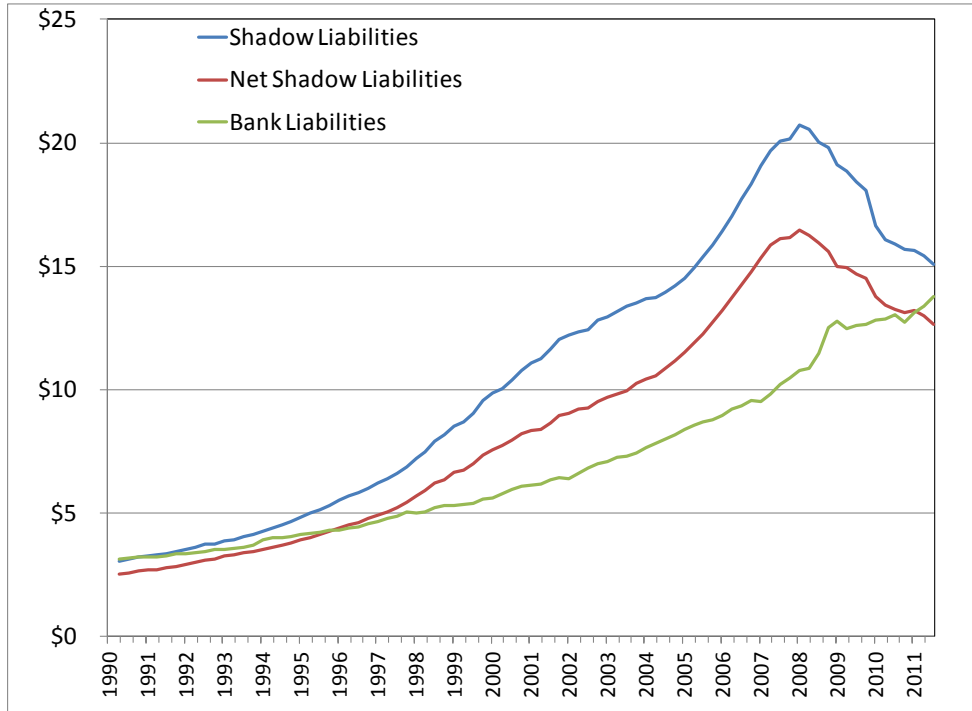

**Source:** Flow of Funds Accounts of the United States as of 2011:Q3 (FRB) and FRBNY.

We should point out that these measures of the shadow banking system are imperfect for several reasons. First, the flow of funds does not cover the transactions of all shadow banking entities (see Eichner, Kohn and Palumbo (2010) for data limitations of the flow of funds in detecting the imbalances that built up prior to the financial crisis). Second, we are not providing a measure of the net supply of credit of shadow banks to the real economy. In fact, the gross number is summing up all shadow banking liabilities, irrespective of double counting. The gross number should not be

<sup>4</sup> The chart uses data from the Flow of Funds Accounts of the United States. Traditional liabilities refer to the Total Liabilities of Commercial Banking reported in line 19 of Table L109, which includes U.S.-chartered commercial banks, foreign banking offices in U.S., bank holding companies, and banks in U.S.-affiliated areas. Shadow Liabilities refer to the sum of Open Market Paper from line 1 of Table L208, Overnight Repo from FRBNY, Net Securities Lending from line 20 of Table L130, GSE Total Liabilities from line 21 of Table L124, GSE Total Pool Securities from line 6 of Table L125, Total Liabilities of ABS issuers from line 11 of Table L126, and Total Shares Outstanding of Money Market Mutual Funds from line 13 of Table L121.

interpreted as a proxy for the net supply of credit by shadow banks, but rather as the gross total of securities relating to shadow banking activities. The net number mitigates the second problem by netting the money market funding of ABS and MBS. However, the net measure is not a measure of the net supply of credit relating provided by shadow banking activities for many reasons. Third, many of the securitized assets are held on the balance sheets of traditional depository and insurance institutions, or supported off their balance sheets through backup liquidity and credit derivative or reinsurance contracts. The holding of shadow liabilities by institutions inside the safety net makes it difficult to draw bright lines between the traditional and shadow credit intermediation, and prompting us to classify the latter at the instrument and not institution level.

As illustrated in Figure 1, the gross measure of shadow bank liabilities grew to a size of nearly \$22 trillion in June 2007. We also plot total traditional banking liabilities in comparison, which were around \$14 trillion in 2007.<sup>5</sup> The size of the shadow banking system has contracted substantially since the peak in 2007. In comparison, total liabilities of the banking sector have continued to grow throughout the crisis. The governmental liquidity facilities and guarantee schemes introduced since the summer of 2007 helped ease the \$5 trillion contraction in the size of the shadow banking system, thereby protecting the broader economy from the dangers of a collapse in the supply of credit as the financial crisis unfolded. While these programs were only temporary in nature, given the still significant size of the shadow banking system and its inherent fragility due to exposure to runs by wholesale funding providers, one open question is the extent to which some shadow banking activities should have more permanent access to official backstops, and increased oversight, on a more permanent basis.

---

<sup>5</sup> Adrian and Shin (2010b) and Brunnermeier (2009) provide complementary overviews of the financial system in light of the financial crisis.

### 3. THE SHADOW CREDIT INTERMEDIATION PROCESS

The shadow banking system is organized around securitization and wholesale funding. In the shadow banking system, loans, leases, and mortgages are securitized and thus become tradable instruments. Funding is also in the form of tradable instruments, such as commercial paper and repo. Savers hold money market balances, instead of deposits with banks.

Like the traditional banking system, the shadow banking system conducts credit intermediation. However, unlike the traditional banking system, where credit intermediation is performed “under one roof”—that of a bank—in the shadow banking system, it is performed through a daisy-chain of non-bank financial intermediaries in a multi step process. These steps entail the “vertical slicing” of traditional banks’ credit intermediation process and include (1) loan origination, (2) loan warehousing, (3) ABS issuance, (4) ABS warehousing, (5) ABS CDO issuance, (6) ABS “intermediation” and (7) wholesale funding. The shadow banking system performs these steps of shadow credit intermediation in a strict, sequential order with each step performed by a specific type of shadow bank and through a specific funding technique.

1. *Loan origination* (i.e. auto loans and leases, non-conforming mortgages, etc.) is performed by finance companies which are funded through commercial paper (CP) and medium-term notes (MTNs).
2. *Loan warehousing* is conducted by single- and multi-seller conduits and is funded through asset-backed commercial paper (ABCP).
3. *The pooling and structuring of loans into term asset-backed securities (ABS)* is conducted by broker-dealers’ ABS syndicate desks.
4. *ABS warehousing* is facilitated through trading books and is funded through repurchase agreements (repo), total return swaps or hybrid and repo/TRS conduits.

5. *The pooling and structuring of ABS into CDOs* is also conducted by broker-dealers' ABS syndicate desks.
6. *ABS intermediation* is performed by limited purpose finance companies (LPFCs), structured investment vehicles (SIVs), securities arbitrage conduits and credit hedge funds, which are funded in a variety of ways including for example repo, ABCP, MTNs, bonds and capital notes.
7. The *funding* of all the above activities and entities is conducted in wholesale funding markets by funding providers such as regulated and unregulated money market intermediaries (for example, 2(a)-7 MMMFs and enhanced cash funds, respectively) and direct money market investors (such as securities lenders). In addition to these *cash* investors, which fund shadow banks through short-term repo, CP and ABCP instruments, fixed income mutual funds, pension funds and insurance companies also fund shadow banks by investing in their longer-term MTNs and bonds.

**Exhibit 2: The Steps, Entities and Funding Techniques Involved in Shadow Credit Intermediation - Illustrative Examples**

	Function	Shadow Banks	Shadow Banks' Funding*
<b>Step (1)</b>	Loan Origination	Finance companies	CP, MTNs, bonds
<b>Step (2)</b>	Loan Warehousing	Single and multi-seller conduits	ABCP
<b>Step (3)</b>	ABS Issuance	SPVs, structured by broker-dealers	ABS
<b>Step (4)</b>	ABS Warehousing	Hybrid, TRS/repo conduits, broker-dealers' trading books	ABCP, repo
<b>Step (5)</b>	ABS CDO Issuance	SPVs, structured by broker-dealers	ABS CDOs, CDO-squareds
<b>Step (6)</b>	ABS Intermediation	LPFCs, SIVs, securities arbitrage conduits, credit hedge funds	ABCP, MTN, repo
<b>Step (7)</b>	Wholesale Funding	2(a)-7 MMMFs, enhanced cash funds, securities lenders, etc	\$1 NAV shares (shadow bank "deposits")

\*Funding types highlighted in red denote securitized funding techniques. Securitized funding techniques are *not* synonymous with secured funding.

Source: Shadow Banking (Pozsar, Adrian, Ashcraft, Boesky (2010))

The shadow credit intermediation process conducts an economic role that is analogous to the credit intermediation process performed by banks in the traditional banking system. The shadow banking system decomposes the simple process of deposit-funded, hold-to-maturity lending conducted by banks into a more complex, wholesale-funded, securitization-based lending process. Through this intermediation process, the shadow banking system transforms risky, long-term loans (subprime

mortgages, for example) into seemingly credit-risk free, short-term, money-like instruments, stable net asset value (NAV) shares that are issued by 2(a)-7 money market mutual funds which require daily liquidity. This crucial point is illustrated by the first and last links in Exhibit 3 depicting the asset and funding flows of the credit intermediation process of the shadow banking system.

Exhibit 3: The Shadow Credit Intermediation Process

The shadow credit intermediation process consists of distinct steps. These steps for a credit intermediation chain that depending on the type and quality of credit involved may involve as little as 3 steps and as much as 7 or more steps. The shadow banking system conducts these steps in a strict sequential order. Each step is conducted by specific types of financial entities, which are funded by specific types of liabilities (see Table 2).

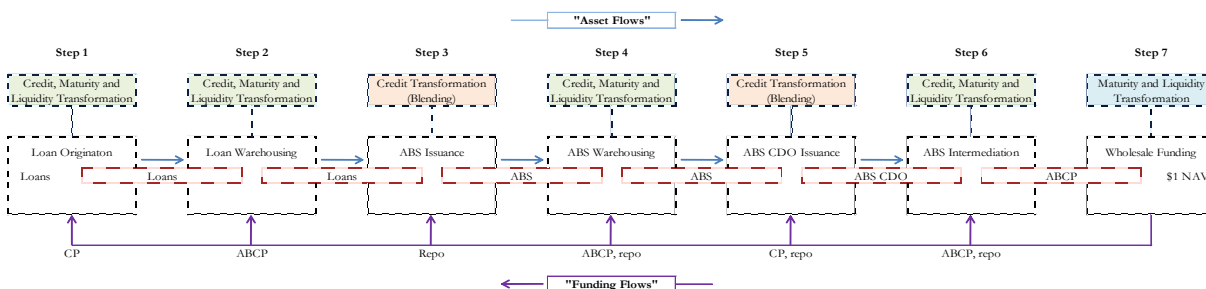

Source: Shadow Banking (Pozsar, Adrian, Ashcraft, Boesky (2010))

Importantly, not all intermediation chains involve all seven steps, and some might involve even more steps. For example, an intermediation chain might stop at “Step 2” if a pool of prime auto loans is sold by a captive finance company to a bank-sponsored multi-seller conduit for term warehousing purposes. In another example, ABS CDOs could be further repackaged into a CDO<sup>2</sup>, which would elongate the intermediation chain to include eight steps. Typically, the poorer an underlying loan pool’s quality at the beginning of the chain (for example a pool of subprime mortgages originated in California in 2006), the longer the credit intermediation chain that would be required to “polish” the quality of the underlying loans to the standards of money market mutual funds and similar funds. As a rule of thumb, the intermediation of low-quality long-term loans (non-conforming mortgages) involved all seven or more steps, whereas the intermediation of high-quality short- to medium-term loans (credit card and auto loans) involved usually three steps (and rarely more). The intermediation chain always starts with origination and ends with wholesale funding, and each shadow bank appears only once in the process.



## 4. THE SHADOW BANKING SYSTEM

We identify the three distinct subgroups of the shadow banking system. These are: (1) the government-sponsored shadow banking sub-system; (2) the “internal” shadow banking sub-system; and (3) the “external” shadow banking sub-system. We also discuss the liquidity backstops that were put in place during the financial crisis.

### 4.1 The Government-Sponsored Shadow Banking Sub-System

The seeds of the shadow banking system were sown nearly 80 years ago, with the creation the government-sponsored enterprises (GSE), which are comprised of the FHLB system (1932), Fannie Mae (1938) and Freddie Mac (1970). The GSEs have dramatically impacted the way in which banks fund are funded and conduct credit transformation: the FHLBs were the first providers of term warehousing of loans, and Fannie Mae and Freddie Mac were cradles of the originate-to-distribute model of securitized credit intermediation.

**Exhibit 4: The Steps, Entities and Funding Techniques Involved in the GSEs' Credit Intermediation Process**

	Function	Shadow Banks	Shadow Banks' Funding*
Step (1)	Mortgage Origination	Commercial banks	Deposits, CP, MTNs, bonds
Step (2)	Mortgage Warehousing	FHLBs	Agency debt and discount notes
Step (3)	ABS Issuance	Fannie Mae, Freddie Mac through the TBA market	Agency MBS (passthroughs)
Step (4)	ABS Warehousing	Broker-dealers' trading books	ABCP, repo
Step (5)	ABS CDO Issuance	Broker-dealer agency MBS desks	CMOs (res securitizations)
Step (6)	ABS Intermediation	GSE retained portfolios	Agency debt and discount notes
Step (7)	Wholesale Funding	2(a)-7 MMMFs, enhanced cash funds, securities lenders	\$1 NAV shares (GSE "deposits")

\*Funding types highlighted in red denote securitized funding techniques. Securitization techniques are *not* synonymous with secured funding.

Source: Shadow Banking (Pozsar, Adrian, Ashcraft, Boesky (2010))

Like banks, the GSEs fund their loan and securities portfolios with a maturity mismatch. Unlike banks, however, the GSEs are not funded using deposits, but through capital markets, where they issue short and long-term agency debt securities. These agency debt securities are bought by money market investors and real money investors such as fixed income mutual funds. The funding

functions performed by the GSEs on behalf of banks and the way in which GSEs are funded are the models for wholesale funding markets (see Exhibit 4 and Appendix 1).

The GSEs have embodied four intermediation techniques:

1. *Term loan warehousing* provided to banks by the FHLBs.
2. *Credit risk transfer* and transformation through credit insurance provided by Fannie Mae and Freddie Mac.
3. *Originate-to-distribute securitization* functions provided for banks by Fannie Mae and Freddie Mac.
4. *Maturity transformation* conducted through the GSE retained portfolios, which operate not unlike SIVs.<sup>6</sup>

Over the past thirty years or so, these four techniques have become widely adopted by banks and non-banks in their credit intermediation and funding practices. The adaptation of these techniques fundamentally changed the bank-based, originate-to-hold credit intermediation process and gave rise to the securitization-based, originate-to-distribute credit intermediation process.

Fannie Mae was privatized in 1968 in order to reduce government debt. Privatization removed Fannie from the government's balance sheet, yet it continued to have a close relationship with it and carry out certain policy mandates. Arguably, it also enjoyed an implicit government guarantee. This was similar to the off-balance sheet private shadow banks that were backstopped through liquidity guarantees by their sponsoring banks.

---

<sup>6</sup> Not unlike SIVs, all GSE debt and guarantees are off balance sheet to the federal government. No provisions are made for capital needs and balance sheet risks, and the GSEs are excluded from the federal budget. Their off-balance sheet nature is the same as those of bank sponsored SIVs and securities arbitrage conduits that had to be rescued by their sponsor banks. The GSE's are off-balance sheet shadow banks of the federal government.

The government-sponsored shadow banking sub-system is not involved in loan origination, only loan processing and funding.<sup>7</sup> These entities qualify as shadow banks to the extent that they are involved in the traditional bank activities of credit, maturity, or liquidity transformation, but without actually being chartered as banks and without having a meaningful access to a lender of last resort and an *explicit* insurance of their liabilities by the federal government.<sup>8</sup>

#### **4.2. The “Internal” Shadow Banking Sub-System**

The development of the GSEs’ activities described above has been mirrored by the evolution of a full-fledged shadow banking system over the past 30 years. The shadow banking system emerged from the transformation of the largest banks from low return on-equity (RoE) utilities that originate loans and hold and fund them until maturity with deposits, to high RoE entities that originate loans in order to warehouse and later securitize and distribute them, or retain securitized loans through off-balance sheet asset management vehicles. In conjunction with this transformation, the nature of banking has changed from a credit-risk intensive, deposit-funded, spread-based process, to a less credit-risk intensive, but more market-risk intensive, wholesale funded, fee-based process.

The vertical and horizontal slicing of credit intermediation is conducted through the application of a range of off-balance sheet securitization and asset management techniques (see Exhibit 5), which enable FHC-affiliated banks to conduct lending with less capital than if they had retained loans on their balance sheets. This process enhances the RoE of banks, or more precisely, the RoE of their holding companies.

---

<sup>7</sup> The GSEs are prohibited from loan origination by design. The GSEs create a secondary market for mortgages to facilitate the funding of mortgages.

<sup>8</sup> Note that Fannie and Freddie had some explicit backstops from the U.S. Treasury in the form of credit lines prior to their conservatorship in 2008. However, these liquidity backstops were very small compared to the size of their balance sheets.

## Exhibit 5: The Steps, Entities and Funding Techniques Involved in FHCs' Credit Intermediation Process

	Function	Shadow Banks	Shadow Banks' Funding*
Step (1)	Loan Origination	Commercial bank subsidiary	Deposits, CP, MTNs, bonds
Step (2)	Loan Warehousing	Single/multi-seller conduits	ABCP
Step (3)	ABS Issuance	SPVs, structured by broker-dealer subsidiary	ABS
Step (4)	ABS Warehousing	Hybrid, TRS/repo conduits, broker-dealers' trading books	ABCP, repo
Step (5)	ABS CDO Issuance	SPVs, structured by broker-dealer subsidiary	ABS CDOs, CDO-squareds
Step (6)	ABS Intermediation	SIVs, internal credit hedge funds (asset management)	ABCP, MTN, capital notes and repo
Step (7)	Wholesale Funding	2(a)-7 MMMFs, enhanced cash funds, securities lending subs.	\$1 NAV shares (shadow bank "deposits")

\*Funding types highlighted in red denote securitized funding techniques. Securitized funding techniques are *not* synonymous with secured funding.

Source: Shadow Banking (Pozsar, Adrian, Ashcraft, Boesky (2010))

Thus, whereas a traditional bank would conduct the origination, funding and risk management of loans on one balance sheet (its own), an FHC (1) originates loans in its bank subsidiary, (2) warehouses and accumulates loans in an off-balance sheet conduit that is managed by its broker-dealer subsidiary, is funded through wholesale funding markets, and is liquidity-enhanced by the bank, (3) securitizes loans via its broker-dealer subsidiary by transferring them from the conduit into a bankruptcy-remote SPV, and (4) funds the safest tranches of structured credit assets in an off-balance sheet ABS intermediary (a structured investment vehicle (SIV), for example) that is managed from the asset management subsidiary of the holding company, is funded through wholesale funding markets and is backstopped by the bank (see Appendix 2).

This process highlights three important aspects of the changed nature of lending in the U.S. financial system, especially for residential and commercial mortgage credit. First, the process of lending and the uninterrupted flow of credit to the real economy is no longer reliant on banks only, but on a process that spanned a network of banks, broker-dealers, asset managers and shadow banks—all under the umbrella of FHCs—funded through wholesale funding and capital markets globally. Second, a bank subsidiary's only direct involvement in an FHC's credit intermediation process is at the loan origination level. Its indirect involvements are broader, however, as it acts as a lender to the subsidiaries and off-balance sheet shadow banks involved in the warehousing and

processing of loans, and the distribution and funding of structured credit securities. Despite the fact that FHC's credit intermediation process depends on at least four entities other than the bank, only the bank subsidiary of an FHC has access to the Federal Reserve's discount window and benefits from deposit insurance. Third, lending has become capital efficient, fee-rich, high-RoE endeavor for originators, structurers and ABS investors. As the financial crisis of 2007-2009 shows, however, the capital efficiency of the process is highly dependent on liquid wholesale funding and debt capital markets globally. Paralysis in markets can thus turn banks' capital *efficiency* to capital *deficiency*, with systemic consequences.

This interpretation of the workings of FHCs is different from the one that emphasizes the benefits of FHCs as "financial supermarkets". According to that widely-held view, the diversification of the holding companies' revenues through broker-dealer and asset management activities makes the banking business more stable, as the holding companies' banks, if need be, could be supported by net income from other operations during times of credit losses. In our interpretation, the broker-dealer and asset management activities are not parallel, but serial and complementary activities to FHCs' banking activities.

### **4.3 The "External" Shadow Banking Sub-System**

Similar to the "internal" shadow banking sub-system, the "external" shadow banking sub-system is a global network of balance sheets, with the origination, warehousing and securitization of loans conducted mainly from the U.S., and the funding and maturity transformation of structured credit assets conducted from the U.S., but also from Europe and offshore financial centers. However, unlike the "internal" sub-system, the "external" sub-system is less of a product of regulatory arbitrage, and more a product of vertical integration and gains from specialization. The "external" shadow banking sub-system is defined by (1) the credit intermediation process of diversified broker-

dealers; (2) the credit intermediation process of independent, non-bank specialist intermediaries; and (3) the credit puts provided by private credit risk repositories.

### 4.3.1 The Credit Intermediation Process of Diversified Broker-Dealers

We refer to the standalone investment banks as they existed prior to 2008 as diversified broker-dealers (DBD). The DBDs vertically integrate their securitization businesses (from origination to funding), lending platforms, and asset management units. The credit intermediation process of DBDs is similar to those of FHCs (see Exhibit 6):

**Exhibit 6: The Steps, Entities and Funding Techniques Involved in DBDs' Credit Intermediation Process**

	Function	Shadow Banks	Shadow Banks' Funding*
Step (1)	Loan Origination	Finance company subsidiary	CP, MTNs, bonds
Step (2)	Loan Warehousing	Independent multi-seller conduits	ABCP
Step (3)	ABS Issuance	SPVs, structured by broker-dealer subsidiary	ABS
Step (4)	ABS Warehousing	Hybrid, TRS/repo conduits, broker-dealers' trading books	ABCP, repo
Step (5)	ABS CDO Issuance	SPVs, structured by broker-dealer subsidiary	ABS CDOs, CDO-squareds
Step (6)	ABS Intermediation	Internal credit hedge funds, proprietary trading desks	Repo
Step (7)	Wholesale Funding	2(a)-7 MMMFs, enhanced cash funds, securities lending subs.	\$1 NAV shares (shadow bank "deposits")

\*Funding types highlighted in red denote securitized funding techniques. Securitized funding techniques are *not* synonymous with secured funding.

Source: Shadow Banking (Pozsar, Adrian, Ashcraft, Boesky (2010))

The diversified broker dealers are distinguished by the fact that they do not own commercial bank subsidiaries. Most of the major standalone investment banks did, however, own industrial loan company (ILC) subsidiaries. Since running one's own loan warehouses (single- or multi-seller loan conduits) requires large bank subsidiaries to fund the contingent liquidity backstops that enhance the ABCP issued by the conduits, broker-dealers typically outsourced these warehousing functions to FHCs with large deposit bases, or to independent multi-seller, hybrid or TRS conduits. At the end of their intermediation chains, DBDs don't operate securities arbitrage conduits or SIVs. Instead, internal credit hedge funds, trading books and repo conduits act as funding vehicles. Partly due to this reason, the DBDs' intermediation process tends to be more reliant on repo funding than that of FHCs', which relied on CP, ABCP, MTNs and repos. The types of credit intermediated by diversified broker-dealers is similar to FHCs, with the exception that they do not originate credit

card loans (which are the near-exclusive domain of FHCs) and are less prominent lenders of conforming mortgages, FFELP student loans and SBA loans.

Prior to the creation of the Primary Dealer Credit Facility, the only DBD subsidiaries that were backstopped by the Federal Reserve or the FDIC were the ILC and FSB subsidiaries. The numerous other subsidiaries that are involved in the origination, processing and movement of loans and structured credits as they pass through DBDs' credit intermediation process do not have direct access to these public enhancements.

It should be noted that the credit intermediation processes described here are the simplest and shortest forms of the intermediation chains that run through FHCs and DBDs. In practice, these processes are often elongated by additional steps involved in the warehousing, processing and distribution of unsold ABS into ABS CDOs (also see Appendix 3).

#### **4.3.2 The Independent Specialists-Based Credit Intermediation Process**

The credit intermediation process that runs through a network of independent, specialist non-bank financial intermediaries perform the very same credit intermediation functions as those performed by traditional banks or the credit intermediation processes of FHCs and DBDs. The independent specialists-based intermediation process includes the following types of entities: stand-alone and captive finance companies on the loan origination side<sup>9</sup>; independent multi-seller conduits on the

---

<sup>9</sup> Captive finance companies are finance companies that are owned by non-financial corporations. Captive finance companies are typically affiliated with manufacturing companies, but might also be affiliated with homebuilders as well, for example. Captive finance companies are used to provide vendor financing services for their manufacturing parents' wares. Some captive finance companies are unique in that they do not finance solely the sale of their parent's wares, but instead a wide-range of loan types, many of which are hard, or impossible for banks to be active in. Captive finance companies often benefit from the highly-rated nature of their parents, which gives them access to unsecured funding at competitive terms. Stand alone finance companies, as the name suggests stand on their own and are not subsidiaries of any other corporate entity.

loan warehousing side; and limited purpose finance companies (LPFCs), independent SIVs and credit hedge funds on the ABS intermediation side (see Exhibit 7).

**Exhibit 7: The Steps, Entities and Funding Techniques Involved in the Independent Specialists-Based Credit Intermediation Process**

	Function	Shadow Banks	Shadow Banks' Funding*
Step (1)	Loan Origination	Standalone and captive finance companies	CP, MTNs and bonds
Step (2)	Loan Warehousing	FHC-sponsored and independent multi-seller conduits	ABCP
Step (3)	ABS Issuance	SPVs, structured by broker-dealers	ABS
Step (4)	ABS Warehousing	-	ABCP, repo
Step (5)	ABS CDO Issuance	-	ABS CDOs, CDO-squareds
Step (6)	ABS Intermediation	LPFCs, independent SIVs, independent credit hedge funds	ABCP, MTN, capital notes and repo
Step (7)	Wholesale Funding	2(a)-7 MMMFs, enhanced cash funds, securities lenders.	\$1 NAV shares (shadow bank "deposits")

\*Funding types highlighted in red denote securitized funding techniques. Securitized funding techniques are *not* synonymous with secured funding.

Source: Shadow Banking (Pozsar, Adrian, Ashcraft, Boesky (2010))

There are three key differences between the independent specialists-based credit intermediation process and those of FHCs and DBDs. First, and foremost, on the origination side, these three processes intermediate different types of credit. The FHC and DBD-based processes originate some combination of both conforming and non-conforming mortgages, as well as commercial mortgages, leveraged loans and credit card loans. In contrast, the independent specialists-based process tends to specialize in the origination of auto and equipment loans and leases, middle-market loans, franchise loans and more esoteric loans in which traditional banks and FHCs becomes less and less active over time. The obvious exceptions to this are standalone non-conforming mortgage finance companies, which are largely extinct since the crisis.<sup>10</sup> The independent specialists-based credit intermediation process is based on an “originate-to-fund” (again, with the exception of the now extinct standalone mortgage finance companies) as opposed to the mostly “originate-to-distribute” model of the government-sponsored shadow banking sub-system and FHCs’ and DBDs’ credit intermediation process. While the GSE, FHC and DBD-based credit intermediation

<sup>10</sup> It is fair to say that the independent specialists-based credit intermediation process became collateral damage in the collapse of standalone subprime mortgage originators and subprime securitizations.



processes are heavily dependent on liquid capital markets for their ability to fund, securitize and distribute their loans, independent specialists' seamless functioning is also exposed to DBDs' and FHCs' abilities to perform their functions as gatekeepers to capital markets and lenders of last resort, respectively. This in turn represents an extra layer of fragility in the structure of the independent specialists-based credit intermediation process, as failure by FHCs and DBDs to perform these functions in times of systemic stress ran the risk of paralyzing and disabling the independent specialists-based intermediation process (see Rajan (2005)). Indeed, this fragility became apparent during the financial crisis of 2007-2009 as the independent specialists-based process broke down, and with it the flow of corresponding types of credit to the real economy. Appendix 4 shows the relative extent to which specialist loan originators (captive and independent finance companies) relied on FHCs and DBDs as their ABS underwriters and gatekeepers to capital markets.

#### **4.3.3 Private Credit Risk Repositories**

While the credit intermediation process of independent specialists is highly reliant on FHCs and DBDs, FHCs and DBDs in turn rely heavily on private credit risk repositories to perform originate-to-distribute securitizations (see Appendix 5). Private risk repositories specialize in providing credit transformation services in the shadow banking system, and include mortgage insurers, monoline insurers, certain subsidiaries of large, diversified insurance companies, credit hedge funds and credit derivative product companies. These entities, as investors in the junior equity and mezzanine tranches of loan pools, all provide risk capital to the shadow banking system, thereby supporting credit extension to the real economy.

Different credit risk repositories correspond to specific stages of the shadow credit intermediation process. As such, mortgage insurers specialize in insuring, or wrapping whole mortgage loans;

monoline insurers specialize in wrapping ABS tranches (or the loans backing a specific ABS tranche); and large, diversified insurance companies, credit hedge funds and credit derivative product companies specialize in taking on the risks of ABS CDO tranches through CDS.<sup>11</sup> There are also overlaps, with some monolines wrapping both ABS and ABS CDOs, for example.

Effectively, the various forms of credit put options provided by private risk repositories absorb tail risk from loan pools, turning the enhanced securities into credit-risk free securities (at least from investors' perception prior to the crisis). This in turn means that any liability that issued against these assets is perceived to be credit-risk free as well, as if it is FDIC-insured.

The perceived, credit-risk free nature of traditional banks' and shadow banks' liabilities stem from two very different sources. In the case of traditional banks' insured liabilities (deposits), the credit quality is driven by the counterparty—the U.S. taxpayer. As a result, insured depositors invest less effort into examining a bank's creditworthiness before depositing money than if they are uninsured. In the case of shadow banks' liabilities (repo or ABCP, for example), perceived credit quality is driven by the "credit-risk free" nature of collateral that backs shadow bank liabilities, as it is often enhanced by private credit risk repositories.

The credit puts provided by private credit risk repositories are alternatives to the credit transformation performed by (1) the credit risk-based calibration of advance rates and attachment points on loan pools backing top-rated ABCP and ABS tranches, respectively; (2) the credit risk-based calibration of haircuts on collateral backing repo transactions; (3) the capital notes supporting LPFCs' and SIVs portfolios of assets, and (4) the pooling and re-packaging of non-AAA rated term

---

<sup>11</sup> CDS were also used for hedging warehouse and counterparty exposures. For example a broker-dealer with a large exposure to subprime MBS that it warehoused for an ABS CDO deal in the making could purchase CDS protection on its MBS warehouse. In turn, the broker-dealer could also purchase protection (a counterparty hedge) from a credit hedge fund or CDPC on the counterparty providing the CDS protection on subprime MBS.

ABS into ABS CDOs. The credit puts of private credit risk repositories are also similar in function to the wraps provided by Fannie Mae and Freddie Mac on conforming mortgage pools.<sup>12</sup> Just as these government-sponsored, public credit risk repositories “borrowed” the AAA-rating of the federal government to pools of mortgage loans (turning them into credit risk-free rate products), the private credit risk repositories were effectively “borrowing” the AAA-rating of their parent.

#### **4.4 The “Parallel” Banking System**

Many “internal” and “external” shadow banks exist in a form that is only possible due to special circumstances in the run up to the financial crisis—some economic in nature and some due to regulatory and risk management failures. However, there are also many examples of shadow banks that exist due to gains from specialization and comparative advantage over traditional banks. Such shadow banks were not driven by regulatory arbitrage, but by gains from specialization as a “parallel” banking system. Most (but not all) of these entities can be found in the “external” shadow banking sub-system.

These entities include non-bank finance companies, which can be more efficient than traditional banks through specialization and economies of scale in the origination, servicing, structuring, trading and funding of loans to both bankable and non-bankable credits.<sup>13</sup> For example, finance companies have traditionally served subprime credit card or auto loan customers, or low-rated corporate credits like the commercial airlines, which are not served by banks. Furthermore, some ABS intermediaries could fund highly-rated structured credit assets at lower cost and lower levels of leverage than banks with high RoE targets.

---

<sup>12</sup> Credit wraps come in different forms and guarantee the timely payment of principal and interest on an underlying debt obligation.

<sup>13</sup> Carey, Post, and Sharpe (1998) document the specialization of finance companies among riskier borrowers.

Over the last thirty years, market forces have pushed a number of activities outside of banks and into the parallel banking system. It remains an open question whether or not the “parallel” banking system will ever be stable through credit cycles in the absence of official credit and liquidity puts. If the answer is no, then there are questions about whether or not such puts and the associated prudential controls should be extended to parallel banks, or, alternatively, whether or not parallel banking activity should be severely restricted. For a spectrum of shadow banking activities by type, see Appendix 6.

#### **4.5 BACKSTOPPING THE SHADOW BANKING SYSTEM**

The Federal Reserve’s 13(3) emergency lending facilities that followed in the wake of Lehman’s bankruptcy amount to a backstop of all the functional steps involved in the shadow credit intermediation process. The facilities introduced during the crisis were an explicit recognition of the need to channel emergency funds into “internal”, “external” and government-sponsored shadow banking sub-systems (for a pre- and post-crisis backstop of shadow banks see Appendixes 7 and 8).

As such, the Commercial Paper Funding Facility (CPFF) was a backstop of the CP and ABCP issuance of loan originators and loan warehouses, respectively (steps 1 and 2 of the shadow credit intermediation process); the Term Asset-Backed Loan Facility (TALF) is a backstop of ABS issuance (step 3); Maiden Lane LLC was a backstop of Bear Stearns’ ABS warehouse, while the Term Securities Lending Facility (TSLF) was a means to improve the average quality of broker-dealers securities warehouses through swapping ABS for Treasuries (step 4); Maiden Lane III LLC was a backstop of AIG-Financial Products’ credit puts on ABS CDOs (step 5); and the Term Auction Facility (TAF) and the FX swaps with foreign central banks were meant to facilitate the

“onboarding” and on-balance sheet, dollar funding of the ABS portfolios of formerly off-balance sheet ABS intermediaries—mainly SIVs and securities arbitrage conduits (step 6).<sup>1415</sup>

Finally, the Primary Dealer Credit Facility (PDCF) was a backstop of the tri-party repo system through which MMMFs and other funds fund broker-dealers in wholesale funding markets overnight, and the AMLF and the Money Market Investor Funding Facility (MMIFF<sup>1</sup>) served as liquidity backstops of regulated and unregulated money market intermediaries, respectively (step 7).

Similarly, the FDIC’s Temporary Liquidity Guarantee Program that covered (1) various bank and non-bank financial institutions’ senior unsecured debt, (2) corporations’ non-interest bearing deposit transaction accounts, regardless of dollar amount, and (3) the U.S. Department of Treasury’s temporary guarantee program of retail and institutional money market mutual funds were also backstops to the funding of the shadow banking system, and are all modern-day equivalents of deposit insurance. Upon the full rollout of the liquidity facilities, large-scale asset purchases and guarantee schemes, the shadow banking system was fully embraced by official credit and liquidity puts, and became fully backstopped, just like the traditional banking system. As a result, the run on it was fully checked.

---

<sup>14</sup> The CPFF is documented in detail by Adrian, Marchioni, Kimbrough (2009); TSLF is described by Fleming, Hrungr, Keane (2009); TALF is described by Campbell, Covitz, Nelson, Pence (2011) and Ashcraft, Malz, Pozsar (2010); the PDCF is in Adrian, Burke, and McAndrews (2009); TAF is in Armentier, Krieger, McAndrews (2008).

<sup>15</sup> The TAF facility was only available to bank or FHC-affiliated ABS intermediaries. Standalone ABS intermediaries (LPFCs and independently managed SIVs and securities arbitrage conduits) and the ABS intermediaries of pension funds, insurance companies and monoline insurers did not benefit from “intermediated” access to the discount window.

## 5. CONCLUSIONS

We document the specialized financial institutions of the shadow banking system, and argue that these specialized financial intermediaries played a quantitatively important role in the run-up to the financial crisis. Shadow credit intermediation includes three broad types of activities, differentiated by their strength of official enhancement: implicitly-enhanced, indirectly-enhanced, and unenhanced. The shadow banking system has three sub-systems which intermediate different types of credit, in fundamentally different ways. The government-sponsored shadow banking sub-system refers to credit intermediation activities funded through the sale of Agency debt and MBS, which mainly includes conforming residential and commercial mortgages. The “internal” shadow banking sub-system refers to the credit intermediation process of a global network of banks, finance companies, broker-dealers and asset managers and their on- and off-balance sheet activities—all under the umbrella of financial holding companies. Finally, the “external” shadow banking sub-system refers to the credit intermediation process of diversified broker-dealers (DBDs), and a global network of independent, non-bank financial specialists that include captive and standalone finance companies, limited purpose finance companies and asset managers. While much of the current and future reform effort is focused remediating the excesses of the recent credit bubble, we note that increased capital and liquidity standards for depository institutions and insurance companies are likely to increase the returns to shadow banking activity. For example, as pointed out in Pozsar (2011), the reform effort has done little to address tendency for large institutional cash pools to form outside the banking system. Thus, we expect shadow banking to be a significant part of the financial system, though almost certainly in a different form, for the foreseeable future.

## REFERENCES

Adrian, Tobias, Chris Burke, and Jamie McAndrews (2009): “The Federal Reserve’s Primary Dealer Credit Facility,” *Federal Reserve Bank New York Current Issues Economics and Finance* 15(4).

Adrian, Tobias, Dina Marchioni and Karin Kimbrough (2009): “The Federal Reserve’s Commercial Paper Funding Facility,” *Federal Reserve Bank of New York Economic Policy Review*, forthcoming.

Adrian, Tobias and Hyun Song Shin (2009): “The Shadow Banking System: Implications for Financial Regulation,” *Banque de France Financial Stability Review* 13, pp. 1-10.

Adrian, Tobias and Hyun Song Shin (2010a): “Liquidity and Leverage,” *Journal of Financial Intermediation* 19(3) pp. 418—437.

Adrian, Tobias and Hyun Song Shin (2010b): “The Changing Nature of Financial Intermediation and the Financial Crisis of 2007–2009,” *Annual Review of Economics*, forthcoming.

Aitken, James and Manmohan Singh (2009): “Deleveraging after Lehman—Evidence from Reduced Rehypothecation,” *IMF Working Paper* 09/42.

Armantier Olivier, Sandy Krieger and Jamie McAndrews (2008): “The Federal Reserve’s Term Auction Facility,” *Federal Reserve Bank of New York Current Issues in Economics and Finance* 14(5).

Ashcraft, Adam B. (2005): “Are Banks Really Special? New Evidence from the FDIC-Induced Failure of Healthy Banks,” *American Economic Review* 95(5).

Ashcraft, Adam B., and Til Schuermann (2007): “Understanding the Securitization of Subprime Mortgage Credit,” *Foundations and Trends in Finance* 2(3).

Ashcraft, Adam, Allan Malz, and Zoltan Pozsar (2010): “The Federal Reserve’s Term Asset-Backed Securities Loan Facility,” *Federal Reserve Bank of New York Economic Policy Review*, forthcoming.

Bernanke, Ben S. (1983): “Nonmonetary Effects of the Financial Crisis in the Propagation of the Great Depression,” *American Economic Review* 73(3).

Brunnermeier, Markus (2009): “De-ciphering the credit crisis of 2007,” *Journal Economic Perspectives* 23(1): pp. 77–100.

Campbell, Sean and Daniel Covitz, William Nelson and Karen Pence (2011): “Securitization markets and central banking: an evaluation of the term asset-backed securities loan facility,” *Journal of Monetary Economics* 58(5), pp. 518-531.

Carey, Mark, Mitch Post, Steven A. Sharpe (1998) “Does Corporate Lending by Banks and Finance Companies Differ? Evidence on Specialization in Private Debt Contracting,” *Journal of Finance* 53(3), p. 845–878.

Corrigan, Gerald (2000): “Are Banks Special?—A Revisitation” *The Region, Banking and Policy Issues Magazine*, March 2000, the Federal Reserve Bank of Minneapolis

- Covitz, Daniel, Nellie Liang, and Gustavo Suarez (2009): “The Evolution of a Financial Crisis: Panic in the Asset-Backed Commercial Paper Market,” *Board of Governors of the Federal Reserve System Finance and Economics Discussion Series* 2009-36.
- Coval, Joshua, Jakub Jurek, and Erik Stafford (2009): “The Economics of Structured Finance,” *Journal of Economic Perspectives* 23(1), pp. 3–25.
- Diamond, Douglas and Philip Dybvig (1983): “Bank runs, deposit insurance, and liquidity,” *Journal of Political Economy*, pp. 401—419.
- Eichner, Matthew, Donald Kohn and Michael Palumbo (2010): “Financial Statistics for the United States and the Crisis: What Did They Get Right, What Did They Miss, and How Should They Change?” *Finance and Economics Discussion Series* 2010-20.
- Fleming, Michael, Warren Hrungr, Frank Keane (2009): “The Term Securities Lending Facility: Origin, Design, and Effects,” *Federal Reserve Bank of New York Current Issues of Economics and Finance* 15(2).
- Geanakoplos, John (2010): “The Leverage Cycle,” in *NBER Macroeconomics Annual* 2009, ed. Daron Acemoglu, Kenneth Rogoff, Michael Woodford. Chicago: Univ. Chicago Press.
- Gertler, Mark and John Boyd (1993): “U.S. Commercial Banking: Trends, Cycles and Policy,” *NBER Macroeconomics Annual*, Olivier Blanchard and Stanley Fischer, editors, 1993.
- Gorton, Gary (2009): “Slapped in the Face by the Invisible Hand: Banking and the Panic of 2007” *Federal Reserve Bank of Atlanta Jeekyll Island Conference Proceedings*.
- Martin, Antoine and David Skeie and Elu von Thadden (2011): “Repo runs,” FRB of New York Staff Report No. 444.
- Merton, Robert C. (1977): “An Analytical Derivation of the Cost of Deposit Insurance and Loan Guarantees,” *Journal of Banking and Finance* 1, pp. 3-11.
- Merton, Robert C. and Zvi Bodie (1993): “Deposit Insurance Reform: A Functional Approach,” *Carnegie-Rochester Conference Series on Public Policy*, 38 (1993) 1-34.
- McCulley, Paul (2007): “Teton Reflections,” *PIMCO Global Central Bank Focus*
- Morris, Stephen and Hyun Song Shin (2004): “Coordination risk and the price of debt,” *European Economic Review* 48(1), pp. 133—154.
- Pozsar, Zoltan (2008): “The Rise and Fall of the Shadow Banking System,” Moody's Economy.com.
- Pozsar, Zoltan (2010): “Institutional Cash Pools and the Triffin Dilemma of the US Banking System,” IMF Working Paper No. 11/190.
- Wachter, Susan, Andrey Pavlov and Zoltan Pozsar (2008): “Subprime Lending and Real Estate Markets,” in *Mortgage and Real Estate Finance*, edited by Stefania Perrucci, Risk Books.



## Appendix 1: The Government-Sponsored Shadow Banking System

The shadow credit intermediation process, and the shadow banking system were to a great extent inspired by the government sponsored enterprises, namely the FHLB system, Fannie Mae and Freddie Mac. The GSEs are creations of lawmakers and are **off-balance sheet "shadow banks"** of the U.S. Federal Government. The GSEs that make up the government-sponsored shadow banking system perform similar functions to term multi-seller conduits, credit risk repositories, and LPFCs and SIVs in the "private" shadow banking system. Thus, similar to multi-seller conduits, the FHLB system provides term loan warehousing for conforming mortgages (and other loans) to member commercial banks; similar to monoline insurers, Fannie Mae and Freddie Mac provide guarantees on the loans that back Agency MBS, turning them into credit risk-free rate products; and similar to SIVs or LPFCs, the GSE retained portfolios conduct maturity transformation on pools of mortgages and private-label term ABS. These are either (1) funded with the FHLBs through maturity, or (2) are sold in the "TBA" market in order to be packaged into Agency MBS. As the loans pass through the TBA process, Fannie or Freddie provide guarantees on the loan pools, assuming the credit risk out of them. Some of the Agency MBS might end up being packaged into collateralized mortgage obligations (CMOs) which time-tranche the underlying cash-flows of mortgage pools. The short-dated tranches of CMOs are sold to 2(a)-7 MMMFs and other funds. Similarly, the GSE retained portfolios are funded through a mix of short-dated Agency discount notes (the GSE equivalent of private CP and ABCP) and Agency debt (the GSE equivalents of private MTNs and bonds) that are also sold to MMMFs and real money accounts, respectively.

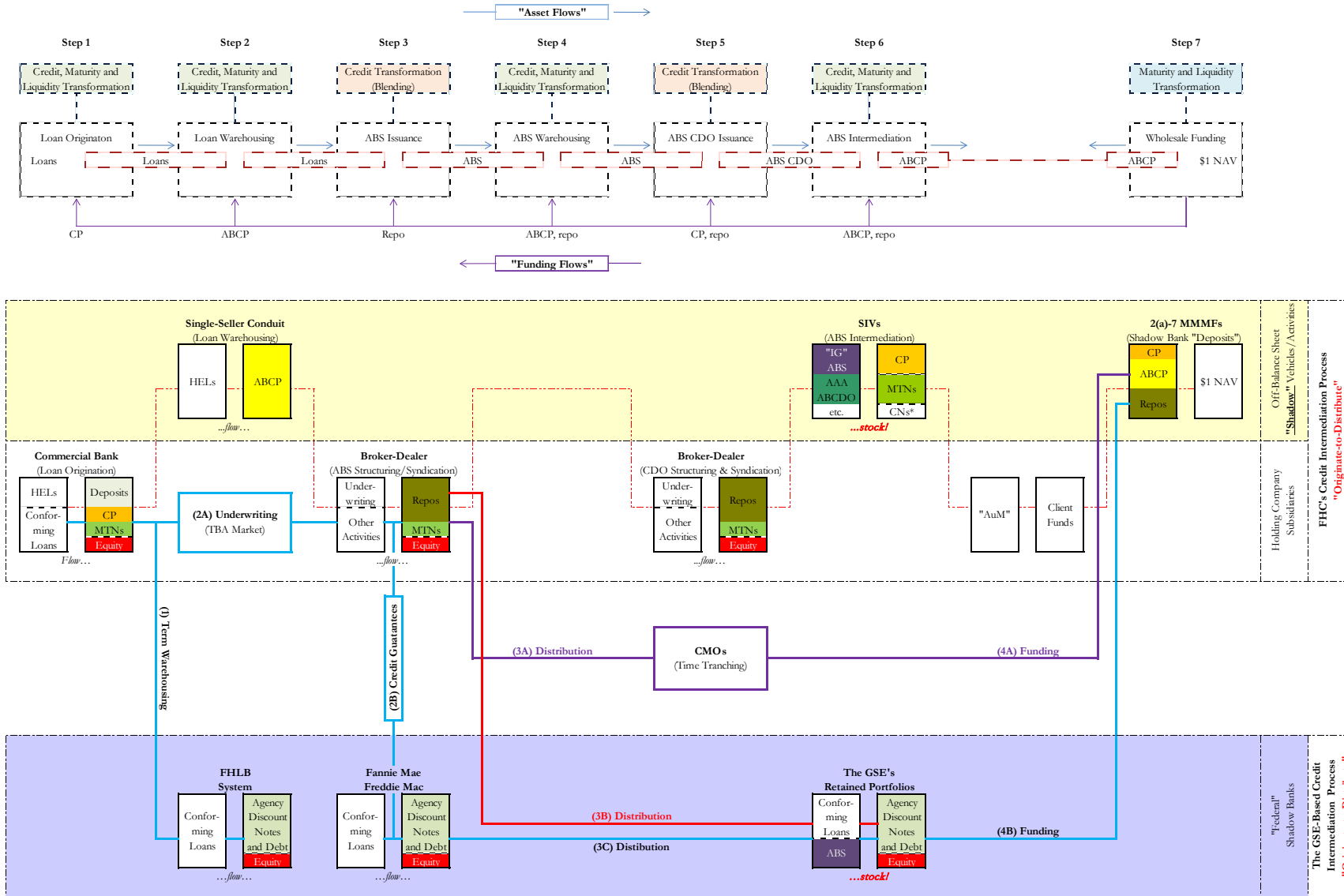

Source: Shadow Banking (Pozsar, Adrian, Ashcraft, Boesky (2010))

## Appendix 2: The Credit Intermediation Process of Bank Holding Companies

The credit intermediation process of Financial Holding Companies flows through a chain of subsidiaries and off-balance sheet vehicles (shadow banks), and is funded in capital markets. This intermediation chain enhances the efficiency of bank equity for various reasons. If markets freeze and the FHC's subsidiaries have to "onboard" their normally off-balance sheet assets and activities, capital efficiency can quickly become capital deficiency, with systemic consequences. The process described here is an **originate-to-distribute** model of non-conforming mortgages, where the originating banks and the broker-dealers that slice and dice mortgages into ABS and ABS CDOs do not retain any first loss pieces along the intermediation chain.

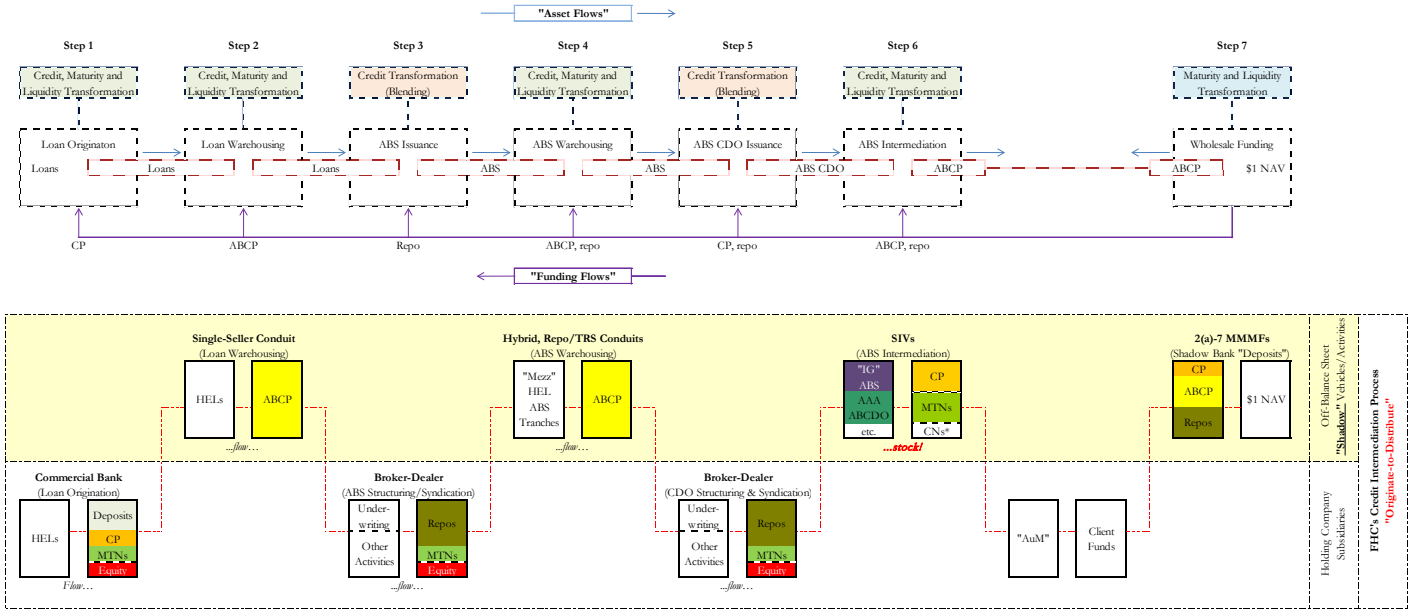

Source: Shadow Banking (Pozsar, Adrian, Ashcraft, Boesky (2010))

## Appendix 3: The Credit Intermediation Process of Diversified Broker-Dealers

The credit intermediation process of Diversified Broker-Dealers (DBD) is similar to that of FHC's (see Figure XX), with only a few differences. First, DBDs originate loans out of finance company subsidiaries, not commercial bank subsidiaries. Second, DBDs warehouse loans not in conduits, but in industrial loan company subsidiaries; alternatively, DBDs can outsource loan warehousing to a multi-seller conduit run by an FHC. Third, ABS warehousing is also not conducted from conduits, but from trading books. Finally, ABS intermediation is not conducted through SIVs, but through internal credit hedge funds. On a funding level, DBD's intermediation process is more reliant on brokered deposits and repo, compared to the FHC process, which is more reliant on branch deposits, CP and ABCP.

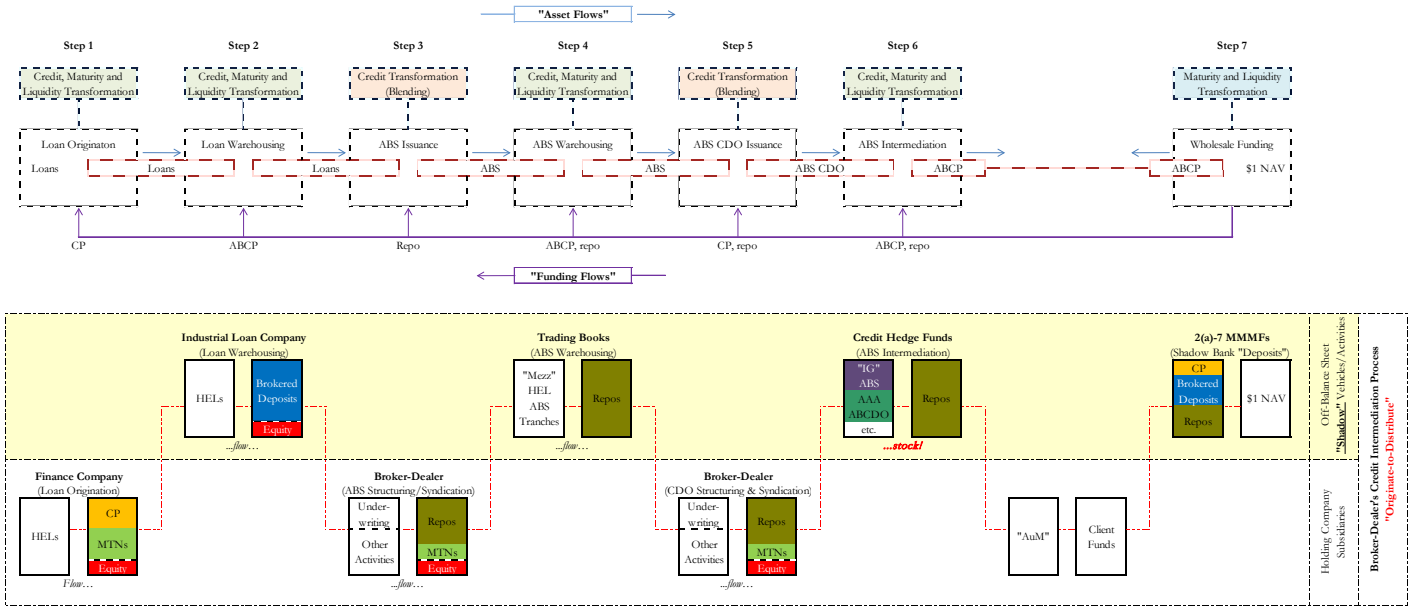

Source: Shadow Banking (Pozsar, Adrian, Ashcraft, Boesky (2010))

#### Appendix 4: The Independent Specialists-Based Credit Intermediation Process – Specialists Reliance on FHCs and DBDs as Gatekeepers to Capital Markets

The independent specialists-based credit intermediation process consists of entities like independent and captive finance companies on the loan origination side; limited purpose finance companies (LPFCs) and standalone SIVs and credit hedge funds on the ABS intermediation side; and LGIPS and non-bank affiliated MMMFs on the funding side. The independent specialists-based credit intermediation process is highly dependent on FHCs and DBDs as gatekeepers to capital markets and as underwriters of their securitization-based credit intermediation process. For example, starting from the bottom left balance sheet ("Captive or Standalone Finance Companies") and going to the right along the red line, finance companies rely on (1) FHC-affiliated multi-seller conduits for loan warehousing, (2) broker-dealers for the structuring and syndication of the ABS that funds their retained loans, which by definition are **originate-to-fund** securitizations (in contrast to FHCs' and DBDs' originate-to-distribute securitizations); (3) broker-dealers for the distribution of ABS to LPFCs (path 3A) and alternatively to SIVs (path 3B) that are affiliated with the FHC that owns the broker-dealer. Additionally, along the green line that begins from the balance sheet labeled "LPFCs", LPFCs rely on broker-dealers to underwrite their CP (as well as MTNs and capital notes) and (2) distribute them to FHC/DBD-affiliated MMMFs and LGIPS (paths 2A and 2B, respectively), as well as real money accounts, which are not depicted. Also note that the below figure do not depict the entire FHC process from Figure XX, only those parts of it that are relevant to the credit intermediation process of independent specialists.

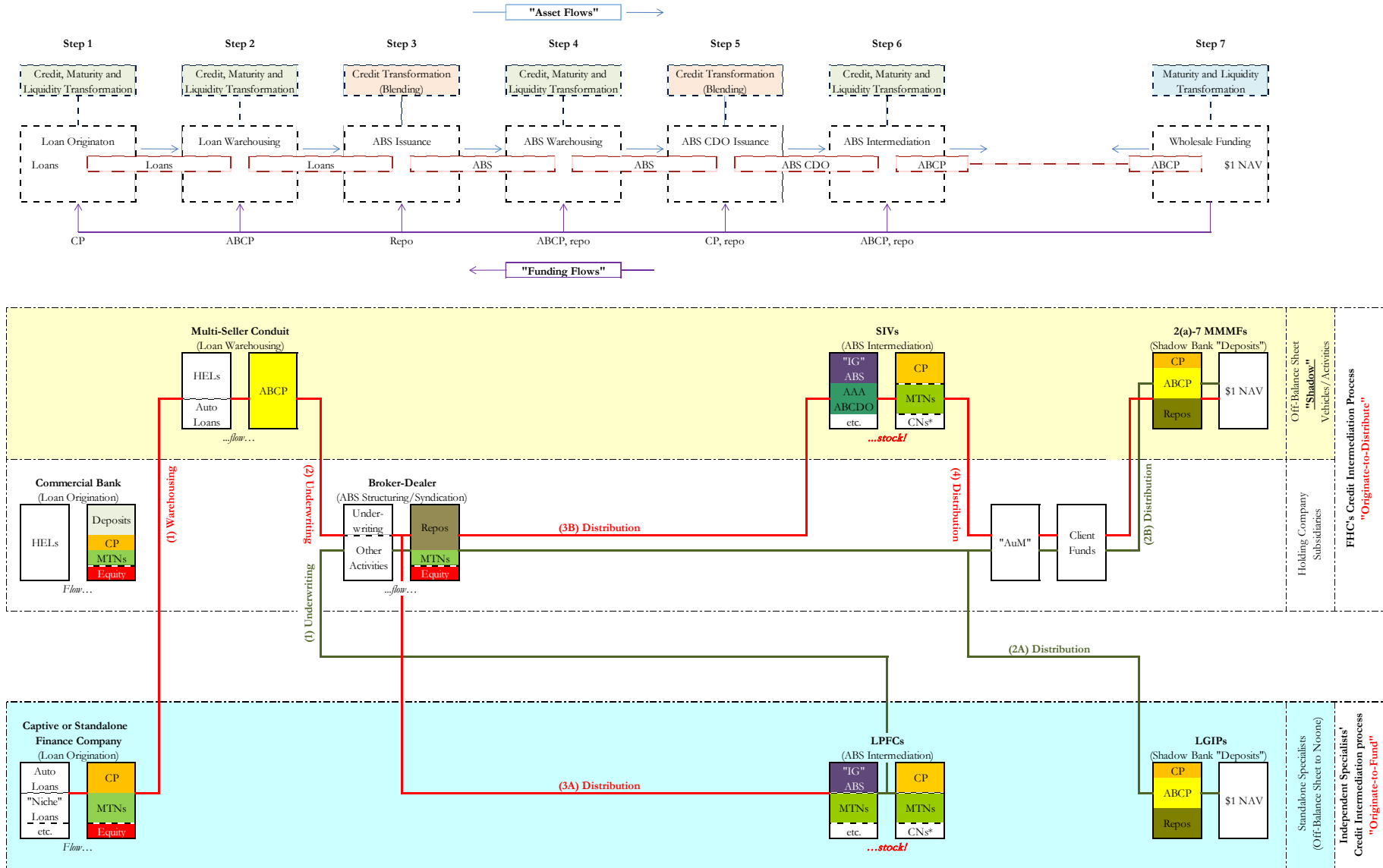

Source: Shadow Banking (Pozsar, Adrian, Ashcraft, Boesky (2010))

## Appendix 5: The Independent Specialists-Based Credit Intermediation Process – FHCs' and DBDs' Reliance on Independent Specialists

The "internal" and "external" shadow banking sub-systems are symbiotic. Not only is the independent specialists-based credit intermediation process dependent on FHCs and DBDs as warehouse providers and gatekeepers to capital markets, but FHCs and DBDs also relied on members of the "external" shadow banking system for funding and other functions. As such, independent specialists like LPFCs and securities lenders, for example, are instrumental in funding commercial banks and broker-dealers by buying their term debt. Furthermore, entities called private risk repositories were turning loan pools into AAA-rated, informationally insensitive securities, which in turn served as collateral in secured funding transactions. An example of such a transaction would be a repo collateralized by monoline-wrapped AAA-rated subprime RMBS, where a broker-dealer pledges the RMBS collateral for an overnight cash loan from a 2(a)-7 MMMF. Credit risk repositories were present in both **originate-to-distribute** and **originate-to-fund** securitization chains, and each type of risk repository corresponded to specific stages of the shadow credit intermediation process. As such, mortgage insurers wrapped unsecured mortgage pools, monoline insurers wrapped ABS (on either the loan pool or the tranche side of deals) while entities like AIG-Financial Products (as well as credit hedge funds, and German Landesbanks' SIVs and conduits (famously IKB's Rhineland by investing in the infamous ABACUS 2007-AC1 deal)) were selling CDS on ABS CDOs. Credit risk repositories made the originate-to-distribute process seem riskless and essentially played the role of private-sector versions of the FDIC in the system.

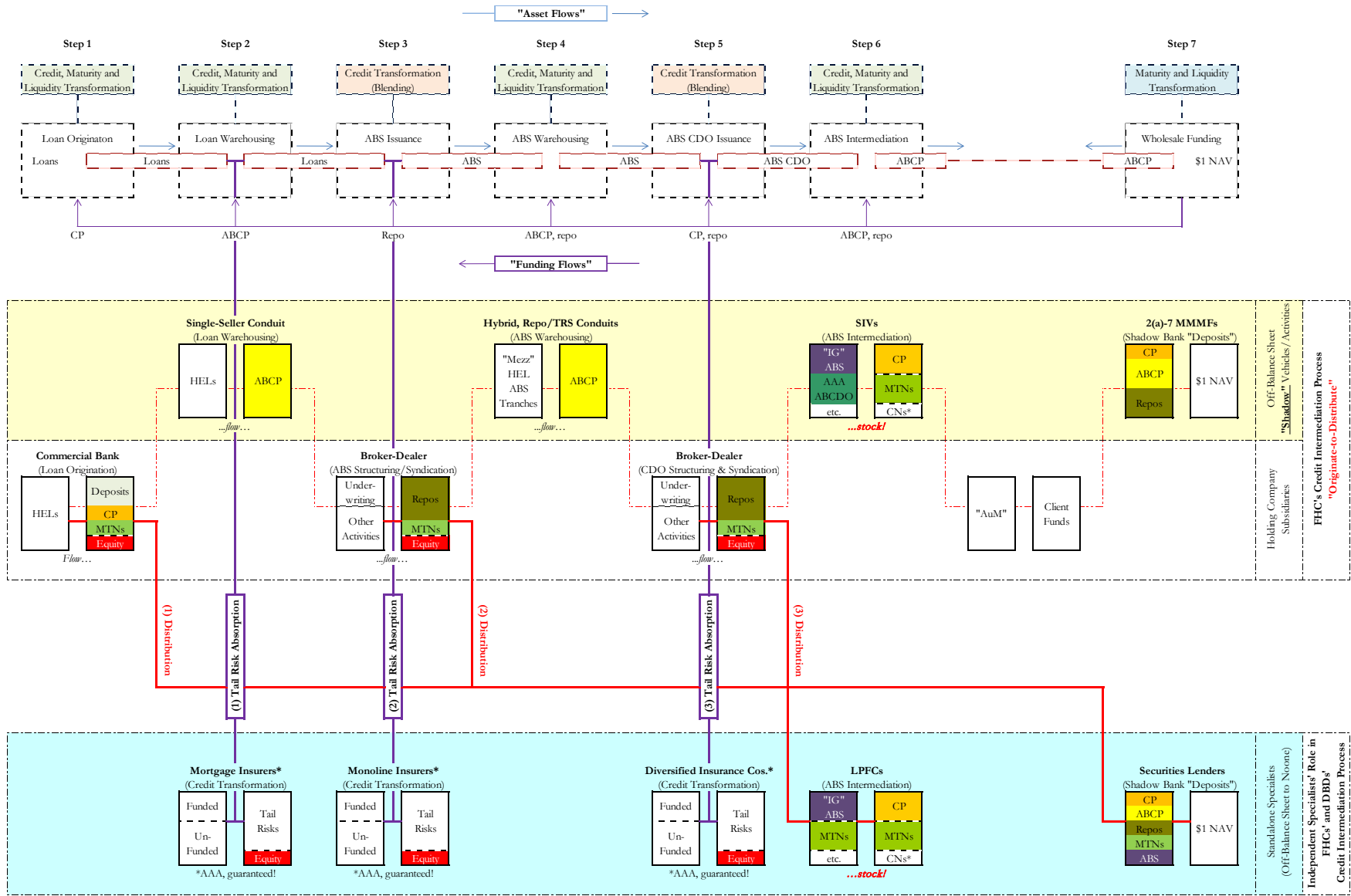

Source: Shadow Banking (Pozsar, Adrian, Ashcraft, Boesky (2010))

## Appendix 6: The Spectrum of Shadow Banks within a Spectrum of Shadow Credit Intermediation

Shadow banks are best thought along a spectrum. Each of the seven steps involved in the shadow credit intermediation process were performed by many different types of shadow banks, with varying asset mixes, funding strategies, amounts of capital and degrees of leverage. The list of balance sheets below are an illustrative example of this. Thus, the shadow credit intermediation process was supported by various forms of equity of various degrees of strength (each denoted with a red cell): as such, equity came in the form of common equity, overcollateralization (O/C), haircuts, equity tranches and capital notes. Wholesale funding providers (money market mutual funds, securities lenders) were the only actors involved in the shadow credit intermediation process without any form of capital supporting their activities. Having numerous types of shadow banks under each functional step of the shadow credit intermediation process means that each functional step can be performed many different ways. Depending on the asset mix and funding strategy employed, different shadow banks performing the same functions in the system conducted different amounts of credit, maturity and liquidity transformation. Shadow banks are listed vertically, top-down, in increasing order of riskiness.

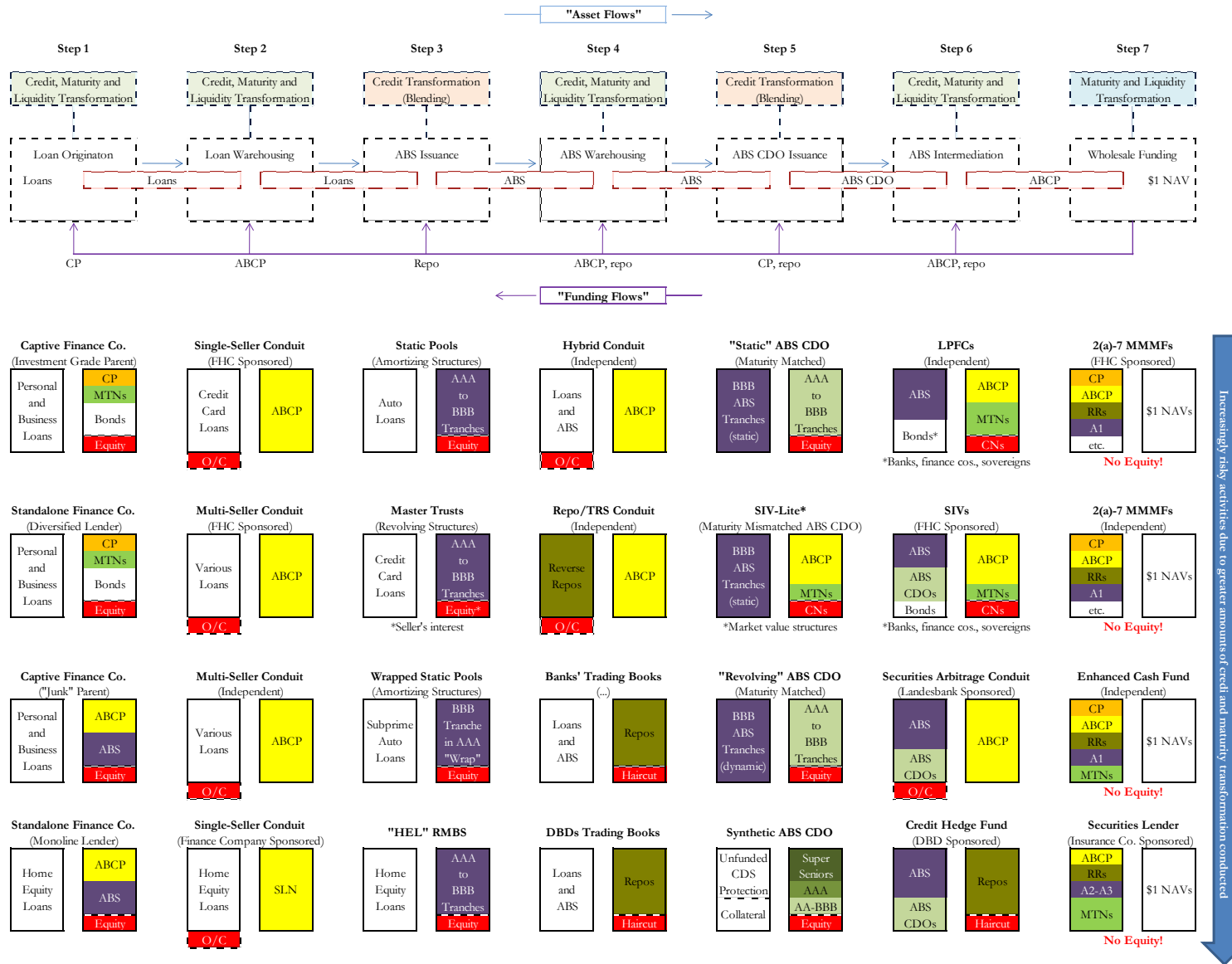

Source: Shadow Banking (Pozsar, Adrian, Ashcraft, Boesky (2010))

## Appendix 7: The Pre-Crisis Backstop of the Shadow Credit Intermediation Process – The Case of FHCs

Prior to the financial crisis, the credit intermediation process of the shadow banking system was privately enhanced. In this figure, we examine the enhancements to a typical FHC's credit intermediation process. Of the seven steps involved in the shadow credit intermediation process, only the first step (loan origination) is officially enhanced as it is conducted from a commercial bank. The commercial bank's activities are backstopped by credit and liquidity puts provided by the FDIC and the Federal Reserve through deposit insurance and discount window lending, respectively. The remaining six steps in an FHC's credit intermediation were privately enhanced, however. Consortiums of commercial banks were providing liquidity puts through contractual credit lines to conduits and SIVs (loan and ABS warehouses, and ABS intermediaries, respectively) and the tri-party clearing banks (JP Morgan Chase and BoNY) were providing intra-day credit to broker-dealers and daytime unwinds of overnight repos to MMMFs that fund them. Private credit risk repositories were making risky assets safe by "wrapping" them with credit puts. The loans, ABS, and CDOs wrapped by mortgage insurers, monoline insurers and AIG-IP, respectively, circulated in the system as credit-risk free assets that were used for collateral for funding via ABCP and repo. When the quality of these credit puts came into question, the value of collateral fell, ABCP could not be rolled, repo haircuts rose and the private liquidity puts were triggered. To provide the funding that has been agreed to via the liquidity puts, the funding providers (commercial banks) had to tap the unsecured interbank market, where the flood of bids for funding sent Libor spreads skyward.

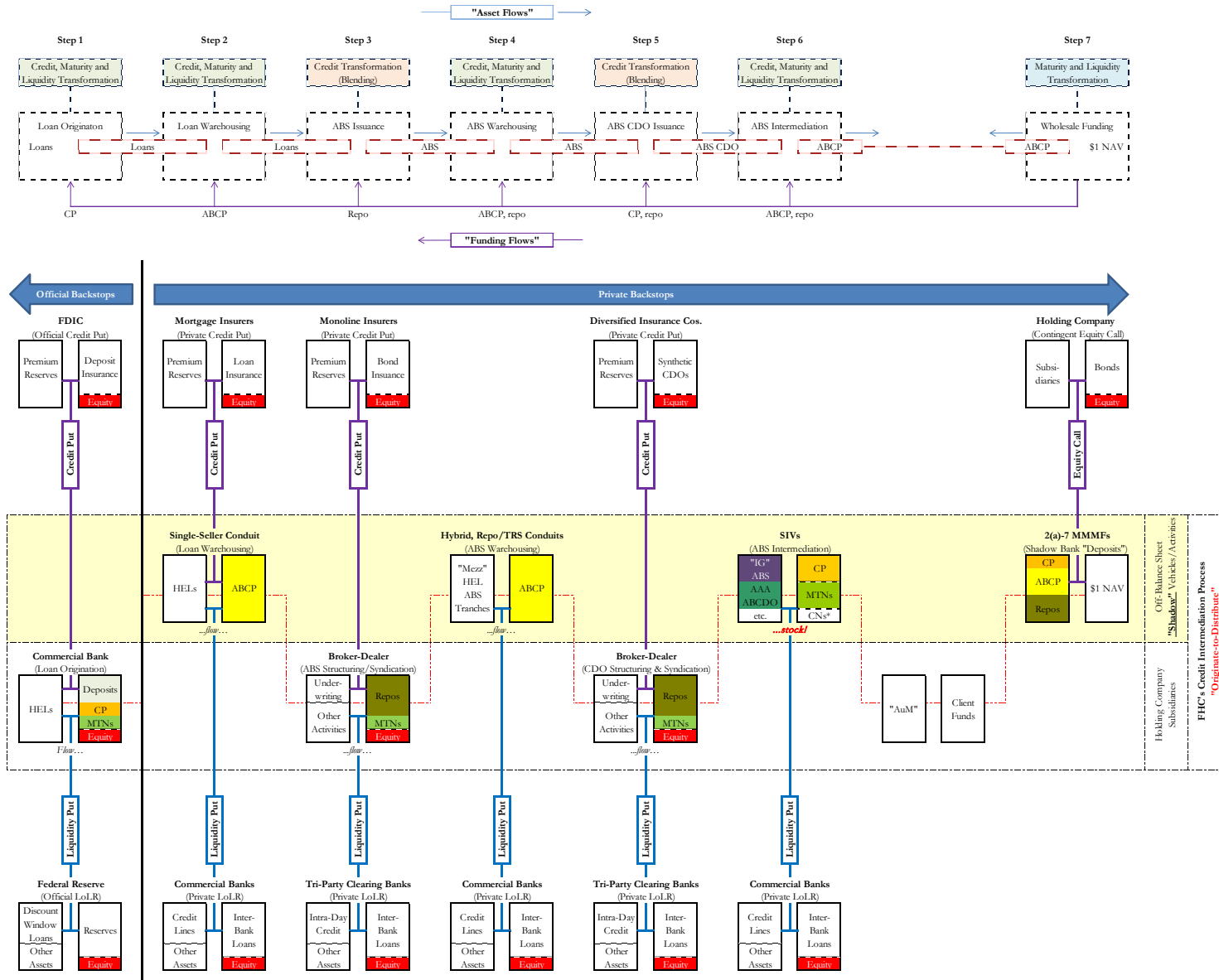

Source: Shadow Banking (Pozsar, Adrian, Ashcraft, Boesky (2010))

## Appendix 8: The Post-Crisis Backstop of the Shadow Banking System

Once private sector credit and liquidity put providers' ability to make good on their "promised" puts came into question, a run began on the shadow banking system. Central banks generally ignored the impairment of such important pillars of the shadow banking system as mortgage insurers or monoline insurers. Once the crisis gathered momentum, however, central banks became more engaged. The series of 13(3) liquidity facilities implemented by the Federal Reserve and the guarantee schemes of other government agencies essentially amount to a 360° backstop of the shadow banking system. The 13(3) facilities can be interpreted as functional backstops of the shadow credit intermediation process. Thus, CPFF is a backstop of loan origination and warehousing; TALF and Maiden Lane, LLC are backstops of the system's securities warehouses (broadly speaking); Maiden Lane III, LLC is a backstop of the credit puts sold by AIG-IP on ABS CDOs; TAF and FX swaps are backstops of and facilitated the orderly "on-boarding" of formerly off-balance sheet ABS intermediaries (many of them run by European banks who found it hard to swap FX for dollars); and finally, the funding side, PDCF is a backstop of the tri-party repo system (a "platform" where MMMFs (and other funds) fund broker-dealers and large hedge-funds) and the AMLF, MMHFF and Maiden Lane II, LLC are backstops of various forms of regulated and unregulated money market intermediaries. Furthermore, the Treasury Department's Temporary Guarantee Program of MMMFs was an additional form of backstop for money market intermediaries. This program, together with the FDIC's TLGP can be considered modern-day equivalents of deposit insurance. Only a few types of entities were not backstopped by the crisis, and some attempts to fix problems might have exacerbated the crisis. Examples include not backstopping the monolines early on in the crisis (this might have tamed the destructiveness of deleveraging) and the failed M-LEC which ultimately led to a demarcation line between bank-affiliated and standalone ABS intermediaries (such as LPFCs or credit hedge funds) as recipients and non-recipients of official liquidity. These entities failed too early on in the crisis to benefit from the liquidity facilities rolled out in the wake of the bankruptcy of Lehman Brothers, and their demise may well have accelerated and deepened the crisis, while also necessitating the creation of TALF to offset the shrinkage in balance sheet capacity for ABS from their demise.

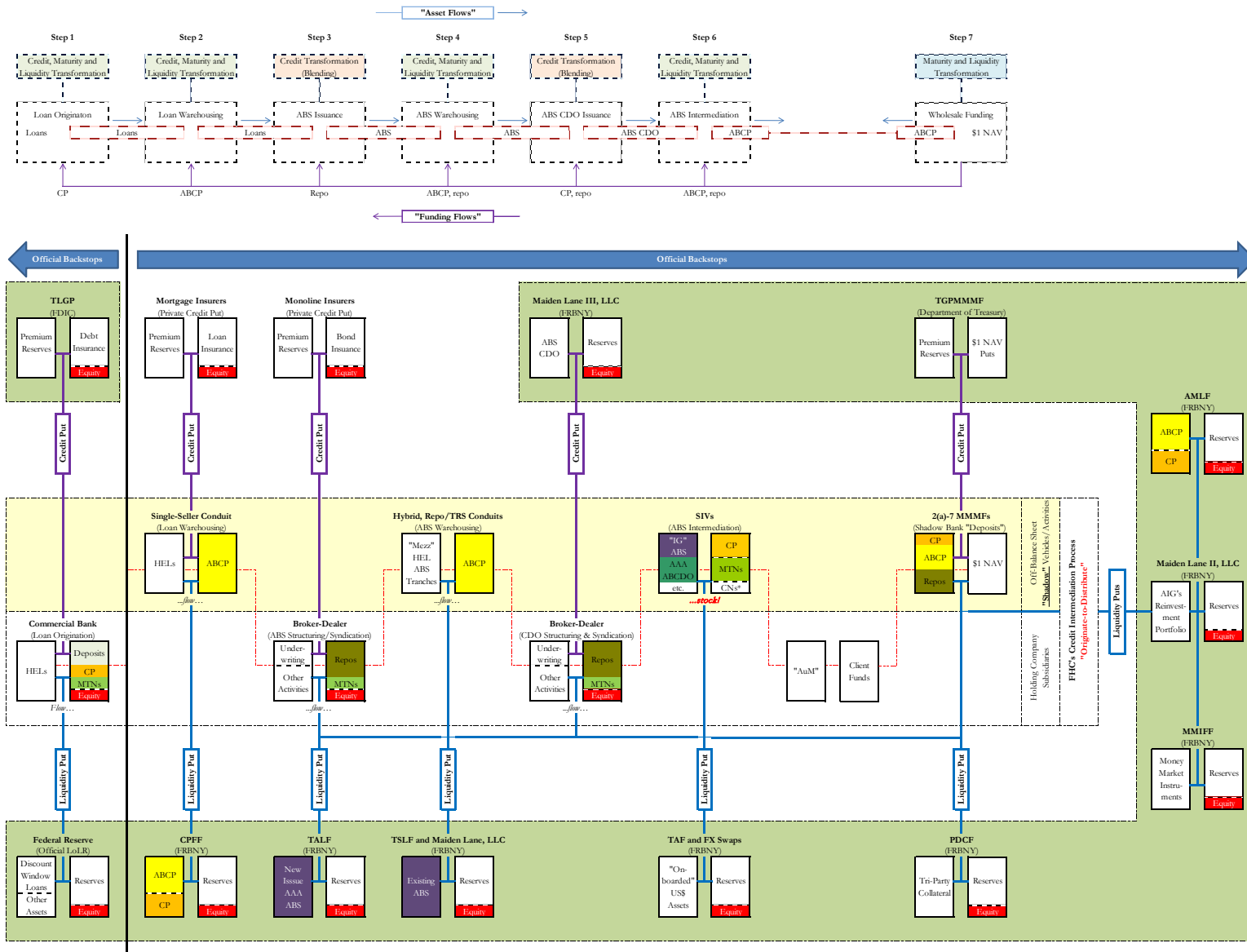

Source: Shadow Banking (Pozsar, Adrian, Ashcraft, Boesky (2010))