

12-27-1999

Adolescent substance use and adult health status

Ryan E. Spohn

University of Nebraska at Omaha, rspohn@unomaha.edu

Howard B. Kaplan

Follow this and additional works at: <https://digitalcommons.unomaha.edu/criminaljusticefacpub>

 Part of the [Criminology Commons](#)

Please take our feedback survey at: https://unomaha.az1.qualtrics.com/jfe/form/SV_8cchtFmpDyGfBLE

Recommended Citation

Spohn, R.E. and Kaplan, H.B. (1999), "Adolescent substance use and adult health status", Levy, J.A., Stephens, R.C. and McBride, D.C. (Ed.) *Emergent Issues in the Field of Drug Abuse (Advances in Medical Sociology, Vol. 7)*, Emerald Group Publishing Limited, Bingley, pp. 45-65. [https://doi.org/10.1016/S1057-6290\(00\)80004-2](https://doi.org/10.1016/S1057-6290(00)80004-2)

This Monograph is brought to you for free and open access by the School of Criminology and Criminal Justice at DigitalCommons@UNO. It has been accepted for inclusion in Criminology and Criminal Justice Faculty Publications by an authorized administrator of DigitalCommons@UNO. For more information, please contact unodigitalcommons@unomaha.edu.

ADOLESCENT SUBSTANCE USE AND ADULT HEALTH STATUS: A CRITICAL ANALYSIS OF A PROBLEMATIC RELATIONSHIP

Ryan E. Spohn and Howard .Kaplan

ABSTRACT

The intuitively appealing hypothesized relationship between drug use and physical health status is reexamined critically in a longitudinal perspective. Individuals who were first surveyed in Houston junior high schools in 1971 are followed up through personal interviews in the fourth decade of life. In addition to focusing on the baseline effect of drug use on health, we include latent constructs reflecting deviance and psychological maladjustment as theoretically relevant antecedent and mediating variables. Using structural equation models, we found a positive, significant relationship between adolescent substance use and poor physical health in adulthood. Controlling for the spurious effects of adolescent psychological health, the baseline relationship is reduced, but remains significant. However, including a latent construct for adolescent deviance in the models attenuates the baseline relationship to insignificance. On the assumption that deviance is a cause, rather than a consequence of drug use, we conclude that the general deviant lifestyle, rather than drug use per se, adversely effects physical health, even into middle adulthood.

INTRODUCTION

With increasing frequency, social scientists have hypothesized problematic out- comes of substance use including those relating *to* general adolescent development, amotivational syndrome, psychosocial dysfunction, educational impairment, deviance, mental health, and physical health (Newcomb 1987). The last outcome is arguably the most intuitively appealing of the hypothesized outcomes.

Previous research has suggested that drug use may interfere with natural

metabolic processes and harm or impair the functioning of organs or systems (Newcomb 1987). In clinical studies, alcohol and illicit drugs have been found to suppress immune system functioning, leading to susceptibility to illness and disease (Kaplan 1991). For example, clinical studies have observed the immunosuppressive effects of several illicit drugs including cocaine (Klein, Newton, and Friedman 1988), heroin (Brown, Stimmel, Taub, Krochwa, and Rosenfield 1974), and opiates (Layton et al. 1984; McDonough et al. 1980; Wybran, Appelbloom, Famaey, and Govarts 1979).

In addition, substance use may influence other lifestyle behaviors that adversely affect physical health, such as poor diet, infrequent physical exercise, or inadequate health care utilization (Donahoe and Falek 1988). Because drug use may be only one component of a general adolescent lifestyle that may have adverse effects on adult physical health, however, these other predictors must be controlled in order to prove that drug use significantly and uniquely contributes to adult adverse health outcomes (Newcomb 1987). The majority of existing studies examining the effects of adolescent substance use on physical health status exclude such control variables. Moreover, because the time-at-risk in many of the existing studies is of a short duration, the true longitudinal nature of research is called into question.

REVIEW OF THE LITERATURE

Empirical evidence from nonclinical samples suggests that adolescent drug use has a moderate effect on physical symptoms and subjective physical health (e.g., Brunswick and Messeri 1986; Castro, Newcomb, and Bentler 1988; Chen, Scheier, and Kandel 1996; Guy, Smith, and Bentler 1993; Hansell and White 1991; Kandel, Davies, Karus, and Yamaguchi 1986; Newcomb and Bentler 1987). For example, examining urban black youth, Brunswick and Messeri (1986) included intervening lifestyle variables such as educational attainment, social dysfunction, and occupational opportunity in their models. They found that inhalants and heroin use decreased physical health over a period of eight years. The addition of the lifestyle variables to the baseline models only slightly reduced

the size of the regression coefficients of cumulative inhalant and methadone use on poor health.

In a general population study, Newcomb and Bentler (1987) found that general drug use in adolescence decreased subjective physical health over a four-year period. They report only small differences between males and females in their model and include no control variables or mediating variables in the analysis.

In a subsequent examination of the relationship of drug use and physical health¹¹ using the same sample, Newcomb and Bentler (1988) control for race and ethnicity, as well as adolescent levels of the young adult outcome variables. In addition, they include mediating constructs representing "social conformity" and "social support" during adolescence (p. 72). Physical health problems were captured by a latent variable composed of three scales representing trouble with health, being unhappy with health, and health problems over the past 4 years. Accounting for the control variables and mediating constructs, general drug use was found to have a positive effect on this physical health variable.

In a similar study, Hansell and White (1991) focus on the interrelationships between substance use, psychological distress, and physical symptoms. Controlling for the effects of gender and parental education and accounting for the mediating effects of antecedent and concurrent psychological distress, they report that higher levels of general drug use increased physical symptoms over a period of three years.

Finally, Castro et al. (1988) conducted a study focusing only on cocaine use. This study does take into account the confounding influence of depression in reporting physical health status, but fails to control for other relevant characteristics such as race and gender. Castro et al. (1988) did not find a relationship between general cocaine involvement and physical health, but "times super high on cocaine" did predict more health problems over a subsequent four-year period (Castro et al. 1988, pp. 175, 177).

The previous four studies found moderate relationships between drug use and physical health, but they all have a time-at-risk of less than nine years that extends only into the subjects' early twenties. Because adolescents and young

adult; tend to be at the peak of their physical health, more severe, long-term damage to health may not become measurable until later periods of life (Chen et al. 1996). Two studies (Kandel et al. 1986; Guy et al. 1993) that utilized extended at-risk periods between adolescent substance use and health outcomes produced mixed findings. Kandel et al. (1986) studied a sample of youth contacted initially at ages 15 and 16 who were administered follow-up interviews nine years later at age 24 and 25. Their regression models include relevant control variables as well as intervening variables measuring high school dropout, education level, unemployment spells, and age at marriage. They found that marijuana use in adolescence was positively associated with the young adult outcome of being ill in bed within the last year. Moreover, the use of illicit drugs in adolescence predicted increased drug-related health problems.

A similar study was conducted by Guy et al. (1993) in which a sample originally interviewed as adolescent,; was reinterviewed at a mean age of 25.3. The models control for gender and grade point average. In addition, measures of adolescent socialization, which incorporate Hirschi's (1969) element,; of social control, moderate the effect of substance use on adult poor health. They found that adolescent substance use was significantly predictive of young adult "subjective health problems" and "substance related accidents" (Guy et al. 1993, p. 476). However, substance use was not related to subjective physical hardness, respiratory symptoms, seizure symptoms, psychosomatic symptoms, or general accidents. These findings suggest that adolescent drug use may increase subjects' reports of general feelings of ill-health. but not increase reports of actual physical symptoms.

Two final studies examine the detrimental effects of drug use extending not only through adolescence but also into early adulthood. Johnson and Kaplan (1990), modeling educational attainment as a mediating variable, found that proximate continual daily drug use did not have a direct effect on young adult physical health, but had an indirect effect (via education) on health limitations.

In a study that examines a sample composed only of males, Chen et al. (1996) found that multiple drug use up to the age of 28-29 had a direct effect on

health problems six years later. No potential intervening factors or common antecedent,; were included in these models, however, so it remains unclear if the relationship between drugs and health is unique or spurious.

Due to their interrelationships with substance use and physical health, we believe that two lifestyle factors in particular must be modeled as common antecedents in order to determine the unique effect of substance use on physical health status: psychological adjustment and deviant behavior. The existing literature examining the common associations between substance use, physical health, and these antecedent factors is discussed in turn.

Substance Use, Psychological Health, and Physical Health

Many authors suggest that psychological well-being is inextricably tied to drug use, and is thus a confounding factor in the relationship between drug use and physical health (Kandel, Kessler, and Margulies 1978; Kaplan 1975; Kaplan, Johnson, and Bailey 1988; Paton and Kandel 1978). Empirical research has verified the strong interrelationships between drug use, psychological health, and physical health (Castro et al. 1988; Joe, Garriott, and Simpson 1991; Johnson and Kaplan 1990; Hammersley, Lavelle, and Forsyth 1992; Hansell and White 1991; Zihlocki, Aidala, Hansell, and White 1991).

The relationship between drug use and psychological maladjustment is often hypothesized as reciprocal. Emotional distress may lead to drug use as individuals attempt to cope with negative self-feelings, depression, and anxiety. At the same time, however, drug use itself may impair an individual's emotional well-being because it represents a violation of internalized values and may evoke negative responses from significant others (Kaplan et al. 1988), because of the toxic effects of the drugs, or because of the unpleasant symptoms of withdrawal (Kaplan 1995).

A number of empirical studies have found a positive association between psychological maladjustment and physical health (Hansell and White 1991; Johnson and Kaplan 1990; Mechanic and Hansell 1987). These studies suggest that psychological maladjustment may directly contribute to physical illness by weakening the immune system. Moreover, psychological maladjustment can

influence one's perceptions and reporting of physical well-being. Because perceptions of physical health are only one aspect of an individual's overall assessment of health and well-being, it is important to control for the influence of mental health on self-reports of physical health.

Substance Use, Delinquency, and Physical Health

A correlation between substance use and other forms of deviance is frequently observed in the literature (for reviews of empirical research see Elliot, Huizinga, and Ageton 1985, p. 12; Leukefeld et al. 1998). For example, McBride and McCoy (1993) cite evidence of drug use among arrestees and nonincarcerated delinquents ranging from a low of 47 percent in New Orleans to a high of 81 percent in Manhattan (p. 265). Substance use and general deviance are often seen to share common antecedents, such as an underlying tendency to engage in short-term pleasures combined with a lack of self-restraint in pursuing such pleasures (Gottfredson and Hirschi 1990; Kaplan 1995). An empirical paper examining this subject found that the common risk factors of adolescent drug use and general delinquency stem from the various domains of personality, family, peer, ecology, and acculturation (Brook et al. 1998).

In addition to the relationship of general deviance and drug use due to common antecedents, drug use and abuse have a causal relationship with subsequent violent and nonviolent delinquency. For instance, drug use often leads to an expensive addiction, and users are often pressured into committing crimes to support their habit. One study reported that over 40 percent of the total income of a sample of street-drug users was generated through criminal activity (Johnson et al. 1985). Moreover, persons involved in the illicit drug trade have no access to the law to protect their transactions, so users and sellers often resort to violence or the threat of violence to control their associates (Goldstein 1989; Johnson, Williams, Dei, and Sanabria 1990).

Both violent and nonviolent delinquency are likely to be associated with subsequent physical health problems. Delinquent adolescents may be especially prone to accidents and illness due to excessive risk-taking behaviors. Persons

engaging in high-risk behaviors might not pursue strategies to prevent illness or injury, and may be less likely to utilize medical services. Moreover, delinquents (especially those involved in the drug trade) are inclined to be victims, as well as perpetrators, of violence.

The Present Study

Because much of the existing literature consists of studies with insufficient control variables and/or a short time-at-risk, additional research is necessary to determine the long-term, unique effect of adolescent drug use on adult health status. In particular, it is important to examine the influence of common antecedents (such as race/ethnicity, etc.) which confound the relationship between drugs and health. The current study will examine the effects of adolescent drug use on subjects' adult health status nearly 25 years later. We include control variables for race and gender as well as theoretically relevant antecedent and intervening constructs reflecting psychological maladjustment and deviance. The inclusion of these constructs also allows a more complete understanding as to whether the relationship between adolescent drug use and adult physical health problems is "true" or spurious. Finally, we employ structural equation modeling techniques which allow simultaneous estimation of models composed of latent variables and the separation of measurement error from the true, error-free aspects of the measured variables reflecting the latent constructs.

The effects of adolescent deviance and mental health status are examined in separate, theoretically developed models in order to determine the effect of each construct. Due to the confusion over the causal direction of the relationship between psychological adjustment and substance use, the current research will model psychological maladjustment as both a common antecedent and an intervening variable in the relationship between adolescent drug use and adult physical health status. Similarly, in order to consider the possibly spurious effects of a delinquent lifestyle, we model delinquency as both a common antecedent and an intervening variable in the relationship between adolescent drug use and adult physical health status.

METHOD

Sample and Data Collection

The data for this analysis were drawn from the first and fifth waves of a panel study of all of the seventh grade students in a random sample of one-half of the 36 junior high schools of the Houston Independent School District (Time 1) in 1971. The first wave was collected by self-administered questions in the students' classes in the spring of 1971 when the subjects' modal age is 13 years. Of the 9,335 subjects composing the target sample, 7,618 students (82%) returned usable questionnaires at Time 1. The subjects were administered Time 2 and Time 3 in the eighth and ninth grades, respectively, and during the 1980s (Time 4) as young adults through personal household interviews. Finally, the subjects were interviewed in the 1990s (Time 5) during their fourth decade of life. The subjects average age at Time 5 is about 37 years. In order to determine the effects of adolescent drug use over a substantial length of time, the current study analyzes data from Time 1 and Time 5. Variables were drawn using list-wise deletion of missing values, therefore, the sample size for each model may vary. The percentage distributions of the subjects returning questionnaires at the first testing according to selected demographic characteristics are displayed in Table 1.

Table 1. Selected Demographic Characteristics of the Sample

Characteristics	Percentage
Gender	
Male	49.5
Female	50.5
Race/Ethnicity	
White-Anglo	60.0
Black	27.2
Mexican-American	10.6
Other	2.2
Father's Education	
Did not complete elementary school	5.7
Completed elementary school	13.4
Graduated high school	32.0
Graduated college	48.9
Age	
11 or younger	3.4
12	33.6
13	47.0
14 or older	16.0
Religion	
Protestant	62.2
Catholic	20.4
Jewish	2.6
Other non-Christian	4.0
Unaffiliated	9.2

Analysis

We estimated the causal models using raw data of self-reported variables as input into the computer program EQS (Bentler and Wu 1993). Assuming that the joint distribution of the variables is approximately multivariate normal, this program provides consistent and asymptotically efficient maximum likelihood estimates of all identified model parameters. Each model consists of independent and dependent variables, some of which are observed and some of which are unobserved latent constructs. The specified model represents effects between independent and dependent variables among which there exists an hypothesized causal structure. This model is termed the structural equation model, which represents the hypothesized causal relationships among the exogenous and endogenous variables as regression coefficients. The parameters of the equations representing the measurement model and the causal model are estimated simultaneously as a single system.

Structural equation modeling is a very useful technique for data analysis in the social sciences because it provides a method of separating measurement error from the true, error-free aspects of the measured variables reflecting the latent constructs. As a result, the latent factors represent only the commonality of the association among the observed indicators as reflected in the intercorrelations among these measured variables (Newcomb 1990).

Variables

Independent Variables

Substance Use. A latent construct of adolescent substance use is composed of three measured variables of self-reports of: (1) having used wine, beer, or liquor two or more times in the last week; (2) having used narcotic drugs within the last month; and (3) having smoked marijuana within the last month.

Antecedent and Mediating Variables

Psychological Maladjustment. A single factor reflecting an overall construct of psychological maladjustment during adolescence is measured with three cumulative scales. These measures reflect symptoms and expressions of depression, anxiety, and

self-derogation. The depression scale represents depressed affect and absence of life-satisfaction. The scale representing anxiety includes responses such as nervousness, ability to keep one's mind on things, and biting fingernails. Finally, the self-derogation scale represents self-rejecting attitudes. The component items appear in the Appendix.

Deviance. Adolescent deviance is measured with a latent variable indicated by two scales. A scale representing nonviolent deviance taps behaviors such as theft, skipping school, and joy-riding in a car without the owner's knowledge. A violent deviance scale reflects behaviors such as gang fighting, fist fighting, breaking and entering, and using force to damage or destroy public property. The specific items are presented in the Appendix.

Dependent Variables

Physical Health. Poor physical health in the fourth decade of life is reflected by a latent construct with four indicator variables. The first indicator variable reflects unemployment resulting from medical impairments. The second indicator measures whether or not the respondent stayed in bed all day due to illness any time within the last 12 months. A third indicator reflecting recent physical symptoms is a nine-item scale measuring maladies such as sore throat or colds, headaches, and stomach flu over the past 30 days. Finally, the fourth indicator reflects perceived subjective health. This question asks respondents to compare their own health to other persons of the same gender and age. These items are presented in the appendix.

Control Variables

It is assumed that both race and gender will have confounding effects on the relationship between drug use and health. As a result, measures for each of these characteristics are included in the structural equation models. *Race* is modeled as an exogenous control variable. It is coded as a dichotomy (1 = nonwhite and others, 0 = white). *Gender* is also modeled as an exogenous control variable, with males coded as 1 and females coded as 0.

RESULTS

The analyses are conducted in two stages. First, we measure the effect of antecedent drug and alcohol use at Time 1 (when the youth were in the seventh grade), on physical well-being at Time 5 (middle adulthood), controlling for both race and gender. This analysis will determine if, controlling for race and gender, adolescent substance use has an impact on adult health symptoms over two decades later.

The second stage of the analysis involves the estimation of models in which the theoretically relevant mediating variables are added to the base-line model estimated in the first stage. Due to the interrelationships between substance use, psychological maladjustment, deviance, and physical health, it is necessary to determine if the inclusion of these mediating variables attenuates or reduces to nonsignificance the relationship between adolescent substance use and adult health status, whether because of their common antecedent or mediating status. We consider in turn the results relating to the baseline relationship between substance use and adult poor health and the results relating to the theoretically relevant antecedent/mediating variables.

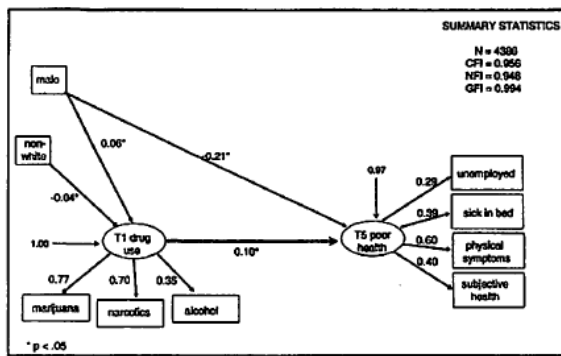

Figure 1. Baseline Model of the Effect of Adolescent Substance Use on Adult Poor Health

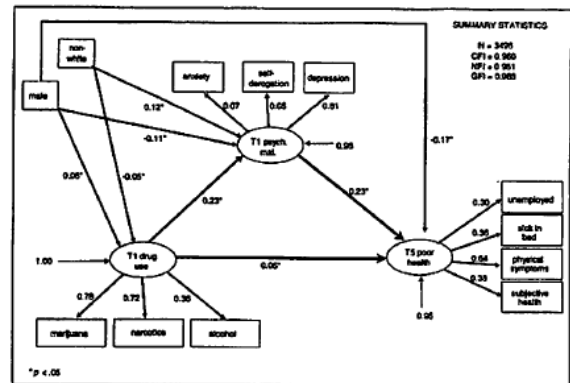

Figure 2. Psychological Maladjustment as a Mediating Variable in the Relationship between Adolescent Substance Use and Adult Poor Health

Adolescent Substance Use and Adult Health Status

The baseline model shown in Figure 1 provides the standardized coefficients expressing the relationship between the latent construct for adolescent substance use and a latent construct reflecting self-reported poor health in adulthood. Controlling for common antecedents of race/ethnicity and gender, a modest but statistically significant positive relationship exists between

adolescent substance use and adult health status ($\beta = 0.10, p \leq .001$). In addition, the negative coefficient for gender suggests that males are less likely than females to report poor physical health status in adulthood ($\beta = -0.21, p \leq .001$). The effects of race and gender on adolescent drug use are moderate in magnitude, but significant. The overall fit of this model is good, with a comparative fit index value of 0.956. A CFI value greater than .90 indicates an acceptable fit of the model to the data (Byrne 1994).

This baseline model is noteworthy because it provides evidence that adolescent substance use has negative effects on physical health, even into the fourth decade of life. Previous studies have focused primarily on adverse effects of adolescent drug use extending only into the late teenage years or early adulthood. However, in order to establish that this relationship is causal rather than a spurious outcome of common correlates of substance use and poor health, in the subsequent analysis we control for variables that may theoretically serve as common antecedents or intervening variables.

Antecedent/Mediating Variables

Psychological Maladjustment

The literature provides evidence of the interrelationships that exist between self-reported psychological health, physical health, and substance use. We believe that perceptions of poor psychological health account, in whole or in part, for the observed temporal relationship between substance use and reports of physical health symptoms. It is unclear, however, whether substance use increases perceptions of psychological maladjustment or if psychological maladjustment increases substance use as individuals attempt to cope with the disturbance. Due to this uncertainty, we model psychological maladjustment as both an intervening variable and a common antecedent.

The model presented in Figure 2 includes a latent construct for psychological maladjustment in adolescence as an intervening variable in the relationship between adolescent substance use and poor adult health. We assume that drug use impairs individuals' emotional well-being, which in turn influences perception of physical

health. The fit statistics provide evidence that the model fits the data well (CFI = 0.960). Although the magnitude of the direct effect of drug use on health is attenuated as compared to the baseline model, a significant ($\beta = 0.06$, $p \leq .05$) direct relationship persists. Thus, controlling for psychological well-being, adolescent drug use has an independent, unique effect on adult health.

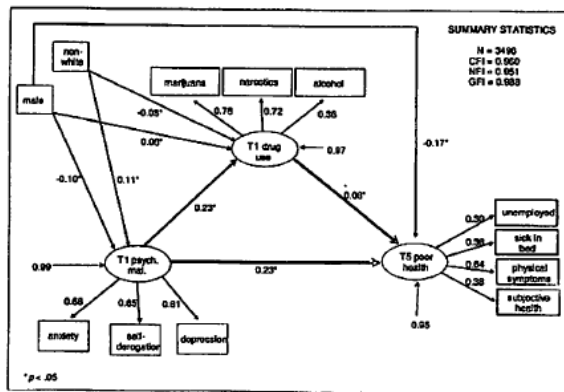

Figure 3. Psychological Maladjustment as a Common Antecedent in the Relationship between Adolescent Substance Use and Adult Poor Health

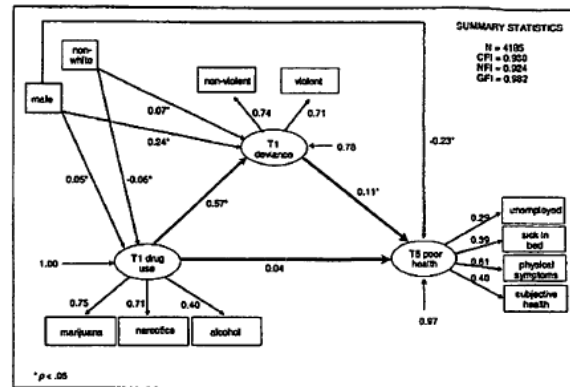

Figure 4. Adolescent Deviance as a Mediating Variable in the Relationship between Adolescent Substance Use and Adult Poor Health

Adolescent drug use also has a significant indirect effect ($\beta = 0.05, p \leq .001$) on health through the effect of psychological maladjustment. Consistent with the literature, psychological maladjustment has a strong positive association with reports of poor physical health ($\beta = 0.23, p \leq .001$). Thus, persons who report symptoms of depression, anxiety, and negative self-feelings in adolescence are more likely to report poor physical health in adulthood. Moreover, females and minorities were more likely to report symptoms of psychological maladjustment.

In Figure 3, we model adolescent psychological maladjustment as a common antecedent to substance use and adult health status. This model is based on the assumption that adolescents use illicit substances in an attempt to cope with the strains of psychological distress. Similar to the previous model, adolescent drug use has a unique, significant effect on poor adult health ($\beta = 0.06, p \leq .05$). Moreover, psychological maladjustment in adolescence has a strong effect on reports of physical health over 20 years later ($\beta = 0.23, p \leq .001$).

Deviance

Due to the associations between illicit substance use and other deviant behaviors, we have reason to believe that the observed temporal relationship between substance use and reports of physical health symptoms may be spurious. Rather than a unique effect of drug use, poor physical health may be a result of the general lifestyle of delinquents, including excessive risk-taking, the absence of preventative strategies to

prevent illness and injury, and an inclination toward violent behaviors. Because of the lack of agreement in the literature as to the temporal relationship between drug use and other deviance, we model adolescent deviance as both a common antecedent and an intervening variable in the relationship between adolescent substance use and adult health.

The model presented in Figure 4 includes a latent construct for adolescent deviancy as an intervening variable in the relationship between adolescent substance use and poor adult health. With this specification, we assume that illicit substance use results in involvement in other deviant behaviors. The overall fit of the model is acceptable (CFI = 0.930). The specification of an effect of substance use on deviance attenuates the direct effect of illicit substance use on physical health status to nonsignificance ($\beta=0.04$, n.s.). Any effect of drug use on health is indirect, via deviance. The latent construct reflecting adolescent deviance has a significant, positive effect on adult health status ($\beta = 0.11$, $p :5 .01$). Adolescents who engage in deviant behaviors are more likely to report poor physical health in adulthood. It appears that a general deviant lifestyle has a detrimental effect on adult health. With deviance modeled as an intervening variable, adolescent substance use does have a significant *indirect* effect on adult physical health through adolescent deviance ($\beta = 0.07$, $p S .01$).

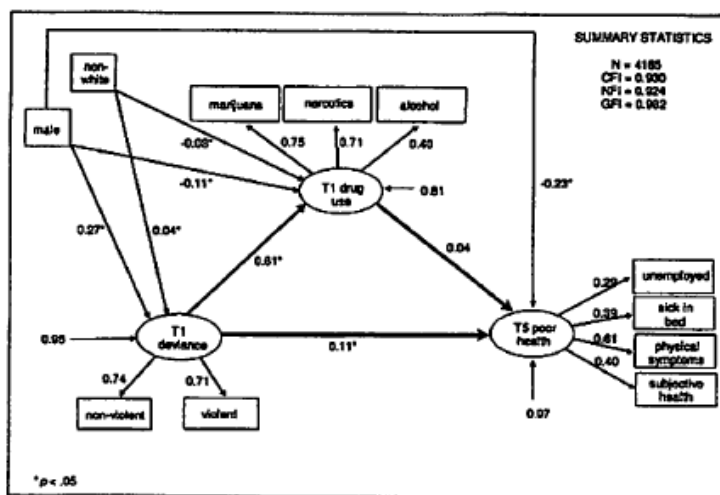

Figure 5. Adolescent Deviance as a Common Antecedent in the Relationship between Adolescent Substance Use and Adult Poor Health

Examining the control variables, we find that males are much more likely to report deviant acts in adolescence. The variable representing nonwhites has a moderate positive effect on deviance.

In Figure 5, adolescent deviance is modeled as a common antecedent of substance use and adult poor health. This model is based on the more plausible assumption that engaging in other forms of deviant activity influences the adoption of illicit drug use. Similar to the previous model, the relationship between adolescent substance use and adult physical health is attenuated to nonsignificance. The latent construct representing violent and nonviolent deviance, however, has a significant direct effect on physical health outcomes over 20 years later ($\beta = 0.11, p < .01$).

DISCUSSION

Although a causal relationship between adolescent drug use and adult physical health status is intuitively appealing, much of the current research examining this relationship inadequately specifies the mediating mechanisms through which this process occurs. Moreover, some studies fail to include appropriate control variables that are necessary to determine if the hypothesized relationship between drugs and physical health is "true" or spurious. Finally, the short time-at-risk of much of the current research creates doubts regarding the true longitudinal nature of the analyses.

This study addresses these concerns by providing a lengthy follow-up period and estimating numerous models to examine the various mechanisms that might account for the relationship between adolescent drug use and adult health. These theoretically developed models provide a detailed analysis of the impact of individual latent constructs that mediate the relationship between drugs and health. In contrast, many previous studies omitted relevant antecedent or intervening variables completely. Including psychological health status and deviance in separate models allows both an examination of the impact of each variable on adult health and an analysis of the mediating and/or common antecedent effect of each

variable on the relationship between adolescent substance use and adult health status.

In the current study, we estimated a model that examined the relationship between adolescent substance use and self-reported physical health symptoms more than 20 years later. Although the existing literature has commonly found a relationship between drug use and physical health, this study extends our knowledge of the impact of adolescent behaviors over the life course. In the baseline model controlling for race and gender, adolescent substance use was found to have a significant, albeit modest, detrimental effect on adult health status. This relationship persisted when we controlled for the mediating effects of psychological maladjustment. Moreover, when psychological maladjustment was modeled as an intervening construct (see Figure 2), adolescent substance use had a significant, indirect effect (in addition to the direct effect) on adult health status through psychological maladjustment.

In contrast, including a latent construct reflecting adolescent deviance in the model attenuated the baseline relationship to nonsignificance. However, in a model presenting adolescent deviance as an intervening construct (see Figure 4), adolescent substance use had a significant, indirect effect on adult health through this construct. Thus, a "true" effect of drugs on health depends on assumptions about the causal relationship between drug use and other forms of deviance.

Because the incorporation of psychological maladjustment to the baseline model did not entirely mediate the effects of the risk factor, we might have concluded that substance use has a detrimental impact on physical health above and beyond its indirect effects through psychological health status. That is, subjects who used illicit substances in adolescence do not simply report adult physical health problems due to the existence of subsequent psychological distress. Using structural equation modeling, we are able to determine the unique relationships of adolescent substance use to both psychological and physical health. Our results provide partial support for Hansell and White's (1991) assertion that adolescents may not be able to distinguish between psychological distress and physical symptoms as readily as adults (p. 298). Because our cohort had reached their

middle thirties at the time adult health status was recorded, they may have reached an age at which they could more clearly distinguish between psychological and physical symptoms.

However, with the inclusion of deviance as a common antecedent and mediating variable, the current study provides support for the hypothesis that a general deviant lifestyle is detrimental to long-term health and casts doubt on the hypothesis that drug use has a unique effect on health, net of the association between drug use and deviant lifestyle. Substance users as delinquents may become victims of violence due to their interactions with deviant peers or through violence associated with the illicit drug trade. Persons leading a deviant lifestyle may be more prone to accidents due to excessive risk-taking behaviors. Moreover, such persons may neglect their physical health by failing to utilize medical services or by ingesting an unhealthy diet. Through these various processes, both delinquency and illicit drug use become inextricably linked to subsequent health problems. Bad health habits associated with a deviant lifestyle in adolescence may become learned and replicated throughout the lifecycle. Nevertheless, on the assumption that drug use influences subsequent deviance, adolescent drug use may be understood to have an indirect impact (via delinquent lifestyle) on subsequent health status.

New directions in research on the consequences of substance (ab)use should continue to critically reexamine the facile conclusions regarding such consequences by specifying common antecedents that might render such conclusions spurious. Frequently, such reexamination involves a determination of the true causal sequences between putative antecedents or these consequences. In the analysis reported above, the causal relationship between drug use and other forms of deviance is a case in point. Whether the adolescent drug use is thought to have an indirect effect on adult health status or the association between drug use and health is believed to be the spurious outcome of their common association with antecedent deviance depends on the determination of the temporal relationship between drug use and deviance. In any case, once it is determined that a causal relationship between drug use and a putative consequence exists, we may then

examine the nature of the intervening processes and moderation circumstances that elaborate the theoretically informed relationship.

APPENDIX

DRUG USE, WAVE I

Alcohol:

Within the last week have you used wine, beer, or liquor more than two times?

Marijuana:

Within the last month did you smoke marijuana (grass)?

Narcotic drugs:

Within the last month did you take narcotic drugs?

PSYCHOLOGICAL MALADJUSTMENT, WAVE I

Depression (depressed affect and somatic symptoms of depression, $a = 0.605$):

Do you wish you could be as happy as others seem to be?

Within the last year did you think about or threaten to take your own life?

Would you say that most of the time you feel in good spirits? (reverse code)

Within the last year did you attempt to take your own life?

Do you often feel downcast and dejected?

Do you often lose track of what you were thinking? Do you get a lot of fun out of life? (reverse code)

On the whole, would you say you are a fairly happy person? (reverse code)

Anxiety (panic, phobic, and behavioral responses, $a = 0.734$):

Are you often bothered by nervousness?

Are you often bothered by shortness of breath when not exercising or working hard?

Are you often bothered by bad dreams?

Do you often have trouble getting to sleep or staying asleep? Do you often have difficulty keeping your mind on things?

Are you often bothered by your hands sweating so that they feel damp and clammy?

Do you often bite your fingernails!

Are you often bothered by pressures or pains in your head?

Do you often have trouble sitting still for a long time?

I worry a lot more now than I used to. (1 = true, 0 = false)

I get nervous when things aren't just right? (1 = true, 0 = false)

Self-derogation (a= 0.613):

I wish I could have more respect for myself. (1 = true, 0 = false) On the whole, I am satisfied with myself. (0 = true, 1 = false)

I feel I do not have much to be proud of. (1 = true, 0 = false)

All in all, I am inclined to feel that I am a failure. (1 = true, 0 = false) I take a positive attitude towards myself? (0 = true, 1 = false)

At times I think that I am no good at all. (1 = true, 0 = false)

I certainly feel useless at times. (1 = true, 0 = false)

DEVIANCE, WAVE I

Violent deviance (a= 0.464):

Within the last year did you carry a razor, switch blade, or gun as a weapon?

Within the last year did you start a fist fight?

Within the last year did you take part in gang fights?

Within the last year did you use force to get money or valuables from another person?

Within the last year did you break into and enter a home, store or building?

Within the last year did you damage or destroy public or private property on purpose that didn't belong to you?

Within the last year did you beat up on someone who had not done anything to you?

Nonviolent deviance (a= 0.575):

Within the last year did you take things worth between \$2 and \$50 that didn't belong to you?

Within the last year did you take little things (worth less than \$2) that didn't belong to you?

Within the last year did you skip school without an excuse?

Within the last year did you take things from someone else's desk or locker at school without permission?

Within the last year did you take a car for a ride without the owner's knowledge?

Within the last year did you take things worth \$50 or more that didn't belong to you?

POOR PHYSICAL HEALTH, WAVE 5

Unemployment:

Tell me if the following were reasons for your not working: A medical reason!

Sick in Bed:

Were there any days during the last 12 months when you stayed in bed all or most of the day because you weren't feeling well?

Recent Symptoms (ex= 0.537):

During the past 30 days, did you have:

A cough, without fever, which lasted at least three weeks?

A sore throat or cold, with fever, lasting more than three days! Stiffness, pain or swelling of joints lasting more than two weeks? Shortness of breath with light exercise or light work?

Chest pain when exercising? Headaches almost every day?

Loss of consciousness, fainting, or passing out?

Acid indigestion or heartburn after eating many different types of foods?

Stomach flu or virus with vomiting or diarrhea?

Subjective Health:

Compared to most other people your age and sex, do you think your health is:

1. better,
2. about the same, or
3. worse?

ACKNOWLEDGMENT

This work was supported by research grant (ROI DA02497 and ROI DA10016) and by Research Science Award (KOS DA00136) to the second author from the National Institute on Drug Abuse.

REFERENCES

- Bentler, P.M. and E.J.C. Wu. 1993. *EQS Program Manual*. Los Angeles: BMDP Statistical Software.
- Brook, J.S., M. Whiteman, E.B. Dalka, P.T. Win, and M.D. Gursen. 1998. "Similar and Different Pre- cursors to Drug Use and Delinquency among African Americans and Puerto Rican." *The Journal of Genetic-Psychology* 159(1): 13-29.
- Brown, S.W., B. Stimmel, R.N. Taub, S. Krochwa. and R.E. Rosenfield. 1974. "Immunological Dysfunction in Heroin Addicts." *Archives of Internal Medicine* 134(6): 1001-1006.
- Brunswick, A.F. and P. Messeri. 1986. "Drugs, Lifestyle, and Health: A Longitudinal Study of Urban Black Youth." *American Journal of Public Health* 76(1): 52-57.
- Byrne, U.M. 1994. *Structural Equation Modeling with EQS and EQS/Windows: Basic Concepts, Application, and Programming*. Thousand Oaks, CA: Sage.
- Castro, F.G., M.D. Newcomb, and P.M. Bentler. 1988. "Depression and Poor Health as Antecedents and Consequences of Cocaine Use." *Psychology and Health* 2(2): 157-186.
- Chen, K., L.M. Scheicr. and D.B. Kandel. 1996. "Effects of Chronic Cocaine U c on Physical Health: A Prospective Study in a General Population Sample." *Drug and Alcohol Dependence* 43(1 - 2): 23-37.
- Donahoe, R.M. and A. Falek. 1988. "Neruroimmunomodulation by Opiates and Other Drugs of Abuse: Relationship to HIV Infection and AIDS." Pp. 145-158 in *Psychologic. Neuropsychiatric, and Substance Use Aspects of AIDS*, Vol. 44, edited by T.P. Uridgc. A.F. Mirsky. And f.K. Goodwin. New York: Raven Press.
- Elliot, D.S., D. Huizinga, and S.S. Ageton. 1985. *Explaining Delinquency 1111tl Drug Use*. Beverly Hills, CA: Sage.
- Goldstein, P.J. 1989. "Drugs and Violent Crime." Pp. 16-48 in *Pathway., to Criminal*

- Violence*. Edited by N.A. Weiner and M.E. Wolfgang. Newbury Park. CA: Sage.
- Gottfredson, M.R. and T. Hirschi. 1990. *A General Theory of Crime*. Stanford, CA: Stanford University Press.
- Guy, S.M., G.M. Smith, and P.M. Bentler. 1993. "Adolescent Socialization and Use of Licit and Illicit Substances: Impact on Adult Health." *Psychology and Health* 8(6): 463-487.
- Hammersley, R., T.L. Lavelle, and A.J.M. Forsyth. 1992. "Adolescent Drug Use, Health, and Personality." *Drug and Alcohol Dependence* 31(1): 91-99.
- Himmelfarb, S. and H.R. White. 1991. "Adolescent Drug Use, Psychological Distress, and Physical Symptoms." *Journal of Health and Social Behavior* 32(3): 288-301.
- Hirschi, T. 1969. *Causation of Delinquency*. Berkeley: University of California Press.
- Joe, G.W., J.C. Ciarriou, and D.D. Simpson. 1991 "Physical Symptoms and Psychological Distress among Inhalant Users." *Hispanic Journal of Behavioral Sciences* 13(3): 297-314.
- Johnson, D., P.J. Goldstein, E. Preble, J. Schmeidler, D.S. Lipton, and T. Miller. 1985. *Taking Care of Business The Economics of Crime and Heroin Abusers*. Lexington, MA: Lexington Books.
- Johnson, R. J., T. Williams, K.A. Dei, and H. Sanabria. 1990. "Drug Abuse in the Inner City: Impact on Hard-Drug Users and the Community." Pp. 9-67 *Drugs and Crime*, edited by M. Tonry and J.Q. Wilson. Chicago: The University of Chicago Press.
- Johnson, R.J. and H.D. Kaplan. 1990. "Stability of Psychological Symptoms: Drug Use Consequences and Intervening Processes." *Journal of Health and Social Behavior* 31(3): 277-291.
- Kandel, D.B., M. Davies, D. Karus, and K. Yamaguchi. 1986 "Life Consequences in Young Adulthood of Adolescent Drug Involvement." *Archives of General Psychiatry* 43(8): 746-754.
- Kandel, D.B., R.C. Kessler, and R.Z. Margulies. 1978. "Antecedents of Adolescent Initiation into Stages of Drug Use: A Developmental Analysis." *Journal of Youth and Adolescence* 7(1): 13-40.
- Kaplan, H.D. 1975. *Self-Attitudes and Deviant Behavior*. Pacific Palisades. CA: Goodyear.
- Kaplan, H.B. 1991. "Social Psychology of the Immune System: A Conceptual Framework

- and Review of the Literature." *Social Science & Medicine* 33(8): 909-923.
- Kaplan, H.D. 1995. "Drugs, Crime, and Other Deviant Adaptations." Pp. 3-46 in *Drugs, Crime, and Other Deviant Adaptations: Longitudinal Studies* edited by H.B. Kaplan. New York: Plenum Press.
- Kaplan, H.B. • R.J. Johnson. and C.A. Bailey. 1988. "Explaining Adolescent Drug Use: An Elaboration Strategy for Structural Equations Modeling." *Psychiatry* 51(2): 142-163.
- Klein, T.W. • C.A. Newton. and H. Friedman. 1988. "Suppression of Human and Mouse Lymphocyte Proliferation by Cocaine." Pp. 139-143 in *Psychological, Neuropsychiatric, and Substance Abuse Aspects of AIDS* Vol. 44. edited by T.P. Bridge, A.F. Mirsky, and F.K. Goodwin. New York: Raven Press.
- Layon, J. • A. Idris, M. Warzynski, R. Shere, D. Brauner, O. Patch, D. McCulley, and P. Orris. 1984. "Altered T-Lymphocyte Subsets in Hospitalized Intravenous Drug Abusers." *Archives of Internal Medicine* 144(7): 1376-1380.
- Leukfeld, C.G., T.K. Logan, R.R. Clayton, C. Martin, R. Zimmerman, A. Cattarello, R. Milich, and D. Lynam. 1998. "Adolescent Drug Use, Delinquency, and Other Behaviors." Pp. 98-128 in *Delinquent Violent Youth: Theory and Interventions*, edited by T.P. Gullotta, G.R. Adams, and R. Montemayor. Thousand Oaks, CA: Sage.
- McBride, D.C and C.11. McCoy. 1993. "The Drugs-Crime Relationship: An Analytical Framework." *The Prison Journal* 73(3&4): 257-278.
- McDonough, R.J., J.J. Madden, A. Falck, D.A. Shafer, M. Pline, D. Gordon, P. Ilokos, J.C. Kuehnle, and J. Mendelson. 1980. "Alteration of T and Null Lymphocyte Frequencies in the Peripheral Blood of Human Opiate Addicts: In Vivo Evidence of Opiate Receptor Sites on T Lymphocytes." *Journal of Immunology* 125(6): 2539-2543.
- Mechanic, D. and S. Hansell. 1987. "Adolescent Competence, Psychological Well-Being, and Self-Assessed Physical Health." *Journal of Health and Social Behavior* 28(4): 364-374.
- Newcomb, M.D. 1987. "Consequences of Teenage Drug Use: The Transition from Adolescence to Young Adulthood." *Drug & Society* 1(4): 25-60.
- Newcomb, M.D. 1990. "What Structural Equation Modeling can Tell Us about Social

- Support." Pp. 26-63 in *Social Social: An International View*, edited by D.R. Sarason, I.G. Sarason, and G.R. Pierce. New York: John Wiley and Sons.
- Newcomb, M.D. and P.M. Bentler. 1987. "The Impact of Late Adolescent Substance Use on Young Adult Health Status and Utilization of Health Services: A Structural-Equation Model over Four Years." *Social Science & Medicine* 24(1): 71-82.
- Newcomb, M.D. and P.M. Bentler. 1988. "Impact of Adolescent Drug Use and Social Support on Problems of Young Adults: A Longitudinal Study." *Journal of Abnormal Psychology* 97(1): 64-75.
- Paton, S.M. and O.B. Kandel. 1978. "Psychological Factors and Adolescent Illicit Drug Use: Ethnicity and Sex Differences." *Adolescence* 13(50): 187-200.
- Wybran, J., T. Appclboom, J.P. Famacy, and A. Govaens. 1979. "Suggestive Evidence for Receptors for Morphine and Methionine-Enkephalin on Normal Human Blood T Lymphocytes." *Journal of Immunology* 123(3): 1068-1070.
- Zablocki, B., A. Aidala, S. Hansell, and H.R. White. 1991. "Marijuana Use, Introspectiveness, and Mental Health." *Journal of Health and Social Behavior* 32(1): 65-79.