

Testing of Palm Oil-Based Electric Power Transformer Insulation Oil as a Renewable Energy Source

Hendri^{1*}, Yanuar Zulardiansyah Arief², Abdul Syukur³

¹ Electro Engineering, Faculty of Engineering, Universitas Negeri Padang, 25132, Indonesia

² Electro Engineering, Faculty of Engineering, Universitas Malaysia Sarawak, 94300, Malaysia

³ Faculty of Engineering, Universitas Diponegoro, 50275, Indonesia

*Corresponding author, e-mail: hendri@ft.unp.ac.id

Received 10th Jan 2024; 1st Revision 24th Jan 2023; 2nd Revision 11th Feb 2023; Accepted 26th Feb 2023

DOI: doi.org/10.24036/jptk.v6i1.32323

ABSTRACT

Reducing petroleum resources and environmental problems, alternative insulating oils with biodegradable characteristics have become an alternative. Esterification of palm-based oil is expected to provide better and optimum electrical properties. The esterification of palm oil will be carried out as a test sample and observed for its electrical, physical and chemical properties such as PD characteristics, breakdown voltage, dissipation factor, viscosity, flash point, etc. The effect of thermal aging on oil samples will also be carried out to simulate real situations in power transformer applications. Then after obtaining the best formulation from the sample it will be used as insulating oil in electric power transformers (100kVA). The purpose of this research is to apply esterified palm oil as an electric power transformer oil. The method used in this research includes field research. Field research includes taking oil samples, measuring the breakdown voltage of transformer oil, and the color of transformer oil. The results obtained are insulating oil for electric power transformers based on palm oil. Palm oil has the advantage of being an environmentally friendly, biodegradable and renewable oil compared to the transformer oil used today which is based on petroleum. With the realization of transformer oil based on palm oil, it is hoped that it can provide great economic opportunities for Indonesia as one of the largest palm oil producers in the world and can also provide added value and increase the competitiveness of the palm oil industry in the future.

Keywords: Crude Oil; Esterification; Biodegradable; Electrical Insulation.

Copyright © Hendri, Yanuar Zulardiansyah Arief, Abdul Syukur

This is an open access article under the: <https://creativecommons.org/licenses/by/4.0/>

INTRODUCTION

Transformers that transmit and distribute electricity from the generator to the load (electrical load) are crucial components of the power network. Failure of a transformer poses a threat to both the environment and people. By performing routine maintenance and inspections, disturbances in distribution transformers can be reduced. Unfortunately, both are costly and time-consuming (Bashi, et al., 2006). An image of a 100 kVA power transformer can be found in Figure 1.

In the event that the coils of the transformer become too hot when it is working (at voltage), insulators are one of the most crucial materials utilized as guards and coolers for the transformer. The transformer uses oil as electrical insulation, using up space inside the device. So, by keeping an eye on the oil's condition, the transformer's technical state can be assessed (Jonathan et al., 2014). According to Eberhardt et al. (2010), the majority of

distribution transformers typically employ mineral oil as their primary insulating fluid. Mineral oil costs are somewhat less expensive, but it is difficult to degrade and is not environmentally friendly (Bashi et al., 2006). Additionally, according to the records of the transformer, the isolation system has had the most failures/faults.



Figure 1. Photo of a distribution transformer with a capacity of 100 kVA

Due to its excellent dielectric qualities, low viscosity, and high cooling performance, this mineral oil is frequently employed as a coolant (Bashi et al., 2006). However, because mineral oil is so corrosive, it may have a harmful effect on the environment if there were a significant leak. According to Suwarno et al. (2003), the demand for mineral oil, a non-renewable resource derived from petroleum, is predicted to decline in the upcoming years. Researchers are looking for alternatives to mineral oil in electric power transformers due to recent improvements and considerations of fire hazards.

Palm oil was chosen for this study because Indonesia is one of the largest palm oil producers in the world and there is an abundant supply of palm oil in the market. In general, palm oil is limited to cooking oil, household use, and cosmetic products (Jonathan, et al., 2014). The non-acidic and biodegradable properties of palm oil make it suitable for use as basic insulating oil in electric power transformers (Suwarno, et al., 2003). Therefore, this research to test the possibility of using palm oil-based oil esters as insulating oils and transformer coolers as a substitute for mineral oil is urgently needed.

This study aims to esterify palm oil for electrical insulation, analyze the comparative electrical, physical, and chemical characteristics of palm oil-ester and mineral oil as electrical insulation and investigate the technical performance of using palm oil-ester in electric power transformers.

METHOD

The methods used in this research include field research, literature study, and analysis. Field research includes: taking oil samples, and measuring the breakdown voltage of transformer oil, and the color of transformer oil. One of the important parts of the electric power system is the electric power transformer (power transformer). An electric power transformer is an electric power equipment that functions to transmit power/power from high voltage to low voltage or vice versa (transforming voltage). In the distribution of electric power, the transformer can be said to be the heart of the transmission and distribution system. In this condition, a transformer is expected to operate optimally (if possible continuously without stopping). Given the hard work of a transformer like that, maintenance methods are also required as well as possible. Therefore, it is very important to ensure that the electric power system can function properly without interruptions and problems during operation. This is very necessary to ensure that the electric power system operates stably. During operation, the transformer will generate heat. To provide an efficient and reliable function, the transformer coil must be isolated [6]. Most power transformers, their coils, and cores are immersed in transformer oil called mineral oil (derived from processing petroleum). This oil function as a heat transfer and as an insulating material (has a high breakdown voltage). Figure 2 shows a photo of an electric power transformer in general and its parts.



Figure 2. Electric power transformer and its parts

Today, insulating fluids based on oil are used in practically all distribution transformers in electric power sector systems. Inside the transformer, the insulating oil serves as both a coolant and an insulating dielectric. Because oil quality is crucial to carrying out both roles, transformer oil qualities have been examined technically for decades (Rouse, 1998).

Transformer Insulation Oil

Insulating oil functions in distribution transformers as a coolant and insulator in the presence of a strong electric field. The insulating oil inside the transformer can absorb heat from the iron core and windings, which can subsequently be released to the exterior and the transformer's surface. The heat produced during operation (electrical voltage) causes an increase in temperature, which causes the viscosity of the insulation oil to decrease, aiding in appropriate oil current circulation inside the transformer. Different regions of the oil will be isolated at various electric potentials. Transformer insulating oil, in addition to serving as insulation, is crucial for cooling the transformer by entering and filling the crevices between the coils (Jonathan, et al.

Mineral Oil

According to All About Palm Oil (2011), mineral oil is a blend of carbon and hydrogen compounds such cyclohexane, hexane, naphthenic, paraffin, aromatic, and benzene. Water reacts naturally with the metal carbides in crude oil to produce mineral oil. Electric power transformers have long employed mineral oil as a dielectric insulating fluid. Petroleum-based products, on the other hand, are a finite resource that will eventually exhaust in the next years (All About Palm Oil, 2011).

Palm oil

Oil is produced during the separation of palm kernels from oil palm fruit bunches. The palm kernel is made up of a tough seed called the kernel. The mesocarp, a fruit fiber, is placed on top of the endocarp, a shell that protects the kernel. Palm kernel oil (PKO) and crude palm oil (CPO) are both derived from the mesocarp and palm kernel of the palm tree. An illustration of the oil palm seed's structure is shown in Figure 3.

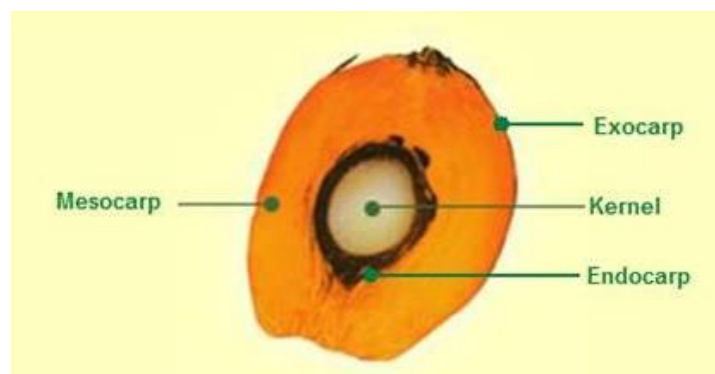

Figure 3. Cross section of the palm fruit

Vegetable seeds must be gathered from trees as the initial stage in creating dielectric/insulating fluids based on vegetable oil. The oil must be treated with specific solvents to eliminate any undesired components once all solids have been removed. The palm oil will be cleaned using a clay filtering procedure called bleaching. The following step is the deodorization procedure, which uses steam to remove odor-producing volatile (unstable) components. With conductivities ranging from 5 to 50 pS/m, the electrical purity of refined bleached deodorized palm oil (RBDPO) varies from negligible to impure. It is preferred that the insulating oil used in electric power transformers have a conductivity value of 1 pS/m or less (Abdullahi, et al., 2004).

Biodegradable Oil

The excellent biodegradable oil can serve as a suitable replacement for current oils (mineral oil). Because biodegradable oil may naturally disintegrate, it can reduce the environmental impact of spills and other situations involving oil. As a result, the environment and living things won't be impacted by dangerous substances. Because they have greater fire and flash points than the majority of mineral oil-based liquids, biodegradable oils are also safer. Biodegradable oil also has a low toxicity impact on living things and people. Because it is food grade, biodegradable oil is very simple to handle. Additionally, if biodegradable oil takes the place of mineral oil, the nation's reliance on petroleum supplies will be reduced and participation in local agricultural output will naturally rise (Oommen et al., 1997).

Oils that can be made from *Moringa Oliefera* seeds, sunflower, soybean, palm, olive, and coconut seeds are also ideal for use as dielectric insulating liquids. Sunflower oil has been put to the test for use in transformers in a number of nations, and the results revealed that it has superior qualities to mineral oil, synthetic ester, and silicone oil. A sample image of mineral oil and palm oil, specifically palm oil olein, is shown in Figure 4.



(a) Mineral oil (b) olein-sawn oil
Figure 4. Oil samples for electrical insulation

RESULT

The research method includes 4 (stages), namely preparation of palm oil-ester samples, testing the electrical, physical, and chemical characteristics of palm oil-ester samples, testing the effects of accelerated aging of palm oil-ester samples, testing palm oil-ester on electric power transformers and performance overall transformer compared to conventional electric power transformers (using mineral oil). A more detailed description of each stage of the research method is explained as follows:

Palm Oil-Ester Sample Preparation

First, the esterification of palm oil will be carried out in this research. Ester samples with several different palm oil essence-based formulations will be developed. The purpose of esterification of palm oil is to make the oil more chemically stable, especially when exposed to oxygen. Mineral oil samples will also be prepared in this study which will be used as a comparison of electrical, physical, and chemical characteristics. Figure 5 shows the principle of the chemical process of the esterification of vegetable oils.

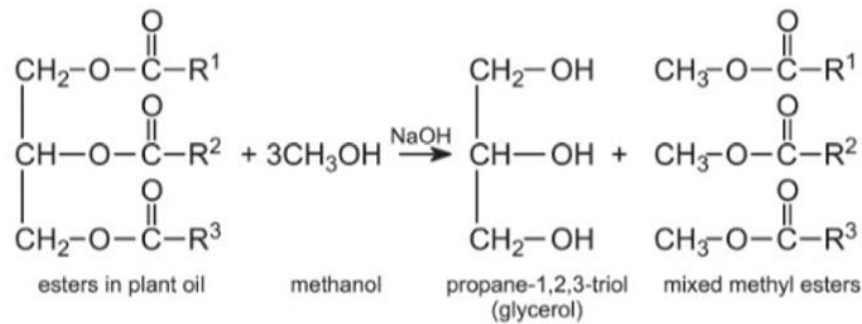

Figure 5. Chemical structure of the esterification process of vegetable oils

Testing of Electrical, Physical, and Chemical Characteristics of Palm Oil-Ester Samples

From several formulations of palm oil-ester samples obtained from the esterification process, electrical, physical, and chemical characteristic tests will then be carried out following the standards set for insulating oil used in electric power transformers. In full, all types of tests on palm oil-ester samples are summarized in Table 1.

Table 1. Types of Tests to be Performed in This Research

Types of Palm Oil-Ester Sample Testing		
Electrical Characteristics (Test Standard)	Physical Characteristics (Test Standard)	Chemical Characteristics (Test Standard)
Breakdown Voltage (IEC 60156)	Viskositas (ISO 3104)	acidity (IEC 62021)
Partial Discharge (IEC 60270)	Pour Point (ISO 3016)	Contains 2-Furfural (IEC 61198)
Dissipation Factor (IEC 60250)	Water Content (IEC 60814)	Oxidation stability (IEC 61125 C)
Dielectric Type Resistance (IEC 60250)	Density (ISO 12185)	Total sulfur (BS20000-373)
	Flash point (ISO2719)	Sulfur Corrosion (DIN 51353/IEC 62535)
	interfacial tension (ISO 6295)	Sludge (%)

Figure 6 shows a circuit for testing the breakdown voltage of palm oil-ester samples carried out in the laboratory. Figure 7 shows a series of partial discharge (PD) tests on palm oil-ester samples. The PD signal is detected using an integrated RC circuit and the data is stored in the oscilloscope. The needle-plane electrode arrangement is used in this PD test. The needle electrode is made of tungsten carbide with a radius of 0.01 mm. To prevent the breakdown of the oil sample, an acrylic barrier with a thickness of 5mm is placed between the needle electrode and the plane electrode at a distance of 2. mm from the tip of the needle electrode as shown in Figure 9. The PD signal is obtained at varying voltages from 10 ~ 30 kVrms by every 1 kVrms increment with an interval of 2 minutes.



(a) High voltage test circuit (b) The test cell contains the oil to be tested
 Figure 6. Circuit for testing the breakdown voltage of the palm oil-ester sample

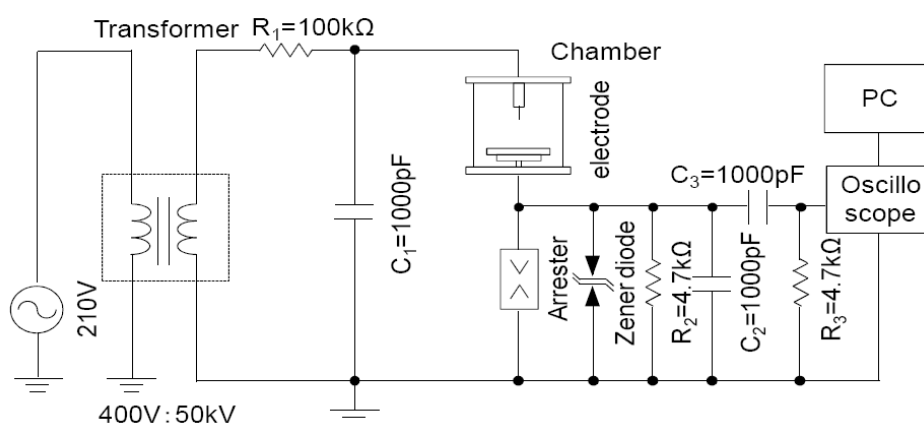

Figure 7. Series of partial discount tests on palm oil-ester samples

PD Test Chamber

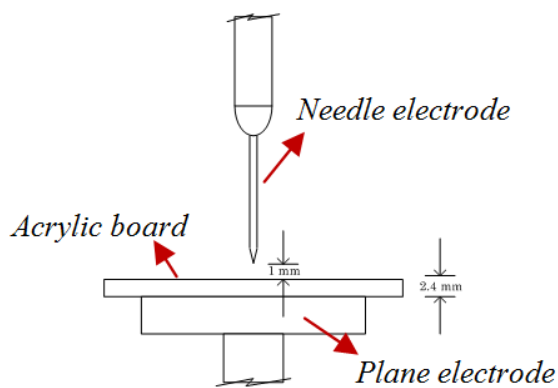

Figure 8: Electrode arrangement for partial discount testing on palm oil-ester samples

Testing Effects of Accelerated Heat Aging of Palm Oil-Ester Samples

To simulate real conditions in the field, testing the effect of accelerated thermal aging of palm oil-ester samples was carried out. A heating oven with adjustable temperature was used in this test. The temperature was set at 130oC with a heating time of 50, 100, 200, 500, and 1000 hours. Then, for each duration of aging, the sample is tested for its electrical, physical, and chemical characteristics. Figure 9 shows an illustration of the accelerated aging effect test for palm oil-ester.

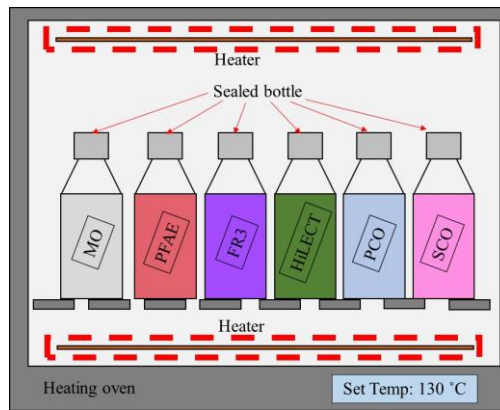

Figure 9. Illustration of testing the effect of accelerated aging on palm oil-ester samples in the oven

DISCUSSION

From the three stages of the test above, the best palm oil-ester sample formulation will be obtained based on its electrical, physical, and chemical characteristics according to established standards for use as insulating oil in electric power transformers. This best formulation will be filled with a real electric power transformer (with a power capacity of 100 kVA) and then tested for its technical performance (efficiency and losses) during operation. The palm oil-ester sample in the transformer will also be tested for its electrical, physical, and chemical characteristics after being used for a certain time and the results will be compared with applicable standards whether it is suitable for use as insulating oil in transformers. Figure 10 shows a model of a complete series of technical performance testing of palm oil-ester used in electric power transformers.

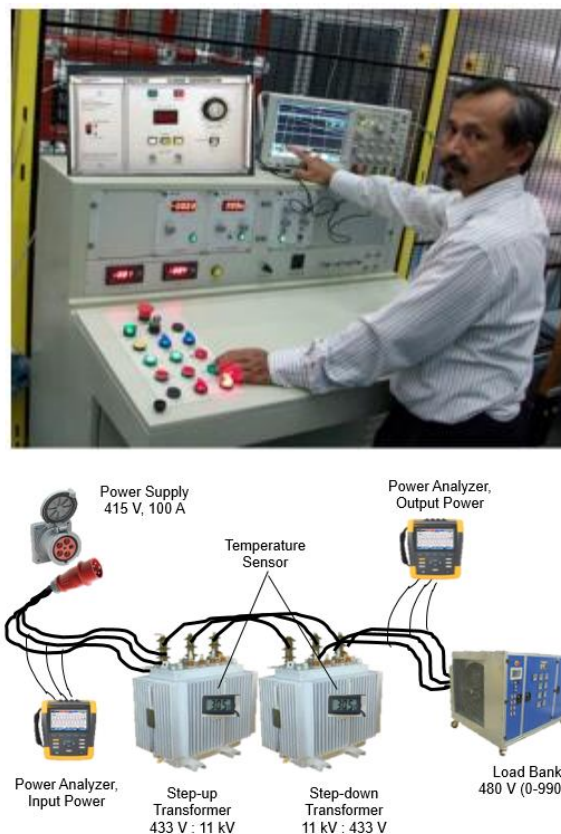

Figure 10: Circuit model for testing the performance of electric power transformers using palm oil-ester

CONCLUSION

From the research conducted, it was obtained that insulating oil for electric power transformers is based on palm oil. Palm oil has the advantage of being an environmentally friendly, biodegradable, and renewable oil compared to the transformer oil used today which is based on petroleum. With the realization of transformer oil based on palm oil, it is hoped that it can provide great economic opportunities for Indonesia as one of the largest palm oil producers in the world and can also provide added value and increase the competitiveness of the palm oil industry in the future.

Palm oil has a high permittivity compared to mineral oil with an increase in temperature, so a high permittivity can reduce the electric field in the oil when applied to a plated dielectric with a pressboard inside a power transformer. The lower the electric field in the oil, the higher the breakdown voltage of the oil.

This is in line with one of the main principles set by the government for the Palm Oil Plantation Fund Management Agency (BPDP), namely to encourage palm oil-based renewable energy so that it is beneficial to reduce dependence on imported fossil fuels or fuel oil (BBM).

REFERENCES

- Bashi, S. M., Abdullahi, U. U., Yunus, R., & Nordin, A. "Use of Natural Vegetable Oils as Alternative Dielectric Transformer Coolants", *The Institution of Engineers, Malaysia*, 67(2), 4–9, 2006.
- Jonathan O. Obande, and Dr. Jonathan U. Agber. "Palm Oil as an Alternative Dielectric Transformer Coolant," *International Journal of Research in Engineering and Science (IJRES)*, June 2014.
- Eberhardt, R., Muhr, H. M., Lick, W., Wieser, B., Schwarz, R., & Pukel, G. "Partial discharge behavior of an alternative insulating liquid compared to mineral oil." *Proceedings of the 2010 IEEE International Power Modulator and High Voltage Conference*, 426–429, 2010.
- Suwarno, S., Sitingjak, F., Suhariadi, I., & Imsak, L. "Study on the characteristics of palm oil and its derivatives as liquid insulating materials". *Proceedings of the 7th International Conference on Properties and Applications of Dielectric Materials*, 2, 495–498. 2003.
- Rouse, T. O. Mineral insulating oil in transformers. *IEEE Electrical Insulation Magazine*, 14(3), 6–16, 1998.
- All about palm oil: <http://maturepalmoil.blogspot.my/2011/03/mophologi-kelapa-sawit.html>
- Azis, N., Jasni, J., Ab Kadir, M. Z. A., & Mohtar, M. N. Suitability of palm based oil as dielectric insulating fluid in transformers. *Journal of Electrical Engineering and Technology*, 9(2), 662–669, 2014.
- Abdullahi, U. U., Bashi, S. M., Yunus, R., Mohibullah, & Nurdin, H. A. "The potentials of palm oil as a dielectric fluid." *National Power and Energy Conference, PECon 2004 - Proceedings*, 224–228, 2004.
- Oommen, T. V., Claiborne, C. C., & Mullen, J. T. "Biodegradable electrical insulation fluids." *Proceedings: Electrical Insulation Conference and Electrical Manufacturing and Coil Winding Conference*, 465–468, 1997.
- M. Hikita, J. Tokiyoshi, M. Tsuchie, M. Kozako, "Partial discharge properties of ester oils having different molecular structures", IEEE 2012.
- A. Susilo, J. Muslim, Y. Z. Arief, M. Hikita, "Comparative study of partial discharge characteristics and dissolved gas analysis on palm-based oil as insulating material", The 2nd IEEE Conf. on Power Engineering and Renewable Energy, 2014