

Flight-critical load failure analysis in HVDC More-Electric Aircraft applications

Kieran Millar

*Institute of Energy and Environment
University of Strathclyde
Glasgow, UK
kieran.millar@strath.ac.uk*

Kenny Fong

*Institute of Energy and Environment
University of Strathclyde
Glasgow, UK
kenny.fong@strath.ac.uk*

Patrick J. Norman

*Institute of Energy and Environment
University of Strathclyde
Glasgow, UK
patrick.norman@strath.ac.uk*

Graeme M. Burt

*Institute of Energy and Environment
University of Strathclyde
Glasgow, UK
graeme.burt@strath.ac.uk*

Abstract—The electrification of aircraft is a key and proven means of realising decarbonisation. A key pillar of this, the More-Electric Aircraft (MEA), has been shown to be a viable alternative to conventional aircraft where traditionally pneumatic and hydraulic systems are replaced with electrical equivalent systems such that efficiency gains, noise, carbon emission and mass reductions are achieved. With electrical systems performing new flight-critical roles on-board MEA, and the Power Electronic Converter (PEC) being a core technology in these systems, there has been increased interest in recent years in better characterising and improving the reliability of PECs. Using Fault-Tree Analysis (FTA) and Reliability Block Diagram (RBD) methods, this paper presents a study of the contribution of the PEC failure rates to the reliability of flight-critical loads in a concept High Voltage Direct Current (HVDC) aircraft application. It is shown that whilst the failure rate of PECs will typically shape the overall failure rate of electrical systems and subsystems, the installed redundancy in aircraft Electrical Power System (EPS) mitigates the risk of unacceptably high rates of failure in flight critical loads, even if the aircraft is dispatched in a non-full-up configuration. Moreover, the paper illustrates how the greatest gains in these load systems' reliability can be realised through improvements in the reliability of the PEC interfaces to these load subsystems, where there is naturally less system redundancy.

Index Terms—More-Electric Aircraft, Power Electronic Converter, Reliability, Electrical Power System

I. INTRODUCTION

The electrification of aircraft through the implementation of the More-Electric Aircraft (MEA) ideology has led to improvements in efficiency, noise and emissions, through the utilisation of electrical technologies to perform new roles within the aircraft system. In particular, MEA applications see the progressive removal of pneumatic, hydraulic and mechanical systems, and their subsequent replacement with electrical equivalents [1], [2]. This progression offers a solution whereby mass reductions are possible, whilst also offering additional opportunities for electrical diagnostics for fault identification and on-line monitoring, enabling additional potential cost reductions through enhanced reactive

and predictive maintenance procedures [3]. With the introduction of starter-generator systems, higher voltage power distribution systems and motor-driven loads (including actuators and pumps), the Power Electronic Converter (PEC) is now one of the key underpinning technologies in modern MEA. Accordingly, its reliability shapes the reliability of many on-board MEA systems.

In the literature, roadmaps for reliable PEC topologies and the reliability-oriented design of PEC for aircraft applications are presented [4], [5]. In addition, authors in [6] present an initial study examining the sensitivity of a hybrid AC-DC Boeing 787-type architecture to reliability-enhancing features within PEC designs.

Accordingly, this paper presents a complementary study of the reliability of an equivalent High Voltage Direct Current (HVDC) aircraft Electrical Power System (EPS) architecture, supplying flight-critical electrical loads, and considering the same range of PEC failure rates as [6]. The generated results will enable a direct comparison with the previous study in order to illustrate how the change of primary power distribution method impacts on the failure rates of flight-critical loads. This study will also consider both full-up and off-nominal EPS operating configurations to understand the impact of in-flight failures on the system sensitivity to PEC reliability. The paper concludes with reflections on required further study in this area.

II. HVDC ARCHITECTURE OVERVIEW

The HVDC EPS, shown in Fig. 1 was developed by incorporating key features from conventional hybrid AC/DC MEA EPS architectures from the literature (such as starter-generators for electrical main-engine starting) and combining these with DC-MEA-specific features where appropriate [7], [8]. A reference AC/DC MEA EPS is presented in Fig. 2, where AC is used as the primary power distribution voltage whilst featuring a four-generator system, with four associated distribution channels. In the proposed HVDC architecture,

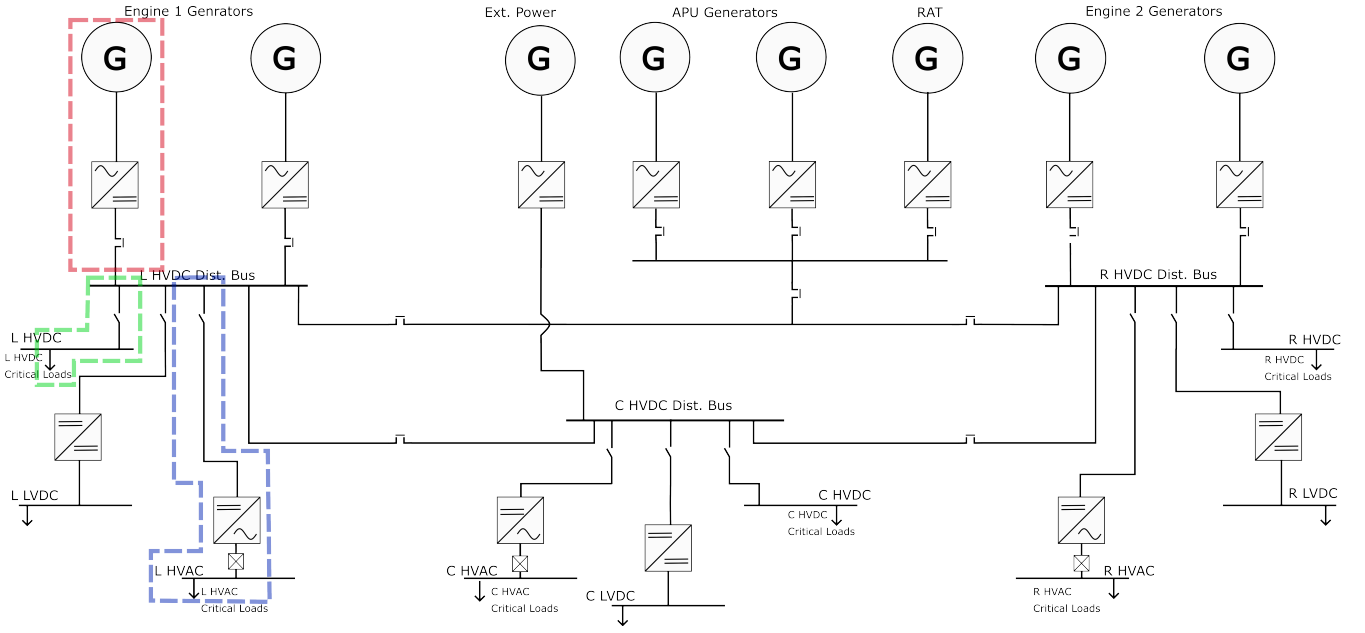

Fig. 1: HVDC MEA EPS architecture, with section G1 shown in red, L1_{HVDC} in green and L1_{HVAC} shown in blue.

a four generator system is once again used (with power levels also assumed to be consistent with the High Voltage Alternating Current (HVAC) architecture). However, in this design generators are paralleled onto a common busbar on a per-engine basis (exploiting the ease of paralleling possible with DC). These then supply three main load busbars per voltage level, with PEC utilised for the conversion to 28 V_{dc} and 230 V_{ac} load busbars, respectively, whilst HVDC loads are fed from a dedicated load busbar that connects with the main distribution bus. This architecture is also equipped with an Auxiliary Power Unit (APU), for electrically starting the main engines and for providing additional electrical power during flight in the case of a main generator failure, with a Ram Air Turbine (RAT) also available for use in extenuating circumstances.

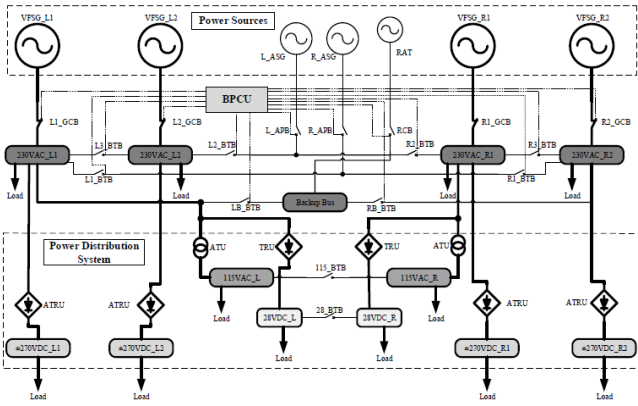

Fig. 2: A reference AC/DC, Boeing 787-type architecture [9]

III. CALCULATED PROBABILITY OF FAILURE OF FLIGHT-CRITICAL LOADS

By employing the RBD method for the reliability analysis of the EPS, an expression for the reliability of the flight-critical loads (for example, the Environmental Control System (ECS) and flight surface actuation systems) can be determined based on their supply from either HVDC or HVAC buses. An example RBD is shown in Fig. 3, this is consistent with the FTA approach that will be discussed in subsequent sections. Note, that constituent components of network subsections G_x and L_x are illustrated in Fig. 1. In the case of FTA, the top event failure is defined as the probability of failure of the complete loss of supply to the flight-critical loads. In keeping with the RBD approach, this can be mathematically defined using the base equations for the determination of series reliability, $R_{series}(t)$, as

$$R_{series}(t) = e^{-\lambda t}, \quad (1)$$

where λ is the summation of failure rates in the series channel, and for the purpose of this analysis, t is defined as a single flight-hour. In addition, parallel reliability, $R_{parallel}(t)$, is defined as

$$R_{parallel}(t) = 1 - ((1 - e^{-\lambda_1 t})(1 - e^{-\lambda_2 t}) \dots (1 - e^{-\lambda_n t})), \quad (2)$$

where λ_n is defined as the summation of failure rates in each parallel channel.

Furthermore, it is assumed that each flight critical load is duplicated three times within the EPS, offering three layers of redundancy at the load level via the left, right and centre load busbars. In keeping with the analysis conducted of the

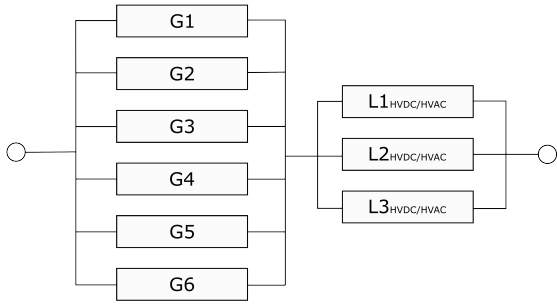

Fig. 3: Reliability Block Diagram

baseline AC/DC MEA EPS in [6], the rate of complete failure of the generic flight critical loads was evaluated (including failures of supply to these loads) using four separate failure rates for PEC subsystems within the EPS. These consisted of:

- a baseline PEC failure rate extracted from NPRD-16 database [10]
- a physics-of-failure modelling-derived failure rate for a PEC topology with controlled circulating current injection (offering a 68.25% reliability improvement [11]),
- a failure rate representative of the use of integrated power modules (with a stated ten-fold improvement against the baseline failure rate [12]).
- and an idealised scenario with a PEC failure rate of 0; this is to establish a best-case the system asymptote for reference purposes.

The complete failure rate data for components used within this analysis is shown in Table I, where the PEC presented is that of the baseline.

Table I: Failure rate data for components used within the system [10], [13], [14]

Component	Failure Rate (hour ⁻¹)
Cable	8.09×10^{-7}
Busbar	3.96×10^{-9}
Motor	2.31×10^{-6}
Circuit Breaker	5.28×10^{-6}
Solid State Power Controller	5.28×10^{-7}
Generator	1.41×10^{-5}
Power Converter	4.54×10^{-5}
Switch	5.28×10^{-6}
Contactors	5.28×10^{-7}

As stipulated in CS-25 [15] and 14 CFR Part 25 [16], extremely improbable failure conditions should be considered so unlikely that failures of this nature must have a probability of occurrence of less than 1×10^{-9} per flight hour. This provides a benchmark for performance for the

Table II: Probability of failure per flight hour, for the complete loss of generic flight-critical electrical loads within a HVDC MEA EPS

PEC Reliability Multiplier	HVAC Supplied Loads	HVDC Supplied Loads
1	1.328×10^{-12}	1.475×10^{-13}
0.5952	3.911×10^{-13}	4.086×10^{-14}
0.1	2.232×10^{-14}	1.665×10^{-15}
0	6.883×10^{-15}	4.441×10^{-16}

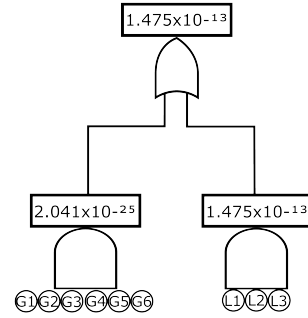

Fig. 4: FTA for the complete loss of all generic HVDC flight-critical loads in full-up system configuration.

considered generic flight-critical loads. In Table II, the probability of complete failure of the generic flight-critical loads, as supplied by either the HVAC or HVDC buses, is presented. The calculated probabilities all provide a good degree of margin over the minimum required 10^{-9} probability requirement. When this is compared with the analysis in [6], it can be seen that the HVAC EPS offers superior probability of failure for selected flight-critical electrical loads. This can be attributed to the additional layer of load redundancy in HVAC architecture.

IV. FAULT-TREE ANALYSIS IN FULL-UP SYSTEM CONFIGURATION

From a reliability perspective, a system's construction allows for the creation of an RBD. From this RBD, an equivalent fault tree can be constructed, whereby systems connected in series take the form of an AND gate, with parallel systems an OR [17]. The individual component failure rate is shown in Table I, with the resultant FTA shown in Fig. 4 for the complete loss of supply to all three generic HVDC connected loads within the EPS in Fig. 1.

As shown in Fig. 4, it is clear that the system-level failure characteristics are driven primarily by the load-side of the EPS, with the contribution from the generator-side being negligible in this configuration and for this particular top event. This behaviour is also replicated in the analysis of generic HVAC loads in this configuration. The probabilities of failure per flight hour, for the complete loss of all generic

flight-critical loads are already shown earlier in Table II. When observing the factor of improvement between the baseline and the ten-fold improvement in PEC failure rate, the top event failure rate is reduced by a factor of 88.6 and 59.5 for HVDC and HVAC connected-loads respectively. Interestingly, it can be deduced from this, that despite the HVDC connected-loads exhibiting one less conversion stage than that of HVAC connected-loads, and there being a noticeably reduced probability of failure, the HVDC portion of the EPS displays a higher degree of sensitivity to changes in PEC failure rate. In addition, it can be seen that the further enhancement of the PEC failure rate to the ideal case only yields an improvement in the top event failure rate of a factor of 3.75 and 3.24 for HVDC and HVAC connected-loads, respectively. This suggests that beyond a ten-fold improvement of PEC failure rate, other EPS components more significantly shape the top event failure rate.

V. OFF-NOMINAL FAILURE ANALYSIS

In this section, case studies of the load-channel and generator-channel off-nominal operating scenarios and the impact of the PEC failure rates on the resulting system reliability will be presented. Each case will be evaluated with baseline PEC failure rate, 68.25% improvement, ten-fold improvement and infinite PEC lifetime, respectively. In all the cases studied, the top event associated with each of the FTAs is the complete loss of supply to all associated flight-critical loads of an HVDC or HVAC group.

A. Off-Nominal Conditions on the Load-Channel

In this study, the effects of losing a load channel for both HVAC and HVDC loads were considered in isolation, with the system evaluated at each multiple of PEC failure rate. Figs. 5 and 6 present the fault trees for the loss of supply to all HVDC/HVAC loads, respectively, following the loss of one of the load channels. with Table III, showing the calculated top event probability of failure per flight hour for each of the considered PEC failure rate multipliers (where the loss of a single load-channel, $L3_{HVDC/HVAC}$ is assumed).

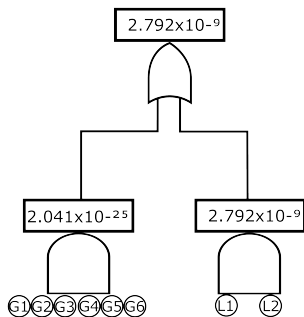

Fig. 5: FTA for the complete loss of supply to all generic flight-critical HVDC loads with 1 out of 3 load channels failed.

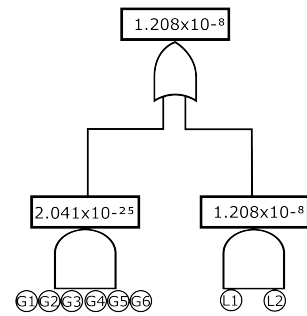

Fig. 6: FTA for the complete loss of supply to all generic flight-critical HVAC loads with 1 out of 3 load channels failed.

Table III: Probability of failure per flight hour for the complete loss of all generic flight-critical electrical loads within a HVDC EPS in off-nominal load failure cases

PEC Reliability Multiplier	HVAC Supplied Loads	HVDC Supplied Loads
1	1.208×10^{-8}	2.792×10^{-9}
0.5952	5.348×10^{-9}	1.187×10^{-9}
0.1	7.920×10^{-10}	1.428×10^{-10}
0	3.631×10^{-10}	5.490×10^{-11}

From the presented results, it can be seen that in all cases, the loss of a load-channel can have a particularly detrimental effect on the considered top event rate of failure. Whilst each reduction in failure rate of the PEC does ultimately result in a reduced failure rate for both HVDC and HVAC load top events, the relative improvement is considerably less than for the same change in the full-up configuration. For example, considering the HVAC loads, the reduction factor in the calculated top event failure rate in this degraded EPS configuration employing the baseline and ten-fold improvement PEC failure rates is 15.26 (it was previously a reduction factor of 59.5 for the full up configuration).

Interestingly, the further enhancement of the PEC failure rate to the ideal case only yields an improvement factor in the top event failure rate of 2.18 (compared with the reduction factor of 3.24 for the full up configuration).

B. Off-Nominal Conditions on the Generator-Channel

In this study, the effects of the loss of a generator-channel on the rate of failure for the complete loss of supply to all generic HVDC/HVAC flight critical loads is presented. Figs. 7 and 8 present the fault trees for the loss of supply to all HVDC/HVAC loads respectively, following the loss of one of the generator channels, with Table IV, showing the calculated top event probability of failure per flight hour, at each of the PEC failure rate multipliers when considering the loss of a single generator-channel, G1.

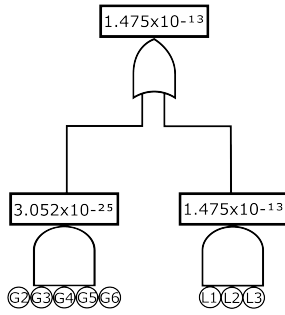

Fig. 7: FTA for the complete loss of all generic flight-critical HVDC loads with 1 out of 4 generators-channels failed.

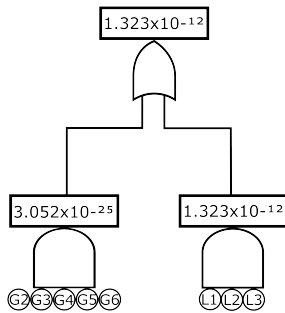

Fig. 8: FTA for the complete loss of all generic flight-critical HVAC loads with 1 out of 4 generators-channels failed.

Table IV: Probability of failure per flight hour for the complete loss of all generic flight-critical electrical loads within a HVDC EPS in off-nominal generator-channel failure cases

PEC Reliability Multiplier	HVAC Supplied Loads	HVDC Supplied Loads
1	1.328×10^{-12}	1.475×10^{-13}
0.5952	3.911×10^{-13}	4.086×10^{-14}
0.1	2.232×10^{-14}	1.665×10^{-15}
0	6.883×10^{-15}	4.441×10^{-16}

From the presented results it can be seen that the impact of the loss of a single generator channel on the top events' probability of failure is minimal. In both cases, the contribution from the load channels still dominates the make-up of the top event probability of failure per hour. This finding is echoed by the very close alignment of the top event probability of failure per flight hour when compared with the full up configuration (at least to the 3 decimal places considered in this paper).

It is worth noting that whilst the loss of a generator

does not impact on the top event probability of failure per flight hour, it does affect the operational ability of the aircraft. In the event of a single failed generator, dispatch is still typically permitted, however restrictions mandating a reduction in Extended Twin-engine Operation (ETOPS) range from 330 minutes to 180 minutes, whilst limiting maximum flight duration to 6 hours would be expected to be applied [18]. In addition, there would likely be restrictions placed on flight operability, where the aircraft operator would be required to ensure that the repair of the faulted generator is performed within 3 flight-days.

VI. CONCLUSIONS

This paper has shown that whilst the typical failure rates of PEC subsystems are comparatively high compared to many other EPS technologies, and that these significantly influence the overall failure rates of flight-critical electrical systems, the redundancy typically implemented within an aircraft EPS mitigates this risk to acceptable levels (even in an HVDC architecture with its slightly reduced redundancy compared to HVAC systems). Furthermore, with the particularly extensive redundancy implemented in the connection of main and auxiliary generators, it has been shown that the failure rates of components in these generation channels (including the PEC) has a negligible influence on the failure rate of flight critical electrical loads. As such, the greatest gains in flight-critical load system reliability will be realised through improvements in the reliability or redundancy of the PEC interfaces to these flight-critical electrical loads. Accordingly, the next step of the authors' research in this area is to explore the trades of weight penalties and reliability benefits afforded by additional-redundant or more reliable PEC technologies for the load interfaces and to make recommendations on best design practice.

ACKNOWLEDGMENT

This work was supported by the Rolls-Royce University Technology Centre program at the University of Strathclyde.

REFERENCES

- [1] B. Sarlioglu and C. T. Morris, "More electric aircraft: Review, challenges, and opportunities for commercial transport aircraft," *IEEE Transactions on Transportation Electrification*, vol. 1, no. 1, pp. 54–64, 2015.
- [2] V. Madonna, P. Giangrande, and M. Galea, "Electrical power generation in aircraft: Review, challenges, and opportunities," *IEEE Transactions on Transportation Electrification*, vol. 4, no. 3, pp. 646–659, 2018.
- [3] A. Starr, "Aircraft health monitoring - towards more electric aircraft," *Impact*, vol. 2018, no. 5, pp. 48–50, 2018.
- [4] A. J. Wileman, S. Aslam, and S. Perinpanayagam, "A road map for reliable power electronics for more electric aircraft," *Progress in Aerospace Sciences*, vol. 127, p. 100739, 2021.
- [5] R. Burgos, G. Chen, F. Wang, D. Boroyevich, W. G. Odendaal, and J. D. Van Wyk, "Reliability-oriented design of three-phase power converters for aircraft applications," *IEEE Transactions on Aerospace and Electronic Systems*, vol. 48, no. 2, pp. 1249–1263, 2012.
- [6] K. Millar, K. Fong, R. Peña Alzola, P. J. Norman, and G. M. Burt, "System wide reliability impact of power converters in more-electric aircraft applications," in *SAE Technical Paper 2023-01-0991*, 2023, pp. 1–8.

- [7] Q. Zhang, M. Szykiel, P. J. Norman, and G. M. Burt, "Towards dual and three-channel electrical architecture design for more-electric engines," in *SAE Technical Paper 2018-01-1935*, 2018, pp. 1–11.
- [8] Boeing, "787 no-bleed systems," 2007.
- [9] K. Xu, N. Xie, C. Wang, and X. Shi, "Modeling and simulation of variable speed variable frequency electrical power system in more electric aircraft," *The Open Electrical and Electronic Engineering Journal*, vol. 13, pp. 87–98, 2017.
- [10] Quanterion Solutions Incorporated, "Nonelectronic parts reliability data publication (nprd-2016)," Quanterion Solutions Incorporated, Utica, New York, United States, Tech. Rep., 2016.
- [11] N. B. Kadandani, M. Dahidah, S. Ethni, and M. Muhammad, "Lifetime and reliability improvements in modular multilevel converters using controlled circulating current," *Journal of Power Electronics*, vol. 21, no. 10, pp. 1611–1620, 2021.
- [12] B. Abdi, A. H. Ranjbar, G. B. Gharehpetian, and J. Milimonfared, "Reliability considerations for parallel performance of semiconductor switches in high-power switching power supplies," *IEEE Transactions on Industrial Electronics*, vol. 56, no. 6, pp. 2133–2139, 2009.
- [13] Department of Defense, "Reliability prediction of electronic equipment (mil-hdbk-217f)," Department of Defense, Virginia, United States, Tech. Rep. F, dec 1991.
- [14] M. Glass, "Performance comparison: Solid state power controllers vs. electromechanical switching," Data Device Corporation, Bohemia, New York, Tech. Rep., 07 2010.
- [15] EASA, "Certification specifications and acceptable means of compliance for large aeroplanes (cs-25)," EASA, Cologne, Germany, Tech. Rep. 27, nov 2021.
- [16] Federal Aviation Administration, "14 cfr 25 - air worthiness standards: Transport category airplanes," Federal Aviation Administration, Washington, D.C., United States, Tech. Rep., 2014.
- [17] D. J. Smith, *Reliability, Maintainability and Risk: Practical Methods for Engineers*. Butterworth-Heinemann, 2011.
- [18] Hutton, Rick and Flight Operations Evaluation Board, "Master minimum equipment list (mmel) - boeing 787 - all models," Federal Aviation Administration, Washington, D.C., United States, Tech. Rep. 18, 2023.