



Publication Year	2017
Acceptance in OA @INAF	2023-02-21T15:41:49Z
Title	B23 Cartridge Prototype Manufacturing and Integration Report
Authors	VILLA, Fabrizio; CAVALIERE, Francesco; PEZZOTTA, Federico; VIGANO', Daniele; CUTTAIA, FRANCESCO; et al.
Handle	http://hdl.handle.net/20.500.12386/33718
Number	iAIMA-TEC-TRP-IAB-010



Science and Technology in Italy
For the upgraded ALMA Observatory
- TECHNOLOGY DEVELOPMENT -

B23 Cartridge Prototype Manufacturing and Integration Report

Document code: iALMA-TEC-TRP-IAB-010

Version: B

Status: RELEASED

Date: 15/05/2017

Prepared by		
Name	Organization	Date
Fabrizio Villa	INAF/ IASF-Bologna	15/05/2017
Francesco Cavaliere	UNIMI	
Federico Pezzotta	UNIMI	
Daniele Viganò	UNIMI	
F. Cuttaia	INAF/IASF-Bologna	
S. Ricciardi	INAF/IASF-Bologna	
A. De Rosa	INAF/IASF-Bologna	
P. Yagoubov	ESO	
S. Mariotti	INAF/IRA	
R. Nesti	INAF/OAA	
L. Terenzi	eCampus INAF/IASF-Bologna	
Approved by		
Name	Organization	Date
Fabrizio Villa	INAF/IASF-Bologna	15/05/2017





1 Change Record

Version	Date	Affected sections	Reason
A	09/02/2017	All	Final Review
B	15/05/2017	Section 9	RID #8 AGO
B	15/05/2017	p. 27, section	RID #9 AGO

2 Documents

2.1 Applicable documents

[AD1]	ESO/INAF Contract, Collaboration Agreement No. 64776/15/69626/HNE	14/03/2016
[AD2]	Statement of Work - Development Plan Study for ALMA Band 2+3 Prototype Components, FEND-40.02.02.00-0023-B-SOW	22/02/2016

2.2 Reference documents

[RD1]	iALMA-TEC-TRP-IAB-005-A	Description of Waveguides to be produced	21/11/2016
[RD2]	iALMA-TEC-TRP-IAB-001-A	INAF/JPL LNAs: VNA WARM TEST. As Run Procedure and Results	14/01/2016
[RD3]	iALMA-TEC-TRP-OAA-004-A	EM test of ALMA B23 Waveguides	14/12/2016
[RD4]	iALMA-TEC-TRP-IAB-006-A	NAOJ Cryofacility Dry Run Report	10/01/2017
[RD5]	iALMA-TEC-PRO-IAB-001-A	B23 Cartridge Assembly procedure	08/01/2017
[RD6]	iALMA-TEC-TRP-IAB-009-A	IASF-BO copper strap thermal conductance test report	25/01/2017
[RD7]	iALMA-TEC-TRP-OAA-005-A	Passive Components FINAL Report	07/04/2017
[RD8]	iALMA-TEC-TRP-IAB-008-A	Final Report	07/04/2017
[RD9]	iALMA-TEC-PRO-IAB-001-A	B23 Cartridge Assembly procedure	08/01/2017

3 Acronyms

INAF	Istituto Nazionale di Astrofisica
IASF	Istituto di Astrofisica Spaziale e Fisica Cosmica
OAA	Osservatorio Astrofisico di Arcetri
OMT	Ortho Mode Transducer
FH	Feed Horn
LNA	Low Noise Amplifiers
LNF	Low Noise Factory
UMAN	University of Manchester
UNIMI-WS	Workshop at the Physics Dep. of University of Milano
INAF/JPL	Low Noise Amplifiers developed by JPL and available at INAF



4 Table of content

1	Change Record.....	1
2	Documents.....	2
2.1	Applicable documents	2
2.2	Reference documents	2
3	Acronyms.....	2
4	Table of content.....	3
5	Introduction and Scope.....	4
6	Product tree.....	6
7	Bill of Materials.....	7
8	Waveguide Manufacturing.....	10
8.1	Curved Copper sections	10
8.2	WR10 - 90 degrees Twists	11
8.3	WR10-WR15 Transformers	11
8.4	WR15 and WR10 Stainless steel Waveguides	11
8.5	Straight Copper Sections	12
9	Cartridge Body.....	13
10	Cold Stage	14
10.1.1	15 K receiver support	15
10.1.2	Heatsink, Covers, and fixture	18
10.1.3	Horn brackets and adapters	19
10.1.4	Amplifiers heatsink and thermal braid	20
11	Warm Stage	22
12	Passive Components	23
13	Active Components	24
14	Harness	25
15	Hardware	26
16	ALMA test Cryostat modifications	27
17	Integration	29
17.1	Pre-integration.....	29
17.2	Integration of band 2+3.....	31



5 Introduction and Scope

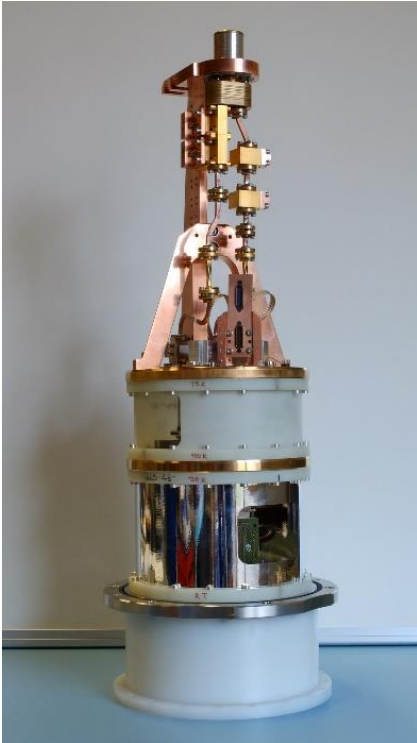

This document reports on the manufacturing and assembly of the B23 Prototype cartridge to perform cryogenic noise tests @ INAF/IASF-Bologna.

The activity started on 20 of September 2016 and ended on 12 December 2016.

The manufacturing has based on the drawings provided by Chalmers University, GARD group. Manufacturing drawings are reported in Annex A. The cartridge structure and waveguide path were designed to permit to mount different configurations depending on passive components and amplifiers.

Mainly, there are 4 variants that depends on the specific passive components (FH and OMT) to be mounted. Since both INAF/OAA and UdC developed passive components for band 2+3 coverage (67-116 GHz) the basic idea is to use this resource to identify the best combination of components in terms of overall performances.

For each 'variant', there are different configurations that depend on the amplifiers chain configuration that could be mounted. According to the ALMA polarization channel designation, the baseline configuration foresees the following configuration:

- Pol-0: this chain mounts 2 or 3 LNAs (depending on the availability) developed by UMAN.
- Pol-1: this chain mounts 2 INAF/JPL amplifiers [RD2]

	Variant 1	Variant 2	Variant 3	Variant 4
Feed Horn	UdC	INAF	INAF	UdC
OMT	UdC	UdC	INAF	INAF

Originally the waveguide routing design foreseen to accept the two setup of the Pol-0 chain and the setup of the Pol-1.

In October 2016 we had the chance to mount also the Low Noise Factory (LNF) cryogenic amplifiers. We changed the waveguides configuration on the fly to accommodate the new amplifiers. The design of the new routing is explained on the technical note [RD1], allowing the integration of the LNF amplifiers together with the INAF/JPL ones.

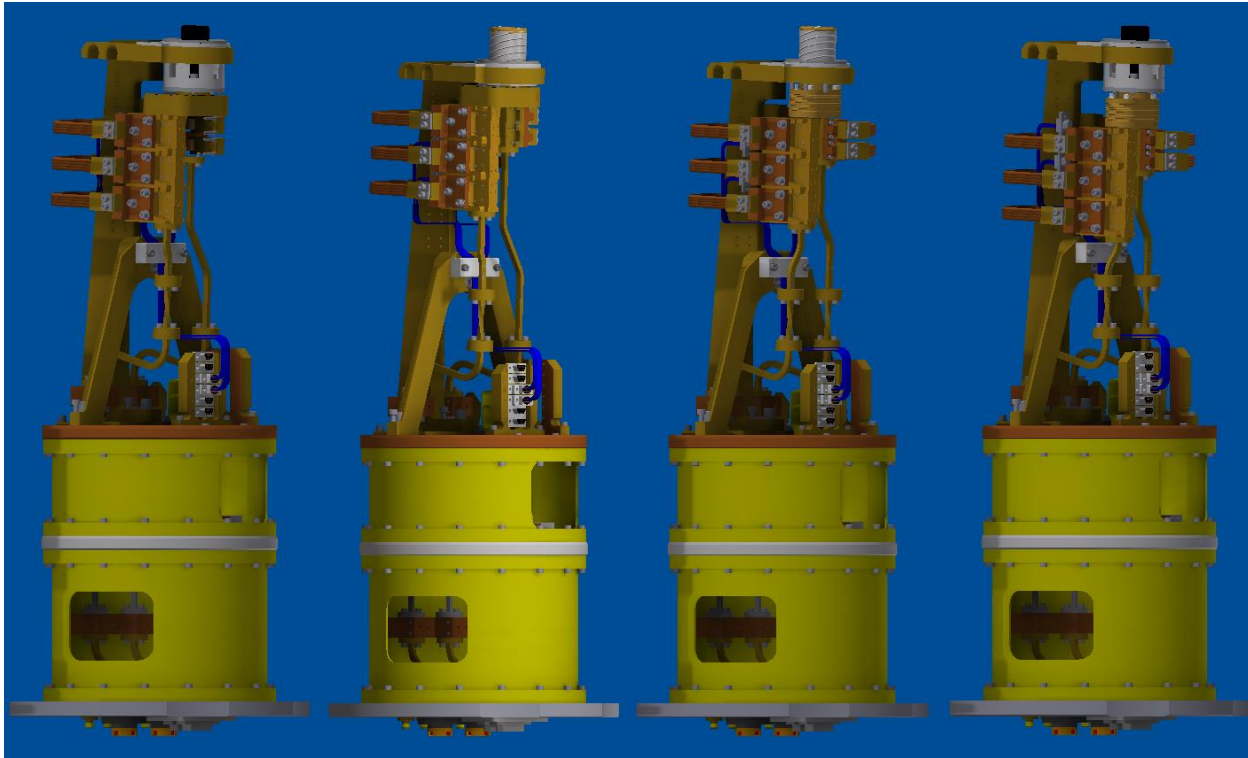

Figure 1. Sketch of the four variants of the B23 cartridge prototype configuration. From left to right: Variant-1: Horn UdC + OMT UdC; Variant-2: Horn INAF + OMT UdC; Variant-3: Horn INAF + OMT INAF; Variant-4: Horn UdC + OMT INAF. The pictures are shown the configurations with 3 UMAN amplifiers on Pol-0 and 2 INAF/JPL amplifiers on Pol-1.

6 Product tree

Hereafter the product tree of the B23 cartridge integration and test is reported in Figure 2.

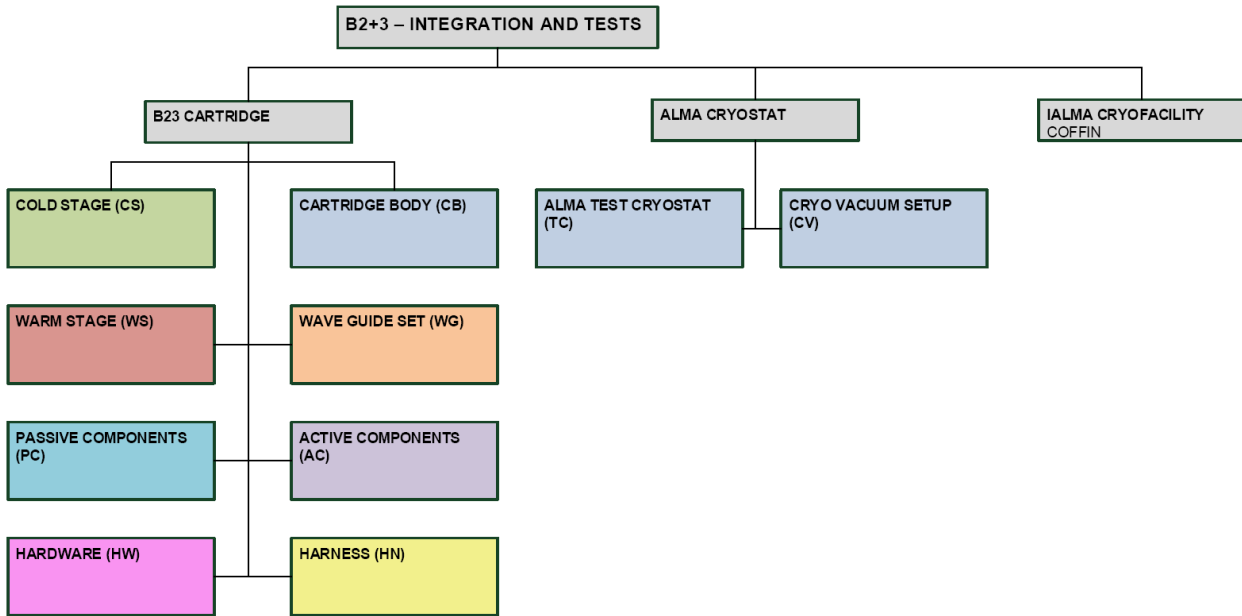

Figure 2. Band 2+3 Cartridge prototype integration and test.

7 Bill of Materials

The bill of materials has been based on the BOM provided by Chalmers

Table 1. Bill of Material

ITEM	PT	QTY	PART NUMBR	DESCRIPTION	RES	PROVIDER
Band 2+3 Cartridge prototype						
1	CB	1	NOVA058_B23	ALMA B5 300K Plate (Production)	ESO	NOVA
2	CB	1	ALMA-01-01-02	110K stage flange (Modified B5 Pre-Production)	ESO	GARD
3	CB	1	ALMA-01-01-03	15K stage flange (Modified B5 Pre-Production)	ESO	GARD
4	CB	1	ALMA-01-01-05	Thermal isolation 300K-110K (B5 Pre-Production)	ESO	GARD
5	CB	1	ALMA-01-01-06	Thermal isolation 110K-15K (B5 Pre- Production)	ESO	GARD
6	WS	1	30-001-03c	DC-wires 110K heatsink Cover	INAF	UNIMI
7	WS	1	ALMA-2-09	Waveguide 110K heatsink fixture	INAF	UNIMI
8	WS	1	ALMA-2-06	Waveguide 110K heatsink Cover 1	INAF	UNIMI
9	WS	1	ALMA-2-10	Waveguide 110K heatsink Cover 2	INAF	UNIMI
10	WS	1	ALMA-2-07	Waveguide 110K heatsink Cover 3	INAF	UNIMI
11	WS	2	ALMA-2-08	Waveguide 110K heatsink Cover 4	INAF	UNIMI
12	WS	2	ALMA-2-11	Waveguide 110K heatsink Clamp, Part 1	INAF	UNIMI
13	WS	2	ALMA-2-12	Waveguide 110K heatsink Clamp, Part 2	INAF	UNIMI
14	WS	3	ALMA-2-13	110 K Heat sink foil for waveguides	INAF	UNIMI
15	CS	1	ALMA-2-14	15 K Cover and Heat sink mounting point	INAF	UNIMI
16	CS	6	ALMA-2-20	15 K Heat sink foil for waveguides	INAF	UNIMI
17	CS	1	ALMA-2-16	15 K Cover DC Cable Feedthrough	INAF	UNIMI
18	CS	1	ALMA-2-15	15 K DC 9-Pin Connectors Heat Sink 1	INAF	UNIMI
19	CS	1	ALMA-2-15b	15 K DC 15-Pin Connectors Heat Sink 2	INAF	UNIMI
20	CS	1	ALMA-2-02b	15 K Receiver Support, Part 1	INAF	UNIMI
21	CS	1	ALMA-2-03d	15 K Receiver Support, Part 2	INAF	UNIMI
22	CS	1	ALMA-2-01v	15 K Receiver Support, Part 3	INAF	UNIMI
23	CS	3	ALMA-2-19b	Heat Sink U-Man AMP	INAF	UNIMI
24	CS	2	ALMA-2-21c	Heat Sink INAF AMP	INAF	UNIMI
25	CS	1	load v2	Horn UDC Load Bracket	INAF	UNIMI
26	CS	1	load v2 INAF	Horn INAF Load Bracket	INAF	UNIMI
27	CS	1	Assembly absorber UDC Bracket	Assembly, Absorber + UdC Load Bracket	ESO	TBD
28	CS	1	Assembly absorber INAF Bracket	Assembly, Absorber + INAF Load Bracket	ESO	TBD
29	CS	1	ALMA-2-18b	UdC Horn Adapter Bracket	INAF	UNIMI
30	HN	1	ALMA-2-32	DC Cable Guide 15K, Part 1	INAF	UNIMI
31	HN	1	ALMA-2-33	DC Cable Guide 15K, Part 2	INAF	UNIMI
32	HN	2	ALMA-2-22	DC Cable Heat Sink 110K, Part 1	INAF	UNIMI
33	HN	2	ALMA-2-23	DC Cable Heat Sink 110K, Part 2	INAF	UNIMI
34	CB	1	ESD protection boards	ESD-cards, Band5 Production Unit	ESO	NOVA
35	WG	2	WR-1-assembly	WAVEGUIDE OUTPUT (Common Waveguides 300K to 15K), 2xH-3; 2xH-4; 2xSS-WR10	INAF	PMS, RST inc.
36	WG		WR10-1	WR10 VARIANT1	INAF	PMS
37	WG		WR10-2	WR10 VARIANT2	INAF	PMS
38	WG		WR10-3	WR10 VARIANT3	INAF	PMS
39	WG		WR10-4	WR10 VARIANT4	INAF	PMS
40	CB	2	NOVA067	Waveguide Bulkhead Flange WR10	ESO	Aerowave
41	CB	2	NOVA068	Feedthrough Clamp Plate WR10	ESO	Aerowave
42	CB	2	S-00159-0	Mica Plate vacuum feedthrough	ESO	Aerowave
43	LNA	3		U-Manchester Amplifier	UMAN	UMAN
44	LNA	2		INAF Amplifier	INAF	INAF/IASF



ITEM	PT	QTY	PART NUMBR	DESCRIPTION	RES	PROVIDER
45	PC	1		UdC Horn	UdC	UdC
46	PC	1		INAF Horn	INAF	INAF/OAA
47	PC	1		UdC OMT	UdC	UdC
48	PC	1		INAF OMT	INAF	INAF/IASF
49	HN	1	ALMA-2-34	DC-wires 110K heatsink Cover Lid	INAF	EXT. COMP.
50	CS	10	ALMA-2-35	15K Amplifier heatsink Clamp Plate	INAF	EXT. COMP.
51	CB	1	ALMA DC Feedthrough	ALMA 2x51 pin GlenAir DC Feedthrough	ESO	NOVA
52	CS	5	P7-502-10cm	Heat sink cooling braid for AMP	INAF	INAF
53	CB	4	SMA Feedthrough	SMA Feedthrough or blank	ESO	TBD
54	HW	16	ANSI B18.3 - No. 2 - 56 UNC - 3/8 HS HCS	Hexagon Socket Head Cap Screw		
55	HW	76	ANSI B18.3 - No. 4 - 40 UNC - 1/4 HS HCS custom	Hexagon Socket Head Cap Screw		
56	HW	2	ASME/ANSI B18.3.5M - M3x6(2)	Broached Hexagon Socket Flat Countersunk Head Cap Screws - Metric		
57	HW	112	BS 4168 _ Part 1	Hexagon Socket Head Cap Screw - Metric M2 x 8		
58	HW	208	BS 4463 - M3 (DIN 137B)	Crinkle washers for general engineering purposes metric series	INAF	
59	HW	6	BS 4463 - M4 (DIN 137B)	Crinkle washers for general engineering purposes metric series	INAF	
60	HW	6	CNS 4557 - M4 x 16 (DIN7984)	Hexagon Socket Head Cap Screws Shallow Head with Pilot Recess for Wrench Key	INAF	
61	HW	4	IS 6735 - 2,5 (DIN127B)	Fasteners - Spring lock washers for screws with cylindrical heads - Specification	INAF	
62	HW	63	IS 6735 - 3 (DIN127B)	Fasteners - Spring lock washers for screws with cylindrical heads - Specification	INAF	
63	HW	8	IS 6735 - 5 (DIN127B)	Fasteners - Spring lock washers for screws with cylindrical heads - Specification	INAF	
64	HW	4	ISO 4762 - M2,5 x 10	Hexagon Socket Head Cap Screw	INAF	
65	HW	87	ISO 4762 - M3 x 12	Hexagon Socket Head Cap Screw	INAF	
66	HW	92	ISO 4762 - M3 x 16	Hexagon Socket Head Cap Screw	INAF	
67	HW	64	M3 x 16	Silver plated Vented Screw, Supplied with Cartridge		
68	HW	8	ISO 4762 - M3 x 20	Hexagon Socket Head Cap Screw	INAF	
69	HW	6	ISO 4762 - M3 x 5	Hexagon Socket Head Cap Screw	INAF	
70	HW	10	ISO 4762 - M3 x 8	Hexagon Socket Head Cap Screw	INAF	
71	HW	3	ISO 4762 - M4 x 20	Hexagon Socket Head Cap Screw	INAF	
72	HW	9	ISO 4762 - M5 x 20	Hexagon Socket Head Cap Screw	INAF	
73	HW	4	ISO 7089 - 2,5 - 140 HV	Plain washers - Normal series - Product grade A	INAF	
74	HW	63	ISO 7089 - 3 - 140 HV	Plain washers - Normal series - Product grade A	INAF	
75	HW	8	ISO 7089 - 5 - 140 HV	Plain washers - Normal series - Product grade A	INAF	
76	HW	8	ISO 7092 - ST 3 - 140 HV	Plain washers-Small series-Product grade A	INAF	
77	HW	8	ISO 8734 - 2 x 8 - A	Parallel pins of hardened steel and martensitic stainless steel (Dowel pins)	INAF	

ITEM	PT	QTY	PART NUMBR	DESCRIPTION	RES	PROVIDER
78	HW	4	pin D3.5 8	Parallel pins of hardened steel and martensitic stainless steel (Dowel pins)	INAF	
79	HW	8	Small head screw #4-40 1.4inch		INAF	
80	WG	4	WR 10-WR15 transition(1)	WR10 to WR15 transition, Part 1 (Part of WAVEGUIDE OUTPUT, WR-1-assembly)	INAF	PMS
81	WG	4	WR 10-WR15 transition(2)	WR10 to WR15 transition, Part 2 (Part of WAVEGUIDE OUTPUT, WR-1-assembly)	INAF	PMS
82	HN		N/A	DC-cables 300K-15K	ESO	Tekdata
83	HN		N/A	DC cables 15K-LNA	ESO	In house made
84	HN		N/A	DC cables 15K- temperature sensors	ESO	In house made
85	WG	2	10-1790AU	90Degree Twists	INAF	RST inc.
86	CRYO	2	N/A	O-ring 300K flange	ESO	
87	CRYO	3	N/A	Temperature Sensors for the Cartridge	ESO	
88	CRYO	1	DT670	Additional temperature Sensors	INAF	
89	WG	1	iALMA-TEC-DWG-IAB-005 REV A	WR10-T0 straight section	INAF	
90	WG	1	iALMA-TEC-DWG-IAB-006 REV A	WR10-T1 straight section	INAF	
91	WG	1	iALMA-TEC-DWG-IAB-007 REV A	WR10-T2 straight section	INAF	
92	WG	1	iALMA-TEC-DWG-IAB-008 REV A	WR10-T3 straight section	INAF	
Test Setup						
1		1	iALMA-TEC-DWG-IAB-001 REV. C	110 K filter support modified	ESO	Entleutner
2		1	iALMA-001-P-0-0008	15K filter upper clamp modified	ESO	Entleutner
3		1	iALMA-TEC-DWG-IAB-003 REV A	ALMA test Cryostat 110K shield filter adapter	ESO	Entleutner
4		1	iALMA-TEC-DWG-IAB-002 REV. A	ALMA test Cryostat 15K shield filter adapter	ESO	Entleutner
5			iALMA-TEC-DWG-IAB-004 REV. A	ALMA test Cryostat window adapter	ESO	Entleutner
6		1	N/A	Pressure Gauge power supply cable	INAF	IASF
7		1	N/A	ALMA test cryostat Drawings and Shipment info	ESO	ESO
8		1	N/A	Transport BOX to be retained	INAF	INAF
9		1	N/A	Ship Band 5 prototype cartridge to INAF	ESO	ESO
10		1	N/A	Confirm operation without 4K interface	ESO	
11		1	N/A	Drawings of the cryostat to be confirmed (e.g. 15mm difference in the length)	ESO	ESO
12		1	N/A	Check positions (~few mm) of the filters in the cryostat	INAF	
13		1	N/A	O-ring for the window	ESO	
14		1	N/A	Compatibility with INAF compressors	INAF	IASF
15		1	N/A	Arrange compressor lines and vacuum pumps (LT)	INAF	
16		1	N/A	Temperature sensors and read out to be provided	ESO	ESO

8 Waveguide Manufacturing

The detailed product tree breakdown of the entire waveguide set is reported in Figure 1. From the original, the set was modified to accept alternatively the INAF/JPL, the LNF amplifiers, or a combination of the two.

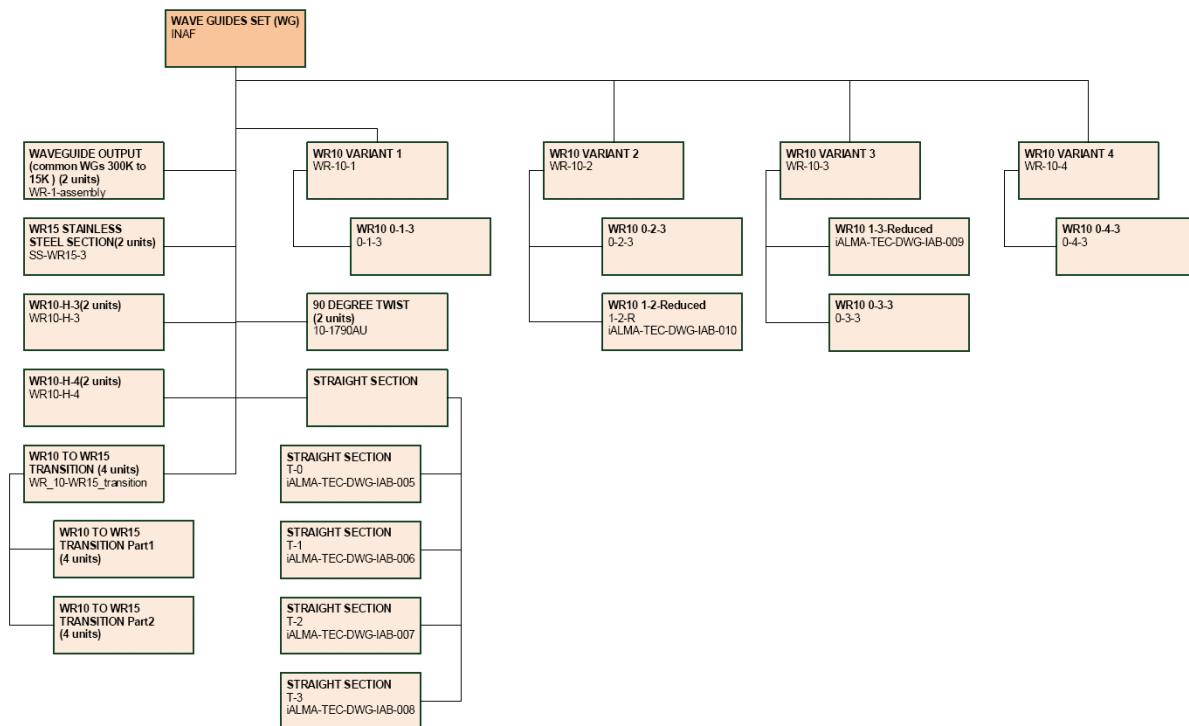

Figure 3. Detailed view of the product tree of the waveguides (WG).

8.1 Curved Copper sections

Custom copper waveguides and WR15-WR10 transitions were manufactured in Italy by Pasquali Microwave Systems (PMS)¹. Originally planned to be manufactured by electro-forming technique, the waveguides were actually manufactured by bending straight section of copper WR10 standard bars. The mechanical bending technique was the only way compatible with the schedule of the project. A set of electroformed waveguides is under finalization to possibly improve cartridge performance. Waveguides were tested at INAF/OAA as reported in [RD3]

¹ <http://www.pasquali-microwavesystems.com>

8.2 WR10 – 90 degrees Twists

The two 90 degrees twists were acquired from Aerowave inc², through his representative Radar System Technology inc (RST)³. They are coin-silver gold plated outside sections. They have been measured in INAF/OAA and performances reported in [RD3].

8.3 WR10-WR15 Transformers

The transformers permits to match the copper WR10 waveguides with the WR15 stainless steel waveguides that show better performances in terms of losses with respect the corresponding WR10 stainless steel sections.

Transformers were designed by Chalmers/GARD and manufactured by PMS in Cu-Tellurium as specified. No criticalities were identified apart from spikes found basically in the A-165950-SN201 when tested in pairs with others. Resonances disappeared when connected with the stainless steel section.



Figure 4. WR10-WR15 Transitions as arrived at INAF (left) and as mounted on the cartridge (right).

8.4 WR15 and WR10 Stainless steel Waveguides

WR15 Stainless steel waveguides were difficult to procure in Europe, even the bare tube. We ordered the two 150 mm long Stainless Steel 0.010" in thickness flanged sections to RST that delivered the units on 16/12/2016. On 21 December 2017, they were tested together with the transformers at INAF/OAA to select the best combination in terms of RF performances. As a backup solution a pair of WR10 180 mm long Stainless Steel 0.010" in thickness has manufactured by PMS and tested at INAF/OAA. The raw WR10 stainless steel waveguides were provided to PMS by INAF/IASF.

These components were not critical from the technical point of view. Because of the difficulties to find in Europe the WR15 stainless steel raw waveguide, the future procurement strategy should be carefully studied and delivery time should be accounted for future developments.

² <http://www.aerowave.net/>

³ <http://www.rst-inc.com/>

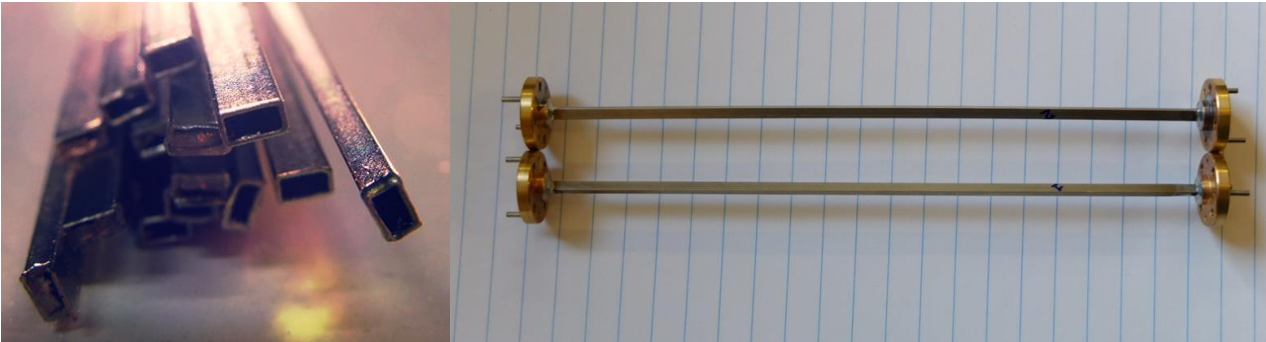

Figure 5. Left: WR10 stainless steel raw waveguides at Cryowaves IANF/IASF laboratory. Right: backup solution for stainless steel waveguides for the cartridge manufactured by PMS using 180mm long WR10 SS-waveguides.

8.5 Straight Copper Sections

Namely WR10-T0, WR10-T1, WR10-T2, WR10-T3 are the straight waveguide sections designed to permit the use different amplifiers combinations. They were built using standard copper WR10 raw waveguide and soldered with standard brass UG387/U flanges. The manufacturing drawings are listed hereafter and reported in Annex B:

- WR10-T0: iALMA-TEC-DWG-IAB-005
- WR10-T1: iALMA-TEC-DWG-IAB-006
- WR10-T2: iALMA-TEC-DWG-IAB-007
- WR10-T3: iALMA-TEC-DWG-IAB-008

Results of the tests are reported in [RD3].

9 Cartridge Body

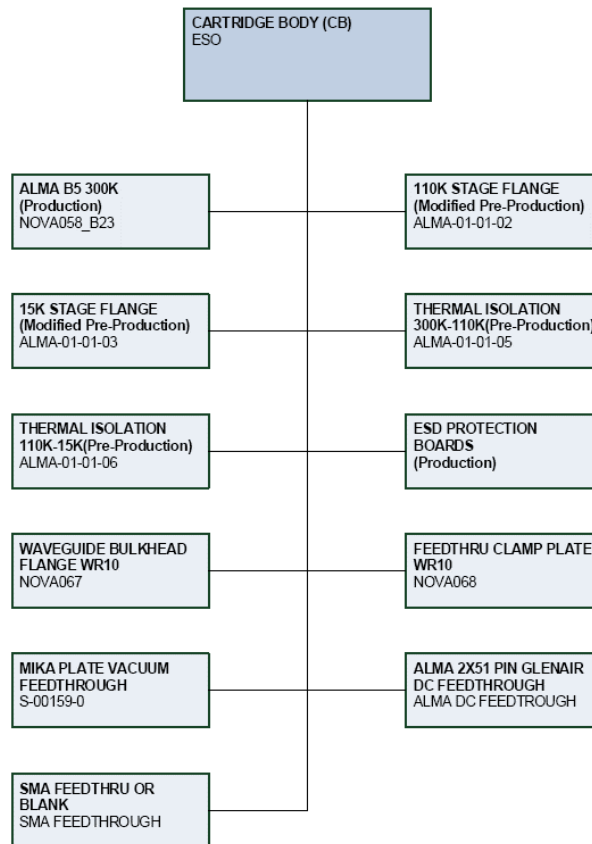

Figure 6. Detailed view of the product tree of the Cartridge body (CB)

The cartridge body was a Standard ALMA cartridge type, a prototype from Band 5 pre-production project. The cartridge body includes the 15K stage flange (ALMA-01-01-03) from band 5 pre-production specifically modified, the 110K stage flange (ALMA-01-01-02) from band 5 pre-production specifically modified, the 15-110K thermal isolator (ALMA-01-01-06) from band 5 pre-production, the 300K flange (NOVA058_B23) from band 5 production, the 110K-300K thermal isolator (ALMA-01-01-05) from band 5 Pre-production, the two WR10 feedthrough (NOVA067 + NOVA068 + S-00159-0), and the ALMA ESD protection Boards. All these components included all the special screws needed to mount the cartridge body. The procurement was under the responsibility of ESO. INAF did not manufacture pieces of the Cartridge Body.

10 Cold Stage

The Cold stage is composed by all the parts that are supposed to work at 15K except the waveguides and passive components. The product tree is shown in Figure 7.

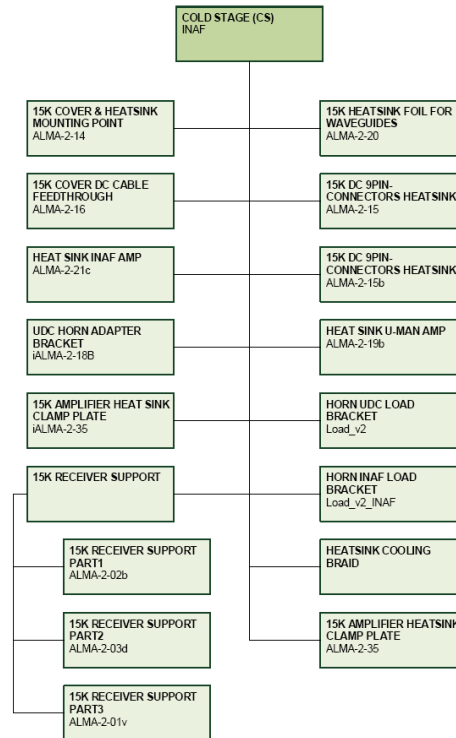

Figure 7. Detailed view of the product tree of the Cold Stage (CS).

All these parts were fabricated at the Workshop of the Physics Department of University of Milano. Chalmers/GARD groups provided the Oxygen Free Copper CW008A material for the manufacturing. The available copper raw material was the bare necessity for a single production, thus, to avoid criticalities and delay in fabrication, the manufacturing procedure was the following:

- Each unit was firstly fabricated in aluminium to identify any possible error in CNC software, to develop dedicated tools when needed and to identify criticalities in the manufacturing process.
- As the aluminium pieces were fabricated successfully, the final copper units were manufactured.

Therefore, the manufacturing time for copper pieces was twice. Even though this procedure was critical from the schedule point of view, it reduced the risks in manufacturing process since avoided any possible problems in Copper pieces.

Although the gold plate was foreseen for the copper pieces, the plating was not performed mainly for schedule reasons. The copper surfaces were polished to guarantee a good reflectivity in the cryogenic environment.

10.1.1 15 K receiver support

This assembly is composed by the three parts, namely ALMA-2-02b (Part 1), ALMA-2-03d (Part 2), and ALMA-2-01v (Part 3). The assembly is the support for amplifiers, OMT and FH providing the alignment of the optics w.r.t the lens and providing the thermal contact with the 15 K flange.

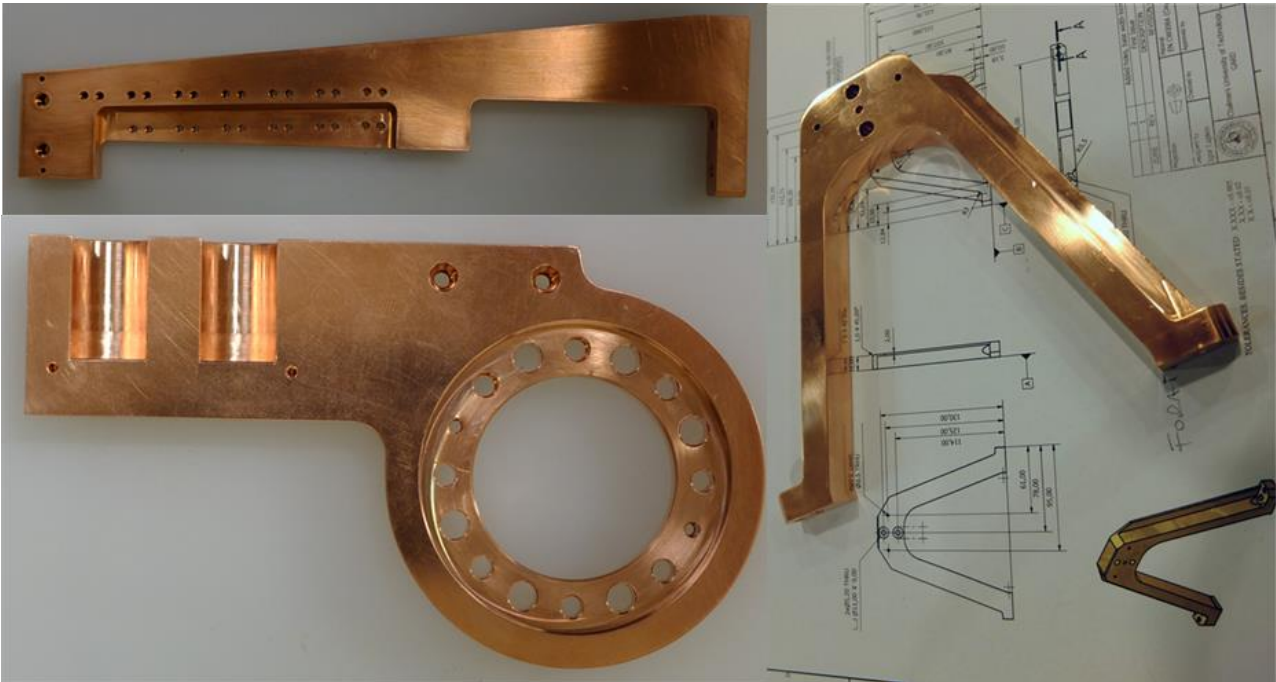

Figure 8. pieces that constitutes the 15K receiver support, namely the Part 1 (left upper), the Part 3 (left bottom), and the Part 2 (right).

The following Non Conformity Reports were identified:

ID	Date	Part Number	Title
NCR-iALMA-01	21/11/2016	ALMA-2-03d	Design of part 2 not compliant with the milling machine head
NCR-iALMA-16	20/12/2016	ALMA-2-01v	Diameter of the hole to accept the FH too small to accept the horn (29.91 mm instead of 30.0)
NCR-iALMA-15	14/12/2016	ALMA-2-01v	Pin Location outside specs

Since the alignment of the horn is determined by these components, the three parts were measured in an opto/mechanical measurement machine at UNIMI-WS using different methods:

- 'dia': Measurement with optical sensor with the object illuminated by a diasopic light, i.e. coaxial to the sensor and coming from back
- 'led': measurement with optical sensor with the object illuminated by a concentric light from front and tilted.

- 'grad': measurement with optical sensor specially for edges using the light gradient with respect to a reference geometry.

The measurements were restricted to check the holes positions of the alignment pins with respect the reference coordinate systems as indicated in Figure 9, Figure 10, and Figure 11. The extensive measurement report is reported in Annex D, while a summary is presented in

Table 2.

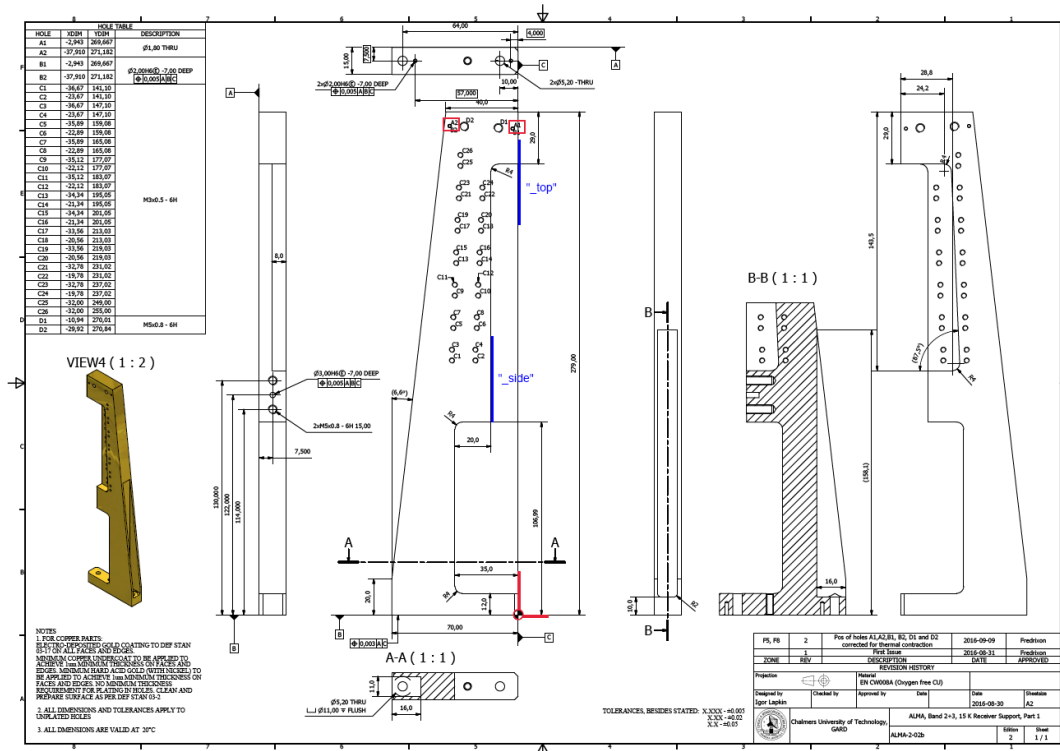

Figure 9. Reference system and measured quantities for the ALMA-2-02b 'part 1' support

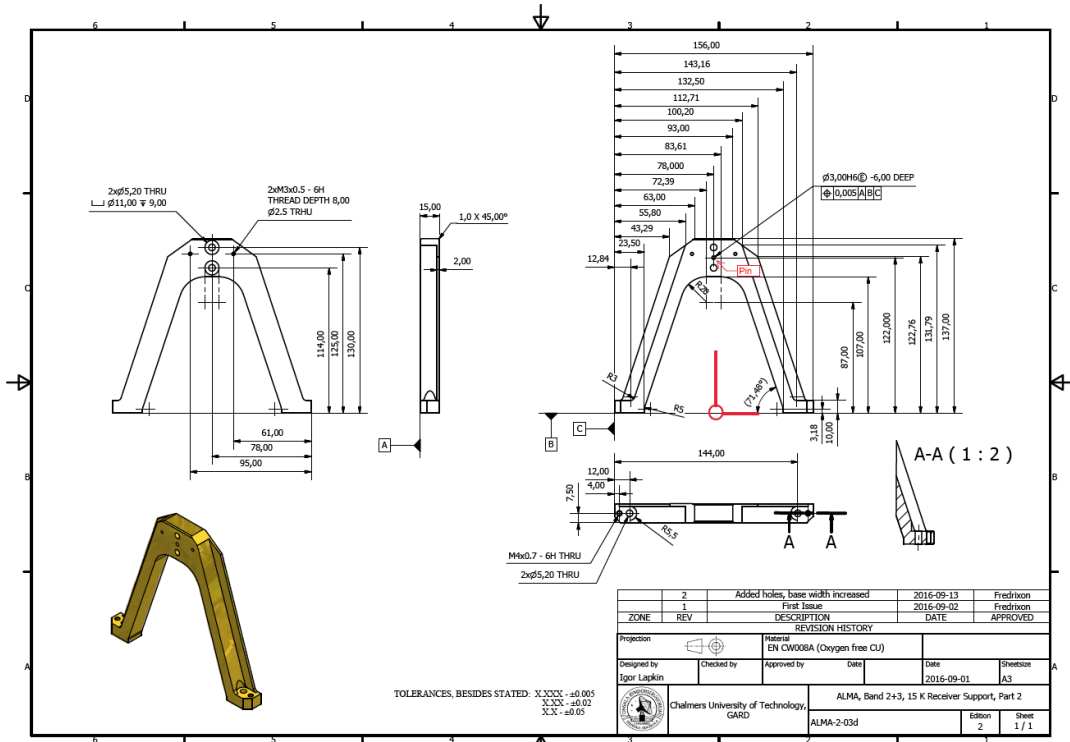

Figure 10. Reference system and measured quantities for the ALMA-2-03d 'part 2' support

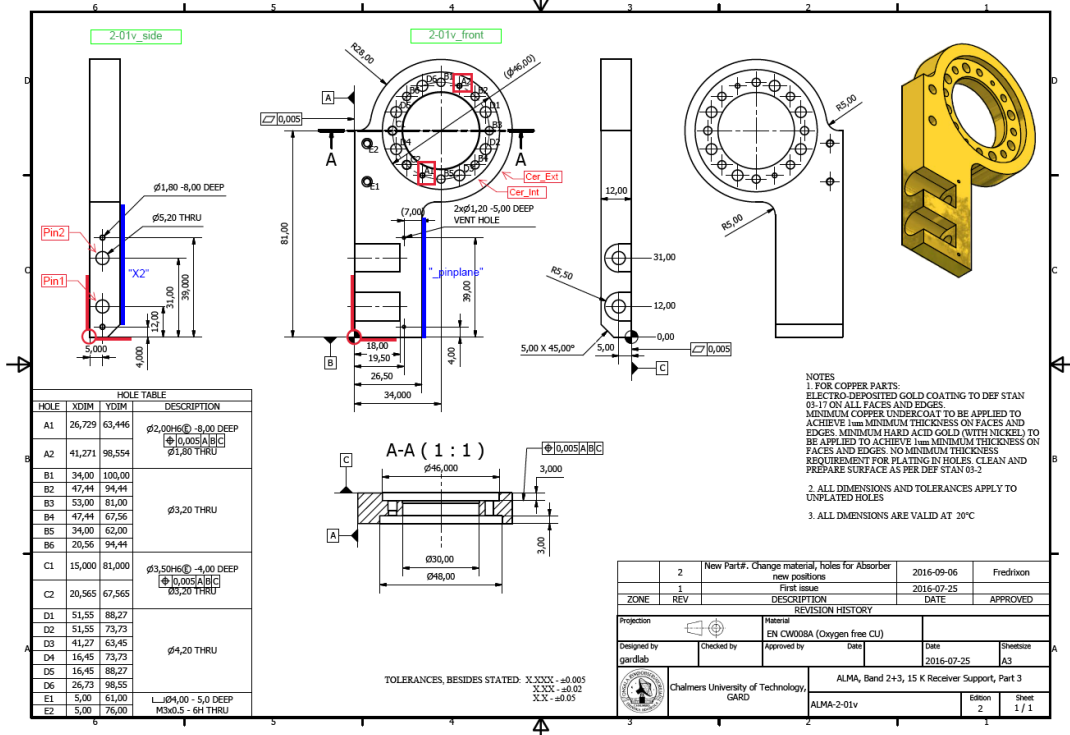

Figure 11. Reference system and measured quantities for the ALMA-2-01v 'part 3' support

Table 2. Measured pin position relevant for alignment of the feedhorn.

Part number	Hole ID	Measured coord.	Design coord.
ALMA-2-02b	A1	X,Y = 26.782,63.445	26.729,63.446
	A2	X,Y = 41.319,98.563	41.271,98.554
	Pin1	X,Y = 5.017,4.003	5.000,4.000
	Pin2	X,Y = 39.001,4.902	39.000,5.000
	Pin2 X2	X = -6.997	-7.000
	Pin1 X2	X = -7.103	-7.000
	A1 pinplane	X = 0.221	0.229
	A2 pinplane	X= 14.760	14.771
	Cer Int	X,Y = 34.037,81.020	34.000,81.000
Cer Ext	X,Y = 34.047,81.008	34.000,81.000	
ALMA-2-03d	Pin	X,Y = -0.028,121.970	0.000,122.000
	Origin X-coor	X = 77.974	78.000
ALMA-2-02b	A1	X,Y = -3.074,269.7095	-2.943,269.667
	A2	X,Y = 38.060, 271.210	37.910,271.182
	A1 side	X = 12.032	12.057
	A1 top	X = -2.967	-2.943
	A2 side	X = -22.954	-22.910
	A2 top	X = -37.954	-37.910

10.1.2 Heatsink, Covers, and fixture

Cold stage included also covers and heat sink for amplifiers and connectors. The cover to attach the heatsink of the waveguides (ALMA-2-14) was fabricated in specifications.

The ALMA-2-16 was manufactured in specifications; then it was modified to be compatible with band 9 harness (see NCR-iALMA-18). Lastly, it was not mounted on the cartridge.

The ALMA-2-20 heat sink foil for waveguides was fabricated together with the ALMA-2-13 in aluminium by chemical etching process. We decided to adopt this technique for schedule and costs reasons, because the difficulty to procure copper foil. An aluminium foil was printed (see Figure 12) and a bending template was manufactured by 3D printer. Based on a preliminary estimation using the different material thermal properties we have verified that the impact of using aluminium rather than copper is not critical. In fact, the estimated temperature gradient between the WR15-WR10 transformer and the 15K flange is about 0.7 Kelvin.

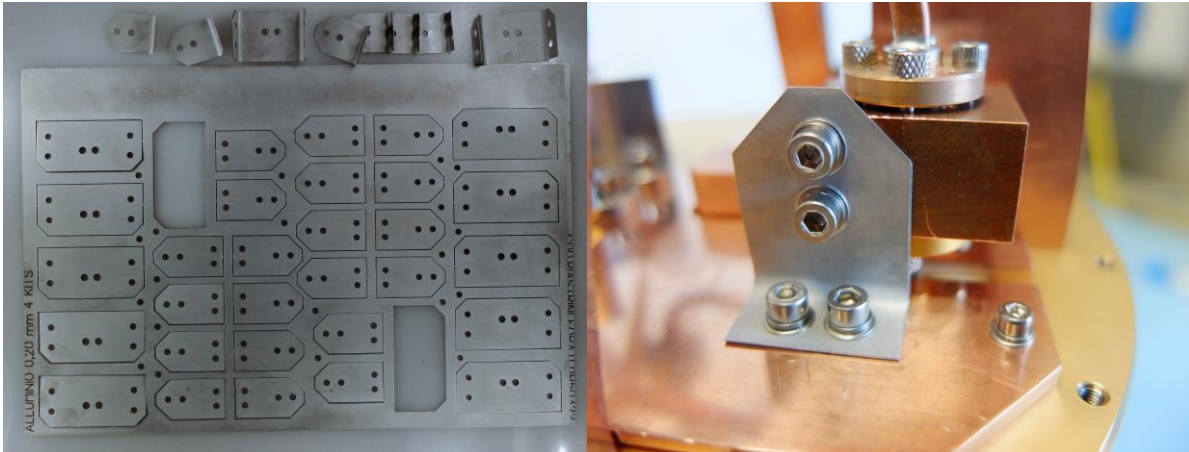

Figure 12. Aluminium foil for waveguide heat sink (left) and the ALMA-2-20 as mounted on the cartridge.

Two connector's heatsink has been manufactured at UNIMI-WS according to ALMA-2-15 and ALMA-2-15b drawings as reported in Annex A. Because of the availability of different cryogenic harness and connectors, we used only one heatsink ALMA-2-15b with an interface adapter to fix the band 9 harness with the heatsink itself. Because of the urgency, the interface was fabricated at Cryowave lab using the available copper plate (see Figure 13).

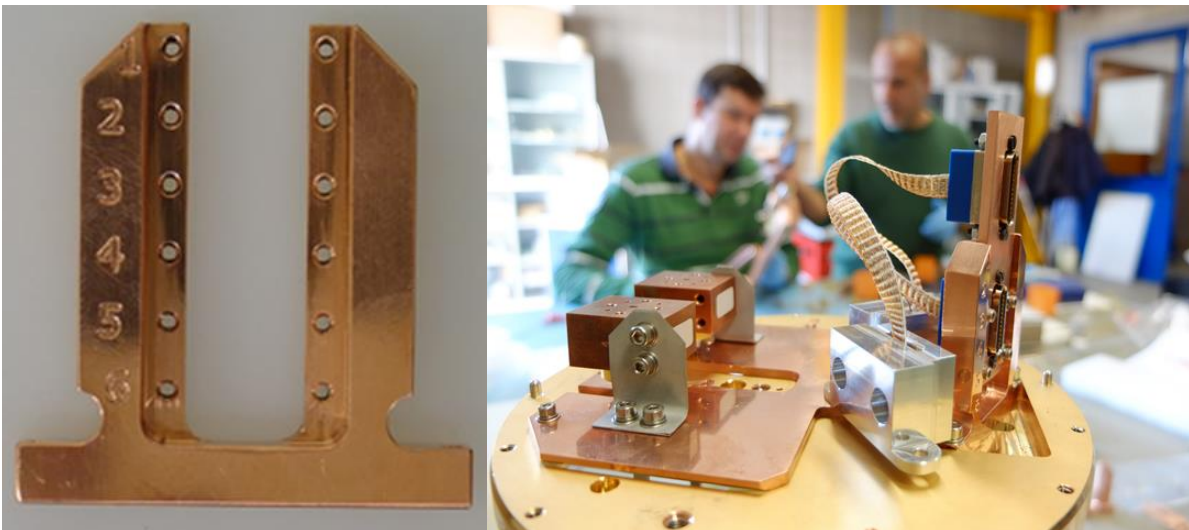

Figure 13. One of the two connector's heatsink (left) and the same connector adapted for integration with Band 9 harness (right).

10.1.3 Horn brackets and adapters

The horn brackets are foreseen to surround the horn mouth by absorbing material. These parts were fabricated at the Workshop of the University of Milano and delivered at the same time with others parts. They are the

Load_v2 for the UdC horn and the Load_v2_INAF for the horn developed at INAF/OAA. They will be possibly used in future tests.

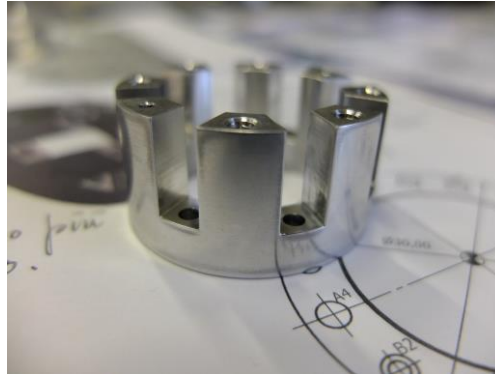

Figure 14. Adapter of the UdC feed horn providing the correct positioning of the UdC horn in the cartridge

For the UdC horn, an adapter has been manufactured according to ALMA-2-18b drawing. The unit showed an internal diameter too small to accept the horn since the measured internal diameter was at 29.85mm instead of 30.00mm as specified in the drawings (see NCR-iALMA-17). The unit was modified in the INAF/OAA workshop on December 21st, together with the ALMA-2-01v (NCR-iALMA-16). The thickness of the piece has been measured to be in the worst case at 20.665mm (specified at 20.680mm). Thus, the displacement of the UdC horn with respect to the horn interface is 0.015mm at maximum.

10.1.4 Amplifiers heatsink and thermal braid

Amplifiers are connected to the thermal links by heatsinks. They are the ALMA-2-19b for the UMAN amplifiers and the ALMA-2-21c for the INAF/JPL or alternatively LNF amplifiers. The manufactured units are shown in Figure 15.

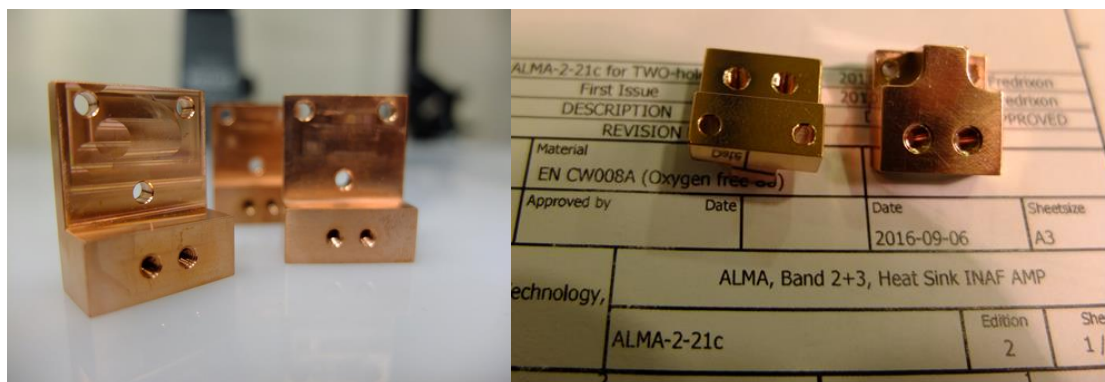

Figure 15. Heatsink for UMAN amplifiers (left) and for INAF/JPL - LNF amplifiers (right) Thermal links to connect the amplifiers to the 15K receiver support assembly was originally selected by Chalmers / GARD group from Technology Application inc. (TAI) company, in particular the model P7-502-10cm. Because of the high costs for each unit, in this phase of the project, we decided to build the thermal links in house, using a copper braid soldered

with copper pieces. We measured the thermal conductivity of our units from 6K to 20K as described in [RD6]. We found a conductivity of 0.32 ± 0.08 W/K compared with 0.44 W/K (both at 20K) of the commercial thermal link. This was considered acceptable for the goal of the cartridge prototype.



Figure 16. Example of thermal braid to thermally connect the

The 15K amplifier heatsink clamp plates (ALMA-2-35) to connect the thermal links with amplifier's heatsink were not manufactured. Instead, we used standard washers.

11 Warm Stage

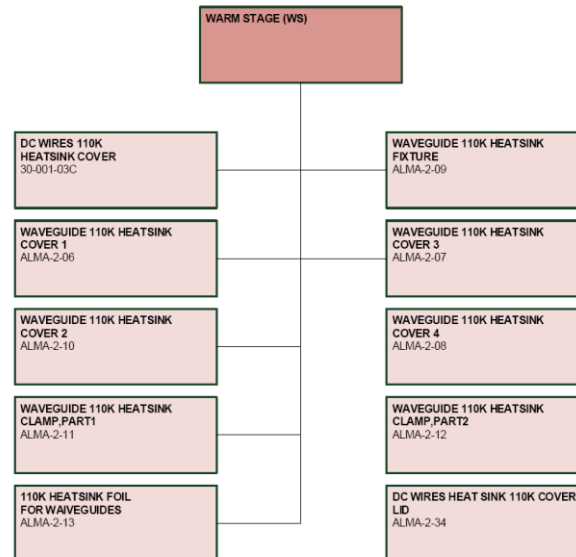

Figure 17. Detailed view of the product tree of the Warm Stage (WS).

Warm stage includes all the parts, mainly heatsink, connected to the 110K cartridge flange.

The two aluminium covers (ALMA-2-08) were fabricated using 1mm in thickness (instead of 0.5mm) aluminium foil. The ALMA-2-13 was fabricated in aluminium with chemical etching process, as reported and shown in Paragraph 10.1.2. In this case the temperature gradient using aluminium foils was estimated to be negligible due to the much lower thermal conductivity difference between aluminium and copper at this higher temperature.

The other pieces, namely 30-001-03C, ALMA-2-06, ALMA-2-07, ALMA-2-09, ALMA-2-10, ALMA-2-11, ALMA-2-12, and ALMA-2-34 were fabricated as specified in drawings.

12 Passive Components

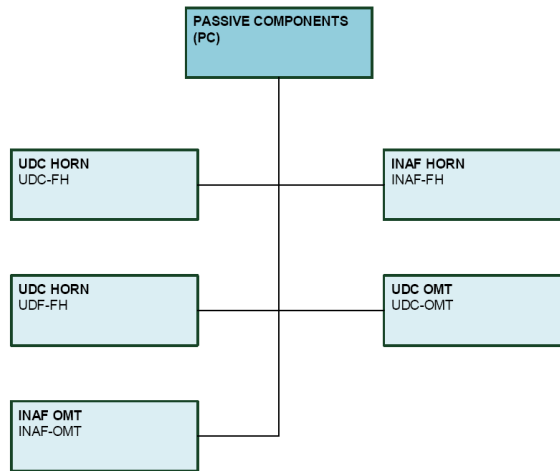

Figure 18. Detailed view of the product tree of the Passive Components (PC).

Passive components (Feed horns and OMTs) were already fabricated for warm optical tests. They were developed according to schedule and milestones of the phase A of the project. For INAF feedhorn and OMT we refer to the Passive Components Final Report [RD7].

13 Active Components

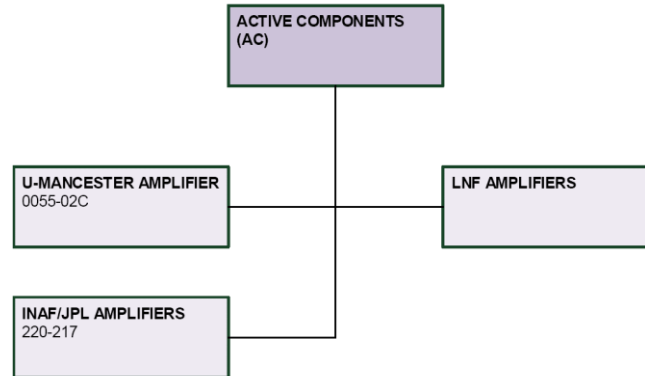

Figure 19. Detailed view of the product tree of the Active Components (AC).

The cartridge has been designed to accept two INAF/JPL amplifiers in Polarization 1 and two/three UMAN amplifiers in Polarization 0. Polarization 0 and 1 are defined according to ALMA standards definition for polarization.

After the modification of waveguide routing, the cartridge was able to accept also the LNF amplifiers in polarization 1 as well as a combination of LNF and INAF/JPL amplifiers.

14 Harness

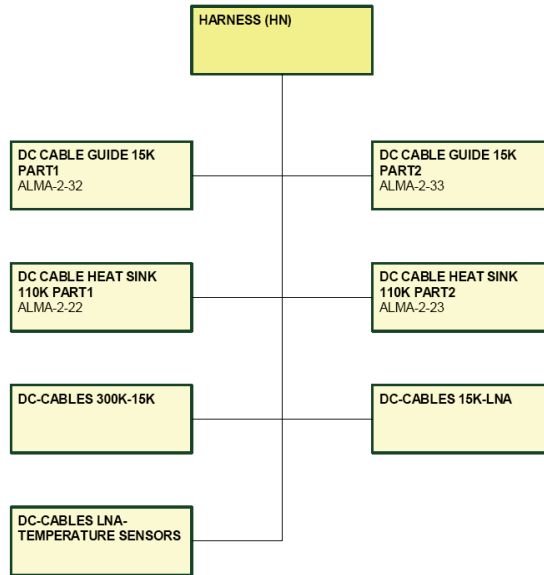

Figure 20. Detailed view of the product tree of the Harness (HN).

All the harness related components, ALMA-2-32, ALMA-2-33, ALMA-2-22, and ALMA-2-23 were fabricated as specified in the related drawings. For the cartridge, the band 9 harness has been used. This required a special adapter (not foreseen) for connectors, as already reported in Paragraph 10.1.2) while heatsinks for cables were already mounted and fixed on available threads on the CCA flanges.

In addition, for UMAN amplifiers, two voltage divider units were setup according to bias specifications. The electrical scheme is reported in Figure 21. Resistors (1/4 W TC<200ppm/°C) have been placed inside the cryostat.

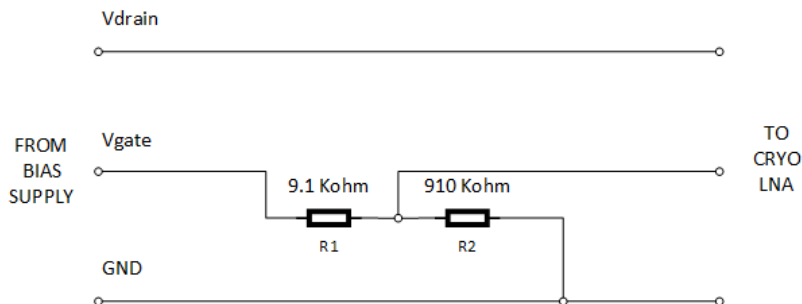

Figure 21. Electrical scheme of the voltage partition unit to correctly bias UMAN amplifiers.

External harness to connect the BIAS unit outputs with the ALMA ESD protection board's inputs was also built, based on the Band 9 harness and required interfaces.

15 Hardware

Screws and washers were procured as specified by the Bill of Material (Table 1). With respect to the original BOM provided by Chalmers/GARD, we applied the changes in Table 3 for procurement difficulties in the allocated time for standards different from ISO and DIN.

Table 3. Changes in screws and washers

Item ID	original	Substituted by:
58	BS4463 - M3	M3 PHOSPHOR BRONZE DIN 137A
59	BS4463 - M4	M4 PHOSPHOR BRONZE DIN 137A
60	CNS4557 M4x16	M4x16 INOX A2 DIN 7984
61	IS6735 - 2,5	M2,5 INOX A2 DIN 127B
62	IS6735 - 3	M3 INOX A2 DIN 127B
63	IS6735 - 5	M5 INOX A2 DIN 127B

16 ALMA test Cryostat modifications

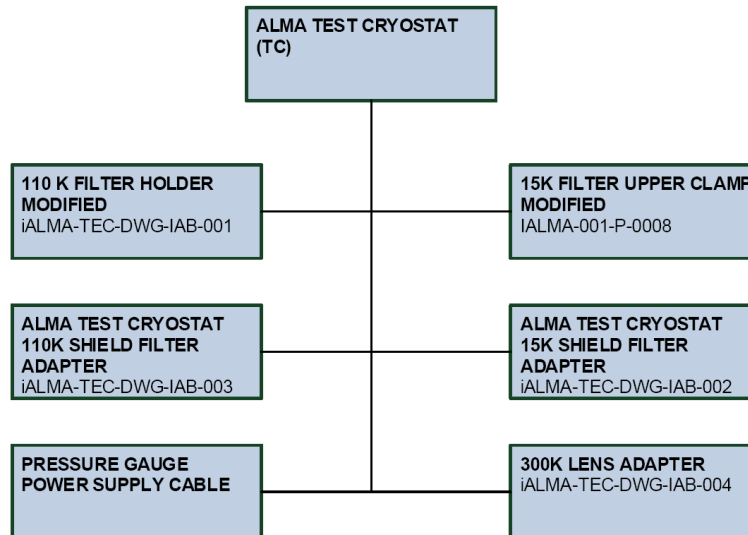

Figure 22. Detailed view of the product tree of the ALMA NAOJ test Cryostat provided by ESO (TC).

To adapt the ESO NAOJ cryostat, whose optical interfaces (filters and window positions) were specifically manufactured for ALMA band 9 CCA, we designed adapters to make the cryostat compatible with the band 2+3 prototype optical interfaces. This required the modifications of the filters holder, flanges and lens adapters. This activity required a revision of all the optical interfaces for band 2+3 resulting in the following manufacturing drawings related to flanges to permit the filters and lens mounting on cryostat shield and top cover.

- iALMA-TEC-DWG-IAB-002 REV.A for the 15K filter adapter
- iALMA-TEC-DWG-IAB-003 REV.C for the 110K filter adapter
- iALMA-TEC-DWG-IAB-004 REV.A for the 300K lens adapter

So far, a modification of the 110K filter lower clamp was also necessary to avoid interference with the filter and the shield. Moreover, the hole of the upper clamp of the 15 K was enlarged from 25mm to 60mm to ~~reduce~~ avoid any beam truncation effects. Both modifications are traced in the following drawings:

- iALMA-TEC-DWG-IAB-001 REV. C for the 110K filter holder
- iALMA-001-P-0-008 REV. A for the 15K upper clamp.

Annex C reports all the reference drawings for ALMA Test cryostat modification.



The manufacturing of these pieces was under the responsibility of ESO.

At the integration of the adapters, we found problems in the matching between the holes in the 110K filter adapter (iALMA-TEC-DWG-003) and the holes in the cryostat shield. This problem derived from a mistake on the manufacturing drawing of the unit. We made new holes in the right position without affecting the schedule of the activity. The NCR-iALMA-19 (see also iALMA-TEC-DWG-003 REV C in Annex C) traced this problem.

The power supply and cable for the pressure gauge installed into the cryostat were provided by Cryowaves laboratory using a 24 Volt power supply and a simple cable connection in agreement with supply specifications.

17 Integration

17.1 Pre-integration

A pre-integration process was performed in two steps. The first step started on 22 Nov. 2016 and ended on 24 Nov 2016 with the cryogenic dry run test on Band 5 cartridge body. During this step, one of the major problem in the integration was the position of the dowel pins that did not match the position of the holes. To permit the integration with the required alignment of the 110K and 15K flanges we decided to use a modified screw instead of pins. The alignment was necessary to guarantee the thermos/mechanical contact inside the cryostat. This was verified (visual inspection) during the cartridge mounting on the cryostat; then confirmed by the temperature reached during cooldown since the temperature of the LNAs (12.5K) about 1.5 K higher (on average) with respect the temperature of the 15K cryostat plate.

We used two M3 screws surrounded by aluminium tape avoid the movement of the screw on the dowel hole. Once aligned and the plate fixed, the modified screws were removed. A better solution was to manufacture a dowel Pin / M3 adapter as proposed by GARD but this was not compatible with the necessity to perform the cooldown on the pre-integration unit.

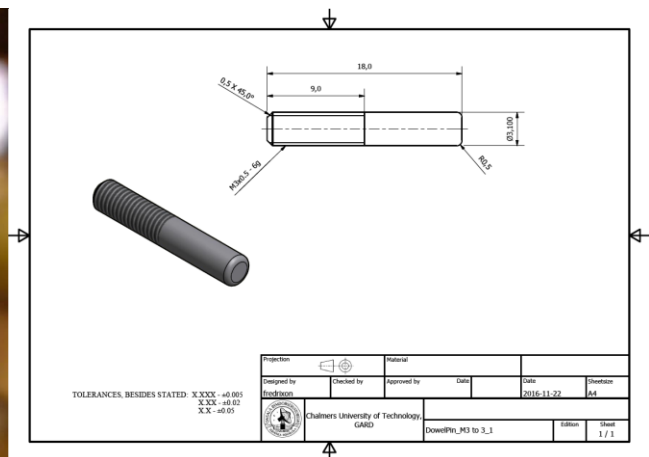

Figure 23. Left: Modified screw to permit the mounting of the cartridge body. The screw has been surrounded by well matched aluminium tape. Right: GARD proposal for alignment pin to be mounted on the M3 thread.

The second step started on 14 December 2016 and lasted for 2 days, with a preliminary configuration based on the available hardware at that moment. Only the Polarization 1 chain was assembled. The other polarization was matched with a WR10 load at the OMT output.

The aim of this pre-integration was to identify criticalities and to permit to test a cartridge configuration as close as possible to the nominal one, to demonstrate the cool-down capabilities [RD4] with amplifiers inside. The pol 1 was equipped with the two INAF/JPL amplifiers mounted after the INAF feed horn and INAF OMT. In between the OMT and the amplifiers, a

straight section of WR10 waveguide was inserted. After the amplifiers, a waveguide routing was also mounted. For the 15K stage the waveguide routing was similar to the baseline, while for the other part the SS waveguide and the two transformer were substituted by a waveguide assembly based on WR10 sections present in the Cryowaves laboratory.

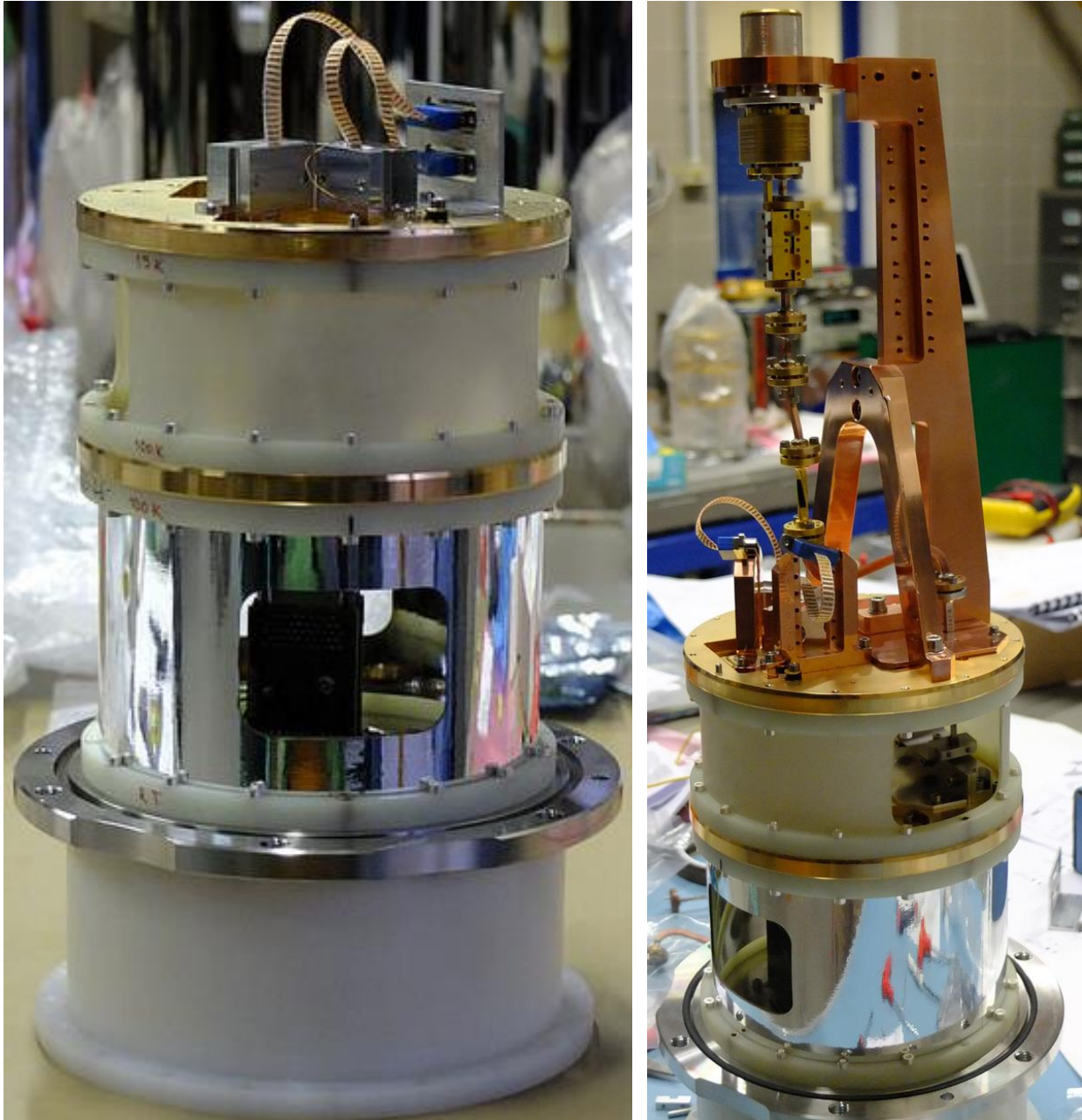

Figure 24. Pre-integration of the cartridge. Left: cartridge body Assembly for Step one. Right: cartridge assembly for Step two.

17.2 Integration of band 2+3

The integration in nominal configuration with "variant 3" started on 10 January 2017 and ended on 11 January 2017 when cool down of the cartridge started. The integration was performed in the following configuration (from 300K to 15 K stage) according to the ALMA standard definition of polarization.

Table 4. Configuration of the Variant 3 as integrated for cryogenic tests from 300K to 15K (from top to down)

Polarization 0	Polarization 1
FEEDTHROUGH	FEEDTHROUGH
WR10-H3-SN01	WR10-H3-SN02
A-165950-SN201	A-165950-SN202
WR15-SS-SN01	WR15-SS-SN02
A-165950-SN204	A-165950-SN203
WR10-H4-SN01	WR10-H4-SN02
TWIST 10-1790Au	TWIST 10-1790Au
WR10-0-3-3	WR10-T3
WR10-T0	WR10-T1
UMAN 0055-002C B23-2X30-V1 (75%) S/N WP26 B07RCM240	LNF LNC65 115WA SN065Z
	WR10-T2
UMAN 0055-002C B23-2X30-V1 (75%) S/N WP26 B09RCM730	LNF LNC65 115WA SN031Z
	WR10-1-3-R
OMT INAF	
FEEDHORN INAF	

The 'as run' assembly detailed procedure is reported in [RD9]. The procedure started to assemble the cartridge from the 300K plate and proceed to grow the cartridge from bottom to top. The WR10-Assembly was integrated without the WR10-H-4 section (see Figure 25) and both assemblies were inserted from the 110K flange through the rectangular holes. The combination of transformers and WR15 SS-waveguides was chosen during RF tests at INAF/OAA (see [RD3]) resulting in the combinations as follows (see also Table 4): [A-165950-SN203]+[WR15-SS-SN02]+[A-165950-SN202] and [A-165950-SN204]+[WR15-SS-SN01]+[A-165950-SN201].

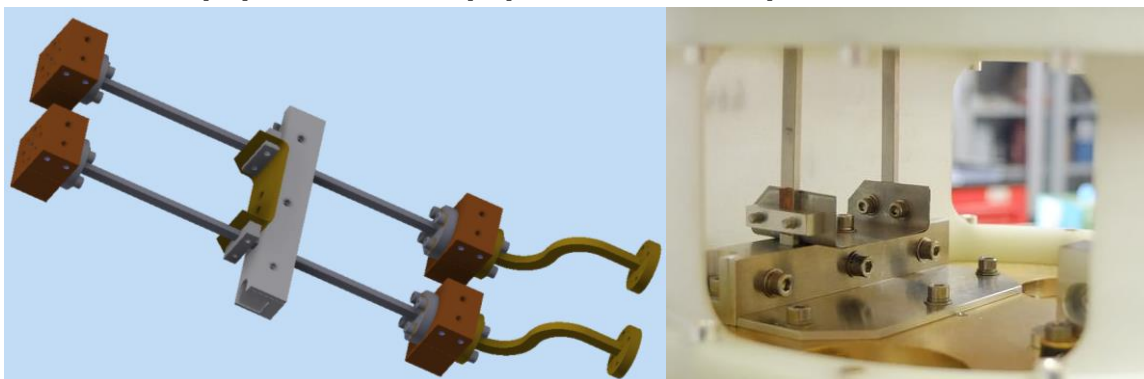

Figure 25. Right: sketch of the WR10-Assembly setup to be integrated in the cartridge. The curved waveguide section are those to be attached to the feed through on the 300K

side. Left: close view of the SS-waveguides as mounted on the 110K flange together with the heat sink.

This combination permitted to avoid resonances due to trapped modes, and was the best configuration in terms of attenuation balance. Also the Band 9 harness was inserted through the 110K flange and then fixed with the heatsink. After that, the 15K flange was mounted together with the heatsinks for harness and connectors (Figure 26).

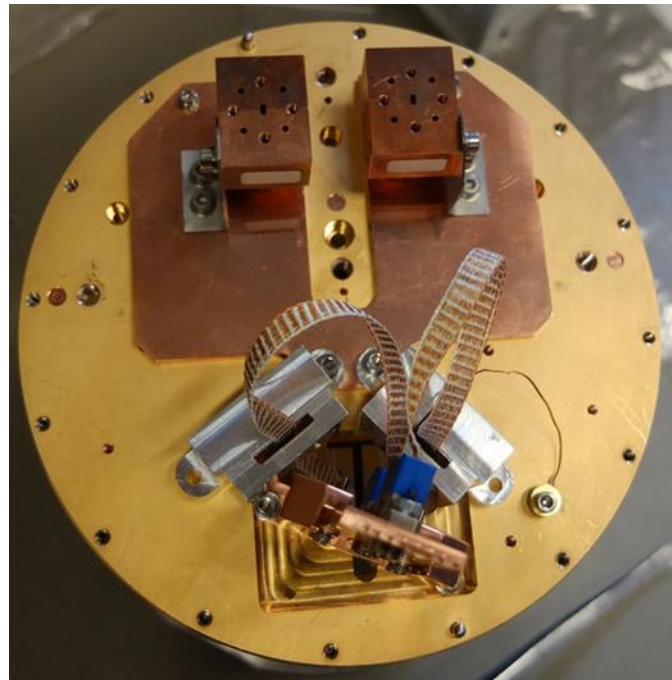

Figure 26. 15K stage flange with the two WR15-WR10 transformers (upper), the Band 9 harness with dedicated heatsinks, and the connector heatsink. On the right the temperature probe on the flange is visible

The cold assembly was integrated as in Figure 27. For polarization 1 the WR10-1-3-R was mounted just after the OMT to facilitate the mounting of the LNF amplifiers. In the baseline configuration (see Figure 28) the WR10-T1 was foreseen to be attached after the OMT.

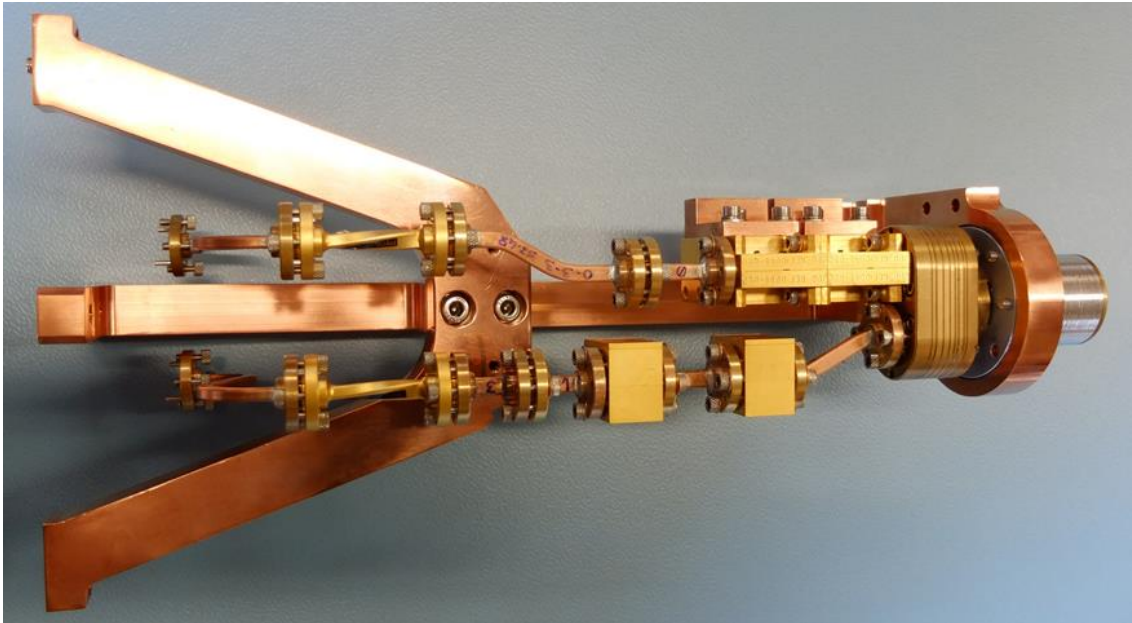

Figure 27. Configuration of the cold assembly together with feed, OMT, amplifiers and waveguides routing up to the WR15-WR10 transition. After the OMT, on pol 1, the WR10-1-3-R section was mounted in order to facilitate the integration of the LNF amplifiers.

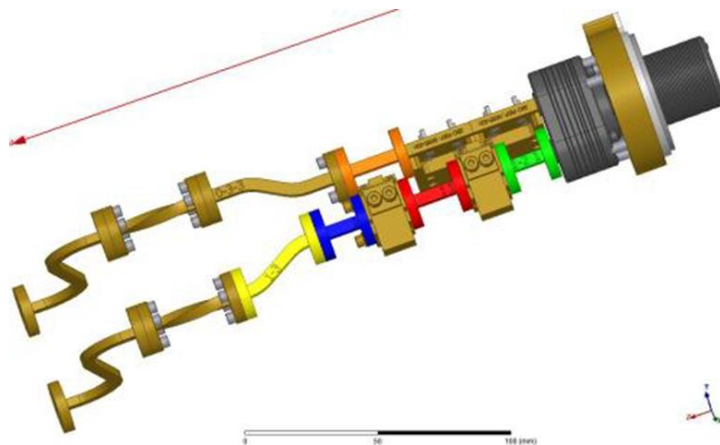

Figure 28. Foreseen mounting configuration for Varian 3 and two UMAN amplifiers on Pol 0 and 2 LNF on Pol 1. The WR10-T1 section is in green. The WR10-T0 section is in orange. The WR10-T3 section is in blue. The WR10-T2 section is in red. The WR10-1-3-R section is in yellow.

The integration was ended resulting in the cartridge reported in Figure 29.



Figure 29. The Band 2+3 (67-116 GHz) Variant 3 as integrated and ready to be inserted into the ESO NAOJ cryostat for cryogenic tests.

To connect the down converter breadboard to the CCA without using the ALMA standard interface, we used to screw output waveguides using two out of four screws on each WG feed through.