



<b>Publication Year</b>	2004
<b>Acceptance in OA @INAF</b>	2023-02-15T16:14:28Z
<b>Title</b>	SWEPT SOURCE TEST: COUPLING MEASUREMENTS REPORT
<b>Authors</b>	VILLA, Fabrizio
<b>Handle</b>	<a href="http://hdl.handle.net/20.500.12386/33502">http://hdl.handle.net/20.500.12386/33502</a>
<b>Number</b>	PL-LFI-PST-TN-058



**TITLE:**

## SWEPT SOURCE TEST: COUPLING MEASUREMENTS REPORT



**DOC. TYPE:** TECHNICAL NOTE

**PROJECT REF.:** PL-LFI-PST-TN-058

**PAGE:** I of IV, 11

**ISSUE/REV.:** 1.0

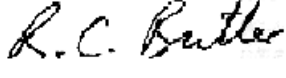
**DATE:** October 2004

Prepared by	F. VILLA LFI Project System Team	Date: October 5 <sup>th</sup> , 2004 Signature: 
Agreed by	C. BUTLER LFI Program Manager	Date: October 5 <sup>th</sup> , 2004 Signature: 
Approved by	N. MANDOLESI LFI Principal Investigator	Date: October 5 <sup>th</sup> , 2004 Signature: 







---

## TABLE OF CONTENTS

<b>1</b>	<b>INTRODUCTION AND SCOPE .....</b>	<b>1</b>
<b>2</b>	<b>APPLICABLE DOCUMENTS .....</b>	<b>2</b>
<b>3</b>	<b>REFERENCE DOCUMENTS.....</b>	<b>2</b>
3.1	SKY LOAD.....	3
3.2	SKY HORN.....	4
<b>4</b>	<b>CALIBRATION AND DYNAMIC RANGE.....</b>	<b>6</b>
<b>5</b>	<b>MEASUREMENTS RESULT .....</b>	<b>8</b>
<b>6</b>	<b>CONCLUSIONS.....</b>	<b>11</b>



## **1 INTRODUCTION AND SCOPE**

This technical note reports the measurements performed at IASF – Bologna on 29<sup>th</sup> of Sept, regarding the coupling between the truncated waveguide and the sky horn in the RCA Swept Source Test setup (see [AD 2]). These measurements have been required in order to:

- Verify the coupling level with respect to the measurements performed at ESTEC (see [RD 1])
- Investigate any source of systematics related to the coupling which may limits the RCA swept source measurement
- Validate experimentally the assumption has been used in [AD 2] related to the coupling factor.



## **2 APPLICABLE DOCUMENTS**

- [AD 1] M. Bersanelli, *LFI Calibration Plan*, PL-LFI-PST-PL-008, Issue/Rev. 1.0, July 2003  
[AD 2] F. Villa, *RCA Swept Source Measurement Setup*, Draft to be configured.

## **3 REFERENCE DOCUMENTS**

- [RD 1] J. Marti-Canales and J. Gromke, *Measurements of mutual coupling between a feed-horn and an open-ended waveguide*, SCI-PT30317, August 2004.  
[RD 2] A. Simonetto, N. Sabatini, V. Muzzini, et al. , *Tests On 30 Ghz Ebb Omt (Laben Design) And Feedhorn (Caismi Design)*, PL-LFI-PST-TN-024, June 2001  
[RD 3] F. Villa, *Summary of the EBB 30 GHz Feed Horn measured performances*, PL-LFI-PST-TN-018, March 2001  
[RD 4] F. Cuttaia, L. Terenzi, L. Valenziano, *Planck-LFI 30/ 44 GHz Sky load Implementation*, PL-PLF-PST-TN-051 Issue/Rev. 1.0, May 2004

### MEASUREMENT SETUP

The setup is a standard measurement setup for a 2 port device (see figure upper scheme) measurement performed with a scalar network analyser at IASF – Bologna. The Device Under Test is the composed by the *sky horn – Truncated waveguide* system seeing the *sky load* (Figure 1 lower scheme).

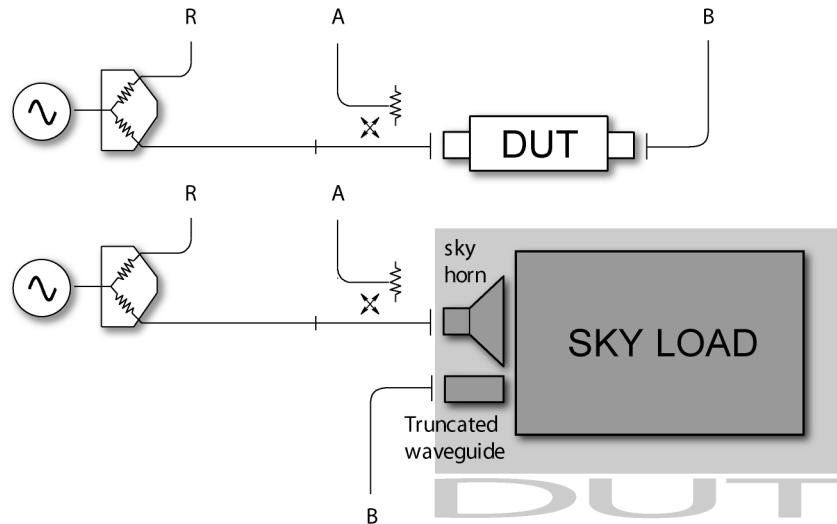

Figure 1: Schematic view of the measurement setup

### 3.1 SKY LOAD

The sky load used here is not the sky load will be integrated in the LFI RCA cryo chamber but is similar. Internal dimensions are the same and on the bottom part two rectangular sheets of pyramids have been inserted to simulate the actual sky load.

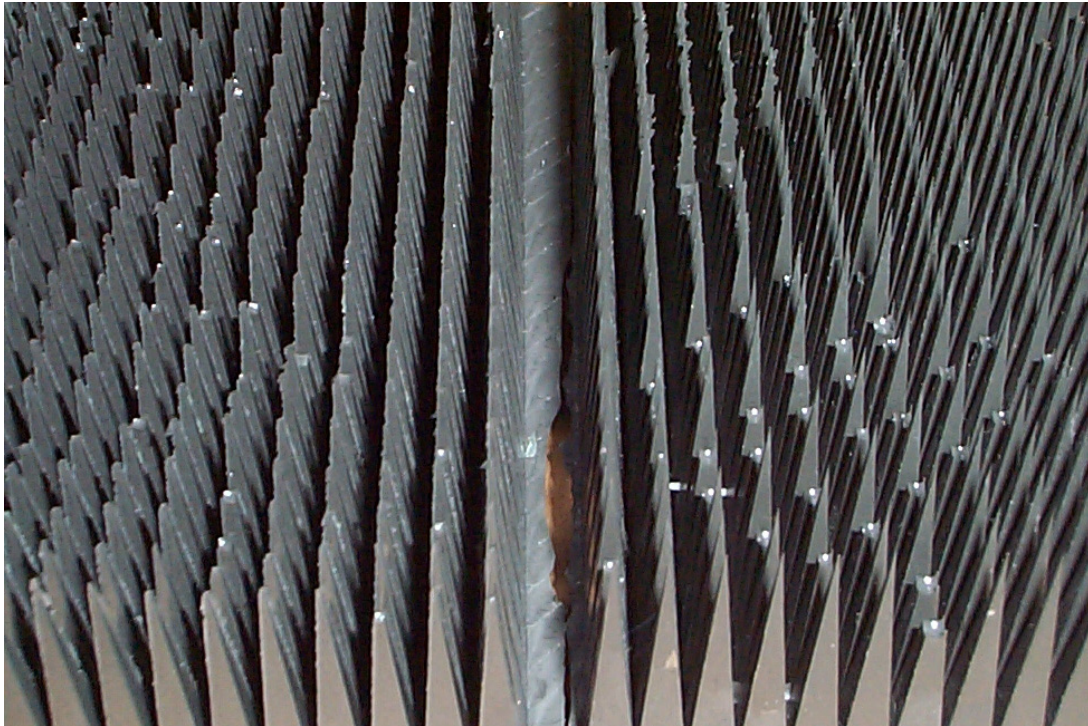

Figure 2: Sky load used during this tests.





Some pyramids are broken as readily seen in Figure 3. However it has been verified that this problem does not have impact on the expected load performances. It is stressed that the scope of such of measurements is to understand if there are some systematics not under control and it is not to fully characterize the sky load and the swept source measurement setup.



*Figure 3: Closed view of the sheets of pyramids. Some of them are broken but without impact on the measurement goal.*

### 3.2 SKY HORN

The sky horn is the LFI 30 GHz EBB. Its performances are reported in **Errore. L'origine riferimento non è stata trovata.** and [RD 3]. This horn design is similar to the Flight Model. The corrugation profile is the same. The circular waveguide straight section and the external profile are not.



*Figure 4 Sky horn. This horn is the LFI EBB horn connected to the circular / rectangular waveguide transition.*



Firstly, the return loss of the horn connected to the circular/rectangular waveguide adapter has been performed both with the horn radiating in the lab and the horn radiating into the *sky load*. Results are reported in Figure 5.

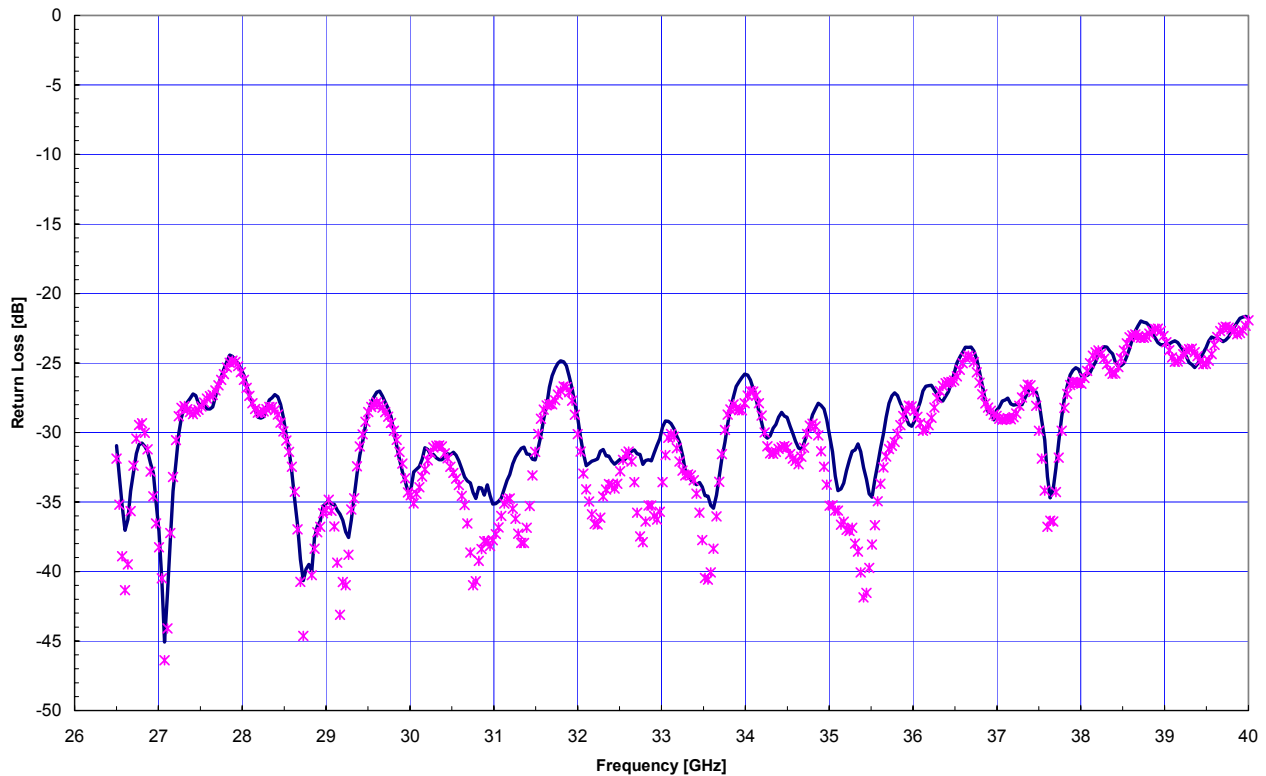

*Figure 5: Return loss of the Sky horn and its adapter radiating on free space (solid line) and on the sky load (asterisks)*

To check mismatch due to misalignment errors, the return loss has been measured also in a exaggerated condition i.e. with the axis of the sky load inclined at about 20 degrees w.r.t. the horn axis. The resulting return loss remains below  $-20$  dB, even with an high ripple, as shown in Figure 6. As a conclusion, the return loss does not affect significantly the coupling measurement.

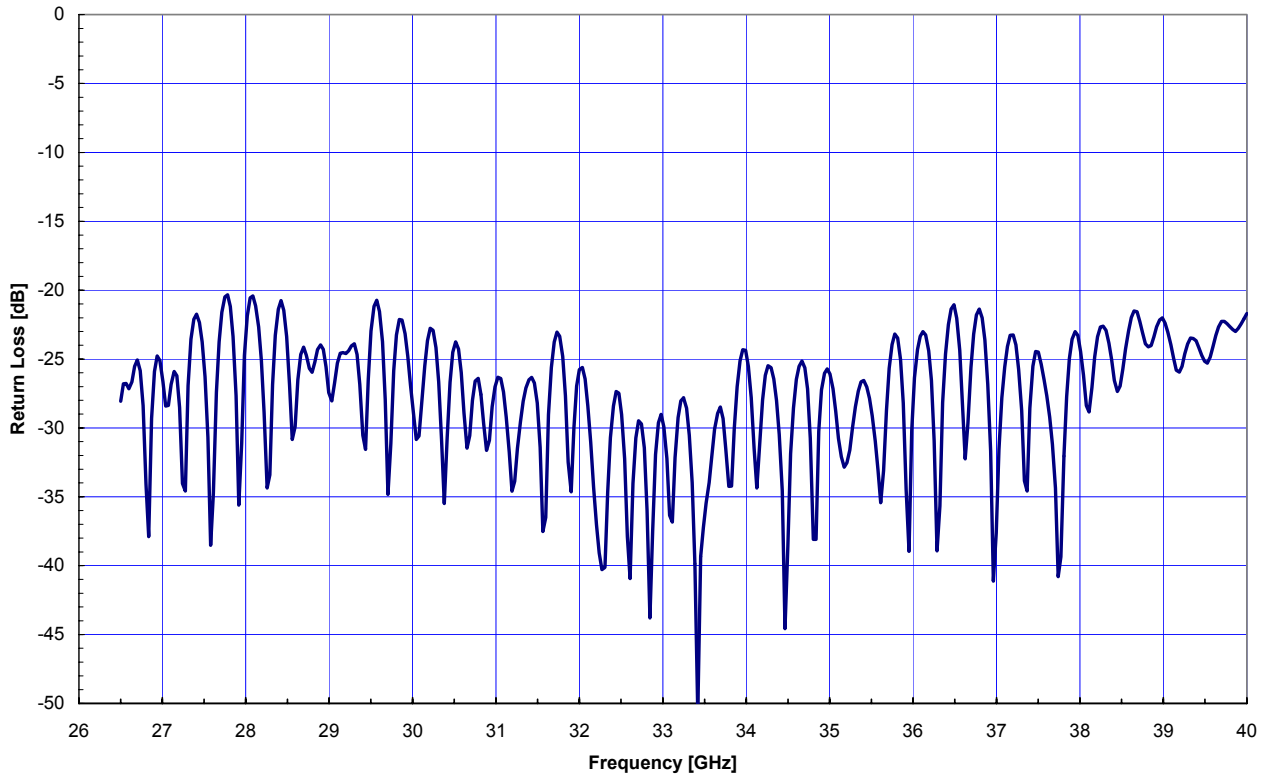

Figure 6: Return loss of the Sky horn and its transition radiating on the sky load. In this case the sky load as been tilted of about 20 degrees w.r.t. horn axis to see the effect of an exaggerated misalignment.

#### 4 CALIBRATION AND DYNAMIC RANGE

Calibration of the port A ( $S_{11}$ ) has been done with an aluminium foil acting as a short at the Horn (including circular to rectangular adapter) / Directional Coupler interface. What has not calibrated is the effect of the corrugated horn (including the adapter) mismatch and its attenuation. However it's negligible. Calibration of the port B ( $S_{21}$ ) has been done connecting the port B, which is the truncated waveguide, directly at the directional coupler interface.

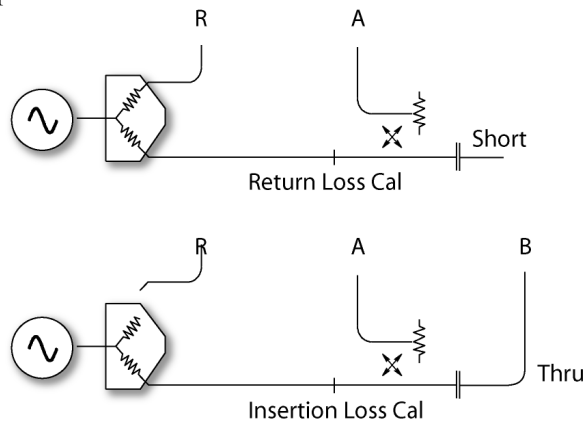
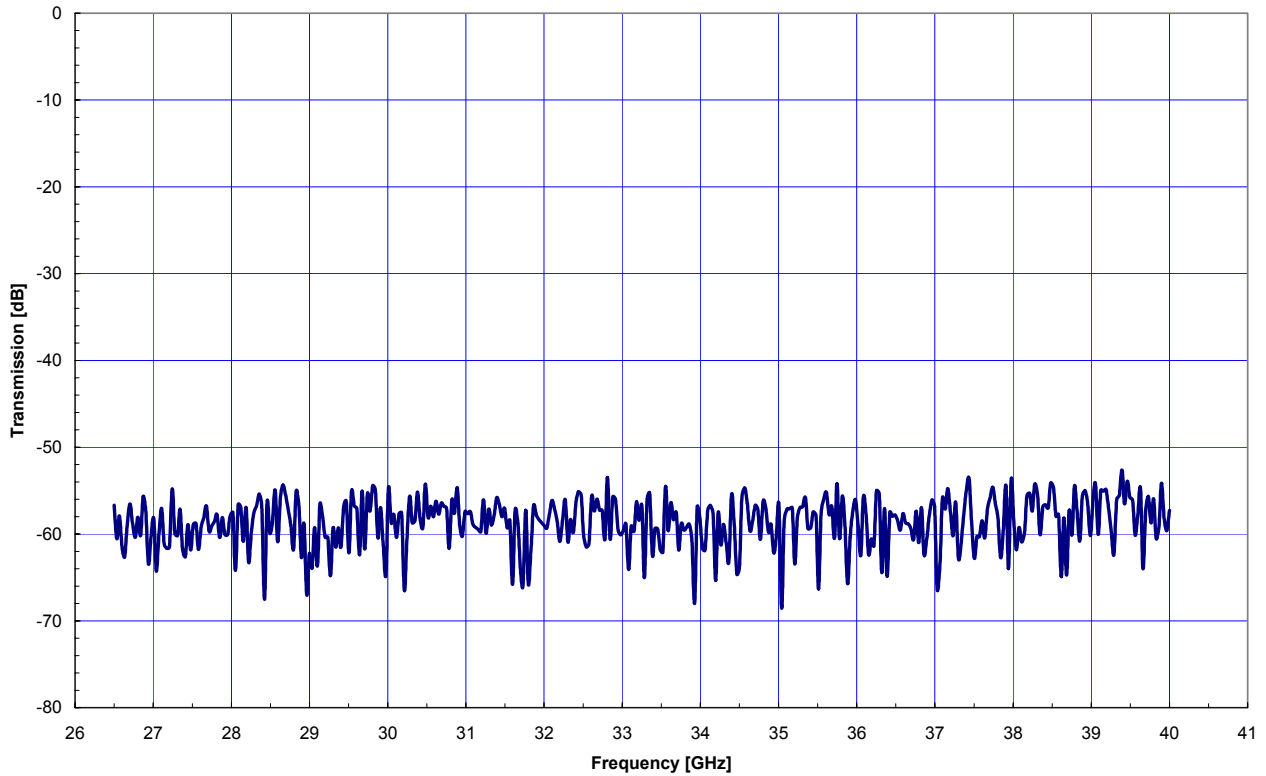

Figure 7: 2-port scalar standard calibration concept



The noise floor of the entire measurement setup has been derived by putting a good absorber in front of the horn aperture. A dynamic range of 60 dB has been reached.



*Figure 8: Noise level. No average has been applied.*

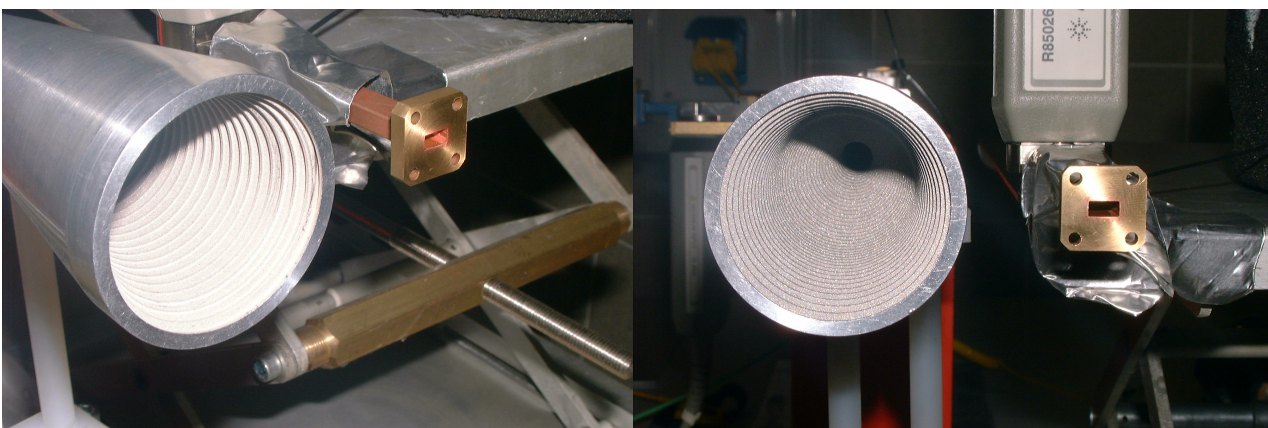

*Figure 9: Pictures of the measurement setup.*



## 5 MEASUREMENTS RESULT

The corrugated horn has been used as transmitter. Below the result of the coupling measurements have been reported. The sequence of the measurements has been the following (see also Figure 10):

- (1) Coupling measurement in free space condition: the horn is radiating into the lab. No absorber has been used in front of the horn and the waveguide
- (2) Coupling measurement with the horn and waveguide seeing the sky load centred between them.
- (3) Coupling measurement with the horn and waveguide seeing the sky load centred at the horn
- (4) Coupling measurement with the horn and waveguide seeing the sky load centred at the horn and metallic plate covering the load (cover plate)

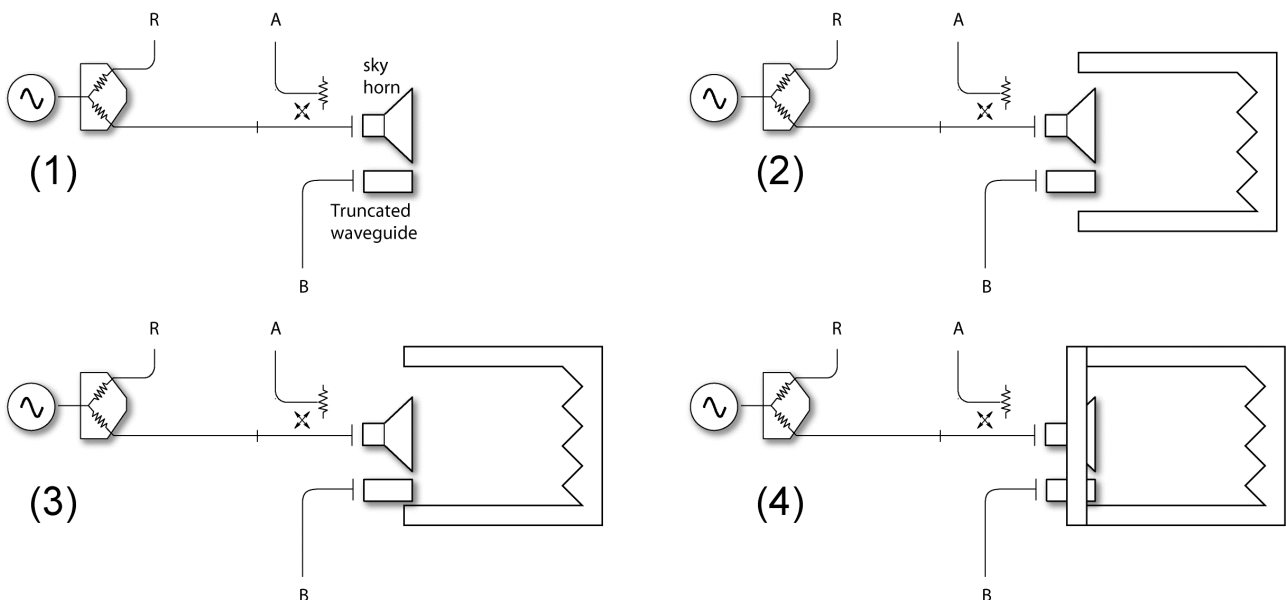

*Figure 10: four configurations adopted during the measurements.*

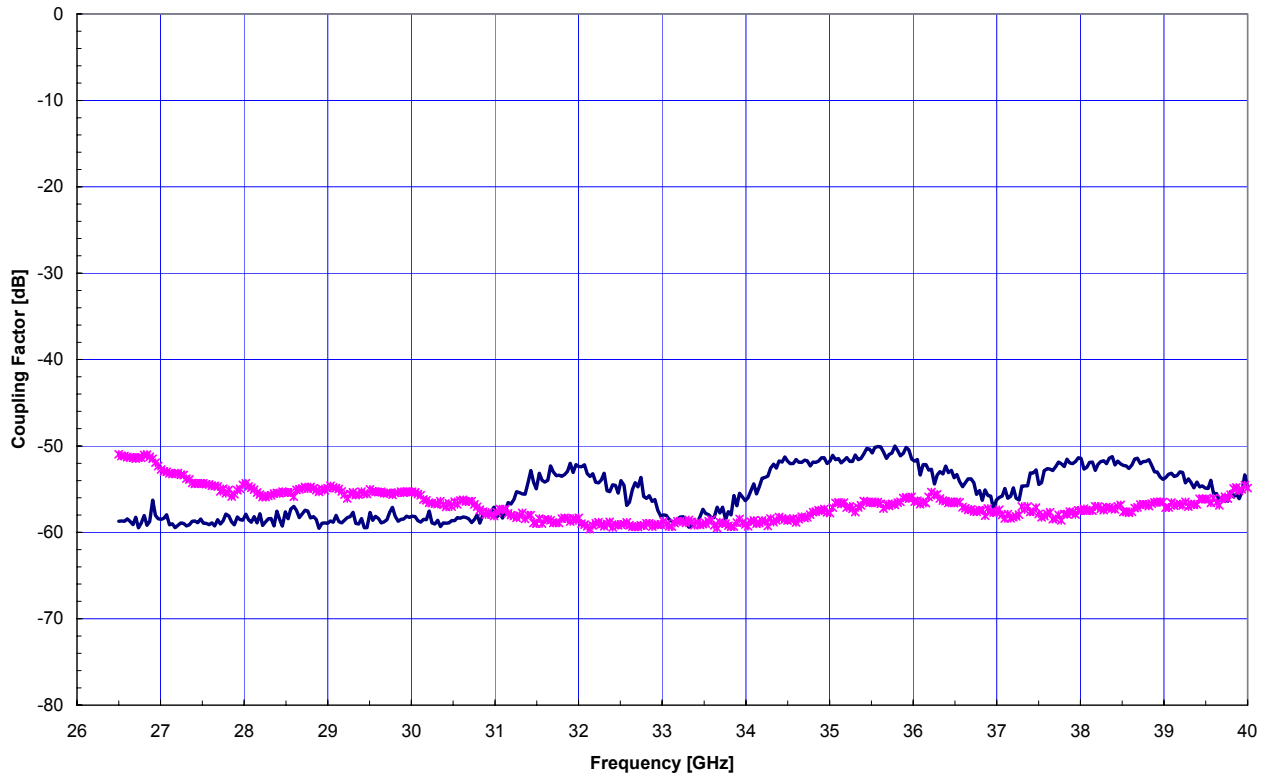

Figure 11: Solid line: EBB Horn in transmitted mode, waveguide in receiving mode both seeing the surrounding Lab; measurements taken by averaging 64 points (see (1) in the text). Asterisks: EBB Horn in transmitted mode, waveguide in receiving mode both seeing the sky load centred on the Horn/WG system . Measurements taken by averaging 64 points (see (2) in the text).

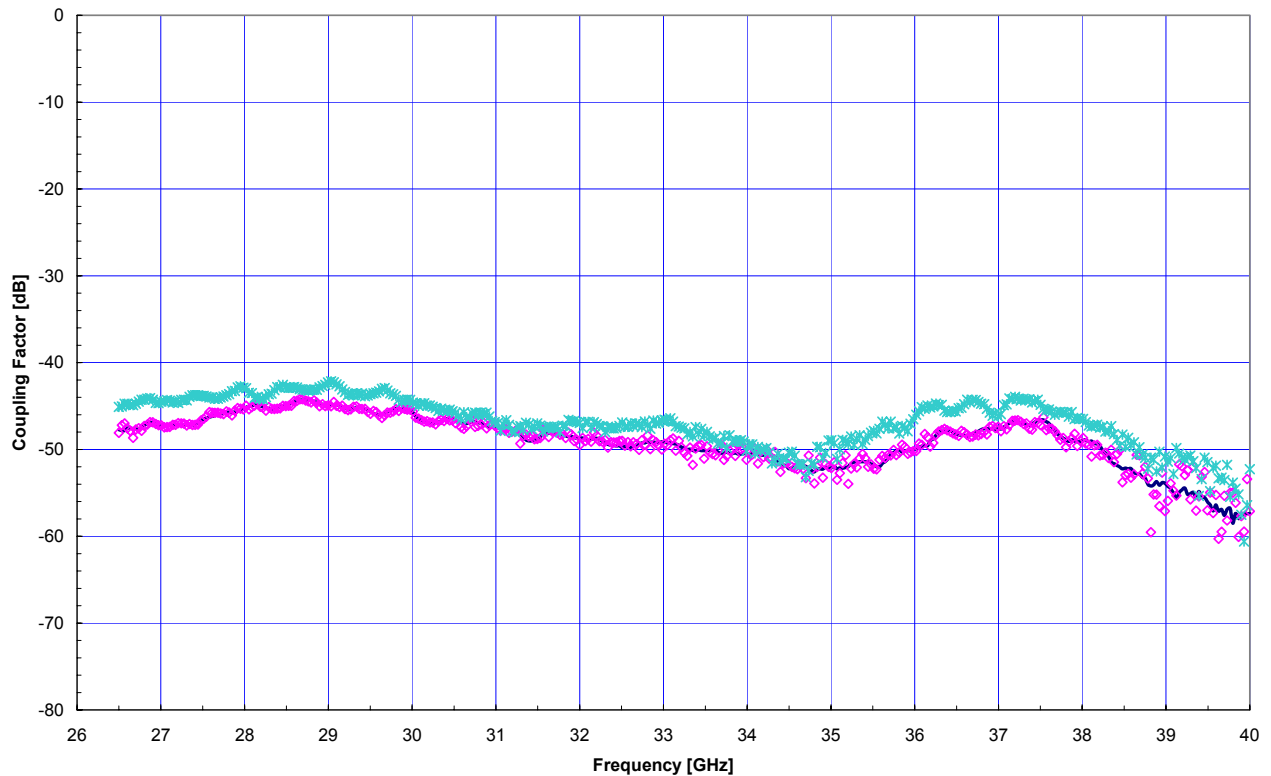

Figure 12: Solid line: EBB Horn in transmitted mode, waveguide in receiving mode both seeing the sky load centred at the horn; measurements taken by averaging 64 points (see (3) in the text). Squares: the same but without averaging. Asterisks: EBB Horn in transmitted mode, waveguide in receiving mode both seeing the sky load centred on the Horn/WG system and covered with a metallic cover plate; measurements taken by averaging 64 points (see (4) in the text).

At the end of the tests, calibration has been checked again. The curves are reported in *Figure 13* showing a calibration stability well below  $\pm 0.1$  dB for the S11 parameter (return loss) and better than  $\pm 0.3$  dB for the S21 parameter (coupling).

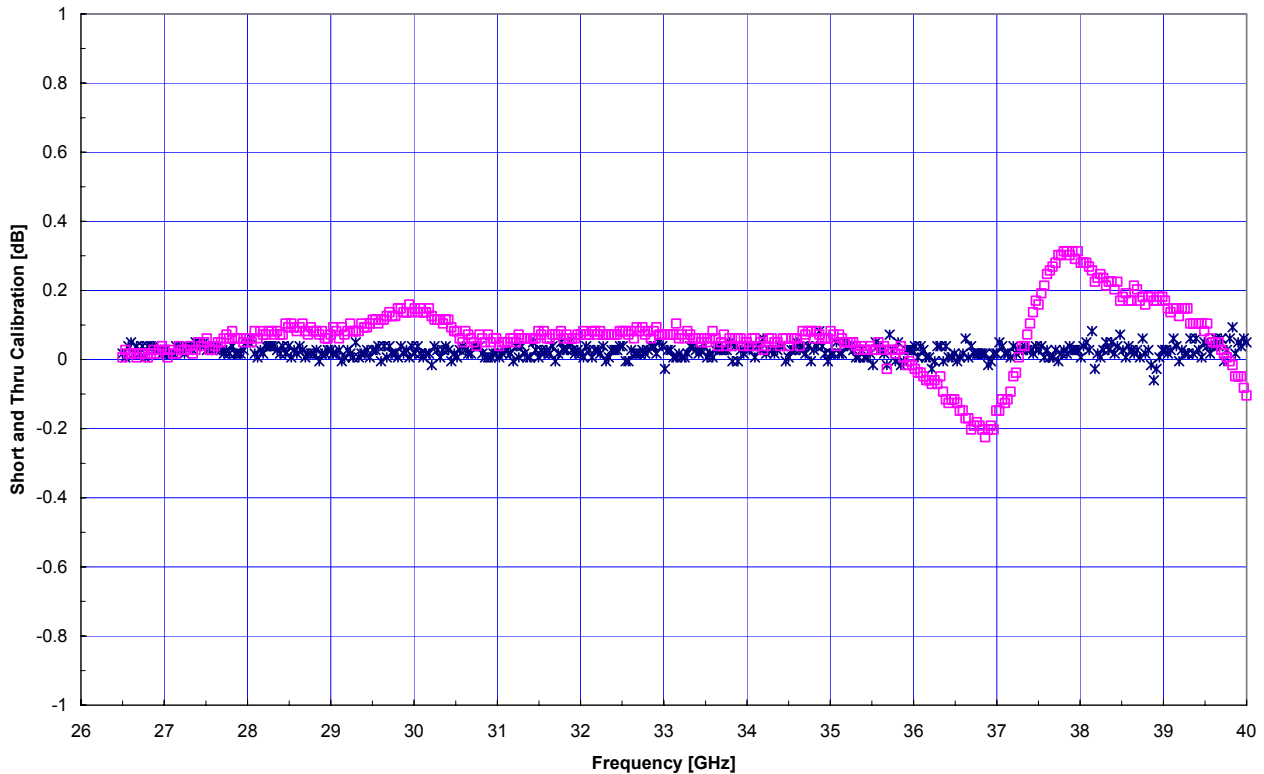

Figure 13: Calibration check. Asterisks: Calibration of the S11 parameter. Squares: calibration of the S21 parameter.

## 6 CONCLUSIONS

Based on these measurements some conclusion could be outlined:

- a) These measurements do not show major criticalities associated to the coupling factor between the waveguide and the horn.
- b) The configuration (2), i.e. with the sky load centred on the horn/WG system, is the best one for coupling
- c) The coupling in the configuration (3) and (4) is 5 dB worst approximately. However, with the real sky load the bottom part is completed covered by pyramids and the cover plate by eccosorb sheet.
- d) Finally, from these measurements, it seems that a reasonable number for the coupling factor is between 40 and 50 dB depending on the exact configuration. However, measurements will be performed again with the real RCA sky load and the FM horn, hopefully with a vector network analyzer.