



Publication Year	2022
Acceptance in OA @INAF	2023-06-06T14:57:07Z
Title	The Software Architecture and development approach for the ASTRI Mini-Array gamma-ray air-Cherenkov experiment at the Observatorio del Teide
Authors	BULGARELLI, ANDREA; LUCARELLI, Fabrizio; Tosti, G.; CONFORTI, Vito; PARMIGGIANI, Nicolo'; et al.
DOI	10.1117/12.2629164
Handle	http://hdl.handle.net/20.500.12386/34244
Series	PROCEEDINGS OF SPIE
Number	12189

PROCEEDINGS OF SPIE

SPIDigitalLibrary.org/conference-proceedings-of-spie

The Software Architecture and development approach for the ASTRI Mini-Array gamma-ray air-Cherenkov experiment at the Observatorio del Teide

A. Bulgarelli, F. Lucarelli, G. Tosti, V. Conforti, N. Parmiggiani, et al.

A. Bulgarelli, F. Lucarelli, G. Tosti, V. Conforti, N. Parmiggiani, J. H. Schwarz, L. A. Antonelli, L. Baroncelli, C. Bigongiari, M. Capalbi, M. Cardillo, G. A. Rodriguez Castillo, O. Catalano, A. A. Compagnino, M. Corpora, A. Costa, S. Crestan, G. Cusumano, A. D'Ai', V. Fioretti, S. Gallozzi, S. Germani, F. Gianotti, V. Giordano, A. Giuliani, P. G. Bruno, J. G. Green, A. Grillo, F. Incardona, S. Iovenitti, N. La Palombara, V. La Parola, M. Landoni, S. Lombardi, M. C. Maccarone, R. Millul, T. Mineo, D. Mollica, A. Pagliaro, G. Pareschi, V. Pastore, M. Perri, F. Pintore, P. Romano, F. Russo, P. Sangiorgi, F. G. Saturni, E. Sciacca, S. Scuderi, A. Tacchini, V. Testa, M. Trifoglio, A. Tutone, S. Vercellone, "The Software Architecture and development approach for the ASTRI Mini-Array gamma-ray air-Cherenkov experiment at the Observatorio del Teide," Proc. SPIE 12189, Software and Cyberinfrastructure for Astronomy VII, 121890D (29 August 2022); doi: 10.1117/12.2629164

SPIE.

Event: SPIE Astronomical Telescopes + Instrumentation, 2022, Montréal, Québec, Canada

The Software Architecture and development approach for the ASTRI Mini-Array gamma-ray air-Cherenkov experiment at the Observatorio del Teide

A. Bulgarelli^a, F. Lucarelli^{b,c}, G. Tosti^d, V. Conforti^a, N. Parmiggiani^a, J. H. Schwarz^e, L. A. Antonelli^b, L. Baroncelli^a, C. Bigongiari^b, M. Capalbif, M. Cardillo^g, G. A. Rodriguez Castillo^f, O. Catalano^f, A. A. Compagnino^f, M. Corpora^f, A. Costa^h, S. Crestaniⁱ, G. Cusumano^f, A. D'Ai^f, V. Fioretti^a, S. Gallozzi^b, S. Germani^e, F. Gianotti^a, V. Giordano^h, A. Giulianiⁱ, P. G. Bruno^h, J. G. Green^z, A. Grillo^h, F. Incardona^h, S. Iovenitti^e, N. La Palombaraⁱ, V. La Parola^f, M. Landoni^e, S. Lombardi^b, M. C. Maccarone^f, R. Millul^e, T. Mineo^f, D. Mollica^f, A. Pagliaro^f, G. Pareschi^e, V. Pastore^a, M. Perri^b, F. Pintore^f, P. Romano^e, F. Russo^a, P. Sangiorgi^f, F. G. Saturni^b, E. Sciacca^h, S. Scuderiⁱ, A. Tacchini^a, V. Testa^b, M. Trifoglio^a, A. Tutone^b, S. Vercellone^e, and for the ASTRI Project^j

^aINAF/OAS Bologna, Via P. Gobetti 93/3, I-40129 Bologna, Italy.

^bINAF/OAR Roma, Via di Frascati 33, I-00078 Monte Porzio Catone, Roma, Italy.

^cASI/SSDC Roma, Via del Politecnico snc, I-00133 Roma, Italy.

^dUniversità degli Studi di Perugia, Dip.to di Fisica e Geologia, Via A. Pascoli, I-06123 Perugia, Italy

^eINAF/OA Brera, via Brera 28, I-20121 Milano, Italy.

^fINAF/IASF Palermo, Via Ugo La Malfa 153, I-90146 Palermo, Italy.

^gINAF/IAPS Roma, via del Fosso del Cavaliere 100, I-00133 Roma, Italy.

^hINAF/OACT Catania, via Santa Sofia 78, I-95123 Catania, Italy.

ⁱINAF/IASF Milano, Via Alfonso Corti 12, I-20133 Milano, Italy.

^j<http://www.astri.inaf.it/en/library/>

ABSTRACT

The ASTRI Mini-Array is an international collaboration led by the Italian National Institute for Astrophysics (INAF) and devoted to the imaging of atmospheric Cherenkov light for very-high gamma-ray astronomy. The project is deploying an array of 9 telescopes sensitive above 1 TeV. In this contribution, we present the architecture of the software that covers the entire life cycle of the observatory, from scheduling to remote operations and data dissemination. The high-speed networking connection available between the observatory site, at the Canary Islands, and the Data Center in Rome allows for ready data availability for stereo triggering and data processing.

Keywords: ASTRI Mini-Array, Cherenkov telescopes, Software Architecture, Software Engineering

1. INTRODUCTION

The ASTRI Mini-Array^{1,2} is a ground-based project lead by INAF to construct, deploy and operate a set of nine identical dual-mirror Cherenkov gamma-ray telescopes, and several other auxiliary equipment and infrastructures. The ASTRI Mini-Array scientific objective is to exploit the imaging atmospheric Cherenkov technique to measure the energy, direction and arrival time of gamma-ray photons arriving at the Earth from astrophysical sources. In the almost unexplored energy range 1-300 TeV this technique requires an array of optical telescopes (~ 4 m in diameter) at a site located at an altitude greater than 2000 m. The telescopes have reflecting mirrors

Further author information: (Send correspondence to A. Bulgarelli)

A. Bulgarelli: E-mail: andrea.bulgarelli@inaf.it

Software and Cyberinfrastructure for Astronomy VII, edited by Jorge Ibsen,
Gianluca Chiozzi, Proc. of SPIE Vol. 12189, 121890D · © 2022 SPIE
0277-786X · doi: 10.1117/12.2629164

Proc. of SPIE Vol. 12189 121890D-1

focusing the Cherenkov UV-optical light produced by atmospheric particle cascades (air-showers), initiated by the primary gamma-ray photons entering the atmosphere, onto ultra-fast (nanosecond timescale) cameras. Most of the collected data will come from the large number of charged primary cosmic-ray initiated air-showers, which will also be recorded, then appropriate data analysis methods will be employed to reduce the level of this background and allow an efficient detection of gamma-rays coming from astrophysical sources.

Besides the gamma-ray scientific program, the ASTRI Mini-Array will also perform stellar Hambury-Brown intensity interferometry and direct measurements of cosmic rays. Stellar Hambury-Brown intensity interferometry is possible because each telescope of the ASTRI Mini-Array will be equipped with an intensity interferometry module. The ASTRI Mini-Array layout with its very long baselines (hundreds of meters), will allow angular resolutions down to 50 micro-arcsec, making possible to reveal details on the surface of bright stars and of their surrounding environment and to open new frontiers in some of the major topics in stellar astrophysics. The direct measurements of cosmic rays is also possible because 99% of the observable component of the Cherenkov light is hadronic in nature. Even if the main challenge in detecting gamma-rays is to distinguish them from the much higher background of hadronic cosmic rays, this background, recorded during normal gamma-ray observations, will be used to perform direct measurements and detailed studies of the cosmic rays themselves.

The ASTRI Mini-Array telescopes, including the Cherenkov Camera,³ are an updated version of the ASTRI-Horn Cherenkov Telescope⁴ operating at Serra La Nave (Catania, Italy) on Mount Etna. The software developed by INAF for the ASTRI-Horn telescope, including development, testing and production environments, is partially reused also in the ASTRI Mini-Array context.

The **ASTRI Mini-Array Software System** (MASS) is under development by INAF teams and other Italian research institutions (including other public research institutions, such as the University of Perugia and INFN), external institutes and industrial partners. INAF is in charge of software management and coordination, requirements specifications, top-level architecture definition, integration, verification, and the development of the most significant part of the software subsystems. MASS manages observing projects, observation handling, remote array control and monitoring, data acquisition, archiving, processing and simulations of the Cherenkov and Intensity Interferometry observations, including science tools for the scientific exploitation of the ASTRI Mini-Array data.

1.1 The ASTRI Mini-Array system

The ASTRI Mini-Array system^{1,2} is geographically distributed in the following main sites:

1. The **Array Observing Site (AOS)** at Observatorio del Teide (operated by the Instituto de Astrofísica de Canarias, IAC), where the nine telescopes and all Observing Site Subsystems are under installation. The AOS includes a Data Center for computing and networking resources.
2. **Array Operation Centers (AOCs)** include control rooms located remotely at the IAC facilities in La Laguna (Tenerife), at different remote INAF locations in Italy, and one at the Teide site to be used during the installation and commissioning phase. Control rooms will allow the Operator to supervise and carry out the scheduled observations and calibrations during the night, while the astronomer on-duty (AoD) will support and supervise the observations.
3. The **ASTRI Data Center** in Rome, for the data processing, simulation, archiving and science user support.

MASS runs at the Array Observing Site (the on-site software) and in the ASTRI Data Center in Rome (the off-site software). The array Operator will be able to connect remotely to on-site software from AOCs.

The on-site software must control and/or monitor the following hardware systems installed at the Array Observing Site:

1. Observing subsystems:

- (a) The **Array System**, is composed of nine telescopes with their assemblies, including the two main scientific instruments permanently mounted on each telescope: the Cherenkov Camera and the Stellar Intensity Interferometry Instrument.^{5,6} In addition an Optical Camera, mounted on each telescope, will be used for the calibration and maintenance activities. Each telescope has a Pointing Monitoring Camera, installed on the rear of the secondary mirror (M2) support structure to obtain astrometric calibrated field-of-view (FoV) of the region pointed by the telescope.⁷
- (b) **Atmosphere Characterisation system**: (i) LIDAR (LIght Detection And Ranging) to study the atmospheric composition, structure, clouds and aerosols through the measurement of the atmospheric extinction profile; (ii) SQM (Sky Quality Meter): measures the brightness of the night sky in magnitudes per square arcsecond. Two SQM are mounted on two telescopes, plus one with the All-Sky camera, an instrument that monitors the cloud coverage; (iii) UVSIPM:⁸ a light detector that measures the intensity of electromagnetic radiation in the 300–900 nm wavelength range. The analysis of the UVSIPM data will be used mainly to evaluate the level of the diffuse night sky background (NSB).
- (c) **Array Calibration system**, made only by one device, the Illuminator, a portable ground-base device determines the response efficiency. The Illuminator has been designed to uniformly illuminate the telescope's aperture, either with a pulsed or continuous reference photon flux. The NIST-calibrated photodiode monitors the absolute intensity.

2. Site service systems:

- (a) **Telescope Power Management system** including centralized uninterruptible power supply (UPS) system, to provide power to the entire ASTRI Mini-Array system;
- (b) **Information and Communication Technology (ICT) system**, the computing and networking infrastructure and all on-site and off-site system services to control and monitor the array, to archive and analyse the scientific and engineering data. The ICT also includes the time synchronization system which synchronize with a sub-ns precision the Cherenkov Cameras, in order to tag properly the Cherenkov events;
- (c) **Environmental Monitoring system**: (i) two weather stations; (ii) humidity sensors; (iii) rain sensors: for prompt detection of rain, acquired at 2 Hz; (vi) All-sky camera: monitoring cloud coverage both during daylight and night time.

3. Safety and Security system: an independent system for the protection of people and site assets.

Each hardware have a Local Control System, i.e., a hardware/software system used to switch-on/switch-off, control, configure and get the status, monitoring points and alarms of all parts of the system/assembly. The software part is called **Local Control Software (LCS)**. Each LCS could have its own **Local Engineering graphical user interface (GUI)**. LCSs are typically delivered as part of an externally contracted sub-system and then interfaced to the ASTRI software infrastructure on the basis of a specific Interface Control Documents: each LCS implements an interface to the ASTRI Mini-Array software system based on the IEC 62541 standard for the OPC Unified Architecture protocol*. It is one of the most important communication protocols for Industry 4.0 and the Internet of Things. OPC-UA allows access to machines, devices and other systems in a standardized way and enables similar and manufacturer-independent data exchange.

2. THE OBSERVING CYCLE

The ASTRI Mini-Array observing cycle is the main driver for developing the ASTRI Mini-Array software architecture. MASS is envisioned to handle the observing cycle, i.e. the end-to-end control and data flow, and the information and operations required to conduct all tasks from the time an *Observing Project* (a description of a scientific project to observe a target) is created, until the resulting data are returned and analysed.

*<https://opcfoundation.org>

A schematic representation of the global information flow is given in Fig. 1, where the main phases and related functions of the observing cycle are shown. The observing cycle is divided into the following main phases: (i) Observation preparation; (ii) Observation execution; (iii) Data Processing; (iv) Dissemination.

Observation preparation. The observing cycle initiates by submitting an Observing Project. Once the ASTRI Mini-Array Science Team has selected the Observing Project, it is turned into *Scheduling Blocks* (SBs), containing all the information required to perform the corresponding observations. SBs are divided into *Observing Blocks* (OBs), i.e. the smallest sequence of observing instructions that can be scheduled. SBs and OBs are scheduled and stored in the Archive System

Observation execution. The Central Control executes Observing Blocks, carrying out setups (with an appropriate set of configuration parameters), calibrations, and target observations necessary to ensure that the acquired data are properly calibrated and used in the construction of the final data product. Operations at the ASTRI Mini-Array observing site will be supervised remotely by the array Operator via a remote graphical user interface. MASS starts the array elements, checks the status of the array, checks environmental conditions and atmosphere characterisation (e.g. NSB level), performs array calibration, and checks observation data quality. The array Operator can also change the schedule manually, check the status of assemblies, and administer other resources. Changes in environmental conditions, atmosphere characterisation, or array status can change the kinds of observations that can be carried out; SBs are scheduled or stopped taking into current conditions.

Data Processing phase. The Data Processing produces calibrated and reconstructed data (the final event list), applying whatever corrections are necessary. Monte Carlo simulations are performed to optimise the reconstruction of the Cherenkov events. In case the results of the data processing indicate the need to modify the long-term observation plan to follow-up a particularly interesting state of a source, this is done manually.

Data Dissemination phase. Data and Science Tools are distributed for a scientific analysis of the Observing Projects. Science Tools can be used to produce images and/or spectra and detection of gamma-ray sources. High-level data and data products (event lists and Instrument Response Functions (IRFs)) are released to the ASTRI Science Team.

Storing all persistent information in the Archive System makes the system less coupled so that these phases can work independently as long as they maintain the information flow to and from the Archive.

3. MAIN REQUIREMENTS

In order to reduce overall operation cost and manpower the following top level requirements were considered for the definition of the software architecture.

1. The ASTRI Mini-Array shall be controlled and monitored by a software running on-site with the telescopes.
2. No human presence is foreseen at the site during the nights. The ASTRI Mini-Array shall be operated from the Array Operation Centers (AOCs) available from different locations, including one at the Array Observing Site. Only one AOC shall control the array, while any others shall be restricted to a read-only mode, suitable for monitoring.
3. The scientific targets shall be defined by the ASTRI Science Team based on their visibility and the priority assigned to each science program. The ASTRI Mini-Array observation plan shall be prepared and validated in advance with the help of suitable tools.
4. The Target of Opportunity (ToO) should be selected and prepared during the night and added manually to the current observation plan.
5. MASS shall be able to automatically execute the whole sequence of operations to perform an observation.
6. Only a quick-look of data at single Cherenkov Camera level shall be possible on-site by an online observation quality system.⁹
7. MASS shall be able to react to environmental critical and survival conditions in an automatic way to put the array system in safe state.

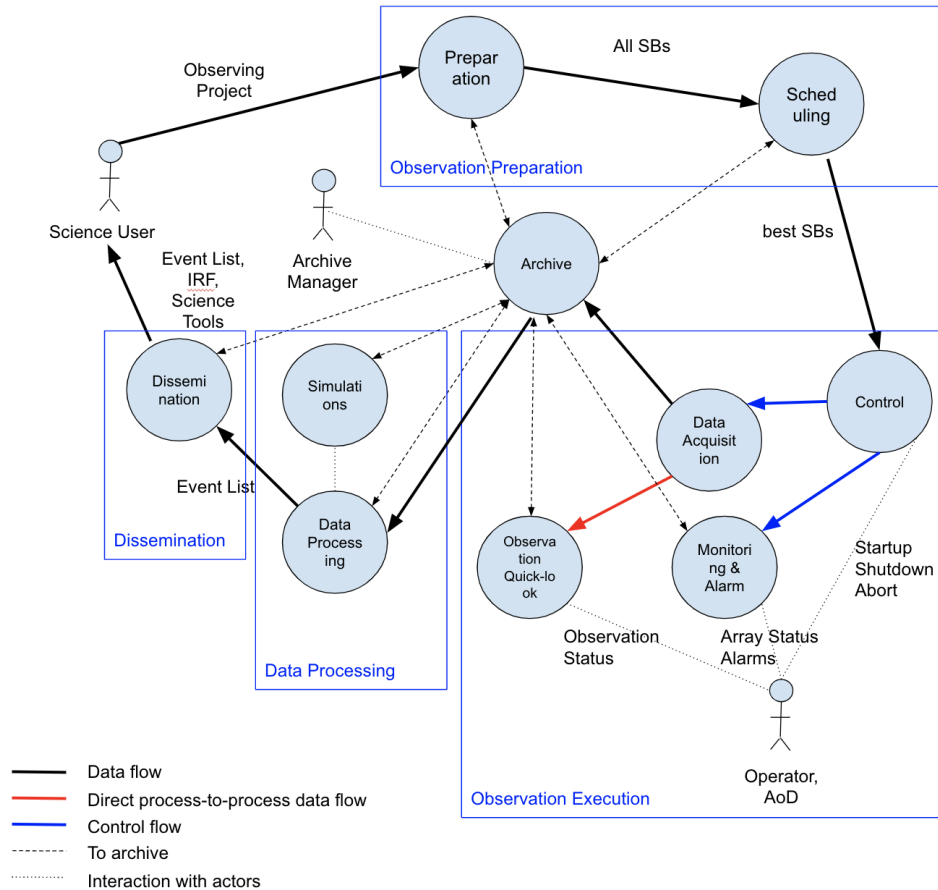

Figure 1. ASTRI Mini-Array data and information flow (schematic) with the four main phases. The outer solid black and red lines show the logical data flow, where the solid blue lines are control flow. Direct process-to-process communication is indicated with a red line. The Archive Manager is responsible for the quality and integrity of the archive. The dashed lines directed to/from the Archive indicate that a) all data is saved and can be retrieved from the Archive, and b) that the physical data flow may be handled by the Archive. A Data Processing Manager and a Data Quality Scientist in charge, respectively, of the data processing operations and of the quality of the data processing outputs, are not shown.

8. The amount of data storage installed at the observing site shall be adequate to guarantee no loss of technical and scientific data in case of lack of connection to the wide-area network. In particular, the on-site storage shall have the capability to maintain for at least 7 days: scientific RAW data; monitoring, logging and alarm data; data and data products of the online observation quality system.⁹
9. All data shall be transferred to the remote data center located in Rome (Italy) at the end of each run, where they will be permanently archived.
10. Any search for Cherenkov events detected in coincidence by more than one telescope (stereo trigger) shall be performed via software off-line at the Rome Data Center.
11. All data processing shall be carried out off-line at the Rome Data Center, including the historical analysis of monitoring and logging data.
12. All highest-level data products, associated with Observing Projects, produced by the off-line data processing shall be validated, archived, and made accessible to the ASTRI Science Team.

13. The ASTRI Science Team shall provide dedicated science tools for the scientific exploitation of the ASTRI Mini-Array data.
14. The ASTRI Mini-Array software used during operation shall be open-source, governed by the Free Software Foundation's Lesser General Public License (LGPL).

4. GENERAL SOFTWARE ARCHITECTURE

4.1 The 4+1 architectural view model and the top level software documents

The main objective of a software architecture is to present the organization of the software system, describe its structural elements and their behaviour, and compose these structures into larger subsystems. The architectural approach used by ASTRI Team is the 4+1 view architectural view model¹⁰ illustrated in Fig. 2, and consists of looking the system through different views, represented with UML diagrams: (i) *Use Case View*: A use case is a list of actions or event steps typically defining the interactions between an actor and a system to achieve a goal. The actor can be a human or other systems; (ii) *Logical/Functional View*: a functional decomposition of the system with the description of the global information flow (based on the analysis of Use Cases and Data Models); (iii) *Process View* deals with the dynamic aspect of the system; (iv) *Implementation/Development View*: represents the detailed design of the implemented system; (v) *Physical/Deployment View*: The physical view depicts the system from a system engineer's point of view. It is concerned with the topology of software components on the physical layer as well as the physical connections between these components. Physical view is more concerned with the physical layer of the system, deployment view with the allocation of computing resources on physical nodes.

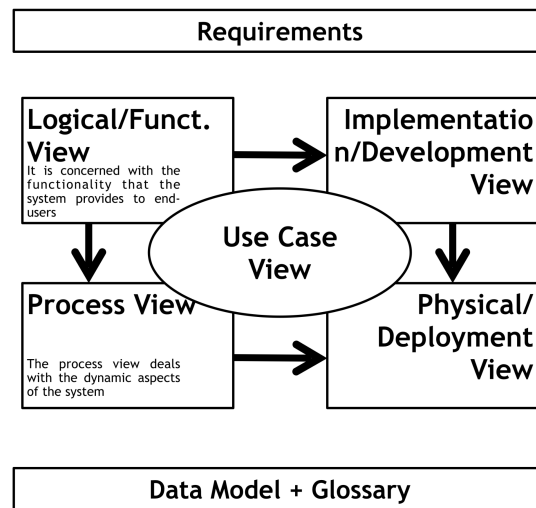

Figure 2. Illustration of the 4+1 Architectural View Model with requirements and data model and glossary to complement the information.

To define the views the INAF team developed a set of preliminary top level software documents (also called software system engineering documents), summarised in this contribution. These documents have already passed a Concept Design Review (CoDR) by a panel of external reviewers organized by INAF in June 2020. These document includes: (i) Top Level Use Case document, (ii) Top Level Software Architecture document, (iii) Top Level Data Model document, (iv) Product Breakdown Structure, (v) Glossary.

The main inputs for the definition of these documents was the ASTRI science and system requirements, the ASTRI operation concept² and the ASTRI science use cases.

The Top Level Use Cases document captures the greatest possible number of points of view during the requirements-gathering phase. This document contains observation-related use cases, that describe how to

perform observations from the proposal to the scientific exploitation of the observation from a user's point of view and the commonalities of all the science-related use cases. This category includes calibration and other technical related use cases. Actors can be humans or a software sub-system. This document covers the Use Case View of the system and is the starting point for the development of detailed Use Case Documents at sub-system level.

The main actors that interacts with the software system are the following:

1. The Science User performs observations related to the Observing Projects and analyzes science data after the completion of the observations.
2. The Support Astronomer prepares the long-term and short-term scheduling.
3. Astronomer on-duty (AoD) supports and supervises the observations from a scientific point of view.
4. Operator: responsible for supervising and carrying out scheduled observations and calibrations during the night.
5. Configuration Manager: keeps track of the configuration of all instruments, part replacements, etc.
6. Maintenance Engineer: manages and executes maintenance activities and conducts on-site preventive and corrective maintenance tasks.

The Top Level Data Model document provides a conceptual view of the ASTRI Mini-Array data model, describing data products, data models and their relationship, to define interfaces, refer to data streams in architectural diagrams without ambiguity, define a short identifier for the data product. The concepts and the definitions described in this documents, in addition to the Glossary, have been used in all software documents developed by the ASTRI team.

The Top Level Architecture document provides a comprehensive architectural overview of MASS. This document, using a number of different views, depicts different aspects of the software and describes the significant architectural decisions. This document covers the Logical View and partially the *Process View* and the *Deployment View*.

In the ASTRI software context use cases not only cover a behavioural aspect of the system, but they are used to specify functional aspects. These use cases, coupled with the *Logical View*, provide a full view of the functional requirements of the software.

These top level documents has been used to develop detailed use case documents, software requirement and detailed design documents of each software subsystem, providing the traceability between the subsystem and the top level use cases and architectural elements.

4.2 ASTRI Mini-Array Software Main Systems

The general architecture of MASS is derived from the use cases, data models and data flow definitions and consists of the top-level systems described in this section. Fig. 3 shows the context view of MASS with the main software subsystems. In the following sections is provided an overview of these subsystems, with a short description of the main functionalities and a link with the observing cycle phases.

Assembly, Integration, Verification and Test (**AIT/AIV**) **Software** is also part of the software system and is connected with the LCS via OPC-UA interface. A local engineering GUI could be part of the AIV/AIT Software.

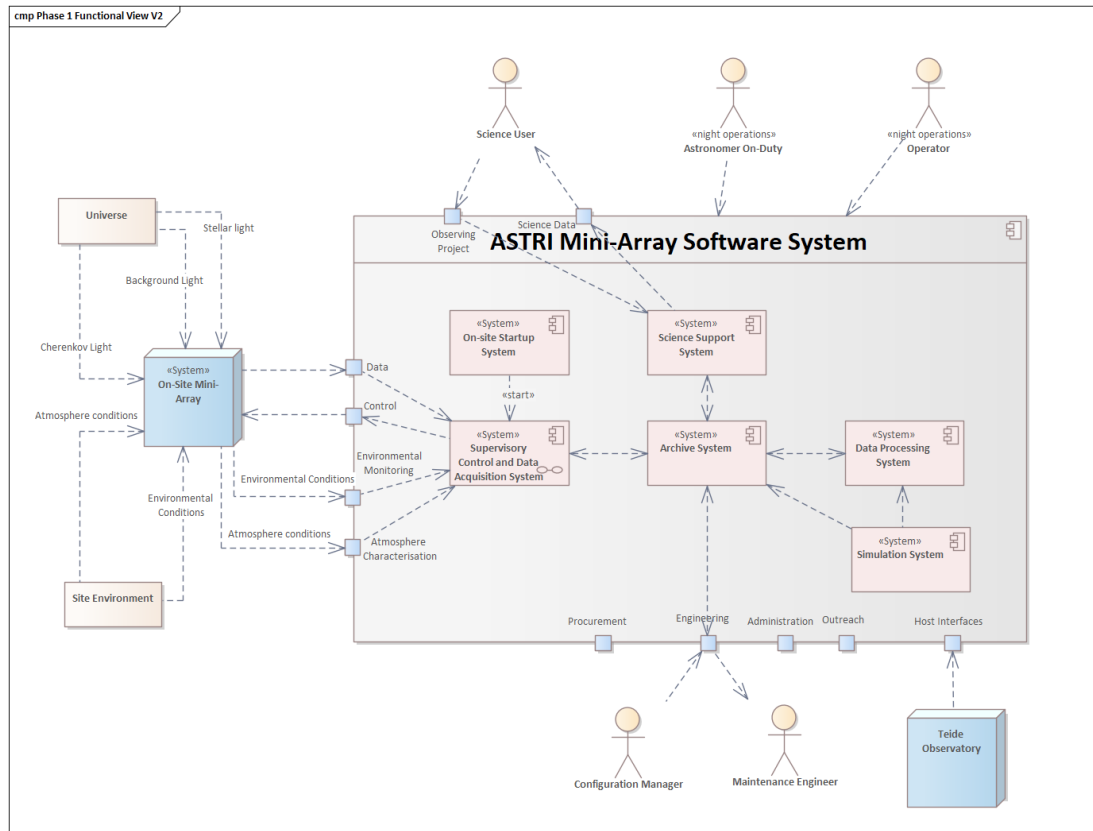

Figure 3. Context view of the ASTRI Mini-Array Software System. Its software systems are shown.

4.2.1 Archive System

The Archive System (see Fig. 4 with the connected data models) provides a central repository for all persistent information of the ASTRI Mini-Array such as Observing Projects, observation plans, raw and reduced scientific data, monitoring data, system configuration data, logs of all operations and schedules. The main archives are:

1. **Bulk Archive:** to store data and calibration from scientific instruments;
2. **Science Archive:** to manage observing project, observation plans and the science data model (see Sect. 4.4);
3. **System Configuration Database:** to store the configuration of the ASTRI Mini-Array System.
4. **Monitoring Archive, Log Archive, Alarm Archive:** stores logs, monitoring points and alarms produced by hardware and software on-site subsystems. Monitoring Archive stores also the products of the Environmental Monitoring System and Atmosphere Characterisation System.
5. **Quality Archive:** stores the Cherenkov and intensity interferometry observation quality checks during the observation.
6. **CALDB:** it is the calibration data base and stores instrument response functions and other instrumental and pre-computed quantities.
7. **Simulation Archive:** it contains all the Monte Carlo simulated events.

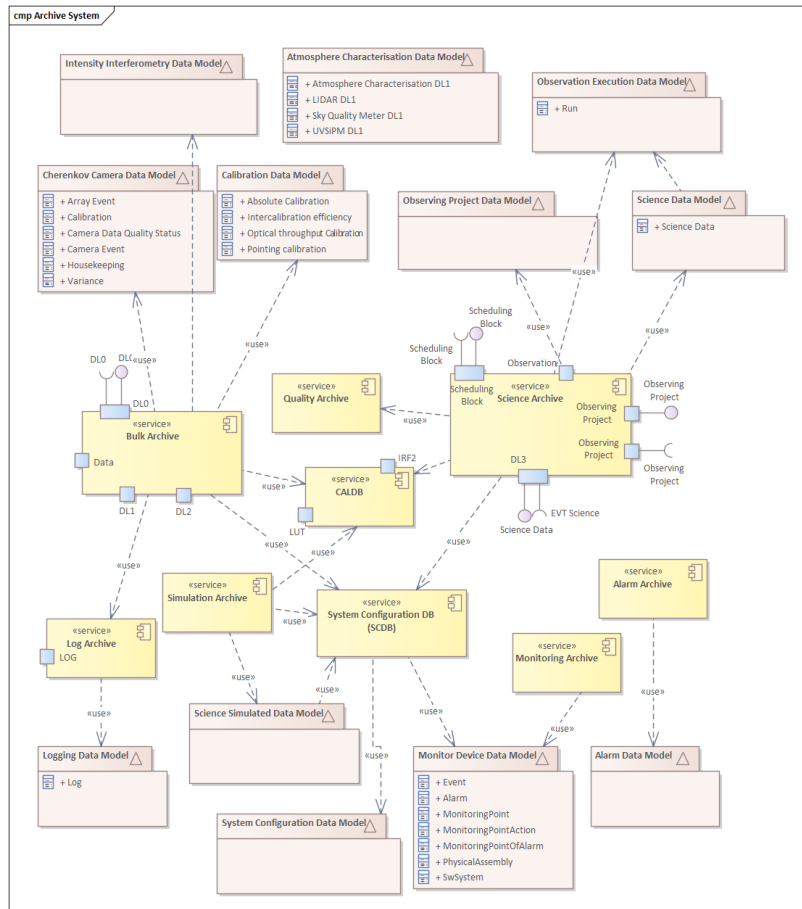

Figure 4. Archive System and the relationship of each archive with the data models

4.2.2 Science Support System

The **Science Support System** manages the Observing Projects, the observation plans preparation, the dissemination of scientific data and the science tools for their analysis. It is the main interface for Science User to the ASTRI Mini-Array system and provides them with an easy-to-use Science Support System Human Machine Interface for the detailed specification of observations. The main products generated by this system are the Scheduling Blocks and observation plan. The Science Support System also contains the Science Gateway, a web interface that shall be used to access high-level science-ready data and data products delivered by the Data Processing System. This system supports the *Observation Preparation* and the *Dissemination phase* of the observing cycle. The main functions are (see Fig. 5):

1. Observing Project Handler: to submit Observing Projects, to store the long-term observation plans and to select the short-term observation plans for the next night;
2. Observation Scheduler: to support the preparation of long-term observation plans, short-term observation plans and Observing Project preparation;
3. Science Gateway: to retrieve science-ready data, science tools and tools to support the Observing Project preparation.

4.2.3 Supervisory Control and Data Acquisition System

The Supervisory Control and Data Acquisition (SCADA) system controls all the operations carried out at AOS. SCADA has a Central Control System which interfaces and communicates with all assemblies and dedicated

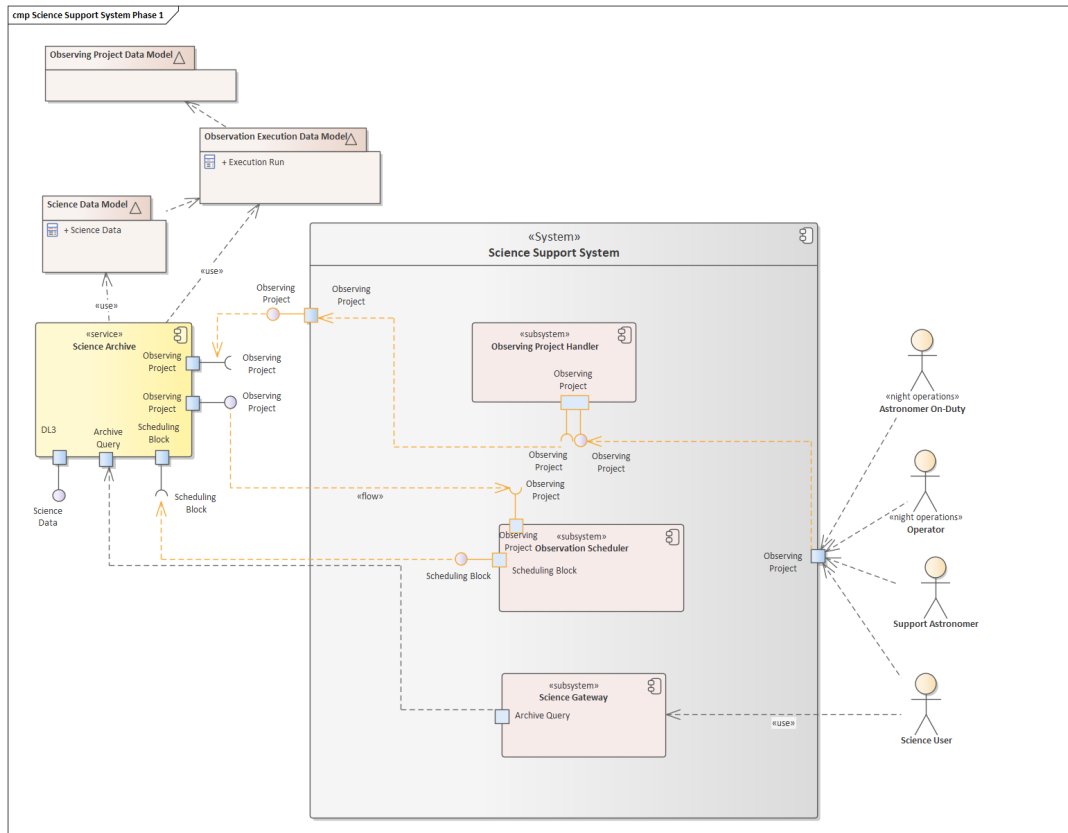

Figure 5. Science Support System component diagram with the Science Archive and related data models.

software installed at the site. It is responsible for the execution of the Scheduling Blocks to perform observations. SCADA shall normally be supervised by the Operator but performs the operations in an automated way. It shall provide scientific data, logging, monitoring, alarm, and online observation quality information to help assess the quality of data during the acquisition. This system supports the day and night *Observation Execution* and maintenance phases. The main functions are:

1. Control systems, to control, monitor, manage alarms and the status of the telescopes (Telescope Control System,^{11,12} developed by INAF based on the ASTRI-Horn experience), of the assemblies used to characterise the atmosphere (Atmosphere Characterisation Control System), and of the calibration system (Array Calibration Control System);
2. Collectors, to monitor, and determine alarms and the status of environmental devices (Environmental Monitoring System Collector), of the Information and Communication Technology (ICT) system¹³ (On-site ICT System Collector), of the power system (Power Management System Collector), of the Safe and Security System (Safety and Security System Collector);
3. Central Control System, coordinates the sequence of operations, coordinating the control systems and collectors, and the sequences of startup, shutdown, configure and checks the status of the on-site ASTRI Mini-Array Systems, get and verify Scheduling Blocks, execute the Observing Block interpreting the observing mode specified to command the telescopes and other subsystems. A Data Capture saves the information associated with the execution of an Observing Block (see Sect. 4.4);
4. Array Data Acquisition System,^{14,15} developed by INAF, acquires Cherenkov Cameras and Stellar Intensity Interferometry Instruments data, that are saved in the Bulk Archive;

5. Online Observation Quality System,⁹ developed by INAF, focuses on ongoing problems and status of the observations. Results are saved in the Quality Archive;
6. Logging System, Monitoring System and Alarm System,¹⁶ developed by INAF, monitor the overall performance of the systems through the acquisition of environmental, monitoring and logging points and alarms from instruments and generates status reports or notifications to the Operator. Data are saved in the Logging Archive, Monitoring Archive and Alarm Archive respectively;
7. Operator Human Machine Interface (HMI), developed by the University of Geneva, is the user interface for the Operator, including an Operator Logbook to save logs of the observations during the night.

The Central Control and some control systems and collector are be developed by a private company.

Each SCADA subsystem could provide an **Engineering GUI**, i.e. a dedicated GUI for development and test purposes.

SCADA is developed using the ALMA Common Software (ACS)[†]. ACS is a container component framework, designed for distributed systems, with standardized paradigms for logging, alarms, location transparency, and support for multiple programming languages: Java, C++ and Python. ACS has been used successfully for ALMA, which manages an array of 66 antennas on the Chajnantor plateau in Chile. ACS has also been used for ASTRI-Horn and the Sardinia Radio Telescope, and is used also for CTA. Most of the Mini-Array's software developers in INAF are therefore familiar with the use of ACS.

4.2.4 Data Processing System

The Data Processing System¹⁷ (DPS) (see Fig. 7) performs the calibration of scientific data, data reduction and analyses. It also checks the quality of the final data products. Its primary role is to process data, retrieved from the Archive System, as soon as enough data has been acquired to make such reduction meaningful. Typically, processing will be performed on data sets arising from a Scheduling Block. This system supports the observing cycle *Data Processing* phase.

The main functions are: (i) Stereo Event Builder:¹⁸ perform the off-line software stereo array trigger of Cherenkov data; (ii) Cherenkov Data Pipeline:¹⁷ data calibration, reconstruction, selection, and automated scientific analysis of Cherenkov data; (iii) Intensity Interferometry Data Reconstruction and Scientific Analysis:⁵ reconstruction and analysis of the Stellar Intensity Interferometry data; (iv) Calibration Software.¹⁷

4.2.5 Simulation System

The Simulation System provides Monte Carlo simulated scientific data for the development of reconstruction algorithms and for the characterisation of real observations. More details about this system are provided in.¹⁶

4.2.6 On-site Startup System

The On-site Startup System shall manage the sequence of the startup and shutdown of the on-site systems.

4.3 Operation of the MA software system

In this section is presented an analysis of the Top Level Use Cases to provide a skeleton of the architectural process view, summarised in Fig. 8 with an UML collaboration diagram which describes the workflow and the main operation of MASS.

The following numbering is reported in Fig. 8. The main software systems work together in the following way: the Science Support System is responsible for the management of Observing Projects submitted by Science User (1) and provide support to prepare observing plan and associated Scheduling Blocks stored in the Archive System (1.1).

At the beginning of the night the validated short-term observation plan with all the relevant information (e.g. target and pointing coordinates, observing mode, Observing Block duration) is uploaded from the Science

[†]<https://confluence.alma.cl/display/ICTACS/ACS+Documentation>

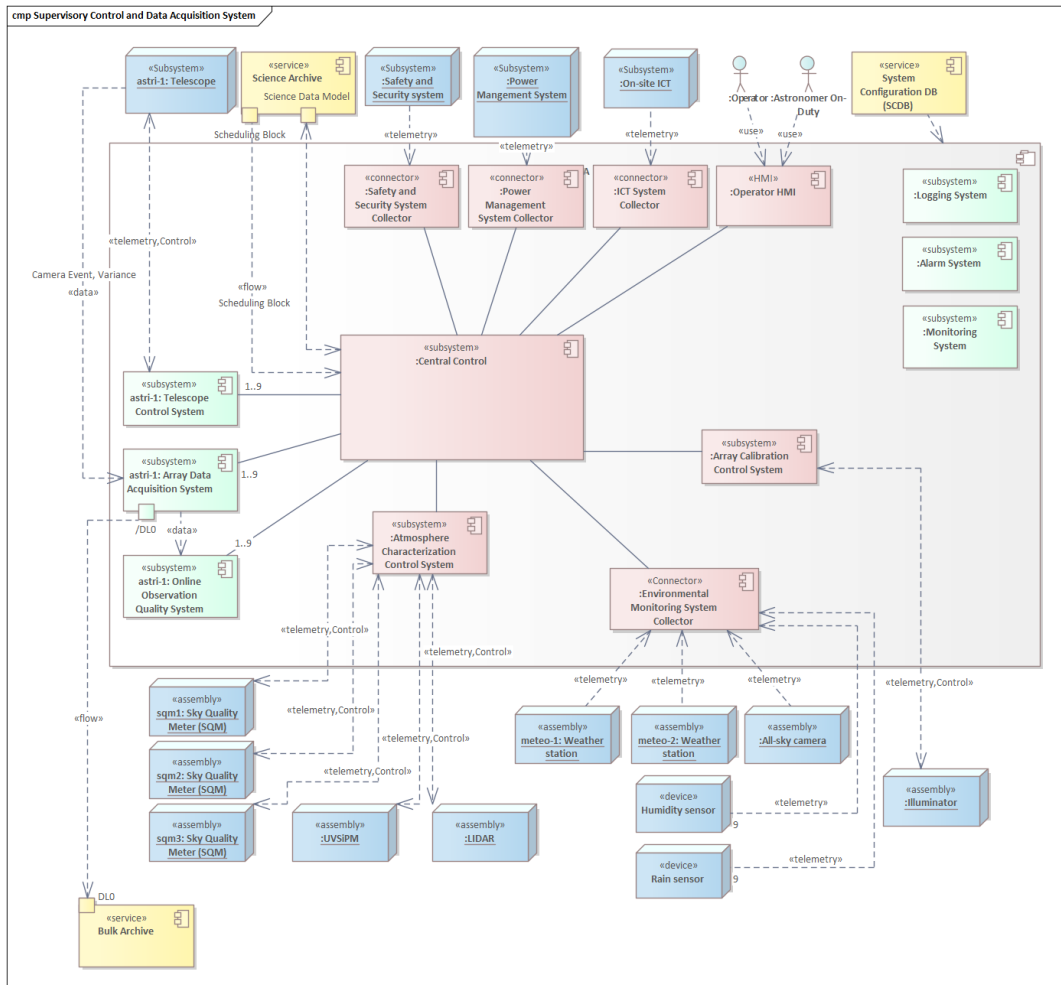

Figure 6. SCADA component diagram. Logging system acquires logs from all systems. Monitoring system acquires monitoring points from all assemblies and software systems. Alarm system receives alarms from assemblies. Only one telescope (and related subsystems) is shown, but there are nine independent chain of control, data acquisition and quality checks. Not all connections are shown, in particular the interconnections between Control Software/Collectors and Central Control are not shown and all connection between Alarm System, Monitoring System and Logging System are not shown. Red and green boxes are the SCADA system, where green boxes are under development by INAF team; blue boxes are the ASTRI Mini-Array assemblies; yellow boxes part of the Archive System. The *<< telemetry >>* stereotype represents monitoring points, alarms, errors, logs, and status information, *<< data >>* stereotype represents the data flow. The *<< control >>* stereotype represents the control flow. DL0 is the raw data generated by scientific instruments.

Archive. The selection of an observation is performed automatically by the Central Control System or manually by the Operator (2), that makes a quick cross-check of the status of the array and the environmental conditions through the Operator HMI. The validated short-term observation plan for the night is retrieved to be executed in manual mode or setting the Central Control System in automated mode (2.1). The observation is managed by the Central Control System that fetches the Scheduling Block from the Archive (2.2). The Central Control System configures the array assemblies, starts the Data Acquisition (2.3), and the Online Observation Quality System (2.4). The Alarm System and the Monitoring System have already been started before the observing night.

When the systems are ready the Operator starts the observation (3), and the Central Control System manages the list of Observing Blocks in an automated way. A Run is the execution of an Observing Block with an associated identifier. During the observation, the Data Acquisition acquires and saves raw data in the Local Bulk

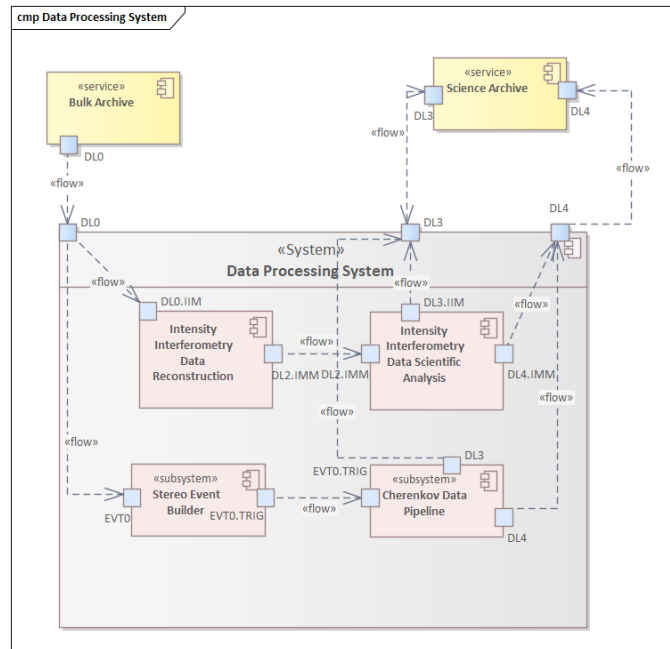

Figure 7. Data Processing System component diagram. DL0 is the raw data generated by scientific instruments, where IMM is the Intensity Interferometry data and EVT is the Cherenkov data. EVT0.TRIG is the Cherenkov data after the stereo array trigger. DL3 and DL4 are the scientific products. Components are described in the text.

Repository (3.1), while the Online Observation Quality system focuses on ongoing problems on data quality (3.2) and sends a report to the Operator HMI. The Data Capture of the Central Control System prepares the Science Data Model (see Sect. 4.4) during the observation, i.e. collects all the engineering and auxiliary information needed by the Data Processing System to reduce and analyze the scientific raw data.

During the observation, the Operator checks the status of the observation through the Operator HMI. The Central Control System sends the information about the status of the observation (3.3), providing feedback to the Operator. Logging System (3.4) and Monitoring System (3.5) send information to the Operator HMI. Alarm System sends alarms to the Operator HMI (3.6). Science Data Model are stored in the Science Archive (3.7) and the raw data is stored in the Bulk Archive (3.8).

When a Run is finished the raw data (4.1) and the Science Data Model (4.2) are transferred to the Bulk Archive. A short-term analysis is performed at the end of the data transfer of a Run (4.3), with the aim to produce preliminary science products, which will be stored in the Archive System (4.4).

When data is ready in the off-site Archive, the long-term data analysis is started by the Data Processing Manager. The Data Processing System pipeline retrieves raw data and metadata (the Science Data Model), as well as calibration coefficients (CAL1), look-up-tables (LUTs) and instrument response functions (IRFs) needed for Cherenkov data characterization and scientific analysis, from the Archive System and performs the full data reduction. The Data Processing System pipeline generates the final science-ready data and automatic science products and stores them in the Archive System. Ahead of the Cherenkov data analysis, a stereo event building procedure is executed by means of an offline software array trigger. This step is essential to fully exploit the stereoscopic capability of the array.

When science-ready data and science products are computed, they are made available from the Archive System by the Science Support System to the Science User (1.2).

4.4 Telescope domain, science domain and data models

The software that makes up the ASTRI Mini-Array System can be divided into *telescope domain* and the *science domain*. The classification is based on data models connected with each software system.

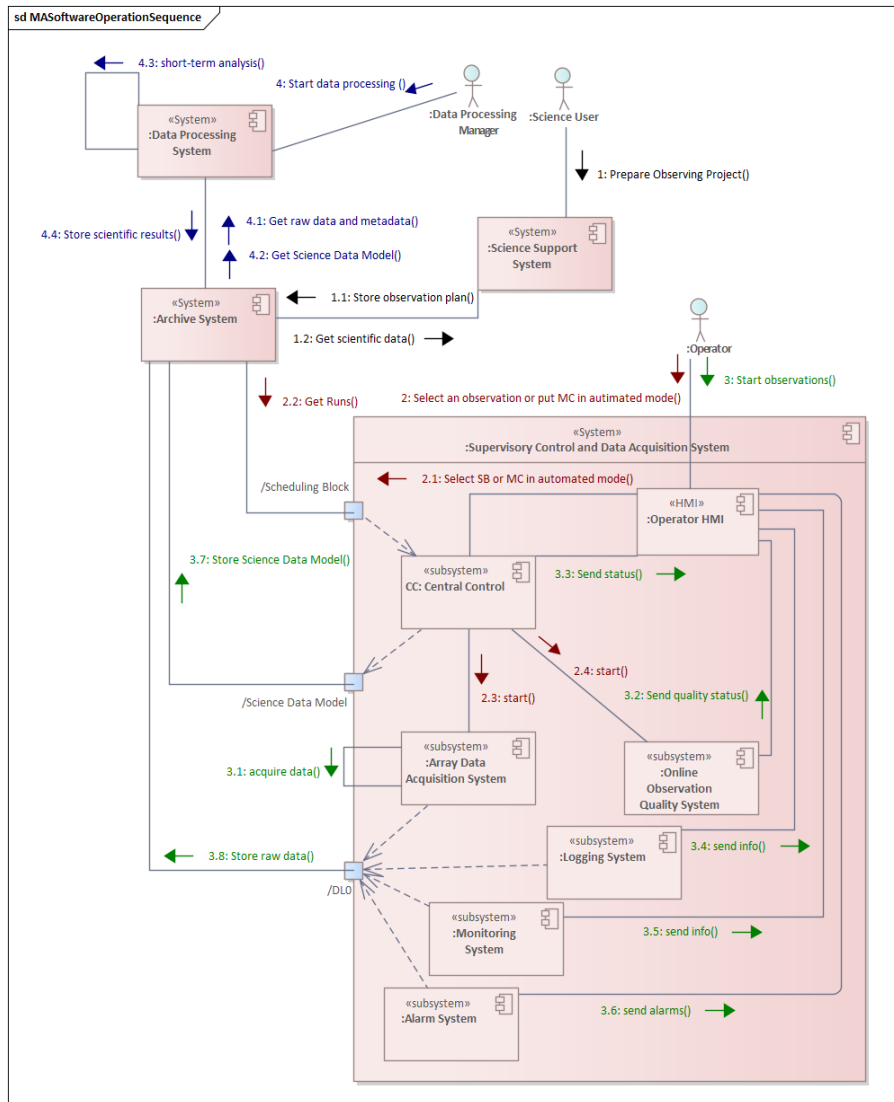

Figure 8. Operations of the ASTRI Mini-Array Software System. The numbered arrows indicate steps in the creation and processing of an Observing Project through to data reduction and storage in the Archive. See text for more details. Path (5) is not shown.

The Science Support system is in the science domain.

For SCADA, the Central Control System, the Array Data Acquisition System, the Alarm System, the Logging System and the Monitoring System, the Telescope Control Systems, on the other hand, are clearly in the telescope domain. The actual execution of a Scheduling Block by the Central Control consists of the execution of a sequential series of Observing Blocks. The Online Observation Quality System results are connected with an Observing Block but show the status of the current observation, and for this reason, this system has aspects of both domains.

The Data Capture, part of the Central Control System, provides the bridge between these two domains. The Data capture takes the instrument-centric, time-ordered stream of data, collects and extracts those items needed in the science domain, and re-organizes them to be useful in the data processing. Practically, it is responsible for collecting the auxiliary data associated with the Observing Block execution (a.k.a. the Run). These links to the acquired data, the observation and the auxiliary data are called Science Data Model. They are necessary for

the downstream subsystems to interpret the scientific data as they arrive. For these reasons, the Science Data Model is the link between the two domains. **Science Data Model** (SDM) defines the collection of information recorded during an observation that is needed for scientific analysis. It establishes a relationship between the Observing Project and the observation. Figure 9 provides the links between Data Capture and the data models in the telescope and science domains.

Data Processing, whose purpose is to produce calibrated data products, is in the science domain. The acquired data may be accumulated over many Runs, and the Data Processing pipeline manages and merges the results requiring data from different Runs. One of the inputs of the Data Processing system is the Science Data Model.

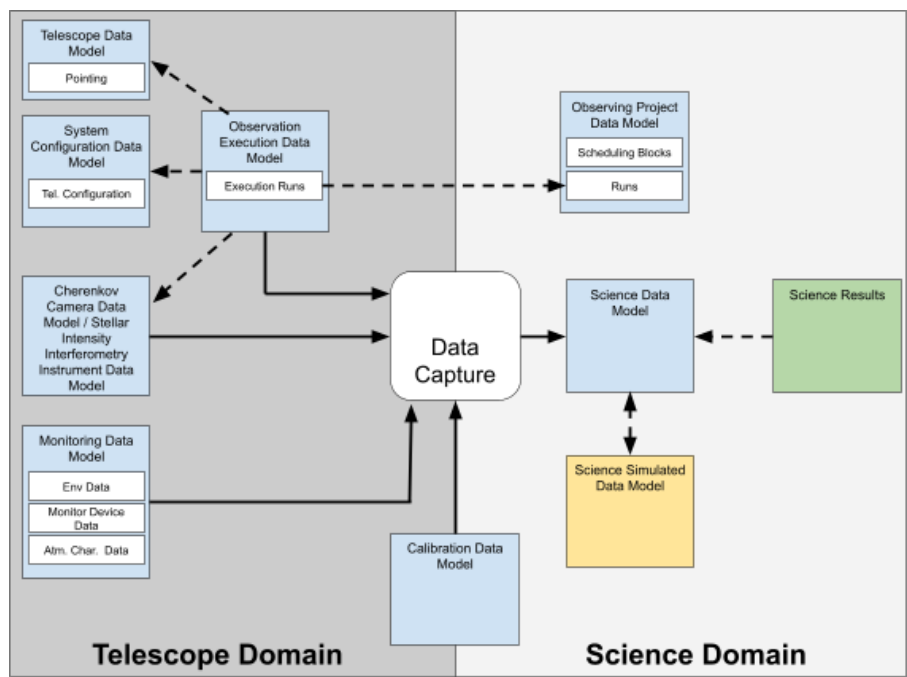

Figure 9. The Data Capture and the data models in the telescope and science domains. A solid line indicates data flow, dashed lines indicate referencing. Data flow streams from left (“upstream”) to right (“downstream”), although there could be some flow upstream to the Data Capture. The double referencing between the Science Data Model and the Science Simulated Data Model means that simulations are linked with the corresponding Science Data Model and vice versa. The information collected by the Data Capture are: (i) observing data (Cherenkov Camera data model, Stellar Intensity Interferometry Instrument data model), (ii) observing process description (Observing Project data model, Observation Execution data model, Telescope data model), (iii) configuration, (iv) monitoring data (Environmental data model, Atmosphere Characterisation data model), some data products of the Monitoring data model), (iv) some logging data.

5. SOFTWARE ENGINEERING APPROACH

The ASTRI software system engineering office is part of the ASTRI System Engineering activities of the ASTRI Project Office. It interacts with all ASTRI work packages because it delivers coordination and integration services for the development of ASTRI software. The ASTRI **software system engineer team** defines guidelines and planning for the ASTRI software development and installation for the ASTRI Mini-Array project with responsibility and accountability for all aspects of the project assigned by the ASTRI Project Office. The team is coordinated by a software system engineer. The software engineering team coordinates its activities with the ASTRI quality, safety and science teams.

5.1 Customer-supplier relationship

The production of MASS requires the cooperation of several INAF work groups and external organisations that share the common objective of providing a software system that satisfies the overall scientific and technical requirements of the ASTRI system. To organise the overall team, a **customer-supplier** relationship model has been adopted, where the customer procures the software, having one or more software suppliers that must develop software according to the customer requirements. This relationship is recursive, i.e. often, the customer is also a supplier to a higher-software level customer.

MASS suppliers are both INAF teams of different institutes, other public research institutions, such as the University of Perugia and INFN, other research institutes and industrial partners. An external company supplies part of the software of the SCADA system. INAF has in charge of software management and coordination, requirements specifications, top-level architecture definition, development, integration, and verification of all the sub-work-packages (sub-WPs).

This organisation defines a complex customer-supplier chain that requires overall project management following a structured approach throughout all stages of the software life cycle and at all levels of the customer-supplier chain that integrates all management, engineering and product assurance activities required for the execution of the project.

The **software system engineer** is the top-level customer of the customer-supplier chain for the software. The **software coordinator** and the deputy software coordinator are the suppliers that must provide the software systems identified in Sect. 4. Each software subsystem coordinator (SCADA, Archive, Simulation, Data Processing, Science User Support) is a supplier for the software coordinator. Each software subsystem coordinator has in charge of managing the effort provided by ASTRI developers, external contractors and research institutes.

5.2 The software development life cycle

A Software Development Plan has been defined and includes aspects of agile development methodologies, including (i) frequent iterations and releases; (ii) feature-driven development; (iii) unit and component tests created with the source code by the development teams during each iteration; (iv) automated testing and continuous integration; (v) distributed configuration management.

The software engineering team has developed verification and validation plans. The Quality Assurance team defined the Quality Assurance Plan. All suppliers of the ASTRI software follow these plans. The supplier performs the verification procedures to test the system as a white box; the customer performs validation with the system as a black box.

The following major reviews are foreseen in the ASTRI Mini-Array software life cycle:

1. Concept Design Review (CoDR): this review demonstrates that a full view of the software is compliant with science requirements, system requirements, observing cycle, and operation concepts.
2. Preliminary Design Review (PDR): this review demonstrates that the preliminary design of the subsystem meets all system requirements with acceptable risk and within the cost and schedule constraints and establishes the basis for proceeding with detailed design. Documentation describing the baseline design is the output of this review. The end of this review starts the iterative and incremental phase of the development.
3. Critical Design Review (CDR): the scope of this milestone is to demonstrate that the design reached an appropriate level of detail to support the production of the code, assembly, integration and test, meeting all performance, scheduling, and operational requirements. This review is part of an iteration, but not all iterations foresee a formal CDR. Based on the scope of the iteration, only an update of the documents should be required.

4. Acceptance Test Review (ATR): the scope of the review is to verify the completeness of the developed software, documentation, and test and analysis reports. Also, it ensures that the software reaches a level of maturity to be deployed. After this review, the software is delivered to the customer and deployed at the Array Observing Site or in the Data Center.
5. Operational Readiness Review (ORR): the scope is to establish that the software system is ready to be used for operations by examining test results, analyses, and operational demonstrations. It also shows that documentation is complete for each software configuration item. For SCADA, this review must be performed at the ASTRI Array Observing Site (the operational environment).

Based on these reviews, a V-model has been adopted for the entire software life-cycle, as shown in Fig. 10. The main phases can be summarised as follows:

1. System Definition phase: the entire software system has been defined. This phase was closed in June 2020 by a Concept Design Review (CoDR), conducted by a panel of external reviewers. After this review, the set of documents described in Sect. 4.1 was released. The Product Breakdown Structure, part of these deliverables, was used to define the Work Breakdown Structure of the software for the definition of the customer-supplier chain and assigning responsibility for each software subsystem.
2. Subsystem requirement and preliminary design phase. This phase is conducted at the subsystem level and is closed by a PDR. The main output is the detailed use cases and drafts of the software requirement document (SRS) and the detailed design document. A risk analysis is also performed at this level. The only mandatory documents of this phase are the detailed use case document and functional decomposition of the software. The set of documents and the level of details are agreed upon between the customer and the supplier. Usually, an agreement is reached that the details of the architecture will be defined during the next phase. SCADA team conducted the Preliminary Design Review for some SCADA subsystems (Telescope Control System, Monitoring System, Array Data Acquisition System, Online Observation Quality System) in Spring 2021, with a panel of reviewers of the software system engineering team.
3. Subsystem development iteration. After a subsystem PDR, the development of the subsystem starts in an iterative and incremental way. The number and size of each iteration depend on the subsystem. Iterations are agreed upon between customer and supplier based on the milestones foreseen by the ASTRI Mini-Array project connected with hardware procurement and related deployment. The starting point of each iteration is the selection of a detailed use case or only some steps of a detailed use case. Each iteration has the following phases:
 - (a) detailed design. The design or an update of the detailed design documents released in a previous iteration is foreseen. For each iteration the test procedures are defined in advance for verification purposes. The detailed design document is also updated at the end of the iteration before the release of the software.
 - (b) development of the software, including Continuous Integration (CI) at the subsystem level using the GitLab CI environment for automated subsystem verification. If all tests pass, the software is released with the updated documentation. In addition SonarQube has been installed and connected to the GitLab projects. The new commit of code triggers the Sonar scanner, which provides the quality report and a tag pass/fail according well defined quality metrics. These tests are performed in a testing environment. For SCADA subsystems (e.g. Telescope Control System, Monitoring System), the use of hardware simulator of assemblies that must be controlled or monitored is foreseen.
4. Software integration, delivery and deployment iteration:
 - (a) Software integration, verification and validation to integrate all delivered subsystems of a software system (e.g. Data Processing System) in the representative testing environment. At the end of this phase, the entire software system is delivered. An Acceptance Test Review is foreseen. The software system is ready to be deployed at the Array Observing Site (for SCADA) or in the Data Center. A subsystem test case can be executed manually for acceptance purposes.

- (b) Software system deployment and system integration. SCADA is deployed at the Array Observing Site, or off-site software systems (e.g. Data Processing System, Science User Support) are deployed in the Data Center. The Archive system is distributed between off-site and on-site, but the final version of the Archive system is off-site. At the Array Observing Site, the integration with the hardware assemblies and related validation procedures is foreseen. Integration of different software systems (e.g. SCADA with the Data Processing System) is performed at this level. This phase is closed by an ORR.

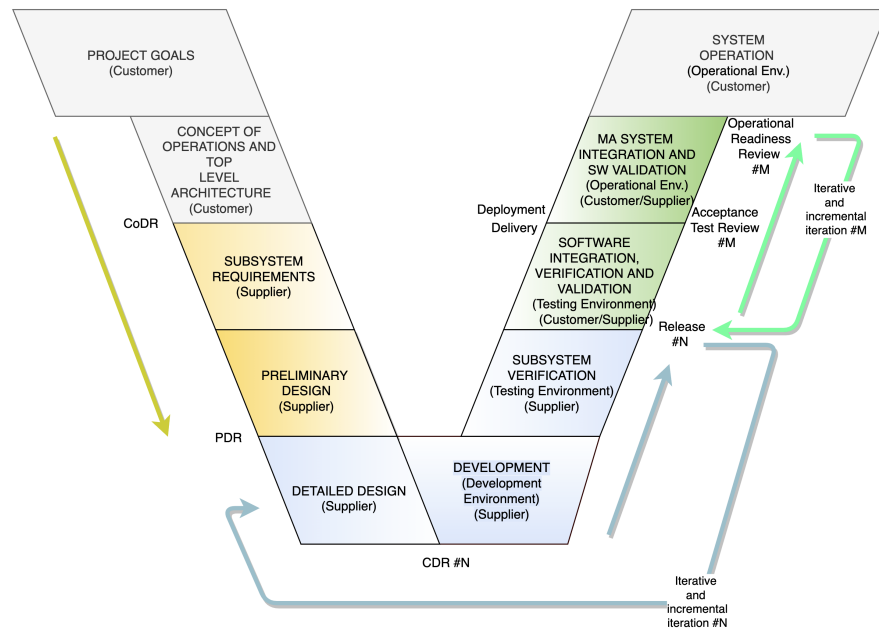

Figure 10. ASTRI Mini-Array Software software life-cycle and reviews.

This process is not linear and sometimes requires some synchronisation points between subsystems of a system. After some iterations, we discovered that a general internal Critical Design Review for the SCADA subsystems developed by INAF was necessary. The primary purpose was to align the internal SCADA interfaces, verify the consistency of documentation and the compliance with the top-level documents, and align documents, including lessons learned during the iterations from other subsystems, and update the risk analysis after one year of development. This review was conducted in Spring 2022 with a review panel of the software system engineering team.

5.3 Tools and standards

The Unified Modelling Language (UML) is used to design the software. Requirements and design are managed and documented using the Enterprise Architect tool[‡].

Released documents are managed following the ASTRI guidelines. The selected tool for the version control of the documents is the DMS plugin of Redmine[§].

The code is fully managed using the INAF GitLab repository[¶], including the continuous integration provided by the GitLab framework. Also, a SonarQube^{||} installation is integrated with Gitlab to perform the static code

[‡]<https://sparxsystems.com/>

[§]<https://www.redmine.org/>

[¶]<https://www.ict.inaf.it/gitlab/>

^{||}<https://www.sonarqube.org/>

analysis.

Dockers** and an official ASTRI virtual machine are used for development, continuous integration and deployment. In addition, a test bed, which reproduces a configuration very similar to the production environment, has been prepared to support the integration tests.

5.4 Release management

The release management concerns the whole software development life cycle. As presented in the previous sections, we plan to provide many releases according to the project schedule. Any release, in addition to the implemented software, shall also include the specific document version of the requirement specification, detailed design, test plan, test report and the user manuals related to the latest developed features. Eventually, the release document, which collects all the deliverables for a release, shall be published and shall be used for the personnel training.

5.5 The Software Quality Assurance approach

According to the ASTRI Mini-Array Product Assurance Plan,¹⁹ we also released a Software Quality Product Assurance Plan (SPAP) to establish the goals, the processes and the responsibilities to implement the effective quality assurance functions for the ASTRI Mini-Array software. The SPAP provides the framework necessary to ensure a consistent approach to software quality assurance throughout the project life cycle. It defines the approach that will be used by the Product Assurance Manager (PAM), the PA responsible for the software and all the actors involved to monitor and assess software development processes and products.

6. CONCLUSIONS

This paper provides the software engineering approach and a comprehensive architectural overview of the ASTRI Mini-Array Software system. This system manages observing projects, observation handling, array control and monitoring, data acquisition, archiving, data processing and simulations, and user support of the Cherenkov and intensity interferometry observations, including science tools for the scientific exploitation of the ASTRI data. This work described the main requirements and constraints that drive the definition of the architecture, using a number of different views, depicts different aspects of the ASTRI Mini-Array software and describes the significant architectural decisions.

ACKNOWLEDGMENTS

This work was conducted in the context of the ASTRI Project. This work is supported by the Italian Ministry of University and Research (MUR) with funds specifically assigned to the Italian National Institute of Astrophysics (INAF). We acknowledge support from the Brazilian Funding Agency FAPESP (Grant 2013/10559-5) and from the South African Department of Science and Technology through Funding Agreement 0227/2014 for the South African Gamma-Ray Astronomy Programme. IAC is supported by the Spanish Ministry of Science and Innovation (MICIU). This work has been supported by H2020-ASTERICS, a project funded by the European Commission Framework Programme Horizon 2020 Research and Innovation action under grant agreement n. 653477.

REFERENCES

- [1] Pareschi, G., “The implementation of the ASTRI Mini-Array gamma-ray experiment at the Observatorio del Teide, Tenerife,” in [*Ground-based and Airborne Telescopes IX*], Heather K. Marshall, Jason Spyromilio, T. U., ed., **Proc. of SPIE 12182** (2022).
- [2] Scuderi, S. and et al., “The astri mini-array of cherenkov telescopes at the observatorio del teide,” *Journal of High Energy Astrophysics* (2022).

**<https://www.docker.com/>

- [3] Sottile, G. and et al., “ASTRI-Horn Cherenkov camera: improvements on the hardware and software components,” in [*Advances in Optical and Mechanical Technologies for Telescopes and Instrumentation V*], Ramón Navarro, R. G., ed., **Proc. of SPIE 12188** (2022).
- [4] Pareschi, G. and et al., “The ASTRI SST-2M prototype and mini-array for the Cherenkov Telescope Array (CTA),” in [*Software and Cyberinfrastructure for Astronomy IV*], **Proc. of SPIE 9906** (2016).
- [5] Zampieri, L. and et al., “A Stellar Intensity Interferometry Instrument for the ASTRI Mini-Array telescopes,” in [*Optical and Infrared Interferometry and Imaging VIII*], Antoine Mérand, Stephanie Sallum, J. S.-B., ed., **Proc. of SPIE 12183** (2022).
- [6] Bonanno, G. and et al., “Focal plane detector and front-end electronics of the stellar intensity interferometry instrument for the ASTRI Mini-Array telescopes,” in [*Optical and Infrared Interferometry and Imaging VIII*], Antoine Mérand, Stephanie Sallum, J. S.-B., ed., **Proc. of SPIE 12183** (2022).
- [7] Germani, S. and et al., “The Pointing Monitoring Camera hardware and software systems for the ASTRI Mini-Array project,” in [*Advances in Optical and Mechanical Technologies for Telescopes and Instrumentation V*], Ramón Navarro, R. G., ed., **Proc. of SPIE 12188** (2022).
- [8] Impiombato, D. e. a., “UVSiPM: a light auxiliary detector to measure the night sky background seen by the ASTRI Mini-Array Cherenkov telescopes at the Observatorio del Teide,” in [*X-Ray, Optical, and Infrared Detectors for Astronomy X*], Andrew D. Holland, J. B., ed., **Proc. of SPIE 12191** (2022).
- [9] Parmiggiani, N. and et al., “The online observation quality system software architecture for the ASTRI Mini-Array project,” in [*Software and Cyberinfrastructure for Astronomy VII*], Jorge Ibsen, G. C., ed., **Proc. of SPIE 12189** (2022).
- [10] Kruchten, P., “The 4+1 view model of architecture,” *IEEE Software* **12**(6), 42–50 (1995).
- [11] Russo, F. and et al., “The Telescope Control System for the ASTRI Mini Array of Imaging Atmospheric Cherenkov Telescopes,” in [*Software and Cyberinfrastructure for Astronomy VII*], Jorge Ibsen, G. C., ed., **Proc. of SPIE 12189** (2022).
- [12] Corpora, M. and et al., “Design and development of the Supervisor Software Component for the ASTRI Mini-Array Cherenkov Camera,” in [*Software and Cyberinfrastructure for Astronomy VII*], Jorge Ibsen, G. C., ed., **Proc. of SPIE 12189** (2022).
- [13] Gianotti, F. and et al., “ASTRI Mini-Array On-Site Information and Communication Technology infrastructure,” in [*Software and Cyberinfrastructure for Astronomy VII*], Jorge Ibsen, G. C., ed., **Proc. of SPIE 12189** (2022).
- [14] Conforti, V. and et al., “The Array Data Acquisition System software architecture of the ASTRI Mini-Array Project,” in [*Software and Cyberinfrastructure for Astronomy VII*], Jorge Ibsen, G. C., ed., **Proc. of SPIE 12189** (2022).
- [15] Pastore, V. and et al., “Array Data Acquisition System interface for online distribution of acquired data in the ASTRI Mini-Array project,” in [*Software and Cyberinfrastructure for Astronomy VII*], Jorge Ibsen, G. C., ed., **Proc. of SPIE 12189** (2022).
- [16] Incardona, F., Costa, A., and et al., “The Monitoring Logging and Alarm System of the ASTRI Mini-Array gamma-ray air-Cherenkov experiment at the Observatorio del Teide,” in [*Software and Cyberinfrastructure for Astronomy VII*], Jorge Ibsen, G. C., ed., **Proc. of SPIE 12189** (2022).
- [17] Lombardi, S. Lucarelli, F. B. C. and et al., “The Data Processing, Simulation, and Archive Systems of the ASTRI Mini-Array Project,” in [*Software and Cyberinfrastructure for Astronomy VII*], Jorge Ibsen, G. C., ed., **Proc. of SPIE 12189** (2022).
- [18] Germani, S. and et al., “The Stereo Event Builder software system of the ASTRI Mini-Array project,” in [*Software and Cyberinfrastructure for Astronomy VII*], Jorge Ibsen, G. C., ed., **Proc. of SPIE 12189** (2022).
- [19] La Palombara, N., Conforti, V., and et al., “The Product Assurance programme of the ASTRI Mini-Array project,” in [*Modeling, Systems Engineering, and Project Management for Astronomy X*], George Z. Angeli, P. D., ed., **Proc. of SPIE 12187** (2022).