



Publication Year	2018
Acceptance in OA @INAF	2023-02-09T14:58:47Z
Title	X-RAY RASTER SCAN FACILITY FOR THE ATHENA MIRROR ASSEMBLY
Authors	MORETTI, Alberto; PARESCHI, Giovanni; USLENGHI, MICHELA; SIRONI, GIORGIA; Tordi, Massimiliano; et al.
Handle	http://hdl.handle.net/20.500.12386/33356

VERTICAL X-ray Facility (VERT-X)

Technical proposal in response to invitation to tender for X-
RAY RASTERSCAN FACILITY FOR THE ATHENA
MIRROR ASSEMBLY

REF: ESA AO/1-9549/18/NL/AR- Activity No. 1000023850 in the "esa-star" system



PREPARED BY : A. Moretti, G. Pareschi, M. Usigli, G. Sironi, M. Tordi,
G. Parissenti, G. Valsecchi

CODE: VERT-INAF/OAB-001

APPROVED BY : G. Tagliatori - Director INAF-OAB

VERT-X
ESA AO/1-9549/18/NL/AR
VERT-INAFOAB-004
Page 1-1

Table of Contents

1 TECHNICAL PART	1-7
1.1 TECHNICAL REQUIREMENTS AND SCOPE OF THE WORK	1-7
1.1.1 UNDERSTANDING OF THE MAIN TECHNICAL OBJECTIVES OF THE ITT	1-7
1.1.2 PROPOSED APPROACH TO REACH THE MAIN TECHNICAL OBJECTIVES OF THE ITT	1-9
1.2 FIRST ITERATION OF TASK 1	1-10
1.3 THE VACUUM TANK AND THE XRS HOUSING	1-11
1.3.1 VACUUM COMPONENTS	1-12
1.3.1.1 Vacuum Vessel	1-12
1.3.1.2 Thermal Components	1-15
1.3.1.3 Measuring and Monitoring System	1-15
1.3.1.4 Control System	1-15
1.3.1.5 Additional Features	1-16
1.3.1.6 Utilities	1-16
1.3.2 RASTER SCAN MECHANISM	1-16
1.3.2.1 General description	1-16
1.3.2.2 Base, bridge, and trolley	1-16
1.3.2.3 Gimbal mount and Serrurier truss	1-18
1.3.3 TIP/TILT METROLOGY	1-21
1.3.3.1 General Requirements	1-21
1.3.3.2 Tiltmeters	1-21
1.3.3.3 Optical metrology	1-23
1.3.4 CONTROL SYSTEM	1-25
1.3.4.1 Overview	1-25
1.3.4.2 Control HW	1-25
1.3.4.3 Interfaces	1-26
1.3.4.3.2 Interlocks	1-26
1.3.5 PRELIMINARY CALCULATIONS (FEM MODEL)	1-26
1.3.5.1 Vibrating modes	1-27
1.3.5.2 Deformations due to gravity	1-30
1.3.5.3 Deformations due to linear guides shape errors	1-31
1.3.5.4 Servo analysis	1-31
1.3.5.5 Error budget	1-35
1.4 THE QUESTION OF THE MA SUPPORT AND GRAVITY DISTORTIONS	1-36
1.5 THE X-RAY SYSTEM	1-37
1.5.1 THE X-RAY SOURCE	1-37
1.5.1.1 The X-ray Collimator	1-39

1.5.1.1.1	Design of the parabolic collimator	1-39
1.5.1.1.2	Intensity distribution of the collimated beam	1-41
1.5.1.1.3	Manufacturing and tolerance of the collimator	1-44
1.6	THE X-RAY SERVICE CAMERA	1-46
1.7	X-RAY SCANNING STRATEGY AND PERFORMANCE	1-47
1.8	THE BUILDING HOSTING THE X-RAY SCANNING FACILITY	1-49
1.9	OVERVIEW OF THE METROLOGY FOR THE X-RAY SCANNER	1-52
1.9.1.1	Mechanical Ground Support Equipment	1-53
1.10	POTENTIAL PROBLEM AREAS AND TRADE-OFF	1-55
1.11	TECHNICAL COMPLIANCE	1-63
1.11.1	TECHNICAL COMPLIANCE MATRIX (STATEMENT OF WORK/TECHNICAL REQUIREMENTS)	1-63
2	IMPLEMENTATION STRATEGY AND PROGRAMME OF WORK	2-68
2.1.1	PROPOSED WORK LOGIC	2-68
2.2	PROJECT ORGANIZATION	2-69
2.3	PROJECT ORGANIZATION	2-69
2.3.1	PROJECT TEAM	2-69
2.3.1.1	Background of the companies	2-70
2.4	ORGANISATION, RESPONSIBILITY AND KEY PERSONS	2-72
2.5	TEAM ORGANISATION AND PERSONNEL	2-73
2.6	OVERALL TEAM COMPOSITION, KEY PERSONNEL	2-73
2.6.1.1	Time dedication of key personnel	2-75
2.7	PROPOSED ACTIVITIES	2-76
2.7.1.1	Work Breakdown Structure (WBS)	2-76
2.7.1.2	Work Package Description (WPD)	2-77
2.7.2	PROPOSED SCHEDULE AND MILESTONES	2-91
2.7.3	BAR CHART	2-92
2.7.4	DELIVERABLE ITEMS	2-92
2.7.5	NON-CONFORMANCES/LIMITATIONS/ADDITIONS REGARDING DELIVERABLE ITEMS	2-93
3	FINANCIAL PART	3-94
3.1	PRICE QUOTATION FOR THE CONTEMPLATED CONTRACT	3-94
3.2	SUBCONTRACTING PLAN	3-94
3.2.1	PSS COSTING FORMS	3-94
3.2.2	MILESTONE PAYMENT PLAN	3-94
3.2.3	TRAVEL AND SUBSISTENCE PLAN	96
4	CONTRACT CONDITIONS PART	97

4.1	BACKGROUND INTELLECTUAL PROPERTY RIGHTS	97
4.2	SPECIFICATION OF ALL INPUTS TO ENTER INTO THE BLANKS EXISTING IN THE DRAFT CONTRACT	97
4.3	OTHER REMARKS ON THE DRAFT CONTRACT	97
4.4	MANAGEMENT AND ADMINISTRATIVE COMPLIANCE MATRIX	97
5	ANNEX 1: SIGNED PSS	99
6	ANNEX 2	132
6.1	CURRICULA OF KEY PERSONS	132
6.2	BACKGROUND OF INSTITUTES AND COMPANIES	147
6.2.1.1	EIE Group	147
6.2.1.2	Presentation of the EIE group	147
6.2.1.2.1	Previous projects in ground based astronomy	148
6.2.1.2.2	Previous projects in space astronomy	152
6.2.1.3	INAF (Brera and IASF-Mi)	157
6.2.1.4	Media Lario S.r.l.	161
6.2.1.4.1	Optics manufacturing technologies	161
6.2.1.4.2	Previous experience in space projects	162
6.2.1.4.3	Facilities	162
6.2.1.4.4	Media Lario heritage in X-Ray optics	164
6.2.1.5	GP Advanced Projects Organization	165
6.2.1	BCV PROGETTI	165

APPLICABLE DOCUMENTS (AD)

- [AD1] Invitation to Tender for X-RAY RASTER SCAN FACILITY FOR THE ATHENA MIRROR ASSEMBLY ESA AO/1-9549/18/NL/AR
- [AD2] ATHENA – Mirror Calibration Facility URD (and LBF<=>MA IRD/ICD), ESA- ATHENA- ESTEC-SYS-RS-0003, Issue 1.3, 23/08/2018.
- [AD3] System Engineering General Requirements, ECSS-E-ST-10C rev. 1, 15 Feb. 2017.

REFERENCE DOCUMENTS (RD)

- [RD1] ATHENA - Reference Telescope Design and Effective Area Estimates, ESA- ATHENA- ESTEC-PL-DD-0001, Issue 2.4, 16/02/2018.
- [RD2] ATHENA - Calibration Requirements Document, ESA-ATH-SP-2016-001, Issue 0.5.1, 24/04/2018.
- [RD3] ATHENA - Optics Calibration Plan, ESA-ATHENA-ESTEC-SCI-PL-0001 , Issue 1.1, 24/04/2018.
- [RD4] ATHENA- Science Requirements Documents SRE-S-ATH-2015-01, Issue 2.2

- [RD5] Summary of the 12th IACHEC Meeting, astro-ph 1708.01446
- [RD6] Nandra, K., Barret, D., Barcons, X., et al., "The Hot and Energetic Universe: A White Paper presenting the science theme motivating the Athena mission", <https://arxiv.org/abs/1306.2307> (2013)
- [RD7] Willingale, R., Pareschi, G., Christensen, et al., "Science requirements and optimization of the silicon pore optics design for the Athena mirror," Proc. SPIE 9144, 91442E (2014)
- [RD8] Bavdaz, M., Wille, E., Ayre, M., Ferreira, I., Shortt, B., et al., "Development of the ATHENA mirror", Proc. SPIE 10699, 106990X (2018)
- [RD9] Ayre, M.; Bavdaz, M.; Ferreira, I.; Wille, E.; Fransen, S.; Stefanescu, A.; Linder, M., ATHENA: system studies and optics accommodation, Proceedings of the SPIE, Volume 10699, id. 106991E 16 pp. (2018).
- [RD10] Barret, D., et al., The ATHENA X-ray Integral Field Unit (X-IFU), Proceedings of the SPIE, Volume 10699, id. 106991G 15 pp. (2018).
- [RD11] Meidinger, N., et al., The Wide Field Imager instrument for Athena, Proceedings of the SPIE, Volume 10397, id. 103970V 12 pp. (2017).
- [RD12] ATHENA - SIM-System Concept Report, ESA-ATHENA-ESTEC-SYS-DD-0001 (2018)
- [RD13] Krumrey, M., Muller, P., et al., "New X-ray parallel beam facility XPBF 2.0 for the characterization of the silicon pore optics," Proc. SPIE 9905, 99055N (2016)
- [RD14] Salmaso, B., Spiga, D., Basso, S., Ghigo, M., Giro, E., Pareschi, G., Tagliaferri, G., Vecchi, G., Pelliciani, C., Burwitz, V., Sanchez del Rio, M., Ferrari, C., Zappettini, A., Usigli, M., Fiorini, M., Parodi, G., Ferreira, I., Bavdaz, M., "Progress in the realization of the beam expander testing x-ray facility (BEaTrOX) for testing ATHENA's SPO modules", Proc. SPIE 10699, 1069931 (2018)
- [RD15] Valsecchi, G., Bianucci, G., et al., "Results of SPO mirror modules optical integration in the ATHENA telescope", Proc. SPIE 10699, 106990Z (2018)
- [RD16] Burwitz, V., Willingale, R., Pelliciani, C., et al., "Developing, testing, and calibrating the ATHENA optics at PANTER", Proc. SPIE 10399, 103990O (2017)
- [RD17] O'dell, S. L.; Weisskopf, M. C., "Calibration of the AXAF observatory: overview", Proc. SPIE Vol. 3113, p. 2-17 (1997)
- [RD18] Maeda, Y., et al, An X-ray calibration facility with a dynamical pencil beam for the post-Astro-E2 telescopes, Proceedings of the SPIE, Volume 4851, pp. 734-741 (2003)
- [RD19] Menz, B., Brauning, H., Burwitz, V., Hartner, G., Predehl, P., "Studying ATHENA optics with divergent and collimated x-ray beams," Proc. SPIE 9144, 91445J (2014)
- [RD20] Marchioni, G., and Rampini, F., "Final tests and performances verification of the European ALMA antennas", Proceedings of the SPIE, Volume 8444, article id. 84442J, 11 pp. (2012).
- [RD21] C. J. Bebek, et al. "CCD research and development at Lawrence Berkeley National Laboratory", Proc. SPIE 8453, High Energy, Optical, and Infrared Detectors for Astronomy V, 845305 (2012)
- [RD22] Pareschi, G., et al., "A vertical facility based on raster scan configuration for the X-ray scientific calibrations of the ATHENA optics", Proceedings of the ICSSO Conference, Crete 2018

ACRONYMS

AD	Applicable Document	MACS	Vacuum Vessel, pneumatic circuit
ALMA	Atacama Large Millimeter Array	Mirror	Assembly Cart
AKE	Required Absolute Knowledge Error	MAIT	Manufacturing Assembly Integrator and Test
ASI	Agenzia Spaziale Italiana	MGSE	Mechanical Ground Support Equipment
ATHENA	Advanced Telescope for High-Energy Astrophysics	MM	Mirror Module
BEATRIX	Beam Expander Testing X-ray facility	M2M	Machine to Machine
BMS	Building Management System	OAB	Osservatorio Astronomico di Brera (INAF, Milano)
CCD	Charge-Coupled Device	OGSE	Optical Ground Support Equipment
DMS	Detector Motion System	OPC-UA	OLE for Process Control - Uniflex Architecture
DOF	Depth of Focus	PA	Product Assurance
DPCS	Detector Positioner	PC	Personal Computer
EA	Effective Area	PID	Proportional-Integral-Derivative Control
EAP	EtherCAT Automation Protocol	PM	Project Manager
ECSS	European Cooperation for Space Standardization	PSF	Point Spread Function
E-ELT	European Extremely-Large Telescope e.g. exempli gratia (for example)	QA	Quality Assurance
EGSE	Electrical Ground Support Equipment	QM	Qualification Model
ESA	European Space Agency	RD	Reference Document
E2E	End-to-End	RMS	Root Mean Square
FEA	Finite Element Analysis	ROM	Rough Order of Magnitude
FEM	Finite Element Method	RS	Raster Scan
FM	Flight Model	SC	Spacecraft
FOV	field of view	SIM	Science Instrument Module
FWHM	Full Width at Half Maximum	SIMC	SIM cart
GS	Ground Segment	SIMCS	Science Instrument Module Cart
GSE	Ground Support Equipment	SNR	Signal-to-Noise Ratio
HEW	Half Energy Width	SoW	Statement of Work SW Software
HW	Hardware	SPO	Silicon Pore Optics
ICD	Interface Control Document	ThCS	Vacuum Vessel, thermal control
IASF	Istituto di AstroFisica Spaziale (INAF, Milano)	TTL	Transistor Transistor Logic
i.e.	id est (that means)	TCWG	Telescope and Calibrations Working Group
INAF	Istituto Nazionale di AstroFisica	URD	User Requirement Document
IRD	Interface Requirement Document	VERT-X	Vertical X-ray raster-scan facility
ISO	International Standards Organization	w.r.t.	with respect to
ITT	Intention to Tender	XRCS	XRS Control System
LAN	Local Access Network	XRMACS	XRS Monitoring and Auxiliary Control System
LBF	Long Bean Facility	XRS	X-ray Raster Scanner
MA	Mirror Assembly		
MA	Mirror Assembly Cart		

1 TECHNICAL PART

1.1 TECHNICAL REQUIREMENTS AND SCOPE OF THE WORK

1.1.1 Understanding of the main technical objectives of the ITT

The Advanced Telescope for High-Energy Astrophysics (ATHENA) is an X-ray telescope designed to address the Cosmic Vision science theme 'The Hot and Energetic Universe'. The primary goals of the mission are the mapping of the hot-gas structures of our Universe and determining their physical properties in view to understand how ordinary matter assemble into the large-scale structures we see today.

The technology of Silicon Pore Optics (SPO) was selected since 2004 as the baseline for making the X-ray Mirror Assembly, consisting of approximately 700 mirror modules to obtain a nested Wolter-like optics. The maximum diameter of the shells will be 2.5 m while the focal length is 12 m. The requirements for on-axis angular resolution and effective area at 1 keV are 5 arcsec HEW and 1.4 m², while the field of view will be 40 arcmin in diameter (50 % vignetting) [RD1].

While an effort to demonstrate the feasibility of a so large optics with so stringent scientific requirements is ongoing, an important aspect to be considered regards the scientific calibrations of the X-ray optics. The calibration requirements [RD2, RD3] essentially consist in the accuracy level to which the telescope response should be known to achieve the mission science goals and directly follow from the science requirements [RD4].

Table 1-1: The required absolute knowledge error (AKE) in the mirror calibration shall be smaller than the values here indicated [RD3].

Ref. number	Requirement	MA value
AST-R-02	Focal length (on ground)	1 mm
AST-R-05	Optical axis (w.r.t MA_PCS)	10"
AST-R-07	Position of the detector w.r.t. mirror	0.25 mm
PSF-R-01	PSF HEW	0.1°/0.1°/0.5° core/extended-core/wings
PSF-R-02	PSF 2D shape	0.1°
EEF-R-01	Absolute effective area on axis	6%
EEF-R-03	Relative effective area on-axis	2%
EEF-R-04	Relative effective area off-axis	4%
EEF-R-05	Relative effective area, fine structure	1%
BKG-R-03	Stray light	5%

The total error budget requirement is split among the different components of the telescope, which are detectors, MA, S/C and GS [RD3]. The required absolute knowledge error (AKE) in the mirror calibration in terms of PSF and effective area are listed in [RD3] and here reported in Table 1-1 for simplicity.

While the requirements for ground calibrations are not explicitly set (with respect to flight values), some of the parameters can be better measured on ground. Indeed, according to [RD3], most of the calibration specifically relevant for MA should be better performed on ground: these are the PSF wings and the off-axis performance (vignetting). In our view the absolute calibration of the effective area at the required level can also be performed only on ground, since, as shown in recent literature, on flight calibrations are affected by systematic uncertainties which are extremely difficult to be eliminated (see for example [RD5] and references therein).

The alignment, testing and scientific X-ray calibrations of the designed ATHENA X-ray Mirror, in its fully or partial assembly, will require a check of the overall mirror performance in X-rays. The tests in X-rays of the single SPO mirror modules will be done using monochromatic X-ray pencil-beams at the DESY synchrotron facility and using the BEATRIX testing facility. The integration and alignment tests of the mirror modules into the MA will be done in full illumination mode using a large collimated UV beam, with a vertical facility. The facility for the X-ray test and calibration of the MA still needs to be implemented. Ground calibration of the ATHENA full MA raises significant difficulties due to the unprecedented size and mass of the system ([RD3]).

Given the large diameter of the ATHENA MA, an X-ray source at a distance of 120 meter (which is the length of the Panter facility), would only minimally illuminate the optics, producing enormous aberration effects that would prevent from any possible characterization of the PSF and effective area of the telescope (RD3). The low divergence of the beam is needed to guarantee that the HEW errors introduced by the divergence of the beam are kept to a low value. And the beam size needs to be large enough to guarantee that the calibration plan can be achieved within the allocated six (6) months for performing the calibrations.

The conclusions of both the ATHENA TWG and TCWG (RD3) are that, while for full illumination an 800 m beam is required. High costs and significant programmatic issues of this beam facility prompt to look for alternative configurations (RD3).

A calibration facility with an X-ray beam expanded and parallelized by means of an (inverted) X-ray collimator could be a possibility. This solution would remove the exigency of a long beam since full illumination could be achieved by scanning the optics from a short distance with an extremely low divergence. Moreover the compactness of this facility would make possible to perform ground calibration in vertical configuration significantly lessening the impact of gravity release.

Whatever the calibration facility, in order to satisfy the requirements, the main goal of the ATHENA MA calibration campaign will be the observations of a point-like source at different energies in different positions of the FOV with an accurately controlled incident X-ray flux.

Assuming a monochromatic incident flux, from simple statistical considerations, we deduce that several tenths of thousands photons (~40000) are needed at each energy in order fully meet the required PSF modeling. This number is mostly driven by the PSF wings characterization. This number fully meets the required accuracy for the effective area too.

The same goals can be reached with a pure bremsstrahlung continuum spectrum as incident flux, provided that the detector has a sufficient spectral resolution.

In addition to the lower cost and lower beam divergence, such a configuration would have the advantages of allowing local measurements of some of the Mirror Modules (hereafter MMs) and will also allow end-to-end testing of the integrated system MA and Science Instrument Module (SIM) together, since the MA can be placed with the optical axis in a vertical configuration. Moreover with the ATHENA Mirror Assembly mounted in vertical, the deformations due to gravity can be easily compensated by the use of proper actuators, bringing the residual error to less than 1 arcsec. In this proposal, we present the concept of VERT-X, discussing a preliminary configuration and about the implementation of the main subsystems. It should be noted, a similar system at a conceptual level, was proposed by G. Pareschi (INAF-OBA, member of team of proposers) during the ATHENA TCWG meeting of April 2018.

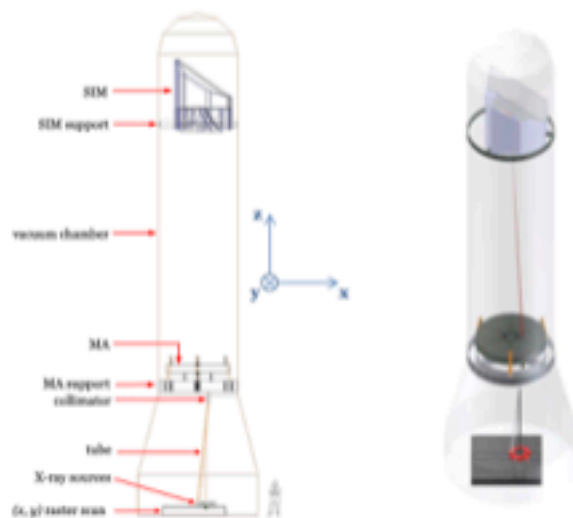

2D frame sketch and 3D conceptual model of the vacuum chamber of the X-ray Vertical Facility (VERTEX), containing the X-ray source, collimator and x-y raster scan stage, the ATHENA Mirror Assembly and the SIM (or the service camera) with respective interface to the vacuum chamber (CREDITS: ESA).

1.1.2 Proposed approach to reach the main technical objectives of the ITT

In order to accomplish the task of accumulating the required number of photons at different energies we are designing an X-ray system which shall guarantee a good collimation combined with an adequate intensity. We have identified as X-ray source a device based on a Bremsstrahlung spectrum radiation, with a temperature 20 keV and a flux of 10^7 ph s^{-1} sr $^{-1}$ flux in 0.2- 12.0 keV energy range. Also fluorescence lines on top of the continuum spectrum, opportunely filtered, can be used for the scope. With the aim of improve source flux distribution and collimation we will use targets < 30 microns, using X-ray sources already available on the market (possibly combined with a pin-hole of a few μ m size, put in the focus of an X-ray collimator, if needed). The collimator will have an effective area of a few square cm, a distance from the X-ray focus in the 1.5-5 m range, and it will produce a parallel beam with divergence < 1.0', an intensity larger than 10 c/s, a size of about 5 mm times 50 mm at the ATHENA optics.

The beam scansion will be able to measure with a good redundancy a PSF with an expected HEW of 5 arcsec for the ATHENA MA and of a few arcsec as foreseen for the single MM.

The vertical optical bench will be based on the following elements:

- ATHENA Mirror Assembly mounted in vertical position inside a vacuum chamber about 20 m high. The focus of the ATHENA optics is placed at the upper end of the chamber. The support of the optics will make use of actuators if needed, in order to subtract the contribution of gravity that would deform the ATHENA Mirror Assembly;
- an X-ray source, with micrometric target and high flux is placed onto a movable X-Y translation stage at a distance of 2-4 m from the optics, in the lower part of the facility. The X-ray source produces a polychromatic isotropic beam via "bremsstrahlung" in the 0.1 – 15 keV range, with the possibility to play with different targets, filters and bias voltage in order to tailor the emission spectra depending on the needs for the calibrations;

- a good quality X-ray optics is used to collimate and widen the X-ray beam. It is based on a parabolic grazing incidence mirror fabricated using a thick substrate (a few cm) in Silicon or glass-ceramic (similar to the grazing incidence systems used to condition the X-ray beams in synchrotron light beam-lines) with a focus of 2-5 m, able to produce at the exit of the pupil a few cm^2 large polychromatic flux with low divergence (1 arcsec). The focus of the X-ray optics corresponds to the position of the X-ray generator target. It should be noted that EUV/X-ray optics to widen and collimate the beam for the calibration of X-ray telescopes have been already studied [18,19] and will be also used in the context of the BEATRIX facility;
- a mechanical system stable and precise, with a good metrological feedback, in order to perform the raster scan with the X-ray beam emitted by the X-ray source and collimated and widened by the grazing incidence parabolic "collimator" mirror with proper accuracy;
- an X-ray detection camera system. It should be noted that a first phase of the calibration of the ATHENA optics will be done using a service camera to be procured ad hoc, having a pixel size at least a factor 3 times lower than the PSF Half Energy Width (5 arcsec) and with a spectral resolution of the order of about 150 eV. In ascend phase a true E2E calibration will be performed with both flight instruments of ATHENA (X-IFU and WFI). In this case the SIM module will be installed at the upper end of the vacuum chamber with the possibility of a proper alignment systems, according to the requirements of the ITT.

One of the key factor to reach the goal of a fully compliant calibration in the assigned time, (independently on the calibration facility) is the detector readout speed which determines the pile-up limit on the input count rate. The detector (with a pixel size $< 0.5''$, a frame time of > 150 frames/s and an energy resolution of ~ 250 eV) can easily read ... c/s per pixel with negligible ($< 1\%$) pile-up. Source and collimator system are mounted on a Semurier truss, a particular clever system for compensation the gravitational deformations. A gimbal system will be used for tilting the truss, in order to make possible off-axis measurements of the ATHENA optics. This system easily allows a scan velocity of 5 mm/s in front of the ATHENA. A metrological equipment will continuously monitor the equipment during the raster scanning operations, allowing us also to close-loop corrections. Moreover the housekeeping data can be used also for post-facto corrections of the position of the focused photons, since both the X-ray service camera and the ATHENA instruments in the SIM will operate in photon counting mode.

Using the service X-ray camera, in 1 day (~ 100 ks) this system can accumulate up to $\sim 10^7$ photons in the relevant energy range scanning the entire MA for a single off-axis position. For each photon, we will have position with $0.5''$ accuracy, arrival time with ms accuracy and energy with < 250 eV accuracy. This dataset will allow a full characterisation of the PSF, according the requirements. The effective area will be measured by comparing the measured flux through the optics with the flux registered in the central aperture, the flat field, for equal interval of times while the scan is done. Since the dimension of the central aperture is very large (80 cm diam) the number of photons registered in the flat field will be the main driver in the statistical error of the effective area. In a few months, the effective area will be measured tens of time, each of one with a good statistical significance for both PSF and Effective Area. Moreover, single MM can be measured in order to get the local performance of the ATHENA MA. E2E test will be also possible using the ATHENA's flight instruments (X-IFU and WFI), a particular important feature for a mission which will perform high resolution spectroscopy and imaging studies.

1.2 First Iteration of Task 1

First iteration of Task 1 allowed the definition of preliminary Product Tree of XRS, shown in

Figure 1-1. For the purpose of this tender the share of responsibilities along the XRS proposed consortium is the following: EIE for the items tree grouped as XRS Housing, MLT for XRS Source and INAF for the XRS service camera. INAF will contribute also with an overall supervision of the entire concept.

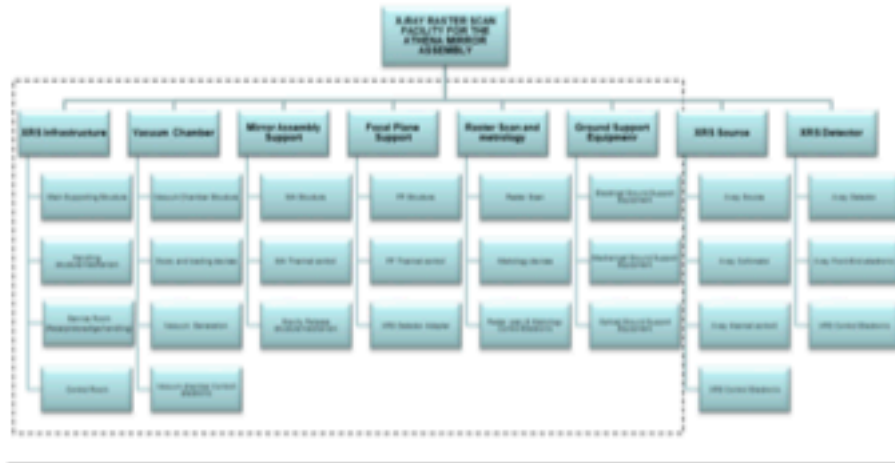

Figure 1-1 XRS Product Tree Ray Source and performances

With respect the ITT conceptual sketch (

Figure 1-1) the product tree is considering a Focal Plane Support in place of SIM. This is the XRS functional element able to detect the radiation localised by the MA on focal plane. The focal plane infrastructure is sized for hosting the SIM as well as the XRS detector, by the means of XRS Detector Adapter. Main goal of the activities shall be the definition of XRS facility able to test the Athena MA by its own detector while MA and SIM combined test capability shall be an option. About the thermal control the assumptions are: MA thermal control a temperature operation at standard laboratory operation by the means of facility equipment, SIM thermal control (option) to be operated by the means of the specific GSE provided by the SIM contractor (facility shall provide the necessary thermal, electrical and mechanical interfaces). About the Gravity Release mechanism the assumption concerns the implementation of a mechanism interfacing with special MA points, to be identified by MA producer in the mechanical interface drawings.

1.3 The Vacuum Tank and the XRS Housing

This section provides a first iteration on the following parts of the vacuum system:

- Vacuum components
- Vacuum vessel
- Thermal plant
- Measuring & Monitoring system
- Control System
- Additional features
- Utilities required

Figure 1-2 shows a Thermal Vacuum Chamber with some of the main components that can be considered as common with the required system. A more detailed description is provided in the following paragraphs.



Figure 1-2: Example of thermal vacuum components (for reference only)

1.3.1 Vacuum Components

Vacuum Components are chosen according to the required vacuum level and the required depressurizing time (10^{-6} torr in 5 hours starting from P_{atm}).

The evacuation is done in two steps, realized by dry primary vacuum pumps and high-vacuum turbo-molecular pumps.

- *Primary vacuum pumps.* In the first evacuation stage, the primary pumps compress the air coming directly from the chamber, reducing the internal pressure from ambient pressure down to approximately 5×10^{-2} mbar.
- *Turbo-molecular pumps.* In order to reach the high-vacuum conditions in the chamber, the vacuum system uses turbo-molecular pumps.
- *Cryogenic pumps.* Cryogenics pumps will work equipped with Helium compressors system.

1.3.1.1 Vacuum Vessel

The vacuum vessel is designed and manufactured in compliance with high vacuum level rules and state of the art for vacuum calculation, components selection, manufacturing process, X-ray verification and leak test.

The vacuum vessel is composed of five elements:

1. The XRS vacuum chamber with its rectangular cuboid shape of 6.4m x 7.0m x 3.5m (LxWxH) with its one access main door.
2. The MA vacuum chamber with its cylindrical shape of 4.2m x 3m (\emptyset xH) with its one access door.
3. The intermediary vacuum chamber with its cylindrical shape of 4.2m x 8.6m (\emptyset xH), no door.
4. The SIM vacuum chamber with its cylindrical shape of 4.2m x 5.4m (\emptyset xH) removable top included.
5. The vacuum vessel support structure

Without its support structure, the entire vacuum vessel shows at this level of study, a base of 6.4m x 7.0m, a height of 20.5m and a weight of 70T.

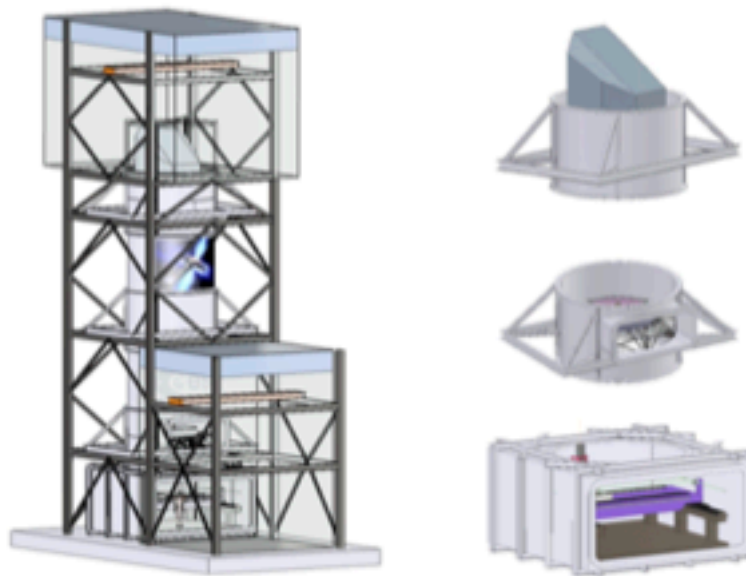

Figure 1-3: Configuration of the vessel after the first iteration. The grey volumes on the left represent the ISO-5 clean rooms.



Figure 1-4: Example of primary vacuum system (for reference only)



Figure 1-5: Example of turbo vacuum system complete of gate valves and backing line (for reference only)



Figure 1-6: Example of cryogenic vacuum system complete of helium compressors and electrical cabinets (for reference only)



Figure 1-7: Example of vertical sliding door complete of automation system for opening/closing (for reference only)



Figure 1-8: Image for refer. only: example door on the top of the vessel for positioning of the DUT.

1.3.1.2 Thermal Components

In order to guarantee the performances required in terms of temperature distribution, temperature uniformity, and temperature variation ($^{\circ}\text{C}/\text{min}$) during the test on the test object (i.e. near/around the MA, around the X-ray source and the Collimator, and around the SIM) we propose:

- Shroud technology with liquid nitrogen (LN_2) for the performance tests, and chilled water for stabilization tests (to be defined in a later phases).
- Thermal plate in case conductive heat transfer is required.
- Advanced specimen thermoregulation technology and high temperature homogeneity (if needed).

1.3.1.3 Measuring and Monitoring System

Both the Vacuum and Thermal systems will be equipped with all the sensors for measuring and monitoring the system, and all the additional sensors needed by the customer.

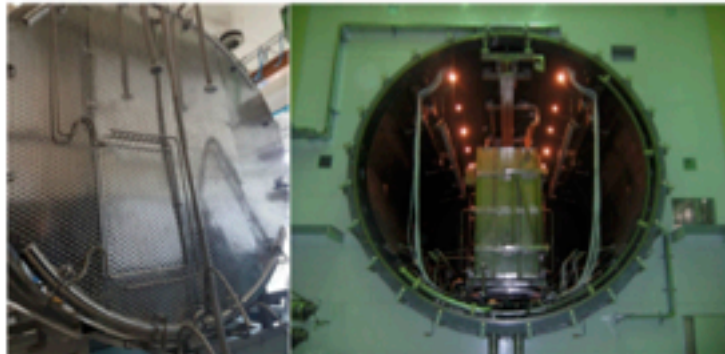

Figure 1-9: Image for reference only: example of thermal shroud

1.3.1.4 Control System

The chamber includes a PLC (Programmable Logic Controller) based control system, used to manage individual subsystems. Sequencing, safety interlocks, and operator interfaces are implemented through the

PLC. In case of failure of utilities such as power, pneumatic supply, cooling water, etc., PLC software provides built-in inter-subsystem interlocks to ensure the safety of operating personnel, test object, and facility equipment.

HMI devices are provided for local (local panel) and remote (PC Winratos software) control connected to the PLC.

1.3.1.5 Additional Features

The details of the thermal vacuum system will be defined and designed during the Engineering & Design phase. In any case, a short list is provided below:

- Vibration insulation. If required, it is possible to supply bellows and similar damping systems between the thermal vacuum system and the seismic mass (if any).
- Cleaning. The chamber is intended to be installed in an ISO5 cleanroom. Cleanliness and contamination control will be carried out according to ECSS-Q-70-01-C.

1.3.1.6 Utilities

The vacuum chamber design will include all the auxiliary systems for the chamber operation — i.e. compressed air, chilled water, nitrogen (LN2 and GN2) and power — considering also the availability on site. The preliminary power budget is: 3ph+N+PE, 400V/50 Hz, approximately 250 kW.

1.3.2 Raster scan mechanism

1.3.2.1 General description

Figure 1-10 shows a 3D view of the raster scan with the main components highlighted. The machine can be divided into two logical parts:

1. The lower part from the Base to the Gimbal mount, which is thought to bear, position and orient the X-ray beam with the required accuracy. The main elements of this part are the four motion axes that translate and rotate the beam (see below).
2. The upper part with the Semurier truss carrying the X-ray source and collimator (i.e. the X-ray beam). This part is thought to be as rigid and light as possible: rigidity maintains the alignment between X-ray source and collimator, while lightness simplifies the work of the underlying motion axes. The Semurier scheme helps in maintaining the source-collimator alignment under gravity (see sec. 1.3.2.3).

The raster scan has four axes to position and orient the X-ray beam:

- Translation along Y: the bridge moves over the base.
- Translation along X: the trolley moves over the bridge.
- Rotations around X and Y: the Semurier truss rotates inside the Gimbal mount.

Every axis is defined by three elements: the bearing (which constrains every DOF but the desired one), the motor (which provides the motive force), and the encoder (which feedbacks the current position to the control system). Sections 1.3.2.2 and 1.3.2.3 describe the setup of the four axes in detail.

The Semurier truss hosts two high-precision tiltmeters to measure the attitude of the X-ray beam w.r.t. the gravity vector. During the experiment, the signal of the tiltmeters is used to correct the X-ray beam orientation, bypassing the encoders of the Gimbal mount. Sec. 1.3.3 describes the tiltmeters setup and operating procedure.

1.3.2.2 Base, bridge, and trolley

The Base is the fixed part of the raster scan, the one supporting the translating bridge. It shall lay on the rigid points of the vacuum vessel, in such a way to discharge the loads properly. Two alternatives hold:

1. Granite table, which has high stiffness and high vibration damping capabilities.

2. Stainless steel, which grants good stiffness with lower weight. It is also easier to interface with the vessel.

The granite is the baseline for this tender, because it is typically used for the surface plates and high precision bases. However, a trade-off will be carried out in the preliminary design phase.

The Bridge is the first moving part of the raster scan (translation along X). It slides over the Base and it hosts the linear guides for the Trolley. The Bridge translation axis has the following mechanisms:

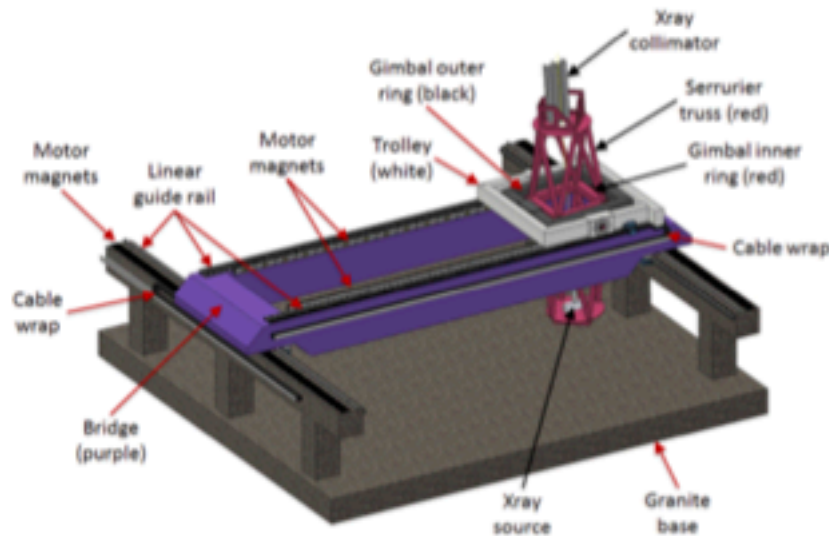

Figure 1-10: 3D view of the raster scan with the main elements highlighted.

- Two high-precision linear guides (one per side, e.g.: THK model HSR 35 LAM).
- Two or four motors. The motors can be linear drives or rack-and-pinion. In the former case, either one or two motors per side can be used; EMC compatibility with ATHENA shall be investigated. In the latter case, two counter-acting motors per side shall be adopted in order to avoid backlash; more attention shall be paid to lubrication issues. The baseline for this proposal are two linear drives per side (for instance, ETEL model LMS20-100).
- Two encoders (one per side). The baseline are the linear absolute optic encoders from HEIDENHAIN.

As it regards the materials, either stainless steel, aluminium, or carbon fibre can be used. As per the Base, a trade-off will be carried out in the preliminary design phase. In case carbon fibre is chosen, its outgassing properties shall be compliant with ATHENA requirements.

The baseline for this proposal is stainless steel, because it is easy to manufacture and provides high stiffness. We underline that the Bridge moves horizontally with low accelerations, thus mass is a second-order issue.

The Trolley is the second moving part of the raster scan (translation along Y). It slides over the Bridge and it constitutes the fixed part of the Gimbal mount. The Trolley translation axis has the following mechanisms:

- Two high-precision linear guides (one per side, same model as the Bridge linear guides).
- Two or four motors. The motors can be linear drives or screw drives. The baseline for this proposal are two linear drives per side (ETEL model ILF15-050).

- Two encoders (one per side). The baseline are the same encoders as per the Bridge (linear absolute optic encoders from HEIDENHAIN).

As per the Bridge, either stainless steel, aluminium, or carbon fibre can be used. The baseline for this proposal is stainless steel (as the bridge, also the Trolley moves horizontally, thus mass is not that important).

Figure 1-11 shows two detailed views of the Bridge mechanisms (translation along X) and of the Trolley mechanisms (translation along Y). Power and data will be carried from the Base to the Bridge and from the Bridge to the Trolley through cable wraps or festoons.

The mechanisms — linear guides, encoders, and linear drives — shall stay next to one another in order to close the control loop (bearings – sensors – motors) in an as short as possible span. The proposed concept accomplishes this fundamental requirement, but the possibility that the mechanisms sit on a machined plate endowed with adjusting devices will be explored during the design. Full compliance with baking procedure shall be analyzed.

1.3.2.3 Gimbal mount and Serrurier truss

The Gimbal mount allows the Serrurier truss (which carries the X-ray beam) to rotate around the X and Y axes. Technically, the Gimbal is a Cardan suspension with the two rotation axes converging on the same point, which prevents the Serrurier axis to offset while rotating.

In order to have the Gimbal perfectly balanced, the centre of rotation shall also be the centre of gravity of the Serrurier truss. Possible unbalances will be corrected by dedicated counterweights.

The Gimbal rotation axes have the following mechanisms:

- High-precision bearings. See sec. 0 for the potential problems and the foreseen trade-offs on the Gimbal bearings. The baseline is Timken ball bearings model 5HAR110-P7, which is angular-contact type in martensitic stainless steel, to be assembled with ceramic balls and phenolic cage, precision class ABEC 7.
- Direct motors. A possible solution is provided by the ETEL model TMB+175-70.
- Rotating optic encoder from HEIDENHAIN.

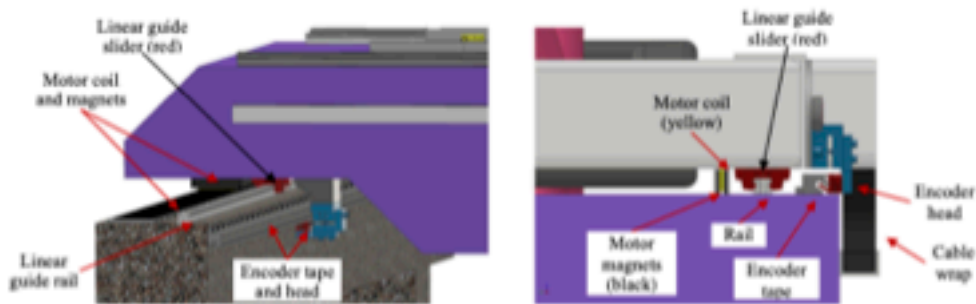
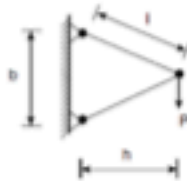

Figure 1-11: Bridge mechanisms (left) and Trolley mechanisms (right).

The Serrurier truss maintains the alignment between the X-ray source and the X-ray collimator under the action of gravity, provided that the two platforms with the X-ray devices are rigid enough w.r.t. the truss hinges. In first approximation, the deflection of the truss vertex due to gravity is given by (see Bely, The Design and Construction of large Optical Telescopes, Springer, 2003 , sec. 6.4.1, eq. 6.3):

$$\delta = \frac{2Pl^3}{EAb^3} = \frac{2Pl^3}{EAb^3} \left[\frac{b^2}{4h^2} + 1 \right]^{3/2}$$



Preliminary calculations show that the source-collimator misalignment due to gravity is on the order of 0.2 arcsec, even without an optimized Serrurier design. Please note that this value is completely repeatable, thus a pointing model similar to those built for the telescopes can compensate for it.

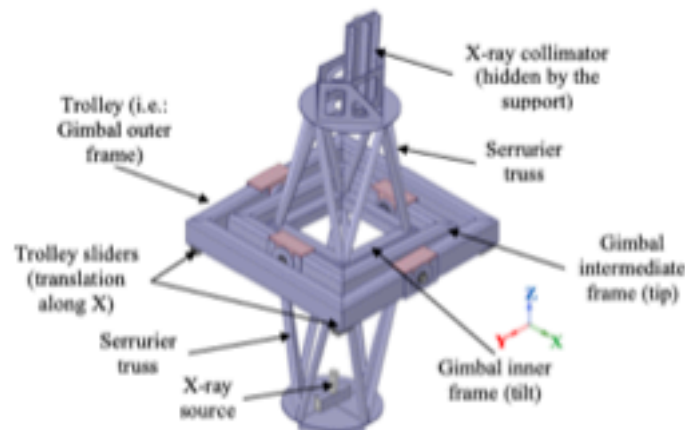

Figure 1-12: Gimbal mount and Serrurier truss with the X-ray source and the X-ray collimator.

Figure 1-12 shows the Gimbal mount and the Serrurier truss with the X-ray beam and the X-ray collimator. The Serrurier truss is rotated by 3 deg on both axes to show the maximum operative incline of the Gimbal.

Figure 1-13, instead, shows the detail of the Gimbal shaft, with the bearings, the motor, and the encoder highlighted. It is only a concept, which shall be corrected on the base of functional, manufacturing, and assembling considerations.

As per the Bridge and the Trolley, either stainless steel, aluminium, or carbon fibre can be used. On the contrary of the Bridge and the Trolley, the Gimbal and the Serrurier rotate during the functioning, thus their mass — or better their inertia — has great importance. The baseline for this proposal is stainless steel.

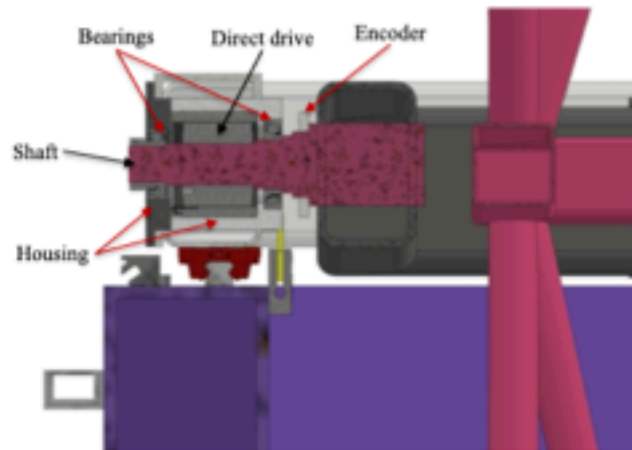

Figure 1-13 Shaft section of the Gimbal mount (concept only).

1.3.3 Tip/tilt metrology

1.3.3.1 General Requirements

The metrology based on the tilt-meters uses the gravity vector as an absolute reference for the orientation of the Serrurier. An optical metrology system shall rely on a different reference. In general, the metrologic problem consists in monitoring the orientation of the Serrurier while the raster scan is in operations. In telescopes technology, we distinguish between a pointing phase and a tracking phase. In pointing, the system is commanded to reach a certain position in the sky, while in tracking it is commanded to follow that position while the celestial body moves because of the Earth rotation. In the XRF case, the operator who wants to perform measurements along a certain direction of the field of view of ATHENA commands the Serrurier to reach the respective pointing direction. The pointing position is defined at the beginning of the operations and it shall be kept fixed while the raster scan moves along the working area. The tracking procedure in this case consists in keeping that defined pointing direction while the trolley moves along the working area. The pointing direction is reached by using the information provided by the encoders to control the motion of the Serrurier, the inclinometers or the optical metrology are not used to this purpose. Any attitude variation of the trolley have a direct impact on the encoders, so the encoders are blind to this attitude variation: during tracking then the metrology shall measure the offsets relative to the pointing direction and its outputs are used to correct the orientation of the Serrurier.

We are interested in monitoring only the orientation around the X and Y-axis: although the X-ray collimated beam is elongated along a certain direction, so that a rotation around the Z-axis would have some impact on the measurement performed at the MA level, we consider negligible the contribution of the mechanics to such rotation.

The mechanical operating principle of the Serrurier is that the flexure occurring at its top part and that occurring at its bottom part are identical, so that the collimation is maintained. We make here the assumption that the compliance of the Serrurier to such ideal behavior is first checked by analysis, and second it is verified on the as-built structure, using a temporary metrology set-up that verifies that (1) the collimation error is kept within the requirement and (2) any gravity-induced rotation of the structure is negligible.

We also make the assumption that, once the Serrurier compliance is verified in that way, the normal operating principle of the system does not require to actively monitoring the entire structure. In other words, the development of the Serrurier structure shall be such to guarantee that, with respect to the rotations, the system deforms in such a way that it behaves like a rigid body to the purpose of the tip/tilt metrology; this assumption is justified by the preliminary FEM results (see §1.3.5.2). Consequently, any rotation induced by the trolley used to move it along the working area is directly imparted to the whole Serrurier structure, and we are free to select the point where the rotation measurement shall be done. From the point of view of the motion control system, the closer to the motor, the better.

A practical implementation of the tip-tilt metrology consists in the usage of tiltmeters. A different approach makes use of an optical metrology based on an autocollimation system. This paragraph describes both approaches.

1.3.3.2 Tiltmeters

The tilt-meters are mounted on the Serrurier truss at the level of the Gimbal mount inner frame (see Figure 1-12). They measure the attitude of the Serrurier truss (i.e. of the X-ray beam) w.r.t. the gravity vector, in order to correct it by acting on the Gimbal mount. As stated above, this means that during the experiment the Gimbal encoders are bypassed and the tiltmeters signal only is used.

See sec. 0 for the potential problems and the foreseen trade-offs on the tiltmeters. The baseline for this proposal is the electrolytic tiltmeter Jewell 755-high-gain (Figure 1-14, left), which has a range of ± 0.5 deg, a resolution of 0.02 arcsec, a repeatability of 0.2 arcsec, and a time constant of 0.5 s. This means it cannot face the whole operative range of the raster scan (± 3 deg), but it shall be used with the following procedure:

- One tiltmeter is mounted directly on the Serrurier truss. This tiltmeter is referred to as "fixed tiltmeter" and it faces the whole incline of the Serrurier truss.
- A second tiltmeter (referred to as "mobile tiltmeter") is mounted on the top of two servogoniometer in series. The two goniometers can recover any initial incline of the Serrurier truss, in order to

maintain the tiltmeter horizontal within a certain tolerance. Figure 1-14, right provides an example of commercial goniometer.

- STEP 1: the fixed tiltmeter initializes the machine by aligning the Serrurier with the gravity vector (tolerance of 0.2 arcsec).
- STEP 2: the Gimbal encoders tilt the Serrurier to the right incline for the experiment. At the end, the Serrurier has the required orientation with an error given by the initial tolerance (0.2 arcsec) plus the encoder offsetting error (which is small, being the angle small).
- STEP 3: while the Serrurier moves, the servogoniometers counter-move the mobile tiltmeter with an opposite command, in order to maintain the tiltmeter horizontal. At the end, the fixed tiltmeter is as sloped as the Serrurier (possibly out-of-scale), but the mobile tiltmeter is horizontal within the goniometers tolerance (in the order of many arcsec).
- STEP 4: the goniometers are locked in the horizontal position, and the experiment can start. The orientation of the mobile tiltmeter is the new zero for measuring the Serrurier $\Delta p/\Delta t$ variations during the test.

With this procedure, Serrurier orientation is the nominal one within the tiltmeter accuracy plus the encoder offsetting error (ca. 0.2 arcsec), while the deviation from the initial orientation is measured with the tiltmeter accuracy (0.2 arcsec) and resolution (0.02 arcsec).

The key step of the procedure is the blockage of the servo-goniometers, which can be done either mechanically or through the control system. Blockage accuracy is not important (it must be small w.r.t. the tiltmeter range of ± 0.5 deg), but stability is: goniometers instability becomes directly alignment error without possibility of compensation.

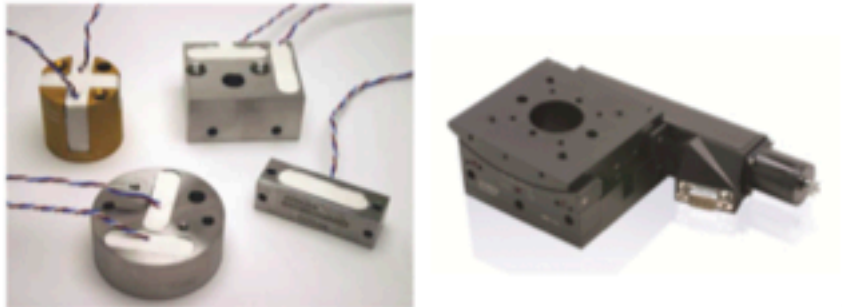

Figure 1-14 Left: Jewell electrolytic tiltmeters series 755 and 756. Right: example of commercial servogoniometer (PI model WT-85).

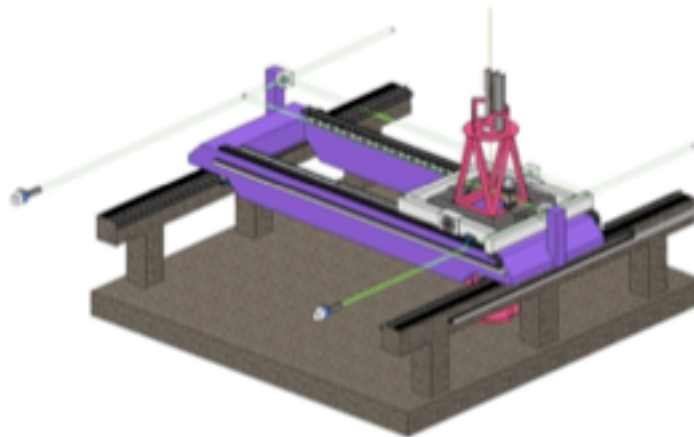

Figure 1-15: Image for reference only: example of a potential implementation of the optical metrology for attitude determination in autocollimation. The pentaprisms are represented by cubes for simplicity.

1.3.3.3 Optical metrology

The optical metrology shall be able to measure the rotations of the Serrurier during tracking, so the optical train shall be configured in such a way to follow the motion of the raster scan. We consider here an implementation based on the usage of a high precision autocollimator, mounted externally to the vessel on a separated basement. Any rotation shall be referenced to a reference system with the origin at the center of the field of the autocollimator, one axis normal to the detector plane passing to its center, and the other two axes lying on the detector plane, with one of them directed along the local vertical.

The autocollimator sends the beam towards a direction parallel to the X-axis of the raster scan. A pentaprism installed on the bridge folds the light by 90 degrees along the bridge and towards the trolley. Attached to the trolley there is a mechanical structure hosting a second pentaprism which folds the light again along a direction parallel to the X-axis and towards the Serrurier. Attached to the Serrurier there is a flat folding mirror installed on a two axis tip-tilt stage (it can be either gimbal or kinematic). The light reflected by the mirror is sent back to the autocollimator as a reference to measure the stability of the orientation along rotations occurring around an axis parallel to the X-axis and passing through the center of the mirror. A similar configuration is used to measure the stability of the attitude along a rotation axis parallel to the Y-axis, but in this case it is necessary only one pentaprism to fold the light towards the correct direction.

We discuss in the following two main issues affecting the performances of this metrology. First, once the trolley moves along the bridge, or while the bridge itself moves along its linear guides, the trolley attitude changes (which is exactly the reason why we have to implement a metrology system). As the pentaprism are rigidly attached to the bridge and to the trolley, any rotation of them affects also the respective pentaprism, deflecting the incoming beam in such a way to mimic an attitude variation of the Serrurier. Nevertheless, pentagon prisms are ideally suited for deflecting the beam of an angle measuring device by 90 degrees as the deflection angle is subject to only second-order error influences in the presence of angular errors in the orientation of the prism. We call "roll" any rotation of a pentaprism around the axis of the incoming beam, and "yaw" any rotation around the axis of the outgoing beam. Geckeler [Proc. SPIE 6293 (2006)] reports the sensitivity of slopes measurements to the roll and yaw angles of the pentaprism, leading to a slope error of ± 0.03 millarcsec / arcsec.

The attitude measurement around X-axis requires the usage of two pentaprisms along the optical train, while the rotations around the Y-axis require only one. Hence, in the first case the contribution to the measurement error due to misalignments of the pentaprisms is about 0.06 milliarsec / arcsec, while in the second case it adds to about 0.03 milliarsec / arcsec. The measurement accuracy of an ELCOMAT 3000 autocollimator system is 0.1 arcsec (one sigma), within any angular range of 20 arcsec and working on a distance of 20m. The preliminary results of the FEM analysis reports a flexure of about 4 arcsec (this value includes flexures due to the bridge, the trolley and the Semurier), i.e. within the range where the error of the autocollimator is specified.

At the edge of the error range, the added error due to the pentaprisms is < 0.002 arcsec and < 0.001 arcsec, for the measurement of the rotations around X-axis and Y-axis, respectively. The conclusion is that the measurement accuracy on a tilt as large as 20 arcsec (five times that expected) will be affected by an error of about 0.102 arcsec (X-axis) and 0.101 arcsec (Y-axis). The real error is likely to be smaller, as the working distance is less than half that for which the error of the autocollimator is reported, and the rotations of the pentaprisms, used to perform this first iteration, are overestimated by a factor of five, with respect to the preliminary results of the FEM.

A further point worth mentioning is about the tip-tilt mount of the mirrors. The presence of this sub-system is of course related to the necessity to keep the orientation of the mirrors within the measuring range of the autocollimator, which is far below ± 3 degrees required on the achievable orientation of the Semurier. We remark once more that the purpose of the metrology is to track any possible variation of the pointing direction due to the mechanics while the trolley moves in the working area. The possibly filtered metrology measurements are inputs to the control system, to drive the motors and recover the correct orientation. It is then not necessary to have a very accurate tilting system to recover the orientation of the mirrors: it just have to bring back the mirror to a configuration compatible with the measuring range of the autocollimator, and this can be achieved with a positioning accuracy of several arcsecond, achievable even by commercial, vacuum-compatible tip-tilt platforms.

The real issue is about the stability of the tip-tilt mount once it completed the motion: we might expect that some noise occurs, depending on the characteristics of the actuators and the mechanical configuration of the assembly. This issue shall be addressed in more detail during the design phase, by both collecting information directly from the vendors or by moving towards a custom design, which might also include for instance a hard stop that enters into function once the motion of the mirror finished.

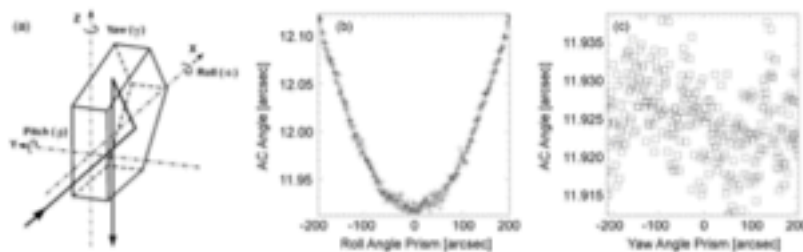

Figure 1-16: (a) Pentagon prism and the deflected measuring beam. (b) Dependence of the angle measured with the autocollimator on the roll angle of the prism. (c) Angle measured as a function of the yaw angle of the prism [from Geckeler, R.D. "Error Minimization in High-Accuracy Scanning Deflectometry", Proc. SPIE Vol. 6293 (2006)]. The error dependence on pitch angle is zero up to second order.

1.3.4 Control system

1.3.4.1 Overview

The interaction with the XRS Facility Control System will be done publishing an OPC-UA domain located in the network connecting the systems.

OPC Unified Architecture is a communication protocol developed by the OPC Foundation. Its scope is to provide a technology agnostic Machine to Machine (M2M) communication. The protocol is suitable for real time and low latency systems, because it defines a binary protocol.

Since OPC-UA is technology agnostic, server and clients can be implemented using any programming language. Different implementations and product can be already found on the market both in commercial and open source worlds.

The global network architecture can be compared to a hierarchical automation technology communication network. At the highest level there is the XRS Facility Control system communicating with the Subsystem Supervisor using OPC-UA protocol.

The Sub-systems supervisor will be responsible for the following main tasks:

- Single point of access: provide a unique and consistent interface to the external world, allowing the full control of every Subsystem functionality. The only connection needed by an external user for normal operations is with the Sub-systems Supervisor
- Orchestration: the Sub-systems Supervisor is responsible for keeping track of the status of every subsystem, and for implement macro functions which may need to operate a group of subsystem in the correct order.

The Sub-systems Supervisor, in turns, communicates with the Industrial PCs that have to control all the machine functionalities:

- The XRS Control System (XRCS) is responsible for the movement of the bridge along its rail, of the trolley along its rail, Gimbal outer ring around its axis and Gimbal inner ring around its axis.
- The XRS Monitoring and Auxiliary Control System (XRMACS) that has to fetch and publish the telemetry: temperature data, crane status, interlock status
- Building Management System (BMS)
- Vacuum Vessel, thermal control (ThCS)
- Vacuum Vessel, pneumatic circuit Mirror Assembly Cart (MACS)
- Science Instrument Module Cart (SIMCS)
- Detector Positioner (DPCS)
- Metrology

The communication between the Industrial PCs and the field will be based on the EtherCAT protocol, which guarantees the following requirements:

- hard real-time: fast cycle times (sometimes within μ s) and precise synchronization
- standard Ethernet cabling, cost effective components
- Master-Slave & Slave-Slave Communication

The connection between the two industrial PC will be implemented with EtherCAT Automation Protocol (EAP), and will guarantee the following requirements:

- soft real-time: no strict requirements regarding cycle time and synchronization, cycle time in the range of milliseconds
- standard Ethernet infrastructure components
- master-master communication

Where a faster communication is needed, a TTL interface to exchange information can be provided.

1.3.4.2 Control HW

The Sub-systems Control System hardware will consist of:

- The various sensors that detect the enclosure status, such as encoders, contact and end switches, flow and temperature sensors, etc. EIE will define a comprehensive measurements plan of all status and input signals.
- All electrical drives, valves, etc. which drive the motion mechanisms and the thermal control systems (if applicable).

1.3.4.3 Interfaces

The Sub-systems Control System communicates with the Sub-systems supervisor using the LAN.

EIE will design and supply the software interfaces for communication between the control units, i.e. the software that sends commands and publishes the telemetry from the Industrial PCs.

The communication protocols have to be agreed together with the Customer.

1.3.4.3.1.1 General Requirements

In general a sub-system will process the following input:

- Signals from the sensing devices.
- Commands and queries from the Sub-systems Supervisor.

The output will generally consist of:

- Status data as queried by the Sub-systems Supervisor.
- Signals to the hardware units (motors, heat exchangers, etc.)

The following general requirements will apply to the control software:

- All relevant signals (voltage levels, currents, switch positions, temperatures etc.) must be available as input signals for the Industrial PCs and available in the sw interfaces for upper level.
- All moving or adjustable devices will be available for individual, independent movement (adjustment) for test and maintenance purposes.
- There will be software checks to prevent a requested operation from being done if not safety-compatible with the subsystem status.
- Each Sub-system Control System has to take the equipment to a safe state in any error, emergency or dangerous situation. All the interlocks and emergency signals and the resulting machine status will be documented as a part of the sw interface and of the Engineering Graphic User Interface.
- All possible failures that the software can detect will also be handled by the software, which will bring the system to a safe and well-defined state.
- There will be an in-depth failure analysis during the design phase, identifying and describing failures and actions when detected.
- EIE will produce a list of errors, alarms and warnings (potential alarm situations) reported by the subsystem. The list will contain all that the software can detect in terms of malfunctions (in software and hardware). There will also be a help text for each entry in the list, describing the reason and recommended action.

1.3.4.3.2 Interlocks

Hardware interlock systems will be foreseen to:

- Prevent Sub-Systems movements when locked.
- Fulfill the safety requirements

1.3.5 Preliminary calculations (FEM model)

In order to check the consistency of the proposed concept, a FEM model of the Raster Scan has been set up and used to calculate the vibrating modes and the deflection under gravity. Figure 1-17 shows a 3D

view of the Raster Scan FEM model, while Table 1-2 reports the model main facts. The model has been built in Ansys.

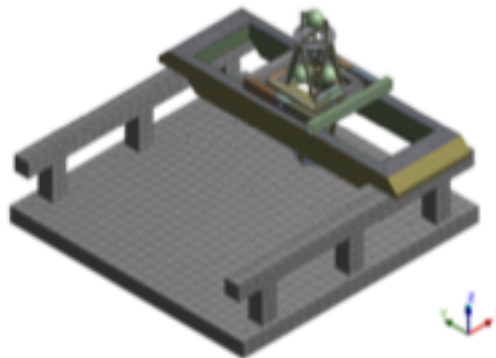

Figure 1-17: 3D view of the FEM model.

Table 1-2: FEM model main facts.

Issue	Description
Elements	Solid elements for the granite base; beams for the Gimbal shafts and the Serurier truss; point masses for the collimator and the Xray source; shells for all the other components (Bridge, Trolley, Gimbal, plates of the Serurier).
Material	Isotropic linear elastic. Only density, Young modulus, and Poisson ratio are relevant. For the granite: $\rho = 2600 \text{ kg/m}^3$, $E = 40 \text{ GPa}$, $\nu = 0.25$. For the stainless steel: $\rho = 8525 \text{ kg/m}^3$ (10% safety margin), $E = 193 \text{ GPa}$, $\nu = 0.31$.
Linear guides	Modelled as springs. The stiffness is provided by the supplier: vertical 450 kN/mm, lateral 450 kN/mm, torsional 1160 Nm/deg (all rotations).
Linear motors	Modelled as rigid connections in the direction of motion.
Gimbal bearings	Modelled as springs. The stiffness is provided by the supplier: radial 110 kN/mm, axial 30 kN/mm.
Gimbal motors	Modelled as springs with very high stiffness (10^7 Nm/deg) acting only in the direction of motion (the rotation around the axis of interest). The spring has been calibrated in order not to affect the vibrating modes, approximating a rigid connection. This is to model rotating motors in a similar way to linear motors despite software limitations.
Encoders	Not modelled (no servo analysis if performed for this offer).

1.3.5.1 Vibrating modes

Figure 1-18 and Figure 1-19 show the first four vibrating modes of the Raster Scan. The Trolley is set in an unbalanced and rotated position to catch possible asymmetric phenomena.

The following considerations apply:

- Natural frequencies are pretty high, even if it is only a concept design. In particular, natural frequencies are higher than the probable forcing on the structure — mainly the guideline shape errors and the bridge bending during the X-Y motion (see below).
- The first two modes are the rotations of the Serurier around the sp/SR axes. Contrary to what it may seem, the two modes are not due to the rotating motor springs (which are calibrated to act as rigid connections, see Table 1-2), but to the compliance of the inner Gimbal ring. This is evident in Figure 1-20: the inner Gimbal coloured in red shows it is the part that contributes the most to the

vibrating mode. In order to increase natural frequencies, a revision of Gimbal intermediate and inner rings is to be performed.

- A change of material from steel to aluminium is likely to have only minor effects on the vibrating frequencies (the Young modulus to density ratio is similar). Instead, a change of material to carbon fibre is likely to increase the frequencies, since the Young modulus to density ratio is higher. On the other hand, carbon fibre poses many technological issues (first of all, the outgassing) that steel and aluminium do not.

As stated above, the main forcing on the structure are the linear guides shape errors and the bridge bending during the X-Y motion. It is important that the natural frequencies of the structure are far above all the significant forcing components (meaning all the forcing harmonics with a strong energy content): if this condition applies, the control system can act at the frequencies of the forcing to compensate for the beam misalignment without injecting energy to the structure vibrating modes, which would cause resonance and instability phenomena. This means that — in case the frequency separation condition applies — the control system closes the control loop more easily and more effectively.

The following apply:

- The bridge bending has a characteristic wavelength equal to the bridge span (4000 mm) with no significant higher-order harmonics.

The linear guides shape error has a characteristic wavelength in the order of 250 mm, but measurements provided by the supplier show there are significant components up to the 25th harmonic.

Considering a scanning speed of 10 mm/s, the forcing has an upper significant frequency in the order of 1 Hz (linear guides, 25th harmonic), which is far below the first natural frequency of the structure (ca. 20 Hz).

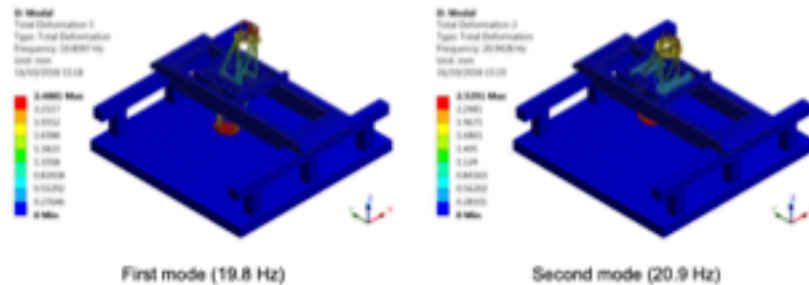

Figure 1-18: First and second vibrating modes.

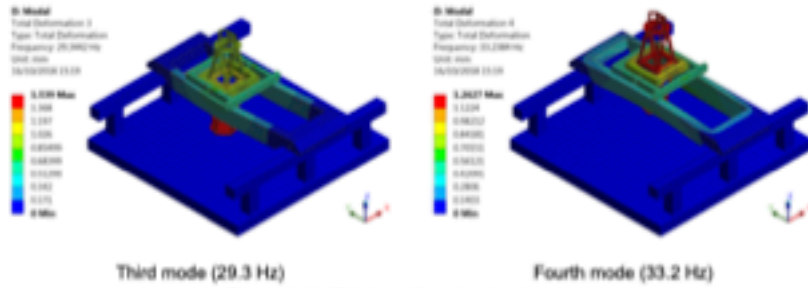

Figure 1-19: Third and fourth vibrating modes.

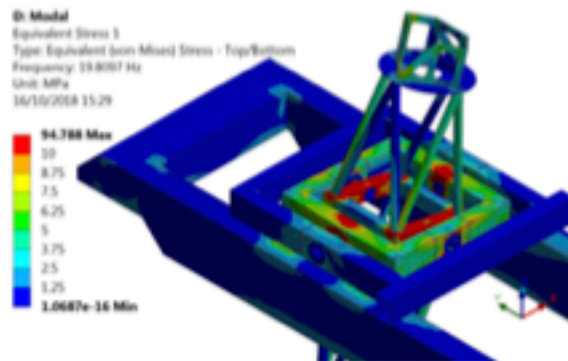

Figure 1-20: First mode (19.6 Hz), von Mises stress. Note the high relative stress on the inner Gimbal ring (coloured in red).

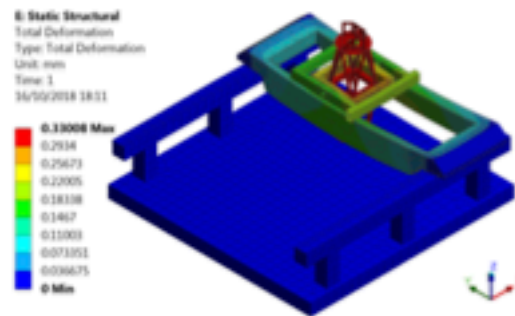

Figure 1-21: Total deformation (mm) due to gravity.

Based on this first iteration, the system does not present criticalities for the development of the control system, which is likely to be able to control the beam attitude without particular interaction with the structure. In the course of the activities a complete servo analysis will be performed in the design phase. Paragraph 1.1.3.2.6.4 will discuss in more detail the way we usually approach the development of the control system design.

1.3.5.2 Deformations due to gravity

Figure 1-21 shows the total deformation of the structure due to gravity, while Figure 1-22 shows the corresponding rotations around axes X and Y.

Rotations around axes X and Y are important because tiltmeters and optical metrology measure these quantities (see sec. 1.1.3.2.4). More precisely, the tiltmeters and the optical metrology are sensitive to the variations of X and Y rotations while the Trolley and the Bridge move.

Because of this, calculations has been performed with the Trolley in three positions along the Bridge (central, intermediate, and extreme; the intermediate being the one shown in the figures above). Table 1-3 and Table 1-4 report the results, respectively for the rotations around X and Y.

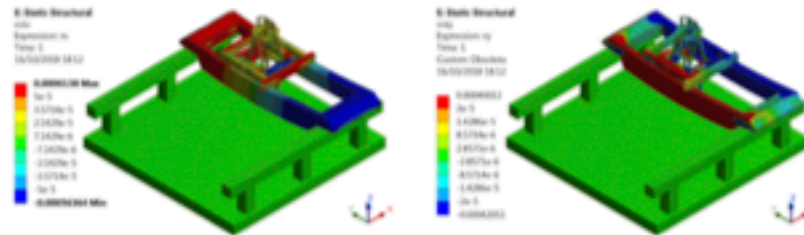

Figure 1-22: Rotations around X (left) and Y (right) due to gravity. Values in rad.

Table 1-3: Variation in rotation around X axis of the collimator, the source, and the metrology mirror during the motion of the Trolley. Values in arcsec.

Unit	Extreme to Intermediate Trolley position	Extreme to Central Trolley position	Intermediate to Central Trolley position
Collimator	-4.94	-9.76	-4.81
Source	-4.94	-9.75	-4.81
Optical metrology mirror 1	-4.87	-9.60	-4.72

Table 1-4: Variation in rotation around Y axis of the collimator, the source, and the metrology mirror during the motion of the Trolley. Values in arcsec.

Unit	Extreme to Intermediate Trolley	Extreme to Central Trolley position	Intermediate to Central Trolley position
------	---------------------------------	-------------------------------------	--

	position		
Collimator	0.12	0.16	0.05
Source	0.12	0.16	0.05
Optical metrology mirror 2	-0.32	0.1	-0.22

Because of this, calculations has been performed with the Trolley in three positions along the Bridge (central, intermediate, and extrema; the intermediate being the one shown in the figures above). Table 1-3 and Table 1-4 report the results, respectively for the rotations around X and Y.

The following considerations apply:

- Even if it is only the first design attempt, the Serrurier truss works well, because Collimator and Source undergo similar variation in rotation during the Trolley motion.
- Because of the Gimbal configuration, X rotations depend mainly on the stiffness of the intermediate Gimbal ring, while Y rotations depend mainly on the stiffness of the inner Gimbal ring.
- Since rotation X of mirror 1 (the one for measuring X rotations) has a similar trend as the Collimator and the Source (Table 1-3), the intermediate Gimbal ring is stiff enough and do not influence the overall performance of the structure.
- On the contrary, since rotation Y of mirror 2 (the one for measuring Y rotations) has different trend than the Collimator and the Source (Table 1-4), the inner Gimbal ring is not stiff enough and it is detrimental for the overall performance of the structure. This is the same result as the modal analysis (see the previous section).

With proper optimization of the Gimbal mount — in particular with proper stiffening of the inner ring — it is likely that also rotation around Y will have similar paths between Collimator, Source, and Gimbal. This means that tiltmeters and metrology mirrors can be placed indifferently next to Collimator and Source or on the Gimbal inner ring, and they would provide similar readings. The latter possibility (mirrors on the Gimbal ring) is by far the simplest, and it is the one described in sec. 1.1.3.2.4.

1.3.5.3 Deformations due to linear guides shape errors

No calculations have been performed in this tender phase on deformations due to other forcing, including the linear guides shape errors.

As it regards rotations at the level of tiltmeters and metrology mirrors, the configuration of the Gimbal mount — thanks to the two perpendicular rotation axes — prevents transmitting any rotational deformation of the outer ring to the inner one. This consideration reinforces the statement above that tiltmeters and metrology mirrors can be placed indifferently on the Gimbal inner ring or next to Collimator and Source, which was previously based only on gravity calculations.

Of course, during the design phase detailed calculations will be performed with all the significant forcing. A trade-off will also be performed on the Gimbal bearings to detect the best mounting option (if blocking all the degrees of freedom but the axis rotation, or if blocking only the translations leaving the axis free to tip and tilt within the bearings housing). See sec. 1.2.3.1 for other trade-offs on the Gimbal bearings.

1.3.5.4 Servo analysis

A detailed servo analysis of the motion system will be developed in the course of the activity. In the following we outline the main guidelines for the realization of the control design.

The servo analysis gives the possibility to estimate the behaviour of the system in terms of performances, structural vibrations and help to design the control law starting from PID controller to maximize system responsiveness and implement filtering techniques to minimize system vibrations (low-pass or notch filters for example).

During this design phase it is also possible to make a first tuning of the control parameters and when the system will be completely assembled, it will be possible to start the tests and final tuning with these estimated values.

This section describes the strategies that will be implemented to develop the control design and performance analysis of the raster scan, and which are typically used by EIE to design the motion systems of high performance telescopes.

The process follows these steps:

- o FEM analysis (see previous paragraph)
- o State space representation of the FEM model.
- o The modal representation of the structure is obtained from the FEM, by extracting those eigenmodes, which are more significant for the modelling of the dynamical behaviour of the structure. For telescope technology, this step is typically accomplished using the Matlab function "balred" that minimize the H₂ norm of the transfer function between all the inputs and all the outputs. Usually a cross check with other reduction techniques ("modered") is performed to assess the best strategy for model reduction. The following figure shows an example of this part of the activity, carried out for telescopes.

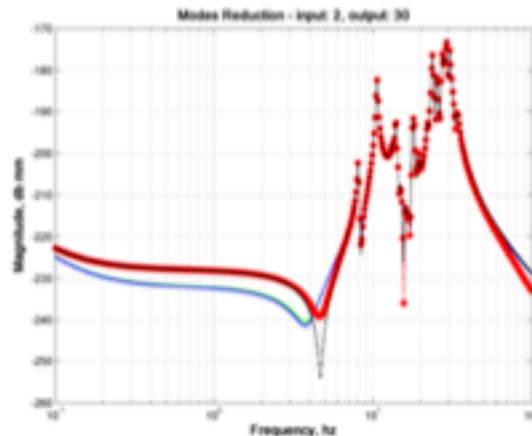
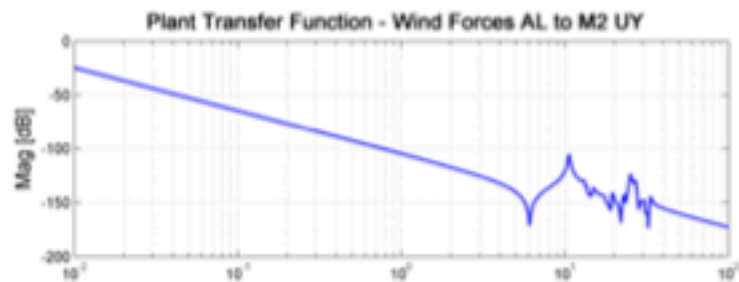
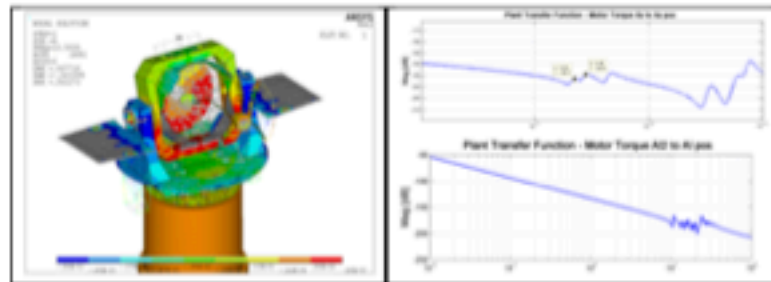
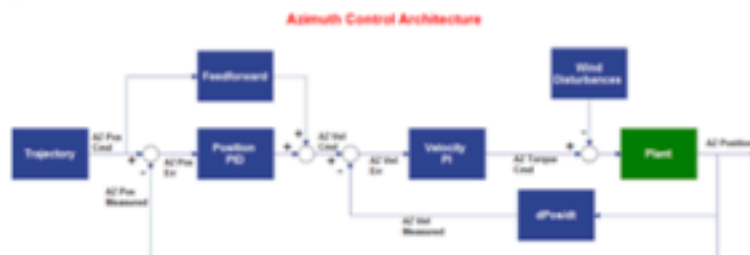

Figure 1-23: Damping versus Frequency of the oscillations.

- o Plant Transfer Function
The main objective of this analysis is to study interaction between servos and structural dynamics. In particular, for the control development is important to estimate the first resonant frequencies.
As a control design guideline, it is common to consider the very first resonant frequency as the maximum allowed bandwidth of the position closed loop transfer function to avoid the excitations of the structural vibrations and preserve the system expected lifetime. Cross coupling effects are typically investigated. System perturbations are always modelled and taken into account. For telescope technologies, one of the main disturbances depends on the wind force acting on the structure. For XRS case, potential disturbances could depend on vibrations induced by the vacuum pumping system. EIE has considerable experience in the development of vibration analysis (E-ELT). The following pictures show some examples of this part of the analysis, typically made for telescope applications.



- Control design
 The controller design usually considers a linear model of the system, including the structural modes resulting from the state space representation to evaluate the stability of the position closed loop.
 The controller design is initially performed in the continuous time domain. The velocity controllers are developed before the of the position controllers for the axes, with the main objective of guaranteeing the robustness and performances. Then the position controllers are developed considering mainly the robustness, the closed loop transfer function bandwidth to avoid the excitation of the structural modes, and the tracking requirements. The analysis includes the modelling of friction effects (Stribeck effect, stick-slip, viscous friction).
 The following picture shows a typical implementation of the control loop for telescope applications.



- o Continuous modelling
The previous models and simulations are used to perform a continuous modelling of the system to assess the performances of the velocity control loops and position control loops. The model used in the simulations typically includes the ripple and cogging torque disturbance, Stribeck friction, contribution to viscous friction for the relevant axis and the external disturbances. The following pictures shows some typical results of the analysis.

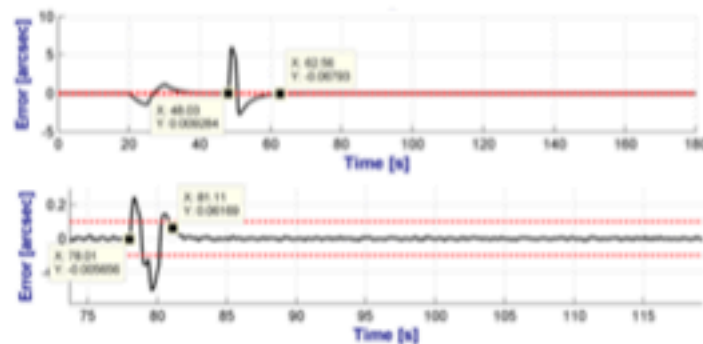

- o Discrete system modelling
The complete model is analysed introducing all the significant aspects related to 'real world' implementation and the tracking simulations are performed to validate the control design. The discrete model is obtained considering the following aspects:
 - Encoder quantization
 - servo loop sampling
 - loop latencies
 - trajectory rate limits
 - friction effects

The servo loop sampling and the loop latencies can be represented as digital buffers with a delay length of two sample period.

All the continuous transfer functions are discretized, usually using the bilinear transform (Tustin's method). This transform is usually chosen because it guarantees the stability of the digital controller.

It's important to be noted that the digital controller sampling frequency has to be chosen appropriately taking into account the control bandwidth (correlated to the discretization frequency warping effect) and the plant dynamic behaviour to avoid aliasing on measured signals. Typical results are shown in the following pictures.

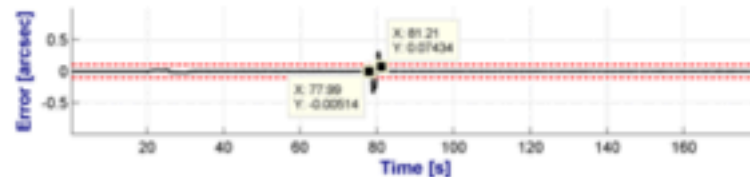

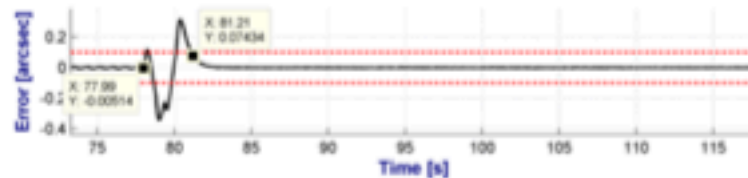

- o Tuning
 Refining of the control loop parameters is usually performed to achieve best performances and to assess the system sensitivity.

1.3.5.5 Error budget

Table 1-5 and Table 1-6 provide the error budget for the X-ray beam attitude. In particular, Table 1-5 reports the main error sources and their preliminary evaluation, while Table 1-6 reports the final errors calculated by composition of the various sources.

Three scenarios have been considered, labelled case A, B, and C:

- Case A has only tiltmeters (no optical metrology) placed on the Gimbal inner ring. Since the tiltmeters are on the Gimbal, the Serurier truss deflection is summed as separate item.
- Case B has only tiltmeters (no optical metrology) placed next to the Collimator and the Source. The deflection of the Serurier truss is read by the tiltmeters, thus it is included in the tiltmeters accuracy and it is not summed as separate item.
- Case C has optical metrology on the Gimbal ring. As per case A, the deflection of the Serurier truss is summed as separate item.

The scenario with optical metrology placed next to the Collimator and the Source has not been taken into account because it is difficult to set up (sec. 1.1.3.2.4).

Table 1-5: Error budget on the X-ray beam attitude (RMS error sources).

Description	X rotation error RMS [arcsec]	Y rotation error RMS [arcsec]	Notes
Serurier deflection, gravity	0.07	0.05	From FEM.
Serurier deflection, linear guides shape error	Likely to be small w.r.t. gravity error.		See sec. 1.1.3.2.7.3 on deformation due to linear guides shape errors.
Tiltmeters	0.2	0.2	Tiltmeter Jewell 755-high-gain.
Optical metrology	0.1	0.1	See sec. 1.1.3.2.4 on the tip/tilt metrology.
Servo error	<0.1	<0.1	See sec. 1.1.3.2.5 on the control system.

Table 1-6: Error budget on the X-ray beam attitude (final errors).

Description	Total error RMS [arcsec]	Notes
Total error, case A	0.33	Tiltmeters on Gimbal, no optical metrology.
Total error, case B	0.32	Tiltmeters on Collimator and Source, no optical metrology.

Total error, case C	0.22	Optical metrology on Gimbal, tiltmeters in support.
---------------------	------	---

Error sources have been composed through a SRSS, which is a valid method only for RMS values of uncorrelated sources. In first approximation this hypothesis is acceptable, and it leads to RMS errors starting from input data considered as RMS values.

The baseline for this tender is with the optic metrology on the Gimbal inner ring and the tiltmeters in support (case C, see sec. 1.1.3.2.4), thus the expected error for the beam attitude is 0.22 arcsec RMS, to be compared to the specification limit of 1 arcsec (R31).

1.4 The question of the MA support and gravity distortions

Since integration and testing will be carried under tight thermal control, the gravity represents the main source of the Mirror Assembly (MA) structural distortions. Mass and vignetting limits, coupled with the very strict stiffness requirements arising from challenging optical requirements and from the large size, do not allow the design of a MA structure whose stiffness is intrinsically sufficient, when simply supported in kinematic mount condition or supported just at the outer edge.

Furthermore functional requirements resulting from the optical design poses additional constraints to MA structure design. If one e.g. refers to the Mirror Module (MM) pattern, the configuration does not permit to realize continuous radial walls (except in six azimuthal locations 60° spaced). Discontinuous radial walls result in poor stiffness performances. Moreover, the high MM packing density leaves just a small room to include structural stiffening elements. All the aspects mentioned above results for ATHENA in a monolithic MA structure consisting in a sort of spatial frame in the azimuthal plane, composed by thin walls surrounding fully open cells, which constitute the MM housings. See the structure concept in Figure 1-24. The use of all pattern and thickness are mainly ruled out by the optical design (in order to avoid vignetting), while more freedom is available concerning the depth in axial direction.

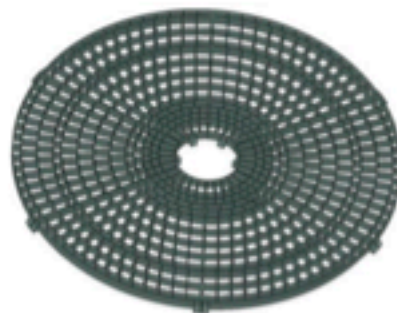

Figure 1-24. Concept of MA structure. The picture refer to an overtaken MA sizing.

Hence for VERT-X there is the need of designing a dedicated and optimized supporting system, in order to mitigate the gravity distortions. In the vertical facility we are proposing the MA is subject to gravity in axial direction. It should be noted that such a configuration has some advantages with respect to lateral gravity imposed by other calibration facilities based on the classical horizontal configuration (with gravity perpendicular to the optical axis). In particular, the following aspects should be specifically considered:

- The MA structure seems stiffer in the case of axial (rather than lateral) gravity. Such a statement has been proved in past activities carried out for simulating petal MA structures in the context of the ESA program ASPHEA (the simulation was carried out with the MA structure divided in six independent sectors, each of them was 60° wide). The HEW under lateral gravity of the single petal with kinematic supports in points at outer and inner radius, was a factor 10 worst with respect

to the case with axial gravity. For the current monolithic MA design we have not yet any assessment available, but we think that axial gravity remain less harmful. A proof of such statement, by numerical modeling, is envisaged, once MA design and the relevant Finite Element Model will be made available during the development of the activities.

- Compliance between the raster scan facility and the UV vertical integration facility that will be used for the assembly of the MA. In both facilities the MA is subject to axial gravity. The support system in scan facilities shall basically duplicate that one already used during the MM integration into the MA. That makes easier the design of the MA structure, which must be compliant just with one gravity mitigation support system.
- The gravity mitigation support system seems less complex for axial gravity. Indeed, it is not necessary to compensate distortions coming from overturning moments related to lateral gravity and the implementation of supports at intermediate radial coordinates appears much simpler.

The raster scan facility can be used also for intermediate verifications to be carried out during the MA integration, i.e. operating with partially populated MA. As already stated in the previous studies, it seems appropriate to make the integration under constant mass, by using dummy MMs equivalent to real MM for mass. At the beginning of the MM integration, the MA structure is loaded by the full MM mass (using dummies). Before a new MM is integrated, the correspondent dummy mass is removed. In that way the integration becomes a sort of "mass steady" state process and, as a consequence, no cumulated deformation are stored due to increased mass.

However the MM integration could also have an impact in terms of stiffness, since its connection to the MA is a "quasi" kinematic mount but it is not a "perfect" kinematic mount. In that way each integrated MM could add a small stiffness contribution to the MA in other terms the global MA stiffness, under axial loads, could increase during the integration process. In principle, this effect could have an impact on the distortions of the MA supported by the gravity mitigation supports. During the activities such phenomenon will be assessed, to understand if it is negligible in terms of impact on PSF or if it has to be accounted for in the design of the gravity mitigation support system. In any case, a proper supporting system with possible use of actuators will be designed.

1.5 The X-ray system

The X-ray system is formed by:

- an X-ray source, with micrometric target and high flux is placed onto a movable X-Y translation stage at a distance of 2-4 m from the collimator grazing incidence mirror, in the lower part of the facility. The X-ray source produces a polychromatic isotropic beam via "bremsstrahlung" in the 0.1 – 15 keV range, with the characteristics fluorescence lines superimposed. The source has the possibility to play with different targets, filters and bias voltages in order to tailor the emission spectra depending on the needs for the calibrations;
- a good quality X-ray collimator optics which is used to parallelize and widen the X-ray beam. It is based on a parabolic grazing incidence mirror fabricated using a thick substrate (a few cm) in Silicon or glass-ceramic (similar to the grazing incidence systems used to condition the X-ray beams in synchrotron light beam-lines) with a focus placed at an average distance of 1.5 - 5 m, able to produce at the exit of the pupil a few cm² large polychromatic flux with low divergence (<1 arcsec HEW). The focus of the X-ray optics corresponds to the position of the X-ray generator target. It should be noted that EUV/X-ray optics to widen and collimate the beam for the calibration of X-ray telescopes have been already studied and will be also used in the context of the BEATRIX facility

The X-ray system, formed by the collimator mirror mounted onto a truss at the focal distance from the X-ray source. The system is used for making the X-ray raster scan measurements.

1.5.1 The X-Ray source

The baseline X-ray source is a microfocus sealed tube with a diverging beam. Possible providers are Incoatec (incoatec.de) in Germany and Sigray (sigray.com) in USA. The Incoatec μ S source is shown in Figure 1-25. X-ray source and performance.

Available anodes allow also Cu-K_α, Ti- K_α, Mo- K_α and Ag- K_α fluorescence lines superimposed to the continuum. The source withstands at least 10,000 h of operation time and dissipate a power lower than 30 W. The Incoatec Source can work in a high vacuum environment and it is characterized by a) no moving parts, b) long lifetime without maintenance; c) no water cooling; d) short warm-up time; e) a very high stability. Incoatec μ S source is powered by a small generator unit which easily fits into a 19 inch rack. The complete system is radiation safe and vacuum tested. The focus spot size of 100 μ m FWHM (see Fig.1-25) can be reduced with a pin-hole, in fixed position, connected to the vacuum tube via a flange. It should be noted that the pin-hole will be placed very closed to the emitting surface because otherwise the beam divergence (5-7.5 mrad) is further limited by the pin hole. Assuming an average distance from the source to the optics of e.g. 0.5 m (see next section), in order to achieve a collimation of 1 arcsec = 5 μ rad, the pin-hole should have a radius of 2.5 μ m maximum. Since the peak flux density of the source is about 30×10^9 photons/s/mm² (see Figure 1-25), the total number of emitted photons out of the pin hole is about 600,000 photons/s. Assuming the emission is in a cone of 7.5 mrad (see Figure 1-25) or about 4.4×10^{-3} sr, then the intensity of the source is of the order of 1.33×10^{13} photons/sr/s.

The Sigray FFAST-Micr (Fig. 1-26) has a declared spot size of only 8 μ m and potentially may have an even higher intensity. Deeper analysis of this source will be performed during the project. It should be noted that the source is apparently (from Figure 1-26. Pictorial image of the Sigray FFAST-Micro™ X-ray source.

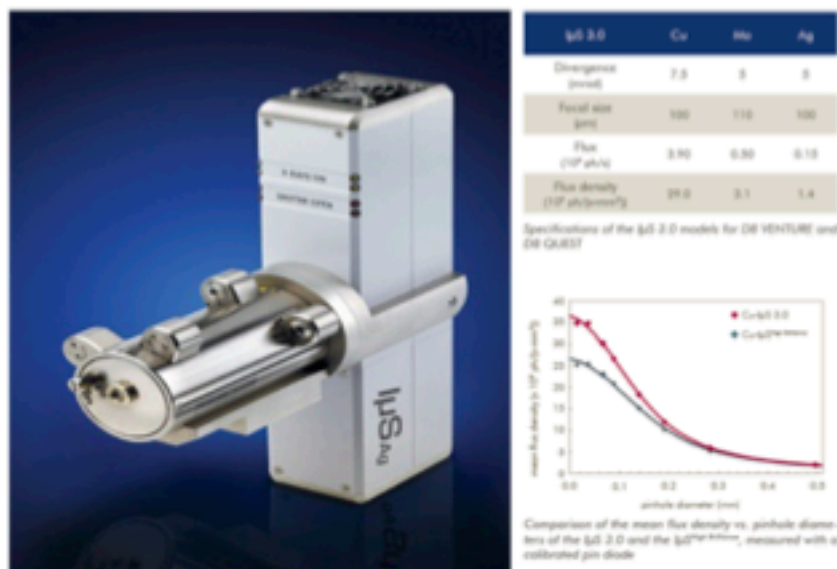

Figure 1-25. X-ray source and performance.

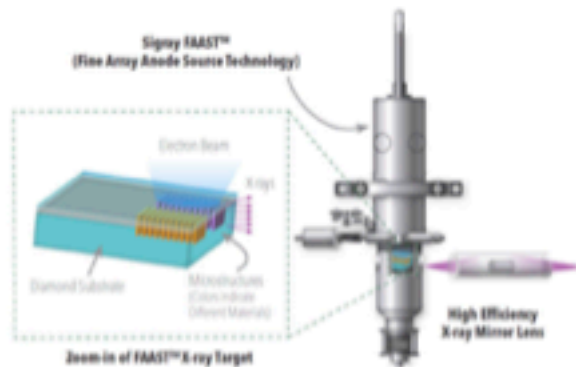

Figure 1-26. Pictorial image of the Sigray FAAST-Micro™ X-ray source.

1.5.1.1 The X-ray Collimator

1.5.1.1.1 Design of the parabolic collimator

We assume that the X-ray source (XRS) consists of a small source that can be approximated by a point-source and a collimator obtained by placing the source at the focus of a parabolic mirror. At X-ray energy grazing incidence is required to get a non-vanishing reflectivity. For reference, the theoretical grazing incidence reflectivity of 1 keV photons on a Gold-coated mirror of 1 nm rms roughness is shown in Figure 1-27. Theoretical reflectivity of 1 keV X-rays on a Gold-coated mirror (source Center for X-ray Optics, www.cxro.lbl.gov)

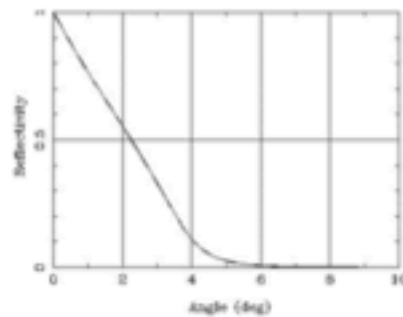

Figure 1-27. Theoretical reflectivity of 1 keV X-rays on a Gold-coated mirror (source Center for X-ray Optics, www.cxro.lbl.gov)

Given a parabolic surface of equation $z = r^2/4f$, where z is the axial coordinate and r the distance from the optical axis, the grazing incidence angle of a light ray propagating from the focus at a given point (r, z) of the

parabola surface is $\alpha \cong \tan \alpha = dr/dz$. By derivation of the parabola equation, we get $r = 2f/a$. Finally, inserting this back into the parabola equation we obtain $z = f/a^2$. Since the focus is at distance f from the vertex, the axial distance between the source and the incident point on the parabola for a given grazing incidence angle α is given by

$$d = \frac{f}{a^2} - f = f \frac{1 - a^2}{a^2}$$

and is proportional to the focal length. Figure 1-28 shows the dependence of z on f for three values of $\alpha = 0.5^\circ$, 1° and 2° . Clearly, for the practical implementation of the mirror, the focal length must be smaller than few millimeters.

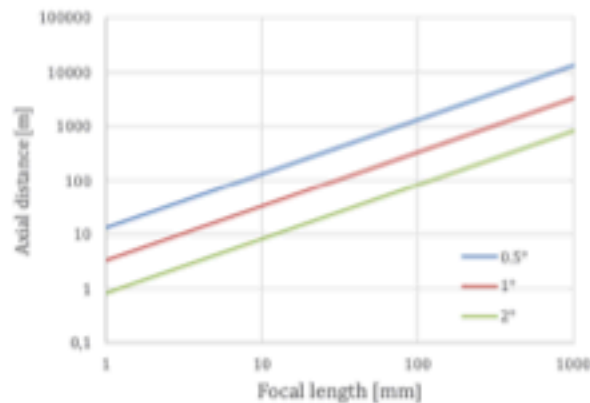

Figure 1-28. Axial distance between source and reflection point as a function of the focal length, for three values of the grazing incidence angle, 0.5° , 1° , 2° .

If we require that the grazing incidence angle on the parabolic surface ranges between α_1 and α_2 , then the mirror is the section of parabola between the axial coordinates $x_2 = f/\alpha_2^2$ and $x_1 = f/\alpha_1^2$; the corresponding radial coordinates are $r_2 = 2f/\alpha_2$ and $r_1 = 2f/\alpha_1$. The length of the optics is

$$L = x_1 - x_2 = f \frac{\alpha_1^2 - \alpha_2^2}{\alpha_1^2 \alpha_2^2}$$

If the mirror is azimuthally limited between $-\varphi$ and φ , then the cross section of the beam is an arc of annulus between radii r_2 and r_1 and between $-\varphi$ and φ . The radial dimension of the annulus is

$$D = r_1 - r_2 = 2f \frac{\alpha_2 - \alpha_1}{\alpha_2 \alpha_1}$$

and the area of the beam cross section is

$$A = \varphi(r_1^2 - r_2^2) = 4\varphi f(x_1 - x_2) = 4\varphi L f$$

For example, if $\alpha_1 = 0.5^\circ = 8.7 \text{ mrad}$ and $\alpha_2 = 1^\circ = 17.5 \text{ mrad}$, then $L = 9848.4 \cdot f$ and $D = 114.6 \cdot f$. The focal length is determined by practical limitation of L and, possibly, by the desired value of D . If, for example, $L = 0.5 \text{ m}$, then $f = 0.051 \text{ mm}$ and $D = 5.8 \text{ mm}$.

The azimuthal extension of the annulus is limited by the maximum acceptable sag of the optics, which is given by $\Delta = r(1 - \cos \varphi)$. The relative sag $\Delta/r = 1 - \cos \varphi$ independent from position along the mirror. The width of the mirror is then $W = 2r \sin \varphi$. If $\Delta/r = 0.1$ in the above example, then $\varphi = 26^\circ$ and $W_{\text{max}} = 10.2 \text{ mm}$.

1.5.1.1.2 Intensity distribution of the collimated beam

Assuming isotropic emission from a point source in the focus of the parabola, the beam is uniform along the azimuth direction of the annulus arc. Along the radial direction, instead, the intensity is modulated by the reflectivity of the coating and by the geometry of the mirror.

If I_0 is the incident intensity on the mirror (number of photons per unit solid angle and per second) and if $R(\alpha)$ is the reflectivity for a given energy at the grazing incidence angle α , the number of reflected photons per second at a given mirror position is (for small angles)

$$I_0 R(\alpha) \sin \theta d\theta d\varphi \cong 4 I_0 R(\alpha) r d\alpha d\varphi,$$

where $\theta = 2\alpha$ is the emission angle with respect to the axis of the parabola (z-axis). Since $r = 2f/\alpha$, this can be written

$$\frac{16f^2}{r^3} I_0 R \left(\frac{2f}{r} \right) dr d\varphi.$$

By converting to local orthogonal coordinates by setting $d\ell = r d\varphi$, the intensity of the collimated beam (number of photons per unit area and per second) is

$$I(r, \ell) = \frac{16f^2}{r^3} I_0 R \left(\frac{2f}{r} \right).$$

A strong dependence on the radial position r can be noted. Even ignoring the dependence on the reflectivity, in the previous example the intensity varies by a factor 16, since α , and so r , changes by a factor 2. Moreover, for a given value of the grazing incidence angle, $\alpha = 2f/r$, the intensity is proportional to r^{-2} . Thus, it is useful to keep r small (and so f) to increase the beam intensity.

Fig. 1-27 shows the dependence of the transmission $I(r, \ell)/I_0$ on the radial coordinate of the collimated beam for the example discussed above and assuming 1 keV photons reflected by Gold coating. Assuming the source configuration described in the previous section, the intensity on the mirror is about $I_0 = 1.33 \cdot 10^{20}$ photons/sr-s. The intensity of the beam on the ATHENA optics is then obtained multiplying the curve of Fig 1-27 by I_0 . The result is shown in the same Figure 1-29. Dependence of the intensity of the collimated beam from the radial coordinate at 1 keV for the example discussed in the text.

One can optimize the system by opportunely choosing a parabolic collimator with reflecting angles sufficiently small in order to get an X-ray flux with a good spectral homogeneity after the reflection, as e.g. the following example:

- Distance from the source: 2 m
- $f=0.15$
- Mirror Length: 650 mm
- Footprint height: 5.22 mm
- Footprint radius : 39.87 – 34.65 mm

- Flux: 1.8234112×10^{-8} (Area sphere $r=2m/geo_ares$) as represented in the following figure.

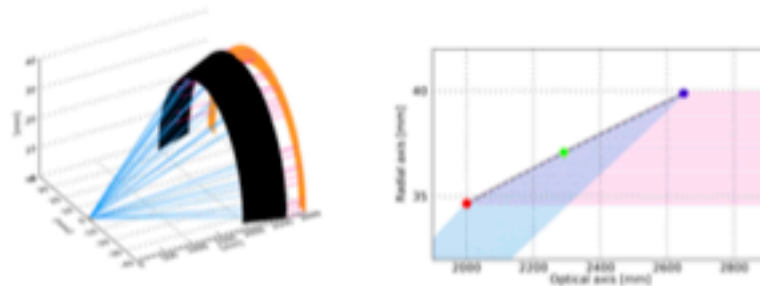

Figure 1-30. Geometry of the flux corresponding to the example of collimator described in the text.

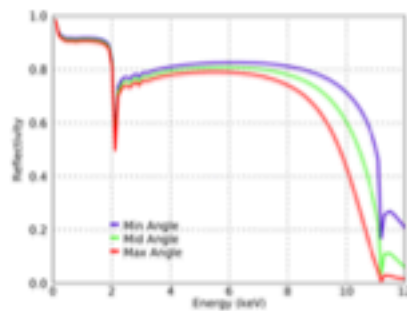

Figure 1-31. Geometry of the flux corresponding to the example of collimator described in the text.

The corresponding reflectivity as a function of the X-ray energy at the minimum, maximum and average reflection angles is reported on the figure here above. As can be seen, the difference in reflectivity is very small. A further cleaning, in particular for energies beyond 8 keV, can be obtained with an opportune filtering of the beam.

On the other hand, one should take into account the fact that the strategy that will be used for pursuing the calibrations using polychromatic beam foresees:

- measuring different portions of the Effective Area vs. Energy profiles in separate runs with different input spectra
- the X-ray spectrum for each run will be properly set taking into consideration target, applied bias, reflecting angles of the collimating mirror and filters in order to achieve the requirement.

Since X-ray cameras with a high energy resolution and high angular resolution will be used for VERT-X, then the detection system would itself be able to disentangle and normalize in the proper way possible differences in the homogeneity of the beam, provided that the flat field is well characterized with flat field calibrations.

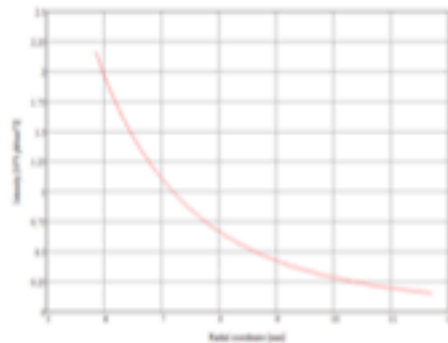

Figure 1-29. Dependence of the intensity of the collimated beam from the radial coordinate at 1 keV for the example discussed in the text.

One can optimize the system by opportunely choosing a parabolic collimator with reflecting angles sufficiently small in order to get an X-ray flux with a good spectral homogeneity after the reflection, as e.g. the following example:

- Distance from the source: 2 m
- $f=0.15$
- Mirror Length: 650 mm
- Footprint height: 5.22 mm
- Footprint radius : 39.87 – 34.65 mm
- Flux: $1.8234112e-08$ (Area sphere $r=2m$ /geo_area)

as represented in the following figure.

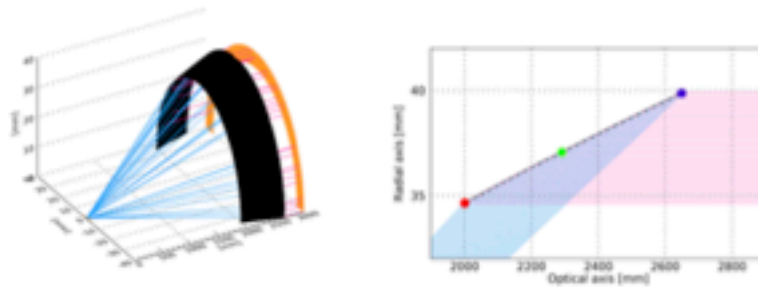

Figure 1-30. Geometry of the flux corresponding to the example of collimator described in the text.

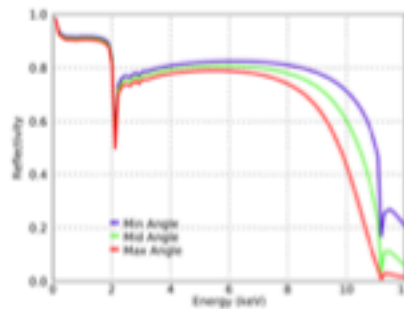

Figure 1-31. Geometry of the flux corresponding to the example of collimator described in the text. The corresponding reflectivity as a function of the X-ray energy at the minimum, maximum and average reflection angles is reported on the figure here above. As can be seen, the difference in reflectivity is very small. A further cleaning, in particular for energies beyond 8 keV, can be obtained with an opportune filtering of the beam.

On the other hand, one should take into account the fact that the strategy that will be used for pursuing the calibrations using polychromatic beam foresees:

- measuring different portions of the Effective Area vs. Energy profiles in separate runs with different input spectra
- the X-ray spectrum for each run will be properly set taking into consideration target, applied bias, reflecting angles of the collimating mirror and filters in order to achieve the requirement.

Since X-ray cameras with a high energy resolution and high angular resolution will be used for VERT-X, then the detection system would itself be able to disentangle and normalize in the proper way possible differences in the homogeneity of the beam, provided that the flat field is well characterized with flat field calibrations.

1.5.1.1.3 Manufacturing and tolerance of the collimator

Different materials can be considered for the manufacturing of the X ray mirror collimator. As material reference for trade-off during the project development, we considered "glass" (i.e. fused silica, Zerodur®, etc.) and NIP-coated Aluminum mirror. The latter choice has the disadvantage of the high coefficient of thermal expansion (CTE) and bimetallic effect. However, in the application considered in the framework of this project, the thermal environment is quite stable and the possibility of using metallic mirror should be taken into considerations. Another possible material to be considered is Silicon, which has a CTE small and a high thermal conductivity.

An example of parabolic collimator is shown in Figure 1-32. X Ray Collimator Mirror



Figure 1-32. X Ray Collimator Mirror

Given the application under consideration in a controlled environment, the mechanical and structural design and the manufacturing of the mirror do not rise serious concerns except for the required shape accuracy and roughness.

The target specification for the collimation of the X-ray beam at the exit of the mirror is set to 1 arcsec HEW or about 5 μ rad. The three main contributions to the accuracy of the beam collimation are the finite dimension of the source, the relative alignment between source and the mirror and the figure error of the mirrors. Assuming such contributions add in quadrature, by equally splitting the available budget among the three terms, the shape error should contribute to the beam collimation with less than 2.9 μ rad or about 1.5 μ rad on the mirror surface.

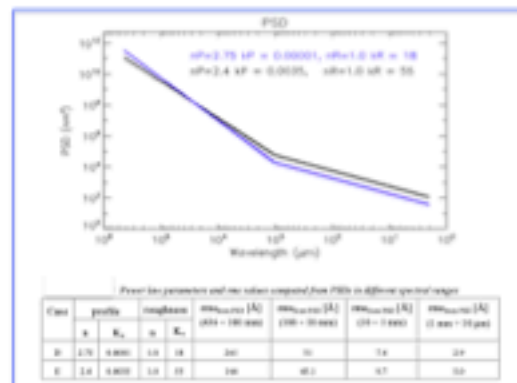

Figure 1-33. Tolerances in terms of Power Spectral Densities (two broken power laws).

The fabrication tolerances are similar to the parabolic mirror being realized to collimated the X-ray beam at 1 arcsec HEW in the BEATRIX facility, reported in the figure hereafter. Two different broken power laws for Power Spectral Density of the surface errors are considered, all returning an expected HEW < 1 arcsec (see Figure here above). The mirror is doable because these tolerances are similar to the ones assumed also for large grazing incidence mirrors for X-ray synchrotron radiation applications. There are several manufacturers able to make the polishing and figuring of the mirror, including Media Lario and INAF/OAB that have the necessary metrological and polishing equipments (in particular the Zeeko bonnet polishing

machine and the ion figuring facilities for the final correction).

1.6 The X-ray service camera

The service camera should be able to sample the PSF with a proper spatial accuracy, large area (in order to make flat fields onto a large and representative detection section), a sufficient energy resolution and able to operate in photon counting mode. Due to the required range of sensitivity, large format, spatial resolution, and energy resolution, commercial solutions based on soft x-ray CCDs with photon counting capabilities have been investigated. In particular, a critical tradeoff need to be evaluated between the readout noise (affecting the energy resolution and the low energy threshold in photon counting mode) and the frame rate (which is strictly related to the maximum sustainable flux).

A possible baseline has been identified in the Fast CCD X-ray Detector produced by Sydor. The camera is based on a custom, LBNL developed, back-side illuminated CCD manufactured using the Teledyne/Dalsa 150mm C25 2.5 μ m process. The sensor area is a 960 x 1920 array of 30 μ m pixels and can be used as a 960 x 960 pixels split frame store device (under request, a mechanical light block is included on top of the sensor to isolate the sensor imaging area from the frame store area), i.e. with the sensitive area at the center of the device and two frame store sections at the top and at the bottom.

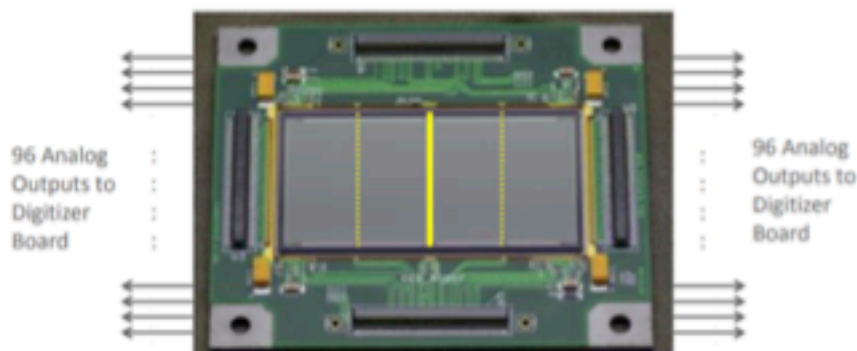

Figure 1-34. Sydor CCD picture.

To provide maximum sensitivity for Soft X-Rays, the sensor is thinned to 200 μ m and then ion-implanted on the back side with a 10 nm entrance window to provide transmission efficiencies of greater than 75% from 200eV, 95% at 600eV, and approaching 99% at 1keV. The readout architecture is highly parallel, with 96 outputs on each of both sides (one every 10 columns, with each column splitted on two outputs). The front-end electronics is based on custom ASICs developed at LBNL, allowing a very high frame rate with moderate readout noise (< 30 e- at 120 frames/s full frame). This translates into:

- pileup < 10% for flux up to 12 counts/(pixel*s)
- threshold for photon counting ~0.5 KeV
- energy resolution FWHM~250 eV

The Sydor camera main blocks are:

- a vacuum-compatible (<10⁻⁷ torr) camera head which includes, in addition to the sensor, the front-end electronics, the mechanical mounting with a temperature stabilization subassembly
- a cooling subsystem consisting of an Immersion Probe Cooler system and a closed loop temperature controller system, to maintain the sensor at the optimal working temperature (~-50°C), with stability within 1°C
- a data acquisition readout system based on a ZNYX 1900 ATCA System Crate and 10GbE/1GbE Hub Blade

In order to assess the preliminary design of the (x, y, z) Stage (XYZS), the requirements R38-R43 were analyzed and assessed.

The XYZS shall be able to move a mass of about 4 kg (TBC) on three perpendicular directions (x, y, z), inside a vacuum chamber at approximately 10^{-6} Torr (TCB).

The XYZS movement shall be guaranteed with the required precision, within the following values:

- Z direction: movement of at least ± 50 mm, with steps of 0.25 mm, accuracy ≤ 0.25 mm
- X and Y directions: considering the $\pm 3^\circ$ values (180 arcmin), at an height of 12 m (according to para 1.4.2), the movement shall be between 630 and 1260 mm (TBC), with an accuracy ≤ 0.03 mm

Considering the requirements and the available technical values, the movement of the XYZS will require precision made screws (manufactured ad-hoc or off-the-shelf will be assessed during the study, with a smooth sliding, also considering accuracy and moved mass. In this perspective, and considering the vacuum environment, assessments will be made during the study to understand if to utilize:

- Vacuum resistant lubricant, for the mechanical part movements, like the NyeTorr
- Low friction, self-lubricant mechanism with sintered plastic materials

After the previous assessments the study will perform a preliminary design of the XYZS. According to initial considerations, the XYZS will appear as a holding plate mounter or linear rails, on the X and Y directions, and this will be mounted on a structure allowing the Z movement.

The movement will be performed thanks to electrical motors and recirculating balls screws, or trapezoidal screws, both at low friction.

The need of thermal treatment and other material treatment will be considered during the preliminary design phase.

1.7 X-ray scanning strategy and performance

The core of the ATHENA MA calibration campaign, will be the measures of the PSF and of the EA according the requirements stated in [RD2]. The facility will operate translating in X and Y the X-ray source system of the X-ray source and mirror for collimation in order to scan the Athena optics. The flat field will be taken at the center of the ATHENA Mirror Assembly, where there is a hole that allows to register on the detection camera the X-ray beam without being reflected by the mirror shells of the telescope. The cameras will operate in photon counting mode, allowing to couple via time-stamp the detection time to the position of the X-ray source. Proper metrological and feedback systems will be installed on the tower hosting the X-ray source and parabolic mirror.

In our proposed approach we will have a ~ 30 keV bremsstrahlung continuum incident flux, producing a count rate of 50 c/s, in the 0.2 - 12.0 keV range. It should be noted that one can operate also using the fluorescence lines emerging from the continuum (depending on the target) opportunely filtered. We note that the rate of 50 c/s is conservatively a factor of two less than the pile-up limit allowed by the X-ray service camera. In fact, the detector proposed in Section 1.1.3.5, with a pixel size of 0.5", a frame time of 0.01 s and it can read 100 c/s of a 5" HEW PSF with negligible ($<1\%$) pile-up. The bremsstrahlung source is in the focus of a collimator which produces a parallel beam of a 5 mm size. Source and collimator are mounted on a raster scan system with a (conservative) velocity of 5 mm/s, which allows us to perform a complete scan of the ATHENA optics in ~ 2 days. Off-axis beam can be obtained by tilting the system up to 3 degrees, and, when necessary, correspondingly moving the detector stage.

The core of the proposed calibration strategy will consist in N 2-days observations in different positions of the FOV, which will provide all the data necessary to accomplish the calibration task as requested. No significant overhead is foreseen among the N observations.

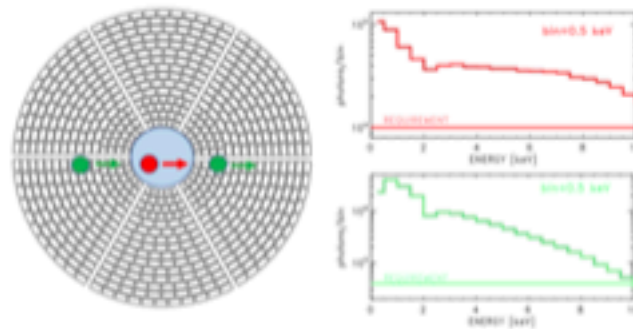

Figure 1-35. (Left) Concept Raster scan measurement, with the flat-field calibration in the empty circle at the centre of ATHENA's MA. (Right) Polychromatic spectra considered for simulation.
 Requirements on PSF calibration are given for core, extended core and wings at seven different energies all over the FOV. In order to estimate the counts necessary for the fully compliance, we simulated a PSF with HEW of 5" and a slope of the wings, resembling the one of XMM. As shown in Fig. 1-33, the output of the simulations indicate a need of ~40,000 for each energy for each position in the FOV.

For each required energy we will measure the PSF exploiting the spectral resolution of the detector. We simulated a bremsstrahlung source with an energy dependent PSF and observed with a detector with 300 eV spectral resolution. As shown in Figure 1-33 we found that we can accurately reconstruct the energy dependence of the HEW.

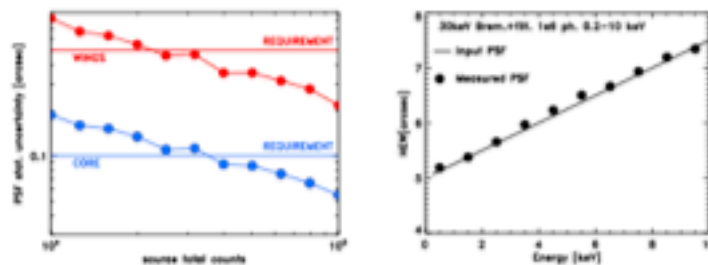

Figure 1-36. (Left) PSF statistical uncertainty versus total counts. (Right) HEW versus photon energy.

During a 2-day observations the moving source will scan the MA for ~95%, while in the remaining 5%, the emitted photons will directly reach the detector through the circular aperture (60 cm diameter) at the center of the MA. The MA effective area measure will be given by the ratio of the spectrum registered in the time intervals when the source is scanning the optics, with the spectrum registered in the intervals when the source is over the circular aperture (usually called "flat-field"). We note that the statistics of this latter spectrum (the flat-field) will be the main factor in the uncertainty of the EA measure. To meet the requirements in the EA calibration accuracy, we should ensure at least 10,000 counts in each energy bin considered in the flat field spectrum.

Since most of the bremsstrahlung photons will be soft (<10% of photons > 5 keV, with kT=30 keV) and since the reflectivity of the collimator and of the MA will further-on soften the spectrum, different strategies can be adopted in order to minimize the exposure times.

As shown in Fig 1-32 assuming a 30 keV max energy bremsstrahlung spectrum with an high-pass filter (0.1 mm Beryllium equivalent), assuming a 2-day observation with a 50 c/s rate would we would nearly meet the requirements of 40,000 and 10,000 photons for each 0.5keV bins for the MA reflected beam and flat field respectively.

1.8 The building hosting the X-ray Scanning Facility

The configuration of the facility strongly depends on the process defined to manage the integration of the Raster Scan, the Mirror Assembly and the Science Instrument Module inside the vacuum vessel, from the incoming area where each package arrives, to the ISO-5 rooms.

The process defines the size and location of the clean rooms, the space that is necessary for the personnel, and the technologies and technical solutions that must be put in place to guarantee the required cleanliness condition for any manipulation of ATHENA sub-systems.

Once the configuration of the clean rooms is defined, the facility conceptual layout shall take into consideration safety regulations, and it shall allocate the volumes that are necessary for the following functions / systems:

- technical rooms of the vessel (including control room, RD46);
- technical rooms of the building;
- offices and rooms for the personnel dedicated to the management of the facility (RD46);
- meeting room (RD46);

According to R47 and R48, the facility shall be designed as a stand-alone outdoor building, and it shall be independent on specific location / site. In our understanding, the compliance to this requirement shall be intended apart from any possible compliance with local regulations in terms of earthquakes protection, which might change from site to site, and apart from any possible consideration on soil composition, which might lead to different solutions for what concerns the foundations design. As a general rule, the vessel will be installed over a different foundation w.r.t. the rest of the building.

We remark that the following configuration is based on an "upside-down raster scan"; reversing the Xray beam has strong consequences on:

- The vacuum vessel structure, which has now the bigger part on the top.
- The raster scan, MA, and SIM assembling, aligning, and maintenance procedures.
- The vacuum vessel doors and the cleanroom general layout to grant access to the various levels with the proper handling tools.



Figure 1-37. XRS hosting facility.

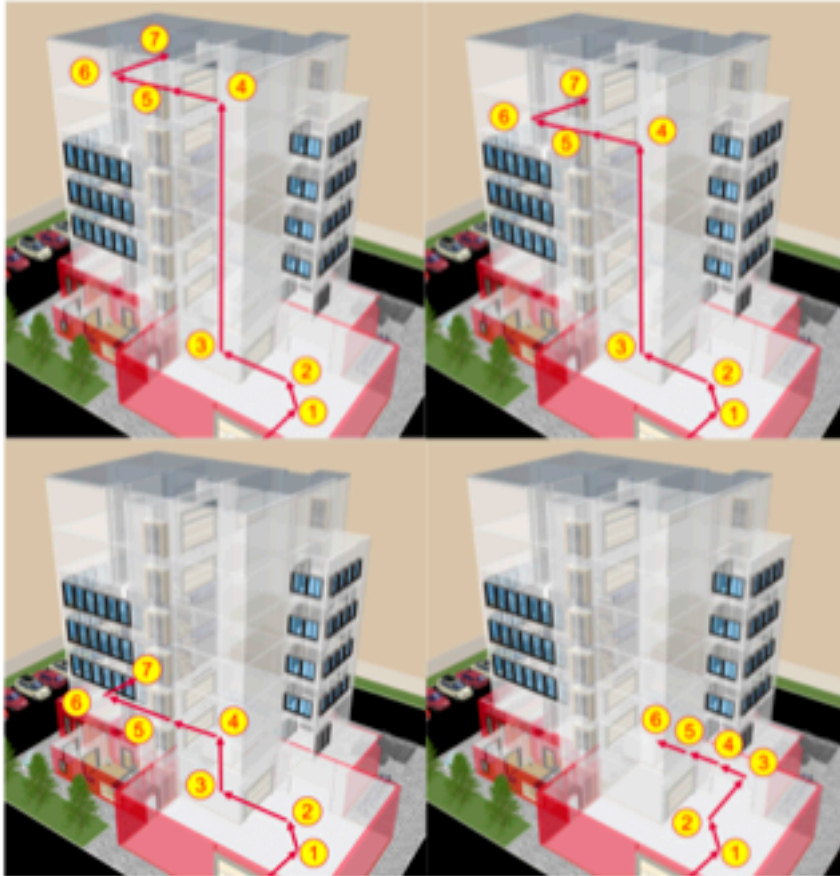

Figure 1-38. Path inside the building for the integration of the systems inside the vessel, from the incoming area to the ISO-5 rooms.

A first iteration lead to the configuration outlined in Figure 1-37, XRS hosting facility.

. This conceptual layout is based on the schematic incoming process outlined in Figure 1-38. Path inside the building for the integration of the systems inside the vessel, from the incoming area to the ISO-5 rooms.

1. Arrival at the incoming area
2. Removal of the external package

3. Insertion into the good lifter (not for the Raster Scan, which enters directly from the ground)
4. Arrival at the respective floor (already in ISO8 for the Raster Scan path)
5. Arrival at ISO 8, cleaning and transit (ISO 6 for RS, intermediate protection removed)
6. Arrival at ISO 6, cleaning and transit, intermediate protection removed (ISO 5 for RS, internal protection removed, integration into the vacuum vessel)
7. Arrival at ISO 5, cleaning and transit, internal protection removed, integration into the vacuum vessel

The clean rooms configuration resulting from this process concept leaves a significant fraction of the building volume available for the technical rooms (see Figure 1-39. Building volume dedicated to the technical rooms.

The vacuum chamber will ensure an ISO5 environment in presence of the MA and SIM without their protective cover. Besides, the vacuum chamber will be served at each access point by an adequate cleanliness grade room.

The final lay-out of the clean rooms will be tailored according to the actual operations to be performed inside them. In particular, the compartmentalization of the spaces, the extension of the laminar flow areas – as well as the required laminar flow direction – and the definition of dedicated paths across the various rooms for both the instruments and the facility personnel will all be the result of a customization process in relation to the tasks to be performed.

Another assumption of the concept presented here is that the integration into the vessel is made from a floor placed at an elevation, w.r.t. the ground, close to the final position of the respective system. Alternatively, each system could be integrated into the vessel from the top part using an ISO-5 overhead crane: this approach reduces the amount of ISO-5 volume, which is necessary to perform the operations, but at the same time introduces some relevant safety issues related to the motion of the MA from the top of the vessel to the bottom.



Figure 1-39. Building volume dedicated to the technical rooms.

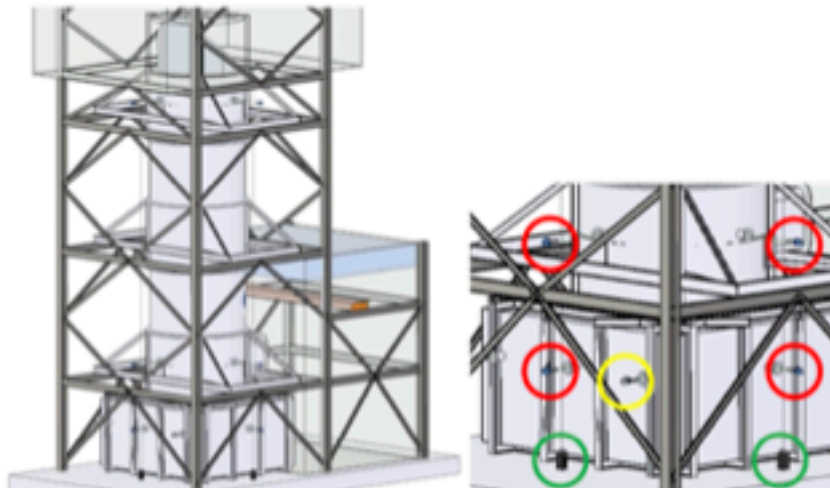

Figure 1-40. Metrology for the detection of the relative motion. The circles in red indicate the alignment telescopes that monitor the displacements of the Raster Scan, the Mirror Assembly and the SIM (this last on top, not shown on the right). The green circles indicate the API XD laser tracker, while the yellow circle indicate the autocollimator for the monitoring of the raster scan tip-tilt (connection of the basement not shown).

1.9 Overview of the metrology for the X-ray scanner

The linear absolute encoders of the raster scan give the position of the Serrurier and the X-ray collimator installed on board it. In our understanding the purpose of this optical metrology consists in ensuring that during the entire measurement the relative position of the three systems (raster scan, MA, SIM or detector) is continuously under control and any possible variation is adjusted by the actuators.

Being an internal, relative metrology, it is not strictly necessary to reference such measurements to a coordinate system placed outside the vacuum vessel. Even so, it is more practical to use an external metrology and viewports placed on the vacuum vessel. The first iteration on this part of the XRS facility led to the definition of the following configuration: a 3D laser measurement system from API Inc. is solidly attached to the basement of the vessel, on one side of it, pointing along the vertical. At each level of interest, i.e. raster scan, MA, and SIM, we place a unit, which is composed of the following main subsystems: a transmissive target, a shutter, an alignment telescope having the axis pointing towards a target attached to the respective assembly (raster scan, MA or SIM).

In this case, we cannot take advantage of the properties of the pentaprisms to fold the optical axis of the first alignment telescope, since what we want to measure are linear displacements. Taking into account for the sensitivity of the pentaprism, and making some reasonable assumptions on the distance between the pentaprism exit face and a target placed inside the vacuum chamber, we can easily find that the displacement measurement would be affected by an error of 0.03 mm for each arcsecond of rotation of the pentaprism. First, this is a significant part of the overall error budget, second it is likely that the pentaprism would be affected by a much larger rotation, being attached to the structure of the building.

We have to rely on a two steps measurement: the horizontal alignment telescope measures directly the displacement of the assembly under inspection, relative to its position. This can be accomplished with relatively high accuracy, of the order of few microns. At the same time we have to reference any motion of the three alignment telescopes to a stable reference. This is accomplished by the vertical laser system,

which measures the displacement of the each alignment telescope platform with respect to it (we assume that the platform of each alignment telescope is designed in such a way to behave like a rigid body: it might be realized in INVAR to minimize the effects of thermal dilatation).

This operation is more tricky, since in order to properly refer these last measurements to the former it is necessary to measure also the elongation (the optical axis of the alignment telescope is folded by 90 degrees w.r.t. the optical axis of the laser tracker). A possible solution to this problem consists in using a system like the API XD Laser measurement system, whose reference values are shown below. The shutter is used to distinguish between measurements made at different levels of the vessel tower. The beam is separated close to the emitter into three paths, one for each level to be monitored inside the vacuum vessel. The measurement acquisition process is such that once per cycle three measurements for each level are taken: since we expect to monitor slowly varying phenomena, the shutter aperture / closing time should not be a limiting factor.

This system operates on one side of the vessel: in order to have a complete determination of the motion of the raster scan, the MA and the SIM, it is necessary to replicate the entire system on a different median plane, orthogonal to the previous one.

		XD1 LS	XD3 LS	XD5 LS	XD6 LS	XD1 LP	XD5 LP	XD6 LP
Linear Measurement								
Measurement Range	0 - 45 m 80 m (optional)	✓	✓	✓	✓	✓	✓	✓
Accuracy	0.2 µm/m					✓	✓	✓
	0.5 µm/m	✓	✓	✓	✓			
Straightness Measurement								
Measurement Range	± 0.3 mm						✓	✓
	± 0.5 mm		✓	✓	✓			
Accuracy	± (0.5 µm + 0.1 µm/m) or 1% of max measured error						✓	✓
	± (1 µm + 0.2 µm/m) or 1% of max measured error			✓	✓			
	± (2 µm + 0.4 µm/m) or 2% of max measured error		✓					

1.3.1.1 Mechanical Ground Support Equipment

The MGSE includes at least the following systems:

- MA cart (MAC): this system is used to insert the Mirror Assembly inside the vacuum vessel. It is equipped with all the degrees of freedom, which are necessary to properly handle the positioning and the alignment of MA inside the vessel without braking the vacuum, including the control of its position on the basis of the measurements made by the metrology system. The concept of operations is the following:
 - o MA arrives at the facility
 - o MA is transported to its ISO-5 room
 - o The gravity release system is transported in the ISO-5 room
 - o The gravity release system is connected to the MA
 - o The assembled system is attached to the MAC, already placed in ISO-5
 - o MAC is moved inside the vessel: the MAC shall be already completely cabled on the vacuum side
 - o MAC position is locked inside the vessel
 - o The adjusters installed on-board the MAC are used to adjust the position of the MA

- SIM cart (SIMC): this system has the same role of the previous one, and it is used for the SIM. A problem area related to this equipment consists in the necessity to provide the suitable interfaces with the cooling systems of the SIM (multi-stage cooling chain). A possible development, which deserves a deep investigation, is that SIMC is equipped with suitable rigid pipelines. One side of the SIMC pipelines are connected with the respective pipelines on-board SIM. This operation can be performed during the installation of SIM on-board SIMC. The other end of the SIMC pipelines shall be connected with vacuum side of a fluid feedthroughs on the vacuum vessel. This shall be accomplished reducing as much as possible the distance between the two and using flexible pipes, limiting as much as possible the intervention of personnel.
- Detector Motion System (DMS): this system is used to control the position of the detector in the working area. Such system can be realized by using a combination of vacuum-compatible commercial linear stages and lift-stages. The large linear range required by the application prevents from the possibility to use a single hexapod.

EIE has considerable experience in the design and construction of these devices. Hereafter the design and the real M1 cart, the device used to remove the 4-meter primary mirror of the DAG telescope. Other MGSE includes all the trolleys, which are necessary to move the equipment inside the clean areas, from the exit of the good lifter to the final ISO-5 room. Handling devices might also include hoists for lifting the MA or other relevant systems.



Figure 1-41. Example of a trolley equipped with motion systems, used to handle the 4-meter primary mirror of the telescope DAG.



Figure 1-42. Commercial motion system that can be used to integrate the DMS.



Figure 1-43. An ISO-5 compatible hoist with 5 tons load capacity.

1.10 POTENTIAL PROBLEM AREAS and TRADE-OFF:

Vacuum Vessel

Table 1-7 provides the main potential problems for the vacuum vessel, while Table 1-8 reports the corresponding proposed solutions.

ID	Problem	Description
1	ISO-5 Continuity	Any access to the vessel shall guarantee ISO-5 continuity between the inner part of the vessel and the clean rooms. This continuity shall be guaranteed by the MGSE used to insert the various sub-systems of ATHENA and the Raster Scan. If the facility operational concept requires the presence of personnel inside the volume of the vacuum chamber during the installation of the MA and the SIM, then in order to guarantee ISO-5 in this situation it is necessary to evaluate the presence of suitable laminar air-flows inside the vessel for the entire duration of operations with personnel.
2	Thermal Control	R16 specifies the required temperature control within the vacuum chamber volume. RD1 provides some detail about the cooling chain of the Focal Plane Assembly. No specific documentation of the thermal interfaces of the MA is available.
3	Shape	Best shape for the vacuum vessels is the cylindrical one, which provides the best structural resistance. Most of the segments constituting the vacuum vessel are cylindrical, except the bottom part which is a rectangular cuboid. This shape reduces the inner volume of the vessel chamber as well as its ground footprint. This creates flat surfaces, to be handled with caution under vacuum.

4	Configuration	Most of high-volume vacuum vessels are generally in horizontal configuration with their global weight discharging on half of the cylinder shape. In this case, configuration is vertical to help the MA gravity release. The four cylindrical segments lie above the rectangular cuboid base with their maximum gravity. A supporting structure cannot be placed just under the cylinders wall due to the XRS presence. The weight can be excessive for the base chamber, and needs to be faced properly.
5	Sealing	Having a height of 20m and a diameter of 4.2m, because of production, transportation, and installations reasons the vacuum vessel is divided into 5 segments. This generates many interfaces with increased risk of vacuum leakage.
6	Installation	Lifting up heavy vacuum segments at high altitude (18m) with a long lever arm due to the facility building requires the use of specific lifting cranes that may not access all facility locations.
7	Atmospheric pressure returning	The action of returning back to atmospheric pressure must be undertaken with extreme caution when dealing with big volumes.

Table 1-7 Potential problems for the vacuum vessel

ID	Problem	Description
1	ISO-5 Continuity	The procedures for the integration shall exclude as much as possible the presence of personnel from the scene. Such approach shall be investigated and analysed in terms of required hardware complexity vs. system reliability.
2	Thermal Control	The vessel shall be equipped with the necessary feedthroughs to provide SIM and MA with the necessary thermal interfaces. The design of the thermal shroud shall aim at achieving full compliance to R16, taking into account the various thermal loads which are placed inside the vessel (X-Ray Source, SIM, MA thermal heaters, etc.).
3	Shape	A rectangular cuboid vacuum vessel of big size similar to the one proposed here has been produced for Arcelor steel coating vacuum line (5x5x8m, 120T, 10 ⁻⁵ mbar, Cockeril Sambre, Belgium). To handle this type of design, deep Finite Element Analysis is needed.
4	Configuration	In order to release the weight on the base chamber, an external support structure shall support 3 of the 4 top segments, the 4 th one being the top cover of the entire vessel.
5	Sealing	Sealing are usually obtained by compressing the seal in a shaped groove between two bolted flanges. Due to the vertical configuration of the vacuum vessel, the seal compression cannot be achieved in its gravity direction. A seal side compression has been thought, which is also easier to maintain.
6	Installation	Because of the unusual configuration of the vacuum vessel, in order to reduce the lever arm, the complete assembly holding structure-vacuum vessel shall be placed as much as possible outside the global test facility building, enhancing also the security aspects.

7	Atmospheric pressure returning	A precise procedure will be written describing the sequence of the valves opening to secure human lives and components.
---	--------------------------------	---

Table 1-8 Proposed solutions for the vacuum vessel problems

RASTER SCAN

Table 1-9 provides the main potential problems for the raster scan, while Table 1-10 reports the corresponding proposed solutions.

ID	Problem	Description
1	Tiltmeters dynamic	Electrolytic tiltmeters are accurate and resolute, but they have slow dynamic response. This response may be too slow for the forcing on the structure.
2	Bearings performance degradation	Performance degradation of the Gimbal mount bearings due to localized wear on rollers and bearing rings caused by the small motion range (± 3 deg).

Table 1-9: Potential problems for the raster scan

ID	Problem	Solution
1	Tiltmeters dynamic	Usage of servoinclinometers, which have high accuracy and quick dynamic response.
2	Bearings performance degradation	Procedure recommendations (periodic high-amplitude oscillations), use of sliding bearings or flexures.

Table 1-10: Proposed solutions for the raster scan potential problems

As it regards the tiltmeter dynamics (problem 1), electrolytic tiltmeters have high accuracy and resolution, but they have a time constant in the order of few seconds, which may be too slow. The following apply:

1. The main forcing on beam alignment are the guideline shape errors and the bridge bending during the X-Y motion.
2. The bridge bending has a characteristic wavelength equal to the bridge span (ca. 4000 mm).
3. The linear guides shape error has characteristic length in the order of 250 mm. Since it has shorter wavelength than the bridge bending, it is the critical forcing on the tiltmeter.
4. The scanning speed will be an outcome of the scanning procedure trade-off, but it is likely to be in the order of few mm/s.

Considering a scanning speed of 10 mm/s, and a tiltmeter time constant of 2 s, it results that the linear guides' characteristic frequency is 0.04 Hz and that the response of the tiltmeter — considered as a first-order instrument — is ca. 90% of the input signal. With a time constant of 0.5 s (that of Jewell model 755-high-gain), the response goes beyond 99% of the input signal.

This means that electrolytic tiltmeters are fast enough to capture the forcing on the structure, thus they have been chosen as baseline for the tender. An optical metrology system for tip-tilt detection is also envisaged, and it will act together with the tiltmeters to increase metrology performance.

As it regards the bearings performance degradation (problem 2), the small motion range (± 3 deg) prevents the rollers inside the bearings to make complete revolutions and thus to wear out uniformly. Moreover, if the bearing is grease-lubricated, incomplete revolutions prevent the lubricant to distribute over all the contact surfaces. The result is localized wear on both the rollers and the bearing rings, which leads to increased static friction and difficulty in motion control.

Possible solutions are:

- Executing periodic high-amplitude oscillations of the Semurier truss, in the order of ± 30 deg. This should cause the internal rollers to make some complete revolutions, levelling out the wear.
- Using sliding bearings (i.e. bearings without rolling elements). This class of bearings are much less sensitive than roller bearings to the issue of the localized wear.
- Using flexures (e.g.: Riverhawk flex pivot), which are completely free from wearing issues.

Figure 1-44 shows an example of flexure bearing (Riverhawk flex pivot, series 5000), while sec. Error! Reference source not found. discusses the trade-off to be performed on the Gimbal mount bearings.



Figure 1-44: Example of flexure bearing (Riverhawk flex pivot, series 5000).

TRADE OFF

Raster scan mechanism

The following tables report the main trade-offs to be performed on the Raster Scan mechanism. Other trade-offs could be identified on the basis of ESA recommendation in the early design phase.

ID	Trade-off	Choices/Comparison	Selection for proposal
1	Scanning procedure	<ul style="list-style-type: none"> • Continuous • Stepwise 	Continuous, but with the machine capable of operating also stepwise.

The most important trade-off for the raster scan is the scanning procedure, if it shall be continuous or stepwise. Continuous scanning performs the mirror test while the Xray beam is moving at constant speed, while stepwise scanning performs the test only when the Xray beam has stopped and dampened down all the oscillations.

In general terms, continuous scanning allows a more uniform characterization of the mirror, but it requires quicker sensors, stronger motors, and it reaches a poorer beam alignment.

In the trade-off, the following aspects shall be taken into account:

- Test scheduling and time constraints, the stepwise scanning being much more slow and time-consuming.
- Beam alignment resolution and accuracy, the stepwise scanning having higher performance (the measurement is quasi-static).
- Stiffness and dynamic behaviour of the Semurier truss, in particular the differential translation between the lower part and the upper part due to the inertial forces generated by the motors. Note that the bending of the Semurier truss is downstream the optical metrology, thus it is not seen by

the control system unless tiltmeters are placed next to Collimator and Source (see sec. 1.1.3.2.6.5, error budget case B).

- Natural frequencies of the raster scan, and separation of these frequencies from all the possible exciting frequencies (mainly the linear guides' roughness and irregularity).

ID	Trade-off	Choices/Comparison	Selection for proposal
2	Tiltmeter dynamics	<ul style="list-style-type: none"> • Tiltmeters • Servoinclinometers • Inertial inclinometers 	Electrolytic tiltmeter Jewell 755-high-gain-VAC

As it regards the tiltmeter dynamics, the performance of three types of tiltmeters will be compared:

1. Electrolytic tiltmeters (e.g.: Jewell tilt sensor 755-high-gain), which have high resolution and repeatability but poor dynamic response (time constant in the order of 1 s).
2. Servoinclinometers (e.g.: Jewell series LSOC), which have high-enough resolution and very quick dynamic response.
3. Inertial rotor inclinometers, which are insensitive to linear accelerations since the hinge point is coincident with the centre of mass (thus the inclinometer is perfectly balanced).

In case commercial devices cannot be used because of dynamic response issues, μ CLINE inclinometer can be taken into account. μ CLINE is a special inclinometer developed by EIE for the ALMA project. It is composed by two parts: a servoinclinometer (based on the reverse pendulum concept) and an inertial rotor inclinometer. Both the components are optimized to have high accuracy, high resolution, and quick response. The goal was to measure the wind-induced oscillations on the ALMA antenna.

Figure 1-45 shows some commercial tiltmeters suitable for the application under study, while Figure 1-46 shows the μ CLINE inclinometer and its location in the ALMA antenna.

The baseline for this proposal is the electrolytic tiltmeter Jewell 755-high-gain-VAC (see also sec. 1.2.1.2).

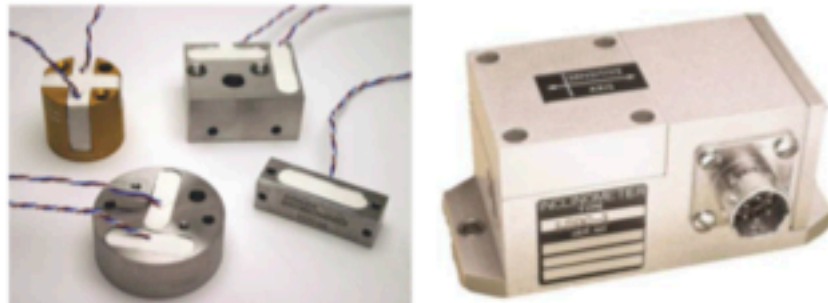

Figure 1-45: Left: electrolytic tiltmeters (Jewell series 755 and 756). Right: commercial servoinclinometer (Jewell series LSOC).

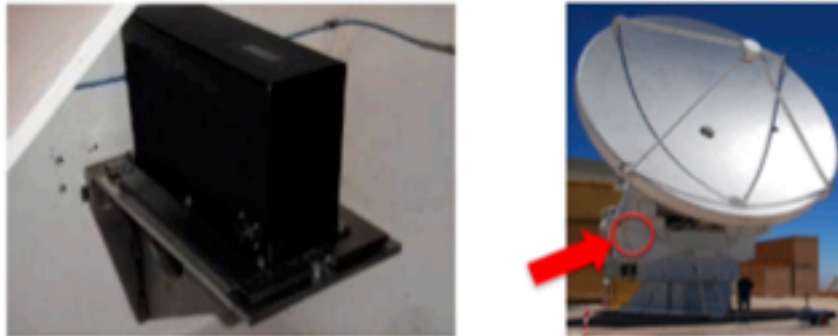

Figure 1-46: μ CLINE inclinometer (left) in the ALMA antenna (right).

ID	Trade-off	Choices/Comparison	Selection for proposal
3	Gimbal mount bearings	<ul style="list-style-type: none"> Ball bearings Cross-roller bearings Sliding bearings Flexures 	Angular-contact ball bearings in martensitic stainless steel (with ceramic balls and phenolic cage) and periodic high-amplitude oscillations of the Semurier truss.

Regarding the Gimbal mount bearings (trade-off 3), the critical aspects that lead the trade-off are the following:

- Vacuum environment, that prevents using standard oils and greases for bearing lubrication (they tend to degas and thus to degrade the vacuum). Possible lubrication alternatives are special vacuum-compatible greases (e.g. Braycote 601eF, based on PerFluorinated PolyEther) or solid lubricants (e.g. Diconite, Graphite, Teflon, Molybdenum Disulfide). Of course, solutions that do not need lubrication (e.g.: flexures) are completely vacuum-compatible.
- ISO5 cleanliness, which requires the sliding or rolling surfaces to produce few micro-particles during the motion. Particle production is particularly important if no grease is used, since the grease tends to capture the wear-generated particles and confine them within the bearing. Again, solutions that do not have rolling or sliding surfaces (e.g.: flexures) do not pollute the clean environment.
- Low angular range (± 3 deg), which prevents the balls or rollers inside the bearings to make complete revolutions and thus to wear out uniformly (both themselves and the bearing rings). Moreover, if vacuum-compatible grease is used, incomplete revolutions prevents the lubricant to distribute over all the contact surfaces. Possible solutions go from operating procedure recommendations (periodic high-amplitude oscillations of the Semurier truss, in the order of ± 30 deg) to the use of flexures or sliding bearings (which are less sensitive than roller bearings to this issue).

ID	Trade-off	Choices/Comparison	Selection for proposal
4	Raster scan and mirror alignment	<ul style="list-style-type: none"> Absolute alignment (w.r.t. gravity vector through some siltmeters) Relative alignment (through some autocollimators) 	Optical metrology for the relative alignment.

As it regards the raster scan vs mirror alignment, two main possibilities will be checked:

1. Independent alignment of both the raster scan and the mirror assembly w.r.t. the gravity vector — which is an absolute reference — thanks to the use of dedicated high-precision siltmeters.

2. Relative alignment of the raster scan and the mirror assembly w.r.t. one another thanks to the use of an autocollimator and dedicated targets. The autocollimator shall be placed on the raster scan, while the targets shall be placed on the mirror assembly.

The absolute alignment w.r.t. gravity does not require new interfaces on the mirror assembly (e.g.: the reflecting target), it is done independently on the various devices, but it requires higher accuracy on the single alignment to reach the same global accuracy on the relative alignment.

The baseline for this proposal is to use optical metrology for the relative alignment (see sec. 1.1.3.8).

ID	Trade-off	Choices/Comparison	Selection for proposal
5	Raster scan fixed part	<ul style="list-style-type: none"> Granite table Stainless steel structure 	Granite table

Two different solutions will be considered for the Raster Scan Base:

- The granite table has high stiffness and high vibration damping capabilities. It also allows a compact design, taking up less space inside the vacuum chamber. The drawbacks are high weight, transportation and handling difficulties, and different thermal behaviour w.r.t. the vacuum chamber (on one side) and the linear guides (on the other side).
- The stainless steel (or aluminium) structure offers high stiffness, low weight, easy transportation and handling. It also allows easy mechanical interfaces to the vacuum vessel and the linear guides. Besides, if stainless steel is used for both the Base and the Bridge, the Base would have the same thermal behaviour as all the elements which is connected to (vessel, linear guides, Bridge), thus avoiding differential thermal expansion among the various components during baking.

The two solutions are both feasible, and they will be assessed in the preliminary design phase. The baseline for the proposal is the granite table.

X-RAY scanning facility

The following tables report the main trade-offs to be performed on the XRS Facility. Other trade-offs could be identified on the basis of ESA recommendation in the early design phase.

ID	Trade-off	Choices/Comparison	Selection for proposal
1	Raster scan position in the vacuum vessel	<ul style="list-style-type: none"> Top Bottom 	Bottom

The proposed raster scan with the Gimbal mount can reverse easily the Xray beam (from directed upward to directed downward): it is sufficient to switch the Xray source and the Xray collimator within each other.

Nevertheless, placing the raster scan on the top of the vessel has strong consequences on:

- The vacuum vessel structure, which would have the biggest and heaviest part on the top.
- The MA gravity release, which would have to work by pulling instead of pushing.
- The Raster Scan optical metrology, which would not have a stable foundation reference next to the Base.
- The assembling, aligning, and maintenance procedures.
- The facility general design — in particular vacuum vessel doors and cleanroom layout — to grant access to the various levels with the proper handling tools.

The baseline for the proposal is with the Raster Scan at the bottom of the vessel and the X-ray beam directed upward. In the early design phase also the reversed configuration will be taken into account, but preliminary considerations say the upward configuration is by far the preferable solution.

ID	Trade-off	Choices/Comparison	Selection for proposal
2	Handling procedure	<ul style="list-style-type: none"> From the top From the bottom From the sides 	From top and side

	• Combination of the 3 first suggestions	
--	--	--

The handling procedure has important consequences on both the experiment set-up time and on the facility layout (in particular on the vacuum vessel doors and the cleanroom scheme). Among the various layout possibilities, at least the following will be compared:

- Overhead crane in cleanroom on the top of the vessel. Not a solution considering the size of the raster scan assembly.
- Lifting system in cleanroom at the bottom of the vessel. Not a solution for the maintenance of the MA, SIM above the raster scan.
- Vacuum vessel completely immersed into an ISO5 cleanroom with a unique overhead crane, with one aperture at every level of interest (raster scan, MA, SIM). Volume of ISO5 cleanroom important with all its disadvantages.
- Vacuum vessel with one aperture at every level of interest, and a small ISO5 cleanroom in correspondence of every aperture. Volume of ISO5 more controlled, need of several overhead cranes.

The baseline proposed in this tender consists of a mix of top and side access aiming at reducing the cleanroom volume and the number of cranes (Figure 1-47). Two main clean zones exist:

1. At the top of the vessel for handling the SIM. An overhead crane lifts up the vacuum vessel top, and places it aside. It can then handle the SIM from its position to the other side. Those steps are conducted in a single cleanroom under ISO5 condition, which preserves the vessel from contamination while open.
2. On the side for handling the Raster Scan and the MA. Two side doors are foreseen on the same side of the vessel at the ground floor (for the Raster Scan) and at the first floor (for the MA). Both the Raster Scan and the MA cart move out of the vessel through dedicated rails and extensions, until they come below a common overhead crane. Those steps are conducted in a single cleanroom under ISO5 condition, which preserve the vacuum vessel of contamination while opened.

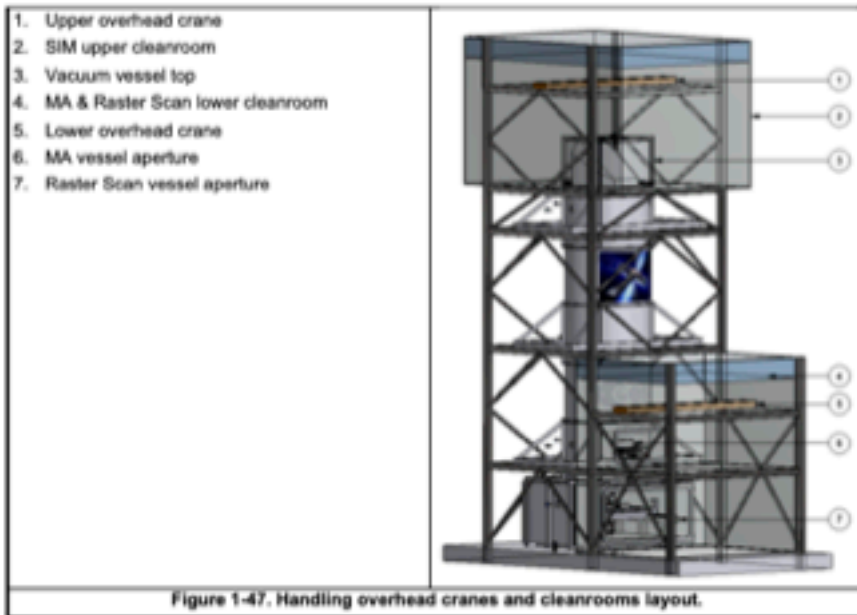

1.11 TECHNICAL COMPLIANCE:

1.11.1 Technical Compliance Matrix (Statement of Work/Technical Requirements)

REQUIREMENT	COMPL. (Y/N/IF)	REMARKS
R001 The XRS Facility shall allow the functional and performance verification of the partially or fully integrated ATHENA MA, as well as its final calibration, by scanning the MA with a vertical small-aperture highly-collimated and actively controlled X-ray beam and collecting the output beam at the focal plane of the MA.	YES	VERT-X will allow us to perform X-ray tests and calibrations with no compromise, since the divergence of the beam is extremely small. Moreover the service X-ray camera that will be used has a very fast read-out, strongly reducing the integration times for achieving a proper statistic of the measurement also when operating in energy dispersive mode.
R002 The XRS Facility shall be able to perform any manipulation of the MA, inside the vacuum chamber, required to satisfy the verification and calibration requirements, without breaking the vacuum. Note: this requirement is schedule-derived, alternative approaches can be proposed if compliance with schedule requirements.	YES	All the components installed within the chamber will comply with operations in vacuum and they will be remotely controlled.
R003 The XRS Facility shall be able to routinely perform beam-characterisation measurements (direct beam on detector) while the MA is in the chamber under vacuum.	YES	For this scope, far-field measurements and beam characterization will be done using the empty circular aperture in the MA structure central part.
R004 The XRS Facility shall provide the possibility to arbitrarily isolate the PSF of each MM.	YES	The parallel X-ray beam can be moved in every position under the MA and so can also provide the measurements of each single MM or groups of MMs.
R005 The scanning speed of the XRS shall be defined following a trade-off between requirement R25 and R50.	YES	A preliminary analysis shows that with the propose opto-mechanical design on can safely operate VERT-X by moving the X-ray collimated beam at a speed of 1 mm/s and, at the same time, to maintain a sufficient flux with respect to the

		envisaged measurement strategy.
R06 The absolute knowledge error of the HEW for the verification and calibration of the MA and for different energies used and off-axis angles shall be ≤ 1 arcsec.	YES	The overall system based on the mechanical components for moving and positioning the parallel X-ray beam (and their associated metrology), the support of the MA, the quality of the collimating X-ray mirror, the pixel size of the service camera, the target of the X-ray source that will be implemented to fulfil the requirements and specs of R06. The errors associated to all these components is < 1 arcsec and, since all sources of errors can be considered independent of each-other, the overall sum is < 1 arcsec.
R07 The maximum effective area loss introduced during verification and calibration of the MA for different energies and off-axis angles shall be $\leq 1\%$.	YES	The divergence of the system is negligible and, in practice, VERT-X is not affected by any area loss due to lack of the second reflection. Moreover, the angle of the beam impinging on the first surface remains the same also for the second reflection. It should be noted that this <u>would not be</u> for a full illumination system also very long (e.g. 800 m), where there is a loss of about 10%.
R08 The absolute knowledge error of the effective area loss introduced during verification and calibration of the MA for different energies and off-axis angles shall be $\leq 1\%$.	YES	See note for R07, the big benefit of the raster scan system here proposed is the extremely low divergence (≈ 1 arcsec) with consequent absence of vignetting.
R09 The X-ray beam collimator system, the MA, and the detector shall be maintained constantly in a closed-loop reference via a metrology system having an accuracy of 50 μ m or better.	YES	This will be obtained by the external metrology devices envisaged to monitor the different stages of the X-ray beam and the MA and SIM supports that will be put in close loop. Moreover, by exploiting the photon counting reading mode of both the X-ray service camera and the ATHENA instruments of the SIM, it would be possible to associate each single focused photon to the position of the X-ray beam.
R10 The closed-loop control system shall feedback information in order to keep X-ray beam, MA and detector/SIM in the required alignment and to consequently allow the automatic tip-tilt adjustment of the collimated X-ray beam (ref. to requirement R30 and R32).	YES	The opto-mechanical system for translating the X-ray beam and the associated control software has been specifically designed for being compliant with R10. It should be noted that also post-facto checks and corrections are possible, since the X-ray cameras will be operated in photon counting mode and it is possible to associate at each photon the positions of the X-ray source during the raster scan and the relative metrological housekeeping data at any instant.
R11 The vacuum chamber shall be designed in a way to contain and structurally support the following three systems, preferably arranged in a vertical configuration, and in sequence as per the following: <ul style="list-style-type: none"> • The X-ray source and collimator system, together with the raster scan system (all to be designed/procured); • The MA (provided by SC-Prime - physical characteristics and interfaces as per [AD1]); • The detector (to be designed/procured) or the SIM (provided by SC-Prime - physical characteristics and interfaces as per [RD7] - [RD9]). 	YES	The proposed configuration of the different subsystems has been designed ad hoc and exactly for this purpose. Moreover, also the building and the equipment have been designed for this scope.
R12 The vacuum chamber shall allow the insertion and removal of the fully assembled MA and SIM.	YES	See note above.
R13 The vacuum chamber shall offer at least an ISO 5 environment in presence of the MA and SIM without their protective cover.	YES	All the components adopted will be compliant with this requirement. The proposed building configuration has been specifically designed for the scope.
R14 The vacuum chamber shall offer openings that allow the entrance of operators and GSE as required to perform all the operations necessary to run and maintain the XRS Facility for the execution of the performance verification campaigns for the Qualification Model (QM) and Flight Model (FM) MA and calibration campaign for the FM MA.	YES	See note above.
R15 The vacuum chamber shall be equipped with a vacuum generation system to create an internal pressure down to 10^{-6} Torr and in a time compatible with the foreseen operations necessary to execute the performance verification and calibration campaigns for the GM/FM MA, as per [AD1] (< 1.8 h-URD> tab of the annexed excel file), [RD4] and [RD6]. Goal: pressurisation time should be less than 5 hours.	YES	The proposed system is specifically designed to be compliant.
R16 The vacuum chamber shall be equipped with a thermal control system to keep the internal temperature at $20^{\circ}\text{C} \pm 1^{\circ}\text{C}$.	YES	The proposed system is specifically designed to be compliant with the requirement.

<p>R17 The vacuum chamber should offer suitable windows in correspondence of the collimator, MA and detector/SIM to allow optical metrology to sense inside the vacuum chamber (refer to requirement R9).</p>	YES	<p>The vacuum chamber will be specifically designed in order to fulfil the requirement.</p>
<p>R18 The vacuum chamber shall be equipped with interface flanges to allow power and data cables connection between internal and external GSE during operational (vacuum) and non-operational conditions.</p>	YES	<p>The proposed system is specifically designed to be compliant with the requirement.</p>
<p>R19 The X-ray source and collimator system shall be compatible with operations in high vacuum conditions (as per requirement R15).</p>	YES	<p>The micro-focus X-ray sources considered in the proposal are high-vacuum compatible. The bias supply will be external to the Vacuum tank and a proper wiring system will be used to deliver the high voltage / low current signal to the source. The collimator system is just passive and it can be operated in high vacuum. The substrate will be about 100 mm thick and so not sensitive to the mechanical deformations due to vacuum.</p>
<p>R20 A set of X-ray sources shall be selected to perform the required performance verifications and calibration campaigns of the MA in the ATHENA energy range 0.2-12 KeV as per [AD1].</p>	YES	<p>The possibility of changing the targets will be implemented. The achievable spectra will allow to perform verifications and calibration campaigns of the MA in the ATHENA energy range 0.2-12 KeV. Moreover, it should be noted that the X-ray sources could be operated also with a polychromatic beam (and not just using specific fluorescence lines, as instead usually done for monochromatic measurements). The continuum X-ray bremsstrahlung spectrum depends mainly on the applied bias and on the filters placed on top of the source to clean and tailor the energy spectrum in order to get the desired shape. In this respect, if the polychromatic mode is adopted, the bias will be also remotely controllable and a filter wheel with proper filters will be implemented.</p>
<p>R21 The selected set of X-ray sources shall be integrated in a system that can automatically change the X-ray source to be operated and without breaking vacuum.</p>	YES	<p>This feature will be implemented. BUT: see note above</p>
<p>R22 The X-rays emitted by the source shall be collimated in a beam having the largest cross-section possible.</p>	YES	<p>A trade off taking into account the distance from the source of the parabolic collimating mirror, the reflection angles involved and the reflection coating will be performed to this end.</p>
<p>R23 The collimated X-ray beam shall have a divergence ≤ 1 arcsec.</p>	YES	<p>The collimating parabolic mirror will be manufactured to have a reflecting surface with an $\text{RMS} < 1$ arcsec. The target of the X-ray source is sufficiently small (10 microns or so) to match the plate scale with a divergence ≤ 1 arcsec.</p>
<p>R24 The collimated X-ray beam shall be directed to the plane of the MA, i.e. in the z direction (with reference to the coordinate system in Figure 1 [AD1]).</p>	YES	<p>The VERT-X design has been already conceived 'ad initio' to be compliant with this requirement.</p>
<p>R25 Sufficient X-ray flux shall be generated to characterise the local PSFs of the MA, without being significantly affected by statistical uncertainties.</p>	YES	<p>The X-ray source operated in both fluorescence lines and polychromatic mode will have a very high flux, in particular in correspondence of all energy values indicated so far as the baseline of calibrations. The high photon flux, together with the fast service X-ray camera, will allow to characterise the local PSFs of the MA in a very short time (a few minutes for each MM). So R25 is met.</p>
<p>R26 The beam homogeneity in flux shall be $\leq 3\%$, in energy about 5%.</p>	YES	<p>The strategy that will be used for pursuing the calibrations using polychromatic beam foresees:</p> <ul style="list-style-type: none"> - measuring different portions of the Effective Area vs. Energy profiles in separate runs with different input spectra - the X-ray spectrum for each run will be properly set taking into consideration target, applied bias, reflecting angles of the collimating mirror and filters in order to achieve the requirement. <p>While this requirement is fulfilled, it should be noted that the measuring strategy seems already redundant with respect to</p>

		R24. Since X-ray cameras with a high energy resolution and high angular resolution will be used for VERT-X, then the detector system would itself be able to disentangle and normalize in the proper way possible differences in the homogeneity of the beam, provided that the flat field is well characterized.
R27 The absolute knowledge error of the flux during the scan of the whole MA shall be $\leq 3\%$.	YES	The strategy used by VERT-X for measuring the flat field (in the empty circle at the centre of the MA) will allow us to know very well the input flux. Moreover X-ray sensors will be used to continuously monitor the flux using a small portion of the beam after the X-ray mirror collimator, as done at e.g. Pando and Synchrotron facilities.
R28 The temperature of the operating X-ray source shall be kept stable in the range $20^{\circ}\text{C} \pm 1^{\circ}\text{C}$, e.g. with a thermal shroud, and constantly monitored during operations.	YES	A proper temperature control system for the X-ray source will be implemented, based on thermal pipes to cool down the system. The thermal shroud of the vacuum chamber is designed in such a way to achieve compliance with R16, taking into account the thermal load generated by every heat source, including the X-ray source.
R29 The X-ray source and collimator system shall be mounted on a (x, y) translation stage (with reference to the coordinate system in Figure 1), which shall be compatible with operations in high vacuum conditions (as per requirement R15).	YES	VERT-X design has been already conceived "ab initio" to be compliant with this requirement.
R30 The positioning of the X-ray beam (i.e. the X-ray collimator) shall be controlled by an external metrology system, as defined in RS.	YES	VERT-X design has been already conceived "ab initio" to be compliant with this requirement.
R31 It shall be possible to tip-tilt the direction of the collimated X-ray beam in a range of $\pm 3^{\circ}$ around the z-axis (as per reference system of Figure 1), with an accuracy of 1 arcsec, during operation in vacuum, with a tip-tilt automatic control system.	YES	The collimating mirror and X ray source can be properly oriented in order to fulfil this requirement.
R32 The tip/tilt of the X-ray beam shall be controlled rapidly enough to maintain the require alignment - verticalisation of the beam with the MA and the detector/SIM in a dynamical way during the raster scanning.	YES	VERT-X design has been already conceived "ab initio" to be compliant with this requirement.
R33 It shall be possible to translate the X-ray beam in x and y direction in order to perform a complete raster scan of the MA with a min step resolution ≤ 0.05 mm and with an accuracy ≤ 0.02 mm.	YES	VERT-X design has been already conceived "ab initio" to be compliant with this requirement.
R34 The XRS Facility shall offer suitable mechanical interfaces to sustain the MA, in compliance with [AD1], and preferably with the MA optical axis in vertical direction, i.e. in the z direction.	YES	VERT-X design has been already "ab initio" conceived to be compliant with both the requirement and the "nice to have" request, respectively.
R35 The XRS Facility shall also offer a removable gravity-release structure/mechanism to counteract the gravity effects on the MA structure in accordance with [AD1].	YES	A proper study is being performed by BCU-Progetti in order to simulate the effects of gravity on the MA mounted in vertical configuration, based on the MA design and on the fully populated FEM made available. The study will evaluate the expected optical performance with ray-tracing simulations using the results of the FEM study as an input. This will allow a design of an "ad hoc" gravity-release actuation stage to counteract the gravity effects.
R36 The XRS Facility interfaces to the MA shall be equipped with a thermal control system, e.g. with a thermal shroud, capable, during vacuum operations, to keep the temperature of the MA stable and controlled in the range $20^{\circ}\text{C} \pm 1^{\circ}\text{C}$.	YES	A proper thermal control system will be implemented. It will also be discussed with ESA the opportunity, after a proper analysis, to use directly the thermal control system that will be used for the MA during the ATHENA operations in space.
R37 The XRS Facility shall offer suitable mechanical interfaces to structurally sustain the SIM, in accordance with [RD7] - [RD9], and to allow to align it with the MA optical axis as per flight configuration requirements, in compliance with [AD1].	YES	VERT-X design has been already conceived "ab initio" to be compliant with this requirement.
R38 The detector shall be compatible with operations in high vacuum conditions (as per requirement R15).	YES	The service X-ray camera envisaged in the proposal for the calibration of the MA has been specifically developed to work in high vacuum ($\leq 10^{-7}$ Torr). Also the front end electronics is designed to work in high-vacuum environment.
R39 The detector and its (x, y, z) stage shall be designed in compliance with the requirements in [AD1], and with reference to [RD3], [RD4].	YES	VERT-X design has been already conceived "ab initio" to be compliant with this requirement.
R40 The detector shall be placed at the focal plane of the MA.	YES	VERT-X design has been already conceived "ab initio" to be compliant with this requirement.

R41 The detector shall be mounted on a high-vacuum compatible (x, y, z) translation stage, for focus alignment (by adjusting position in the z-direction, i.e. along the direction of the optical axis of the MA), and for out-of-field acquisitions (by moving the detector on the xy plane).	YES	VERT-X design has been already conceived "ab initio" to be compliant with this requirement.
R42 The detector (x, y, z) stage shall move in the z-direction of at least ± 50 mm, with steps of 0.25 mm or larger, and with an accuracy ± 0.25 mm.	YES	VERT-X design has been already conceived "ab initio" to be compliant with this requirement.
R43 The detector (x, y, z) stage shall have sufficient translation range in the x and y direction to allow out-of-field measurements up to at least ± 180 arcmin, and with a positional accuracy ± 0.03 mm.	YES	VERT-X design has been already conceived "ab initio" to be compliant with this requirement.
R44 The XRS Facility shall be equipped with systems (e.g. crane) and suitable interfaces to lift and manoeuvre MA and SIM to be placed in the vacuum chamber and fixed in their respective positions.	YES	Proper cranes, compliant with the environmental standards, will be adopted for handling the MA and SIM modules.
R45 The Contractor shall foresee and report all the optical, mechanical, electrical and electronic equipment needed to run the XRS Facility as a stand-alone facility, including computer systems to control any operation and to acquire and store testing data.	YES	The TN documentation to be delivered will report on all the optical, mechanical, electrical and electronic equipment needed to run the XRS Facility as a stand-alone facility, including computer systems to control any operation and to acquire and store testing data.
R46 The XRS Facility infrastructure shall include, in addition to the vacuum chamber, at least: <ul style="list-style-type: none"> • An air-lock/clean-room ISO 5 connected with the vacuum chamber; • A room for the receipt, storage and handling of the MA and SIM (dimensions of MA container reported in [AD1], for SIM refer to [RD7] - [RD9]); • A control room for operating and controlling the XRS and the vacuum chamber and for data collection; • A meeting room for at least 20 people; • Offices and rooms as needed to support the foreseen operations and operators. 	YES	All aspects concerning this requirement have already been taken into account and they are already included also in the preliminary design of the building.
R47 The XRS Facility shall be designed as a stand-alone outdoor building.	YES	The proposed VERT-X design is based on a stand-alone outdoor building.
R48 The design of the XRS Facility infrastructure shall not be dependent on a specific location/site.	YES	The proposed VERT-X design does not depend on any specific location or site. The reference rooms for the design of the facility (building, plants, etc.) are Eurocodes https://eurocodes.jrc.ec.europa.eu/
R49 The MA and SIM shall be handled, if outside of the transport container and without protective covers, in an ISO 5 (at least) environment at all times.	YES	The building, the clean rooms and the cranes have been designed for being able to handle the SIM and, at the same time, to maintain at least an ISO 5 environment at all times.
R50 The XRS Facility shall allow to execute the performance verification campaign tests for the MA QMFM verification campaign, and the calibration campaign for the MA FM, in the modality and schedule as required in [AD1], with reference also to [RD4] and [RD5].	YES	VERT-X is specifically designed to allow to perform all the X-ray calibrations regarding the ATHENA MA. The intense X-ray flux, together with the high velocity readout of the service X-ray camera will allow us to perform the calibrations in in the modality and schedule as required in [AD1], with reference also to [RD4] and [RD5].
R51 The XRS Facility design shall be compliant with the European safety regulations.	YES	VERT-X will be designed to be compliant with the European safety regulations. See also R48.
R52 The useful lifetime of the XRS Facility (equivalent to full life) is the sum of operational life and shelf life. The XRS Facility useful lifetime shall be a minimum of 15 years considering an average usage of the XRS Facility of about seven (7) months/year, i.e. about 1000 hours/year, and considering regular maintenance as required by the different items.	YES	As regular maintenance is foreseen, VERT-X will be able to have a lifetime of a least 15 years. However one should take into account that the X-ray source should be changed every couple of years because the target performance tends to degrade for the consumption of the target.
R53 The XRS Facility shall allow preventive maintenance to maintain the functions and performances of the system during its lifetime.	YES	The proposed facility has been conceived taking into account also the regular maintenance operations.
R54 The XRS Facility design shall favour the procurement of parts from European manufacturers, manufactured in Europe or at least available in Europe.	YES	The large majority of the components will be based on European manufacturers. BTW, all parts will be available in Europe and they will not be subject to limitations for purchasing, since they are already used just for civil and scientific applications, with not commercial limitations due e.g. to ITAR. Spare solutions will be envisaged and discussed with ESA in case of components manufactured outside Europe, in particular for the X-ray source and X-ray service camera.

2 IMPLEMENTATION STRATEGY AND PROGRAMME OF WORK

2.1.1 Proposed Work Logic

The proposed work organization applies the structure of activities detailed in the SOW [AO1]. The activities will be performed in a close interaction with ESA, with the possibility to adapt and redirect the activities execution at each review according to the investigations results, following ESA indication and only after ESA Authorization to proceed. A 'design-to-cost' approach is adopted for the identification of 'cost-effective' solutions. Cost drivers will be highlighted and attention drawn on possible cost savings measures. The technology readiness status, development effort, the overall development plan together with the cost estimates will be considered along the study, driving to the establishment of the design and the interface requirements.

TASK 1: Requirements Specifications and Conceptual design

• Task 1.1: Requirement Specifications:

- Subtask 1-1: XRS detector & liaison facility requirement w.r.t ATHENA calibration needs;
- Subtask 1-2: XRS Housing structure requirements review
- Subtask 1-3: XRS source requirements review

Output:

- o D1 : "Requirement Specification Document"

• Task 1.2: Conceptual Design

- Subtask 1-1: XRS detector & raster scan strategy trade off and conceptual design;
- Subtask 1-2: XRS housing structure & raster scan trade off and facility conceptual design;
- Subtask 1-3: XRS source trade off and conceptual design.

Output:

- o D2: "Conceptual Design Review"
- o D3 : "Trade off Report"

N.B.: Milestone at end of Task 1: Requirement Specification and conceptual Design Review (SRR)

TASK 2 : Preliminary Design:

- Subtask 2-1: XRS detector preliminary design and finalization of XRS preliminary design
- Subtask 2-2: XRS housing structure & raster scan preliminary design
- Subtask 2-3: XRS source preliminary design

Output:

- o D4 : "Preliminary design document"
- o TN1. Vacuum Chamber
- o TN2. X-ray Source and Collimator System
- o TN3. Raster Scan System
- o TN4. MA and SiM mechanical support and MA thermal system
- o TN5. X-ray detector and (x, y, z) stage
- o TN6. Gravity Release Structure/Mechanism;
- o TN7. Metrology System
- o TN8. Ground Segment Equipment
- o TN9. XRS Facility Infrastructure
- o TN10. Interface Specifications
- o TN11. Concept of Operation
- o TN12. Technical Budgets
- o TN13. Requirement Compliance Matrix
- o TN14. Product Tree

- o TN15. Critical Item List

N.B.: At end of Task 2: Preliminary Design Review (PDR) milestone will be achieved

TASK 3 : Detailed Design:

- Subtask 3-1: XRS detector detailed design and finalization of XRS final design
- Subtask 3-2: XRS housing structure & raster scan detailed design
- Subtask 3-3: XRS source detailed design

Output:

- o D5 : "Detailed design document"
- o Technical Note updates

TASK 4 : Development plan and cost estimates:

- Subtask 4-1: XRS detector development plan & overall cost evaluation
- Subtask 4-2: XRS XRS overall development plan and support cost evaluation for the XRS infrastructure
- Subtask 4-3: Support development plan and cost evaluation for XRS source

Output:

- o TN16. Development Plan
- o TN17. Schedule estimate for the XRS Facility development
- o TN18. Cost estimate for the XRS Facility development
- o TN19. Schedule estimate for the MA QMFM verification and calibration campaign
- o TN20. Cost estimate for the MA QMFM verification and calibration campaign
- o TN21. XRS Facility User Manual
- o FR. Final Report
- o SR. Summary Report

2.2 Project Organization

2.3 Project organization
2.3.1 Project Team

To perform the work proposed in response of the ESA AO/1-9549/18/NL/AR a team, under the leadership of INAF, has been formed based on a highly sophisticated, recognised and motivated group of experts from the following Institutes and Companies:

- INAF with both Institutes located in Milano (Italy) (OAB – Osservatorio Astronomico di Brera – and IASF – Istituto di Astrofisica Spaziale)
- EIE Group – Mestre (Italy)
- Media Lario (Bosisio Parini, Italy)
- GP Advanced Projects Srl - Gussago (Brescia, Italy)

Moreover, BCV Progetti srl (Milano, Italy) will provide external services to INAF concerning FEM analysis and optical simulations

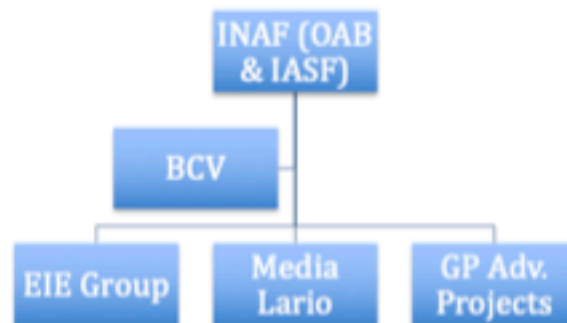

Fig. 2-1. Project team.

This industrial team is therefore composed of first-class partners covering all the critical processes that XRS facility requires. In this proposal INAF leads a comprehensive industrial and scientific team covering all the expertise in the development of a specific X-ray facility for characterize the ATHENA's x-ray optics:

- INAF-Osservatorio Astronomico di Brera (OAB), with responsibility of Project Management, in requirements analysis, X-ray collimator design, X-ray optics characterization
- INAF-Istituto di Astrofisica Spaziale e Fisica Cosmica (IASF), with responsibility of defining the trade-off of the X-ray service camera

Media Lario, well known to ESA for as a leader of the production of X-ray astronomical optics in Europe (and already in charge of the integration of the Athena MM in the MA) will be responsible for the design and optimization of the X-ray system (including the X-ray source, the collimating mirrors, the filters) .

EIE (European Industrial Engineering) Group, leader in the design and manufacturing of Astronomy and Astrophysics observatory, with responsibility for the system design of the XRS facility and infrastructure, including source raster scan and metrology. EIE Group is also responsible for the design of the building and of the related infrastructures.

GPAP, with its experience in ESA and other space-related projects management, will support INAF project in schedule, deliverables costs management and detector (x,y,z) stage.

BCV Progetti has a large experience in the design, FEM analysis and ray-tracing simulations of X-ray optics, having pursued important activities for ASI and ESA in the BeppoSAX, JET-X/Swift, XMM-Newton, Simbol-X and IXO projects.

The members of the proposed organization have a well proven experience of joint collaboration in previous important project like e.g. Beppo SAX, JET-X/Swift and XMM (involving the INAF Institutes, Media Lario and BCV progetti), ASTRICTA (involving involving the INAF Institutes, Media Lario and BCV Progetti and the EIE Group).

A detailed description of the experiences and capabilities of INAF (OAB and IASF) and all its subcontractors is presented in ANNEX 2, including also the facilities operated by these Institutes and Companies. The location of Prime and Subcontractors in the area around of North Italy assures an easy and cost effective coordination / integration of the activities especially, allowing us the opportunity of frequent F2F meetings. All these Institutes & industries are economic entities registered in ESA with proper bidder code. Hereafter a short description of their background is given.

2.3.1.1 Background of the companies

In this section a synthetic profile of the main contractor and its subcontractors is presented, evidencing the background experience in the field of this technology. A detailed report about the experiences and

organization of each Institute and Company, including an extended description of their facilities, is presented in the Annex 1.

INAF - Milano (Brera Astronomical Observatory and IASF-MI)

The two INAF Institutes have a very large experience in the participation in X-ray astronomical projects and, in particular, in the field of X-Ray optics. Beppo-SAX, Jet-X, XMM, SWIFT, INTEGRAL, AGILE are only some of the X-Ray satellites whose X-ray Instruments and Mirrors have been basically developed, designed, simulated and supported by these centres of excellence. They are already deeply involved in the activities in preparation of the ATHENA mission concerning both optics and mirrors. They have already led activities funded by ESA. INAF has firstly proposed the XRS concept to ESA. Moreover INAF is responsible of BEATRIX (Beam Expander Testing X-ray Facility) for testing ATHENA's SPO modules.

Media Lario

Media Lario is specialized in design, manufacturing and testing of lightweight opto-mechanical systems and was founded to develop the Ni-Electroforming technology, for the mirror shells of the XMM-Newton Telescope. MLT has already performed design studies on the XEUS mirror plates and produced prototype plates by using its core technology. Today, MLT is also studying and experimenting with different mirror technologies including glass and ceramic substrates. MLT is a leading supplier of high-precision reflective optical components and systems, serving the desired radiation spectrum from X-ray to millimeter waves. Leveraging more than 10 years of experience and success in Space & Terrestrial precision optics, MLT is now well positioned to become a key supplier of cost effective and thermally demanding precision optical components and systems for: Semiconductor Lithography, Semiconductor Processing Capital Equipment, Space & Terrestrial Telescopes, Medical & Life Science Devices. It is the industrial responsible for the Simbol-X, e-Rosita and Magic II mirror production.

EIE Group

EIE GROUP is an engineering company, an excellence in the Italian Industrial panorama, leader in Management & Contracting, Engineering & Design, Production & Services, operating in the fields of Astronomy and Astrophysics and the Big Science, besides producing machines, equipment and integrated systems for the industry and the scientific research fields. The company, on the international scene for more than 25 years, has focused on the development of industrial and civil projects becoming a leader in the production of Telescopes, Radio-telescopes, Astronomical Observatories and scientific equipment, with focused engineering assets and solid know-how in fabrication and assembly processes, as well as in mechanisms and plants management. EIE GROUP delivers integrated engineering and project management services, as well as bespoke products for the industry and otherwise. The main participation concern the ALMA, VLT, NTT, VST and VISTA, ASTRUCITA, LSST where the company took the responsibility of the design of telescopes and building and to manage their manufacture.

BCV Progetti

BCV Progetti was established in 1973 by: G. Ballo, G.Colombo and A. Vintari. BCV progetti s.r.l. is an engineering firm dealing with projects and subsequent realisation of civil and mechanical works as buildings, machinery, concrete, steel and other material structures and with a wide and long experience in the astronomy and space components. Starting from the finite element analysis of an 8 meter diameter light weighted steel mirror blank for the Very Large Telescope (VLT) – 1985 some other example are the Structural analysis and performance prediction of the mirror module and mirror shells for X ray telescope of XMM Project; the Phase A structural design and optical performance analysis of the Mirror Module of SIMBOL-X mission (2008). They have been already involved in the activities in preparation of the ATHENA mission concerning the FEM analysis of the MA.

GP Advanced Projects

GP Advanced Projects, is a small innovative start up focused on developing innovative projects about cutting edge technologies in the space field, in helping non-space companies in entering the space sector and in the commercialization of engineering products. Thanks to its experience in project management and bid management, GP Advanced Projects not only offers consultancies to help companies in entering

the space field, but it also provides support in designing and developing space components and systems, in the mechanical, thermal and propulsion fields. The company is also active in the development of nanosatellite subsystems for IOV/NOT activities.

2.4 Organisation, Responsibility and Key persons

The team has assigned to the project qualified personnel with recognized experience that is committed to the accomplishment of the project. The list of key personnel for the project, their affiliation and position inside the company/institute is detailed in and Table 2-2 show the time allocation estimated with respect the project duration and with respect to the hours for each WP or the total hours of the project.

For the execution of this project INAF-OAB will have a dedicated project manager (Alberto Moretti) who will coordinate an internal team of skilled process, engineers and technicians, as well as the external supply chain and test facility. The project manager will also be the liaison and main contact point with the Agency and will involve the appropriate internal personnel and suppliers for the required technical discussions. The Quality and Product Assurance function (taken by Nicola La Palombara) and the System Engineer (Stefano Basso) will support the project manager for the quality aspects of the project. A Senior Advisor (Giovanni Pareschi) will continuously follow the activity and support the PM. The INAF team will be completed by the Camera Engineer (Michela Uslenghi), Giorgia Sironi (responsible for the optical configuration) and Rachele Mikul (configuration manager). Finally the OAB/INAF Director, Gianpiero Tagliatemi, will also monitor the activities and will take care of ensuring an effective management of the administrative activities. It should be noted that the INAF team is composed of persons with a very high experience in the field of X-ray optics and instrument development, simulation and calibrations.

Dr. Massimiliano Tordi, physicist and astronomer, will lead the team of EIE Space Technologies Srl. Mr. Francesco Rampini will be responsible for the development of the XRS facility, coordinating the team dedicated to the design of the facility, including plants. Mr. François Dury will be responsible for the team dedicated to the development of the mechanical design, including mechanisms. The Finite Element Modelling group will be led by Mr. Stefano Mian, while Dr. Enrico Marcuzzi will be responsible for the team dedicated to the control systems, including metrology. Mrs. Maria-Cristina Gazzato will support for the contractual aspects with the Prime Contractor.

For Media Lario, the design and optimization of the X-ray system will be coordinated by Fabio Zocchi, with the strong support by Giuseppe Valsecchi. They are very skilled engineers, with a an experience of more than 20 years in the field of X-Ray optics. The GPAP contribution will be coordinated by Guido Parisenti, with already an important experience in coordinating space-related activities.

In managing the contract, the PM will have the full control of, and responsibility for task assignments, technical support, production, subcontracts and he will act in close collaboration with the Director of OAB/INAF, who will be kept informed also about all the administrative matters. The Senior Advisor will give a continuous support to the PM for all the strategic decision to be taken.

The project is managed through a project plan, which is maintained throughout its life. The project plan is based on the WBS. The WBS provides a logically ordered set of WPs through which all work on the project will be carried out. Each WP is assigned a budget, derived from the cost model. All charges to the project are posted to a specific WP allowing the accumulation of costs by WP as the work progresses. Individual WPs have a WPM who makes specific work assignments to specific individuals. The WPM is accountable to the PM for schedule and cost. Earned value is established for each WP and used to monitor cost and schedule against performance. Deviation from the baseline would signal the need for management response.

The project status reports are produced by the PM on a monthly basis. They show the technical, schedule and budget status of all WPs in the project, including the managements of risks.

External subcontractors are managed by the PM. INAF-OAB maintains full management, technical and contractual responsibility for the entire project. All subcontractors are defined by a formal subcontractor document which includes a SOW and a technical specification, under configuration control, and is designed to meet its obligations to the customer. All appropriate terms and conditions in the INAF-OAB contract will be transferred down to the subcontractors.

INAF-OAB will implement in its location of Merate (Lecco) a room where all the persons of the PO will be located with project dedicated facilities (computer, phone /fax/ e-mail etc)

No flight Hardware or Software systems are expected to be produced during this project. Nevertheless the "qualification" of the designs, the choice of the materials and all the trade-off request a particular attention in terms of PA/QA in view of the final scientific calibrations of ATHENA in X-rays. The INAF-OAB PA and QA are adequately supported with a specifying person looking after these aspects.



Fig. 2-2: Project organization, Responsibility

2.5 TEAM ORGANISATION AND PERSONNEL

2.6 Overall team composition, Key Personnel

In table 2.1 we report the overall team composition, with key persons indicated in Bold. The curricula of the key persons are included in the ANNEX 2. It should be noted that the team is formed by people with a very high experience in running space and astronomical programs, with already a well consolidated collaboration with ESA (with a particular great know-how specifically developed for the development and calibrations of X-ray optics and instruments and with an already solid knowledge of the ATHENA mission) or other big international organizations like ESO.

Table 2-1 Overall team composition. Key persons are indicated in Bold

Name	Affiliation	Position within the company	Role in the project
Alberto Moretti	INAF-OAB	Senior Researcher	Project manager; resp WP 5100
Giovanni Pareschi	INAF-OAB	Senior Researcher	Senior Advisor
Giorgia Sironi	INAF-OAB	Senior Researcher	Resp. WP1120, 2020, 3020,4020
Gianpiero Tagliaferri	INAF-OAB	Senior Researcher and Director	Support WP 5100
Stefano Basso	INAF-OAB	Senior Technologist	System engineer
Bianca Salmasso	INAF-OAB	Senior Researcher	Support WP1120,2020,3020,4020
Marta Civitani	INAF-OAB	Senior Researcher	Support WP1120,2020,3020,4020
Rachele Millù	INAF-OAB	Management	Support WP 5100, 5200
Michela Uslenghi	INAF-IASF-MI	Senior Researcher	Resp. WP 1110
Nicola La Palombara	INAF-IASF-MI	Senior Researcher	Resp WP 5200
Mauro Fiorini	INAF-IASF-MI	Senior Researcher	Support WP1120,2020,3020,4020
Franco Amisano	GPAP	Technical Office	Resp. WP5300
Guido Parissenti	GPAP	Program & bidder manager office	Support WP5300
Giancarlo Parodi	BCV	Member of the Board of Directors of the Company	Support WP1120,2020,3020,4020
Giuseppe Valsecchi	Media Lario	Chief Technical Officer	Resp. WP 4030
Fabio Marioni	Media Lario	Senior Optical Engineer	RESP WP 1130, 1230, 2030,3030
Massimiliano Tordi	EIE	Project Manger	RESP WP 1120,1220, 2020,3020,4020
Stefano Mian	EIE	Sr. Structural Engineer	Support WP 1120,1220, 2020,3020,4020
Francois Dury	EIE	Sr. Mechanical Engineer	Support WP 1120,1220, 2020,3020,4020
Enrico Marcuzzi	EIE	Sr. Control System Engineer	Support WP 1120,1220, 2020,3020,4020
Francesco Rampini	EIE	Sr. Mechanical Engineer	Support WP 1120,1220, 2020,3020,4020

2.6.1.1 Time dedication of key personnel

Table 2-2. Work package vs Key personnel time allocation with respect to total working time over the WP duration and on average over 18 months.

Name	WP 1110 h (%)	WP 1120 h (%)	WP 1130 h (%)	WP 1210 h (%)	WP 1220 h (%)	WP 1230 h (%)	WP 2010 h (%)	WP 2020 h (%)	WP 2030 h (%)	WP 3010 h (%)	WP 3020 h (%)	WP 3030 h (%)	WP 4010 h (%)	WP 4020 h (%)	WP 4030 h (%)	WP 5100 h (%)	WP 5200 h (%)	WP 5300 h (%)	Total h (%)
A. Monetti	100 (20%)			100 (20%)			100 (11%)			100 (16%)			100 (40%)			300 (40%)			800 (35%)
G. Pareschi																100 (7%)			100 (4%)
S. Sironi				200 (20%)			200 (22%)			200 (32%)			100 (40%)			100 (7%)			800 (35%)
M. Usenghi	50 (10%)			50 (10%)			50 (6%)			50 (8%)			50 (20%)						250 (10%)
N. LaPalombara																	200 (13%)		200 (8%)
F. Amisano																		143 (6%)	143 (6%)
D. Parisenti																		143 (6%)	143 (6%)
G. Valsecchi						16 (3%)			16 (2%)			16 (3%)			40 (16%)				88 (4%)
F. Marosi			40 (8%)			80 (16%)			122 (14%)			124 (20%)							364 (16%)
M. Todi		10 (2%)			10 (2%)			10 (10%)			100 (11%)				10 (3%)				140 (6%)
E. Mercuri		20 (5%)			30 (5%)			30 (15%)			150 (8%)			20 (7%)					250 (12%)
F. Rampini		40 (9%)			40 (7%)			40 (15%)			150 (11%)			40 (14%)					310 (15%)
S. Milan		40 (9%)			40 (7%)			40 (15%)			150 (11%)								270 (13%)
F. Dury		40 (9%)			40 (7%)			40 (15%)			150 (11%)			40 (14%)					310 (15%)

2.7.1.2 Work Package Description (WPD)

WORK PACKAGE DESCRIPTION		PSS-A-20
PROJECT: X Ray Scan	PHASE: NA	WP REF: 1110
WP Title: XRS detector & lison of facility requirements w.r.t ATHENA calibration needs		Sheet 1 of 1
Contractor: INAF		Issue Ref: 1
Major Constituent: Requirement specifications		Issue Date: 22-Oct-18
Start Event: KOM		Planned Date: 7-Jan-19
End Event: SRR-1 month		Planned Date: 13-Apr-19
WP Manager: Michela Uslenghi		
Objectives: <i>Scope of this activity is to derive the specifications for the detector and for the detector stage and to write the Requirement and Specification Document</i>		
Inputs:		
<ul style="list-style-type: none"> • AD and RD documents identified in the SOW. • Additional inputs provided by the Agency at KOM. • X Ray Scan technical proposal • Contract • Input from WP1120 and 1130 		
Detailed task description:		
<ul style="list-style-type: none"> • Definition of the detector requirements. • Definition of the detector stage requirement. • Collecting inputs from WP1120 and 1130 and writing D1. 		
Outputs:		
<ul style="list-style-type: none"> • D1: Requirement and Specification document 		

=====

WORK PACKAGE DESCRIPTION		PSS-A-20
PROJECT: X Ray Raster Scan	PHASE:	WP REF: 1120
WP Title: XRS housing structure requirement review		Sheet 1 of 1
Contractor: EIE		Issue Ref: 1
Major Constituent: Requirements Definition		Issue Date: 22-Oct-18
Start Event: KOM		Planned Date: 7-Jan-18
End Event: SRR-1 month		Planned Date: 13-Apr-19

WP Manager: Massimiliano Tordi

Objectives: Scope of this activity is to derive the specifications for the X Ray housing structure.

Inputs:

- AD and RD documents identified in the SOW.
 - Additional inputs provided by the Agency at KOM.
 - X Ray Scan technical proposal BD-PO-INAF-xx.
 - Contract.
-

Detailed task description:

- Definition of the housing structure requirements.
 - Definition of the contamination levels compatible with the requirements of ATHENA
 - Definition of the raster scan positioning accuracy requirements
 - Definition of the metrology accuracy requirements
 - Definition of the vacuum vessel thermal control system requirements
 - Definition of the vacuum vessel pumping requirements
 - Definition of the handling procedures requirements
-

Outputs:

- D1 Input to Requirements Specification Document
-

WORK PACKAGE DESCRIPTION		PSS-A-20			
PROJECT:	X Ray Scan	PHASE:	NA	WP REF:	1130
WP Title: X Ray source requirements review		Sheet 1 of 1			
Contractor: Media Lario		Issue Ref: 1			
Major Constituent: Requirement specifications		Issue Date: 22-Oct-18			
Start Event: KOM		Planned Date: 7-Jan-19			
End Event: SRR		Planned Date: 13-May-19			
WP Manager: Fabio Marioni					

Objectives: Scope of this activity is to derive the specifications for the X Ray source and collimator

Inputs:

- AD and RD documents identified in the SOW.
 - Additional inputs provided by the Agency at KOM.
 - X Ray Scan technical proposal
 - Contract
-

Detailed task description:

- Definition of the minimum scanning time for each MM of the ATHENA MA.
- Definition of the minimum reflected photons needed to perform the SPO MM PSF evaluation
- Perform literature survey of already existing X Ray sources with focus on power, emitted photon counts, emission angle.
- Definition of specification for the mirror collimator for a give grazing angle
- Define shape, dimension and optical performances of the mirror collimator

Outputs:

- Inputs to Requirement and Specification Document
Including:
 - X Ray sources state of art
 - Collimator mirror optical model
 - Selection method and criteria.

.....

WORK PACKAGE DESCRIPTION PSS-A-20

PROJECT: X Ray Scan PHASE: NA WP REF: 1210

WP Title: XRS detector and raster scan strategy trade-offs and XRS conceptual design Sheet 1 of 1

Contractor: INAF Issue Ref: 1

Major Constituent: Conceptual Design Issue Date: 22-Oct-18

Start Event: KOM Planned Date: 7-Jan-19

End Event: SRR Planned Date: 13-May-19

WP Manager: Giorgia Sironi

Objectives: *Scope of this activity is the conceptual design of the detector and of the detector stage and writing the Conceptual and Trade-off reports*

Inputs:

- AD and RD documents identified in the SOW.
- Additional inputs provided by the Agency at KOM.
- X Ray Scan technical proposal.
- Contract
- Output of WP 1110, 1220, 1230

Detailed task description:

- Identify on the market the detectors with features which meet the requirement defined in WP 1110
- Analysis of the different characteristics and trade off
- Conceptual design of the detector stage
- Compilation of D2 and D3

Outputs:

-
- D2: "Conceptual design report"
 - D3: "Trade-off Report"
-

WORK PACKAGE DESCRIPTION PSS-A-20

PROJECT:	X Ray Raster Scan	PHASE:	WP REF:	1220
----------	-------------------	--------	---------	------

WP Title:	XRS housing structure & raster scan trade-off and facility conceptual design	Sheet 1 of 1	
Contractor:	EIE	Issue Ref:	1
Major Constituent:	Conceptual Design	Issue Date:	22-Oct-18
Start Event:	KOM	Planned Date:	7-Jan-19
End Event:	SRR	Planned Date:	13-May-19
WP Manager:	Massimiliano Tordi		

Objectives: *On the basis of the analysis on the requirements, the objective of this activity is to identify a conceptual layout of the facility*

Inputs:

- AD and RD documents identified in the SOW.
 - X Ray Scan technical proposal BD-PO-INAF-xx.
 - Contract.
 - D1 Requirements Specification Document
 - Additional inputs provided by the Agency at KOM
-

Detailed task description:

- Development of the conceptual layout of the raster scan
 - Development of the conceptual layout of the metrology system
 - Development of the building conceptual layout
 - Conceptual layout of the MGSEs
 - Vacuum vessel conceptual layout
 - Thermal control conceptual layout
 - Handling equipment conceptual layout
-

Outputs:

- Inputs to Conceptual Design Report and to Trade-off reports
-

WORK PACKAGE DESCRIPTION PSS-A-20

PROJECT:	X Ray Scan	PHASE:	NA	WP REF:	1230
WP Title:	X Ray source Trade Off and conceptual design			Sheet 1 of 1	
Contractor:	Media Lario				Issue Ref: 1
Major Constituent:	Conceptual Design				Issue Date: 22-Oct-18
Start Event:	KOM				Planned Date: 7-Jan-19
End Event:	SRR				Planned Date: 13-May-19
WP Manager:	Fabio Marioni				

Objectives: *Based on the X Ray source and collimator specification, the conceptual design of the X Ray source is selected*

Inputs:

- AD and RD documents identified in the SOW.
- Additional inputs provided by the Agency at KOM.
- X Ray Scan technical proposal.
- Output of WP 1130

Detailed task description:

- Identify on the market the X Ray sources with features which meet the requirement defined in WP 1130
- Select the mirror collimator concept
- Definition of the mirror collimator geometry
- Verify feasibility, technology and cost for the procurement of the mirror collimator
- Perform a trade-off of the combination system X Ray source/mirror collimator
- Definition of specification for the mirror collimator for a give grazing angle
- Define shape, dimension and optical performances of the mirror collimator

Outputs:

- Inputs to Conceptual Design Report and to Trade-off reports

=====

WORK PACKAGE DESCRIPTION		PSS-A-20			
PROJECT:	X Ray Scan	PHASE:	NA	WP REF:	2010
WP Title:	XRS detector and XRS preliminary design			Sheet 1 of 1	
Contractor:	INAF				Issue Ref: 1
Major Constituent:	Preliminary Design				Issue Date: 22-Oct-18
Start Event:	SRR				Planned Date: 14-May-19
End Event:	PDR				Planned Date: 17-Dec-19
WP Manager:	Giorgia Sironi				
Objectives:	<i>Preliminary design of the detector and of the detector stage and production of the Preliminary design document and Technical Notes TN1-TN15.</i>				

Inputs:

- AD and RD documents identified in the SOW.
- Additional inputs provided by the Agency at KOM.
- X Ray Scan technical proposal.
- Contract
- D2 and D3

Detailed task description:

- Detector performance evaluation and optimization of the readout strategy
- Interfaces definition
- Development of the preliminary design of the detector stage
- Development of the Product Tree to the third level
- Update of the Compliance Matrix
- Definition of the CIL
- ICDs

Outputs:

- D4: "Preliminary Design Document"
- Technical notes: TN5, TN6, TN11, TN12, TN13, TN14, TN15

.....

WORK PACKAGE DESCRIPTION PSS-A-20

PROJECT:	X Ray Raster Scan	PHASE:	WP REF:	2020
WP Title: XRS housing structure & raster scan preliminary design		Sheet 1 of 1		
Contractor: EIE		Issue Ref: 1		
Major Constituent: Preliminary Design		Issue Date: 22-Oct-18		
Start Event: SRR		Planned Date: 14-May-19		
End Event: PDR		Planned Date: 17-Dec-19		
WP Manager: Massimiliano Tordi				

Objectives: *Development of the preliminary design of the XRS housing structure, raster scan and facility.*

Inputs:

- AD and RD documents identified in the SOW.
 - Additional inputs provided by the Agency at SRR.
 - X Ray Scan technical proposal BD-PO-INAF-xx.
 - Contract.
 - D2, D3
-

Detailed task description:

- Development of the preliminary design of the raster scan (3D, FEM, servo analysis)
- Development of the preliminary design of the metrology system (3d, FEM, sensor modelling)
- Development of the building preliminary design (civil works, plants, clean rooms)
- Preliminary design of the MGSEs
- Vacuum vessel preliminary design (FEM, vacuum plants)
- Thermal control preliminary design (Thermal shroud)
- Handling equipment preliminary design

Outputs:

- Technical notes: TN1, TN3, TN4, TN7, TN8, TN9, TN10
- Inputs to TN1-TN15
- Inputs to Preliminary Design Document

WORK PACKAGE DESCRIPTION PSS-A-20

PROJECT: X Ray Scan PHASE: NA WP REF: 2030

WP Title: X Ray source preliminary design Sheet 1 of 1
Contractor: Media Lario Issue Ref: 1
Major Constituent: Preliminary Design Issue Date: 22-Oct-18
Start Event: SRR Planned Date: 14-May-19
End Event: PDR Planned Date: 17-Dec-19
WP Manager: Fabio Marioni

Objectives: *Based on the conceptual design of the X Ray source, the preliminary design of the system source/collimator is prepared*

Inputs:

- AD and RD documents identified in the SOW.
- Additional inputs provided by the Agency at KOM.
- X Ray Scan technical proposal.
- Contract
- D2 and D3

Detailed task description:

- Define shape, dimension and optical performances of the mirror collimator
- Definition of the mirror collimator geometry
- Prepare and release the preliminary manufacturing drawings of:
 - Collimator Mirror,
 - Mirror case,
 - Alignment mechanism,
 - X-Ray source interface,
- Define procurement specs
- Make or buy decision about Collimator Mirror

-
- Select and interface with vendors for:
 - X Ray sources
 - Collimator Mirror
 - Mechanical components

Outputs:

- Technical notes: TN2
 - Inputs to TN1-TN15
 - Inputs to Preliminary Design Document
-

WORK PACKAGE DESCRIPTION PSS-A-20

PROJECT: X Ray Scan PHASE: NA WP REF: 3010

WP Title: XRS detector and XRS detailed design Sheet 1 of 1
Contractor: INAF Issue Ref: 1
Major Constituent: Detailed Design Issue Date: 22-Oct-18
Start Event: PDR Planned Date: 18-Dec-19
End Event: DOR Planned Date: 7-May-20
WP Manager: Giorgia Sironi

Objectives: Detailed design of the detector and of the detector stage and production of the Detailed Design Document

Inputs:

- AD and RD documents identified in the SOW.
- Additional inputs provided by the Agency.
- X Ray Scan technical proposal.
- Contract
- D4: Preliminary Design Document

Detailed task description:

- Preparation of a detailed statement of work for the detector assembly, related cooling, camera control electronics and data acquisition system
 - Detailed design of the Detector stage
 - Development of the Product Tree to the fourth level
 - Update of the Compliance Matrix
 - Update of the CIL
 - ICDs
-

-
- Writing D5

Outputs:

- D5: "Detailed Design Document"
-

.....
WORK PACKAGE DESCRIPTION PSS-A-20

PROJECT:	X Ray Raster Scan	PHASE:	WP REF:	3020
WP Title:	XRS housing structure & raster scan detailed design		Sheet 1 of 1	
Contractor:	EIE	Issue Ref:		1
Major Constituent:	Detailed Design		Issue Date: 22-Oct-18	
Start Event:	PDR	Planned Date:		18-Dec-19
End Event:	DDR	Planned Date:		7-May-20
WP Manager:	Massimiliano Tordi			

Objectives:

- Development of the detailed design of the XRS housing structure, raster scan and facility.
-

Inputs:

- AD and RD documents identified in the SOW.
 - Additional inputs provided by the Agency at PDR.
 - X Ray Scan technical proposal BD-PO-INAF-xx.
 - Contract.
-

Detailed task description:

- Development of the detailed design of the raster scan (3d modelling, FEM, servo analysis)
 - Development of the detailed design of the metrology system (3d modelling, FEM, sensor modelling for servo)
 - Development of the building detailed design (civil works, plants, clean rooms)
 - Detailed design of the MGSEs
 - Vacuum vessel detailed design (FEM, vacuum plants)
 - Thermal control detailed design (Thermal shroud)
 - Handling equipment detailed design
-

Outputs:

- Inputs to Detailed Design Document
-
-

WORK PACKAGE DESCRIPTION PSS-A-20

PROJECT:	X Ray Scan	PHASE:	NA	WP REF:	3030
----------	------------	--------	----	---------	------

WP Title:	X Ray source detailed design	Sheet 1 of 1
Contractor:	Media Lario	Issue Ref: 1
Major Constituent:	Detailed Design	Issue Date: 22-Oct-18
Start Event:	PDR	Planned Date: 18-Dec-19
End Event:	DOR	Planned Date: 7-May-20
WP Manager:	Fabio Marioni	

Objectives: *Based on the preliminary design of the system source/collimator the final and detailed design and drawings are prepared*

Inputs:

- AD and RD documents identified in the SOW.
- Additional inputs provided by the Agency at KOM.
- X Ray Scan technical proposal.
- Output of WP 2030

Outputs:

- Inputs to Detailed Design Document

WORK PACKAGE DESCRIPTION PSS-A-20

PROJECT:	X Ray Scan	PHASE:	NA	WP REF:	4010
----------	------------	--------	----	---------	------

WP Title:	XRS development plan and cost evaluation	Sheet 1 of 1
Contractor:	INAF	Issue Ref: 1
Major Constituent:	Development plan and cost estimate	Issue Date: 22-Oct-18
Start Event:	DOR	Planned Date: 8-May-20
End Event:	FR	Planned Date: 7-Jul-20
WP Manager:	Giorgia Sironi	

Objectives: *: Development of a roadmap for the construction of the XRS facility, including cost evaluation and preparing TN16-21 and Final and Summary reports*

Inputs:

- AD and RD documents identified in the SOW.
- Additional inputs provided by the Agency at KOM.
- X Ray Scan technical proposal.
- Contract
- Detailed Design Document

Detailed task description:

- Negotiate with vendors delivery time and cost for procurement of the detector
- Provision of the cost of the detector stage
- Prepare GANTT for development and implementation of the XRS facility
- Collecting contributes from WP4020 and 4030 to produce TN16-21 and FR and SR

Outputs:

- Technical Notes: TN16, TN17, TN18, TN19, TN20, TN21
 - FR Final Report
 - SR Summary Report
-

.....

WORK PACKAGE DESCRIPTION PSS-A-20

PROJECT: X Ray Raster Scan PHASE: WP REF: 4020

WP Title: XRS overall development plan and support cost evaluation for the XRS infrastructure Sheet 1 of 1

Contractor: EIE Issue Ref: 1

Major Constituent: Development Plan Issue Date: 22-Oct-18

Start Event: DOR Planned Date: 8-May-20

End Event: FR Planned Date: 7-Jul-20

WP Manager: Massimiliano Tordi

Objectives: Development of a roadmap for the construction of the facility, including cost evaluation

Inputs:

- AD and RD documents identified in the SOW.
 - Additional inputs provided by the Agency at DDR.
 - X Ray Scan technical proposal BD-PO-INAF-xx.
 - Contract.
-

Detailed task description:

- Provision of main cost elements. This shall include at least the following cost elements:
 - building (including plants),
 - vessel (including plants and thermal shroud),
 - metrology,
 - Raster Scan,
 - handling equipment and MGSEs
 - detector
 - X-ray source
- Estimation of the Operating Costs
- Provision of a construction schedule

Outputs:

- Inputs to TN16, TN17, TN18, TN19, TN20, TN21, Final Report and Summary Report
-

.....

WORK PACKAGE DESCRIPTION PSS-A-20

PROJECT: X Ray Scan PHASE: NA WP REF: 4030

WP Title: Support development plan and cost estimate for X Ray source Sheet 1 of 1

Contractor: Media Lario Issue Ref: 1

Major Constituent: Development plan and cost estimate Issue Date: 22-Oct-18

Start Event: CDR Planned Date: 8-May-20

End Event: FR Planned Date: 7-Jul-19

WP Manager: Giuseppe Valsecchi

Objectives: *Development of a roadmap for the development of the source and collimator system , including cost evaluation*

Inputs:

- AD and RD documents identified in the SOW.
- Additional inputs provided by the Agency at KOM.
- X Ray Scan technical proposal.
- Output of WP 2030

Detailed task description:

- Prepare GANTT for development and implementation of the X Ray source system
- Negotiate with vendors delivery time and cost for procurement of:
 - X Ray source
 - Collimator Mirror,
 - Mirror case,
 - Alignment mechanism,
 - X-Ray source interface,
- Finalise the procurement specs

Outputs:

-
- Inputs to TN16, TN17, TN18 , TN19, TN20, TN21, Final Report and Summary Report
-

WORK PACKAGE DESCRIPTION PSS-A-20

PROJECT:	X Ray Scan	PHASE:	WP REF:	5100
----------	------------	--------	---------	------

WP Title:	Project Management	Sheet 1 of 1	
Contractor:	INAF OAB	Issue Ref: 1	
Major Constituent:	Project Management	Issue Date: 22-Oct-18	
Start Event:	KOM	Planned Date: 7-Jan-19	
End Event:	FR	Planned Date: 7-Jul-20	
WP Manager:	Alberto Morelli		

Objectives: *Top level coordination of the technical, administrative, and contractual tasks, planning and reporting, liaison with customer, key contributors, and sub-contractors.*

Inputs:

- AD and RD documents identified in the SOW.
 - Additional inputs provided by the Agency at KOM.
 - X Ray Scan technical proposal.
 - Contract.
-

Detailed task description:

- Be the first level contact with ESA for all project related matters including assess to any plan, procedure specification or other documentation relevant to the programme of work.
 - Define, implement, and update the project plan, including dependencies, Gantt chart, milestones, and resource allocation.
 - Coordinate and control the execution of the work packages according to the project plan.
 - Schedule and document periodic internal project review meetings with the WP managers and key project contributors.
 - Schedule and document periodic internal project review meetings with the WP managers and key project contributors.
 - Schedule, organize, and chair the progress meetings and the project reviews with ESA, including the preparation of the deliverable documents, agenda, meeting minutes, and action items.
 - Present the progress reports.
-

Outputs:

- TDP Technical Data Package
 - SR Summary Report
 - ESR Executive Summary Report
 - AB Abstract
 - TAT Technology achievement Template
 - WAT Website Article template
 - FR Final report
 - CCD Contract Closure documentation
 - NCR Non-Conformance Reports (if needed)
 - RFW Requests for Deviation and waivers (if needed)
-

-
- MoM Minutes of Meeting
 - MR Monthly Report
 - SR Schedule Report
 - PD Project Directory
-

WORK PACKAGE DESCRIPTION PSS-A-20

PROJECT: X Ray Scan PHASE: WP REF: 5200

WP Title: Safety and PA Sheet 1 of 1

Contractor: INAF OAB Issue Ref: 1

Major Constituent: Project Management Issue Date: 22-Oct-18

Start Event: KOM Planned Date: 7-Jan-19

End Event: FR Planned Date: 7-Jul-20

WP Manager: Nicola La Palombara

Objectives: *The purpose of the P.A. and Safety WP is to provide guidance as well as support for procurement activities, in order to ensure that they are performed in safe conditions and that the deliverable items are compliant with the applicable requirements.*

Inputs:

- AD and RD documents identified in the SOW.
 - Additional inputs provided by the Agency at KOM.
 - X Ray Scan technical proposal.
 - Contract.
-

Detailed task description:

- Critical Items identification and control
 - Procurement control
 - Test control
 - Accident / Incidents
 - Non-conformance control
 - Acceptance and delivery
-

Outputs:

- QA Reports
-

WORK PACKAGE DESCRIPTION PSS-A-20

PROJECT: X Ray Scan	PHASE:	WP REF: 5300
WP Title: Project Management Assistance & Technical support		Sheet 1 of 1
Contractor: GPAP		Issue Ref: 1
Major Constituent: Project Management		Issue Date: 22-Oct-18
Start Event: KOM		Planned Date: 7-Jan-19
End Event: FR		Planned Date: 7-Jul-20
WP Manager: Guido Parissenti		

Objectives: a) Assist the Program Manager in the execution of his role and in the orientation of the project with respect to the Athena mission status and ESA project management standards. ; b) Assist INAF in the definition of detector (X,y, z) stage

Inputs:

- AD and RD documents identified in the BOW.
- Additional inputs provided by the Agency at KOM.
- X Ray Scan technical proposal.
- Contract.

Detailed task description:

- Prepares, monitors and tracks the project plan throughout its implementation
- Coordinate the execution of the work packages according to the project plan.
- Manages (on behalf of PM) and document periodic internal project review meetings with the WP managers and key project contributors.
- Organizes the progress meetings/project reviews with ESA, including the preparation of the deliverable documents, agenda, meeting minutes and action items.
- Prepare and the progress reports.
- Manages the Project Configuration Control
- Manage, issue, and control ECR, NCR, RFW, and red flag reports.
- Supports to the Project Manager for the subcontractors management,
- Support the preparation the Milestones Data Package
- Support INAF in the definition of detector (x,y,z) stage

2.7.2 Proposed schedule and milestones

Table 2-3 summarizes the tentative dates and location for the KOM, SRR, PDR, DDR, and FR milestone reviews, and for the Final Presentation. The plan assumes a contract start date (KOM) **no later than January 7th, 2018**. The project will be executed in a coordinated and controlled fashion, taking also into account the action items and recommendations provided by the Agency during the project. Moreover, in order to ensure constant alignment with the Agency, the work progress will be monitored throughout the contract duration and periodically reported to the Agency by means of monthly progress reports.

Table 2-3 Progress and milestone review meetings

Reviews	Code	Location	Timing	Tentative Date
Kick-off	KOM	Telecom	T0	January 7, 2019
Requirement Specification and Conceptual Design Review	SRR	INAF	T0+4m	May 13, 2019

Preliminary Design Review	PDR	INAF	T0+11m	December 17, 2019
Detailed Design Review	DDR	INAF	T0+16m	May 7 ,2020
Final Review and Final Presentation	FR	ESTEC	T0+18m	July 7 ,2020

2.7.3 Bar chart

Figure 2-1 illustrates the Gantt chart driving the execution of the WBS. It shows the main project events (progress and milestone review meetings) and the proposed duration and dependencies of the tasks.



Figure 2-1: Gantt chart of the project, reflecting the WBS.

2.7.4 Deliverable items

We accept to deliver all required items as listed in Tab.1 of the Statement of Work. Table 2-4 reports the documents that XRS team will deliver to ESA for completion of the development program. Electronic files and paper copies will be delivered to ESA two weeks before the milestone events.

Table 2-4. Deliverable document list.

ID	Title	Milestone	WP Contributing (book captain in bold)			
			INAF	EIE	MLT	GPAP
D1	Requirements Specification Document	SRR	1110	1120	1230	
D2	Conceptual Design Report		1210	1220	1230	
D3	Trade-off Report		1210	1220	1230	
D4	Preliminary Design Document		2010	2020	2030	
TN1	Vacuum Chamber			2020		
				3020		
TN2	X-ray Source and Collimator System				2030	
					3030	
TN3	Raster Scan System (incl. x, y stage and			2020		

	metrology/vericalisation)	DDR		3020		
TN4	MA and SIM Mechanical Support and MA Thermal System				2030	
					3030	
TN5	X-ray Detector and (x, y, z) Stage		2010			5100
			3010			
TN6	Gravity Release Structure/Mechanism				2030	
					3030	
TN7	Metrology System (source/optics/detector)				2030	
					3030	
TN8	Ground Support Equipment (incl. MGSE, OGSE, ESGE)				2030	
					3030	
TN9	XRS Facility Infrastructure		2010	2020	2030	
			3010	3020	3030	
TN10	Interface Specifications		2010	2020	2030	
			3010	3020	3030	
TN11	Concept of Operation		2010	2020	2030	
			3010	3020	3030	
TN12	Technical Budgets		2010	2020	2030	
			3010	3020	3030	
TN13	Requirement Compliance Matrix		2010	2020	2030	
			3010	3020	3030	
TN14	Product Tree		2010	2020	2030	5100
			3010	3020	3030	
TN15	Critical Item List		2010	2020	2030	
			3010	3020	3030	
D5	Detailed Design Document	DDR	3010	3020	3030	
TN16	Development Plan		4010	4010	4030	5100
TN17	Schedule estimate for the XRS Facility development		4010	4010	4030	5100
TN18	Cost estimate for the XRS Facility development	Final Review	4010	4010	4030	5100
TN19	Schedule estimate for the MA QM/FM verification and calibration campaign		4010	4010	4030	5100
TN20	Cost estimate for the MA QM/FM verification and calibration campaign		4010	4010	4030	5100
TN21	XRS Facility User Manual		4010	4010	4030	
FR	Final Report		4010	4010	4030	
SR	Summary Report		4010	4010	4030	
CCD	Contract Closure Documentation	Contract Closure	5100			
TAT	Technology Achievement Template		5100			
WAT	Website Article Template		5100			

2.7.5 Non-conformances/limitations/additions regarding deliverable items

N/A

3 FINANCIAL PART

3.1 PRICE QUOTATION FOR THE CONTEMPLATED CONTRACT:

The total price for all the proposed activities amounts to **300,000 EUR**.

The type of price is Firm Fixed Price and is free from taxes and customs duties.

No licences of Intellectual Property Rights owned by any Third Party will be purchased for the execution of the contract and consequently have been included as cost for the project.

All the prices quoted in this document are in EURO.

The Geographical distribution of the project is totally Italian.

3.2 SUBCONTRACTING PLAN

Name	Country	WPs assigned	Place	Quote	%
INAF (PRIME)	IT	1110, 1210, 2010, 3010, 4010	Milano (MI) Italy	70000	23
Media Lario	IT	1130, 1230, 2030, 3030, 4030	B.Parini (LC) Italy	50000	17
GP Advanced Project	IT	5300	Brescia (BS) Italy	20000	7
EIE	IT	1120, 1220, 2020, 3020, 4020	Mestre (VE) Italy	160000	53

DETAILED PRICE BREAKDOWN

3.2.1 PSS costing forms:

See ANNEX 1

3.2.2 Milestone Payment Plan