



<b>Publication Year</b>	2021
<b>Acceptance in OA @INAF</b>	2022-03-17T16:02:15Z
<b>Title</b>	IXPE instrument integration, testing and verification
<b>Authors</b>	TOBIA, ANTONINO; TROIS, ALESSIO; DEL MONTE, Ettore; RUBINI, ALDA; FABIANI, Sergio; et al.
<b>DOI</b>	10.1117/12.2567002
<b>Handle</b>	<a href="http://hdl.handle.net/20.500.12386/31683">http://hdl.handle.net/20.500.12386/31683</a>
<b>Series</b>	PROCEEDINGS OF SPIE
<b>Number</b>	11444

# PROCEEDINGS OF SPIE

[SPIDigitalLibrary.org/conference-proceedings-of-spie](https://spiedigitallibrary.org/conference-proceedings-of-spie)

## IXPE instrument integration, testing and verification

Tobia, Antonino, Trois, Alessio, Del Monte, Ettore, Fabiani, Sergio, Soffitta, Paolo, et al.

Antonino Tobia, Alessio Trois, Ettore Del Monte, Sergio Fabiani, Paolo Soffitta, Fabio La Monaca, Alda Rubini, Alessandro Di Marco, Fabio Muleri, "IXPE instrument integration, testing and verification," Proc. SPIE 11444, Space Telescopes and Instrumentation 2020: Ultraviolet to Gamma Ray, 1144461 (6 January 2021); doi: 10.1117/12.2567002

**SPIE.**

Event: SPIE Astronomical Telescopes + Instrumentation, 2020, Online Only

# IXPE instrument integration, testing and verification

Antonino Tobia<sup>\*a</sup>, Alessio Trois<sup>c</sup>, Ettore Del Monte<sup>a</sup>, Alda Rubini<sup>a</sup>, Sergio Fabiani<sup>a</sup>, Fabrizio Amici<sup>a</sup>, Primo Attina<sup>b</sup>, Daniele Brienza<sup>a</sup>, Enrico Costa<sup>a</sup>, Sergio Di Cosimo<sup>a</sup>, Alessandro Di Marco<sup>a</sup>, Giuseppe Di Persio<sup>a</sup>, Yuri Evangelista<sup>a</sup>, Riccardo Ferrazzoli<sup>a</sup>, Fabio La Monaca<sup>a</sup>, Carlo Lefevre<sup>a</sup>, Alfredo Morbidini<sup>a</sup>, Fabio Muleri<sup>a</sup>, Raffaele Piazzolla<sup>a</sup>, John Rankina, Ajay Ratheesh<sup>a</sup>, Francesco Santoli<sup>a</sup>, Emanuele Scalise<sup>a</sup>, Fei Xie<sup>a</sup>, Luca Cavalli<sup>d</sup>, Andrea Sciortino<sup>d</sup>, Marco Vimercali<sup>d</sup>, Francesco Zanetti<sup>d</sup>, and on the behalf of IXPE Team.

<sup>a</sup>INAF-IAPS Via del Fosso del Cavaliere 100, I-00133, Roma, Italy <sup>b</sup>INAF-OATO, Strada Osservatorio 20, I-10025 Pino Torinese (TO), Italy <sup>c</sup>INAF-OAC, Via della Scienza 5, I-09047 Selargius (CA), Italy <sup>d</sup>OHB Italia SpA, Via Gallarate, 150, I-20151 Milano (MI), Italy.

## ABSTRACT

The Imaging X-ray Polarimetry Explorer (IXPE) is a scientific observatory with the purpose of expand observation space adding polarization property to the X-ray source's currently measured characteristics. The mission selected in the context of NASA Small Explorer (SMEX) is a collaboration between NASA and ASI that will provide to observatory the instrumentation of focal plane. IXPE instrument is composed by three photoelectric polarimeters based on the Gas Pixel Detector (GPD) design, integrated by INFN inside the detector unit (DU) that comprises of the electrical interfaces required to control and communicate with the GPD. The three DUs are interfaced with spacecraft through a detector service unit (DSU) that collect scientific and ancillary data and provides a basically data handling and interfaces to manage the three DUs. AIV has been planned to combine calibration of DUs and Instrument integration and verification activities. Due the tight schedule and the scientific and functional requirements to be verified, in IAPS/INAF have been assembled two equipment's that work in parallel. The flight model of each DU after the environmental tests campaign was calibrated on-ground using the Instrument Calibration Equipment (ICE) and subsequently integrated in the instrument in the AIV-T process on a AIV and Calibration Equipment (ACE), both the facilities managed by Electrical Ground Support Equipment (EGSE) that emulate the spacecraft interfaces of power supply, functional and thermal control and scientific data collection. AIV activities test functionalities and nominal/off-nominal orbits activities of IXPE instrument each time a calibrated DU is connected to DSU flight model completing step by step the full instrument. Here we describe the details of instrumentation and procedures adopted to make possible the full integration and test activities compatibly with calibration of IXPE Instrument.

**Keywords:** Imaging X-ray Polarimetry Explorer, AIV-T, Electrical Ground Support Equipment

## 1. INTRODUCTION

IXPE<sup>[1]</sup> is a scientific space observatory with the purpose to expand observation space domain adding polarization property to the X-ray source's characteristics. The mission selected in the context of NASA Small Explorer (SMEX) is a collaboration between NASA and ASI that will provide to observatory the instrumentation of focal plane. SMEX missions typically had three years between mission definition and launch. This short schedule has posed significant challenges with respect the focal plane calibration and integration activities. The AIV activities has been the last before the shipment of the instrument to the Ball Aerospace, in charge to produce spacecraft and integrate the payload on it. AIV has been subject to all the schedule modifications due to manufacturing, environmental tests and scientific calibration of the flight units compounding the IXPE instrument. X-Ray polarimetry, moreover, requires the capability of the Instrument to collect and store a large amount of data, all the collected tracks produced by incoming X-Ray photons must be downloaded to ground to proceed with the scientific analysis.

---

\* Further author information: Send correspondence to antonino.tobia@inaf.it; phone +39 06 45488032.

Test campaign conducted at the end of the IXPE instrument integration is the only moment in which the flight instrument is fully integrated and can be verified its capability to handle X-Ray celestial high-rate emission sources without data loss or distortion. End to End tests activities need to last at least two weeks, in this way has been verified that the instrument can operate collecting data without human intervention for at less two weeks.

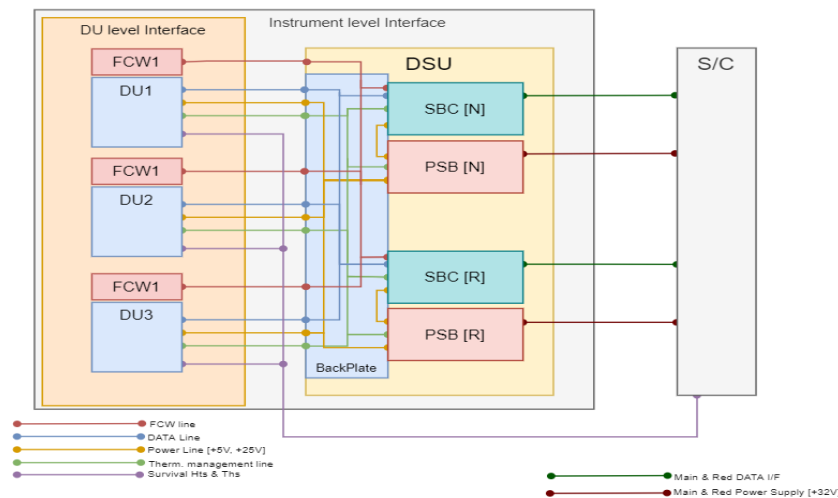

Figure 1. Scheme of all the interfaces of IXPE instrument.

## 2. IXPE INSTRUMENT DESCRIPTION

IXPE instrument is based on Gas Pixel Detector (GPD<sup>[2], [3]</sup>), GPD is integrated in Detector Unit (DU), that comprises back end electronics with two boards in charge to provide high and low voltages to GPD and a DAQ board in charge to configure and collect data from GPD. DU also includes the filter and calibration wheel (FCW<sup>[4]</sup>) that holds flight calibration sources and filters and on top of external window a cylindrical collimator to improve photons collection from celestial source. Instrument is composed by three DUs connected to a Detector service unit (DSU) that can control, configure, and download data from the DUs. DSU includes two boards for section, the single board computer (SBC) that hosts the on-board computer and the power service board (PSB) that supply the units compounding the payload. IXPE instrument presents two levels of integration: DU level with interfaces toward the DSU and Instrument level with interfaces toward the S/C (see Figure 1). DUs has been designed, integrated, and tested by INFN-Pisa, after environmental tests the single DU has been delivered to IAPS-Roma to proceed with scientific calibration and Instrument integration. We have produced four flight models for the DUs, three more one spare, and two engineering models, used to dry run all the operations that would have involved flight models. DSU has been designed, integrated, and tested by OHB-I, primer contractor that produced electrical parts (DU, DSU, harness and EGSE) of IXPE Instrument. DSU has been delivered to IAPS-Rome after environmental tests. Two models for the DSU have been produced and delivered, electrical models and flight models. The electrical model of DSU is functionally identical to the flight model.

## 3. INSTRUMENT REQUIREMENTS

IXPE Observatory requirements descend from combination of engineering and scientific needs. Spacecraft that hosts the observatory is provided by Ball-Aerospace, it has interface data rate requirement fixed by asynchronous RS-422 link and cable length between DSU and spacecraft at 2 Mbps, starting from this the payload has been designed to handle the brightest source that observatory can acquire reducing scientific data rate to be compatible with interface limit. The brightest source that observatory can acquire is a source with two-time Crab Nebula emission rate that technically corresponds to a source with emission rate of 900 counts per seconds with energy in range 1.0 – 12 keV over the three DUs. Single DU for this kind of source must produce an interface to DSU load at maximum of 0.75 Mbps. IXPE Instrument uses in DU a MIDI compression algorithm to reduce the data generated by GPD in compliance with interface

toward the DSU. DSU can improve the compression introducing a lossless filter to the scientific data. In particular, the DSU is able to remove orphan pixels that do not contribute to the scientific information. Orphan removal algorithm can remove pixels in the photons' tracks that have not collected charges in the pixels nearby. Using orphan removal, the data produced by the three DUs is reduced by DSU of about 20% for the source indicated in the requirement. The compliance with the s/c interface is verified considering also the ancillary telemetry produced by instrument. IXPE Observatory presents one interface toward the s/c so the 2 Mbps of requirement refers to all the telemetry produced by payload.

#### 4. IXPE INSTRUMENT INTEGRATION AND TEST ACTIVITIES

Small explorers are a category of satellite with a short term between proposal and launch, IXPE Observatory has allocated for the payload 18 months during which the instrument has been produced, verified, integrated, and calibrated. Due to the complexity of instrument and operations associated during integration and test, integration and verification activities have been divided in three different moments that meet the dates of units' production.

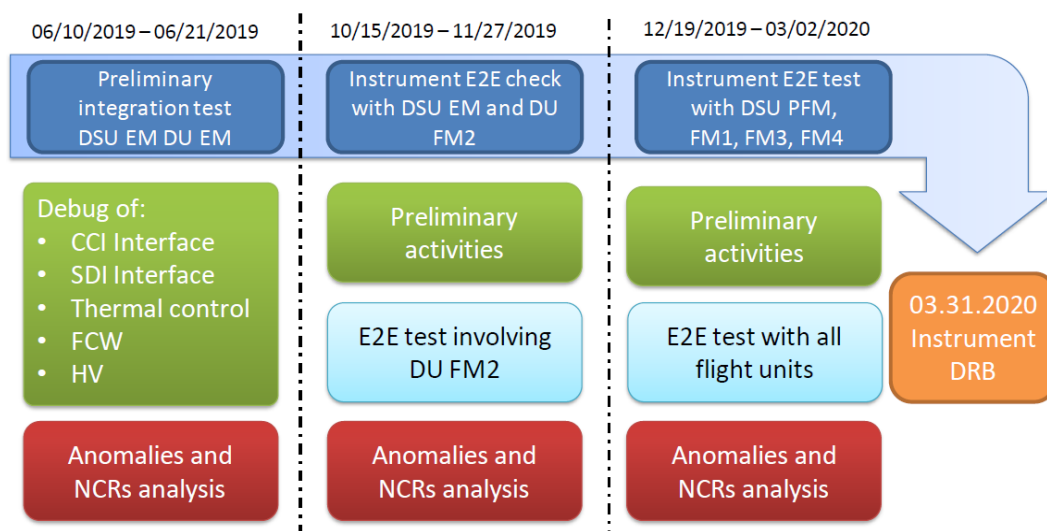

Figure 2. IXPE Instrument integration and test activity flow

In Figure 2 is reported the workflow defined to minimize the risk of issues when flight models have been produced and integrated in the IXPE instrument. Integration and verification of the flight model instrument required two months with one month of continuous in flight like activity without human intervention. Thanks to the preliminary integration test using DU EM and DSU EM we have avoided to meet issues during flight units' integration speeding up the activities and leaving more time for Instrument performance tests activities. Second phase involves DSU EM and three flight models of DU more one engineering model. Functionally the instrument is complete, we performed all the functional tests ensuring the correct behavior of DSU in instrument configuration (DSU has been tested using DU simulators during its environmental test campaign). This phase was fundamental to go ahead in DSU flight model design and manufacturing avoiding issues coming from the interfaces toward DUs. During last phase we integrated the full flight instrument. Delivered flight model of DSU has been on top debugged in its interfaces toward the DUs using engineering model of DU so to ensure that not damages will be propagated to the flight models of DUs (in this phase all DUs are calibrated and full tested). Next, incrementally, we added one by one the flight models of DUs that have completed the calibration campaign using the calibration facility (ICE<sup>(5)</sup>) located in the same clean room. At the end of the integration of the IXPE Instrument, it has been tested to evaluate the performances of instrument with flight like configurations and bright celestial source observation.

#### 4.1 Facilities involved in AIV-T activities

IXPE Instrument required a dedicated mechanical facility to make possible the integration, verification, and test. The mechanical facility: AIV-T and Calibration Equipment (ACE) comprises all the mechanical parts needed to fix in the right and safe position the Units. ACE mechanically supports the X-Ray tubes used as sources with high rate for each mounted detector unit and all the apparatus required as power supply and “He Line” necessary to reduce X-ray absorption by air (see. Figure 4). “He-line” is fundamental to improve the rate of photons that reaches the detector allowing to test behaves of Instrument with high rate of incoming photons.

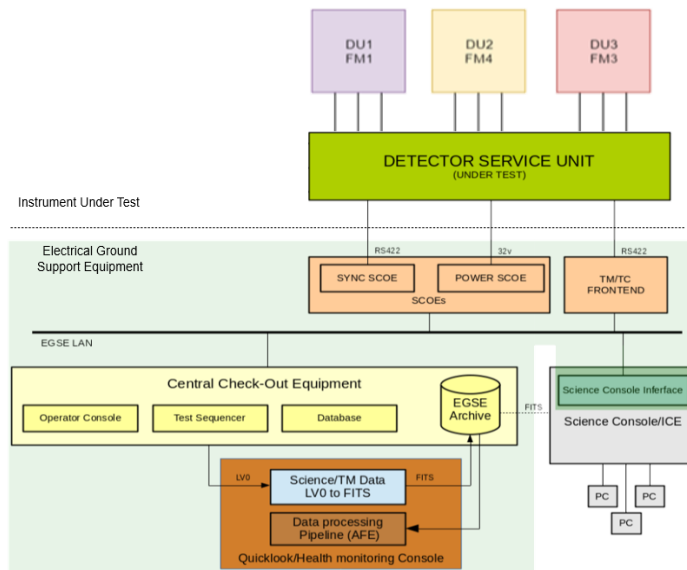

Figure 3. IXPE Instrument configuration and EGSE logical breakdown

The Electrical ground support equipment (EGSE) produced by OHB-I has been used to control and supply the instrument. It is used to send telecommands in the format accepted by payload and collect telemetry produced by payload formatting data. Telemetry produced is collected and stored internally ready to be analyzed so to verify in real-time correctness of operations. Figure 3 shows the full instrument setup block diagram and the EGSE logical breakdown.

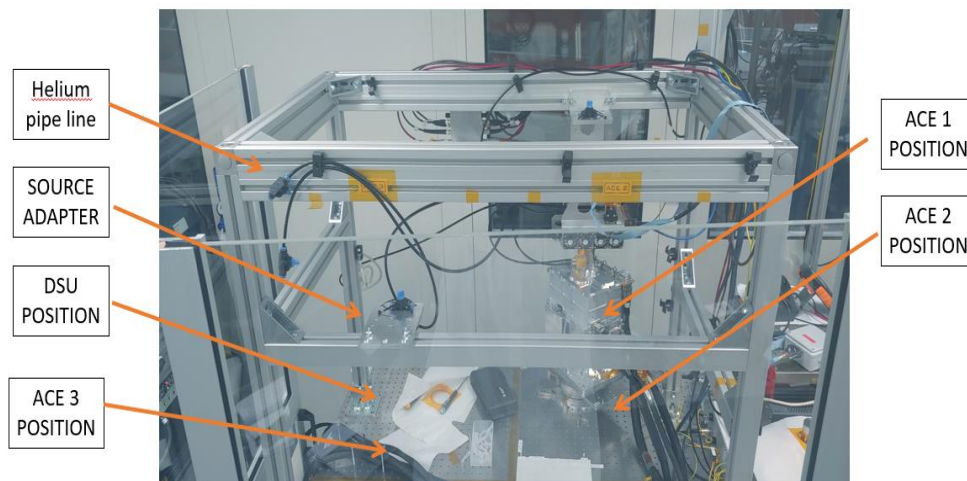

Figure 4. AIV-T and Calibration Equipment facility description.

## 4.2 Integration and test activities description

With the IXPE instrument integrated in all its parts (see Figure 5), we had verified performances simulating on flight high-rate X-Ray source observation with on board flight like configuration. Instrument was periodically powered up and configured in all its parts (Thermal control and FDIR) to simulate in orbit operations (Observation, South Atlantic Anomaly crossing, Calibration). During simulated orbits instrument has performed an observation of 80 minutes of external X-Ray source, interleaved by a SAA crossing of 10 in which GPD High Voltages were decreased to inhibit GEM (gas electron multiplier) multiplication, and a 10-minutes calibration with one of the FCW sources. From collected telemetry we calculated the Instrument interfaces load that is the most relevant instrument requirement to ensuring correct data collection and on ground download.

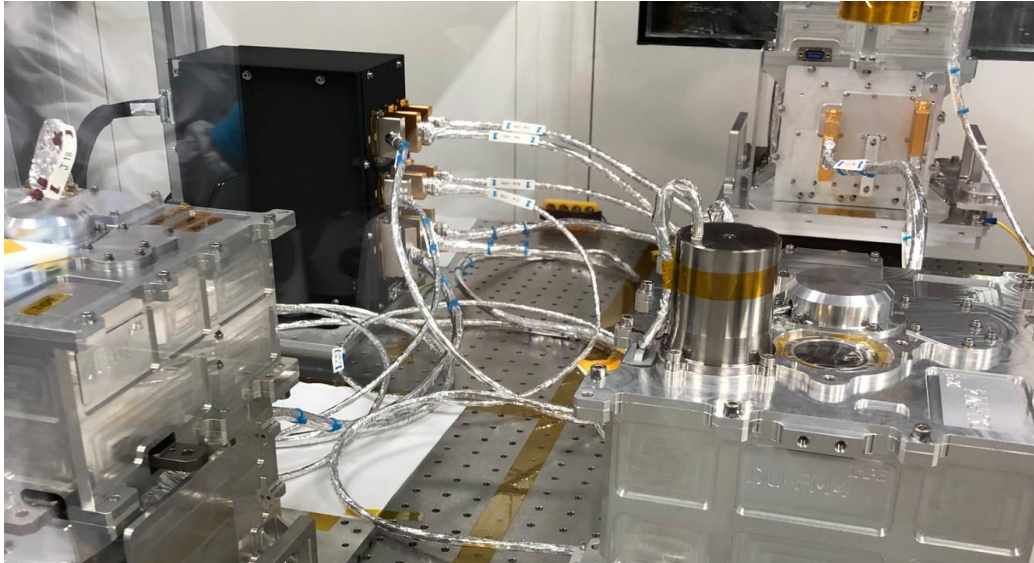

Figure 5. Picture of Ixpe instrument fully integrated on ACE.

Sources and models used during this test are reported in Table 1, two DUs out of three have been illuminated with Crab Like sources (X-Ray tubes with external power supply to produce high rate about 3KeV photons), one (FM1) has been illuminated with a radionuclide source ( $^{55}\text{Fe}$ ). Apply different sources has been useful to test the capability of detector to handle sources with energies that produces tracks with different length (in this case double respect the other two sources), reducing data produced changing detector threshold configuration.

Table 1. Source configuration & DUs configuration

UNIT	DU1 FM1	DU2 FM4	DU3 FM3
Source Configuration	$^{55}\text{Fe}$ Radionuclide	Ag Tube	Rd Tube
Energy	5.9 keV	3 keV	2.7 keV
Rate recorded by Instrument	310 c/sec	290 c/sec	300 c/sec



## 5. RESULTS

During performance test we verified the compliance of IXPE instrument with Instrument requirements after the full integration. The activity lasted two weeks due the calibration schedule, we reached for both the sections of Instrument (nominal and redundant) about 160 orbital cycles collecting about 800 million events.

In Figure 6 are reported results for nominal side of instrument: on left is shown the histogram of source rate recorded by the different DUs and the total rate collected by the instrument, on right is reported the load on the interface toward the s/c, the mean value of rate does not reach the 900 c/sec due a “He line” problem, that has been resolved before to start redundant side performance test.

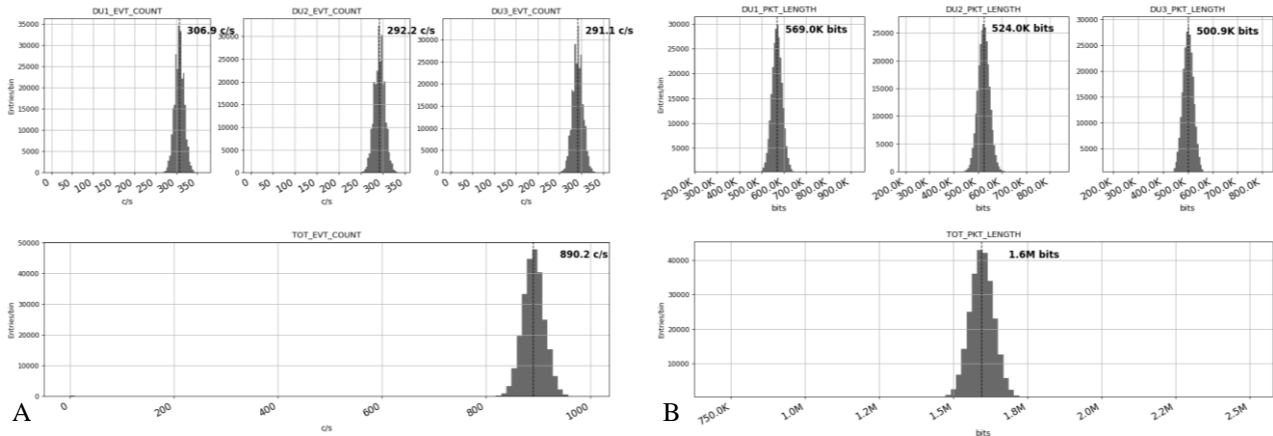

Figure 6. Ratemeters results DSU Nominal side (A) Photons Rate recorded by Instrument, (B) Instrument toward spacecraft interface load.

In Figure 7 are reported results of performance test for redundant side of instrument: on left is reported the histogram of source rate recorded by the different DUs and the total rate collected by the instrument, on right is reported the load on the interface toward the s/c.

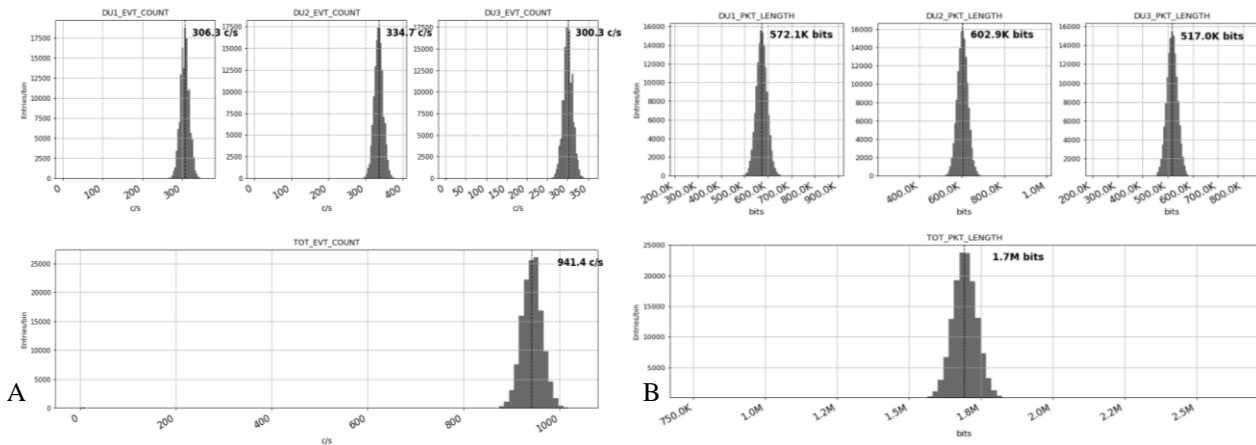

Figure 7. Ratemeters results DSU Redundant side (A) Photons Rate recorded by Instrument, (B) Instrument toward spacecraft interface load.

From Figure 7 and 8 is evident that the scientific telemetry load produced by the instrument when illuminated with a two-time Crab-nebula like source is compliant with the s/c interface requirement of 2Mbps. Moreover, as proof of fact that the instrument can transmit to s/c all the collected tracks, no telemetry of buffer saturation/de-saturation has been produced during the orbits by the instrument.



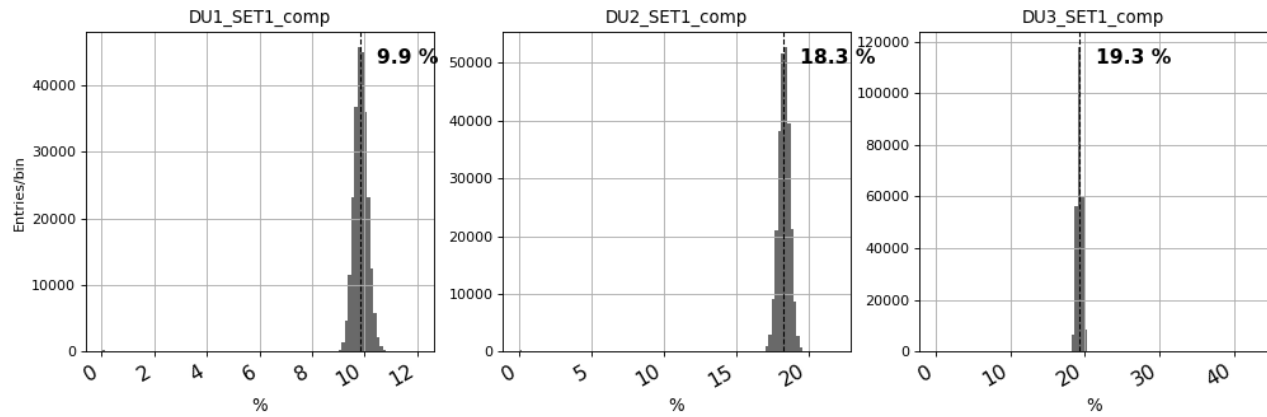

Figure 8. Compression applied by DSU to packets provided by DUs

In Figure 8 is reported the effective data packets dimension reduction introduced by DSU applying orphan removal algorithm, as expected the algorithm is more effective for short tracks (low energies) reducing tracks data load of about 18% and making the Instrument compliant with the requirements.

Scientific data produced during orbits has been crudely analyzed to verify that DSU data handling (orphan removal algorithm) do not affect compliance of detectors to requirements in terms of dead time and energy resolution in both configurations (Nominal and Redundant). Moreover, detector dead time is used to go back to effective X-Ray source emission rate. Calculated photons emission rate for the three sources is of about 1400 c/secs with a dead time of 1 msec for each detector unit.

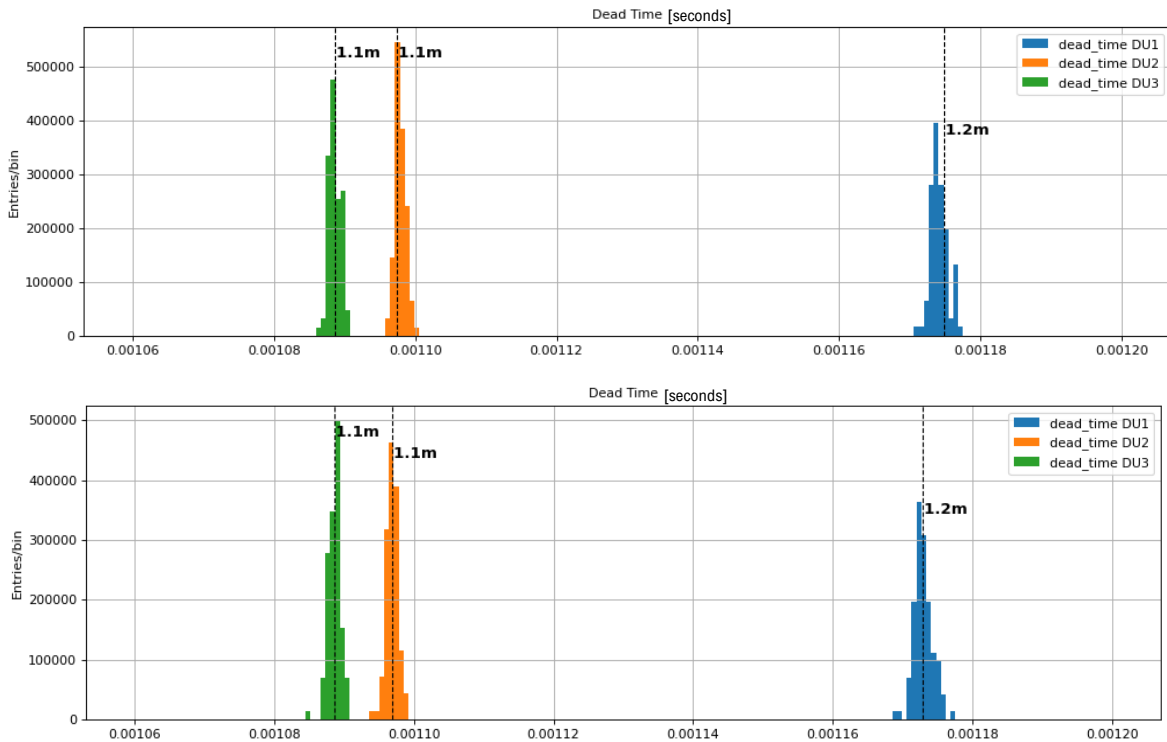

Figure 9. Plots of dead time trend histogram of each DU calculated-on photons acquisition performed during simulated orbits: nominal and redundant side are on top and bottom panels, respectively.

Figure 9 reports histogram of dead time value calculated from scientific data collected during simulated orbits, all photons collected by the available detector area are considered in the analysis. The performances of detectors are the same using both the sides of DSU: nominal and redundant.

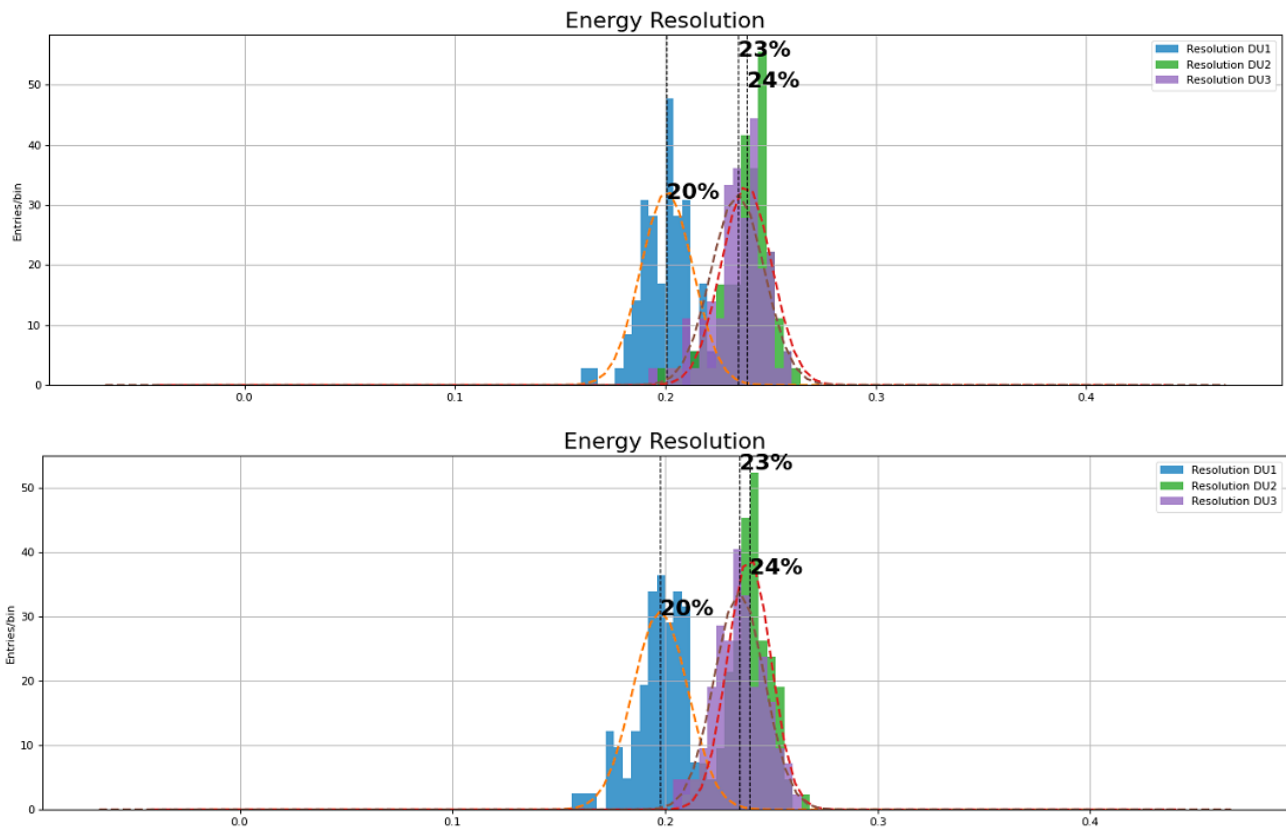

Figure 10. Plots of calculated and not correct energy resolution trend histogram of each DU calculated-on photons acquisition performed during simulated orbits: nominal and redundant side are on top and bottom panels, respectively.

Figure 10 reports energy resolution calculated from scientific data collected during simulated orbits. Spectrum is filled only with the events reconstructed in a spot of 500  $\mu\text{m}$  radius, extracted from flat field measurements. The requirement for energy resolution is 25% at 5.9keV (DU1 results can be used to verify compliance with requirement). Many factors contribute to the energy resolution: GEM charging, GEM gain disuniformity and photons energy, we report raw value without post calibration correction. Reported results show compliance of instrument to requirements and evidence that neither section affect scientific performances of instrument.

## 6. CONCLUSIONS

Integration test and verification activities on flight models of IXPE Instrument end as proof of compliance with defined requirements. During performance test activity, necessary to verify that the integration of Instrument was successful, instrument completes a total (using nominal and redundant side) of 160 orbital cycles and collects about 800 million events at maximum rate of about 900 c/sec without relevant anomalies and human intervention, changing as required by orbit, all the different operative modes necessary to configure instrument and acquire photons tracks. Results show that the telemetry load toward the s/c is lower that 2Mbps for X-Ray energy and photons rate required for both the Instrument sections, as we expect, otherwise Instrument would produce dedicated telemetry about the buffer status and scientific data would be lost. From a more deep collected scientific data analysis has been verified that DSU data handling do not introduce systematics on collected photon's tracks or on photon's timing profile.

## ACKNOWLEDGEMENT

The Italian contribution to the IXPE mission is supported by the Italian Space Agency (ASI) through the contract ASI-OHBI-2017-12-I.0, the agreements ASI-INAF-2017-12-H0 and ASI-INFN-2017.13-H0, and its Space Science Data Center (SSDC), and by the Istituto Nazionale di Astrofisica (INAF) and the Istituto Nazionale di Fisica Nucleare (INFN) in Italy.

## REFERENCES

- [1] O'Dell, S. o. b. o. t. I. C., "The Imaging X-ray Polarimetry Explorer (IXPE): Overview II," Proc. SPIE 11118, (2019).
- [2] Costa, E., Soffitta, P., Bellazzini, R., Brez, A., Lumb, N., and Spandre, G., "An efficient photoelectric X-ray polarimeter for the study of black holes and neutron stars," Nature 411, 662 (2001).
- [3] Bellazzini, R., Spandre, G., Minuti, M., Baldini, L., Brez, A., Latronico, L., Omodei, N., Razzano, M., Massai, M. M., Pesce-Rollins, M., Sgrò, C., Costa, E., Soffitta, P., Sipila, H., and Lempinen, E., "A sealed Gas Pixel Detector for X-ray astronomy," Nuclear Instruments and Methods in Physics Research A 579, 853 (2007).
- [4] Ferrazzoli, R., Muleri, F., Lefevre, C., et al, "In-flight calibration system of Imaging X-ray Polarimetry Explorer," JATIS 20117R (2020)
- [5] Muleri, F., Lefevre, C., Piazzolla, R., Morbidini, A., Amici, F., et al, "Calibration of the IXPE instrument," in Proc. SPIE, 10699 (2019).