



Publication Year	2018
Acceptance in OA @INAF	2022-03-01T14:41:09Z
Title	MAORY requirements flow down and technical budgets
Authors	CORTECCHIA, Fausto; RIVA, Marco; BUSONI, LORENZO; ARCIDIACONO, CARMELO; Patti, Mauro; et al.
DOI	10.1117/12.2312081
Handle	http://hdl.handle.net/20.500.12386/31513
Series	PROCEEDINGS OF SPIE
Number	10703

PROCEEDINGS OF SPIE

[SPIDigitalLibrary.org/conference-proceedings-of-spie](https://spiedigitallibrary.org/conference-proceedings-of-spie)

MAORY requirements flow down and technical budgets

Cortecchia, F., Riva, M., Busoni, L., Arcidiacono, C., Patti, M., et al.

F. Cortecchia, M. Riva, L. Busoni, C. Arcidiacono, M. Patti, L. Schreiber, M. Lombini, E. Stadler, E. Diolaiti, P. Ciliegi, P. Feautrier, S. Esposito, R. Ragazzoni, "MAORY requirements flow down and technical budgets," Proc. SPIE 10703, Adaptive Optics Systems VI, 107034J (11 July 2018); doi: 10.1117/12.2312081

SPIE.

Event: SPIE Astronomical Telescopes + Instrumentation, 2018, Austin, Texas, United States

MAORY requirements flow down and technical budgets

F. Cortecchia*^a, M. Riva^b, L. Busoni^c, C. Arcidiacono^a, M. Patti^a, L. Schreiber^a, M. Lombini^a,
E. Stadler^d, E. Diolaiti^a, P. Ciliegi^a, F. Feautrier^d, S. Esposito^c, R. Ragazzoni^c

^aINAF - Osservatorio Astronomico di Bologna, Via Gobetti 93/3, 40129 Bologna (Italy);

^bINAF - Osservatorio Astronomico di Brera, Via E. Bianchi 46, 23807 Merate (Italy);

^cINAF - Osservatorio Astrofisico di Arcetri, Largo Enrico Fermi 5, 50125 Firenze (Italy);

^dInstitut de Planétologie et d'Astrophysique de Grenoble, 414, Rue de la Piscine,
Domaine Universitaire, 38400 St-Martin d'Hères (France);

^eINAF - Osservatorio Astronomico di Padova, Vicolo Osservatorio 5, 35122 Padova (Italy).

*fausto.cortecchia@inaf.it; phone 0039 051 6357 317; <http://www.oabo.inaf.it>

ABSTRACT

MAORY is the ELT-MCAO system providing first-light wide-field correction for the near infrared imager and spectrograph MICADO. This paper provides an overview of the systems engineering processes and tools implemented to MAORY project during preliminary design phase and it illustrates, with some practical examples, the role of MAORY technical budgets to derive requirements on subsystems. One of the critical activities in systems engineering is the requirements managing. In line with this, the MAORY team devotes a significant effort to this activity, which follows a well-established process. This involves the MAORY requirements break-down to subsystems level and from here down to subsystems procurements specifications. This paper also presents an overview of the MAORY Technical Budgets. One task of the System Engineering is to manage the technical budgets at system level combining the contributors at subsystems level to meet the overall requirements.

Keywords: ELT, Multi-Conjugate Adaptive Optics, Requirements, Flown-down, Traceability, Verification, Technical Budgets, Compliance

1. INTRODUCTION

MAORY subsystems are designed and built by different institutes at different timescale. The systems engineering decomposes the MAORY system in several subsystems that have to match each other in order to fulfill the MAORY level requirements. Such as decomposition follows mainly technical, functional and programmatic criteria. Specifying MAORY subsystems, system level interfaces (i.e. ELT vs MAORY vs MICADO) and subsystem level interfaces (i.e., between MAORY subsystems), and keeping all the requirements under control is not an easy task. In real-life work in the Systems Engineering activities were also involved the users of the subsystems documents to meet their needs.

The MAORY system engineering team has implemented a requirements management process that supports the specification, identification and traceability of the requirements; a significant effort is devoted to this activity. We aim to derive in an optimal manner the requirements from MAORY system level down to subsystems procurement specifications (i.e. linking the subsystem requirements).

The requirements identification and linking are crucial for configuration control since facilitates the managing of changes and the analysis on their impact may have at different levels of the system. Moreover, the requirements have usually attributes that do not end in the requirements specification documents; this implies that it is necessary to keep track of these significant information, such as requirement rationale, verification method, comments from MAORY team member, decisions on interested value and use for the project.

The implementation of these activities requires an effort from the authors, to organize information and to communicate it to whole MAORY team members. Without an appropriate tool and method, the information can be lost and become inconsistent. The requirements management process is assisted by Cameo Systems Modeler™, which keeps record of the linking information, the rationale behind the requirements and the verification information associated to every

requirement. In this way, we attempt to mitigate these difficulties and to get a transparent working process. In the following the Cameo Systems Modeler™ in the following referred to as CAMEO.

This paper describes the requirements management process, which is illustrated with some practical examples. The emphasis is made on the flowing-down of requirements. To help in understanding this process, the MAORY documentation relationship is presented. A fundamental role in requirements managing of MAORY is done by mean of technical budgets, which are maintained at system level. To understand their role, we show a summary of their use on one case.

1. MAORY DOCUMENTATION OVERVIEW

MAORY Systems Engineering (SE) is responsible for overseeing the overall design of the MAORY instrument up to commissioning. SE manages and maintains part of MAORY document (See Figure 1) to identify all documents (requirements, plans, etc.) needed by the project. To simplify requirements and interfaces and to allow clear and complete allocation of functions, we decompose the MAORY system into subsystems, which are defined following the Top Level Product Breakdown (See Figure 2). An NxN matrix (See Figure 3) is used for the identification of interface documentation that is needed and is an essential part of the development of the major system ICDs. This is kept separate due to the sheer volume of documents that it defines.

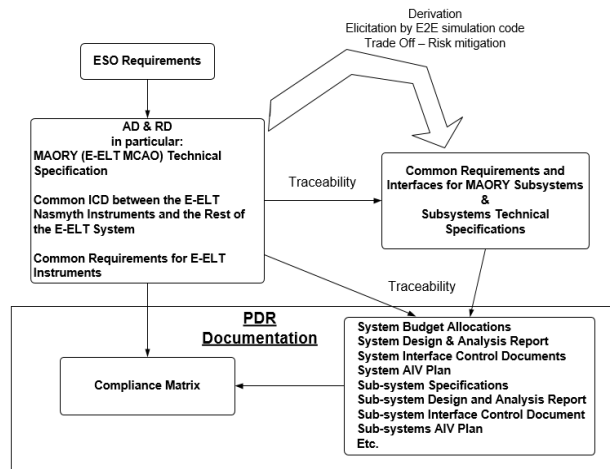

Figure 1. MAORY Documentation up to PDR.

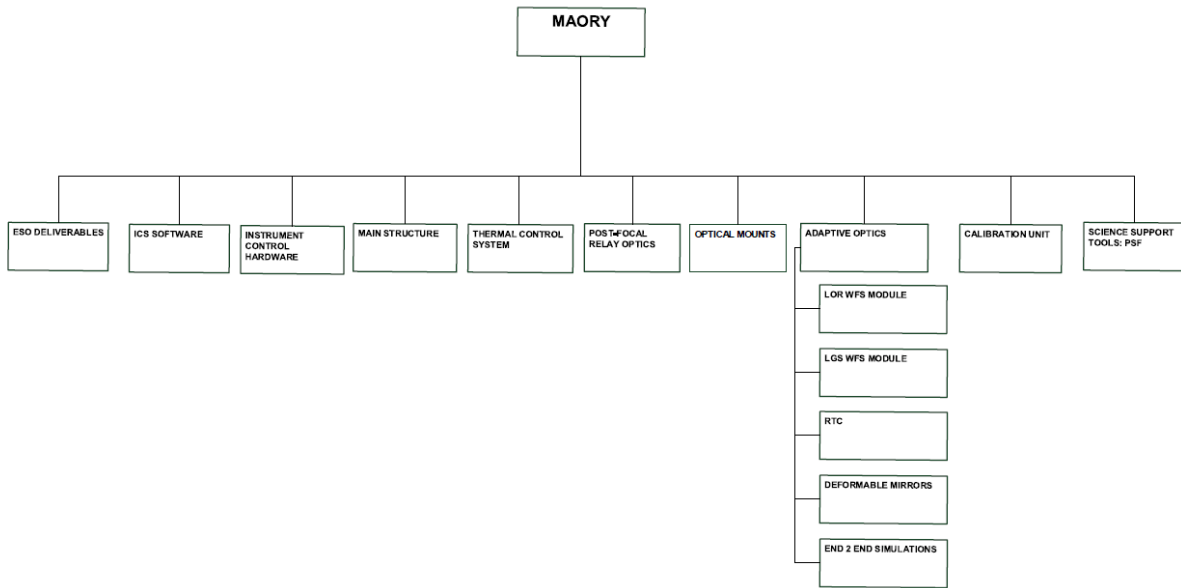

Figure 2. MAORY Top Level Product Breakdown.

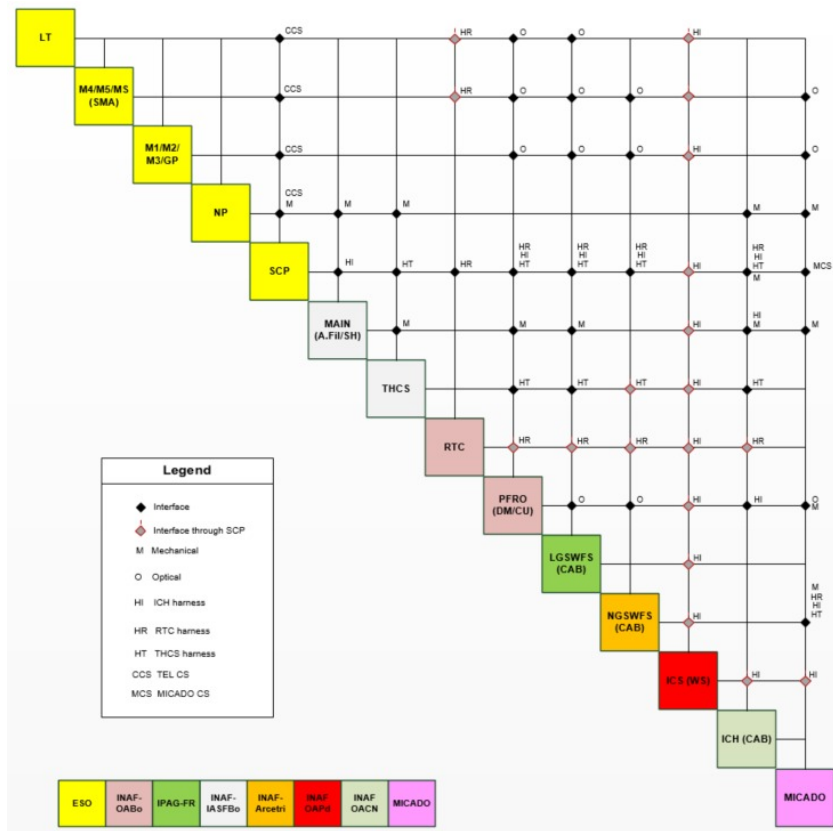

Figure 3. Interfaces definition: the MAORY NxN matrix.

2. TOOLS

MAORY team has chosen a set of necessary software tools to aid in the systems engineering and development of the MAORY requirement flow-down; these tools include Microsoft Office suite and CAMEO. These tools are used jointly for documenting and controlling the system architecture, design, analysis, requirements and sharing information with partners. Each of these tools is accessible through the internet MAORY web page and has been set up for as much ease of use as possible.

MAORY is making a transition from developing requirements in Word and Excel, and maintaining parallel version in CAMEO, to working directly in CAMEO and outputting document to PDF (via Word). The MAORY Requirement Structure and basic CAMEO schema are reported in the following sections. The planned solution for the management of requirements and interfaces is to maintain control of them in CAMEO and create traceability between requirements at various levels. We manage requirements and implement change proposal process directly in CAMEO.

We have taken a rigorous approach to defining our CAMEO procedures, document module views and attributes, filters and permissions, to enable us to work directly in CAMEO. The MAORY departments and partner technical teams do not have the permissions to directly modify requirement in CAMEO. This work is in its early stages but it is already showing significant advantages. Some of the key additions we are making in our CAMEO implementation include:

- Verification Cross-Reference Matrices, and Verification Activities are maintained CAMEO.
- Maintaining a list of Applicable and Reference Documents including standards and linking these with requirements. This allows visibility into where and how modifications to documents will affect the requirements.
- Adoption of a graphic derivation tree representation gives excellent visibility to the requirements and links between requirements across the MAORY project (figure 8).

3. REQUIREMENT FLOW-DOWN PROCESS

Our initial work with CAMEO was focused on developing and documenting the requirements from MAORY system level requirements down to subsystem requirements. Since then, as the systems engineering effort for the MAORY project has grown, we built up a comprehensive model using CAMEO (figure 4) to manage the flow down, traceability and validation of the requirements and use cases; identification, development and specification of system interfaces; development of functional and technical operations concepts; and the development of system verification planning activities.

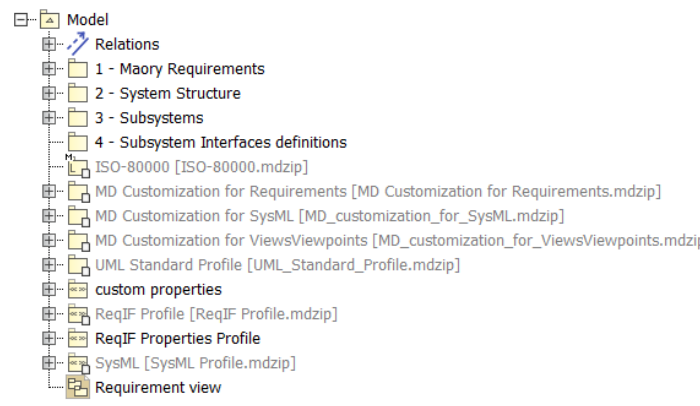

Figure 4. CAMEO Model structure.

In order to trace the requirement a proper structure of the model has been set up following the Object Oriented System Engineer Method (OOSEM). The model has been divided in sub-sequential packages. For each level (system, subsystem, etc.) there is a requirement package, a structure package and a subsystem package.

The capturing of the requirement started from the stakeholder requirement that included mainly three documents:

- MAORY -ELT MCAO- Technical Specification - Baseline 1.0;
- Common Requirements for ELT Instruments - Baseline 2.0;
- Common ICD between the ELT Nasmyth Instruments and the Rest of the ELT System - Baseline 3.0.

In addition, purely for the software WP there is the “ELT Instrument Control System Common Requirements - Baseline 2.0”.

From all this requirement it has been derived the first level set of requirement applicable to the system R-I00-XXX all these requirement have been directly traced, or in some cases derived, in order to obtain proper engineering values to be used as requirements.

If applicable, each requirement has been then flown down to the proper subsystems. Two different tracing properties have been used.

The simple *trace* is used when a requirement directly applies to the subsystems. An example of the full *tracing* flow is the stakeholder Access requirement R-MAO-111, which states “Access to the instrument across the Nasmyth platform shall be exclusively via the walkway area shown in AD6”. This requirement is directly *traced* down to R-I00-1.4.1 which states “Access to the instrument across the Nasmyth platform shall be exclusively via the walkway area as shown in CAD-130610”. This requirement is then directly *traced* only to (see figure 6) the Main Structure (MAO-IM0-1.4.1): “Access to the main structure across the Nasmyth platform shall be exclusively via the walkway area shown in CAD-130610” and to the Thermal Control System (MAO-IT0-1.4.1): “Access to the thermal control system across the Nasmyth platform shall be exclusively via the walkway area as shown in CAD-130610”.

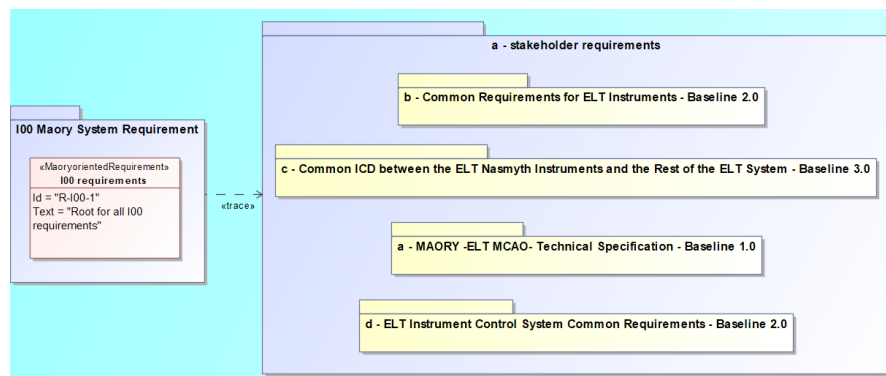

Figure 5. Derivation of the system first requirement level.

A second type of tracing has been used when a requirement applicable at system level (through a simple tracing link) is translated or budgeted to the subsystems level, as like for example the MAORY mass: in this case the derived link is used as shown in figure 7.

For each stakeholder requirement, tracing diagrams have been set up:

- the visual diagram can be used to monitor all derived requirements, as like the requirement derivation tree reported in figure 8;
- for a “better reading” a detailed view can be set, as example for the accessibility requirement shown in figure 9.

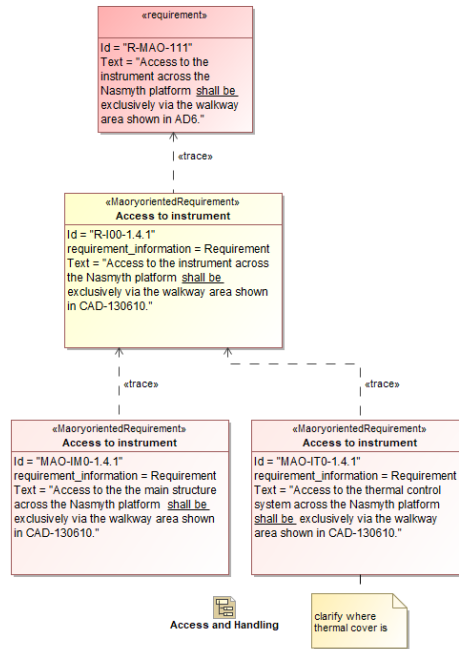

Figure 6. Example of direct tracing from stakeholder requirements to subsystem.

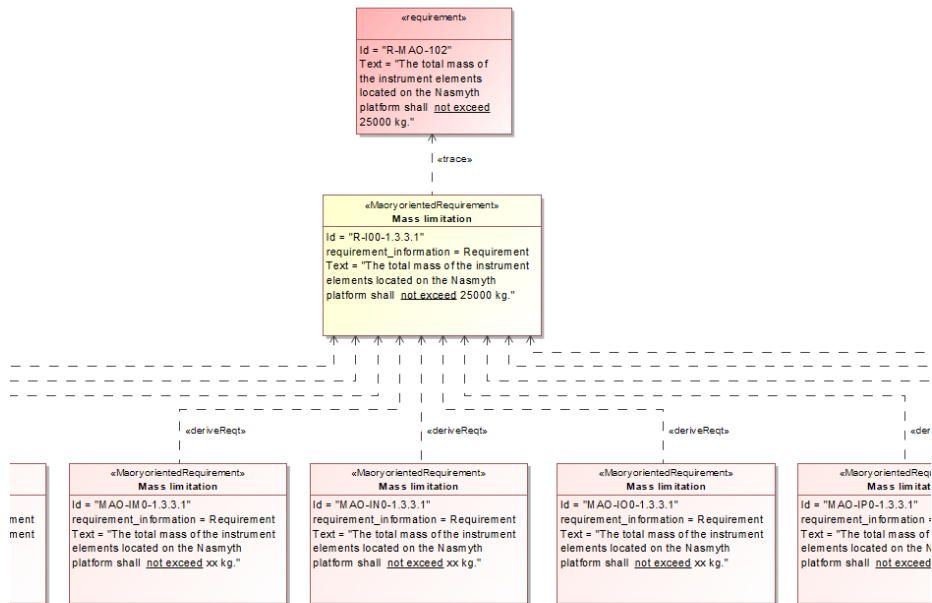

Figure 7. Extracted picture of a derived requirement through budget.

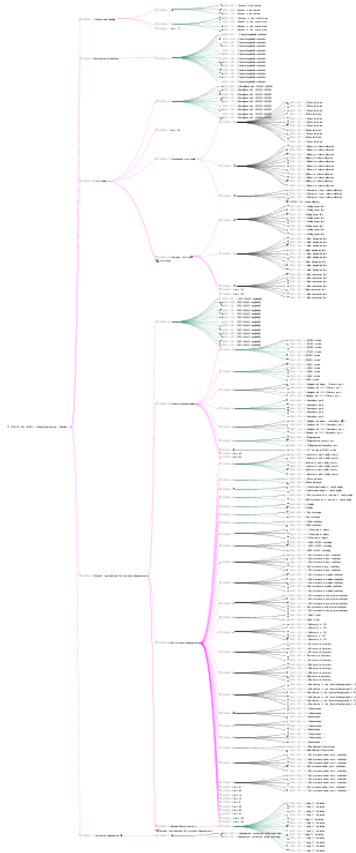

Figure 8. Full derivation tree (image not resolved).

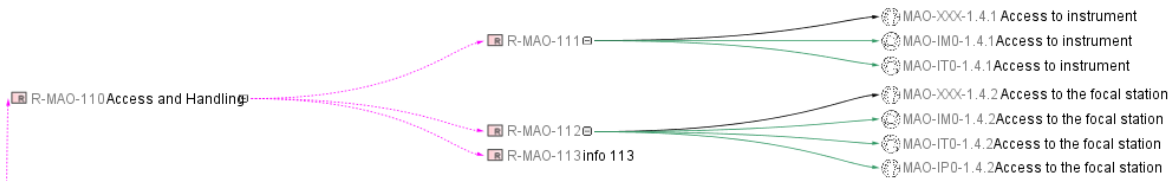

Figure 9. Details of the access and handling derivation tree (black derived ones, green traced ones).

4. ROLE OF THE TECHNICAL BUDGET

The role of technical budget is to detail and complete the flow of documents that drive the development from System level specifications to subsystems specification and back to the Compliance Matrix at system level. In general, these budgets allocate resources or performances based on MAORY level requirement. The budget allocations are traced to subsystems allocations. These relationships are recorder via link in CAMEO database (figure 7), allowing MAORY system engineering visibility to understand consequences of not meeting performance related requirement, and trade performance across subsystems.

To help in managing the process of flowing down the MAORY system requirements and to facilitate their allocation to its subsystems, a number of technical budgets have been prepared.

The key budgets tracked at the MAORY system level include:

- Mass
- Heat Dissipation, Electrical and Cooling Power Consumptions
- Reliability and Availability at system and subsystems levels
- Wavefront Error and Astrometric Budgets

To illustrate how technical budgets are used, the case of the average normal electrical power consumption is discussed. The MAORY Technical Specification states the following requirement:

The electrical power consumption of the instrument shall not exceed the following values:

- *Power from the Nasmyth SCP:*
 - *Average (over 24hours) normal power: 10.4 kW*
 - *Peak normal power: 25 kW*
 - *Average (over 24hours) safety power: 0.5 kW*
- *Power from the Computer Room:*
 - *Average (over 24hours) normal power: 25 kW*
 - *Peak normal power: 35.7 kW*

The assumptions used in elaborating the ANP (Average Normal electrical Power) consumption budget are:

- linear error combination;
- the average power consumption is computed over 24 hours;
 - 10 hours MAORY in observation or calibration mode during night-time;
 - 3 hours MAORY for scheduled calibration/maintenance mode during day-time;
 - MAORY system and sub-systems, warming-up and pumping are not considered in the average power supply, but they are considered for peak computation.

The technical budget prepared to help in allocating the average normal power consumption requirement is shown in Table 1. Each row corresponds to an item that is then allocated to a certain characteristic of a given subsystem and the corresponding requirement in the subsystem requirements specification is stated. Even if not explicitly stated in the table, the total budgeted value is below the requirement that means that a contingency can be allowed.

In order to establish the connection from the system level to the subsystem requirement specifications the budgets are also kept in the CAMEO. This allows defining a link from the system level requirement to the budgets items and from there to the subsystems requirements.

Table 1. Peak normal power consumption technical budget.

Identifier	Item	Average Power (W)
...
[TB-ANP- 3]	Average Normal power consumption of the LGSWFS	976
[TB-ANP- 4]	Average Normal power consumption of the NGSWFS	980
[TB-ANP- 5]	Average Normal power consumption of the DMs	1551
...		...
[TB-ANP- 10]	Total ANP budget	4783

5. VERIFICATION OF REQUIREMENTS

The CAMEO requirement package has been updated with custom properties in order to better fit with the user needs.

In particular, it has been modified the verification method property by having:

- Design;

- Analysis;
- Test;
- Inspection.

The verification method has been splinted for each project phases:

- PDR (preliminary design review) verification;
- FDR (final design review) verification;
- PAE (Preliminary Acceptance Europe) verification;
- PAC (preliminary acceptance Chile) verification.

It has also introduced a compliance property that allows:

- Compliances;
- Non-Compliances,
- Partially Compliances
- Non-Applicability.

Those properties will be used at different revision phases (PDR, FDR, PAE and PAC) to automatically generate the verification and compliance matrixes. A further linking property will allow to include in the matrixes a direct indication that will help the reader to immediately identify where the compliances to the requirement is shown and demonstrated (figure 10).

Different verification will be held at different levels. In detail, the tracing diagrams of each requirement (figure 6 and 7) will guide all the verification process (left side of the V-diagram). The confirmed verification of all the subsystem derived requirement will generate the verification of the system requirement and thus the stakeholder one. Vice-versa a non-compliance of one of the subsystem derived requirement will generate a non-compliance of the system parent requirement.

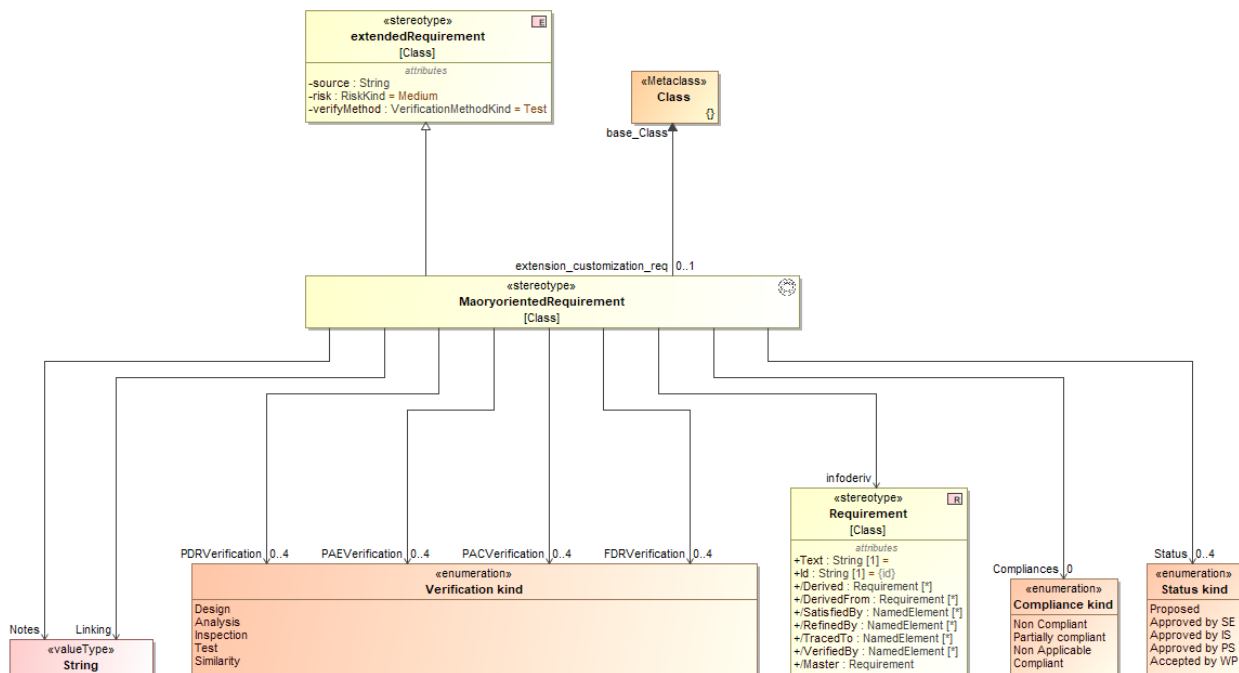

Figure 10. View diagram of the custom properties of the requirements.

6. CONCLUSIONS

Requirements management is one of the most critical processes in the scope of MAORY systems engineering. Properly specifying the several parts of the subsystems for procurement from industry and from consortia of institutes as well as properly following up compliance of the deliveries to the requirements is of primary for the success of the MAORY instrument. As part of this process, flowing-down requirements from top-level documents to subsystems specifications is crucial for the system to meet the user needs. This involves bottom-up consolidation of requirements that aims to specify feasible solutions.

MAORY is organized around a centralized but relatively small project office that directs and coordinates the work of a number of project teams and consultants. The MAORY project decided to introduce CAMEO to manage the requirement flown down and verification control. Over the last few months of usage, it has become clear that without the aid of this software tool it would have been very difficult to maintain the same level of control and consistency in MAORY. Understanding how one technical item interacts with another with the help of linking, helps us keep track of interdependencies and perform the trade studies that are needed to be certain that the impacts of changes are agreeable to all parties affected. Understanding how each subassembly interacts with the rest of the system and managing changes across the project helps avoid incompatibilities and ensures the project can achieve its system performance requirements.

It was also clear that a good communication tools is essential to manage this effort; in fact, there is always the risk that a team may not communicate the dependencies of its designs (and their changes from baseline) to the others.

Future work will focus communication improvement, completing the operations and verification modeling with the aim to converge at the end of the MAORY project in a set of clear recommendations and guidelines for future projects.