

Open Research Online

The Open University's repository of research publications and other research outputs

Some Problems of Co-operative Organisation

Other

How to cite:

Paton, Rob (1978). Some Problems of Co-operative Organisation. Monograph 3; Co-operatives Research Unit, The Open University.

For guidance on citations see [FAQs](#).

© [not recorded]



<https://creativecommons.org/licenses/by-nc-nd/4.0/>

Version: Version of Record

Link(s) to article on publisher's website:

<http://dx.doi.org/doi:10.21954/ou.ro.00015ba5>

Copyright and Moral Rights for the articles on this site are retained by the individual authors and/or other copyright owners. For more information on Open Research Online's [data policy](#) on reuse of materials please consult the policies page.

oro.open.ac.uk

SOME PROBLEMS OF CO-OPERATIVE ORGANISATION

by
Rob
Paton



Co-operatives Research
Monograph No.3



Co-operatives Research Unit
The Open University

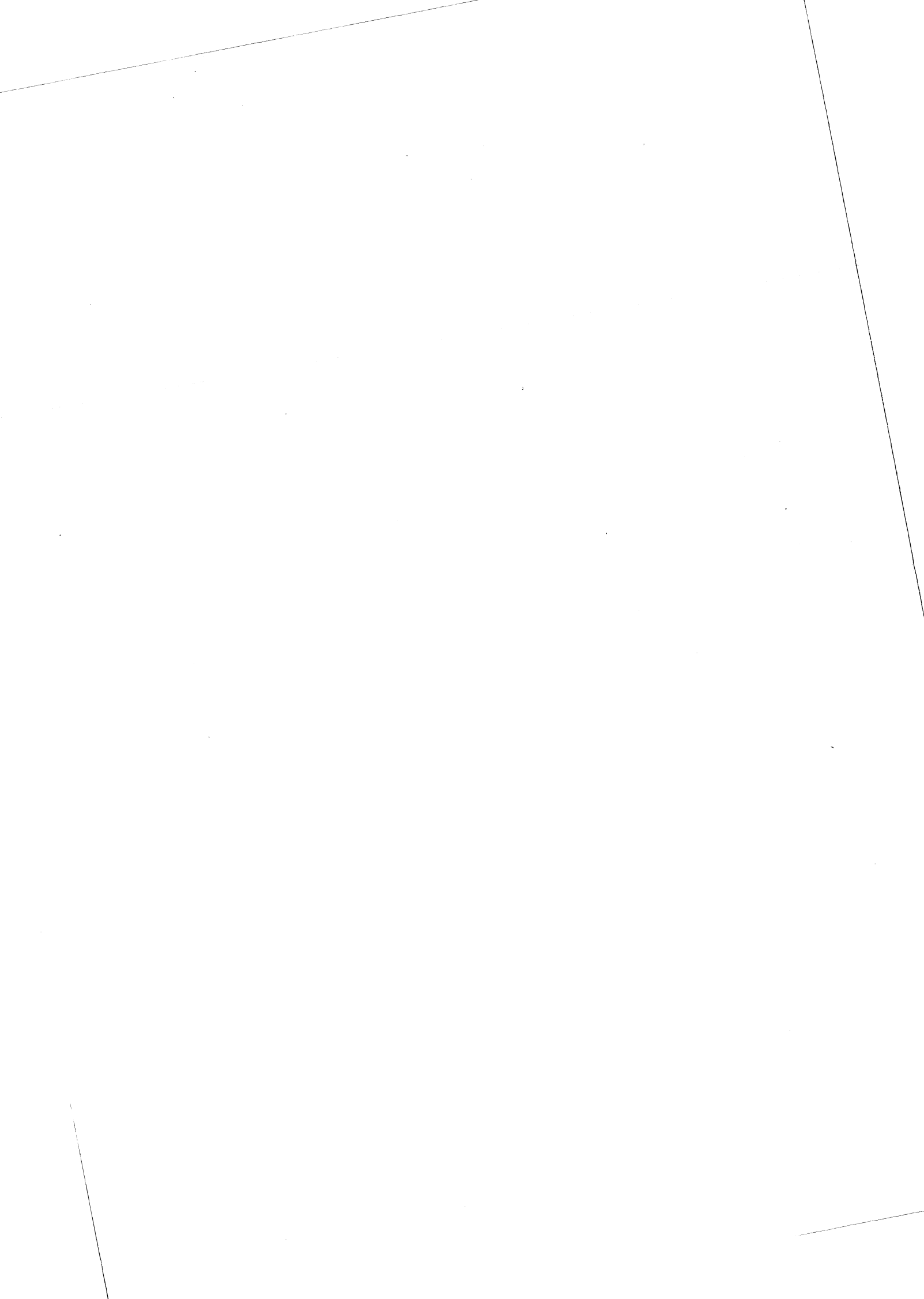

S O M E P R O B L E M S

O F

CO-OPERATIVE ORGANISATION

b y

Rob Paton

Autumn 1978.

Co-operatives Research Unit,
Systems Group,
Open University,
Walton Hall,
Milton Keynes MK7 6AA,
England.

PREFACE AND ACKNOWLEDGMENTS

This paper contains some reflections arising from the initial stages of a continuing research programme. Since there was little existing work on co-operatives this early work necessarily adopted a case-study approach. The discussion that follows is mainly based on the more obvious common features of these studies and the first draft was prepared before the fieldwork was even completed. It follows that the analysis, such as it is, does not emerge from and embody a coherent conceptual framework, and the claims made are erected on a rather limited empirical foundation. Readers must therefore assume at least the usual academic cautions and qualifications throughout, even when for brevity these have been omitted from the text.

An earlier version of this paper was read to the Alternative Technology Group of the Open University, and I am grateful for the comments and criticism it received. In addition, I am so massively indebted to my colleagues in the Co-operatives Research Unit that excusing them, as I must, from the paper's errors and inadequacies, hardly seems appropriate.

Finally, I am grateful to the Work Research Unit of the Department of Employment, whose financial support made the major studies possible.

Rob Paton,
Walton Hall.

Autumn 1978.

CONTENTS

	Page
Preface and Acknowledgments	1
1 Co-operative Organisation in Perspective	2
2 Problems Concerning Objectives	17
3 Problems Concerning the Two Systems of Control	22
4 Leadership, Entrepreneurs and Co-operation	32
5 Problems Concerning Work Organisation	37
6 Conflict in Co-operatives	48
7 Squaring Circles	52
8 Co-operative Organisation Reconsidered	68

References



1 CO-OPERATIVE ORGANISATION IN PERSPECTIVE

The Aims of the Paper

This paper is concerned with the organisational problems of what are popularly known as "worker co-operatives". For simplicity, these will be referred to as "co-operatives" and this should be taken as referring loosely to any enterprise in which ownership and control reside ultimately or overwhelmingly with employees, regardless of the particular legal framework through which this is achieved.

The aim is to analyse the obstacles to distinctively co-operative yet viable organisation and to outline some of the ways in which these difficulties may be tackled. The aim is not to discuss whether and under what conditions, co-operatives may be economically viable; in general terms the answer to such questions are rather obvious, and the more specific issue of financing and the "dilemma of collateral" has been discussed elsewhere¹. Nor, most emphatically, is the aim to describe some fixed organisational forms that an enterprise must mirror if it is to qualify as a "true" co-operative. Such an approach simply avoids all the central problems of individual and organisational change. Rather, the purpose is to pinpoint those distinctive organisational difficulties facing co-operatives trying to escape or stretch the strongly interconnected patterns of conventional company objectives, organisation, and attitudes. Thereafter, some suggestions are offered as to how these difficulties may best be overcome - or lived with.

This paper has been written for two audiences. In academic terms it is a first sweep through a rather disparate subject area, intended both to highlight aspects of co-operative organisation that must somehow be grasped in any conceptually more rigorous attempt to account for what happens in co-operatives; and also to suggest some possibilities of more manageable topics for future inquiry. On the other hand, it has also been written with some of those currently working in or promoting co-operatives in mind. The assumption, in this case, is that the clear statement of a problem is not just a preliminary to the real work of solving it, but a significant part of that work.

Is There Really a Problem Regarding Co-operative Organisation?

The recent upsurge of interest in co-operatives and the formation of many new co-operative enterprises conforms to a striking historical pattern: fifty years ago, one hundred years ago, and one hundred and fifty years ago, there were similar "peaks" of activity². But most of the co-operatives that were formed in these periods collapsed within a matter of years - indeed, within months, in many cases. Only some of the co-operative productive societies formed in the wave that peaked in the 1870's and 80's survived for long, although some survive to this day. The dire financial circumstances in which many of these enterprises were formed - in resistance to the introduction of new machinery, for example - offer a straightforward explanation for many of these rapid failures; but not all - or even most - were doomed from the start. And although the picture may not be as bleak as it appears³, it is also clear that the failure rate cannot be adequately explained simply in terms of initial undercapitalisation, technological change and recession. Although much more research is required, it does appear that the collapse

of many ventures reflected a failure to develop forms of organisation that reconciled the requirements of commercially sound management with an acceptable degree of employee participation. Indeed, some ventures appear not to have achieved either of these.

In more recent years a number of Common Ownership firms have been formed. Although the pattern may now be changing, it is clear that, until recently, all but the smallest Common Ownership firms have been commercially successful only when they were formed by their entrepreneur owners "handing over" an established concern to the collective body of employees - out of a social or religious rejection of conventional patterns of industrial ownership and control. However, it appears that despite their commercial strength, such companies have had the greatest difficulty in developing forms of organisation that involve more than just profit-sharing, a weak supervisory board and a participative management style. The same situation now seems to exist - and to be accepted as inevitable - in the surviving co-operative productive societies. It is true that in the case of some Common Ownership firms no more was intended; but this is certainly not true of all of them. Nor was it true of the Co-operative Productive Societies in their early days.

The fact is, therefore, that co-operatives have so far achieved only a small fraction of the hopes they have inspired - and continue to inspire. And given this historical record it is reasonable to have some doubts about the prospects for the current wave of co-operative ventures.

Co-operative Organisation in Other Countries

It may be argued that this rather pessimistic conclusion is achieved only by ignoring the international evidence. Currently, the Mondragon co-operatives in Northern Spain are receiving considerable attention. It is not possible in the paper to review fully even such limited international evidence as is available. However, one would expect the internal workings of co-operatives to be affected by the social context within which they occur. So it may be that certain aspects of British culture are not conducive to co-operative organisation - or, at least, pose additional problems (aspects of the class structure and trade union organisation and ideology, may be important in this regard). Meister⁴ has described how the social vitality of "self-managed" enterprises in Yugoslavia declined steadily as "consumerism" became a dominant trend, replacing the climate of self-reliant nationalism, bred of the war and Tito's break with Stalin. Likewise, it may very well be significant that throughout their development, the Mondragon co-operatives have been closely associated with socialist and nationalist ideals - a point given scant attention by some commentators⁵. At any rate, it should be clear that the conditions for successful co-operatives in other countries may not be sufficient, or may not easily be reproduced, in the United Kingdom.

In addition, there are questions regarding how successful these other examples are, as co-operatives. This paper is concerned with the obstacles to combining certain social objectives with financial strength. While the success of the Mondragon co-operatives is undeniable in the latter respect, much less has been said about the former. From the information available, it is not yet

clear that the results usually amount to more than a participatory management style, a weak supervisory board⁶ and the sharing of profits and losses. In contrast, the French experience is better documented⁷ and these reports confirm that there are severe difficulties associated with attempts at any further organisational innovation.

It should be stressed, however, that these points are not intended to belittle what has been achieved in other countries - nor to deny that much can be learned from experience elsewhere. They are intended simply as a caution against too optimistic an assessment of the prospects for co-operative organisation in the United Kingdom.

Managerial Views of Co-operative Organisation

It may, of course, be argued that the problems which this paper addresses are patently insoluble. According to this view, the achievements of co-operatives have been considerable - and it is unrealistic to expect more. Hence, those who have sought from co-operatives a far more radical transformation of industrial work involving the progressive elimination of drudgery, an erosion of the distinction between manual and non-manual work, and a marked change in the consciousness of employees - are not only dreamers, but proven as such by the historical record of the last one hundred and fifty years.

According to this view, the value of the co-operative framework - arguably it is reduced to no more than this - lies in the greater identification it promotes between the worker and his or her company. It is seen as useful

motivator and, more importantly, as reducing opposition to management. In more sophisticated versions, management's accountability to the workforce is also seen as valuable because it induces managers to adopt a participatory style "Common Ownership makes a good manager's job easier and a bad manager's job more difficult"⁸. Hence, from this viewpoint, the only distinctive problem confronting co-operatives concerns the rank and file members who may become aroused by raw co-operative ideals to make improper advances on the integrity of conventional management practice. But, in the long run, of course, such employees will be confronted with the "entrepreneurial realities" of the market place.

Clearly, this is a managerial view of co-operatives and co-operative organisation. Indeed, this perspective may well become a new ideology of progressive management⁹. It can supply a very plausible account of much that goes on in co-operatives and some justification for not viewing the problems of co-operative organisation in these terms must be offered. But it should be stressed, at the outset, that rejecting the managerial perspective does not imply a rejection of management, as such. Co-operation does not mean "no management" as the media appear sometimes to imply.

Suspending Ideological Judgment

There are a number of reasons for rejecting the managerial viewpoint. First, this view (like any ideology espoused by those in positions of power) is, to some extent, self-justifying. Managers who were firmly convinced of its soundness would presumably oppose initiatives that sought

to extend any further the influence of employees on commercially significant decisions that affected them. Hence this viewpoint may make further innovation more difficult, and generally foreclose the possibility of a variety of organisational practices emerging to suit the varying concerns of members in different co-operatives.

Moreover, in rejecting the view that today's good management practice (along with profit-sharing, a weak supervisory board and more "positive" employee attitudes) is the most that may be hoped for, it is not necessary to make any assumptions regarding the extent to which an organisational democracy may be possible. Some approximation to the co-operative dream may yet be realised; alternatively, it may very well turn out that, given the preferences of members, only the barest advances on participation in other well-managed firms elsewhere in industry, is possible. In other words, there is simply no need to take sides in the ideological debate. Indeed, it is quite unreal to consider what is feasible regarding the organisation of co-operatives without simultaneously considering their social and economic environment.

There is a further reason for refusing the managerial perspective on co-operatives. It is not how members themselves view the problem. Instead, by approaching the problem in terms of the extension of employee influence one is sharing the view of many members of co-operatives. The co-operative framework generates expectations of influence that cannot be ignored in any practical attempt at organisational development in co-operatives. It is also clear both that these expectations are a powerful motive for involvement in co-operative affairs, and that such involvement can, in

certain circumstances, produce very rapid learning on the part of the members concerned. Hence, some important conditions for serious attempts at organisational development frequently occur in co-operatives. To view this as a threat may be justified in some circumstances; but as a general reaction it seems excessively cautious.

On the other hand, by stressing the difficulties facing any attempt to extend employee influence, and maintaining an open mind on the ultimate feasibility of such efforts, one may still maintain the confidence of managers - and for anyone practically involved with co-operatives this is obviously important¹⁰. Indeed, it may be that attempts to extend participation are useful mainly in allowing members to come to terms with the very severe constraints they face, as these are posed by their own priorities and a competitive environment. Even if this should turn out to be the case, forms of participation that achieved this result might still be of value to co-operatives whose members may not readily accept managers' assertions to this effect.

What is Meant by "Co-operative Organisation"?

It has been argued that it is neither necessary nor desirable (especially for anyone actually involved with co-operatives) to assume that the achievements of established co-operatives in the United Kingdom to date represent all that is possible within such a framework. Since many of those working in or promoting co-operative ventures evidently hope for something more distinctive, it is worth examining the various obstacles to forms of organisation that combine commercial viability with a much increased measure of employee influence. But

what does this amount to in terms of co-operative organisation? What would such an organisation look like? As the research quickly discovered, terms such as "influence" and "power" are too slippery to provide much help:

"One can say that managerial authority is more or less complete at Fairblow within limits and so long as it is exercised in a particular way; but it must remain a matter of opinion whether this constitutes a net strengthening or a net weakening of management's position compared with what the situation might be in the absence of Common Ownership¹¹".

Moreover, to talk simply in terms of some desired level of employee influence suggests a rather static view of co-operative organisation. So, even if this turns out to be part of the answer, it does not go very far towards characterising "authentic" co-operative organisation.

So far, the idea of co-operative organisation has been developed negatively - it is "not just" what has been achieved so far. This is hardly satisfactory, but, in fact, there are reasonable grounds for proceeding on this basis and returning to the question later. In the first place, the meaning of "co-operation" is tied most closely to its use in describing arrangements or activities voluntarily undertaken by a limited number of individuals or small groups. In such cases, there is little doubt about the appropriate use of the term. But when used in reference to larger, more differentiated, organisations where the voluntary nature of the joint undertaking is reduced by the participants' need to earn a livelihood, then,

although it carries connotations from its established context, there are no clear rules for its use. Moreover, as has already been suggested, co-operatives find themselves in something of an ideological crossfire, being seen from different perspectives as the answer to quite different problems. If uses for the term are to be developed that do not lead to its immediate capture by one of a number of factions, then these uses will have to be grounded in the realities of what goes on in co-operatives. Only in this way can the concerns of those who work in co-operatives - and not just those who have hopes for them - be taken into account. For these reasons, the fleshing out of the term co-operative organisation is left till the end of the paper.

The Scope of the Discussion

It has already been suggested that the social and economic environment has a profound impact on the internal processes of co-operatives. The sort of trading relationships, the pace of technological change, labour traditions, the attitude of the State and the general social climate, not to mention religious and ideological currents within it - such factors affect the form in which problems arise and the way they are perceived. For example, as regards trading relationships, the specific uncertainties facing an enterprise are the basis for those distinct competences from which power can develop. Such competences may lie in the informal use of a range of personal contacts built up over time outside the firm, or in the application of particular management techniques to "rationalise" the uncertainty. But in either case, the capacity to

anticipate and match threats to the stability or continuity of important operational processes, will give those concerned pivotal roles in the organisation. So, clearly, the extent to which a co-operative can avoid, mitigate or accommodate the resulting dependence on those in key roles rests very much on the nature of the uncertainties facing the enterprise. Likewise, the social and cultural factors will affect the particular rationality within which problems are posed, decisions made, and activities structured.

The importance of these factors is shown particularly clearly in the success of the Federation of Northern Wholefood Co-operatives, whose constituent members have pre-empted and cultivated a particular market niche, thus creating for themselves a benign environment. Given this comparative predictability it has been possible, more or less, to avoid creating distinct competences. At the same time, the commitment to participatory decision-making and a particular working climate has been solidly buttressed by radical and "alternative" sub-cultures.

Hence, the internal processes of co-operatives cannot really be understood without reference to environmental factors, and a comprehensive treatment of co-operative organisation would require a characterisation of these different influences. Nevertheless, such a discussion is beyond the scope of this paper.

Apart from occasional asides, these environment influences have been disregarded, or assumed as permanently hostile. By narrowing the focus in this way, the subject becomes more manageable, but readers should be clear about the drawbacks in doing so.

Finally, the paper is primarily concerned with the problems of co-operatives that are not very small, since co-operatives with less than, say, seven working members hardly experience a whole range of organisational problems that beset even an enterprise of fifteen or twenty members.

Sources of Information

Before launching into the analysis, some comment must be made about the "data base" on which the discussion rests. This can be grouped as follows:

- (i) The results of research carried out by members of what is now the Co-operatives Research Unit. The first three of these are detailed case studies:

Fairblow Dynamics Ltd.

A light engineering firm of 200 employees¹².

Fakenham Enterprises Ltd.

The 20 strong women's co-operative, producing clothing and leather goods (since liquidated)¹³.

The Jewellery Co-operative.

A jewellery firm employing 40 people in two shops¹⁴.

The Print Finishing Co-operative.

A small firm of nine members providing print finishing services¹⁵.

The Building Co-operative.

A building firm of 30 employees.

- (ii) Conversations with numerous members of co-operatives, either in visiting them or at conferences; and conversations with other individuals researching or advising co-operatives.

For example, there is reference to "the fashion co-operative", which employs thirty people in the garment industry; and "the wholefood co-operative", employing twelve members in packaging and retailing wholefoods and associated products; and "the plant hire co-operative", employing thirty-five members in the construction industry.

Some of the information on the better-known co-operatives - Such as Kirby Manufacturing and Engineering, and Scott Bader Ltd. - has also been obtained in this way.

- (iii) Other existing literature ranging from Flanders et al's excellent study of the John Lewis Partnership, Hadley's account of Rowen (Onllwyn); Blum's descriptions of Scott Bader Ltd., Kirkham's historical analysis of co-operative productive societies¹⁷, to journalistic accounts in the press or periodicals.

A Rough Classification of Co-operatives

It follows that the discussion makes liberal use of anecdote and impression. This would be problem enough if co-operatives were all of a kind, differing only in terms of the usual factors, size, market, technology, etc. In fact, the character of co-operatives appears to be profoundly shaped by the circumstances of their formation and this makes generalisation even more difficult. In this respect it is useful to distinguish between three sorts of co-operatives:

- (a) "Endowed" Co-operatives; are those firms that have been "given away" to the employees by their founders. "Endowed" co-operatives are not usually unionised; they are usually well-established in financial and market terms.
- (b) "Defensive" Co-operatives; are those co-operatives formed by employees to preserve jobs on the closure of a factory or company. Union organisation may be very strong and the commercial situation desperate, owing to a history of under-capitalisation, poor management, transformed product markets, and so on.
- (c) "Constructive" Co-operatives; are those enterprises set up from scratch as co-operatives. They are, therefore, usually very small and combine all the problems of a new business and market penetration, with the problems of developing co-operative working

rationalised. In the latter regard, the members may have particularly high hopes from the co-operative. "Constructive" co-operatives come into existence in a number of different ways (some being promoted by those who wish to work in them, others being promoted "from outside" by individuals or agencies), but the "Alternative" co-operatives - whose members share a strong commitment to democratic decision-making and alternative styles of life - are an important and fairly distinct sub-category of constructive co-operatives.

These distinctions between different sorts of co-operatives are used in the discussion that follows.

2 PROBLEMS CONCERNING OBJECTIVES

In general terms, the objectives of conventional business organisations are fairly clear. The conventional business pursues economic goals mainly on the basis of remunerative power and a largely calculative involvement on the part of employees. To the extent that Trade Unions adopt predominantly economic demands (but struggles for "job control" should not be overlooked) they reinforce the primacy of economic objectives. The assessment of performance in such terms is fairly straightforward. Moreover, although employees are increasingly consulted on matters of policy and they may attempt to resist particular decisions, there is no question of their determining the direction of company activity or the style and structure of the organisation. Such strategic questions are not the legitimate concern of employees. Where well-organised trade unions are attempting to extend their influence to such strategic issues,¹⁸ this is in large-scale industry as opposed to the small or medium sized operations that are the province of co-operatives. Hence, in the sort of conventional enterprises with which co-operatives may be compared, company objectives are, in general terms, usually fairly clear, they are largely determined in a debate limited to senior personnel and widely (if pragmatically) accepted.

The Range of Objectives in Co-operatives

The same cannot be said of co-operatives. The co-operative framework opens a Pandora's box of competing and conflicting objectives. This is because, lacking outside shareholders, a co-operative has, in principle, some additional freedom

over the choice of objectives. A co-operative can decide not to maximise profits and not to expand, preferring other uses for its potential surpluses (uses which might not appeal to the shareholders in a conventional company). In practice, of course, this freedom may be more apparent than real: the enterprise may have very little room for manoeuvre in a competitive market. But, be that as it may, it is abundantly clear that the co-operative structure raises employees' expectations. In particular, members readily attribute to the co-operative many social objectives. It is commonly thought, for example, that a co-operative means greater job security (since members would not make some of their own number redundant), far greater employee influence on management decisions and a more friendly and relaxed social atmosphere. The following list gives some additional objectives (apart, of course, from a large bonus) which existing co-operatives have attempted to emphasise:

- the provision of employment for the disabled or other socially disadvantaged groups;
- training opportunities and the education of members, the elimination of separate management roles altogether;
- social projects (i.e. reduced charges for deserving individuals or groups, the support of development schemes in the Third World);
- convenient hours;
- interesting work;
- sexual equality;
- remunerative equality.

Furthermore, some co-operatives have set themselves the additional constraints of limiting production to environmentally sound, non-military, or "socially useful" products.

The Costs of Conflicting Objectives

It is obvious that the longer the list of objectives, the more difficult it is to find policies that will satisfy them all. At worst, every decision becomes a policy decision concerning the ideals of the enterprise, and the scope for disagreement and conflict is enormous - particularly since the performance of a co-operative in respect of many of the social objectives listed will be extremely difficult to assess. These problems may be most acute in constructive co-operatives, started with high ideals. Nor do shared "alternative" ideals provide the social cement to avoid these problems. A recent upheaval in one wholefood co-operative that resulted in members leaving, centred around just such a conflict of objectives: was the enterprise primarily a co-operative aiming to ensure an adequate living for members, including those with dependants, or was it aimed at providing a community service in the provision of moderately priced wholefood? The former goal implied a long term commitment by members, economically efficient work practices and higher wages; the latter was compatible with a transitory orientation among staff content with much lower wages and more haphazard, if congenial, working.

The problem of company objectives is much less acute in "endowed" co-operatives, where continuity with days when the enterprise was privately owned ensures that there is an established pattern of management. Nevertheless, many members may still believe that in a "true" co-operative things would be very different; and others express confusion over how much difference being a co-operative should, or could, make. As long as the co-operative rewards its members adequately in financial or other terms (i.e. relaxed atmosphere), there is little pressure for change from the workforce as a whole. But events at the jewellery and building co-operatives suggest that in financial difficulties such issues may be more widely discussed, with the extent of employee influence on decisions, the equity of salary differentials and the question of job security becoming contentious matters.

It is striking too that the problem of objectives can bedevil "defensive" co-operatives. Although the members of ten claim that the preservation of jobs is their overriding aim, nevertheless, many expect to be closely involved in decision-making and they often pursue a number of egalitarian policies as well. The results - as when there were three mass meetings (in company time) in two weeks on the subject of a co-operative's flat rate wages policy - may be costly.

Finally, it is worth pointing out that even the economic objectives of co-operatives are far from straightforward. If profits are distributed as bonus, then both bonus as a percent of wages and wage (rather than profit) maximisation are measures that can be increased more or less at the stroke of an accountant's pen.

In summary, therefore, co-operatives face a problem in that the very idea of a co-operative may mean very different things to different members. People expect more from co-operatives. Whether an attempt is made seriously to pursue a range of conflicting social and economic objectives, or whether instead, some members merely call for this to be done, it is clear that the frequent absence of a consensus over the significance of being a co-operative and the priority of different objectives can pose real problems. Since, in addition, rather more members of a co-operative (compared with a conventional enterprise) will hope or expect to influence these decisions, the task of generating and sustaining a consensus on objectives may be a major undertaking.

3 PROBLEMS CONCERNING THE TWO SYSTEMS OF CONTROL

A conventional business organisation is directed through a managerial hierarchy, in which some effort is directed towards ensuring that responsibilities are clearly specified. While this emphasis can lead to bureaucratic pathology in times of change, and to resistance from employees whose jobs have been stripped of discretion, such hierarchical authority systems can contain more "democratic" elements, such as project teams and autonomous work groups, thus avoiding the worst of the problems while preserving the overall structure. The lines of authority ending in a single point, remain clear. Moreover, since the concerns of collective bargaining are fairly well demarcated, most employees have stable and limited expectations regarding the extent of their influence. Hence, although real organisations are always messier than their counterparts in text books, the overall pattern of control is usually well understood and often very effective in its own terms.

Distinguishing the Two Systems of Control

The situation in co-operatives is rather different...since there are two systems of control: the conventional management hierarchy, on the one hand, and the representative procedures on the other. The scope of these two control systems and the relationship between them, can throw up a whole range of problems¹⁹. Many of these can be summed up in the question "Who has how much say on what sorts of decisions?" It is clear that "management must manage and that everyone cannot

decide everything" - but what is to be included in "managing" and how, for example, are commercial decisions that directly concern members, to be handled?

The problem does not appear in this form in smaller "alternative" ventures, where a serious effort is made to make decisions collectively on all but routine matters. This certainly takes time (one wholefood shop devotes most of the day it is closed to a meeting) and there may still be problems in agreeing the extent of individual discretion; but given small numbers and a commitment to this method, it can work quite adequately. In other words, since there is no management hierarchy, there is no problem concerning the scope of its authority in relation to the democratic procedures. But the problem does occur in the other sorts of co-operative and a number of ways of tackling it have been tried.

"Community" Versus "Commercial" Decisions

Some Common Ownership firms try to operate a distinction between community decisions and commercial decisions; but in practice this either leaves very little for the community or tends to break down in confusion and resentment. This is because the unambiguous community decisions are essentially rather trivial, including, usually, the disposal or surplus funds among good causes, the organisation of social activities and such matters as tea breaks and the cleanliness of toilets. In fact, a number of other decisions, such as redundancy policy, the size and distribution of the bonus, remuneration and hours of work, may be allocated to the community, although they all have substantial commercial implications. This happens for two reasons: firstly, on some of these

issues, interests may diverge and managers will want to ensure consent for the policy adopted. Secondly, managers wishing to generate confidence in the structure (and legitimate their own positions) are eager to see the Community deal with demonstrably important issues. In "good times" they may not discourage the Community meetings from dealing with a number of commercial issues that directly affect members. But, when times are hard and commercial considerations critical, they may use their powers as managers to keep effective control of similar issues, arguing if need be that it is their responsibility as managers. There are two specific problems. First, there is rarely any attempt to be explicit about the forms of participation employed. For example, if in a meeting a manager asks for members' opinions on a particular matter, is this because he considers the issue one which should be decided by the co-operative, or is he simply using the meeting as an opportunity to consult the members, although the responsibility remains his own? (And circumstances may prevent him acting on members' wishes.) Unless he is explicit, the members will probably believe the former is the case while the manager is frequently acting on the latter assumption. The result, of course, is members concluding that managers ignore the co-operative principles and do what they want to, anyway. Secondly, companies who operate on these principles do not explicitly tackle the question of who decides whether a decision is a commercial one or a community one. In practice, therefore, management are likely to decide. Hence managerial power over the organisation is often largely unaffected.

"Policy" Versus "Implementation"

A second and related way of tackling these problems involves a distinction between policy decisions and the implementation of policy. This has been used by members of the Co-operative Productive Federation, where great emphasis has been placed on limiting employee participation to general policy issues and preserving the freedom of management to implement their interpretation of policy as they think fit. There is no doubt that the distinction between policy and implementation is important; and also that (like anyone else) managers will not perform well if there are people peering over their shoulders commenting on their every move. On a matter like remuneration, for example, it will often make sense to formulate a policy (in terms of maximum differentials, comparability, fringe benefits, need or whatever) and then leave managers to implement it, subject to ratification or an appeals procedure.

Nevertheless, on its own, this principle is an inadequate basis for defining the scope of employee participation. First, the definition of policy may be very broad - especially if a range of social and economic objectives are being pursued - or it may be extremely narrow. Virtually any management issue that affects employees may be presented in policy terms; and conversely, substantive policy matters may be seen as issues concerning the implementation of some more general version of company policy. So, one is back with the problem of "Who decides whether a decision in the province of members or of managers?"

In addition, and more fundamentally, the restriction of employee participation to policy matters actually makes it less likely that employees will have an effective contribution to make on policy matters. This is because there are important areas of policy to which employees can make little contribution unless they have some awareness of the problems of implementation. In the extreme case, an employee whose work comprises the repetition on his own, of a short task cycle involving little discretion, will have no opportunity to experience such fundamental problems of management as co-ordination, trade-offs and uncertainty. Even if the issues are adequately explained, employees may very well lack the confidence to challenge proposals, or the capacity to outline alternatives. Nor will they be in a position to decide whether the agreed policies have been properly followed by managers - could more have been done regarding a particular concern, or are the managers right in claiming they have gone as far as circumstances allow?

The results in such circumstances are likely to be confusion and uncertainty on the part of representatives resulting often in a general sense of impotence and frustration. Feelings that will certainly be conveyed to the members they represent. Whether the representatives attempt to ~~resolve~~ their dilemma by intransigent demands or by abandoning the attempt and acquiescing in whatever is proposed, the result are unimpressive.

The "Competence Gap"

Clearly, one underlying problem is the difference in knowledge and experience of senior and ordinary members. This difference

is bound to exist and it is dangerous to underestimate it. But the size of this "competence gap" is crucial. Beyond a certain point formal involvement in policy-making is largely ineffective and possibly even counter-productive. The implication is clear enough: if employees are to be involved in decisions at a high level, then, as far as possible, they should have a broad basic awareness of the freedoms and constraints that exist for the company and the environment in which it operates. Formal teaching may provide part of this, but participation in other ways and at other levels may be a more powerful learning experience and is almost certainly a condition for any formal teaching to be really effective. Finally, it should be borne in mind that a sophisticated group of representatives who can influence company policy does not, in itself, ensure a smooth process of employee participation. The "competence gap" between them and the members they represent may become unbridgeable. Once again, therefore, to the extent that it increases employees' understanding of the requirements for effective operations, employee participation at other levels becomes important.

In short, any attempt to "tag on" participation to the top layer of traditional decision-making, would be fundamentally misconceived. How a systems functions at one level is inextricably bound up with the way it functions at other levels. So the distinction between policy-making and management is an inadequate basis for deciding the scope of employee participation in decision-making.

Informal Approaches

A number of smaller and medium sized co-operatives have tackled the problem in a much less formal way: employees may attempt to influence any decision that concerns them. This operates, in practice, by the very simple procedure of allowing employees to raise any matters they wish in general meetings that occur monthly or fortnightly. This is obviously closer to the practice of collective bargaining though it does not, of course, occur within an oppositional framework. And, as in collective bargaining, management may introduce issues they feel will, or should be, of concern to employees. This approach is flexible and ensures that matters of direct concern to employees are discussed. But it has some of the disadvantages of collective bargaining in so far as employees' concerns are promoted in a fragmented and negative way in opposing particular decisions. Since it is seldom possible to challenge one aspect of policy already being implemented, it may appear to employees, once again, that they are listened to, lectured and then ignored. There is no focussing on particular classes of decisions over a period of time in a way that would allow competence and confidence to build up among employees. A major part of this problem lies in the characteristics of general meetings that put a premium on the social skills and information that are the stuff of managers' work. Hence, managers almost always "win the argument". A further difficulty with this approach is that employees are often unclear about where they stand on a particular issue: is this a decision for the membership of the co-operative; or are they just being consulted? And, even if they are clear that it is a case of consultation, they may very well resent this. In larger

co-operatives, with representative structures, this practice of putting any matter of concern on the agenda looks even more like collective bargaining. If the representatives meet independently beforehand arguments and counter-arguments are likely to be well worked out in advance, thus avoiding the disadvantages of the general meeting. Indeed, provided they have adequate information, such preparatory meetings are likely to be a very effective learning situation. On the other hand, precisely because it is seen as being the equivalent of collective bargaining, this approach may not go beyond these concerns. Moreover, in the context of a larger co-operative, management is likely to try very hard to avoid conflict, often by sounding out opinion in advance and presenting proposals that go as far as they can towards meeting employees' expectations. When this happens, the representatives have been pre-empted and there is little left for them to be seen doing. Since it is only by modifying or overturning management proposals that representatives and members can achieve a demonstrable impact, the well-intentioned effort of managers to incorporate employees' concerns in their proposals may actually reduce the confidence that members have in the procedures¹⁸. Hence, there is unlikely to be much basis, except in time of crises, for any coherent opposition that might lead beyond liberal and participative management.

The Benefits of Uncertainty

In summary, there are serious problems with procedures for democratic involvement and control, which are based on distinction between commercial and community decisions, or policy and implementation, or even on the basis of "anything

that directly affects you which you don't like". When they are not too narrow in scope these approaches generate confusion over the participants' rights and responsibilities. Nevertheless, it should be noted that despite these difficulties, such approaches still make a difference in the way the managerial control system operates. The additional openness to questioning and criticism ensures that employee concerns are constantly borne in mind. So, even if the relationship between the managerial and representative control systems is problematical, the very existence of the latter affects the former.

Trade Unions and the Two Systems of Control

The final issue in this respect concerns the role of Trade Unions in the decision-making procedures of a co-operative enterprise. This arises mainly in "defensive" co-operatives, where a powerful trade union organisation may pre-date the co-operative and may have been largely responsible for its formation. In principle, such a situation presents at least a couple of useful ingredients for co-operative development: in the distinctive context of a co-operative, trade union ideals offer the possibility of employees and their representatives developing a stance that combines coherent opposition on some issues with co-operation and an acceptance of management policies on others. And secondly, the day-to-day negotiation with management on the implementation of policy, apart from safeguarding employee concerns at levels where a supervisory board cannot really be effective, offers a "training" for members that may enable them to operate more effectively at a

later date on an elected board. (In addition, union officials may have a valuable role as arbiters and in promoting links with other co-operatives.)

However, these possibilities, if they exist, appear, in practice, to be swamped by other factors. Given the changes in management style, acute financial difficulties and the apparent legitimisation of management decisions by a supervisory board often composed of union leaders, all of which occur in the formation of a "defensive" co-operative, the scope for union activity (including educational work) at the shop floor level may be very limited. If the initial upsurge of enthusiasm does not find productive outlets through the union, a gradual atrophy of shop floor organisation seems a real danger. Alternatively, once disillusion sets in, the union organisation may dispose employees and managers towards traditional attitudes once again (it would be useful to test these speculations with data from the records of members of the Co-operative Productive Federation, formed in the last century).

In summary, it is clear that the relationship between the two systems of control in co-operatives poses a number of problems, especially since employees may expect to become much more influential. However this relationship is handled, the procedures must be flexible enough to cope with changing circumstances; sufficiently transparent for members to know where they stand; and capable of involving members at different levels to varying degrees according to their interests and capacities.

4 LEADERSHIP, ENTREPREUNERS AND CO-OPERATION

This section concerns a nest of problems that many of the radicals involved in co-operatives prefer to ignore: entrepreneurial and leadership roles have undemocratic and individualist connotations that scarcely appeal to those interested in co-operative self-management. But radicals will overlook these factors at their peril; like it or not, starting a successful business is not easy and those individuals that, after the event, are referred to as entrepreneurs, do seem to possess a bundle of qualities - including fierce determination and a readiness, at times, to ignore completely other people's opinions - that are related to their success. Often they find it impossible to implement their ideas in established businesses and set up their own companies which they have difficulty in managing as soon as they become stable and substantial enterprises.

Of course, the classic entrepreneur is a rare bird and most businesses make do with some approximation to the species. The difficulty is that, given the degree of uncertainty, one cannot tell for sure, in advance, whether a particular individual is displaying foolish arrogance or business acumen; so it is not possible in a co-operative for labour to hire entrepreneurial flair in the same way that it hires capital. For every would-be entrepreneur, how many are lost on the way? Nevertheless, if co-operatives cannot offer a home to those with entrepreneurial qualities, they will face them as competitors instead.

This is precisely what seems to have happened at the Print Finishing Co-operative. One members of the original group quickly became frustrated by and sceptical of the organisation:

he left and set up a successful small partnership with an associate. In contrast, the promoter of that co-operative has candidly admitted that in setting up the business he was not really interested in making money - he wanted to make a social and political point. In the event, the Print Finishing Co-operative never really looked viable - and it hardly needs pointing out that many of those currently promoting co-operatives have similar motivations (in contrast, other small business men are generally very interested in making money).

This issue may be accentuated by an ideology or expectation that co-operatives should involve harmonious working and a high measure of consensus. If this is the case, then there may be particular problems in accommodating "difficult" individualists, especially if they are in position of authority. Such individuals may be accepted if they have, for example, technical skills that are clearly required, but entrepreneurial ability may not be so obvious and demonstrable.

Patterns of Leadership

Given these considerations, it is not surprising that in their early days, the more financially successful co-operatives are marked by a distinctive pattern of leadership. In each case, the leaders seem to have possessed a combination of personal qualities that enabled them to manage the tensions generated by the competing commercial and social principles on which co-operatives are founded. In "endowed" and "constructive" co-operatives, the founders and promoters of enduring co-operatives combine

entrepreneurial flair with a social vision: they have the commercial skills to establish the enterprise and the background, ideals and personal qualities to promote cohesion and a sense of social purpose. Ernest Bader of Scott Bader Limited, and the founders of the jewellery and plant hire co-operatives are three clear examples - there are plenty more (the founder of the wholefood co-operative, before it became a co-operative, may well be another).

As for the leadership of "defensive" co-operatives, the qualities required appear to be a shrewd appreciation of the basic commercial and "political" realities, along with the ability to organise support over a considerable period of time. In other words, the successful leaders have been able to deal credibly with government departments, customers, suppliers and sources of finance and, at the same time, lead a "militant" - and apparently hopeless - resistance by the rank and file employees.

If such leadership patterns are an important factor in establishing co-operatives, then they may also help in accounting for some of the difficulties they face once established. For, in either case, such initial and usually forceful leadership may well become an obstacle to the maturation of the company as a co-operative enterprise. In the case of "endowed" and "constructive" co-operatives, the presence of an individual who has given and done so much for the enterprise - as social cement (in binding it together) and as entrepreneurial knife (in carving out a share of the market) - may inhibit the members from taking responsibility. Indeed, it is perfectly understandable that such leaders often find it extremely difficult to relinquish their role and in one way or another they actually prevent the co-operative from

defining its own priorities and principles. One experienced proponent of co-operatives has gone so far as to suggest that the founder of any co-operative should leave after five years²⁰.

As regards "defensive" co-operatives, once these are established and trading, the original leaders must come to terms with a situation in which a primary requirement is sound commercial judgment. If they cannot provide this then either they must play a less prominent role in the co-operative, or the enterprise will sooner or later be in jeopardy. But it is often difficult for a leader to withdraw in this way and the increasing influence of commercial managers may (rightly or wrongly) be seen as a threat to the social ideals of the enterprise. Recent experience provides examples of such leaders withdrawing (with and without conflict and upheaval) and also of occasions when, for one reason or another, they did not withdraw: Meriden Motorcycles, and the Fashion Co-operative appear to be cases where the original leaders have withdrawn from their early prominence; while Fakenham Enterprises and, perhaps, Kirby Manufacturing and Engineering provide examples of the latter eventuality.

In summary, co-operatives - larger ones in particular - face additional problems of leadership in so far as rather exceptional qualities are required in the period when they are established, but these qualities are not the same as those that are required if the enterprise is to develop further in either social or commercial terms. These problems are certainly not insoluble as a number of co-operatives have demonstrated; but they are not trivial matters either. And although there are different

leadership requirements at different stages in the development of any company, the problems facing a co-operative in this respect may well be more severe.

The Continuing Problem

Finally, the problem of ensuring consent for major and unwelcome changes will remain after the early leadership problems have been resolved. Even if managers can "force through" their proposals, this will probably be at the expense of the co-operative's social development. Unfortunately, but perhaps significantly, there is little in the available experience of existing co-operatives that bears on this dilemma. The old co-operative productive societies that remain must have had to change direction several times in the last hundred years, but they are no longer paragons of participation. Some historical research is needed since they may have faced these problems in their more participative early days. For example, many co-operatives were formed in the face of redundancy arising from the introduction of new machinery. A few of these were able to transform themselves by introducing the same hated machinery, as it became obvious the older methods were doomed. One wonders whether the forms and extent of participation in these ventures had any bearing on which adapted and which did not.

5 PROBLEMS CONCERNING WORK ORGANISATION

A number of commentators have argued that the area of work organisation is one in which co-operatives will possess an advantage over their conventional competitors. Two main arguments have been advanced to this effect. First, it has been suggested that less supervision will be required in a co-operative because employees will be more committed to the goals of the organisation and better informed regarding what is required to achieve them. Secondly, it is argued that job enrichment experiments in conventional industry demonstrate that there is often considerable scope for socially and economically more efficient use to be made of the available human and technical resources. Since co-operatives commonly express a concern to make work as satisfying as possible, they should be quicker to take advantage of these opportunities. These arguments are attractive: there is indeed little doubt that conventional patterns of work organisation are often grossly inefficient and the advantages to a co-operative that introduced changes of this sort would be considerable.

First, one could expect improved productivity; second, the work would be more varied and interesting; this would be important in its own right, but to the extent that employees saw the enterprise as distinctive in an area that directly concerned them it might also be important in building support for the co-operative. Finally, to the extent that employees held greater responsibility for the connections of their work with that of others in the company they would have a taste of managerial problems and be better able to understand, and be involved in, higher level decisions. Indeed, one could argue that progressive job design is a necessary condition for the development of co-operative working relationships.

Limitations of the Job Enrichment Model

On closer examination, however, the picture is not quite so rosy. There are four reasons why the basically correct arguments given above will have rather limited application.

Firstly, most of the experiments referred to have taken place in very large scale industry, where tasks have been subdivided to an extremely high degree, often in conjunction with expensive capital equipment. Such situations are far less common in the small and medium sized firms that will provide the principle competition for an emerging co-operative sector. Precisely because production runs are generally shorter, such firms have usually required much greater flexibility. There is less scope for "enrichment" because the jobs have not been "improverished" to the same intensity. This is not to claim that there is no scope for job improvement in conventional small and medium sized firms. There probably is - but as yet it is not clear how much, and there are dangers in generalising from the experience of large scale industry. Hence, it remains uncertain whether co-operatives possess much of an advantage over their competitors in this sphere.

Secondly, job enrichment programmes require a considerable investment in training and in time for discussion and planning meetings. In addition, there must be other jobs for those displaced; these may be chargehands and foremen or simply employees no longer needed when flexibility reduces idle time. Finally, as regards the introduction of changes, it should be pointed out that many employees have felt threatened by the demands that job improvement places on them. Since programmes have been introduced to deal with severe problems, managers have been able to overcome

this reluctance with productivity awards - and doubtless some gentle pressure. It appears then, that in all these respects, the classic model of a job enrichment programme is inappropriate for smaller enterprises or co-operatives. They may be unable to afford the investment, unable to find other work for "displaced persons", less able to "pressure" employees, if (as was suggested above) the problems are economically less severe in smaller firms, then they will also be less able to provide a financial incentive.

Thirdly, the claims of "job enrichment" practitioners must not be confused with the reality. In many cases, the "improved" jobs still fall far short of the hopes of idealists who promote co-operatives. The experiments have been largely concerned with optimising, in economic terms, a socio-technical system; and the interest and satisfaction of work has been promoted to the extent that this has appeared conducive to improved productivity. Management appears increasingly willing to take a fairly long-term view of this; but generally it is not concerned with interesting work for its own sake. "Improved" jobs may be preferable to "unimproved" jobs - but they may still be tedious. In answer to this, it can be argued that the scope of job enrichment in conventional industry is restricted by the desire to maintain managerial control over the production processes. The extent to which this is true is uncertain, but obviously if this problem is reduced in co-operatives, then they have the opportunity to gain some ground on their competitors. Nevertheless, the point remains that the successful job redesign experiments provide little basis for an answer to the crucial question: to what extent can work be made more satisfying without heavy investment and given that no more than modest reductions in productivity

are likely to be tolerated? It may turn out that in many areas really significant improvements in job design are possible at little or no cost; but the reverse may equally well be the case and at present there is precious little evidence to go on. Job improvement, as practised in conventional industry, provides little indication one way or the other.

Fourthly, the simple argument that less supervision will be required, assumes that the ordinary members already have a strong commitment to the co-operative. But this certainly cannot be assumed. All that is known about incentive schemes demonstrates that the more directly the incentive is related to the employees individual behaviour, the more likely it is to affect that behaviour. In these terms a co-operative structure on its own - like profit sharing schemes - is unlikely to have much impact.

In short, although there may be scope for improved work organisation in co-operatives, it is not yet clear that this is the case, to any significant degree; and even if there is, the problems of introducing such changes may be considerable. These considerations are borne out, alas, by the evidence (such as it is) from co-operatives.

Larger "Endowed" Co-operatives

The larger and financially stronger co-operatives, like Fairblow and Scott Bader, would appear the most promising sites for any such developments. In fact, neither has made much progress. Generally, the "soft management" ensured by the co-operative framework precludes extreme "Taylorism" and

intense control in the organisation of work. This was certainly true at Fairblow, where employee control over the pace of work was an established feature of production and where labour flexibility and few really long runs ensured that there was a modicum of variety in the tasks to be performed. Likewise, a wide range of fringe benefits and a friendly social atmosphere prevent turnover or absenteeism from being problems, so there was little incentive for managers to introduce job improvement. At Scott Bader, the subject of job improvement surfaces regularly on the Community Council, according to the Commonwealth Secretary. But, equally regularly, nothing much happens - presumably because it promises to bring major disruption of established work roles and relationships, while promising only marginal benefits for managers.

What is more interesting is that both companies have considered the matter fairly closely. At Fairblow, a sub-committee of the Management Group was established to investigate the possibility with some support from senior managers. But the idea came to nothing and was quietly dropped.

According to Roger Hadley²², Scott Bader went further than this. Whilst conducting research at the company he was allowed to promote an experimental scheme of job enrichment. A particular area was chosen and after a slow start, the employees became enthusiastic about the changes, attending evening classes and training sessions to gain the necessary skills. As the project was maturing, there was a sudden surge in demand for the product of the area in question. Overtime was required, then more staff were brought in and two shifts introduced. Then, three shifts and finally a full "continental" system. The project collapsed, but not without a gesture of opposition; the staff complained and

asked what would happen if they refused to accept the shift working. They were told they would be moved to other work areas. Obviously, it is impossible to assess the extent to which this was "necessary", but Hadley expressed some doubt that the sales director negotiating the contract even knew about the consequences his deal would have. But whether the obstacles in any particular case are given by "real" market pressures, or simply by management attitudes regarding the overriding primacy of success, defined in technical-market terms, it is clear that there can be many a slip between well-meaning intentions and the reality of more satisfying work - even in the case of those companies best placed to achieve it.

"Defensive" Co-operatives

It is not surprising, therefore, that the larger "defensive" co-operatives have not made much progress in this area either. The investment cost of such schemes, if nothing else, is likely to be a major obstacle. Although there may well be more scope for change, a co-operative whose short staffed management is desperately trying to coax every minute of production it can from employees, is scarcely in a position to hire consultants and invite workers to take an hour or so off each week to plan work reorganisation. In addition, there is the problem that the need to preserve jobs and an allied trade union concern to maintain job demarcations, will make such changes less attractive. Nevertheless, the idea has been raised in one form or another at both Kirby Manufacturing and Engineering and at Meriden Motor Cycles. So far, it appears that the results have amounted to little more than a reduction in manning levels in particular areas.

Labour flexibility* has been seen negatively, as removing a constraint on management; it has not been seen positively, as a basis for entirely different patterns of work organisation. Whether more will be achieved if such co-operatives achieve greater financial strength remains to be seen.

More Ambitious Attempts in Smaller Co-operatives

Turning to smaller enterprises, the Jewellers Co-operative illustrates some different sorts of problems. Being a smaller company, where responsibilities are fitted around the staff available, there are not stable sets of identical work roles that are the usual target for improvement programmes.

Nevertheless, the company put considerable resources into training staff and increasing their responsibilities. Most radically, the buying of stock was largely decentralised to sales staff. In financial terms, the results were unimpressive: in addition to the costs of training, the fragmentation reduced the company's buying power, mistakes were made in stock selection and control, and the cost in staff time taken up meeting representatives, was significant. As the economic recession bit, the policy was jettisoned and staff were only responsible for starting the reorder process at fixed levels on stable lines.

* The issue of labour flexibility can easily become tied up with other issues. It is claimed that shortly after employees at Meriden agreed to take responsibility for cleanliness in their own work areas, an office cleaner was hired to tidy the offices of senior managers. This was not appreciated.

But the reaction of staff to these changes is even more significant. The job changes were interpreted as promotions, which offered prospects for further advancement. Younger staff developed ambitious hopes for the early achievement of posts as shop managers and assistant managers. And, as the company's plans for expansion were curtailed, an exodus began. It appears, therefore, that that the attempt to increase job interest and responsibility actually increased labour turnover. In addition, the abandonment of decentralisation demonstrated one immensely potent way of increasing job dissatisfaction.

Another small company that made ambitious attempts to change existing patterns of work organisation, was the building co-operative. The company started off with three innovations: it tried to operate with a far higher ratio of apprentices to skilled tradesmen; no-one was employed as a labourer (the promoter argued that labouring was demeaning and such work should be undertaken by any workers as required); and there was no foreman - instead, volunteer co-ordinators would take turns at ensuring the work was progressing properly.

The first of these innovations was soon abandoned; the tradesmen found it difficult to instruct and organise so many apprentices, whose productivity, therefore, did not increase fast enough to justify their continued employment. (Similar difficulties in industrial training have since been experienced by a number of co-operatives that have made use of grants from the Job Creation Programme.)

The second innovation lasted longer, but the difficulties it involved are instructive: whilst more or less anyone can do labouring, it requires experience to labour productively and with a minimum of effort. There is considerable judgment

involved in providing a steady supply of the correct mixes with the correct amount of moisture to several tradesmen at once, as the promoter himself discovered when he came to help out on site. In fact, the tradesmen's work rate was seriously reduced by abandoning practices that have evolved over many years as being highly productive. The point is not simply the obvious one that using skilled manpower on unskilled work is expensive; but that it may be significantly more expensive than is indicated by differences in wage rates. And this interpretation is borne out by the fact that when the building co-operative abandoned their principle and took on labourers, they were still prepared to pay them a tradesman's rate.

As for the attempt to manage without a site foreman this had some success but also ran into severe difficulties. Some individuals were able to achieve effective co-ordination and maintain a high degree of consensus. But the effort was time-consuming and extremely stressful for the co-ordinators concerned (indeed the most effective left the company for this reason), since employees were inclined to question the plans and decisions, if these were not exhaustively discussed beforehand. It has been suggested that ultimately this failure arose from the fact that the employees concerned had never known anything other than authoritarian supervision on building sites. The co-ordinators, therefore, did not have in their experience any models of participative management that they could copy; both they and the other employees tended to relapse into traditional antagonistic roles - except that the employees felt entitled to be more assertive²³.

These (rather depressing) examples are not intended to demonstrate the impossibility of innovations in the organisation of work in co-operatives. They are simply meant to illustrate some of the difficulties involved and to caution against too great an optimism about co-operatives being built on this particular stone. Job enrichment is certainly not something that can be "plugged in" to co-operatives as a straightforward way to tackle the problems of organisational development. It simply presents all these problems in a different form.

Work Organisation in "Alternative" Co-operatives

Finally, it is worth commenting on the experience of "alternative" co-operatives in this respect, since these enterprises commonly practise a high degree of job rotation - in order to avoid the power attendant on specialist roles. In many respects, the results have been impressive (though it should be remembered that the participants' willingness to accept low wages effectively loosens the market constraints). It is clear, for example, that more or less total job rotation is possible, at least in comparatively simple retailing operations. In areas such as accounting and buying, this practice has produced rapid learning on the part of many members, as they were "expected" to undertake duties they had previously considered arcane and mysterious. It is interesting, however, that this approach requires, if anything, more, rather than less, structure: the responsibilities, including the necessary communications, of each role must be carefully elaborated if they are to be effectively discharged by a succession of incumbents. How this practice will develop as the market for wholefoods

expands and the operations need to become more sophisticated in the face of greater competition, is a fascinating question that deserves close examination. So far, the collective and democratic principles appear to have been well preserved in the development of the wholefood warehousing co-operative for the Federation of Northern Wholefood Co-operatives. But the need to develop more sophisticated management techniques will present a real challenge. In addition, this form of organisation may bring with it two particular problems. First, there is the danger that everyone does everything badly - or at least laboriously. By rotating people quickly through routine tasks, one removes major incentive for people to develop the short cuts, dexterity and carefully arranged methods whereby those lumbered with such jobs permanently are able to keep one jump ahead of management. Secondly, it may be that such an organisation constitutes the worst possible arrangements as far as the introduction of changes are concerned; no-one has specific responsibility, but everyone is affected and must agree.

The issue, perhaps, comes down to whether such enterprise can maintain a climate of support and confidence in which members are willing and able to move rapidly along a number of learning curves, simultaneously, and where this is not realistic, whether they can develop more gradual or compromise versions of the same process that preserve the fluidity and transparency of the structure.

6 CONFLICT IN CO-OPERATIVES

Since avoiding the structured conflict of interest between owners and employees is one of the popular justifications for co-operatives, it is slightly ironic that in practice they should be marked by a considerable degree of both latent and expressed conflict. There are a number of reasons why this is the case: first, the co-operative structure raises employees' expectations of influence. But employees do not participate in order to agree with their managers - the reverse is far more likely. It is often particular decisions or events which trigger moderately interested members into activism in the hope of introducing changes. It is interesting to note, too, that the employees who are affected in this way do not appear only to be those who would normally be involved in trade union or similar activity. The co-operative framework seems to legitimise (or provoke) an involvement on the part of many who are "against" trade unions or who would otherwise avoid any involvement in industrial or company politics. They feel entitled to question decisions they would otherwise have accepted without comment - to this extent co-operatives take the lid off many areas of potential disagreement that are not otherwise seen as their proper concern. Secondly, the multiple objectives of co-operatives provide ample scope for dissension -- as should have been made clear in an earlier section of this paper. Such matters as differentials, company cars and profit-sharing bonus payments are frequent and sometimes bitter issues in many co-operatives.

Thirdly, the fact that co-operative structures are unfamiliar and uncommon means that there is inevitably a measure of confusion and uncertainty surrounding the rights and

responsibilities of members. Some of these difficulties have been described already in discussing the relationship between the two systems of control and it should be obvious that they are a fertile source of disagreement and conflict.

Finally, to the extent that members identify with their co-operative and become closely involved in its affairs, even minor disagreements may become that much more intense. This may arise through idealism or because the co-operative structure offers power and status to people whose experience of work characteristically denies either; but whatever the reasons, members may become personally bound up in the outcome of disagreements. Although these are speculations, some such process seem to be at work if one is to account for the relatively common pattern of a period of intense involvement by individuals (often requiring many extra hours of company related activity) followed by embittered withdrawal - with the person concerned possibly leaving the company altogether.

Each of these factors contrasts with the situation in most conventional companies - and especially with smaller firms. Even if such companies are unionised, "responsible" shop stewards often constitute an effective mechanism for handling conflict.

Hence, although conflict in co-operatives arises largely from problems already considered, it is still worth considering as an issue in its own right: the form and extent of conflict are likely to be unusual and mechanisms for its productive expression may very well be lacking (especially if it is considered anomalous or pathological in a co-operative).

The Fear of Reprisals

This latter point certainly appears to be the case in some co-operatives. At both Fairblow and the Jewellery Co-operatives, fears were expressed that if members expressed their dissent, it would be "held against them" by managers. (In the latter co-operative there were even claims that the prospects of one or two individuals had suffered in this way.) And in both enterprises, there was considerable unexpressed dissatisfaction - certainly far more than ever came out in the open, even if much was not of a particularly serious nature. Clearly, there is a genuine problem here, notwithstanding the protestations of managers that nothing of the sort would happen. The employees' fears must be wellfounded at least to the extent that managers cannot possibly keep separate their assessments of the same individual made in different contexts. But this works both ways - should managers deliberately ignore problem-solving or leadership qualities displayed in meetings? Unless one thinks so, then it is hard to argue that they should ignore, for example, an inability to comprehend the problems of others. On the other hand, what employees "give away" about themselves in meetings is likely to be marginal as regards considerations - far more is learned through knowledge of the person's day-to-day work. In borderline cases, an individual's contribution to meetings may be important - but it may be to the employees' advantage. If managers are aware of widespread discontent in the company, then the person with the courage to stand up and express it may very well have earned their appreciation. Indeed, in both these co-operatives, there were directors who claimed (rightly or wrongly) that the openness of the co-operative had been an important factor in their own personal success. Both claimed that their promotion from fairly junior positions had been aided by what they had learned from and by what they

had contributed to the meetings within the co-operative. Since one of these directors and another senior manager both remarked spontaneously that in retrospect they were appalled by the angry and ill-informed criticisms they had expressed, it is unlikely that if this was indeed a factor it operated simply through their expressions of agreement with the views of the board.

Unproductive Conflict

Nevertheless, it is clear that co-operatives face a problem in ensuring both that disagreement is expressed and that it is productively handled. The member who finally summons up the courage to ask a question in general meetings may learn something from a fluent reply, demonstrating that his or her fears were ungrounded, but the effect may also be to discourage any future questions. Moreover, those co-operatives - like the building co-operative, where criticism has been far more openly expressed - have not always used it effectively, either. Indeed, the problem in this case may be that so much criticism is being expressed that those concerned are forced into defensive postures and energy is dissipated in preparing for the next point scoring, emotive exchange. Such situations are not conducive to rapid learning either.

In summary, it is clear that co-operatives must come to terms with the fact that conflict is likely to be endemic, and how it is handled may largely determine the social development of the enterprise. Unless this issue is confronted, the alternatives appear to be differences which fester below the surface, threatening always to erupt in a wild "politicisation" of the company; or continual destructive clashes for as long as the enterprise can endure them without fracturing; or conventional attitudes and relationships.

7 SQUARING CIRCLES

The preceding chapters have described a number of aspects of the organisation of co-operatives that pose distinctive and profound problems. In this chapter, some ideas are presented for ways in which these problems may be tackled. The ideas range from high sounding statements of what, in principle, "seems to be needed" to a few more concrete suggestions for specific roles and procedures. This amalgam is unsatisfactory in many respects - beyond just the paucity of ideas. In the first place, although many of the ideas have in mind enterprises of about fifty people, no particular context is specified; since, in addition, few of the ideas have been tried in any serious fashion, this means the discussion constantly runs the risk of being (and indeed it may very well be) facile and unreal.

But the fundamental problem is that the effort to develop co-operative forms of organisation is an attempt to square a circle. On the one hand, it is obvious that an enormous amount of learning is required if people are to run even a moderately complex enterprise on a co-operative basis. In most commercial environments, any attempt at "instant self-management" is pretty well doomed to end either in collapse and recrimination or in a rapid reversion to conventional patterns of organisation. Even allowing for the massive under-utilisation of ability in most organisations, there are limits to the speed at which people can learn and attitudes change. So, the development of a co-operative must be gradual - a "withering away" of attitudes and relationships that obstruct a progressive extension of responsibility.

But, on the other hand, it is equally clear that one cannot engineer self management. People learn through their own activity and by making mistakes (psychologists would say that rebellion is required for maturation). It is the actual crises and conflicts that are the fuel for involvement and learning. There is this much truth in the claim that freedom cannot be given, it must be taken. Moreover, the dynamics of hierarchical structures - especially in a culture where status and success are attributed to those individuals who achieve dominance and build up material or financial resources - are such that these structures are most unlikely to "wither away".

It follows that a proposal that is not dangerous is likely to be ineffective - or it may perhaps be both. But if one descends from such generalised arguments - with their misleading air of finality - to specific situations where people are tackling these problems in day-to-day terms, the difficulties are less conclusive. Members do learn, co-operatives do survive, and different ways of tackling the problems described are explored. Moreover, there are grounds for believing that the social environment of co-operatives is becoming less hostile and at the same time a number of proposals are being made of ways to provide economic support or shelter for co-operatives, especially in their early days.

However inappropriate many of the ideas that follow are, in particular situations those involved may still usefully employ or adapt, some of the suggestions. And it should be stressed again that these ideas are not offered as fixed structures to embody "true" co-operation but as crutches and spurs for a process of development; co-operatives must explore and experiment if they are to evolve forms of organisation that match their unusual objectives. The need is for more (and

more creative) ideas, as a pool to draw on. There is no way any proposal for an organisational change can be mechanically applied, so the suggestions that follow would always have to be modified and developed - and quite possibly discarded in the particular circumstances. The difficulties of escaping conventional thinking about organisation constitute far more of a problem than the danger that a particular madcap idea will be blindly applied, to the ruin of all concerned.

Some General Requirements

The first point is very general and follows directly from the definition of the problem in dynamic terms; the way in which a co-operative is organised should be transparent and amenable to deliberate change and development. That is to say, confusion and tradition regarding the "proper" way of participating are sure obstacles; whatever vehicle expresses members' views must be seized on and worked with. But ideally one could aim for an explicit rationale, in terms of the underlying structural problem, that would justify a range of procedures, the particular set chosen depending on the developing concerns and capacities of members.

Secondly, given the range of objectives pursued by co-operatives and varying concerns and attitudes of members, mechanisms are required for both the generation of consensus and the articulation of conflict. These must be developed in tandem since one without the other will be either empty or dangerous.

Thirdly, since co-operatives embody (to a far greater extent than conventional enterprises) a dilemma of competing objectives, that dilemma must be structured into the co-operative at all levels. This point is a development of the conclusion of Emery and the Tavistock group that the goals of the parts must be the goals of the whole, if a

system is to function adequately. As far as possible the goals of individuals must match the goals of the company and the resulting dilemmas of the company must confront the individuals. This is essential for both cohesion and learning.

Many of the more specific comment that follow attempt to fill out these three very general points.

Accepting Conflict and Developing Consensus

Given the range of objectives pursued by co-operatives, some procedure for generating at least provisional agreement on priorities is required. The idealism that helps establish a co-operative encourages members to want a bit more of everything but what is most important given the constraints and opportunities? The only way this can be answered is by confronting members with some approximation to the basic choices. The procedure might be as simple as a ranking exercise conducted in the light of a document listing possible objectives and outlining current circumstances. It would, of course, need to be repeated fairly regularly to reflect the changing objectives of members and changing circumstances. Such exercises can be valuable in generating consensus and in increasing the awareness of differences that do exist. Moreover, they embody and teach a perspective on disagreements, that is valuable even if a particular outcome does not greatly help in the resolution of the current dilemma.

Even where the size of the company allows fairly frequent general meetings, the use of committees is still essential. Such smaller groupings reduce the power of social skills

and are a more effective learning situation. In addition the use of committees allows for degrees of involvement to match the degree of interest of different members. Finally, a committee concerned with a particular area means that the members will be specialising and to that extent can develop familiarity and confidence with the issues more quickly.

Likewise even in fairly small companies it is important that "non-managerial" members meet independently if they wish to. Once again such meetings are often a far more effective learning situation: it is easier to admit to a peer that one has been mistaken or that one does not understand. In addition, of course, non-managerial members can speak more freely in such meetings without fear of "reprisals", so that there is a much better chance of complaints and disagreements being fully aired.

Another way of ensuring that differences are brought into the open is by creating a role to do so. Since many small co-operatives may not be unionised a role that works in a similar way to that of shop steward may be helpful. For example, one of the representatives or office bearers could have specific responsibility for presenting grievances - regardless of his own opinion (thereby absolving him or her from responsibility). The "advocate's" task would be to help prepare and present the case in the strongest way possible. Hence, those with complaints who were otherwise unwilling to voice them, would be guaranteed assistance by a clear presentation of their point of view.

Living With the Ambiguity of Two Control Systems

A procedure is required to select decisions of interest to employees and allocate them to appropriate forms of participation. Only by tackling the problem explicitly can people know where they stand and yet be able to modify existing practice in line with developments. Such a procedure could operate in a number of ways: for example, the selection and allocation of decisions could be carried out by a representative committee on the basis of a list of "matters pending" provided by managers. Alternatively, the representatives could provide senior managers with the criteria or order of priority for the selection of matters in which members wished to be involved. In either case the first result of such a procedure would be to make members consider which matters they were most concerned to influence, given that unless every evening is to be spent in meetings some, and probably many, issues will have to be left to managers. Secondly, the procedure might prevent matters of no particular concern to members being brought to meetings and aimlessly discussed at the expense of other concerns. Thirdly, by selecting particular classes of decisions to focus upon, members might develop a fuller appreciation of the issues involved and make more of a contribution to their resolution. In addition, employees would be more likely to be involved before, rather than after, management had made decisions and started implementing them.

But perhaps the principal pay-off from any such procedure would be in the requirement that different forms of participation be distinguished. The different ways in which people can be involved in a decision can be described on two dimensions: first, who is involved - all the members

in a general meeting, a department, a committee of members, etc. Secondly, there is the degree of power: at one extreme a matter may be left as entirely the responsibility of the managers concerned; and at the other extreme a decision may be treated as one for the co-operative's members to settle (either directly or through representatives) in which managers have no more "say" than anyone else. In between these "pure" cases there are a number of possibilities: for example before making decisions management may consult members even though the responsibility remains firmly their own, or joint decision-making may be operated, in which the decision must be acceptable to both members and management -- either side may veto.

Clearly, there is a range of possibilities for employee involvement and the procedure suggested would mean that these different forms of participation were spelt out. Clarity on the matter of "how much say" people have on different issues might well on its own avoid many misunderstandings. In addition, delineating these different forms focuses attention on the different sorts of decisions that arise - in order that they are handled in suitable ways. The obvious case is urgent decisions for which elaborate participation is clearly inappropriate. But there are other criteria - such as the degree of expertise involved and the extent to which a decision is likely to have substantial commercial implications. Hopefully members deciding how they could most effectively use their (limited) time and effort would bear these factors in mind. For example, if a commercially important decision was pending, it might be better simply to be consulted (and deal more thoroughly with another matter) if opting for a fuller involvement took up an inordinate time as the full complexity was explained. Employees do

not make much contribution if most of the meeting is taken up in making sense of briefing papers. On the other hand, by being consulted, members may still learn something about the issue so that in the future, as capacities develop joint decision-making on a similar issue may become realistic and worthwhile.

Since this procedure may appear hopelessly cumbersome and elaborate, some additional comments are required. First, decisions regarding which matters employees will be involved in, and how are made anyway. Indeed, the major part of one general meeting at the Jewellery co-operative was taken up in deciding how a particular very difficult decision was to be handled. But usually such "decisions about decisions" are made far more haphazardly without much regard to the relevant factors and with considerable ambiguity over the procedure chosen. Moreover, "allocation" decisions are usually made by management. Once established a procedure such as this would not take up much time, though it might well take some getting used to. A flow chart, like that given in Figure 1 might help to speed up the process. Finally, this procedure would not have to be implemented in full. And if it were discarded as too cumbersome (a fixed structure being preferred) its consideration would still have raised important questions concerning employee involvement. So, as with the suggestion for an exercise ranking objectives in order of priority, the value of this suggestion lies as much in the perspective it conveys as in how and to what extent it is actually used.

On the other hand this approach does involve one substantial difficulty: it assumes that decisions are fairly discrete events, the occurrence and implications of which can be predicted without difficulty. This is often the case; but certainly not always. And it would be foolish to pretend

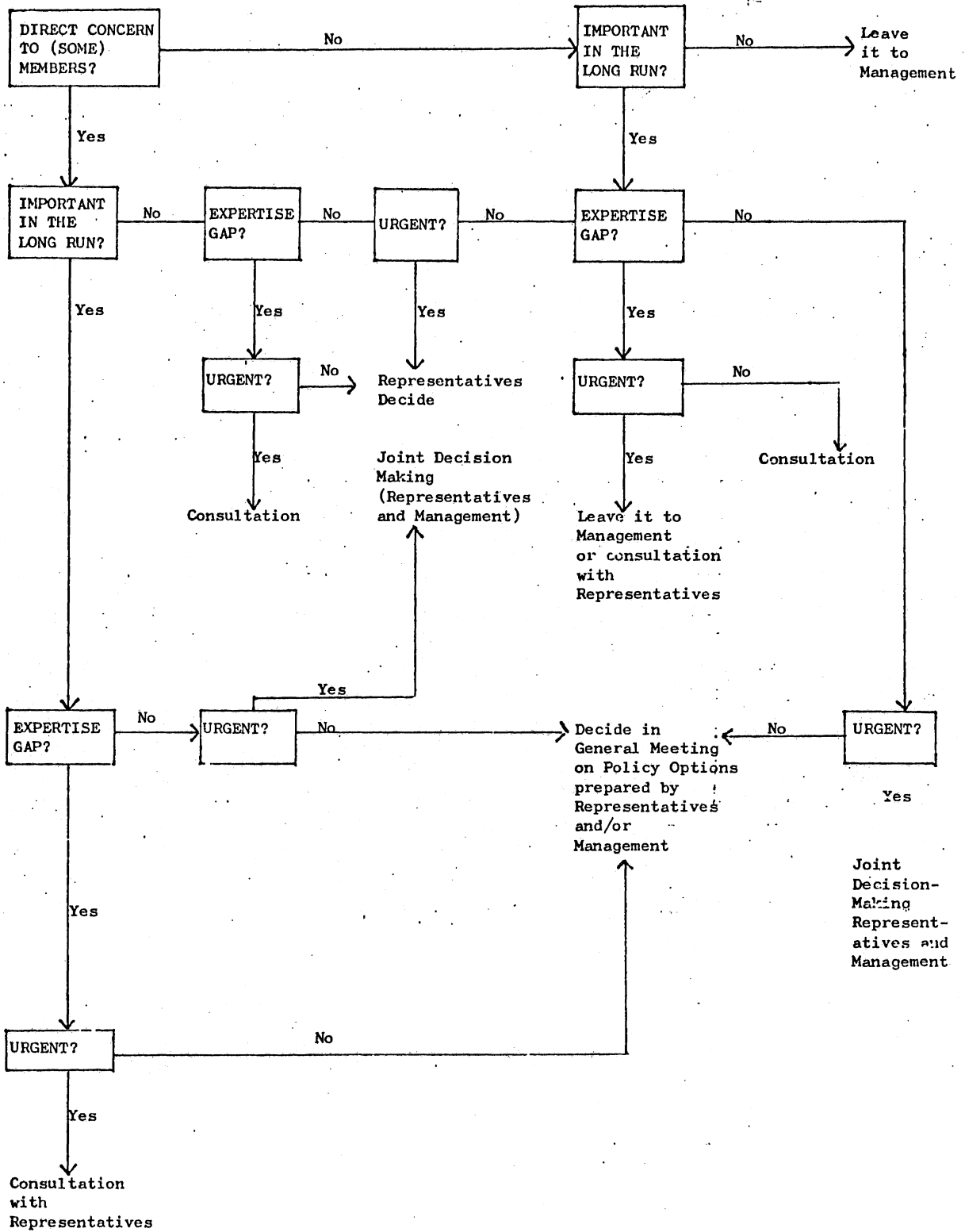

FIGURE 1 : SELECTING DECISIONS AND FORMS OF PARTICIPATION

Each question is a matter of degree - the object is to help choose the best form for participation, given a (severe) time constraint.

that "allocation" decisions made within this procedure could always be final and the best possible; like so many business decisions, these would also have to be made under a large measure of uncertainty.

The preceding ideas involve the attempt to distinguish clearly between the roles of representatives and managers in higher level decision-making and to embody the competing objectives of the enterprises in a structure that will preserve this fundamental tension. Thus, the representatives' first (but not only) responsibility is for the concerns of the members and the social objectives of the company; the managers' first responsibility is for the commercial aspects of the enterprise. If representatives pre-empt commercial issues or if managers decide on social objectives and the concerns of members then the results are likely to be either commercial decline on the one hand or paternalism on the other.

Participation at Other Levels

However this "bicameral" structure cannot be repeated at every level without being hopelessly over-elaborate. Hence, at lower levels some other approach must be used to build in the competing objectives and ensure that members directly experience this fundamental dilemma. The obvious way to do this would be through the creation of autonomous work groups. Especially if a portion of the firm's trading surplus could be allocated to them, they might have some limited discretion regarding the use of "slack" - those involved would then decide whether to aim for the biggest possible bonus, to spend more time on participative decision-making, in training, shorter hours, or whatever. But any such scheme will require the development of methods of group working appropriate for smaller enterprises. The difficulty is that the smaller scale of operations means there is not

to anything like the same extent a rationalised structure of work roles existing independently of the particular incumbents. Instead, considerable flexibility is required and tasks vary according to current requirements. The competencies and responsibilities of individuals overlap far more and the jobs are fitted around the particular abilities of the people concerned.

In such circumstances, group working might have to be based on principles such as these:

- (a) groups would be formed on the basis of size and physical proximity, to allow ready communication among all members;
- (b) a "network" pattern of overlapping competencies would have to be deliberately developed over time; this network would have to extend across group lines;
- (c) senior staff would have no day-to-day supervisory function but are available to advise on, or take over, "problems" and to undertake training.
- (d) what is required of the group is clearly spelled out, and advance warning is given of additional work in particular areas;
- (e) those whose competencies overlap group boundaries are responsible for settling competing claims on manpower between those groups in conjunction with group leaders;
- (f) the role of group leader might rotate among those who are not newcomers. The role is essentially that of being a contact with management and thus involves bringing particular points to the attention of the group.

- (g) regular meetings would be held of managers and group leaders to plan particular events and point out any respects in which groups were not maintaining agreed standards;
- (h) information systems would have to be modified to allow as clear a picture of performance as possible to be fed back to the group.

Clearly such a structure would only be feasible where the task structure allowed such groupings - if a large number of people with a considerable span of competence are involved in quite closely integrated activities then it is hard to see how these principles could be applied.

Indeed, it may be rare for even the limited autonomy suggested to be feasible. But the rationale for these points is an attempt to eliminate day-to-day supervision and direction of staff by establishing teams capable of organising themselves, thus leaving managers with specialist training and planning roles. The approach thus differs from most job improvement in so far as the additional tasks of group members are entirely in the area of management functions. Group members might choose or even be encouraged to widen the range of tasks they were competent to undertake, but as has already been pointed out, a considerable measure of flexibility is required under conventional arrangements so the necessary increase in skills might not be great.

There is not much one can say about a suggestion of this sort without reference to the particular activities of a given production unit. However, even if some such principles can be applied in some situations, there is definitely one serious problem; it is not at all clear that the

elimination of supervision is a sufficient motive for either management or employees to undertake such a development. The other benefits - if they exist - would certainly not be apparent in advance.

The alternative to group working of this sort would be decentralisation in a different form: the creation of federations of productive units sharing some central management services. These units might still be hierarchical, but they would be small and informal. Since many businesses are engaged in a number of related but not particularly integrated activities, this scheme may have some applicability. But without experimentation one can only speculate on the balance of advantages and disadvantages.

Information Systems for Co-operatives

Both these schemes would require that the information systems be radically reworked. Characteristically, management information systems are designed to ensure adequate control can be exercised over a company's operations. The information needs of employees are not just related to decision-making and there would have to be changes both in the information collected and the way it was presented. The information that would allow work groups to manage themselves, would obviously be one important area but the availability of up-to-date and basic data that would allow and promote a comprehension of the commercial position of the enterprise would also be important. The level of detail of management accounts and forecasts is sometimes overwhelming for employees. This is a topic that requires a separate discussion and far close investigation, but it may be an area where micro-processors will have a liberatory potential²⁴.

Training

There are a number of areas in which short training courses could be developed to suit the needs of small and medium sized co-operatives. An introduction to the basics of how the business would work would be one and guidance on reading a balance sheet and interpreting indicators might be another. More adventurously, social skills training might be useful, particularly as regards the giving and receiving of criticism. Once again any such programme would have to be developed with the specific needs of co-operatives in mind. So far, the boom in social skills training has not gone much beyond the management of large companies and the approaches used (such as Transactional Analysis) are still somewhat elaborate and intellectually "heavy". A problem-oriented approach focussing on particular, difficult events in the working relationships of members might be more to the point (a number of alternative co-operatives are already experimenting with different "encounter" techniques).

Such training would have a considerable amount to recommend it: the direct benefit would presumably arise from the more productive expression and use of conflict. But it might receive approval for other reasons - managers often claim that they find it useful in non-work relationships as well, and appreciate it for this reason. In addition, since they are fairly independent of expertise and qualifications, such skills may have an inherently democratic influence (it is said that when one large company experimentally taught Transactional Analysis with the aim of reduced friction with "awkward customers", those concerned promptly started applying it to their supervisors). Certainly this would be one area in which co-operatives could become distinctive - other small and medium sized firms are unlikely to undertake such training.

Management in Co-operatives

The problems of leadership and large "competence gaps" can only be solved by establishing the conditions for trust. But one must distinguish between the automatic and uncritical trust of "deferential" workers in many small firms - a response to powerlessness - and the trust that is earned by a demonstrable competence and a sympathetic respect for the other members of the co-operative. The second situation is indicated by members questioning and challenging proposals and, indeed, being quite willing to reject them on many matters. The acceptance of commercial expertise occurs in a dynamic relationship involving disagreement and conflict as well as agreement and consensus. If earning such trust is clearly a requirement for senior managers or entrepreneurs who wish to be effective within a co-operative then this may be an incentive for them to allow or undertake organisational innovations on the "educate our masters" principle. On the other hand, a common reaction, at least in moments of stress, seems instead to be an attempt to "mystify our masters" - facts and figures, explanations, elaborations, possible pitfalls and advantages are presented not so that members can increase their comprehension of the issues, but in order to demonstrate the overwhelming complexity of the problem - and thus the importance of giving managers full discretion. Such an approach may be tactically successful, but it provides no long-term solution. Hence, co-operative working will require considerable changes in management behaviour and attitudes as well. Indeed, the commitment of senior managers may be important conditions for the development of co-operative working²⁵ - it may be one way of "squaring the circle" and ensuring that a gradual approach to co-operative development is sustained with crises and conflicts being seen as an opportunity for learning rather than an indication of failure and the need to retreat.

In general, the views and attitudes of managers in co-operatives are a neglected area and the changes required of managers if co-operative working relationships are to develop deserve serious consideration (for example: what would be the implications for managers of group working, or a federal structure, as suggested; what satisfactions and additional stresses would their jobs then involve?). The usual preoccupation with how much the workers have to learn if they are to realise what is best for them, point in a very paternalist direction.

Overcoming the Isolation of Co-operatives

The preceding observation - that one should not think of all these developments being done to employees, leads to a final suggestion: strong links between the rank and file members of co-operatives are required.

Because there are not many of them, co-operatives are often isolated and the members do not have the same opportunity as other workers to discuss issues with people in comparable situations and to learn about the different ways in which similar problems have been tackled. Since the development of co-operative working depends on how the problems that the co-operative structure itself generates are tackled, it is vital that members are aware of a variety of ideas and practises. Contact between the rank and file members of different co-operatives is the only way to ensure this. Without such contact, managers - among whom contacts and meetings are much more common - will make all the running. Since their motives may (rightly or wrongly) be held in question by other members, the diffusion and development of organisational innovations will be restricted if suggestions for changes and information about them come only from managers.

In addition, it appears that such meetings may be important in sustaining the efforts of activists and creating an awareness of a wider current of social change that those involved are a part of.

Conclusion : Learning from Others

The preceding analysis and suggestions have all arisen, more or less directly, from an involvement with co-operatives. They certainly do not exhaust the possibilities. In particular, the theory and practice of organisational development, the experience of some of the more radical "work democratisation" projects in both Scandinavia and Britain, and the writing of some community activists and organisers offer much that is relevant to the problems of co-operative organisation. Relating these ideas to the particular context of co-operatives remains to be done. This may not always be straightforward - just as action-research in co-operatives presented some particular difficulties²⁶ - but there is considerable promise, nonetheless.

8 CO-OPERATIVE ORGANISATION RECONSIDERED

This paper has been concerned with the problems and difficulties that members of co-operatives often experience as they try to shape their organisational relationships in ways that match their varied, divergent and developing concerns. As such, the discussion has drawn on numerous examples of failure, frustration, dissatisfaction, confusion and straightforward blunder. If the tone has, on occasions, been a little depressing, this was inevitable, given the subject. It does not follow that co-operatives "do not work" nor that co-operatives have a monopoly of difficulties simply because they have been the subject of discussion. One could also write a paper on the achievements of co-operative organisation; since it would discuss the jobs saved and created, the bonuses earned, the pride and ferocious commitment often generated, the dramatic broadening of horizons that often occurs, and so on, it would have a very different tone.

These points beg a tangled question that was deliberately left in abeyance at the start of the paper: what constitutes effective co-operative organisation? Clearly, an answer, albeit a general and imprecise one, has been developing implicitly throughout the paper and the purpose of this section is to draw it out.

Ideals of Co-operation

How people think about co-operatives reflects and embodies their value positions. Currently, co-operatives are all things to all men, being endorsed by those holding a wide range of political persuasions.

Simplifying massively, four models or images of co-operative organisation can be distinguished. The first is of the

co-operative as a harmonious team. In this view success is understood primarily in commercial or remunerative terms, with the co-operative ensuring motivation and legitimate authority. Secondly, there is the image of the co-operative as a political community. Given remuneration in line with members' expectations, the organisation is considered in terms of the processes of decision-making - participation, control and consciousness become key concerns. Thirdly, there is the model of the moral community in which the co-operative embodies religious or social ideals: the extent to which day-to-day practices express a respect for persons and the quality of the relationship of members to each other and the natural world, become the focus. Fourthly, there is the image of defiant mutual protection: the co-operative succeeds to the extent that livelihoods are preserved, expert forecasts confounded, and an ethos of egalitarian solidarity sustained.

Such ideals are important in lots of ways - in generating support for co-operatives and in sustaining the efforts of members on occasions. Moreover, in the context of discussions of policy or of the role and impact of co-operatives in general, these hopes and ideals are central - in so far as all such discussions, implicitly or explicitly, are about the values one would like to see embodied in and nurtured by social economic and institutional arrangements. Hence, there can be no complaints about discussing co-operatives generally within a frame of reference derived from one or more of these ideals.

Difficulties with Ideal-Derived Frames of Reference

However, when such frames of reference are used in thinking about the organisation of particular co-operatives, then a number of difficulties do arise.

The first is that these ideals are inevitably somewhat remote and, as was suggested in the first section of this paper, they may be rather difficult to translate into day-to-day terms. The example given there concerned power and authority, but even the "harmonious team" viewpoint is very slippery - there is now a substantial body of opinion that sees a measure of conflict and disagreement as essential in many organisational contexts. So, when it comes to thinking about the organisation of particular co-operatives, these ideals do not offer much practical guidance.

Secondly, the frame of reference adopted by an outsider may not match those of the members of the co-operative - it may not represent what the members are trying to do. In practice, thinking about a co-operative in these terms often leads to the conclusion that "it is not really a co-operative at all" - a remark that has been made by members of each of the three types of co-operatives about co-operatives of another sort, as well as by many who are not members of co-operatives. Of course, such a remark may be perfectly justified, if the constitutional procedures have become entirely empty, and awareness that the enterprise is (legally) a co-operative is steadily declining. But usually, the remark is applied to a co-operative whose members have, more or less deliberately given a different meaning to the term from that held by the person making the remark. Even if the frame of reference adopted is also used to some extent, by some of the members, this is hardly enough. Members probably endorse a number of these ideals, more or less strongly,

depending on context. Hence, the use of ideal-derived notions of co-operative organisation may prejudge questions regarding the feasibility and desirability of particular ideals, in the given circumstances and may lead to disregarding whatever choices a co-operative has made regarding social and economic priorities.

(On the other hand, it is equally unsatisfactory to consider co-operative organisation entirely in terms of the particular objectives that co-operatives happen to be pursuing. This relativist position ignores the way in which objectives are selected - an important process in any organisation and one which may be conducted more or less "co-operatively".)

A third reason why these "ideal-derived" frames of reference are unsatisfactory for thinking about co-operative organisations is that they are too static. To consider particular co-operatives in terms of, say, the degree of employee influence or control, does not discriminate between, for example, a co-operative where managerial influence is very high and there is little change in roles and relationships, on the one hand, and a co-operative where managerial influence is equally high but considerable changes are under way in the roles and relationships of members on the other. Thinking in terms of fixed ideals usually leads to notions of the proper structures for co-operative organisation and ignores the processes that must take place that must take place if the co-operative is to develop as a co-operative.

The final reason why these ideal-derived frames of reference are unsatisfactory, when considering the organisation of particular co-operatives, is that they seem quickly to lead into a sterile opposition of conflicting

value positions. One member asserts the importance of democratic or egalitarian considerations; another asserts the importance of commercial considerations: in these terms there is very little to be said. Both considerations may be valid and there may (on occasions) be little option but to choose between more of one and less of the other. On the other hand, it may be possible to tackle the problem in a way which respects both concerns; the point is that the routine opposition of apparently conflicting principles does not seem to pose the problem in a way that is likely to bring out this possibility.

"Reframing" Co-operative Organisation

So far, it has been argued that the perfectly valid ideals people commonly hold for co-operatives create frames of reference in which it is actually rather difficult to consider what co-operative organisation might mean in the face of particular practical contingencies. Whether they are grounded in an ideal of a harmonious team, a political or moral community, or mutual protection, such frames of reference conceive a co-operative organisation in terms that are usually static, remote from actual practice and, if not irrelevant, appear often to hinder any dialogue on the issues. The question, then, is whether these difficulties can be avoided, without creating too many new ones. It is suggested that a rather different way of looking at co-operative emerges if one considers the ways in which co-operatives tackle the problems that have been described. The question is not whether, or to what extent the problems have been resolved, for this might imply another utterly remote ideal. Perfect consensus and clarity over objectives, an entirely unambiguous relationship between the two systems of control, a final working through of leadership dilemmas, self-organised group working and

the productive handling of all differences will never occur, if for no other reason than that circumstances and personnel are always changing. The question is how these problems are tackled; and in each case it is clear that processes of individual and organisational learning are required if confusion, cynicism, disillusion and frustration are not to be the principal result.

Individual and Organisational Learning as Ways of Coping with Organisational Problems

Thus, the problems concerning objectives may be attenuated by a progressively clearer appreciation on the part of members of their own differing concerns, of the position and negative impacts policies to promote particular objectives may have on other objectives and of the significance of environmental changes for the pattern of objectives pursued. Disagreements will not vanish simply as a result of "better understanding", of course, but agreement may be negotiated more easily - and carry greater acceptance. To the extent that the understanding of members increases in these respects, individual learning is taking place. But to the extent that the climate and procedures of a co-operative develop to enable continuous learning of this sort to take place, such that the co-operative's capacity to reconsider and change its objectives is strengthened, to this extent organisational learning can be said to have occurred.

Likewise, the problems concerning the two systems of control may be reduced in part by a greater understanding on the part of individuals of the issues involved. But these problems will be coped with more adequately if the understanding of individuals becomes embodied in decision-making practices and publicly shared and available appreciations of the underlying dilemmas. To the extent

that a co-operative's repertoire of responses to problems in this area and its effectiveness in dealing with them increases, organisational learning has occurred.

Similarly, to the extent that usually undiscussable problems of leadership become discussable, this represents an organisational change that allows some kind of inquiry into the problems to take place.

Finally, the individual and organisational learning involved in work reorganisation and the productive handling of conflict are obvious. In both cases, the individual learning requires a climate that supports experimentation and a degree of openness in the consideration of mistakes.

Again, to the extent that adaption and adjustments in ways of working are made more quickly and effectively (whether by those in management or shop floor positions) this represents more than individual learning; it is a development in the pattern of organisational relationships and practice towards greater responsiveness and discrimination. As such, it can be considered as organisational learning.

To avoid misunderstanding, two points should be made quite clear. First, though organisation learning can be set up as another (as yet unrealised) ideal²⁷ this is not the intention here. The aim is simply to suggest a more useful perspective for thinking about the organisation of co-operatives. Slowly and fitfully learning processes, as described, do occur in co-operatives. Whilst there will may be costs involved in encouraging these learning processes, there are also costs (sometimes massive) involved in organisational games, unproductive conflict, camouflage, disillusion distrust of initiatives, and so on.

Secondly, thinking about co-operative organisation in these terms does not mean discarding one's hopes and ideals. This perspective does not contradict those that were described earlier. In fact processes of individual and organisational learning are necessary if a co-operative is to explore any of the ideals described. To this extent it may make clearer the common ground between those with differing ideals. In practical terms, this amounts to the suggestion that instead of asking "how can the co-operative be (or was the co-operative) efficient/democratic/responsible/egalitarian in tackling this problem", it will be more productive to ask "what has the co-operative (or can the co-operative) learn, relevant to its varied and developing ideals and hopes, in tackling this problem".

Problems and Advantages of Learning as a Frame of Reference

In suggesting this framework for thinking about co-operative organisation there are numerous problems. What is learning for one person is ideological absorption for another. Moreover, the concept of organisational learning remains extremely difficult, with the literature either dubious or obscure (and quite often both). But it may be a fruitful minefield and there do seem to be two definite advantages, especially in the context of co-operatives.

First, there is a definite link between the idea of co-operation, implying a self-determining relationship between the participants, and the increasing understanding associated with learning processes. For a system to be self-determining involves an increasing awareness both of itself and its environment. As was hinted earlier, the ultimately self-determining nature of co-operatives often

tends to be overlooked by those with ideal-derived frames of reference, who discount co-operatives that they consider are not pursuing financial or democratic or moral or egalitarian objectives with sufficient zeal. Put simply it is as futile for a business consultant recommending proper business policies and decision-making procedures to discount members' aspirations, as it is for radicals, to recommending participative procedures, to ignore members' concerns for security and remuneration. Secondly, the idea of learning process ensures that one thinks about the organisation of co-operatives in dynamic terms. In fact, most co-operatives are continually modifying and experimenting with their participative procedures and to propose, for example, structures that must exist for proper co-operative organisation, simply ensures surprises, incomprehension and disappointment. Often, it is the processes that are constant while the structures change; and the only justification for proposing particular structures is in terms of the processes they may, for a time facilitate.

In summary, therefore, the suggestion that one should consider the scope for individual and organisational learning as central to the idea of co-operative organisation is a plea that those who write about, think about, promote or assess co-operatives should take seriously the idea of co-operatives as self-determining systems, and should think about the problems of co-operative organisation in dynamic, process terms. There are numerous theoretical difficulties in using such a frame of reference (this hardly makes it unique) but, in so far as it avoids some of the very definite problems of ideal-derived conceptions of "proper" co-operative organisation it has some definite advantages.

REFERENCES

- 1 Vanek, J (1970) "The General Theory of Labour Managed Market Economies". Ithaca N.Y., Cornell University Press. For his solution, see Vanek (1973) "Some Fundamental Considerations on Financing and the Form of Ownership".
- 2 Coates, K and Topham, T. "Industrial Democracy in Great Britain" (1968). Has some material on the rise and fall of the Guilds in the years after the First World War; Ben Jones "Co-operative Production" (1894) still remains the primary source on the producer co-operatives of the 1870's and 1880's; the co-operatives thrown up by the first stirrings of the labour movement in the 1820's and 1830's - before trade unions, consumer co-operatives and producer co-operatives were clearly differentiated strands within it - are also discussed.
- 3 Jones, D. ~~and~~ K.Coates, ed. "The New Worker Co-operatives" Spokesman 1976.
- 4 Miester, A. "Ou Va L'autogestion Yugoslave?" 1970.
- 5 Oakeshott, R. "Industrial Co-operatives : The Middle Way". Lloyds Bank Review, March 1978.
- 6 Oakeshott (ibid p55) discussing the role of the Caja Laboral Popular in the Mondragon Group of Co-operatives states "..... it ensures that the groups member enterprises follow the policies, rules and structural arrangements laid down in the contract of association which all the member enterprises must sign with it. This contract specifies the various rules - covering capital stakes, distribution of profits and losses, differential limits, and so on - with which the co-operative must comply. There is thus a built-in check against the risk that the sovereign workforce of a particular co-operative might choose to change its rules - and, for example, award itself an enormous wage increase. Under the contract of association, actions of that kind are ruled out. Of course, member co-operative is free to decide to negotiate a withdrawal from the contract and to disaffiliate from the group. But, in that case, it would be denying itself access to both the Caja's capital and its management services". Oakeshott (emphasis added) evidently sees no contradiction between these arrangements and "the full reality of democratic

control" (p56). Others are not so sanguine. For example, J. Eaton in "Mondragon's Teeth" (unpublished paper, Department of Economics, UCW Aberystwyth), whilst commending the arrangements as a "durable mechanism for accumulation and growth" (p6) reports "..... here, as in conventional capitalist companies, ownership is separate from control and the democratic control structures devised by the Caja Laboral Popular are ineffective. Every co-operative has a junta rectora or control board which is supposed to consult with and advise management on policy each month. To nobody's great surprise, day-to-day decision-making by the technocrats soon takes over; you cannot achieve commercial success managing by committee. As one worker whom we interviewed put it, "the co-operative is a good idea but as time passes it falls into the hands of the chairman and the management who, by having more information and resources than the junta rectora, can always make their opinion or point of view prevail".

All the usual mechanisms of managerial control of the workforce exist in the co-operatives and there is little room for improving the quality of working life. Scientific management and work measurement are adopted with alacrity. There are clock cards, work study and work measurement, job evaluation and detailed personnel records on absenteeism. The only exception to this are some limited experiments in job rotation and job enrichment at the bigger co-operatives such as Ulgor and Copreci" (p5).

- 7 Miester, Albert. "La Participation Dans Les Associations" 1974. Hadley R. "Workers' Self-Management in France". ICOM 1973.
- 8 Quoted in Paton, R. "Fairblow Dynamics Ltd : Participation and Common Ownership". Co-operatives Research Unit 1979.
- 9 Dunn, William N. "The Economics of Organisational Ideology". Journal of Comparative Administration 1974.

- 10 Lockett, M. "Action Research in Co-operatives Enterprises : Theory and Practice". Paper for Second International Conference on Participation Worker's Control and Self-Management, Paris, September 1977.
- 11 Paton, R. op. cit. p156.
- 12 Ibid.
- 13 Lockett, M. "Fakenham Enterprises". Co-operatives Research Unit 1978.
- 14 Lockett, M and Paton, R. "The Jewellery Co-operative" . Co-operatives Research Unit forthcoming 1979.
- 15 Tynan, E. "Constructive Co-operatives : Three Case Studies" Co-operatives Research Unit, forthcoming 1979.
- 16 Ibid.
- 17 Flanders Pomeranz and Woodward. "Experiment in Industrial Democracy" (1968). Hadley R. "Rowen, South Wales : Notes on an Experiment in Workers Self-Management" in Vanek ed. "Self-Management; the Economic Liberation of Man". Penguin 1975. Blum, F.H. "Work and Community The Scott Bader Commonwealth and the Quest for a New Social Order" RKP 1968; Kirkham, M. "Industrial Producer Co-operation in Great Britain". University of Sheffield 1973 (unpublished M.A. Thesis).
- 18 For example, the alternative corporate plan of the Lucas Aerospace Combine Shop Stewards Committee.
- 19 Paton, R. "Fairblow Dynamics" Part III Section 4.
- 20 Roger Sawtell, personal communication.
- 21 For example, Brower, M. "Experience with Self-Management and Participation in the United States" in G.D. Garson and M.P. Smith eds. "Organisational Democracy". Sage 1976.
- 22 Roger Hadley, personal communication.
- 23 Tynan, E. op. cit.

- 24 Lockett, M. "Worker Information Systems : Towards an Analysis". Co-operatives Research Unit discussion paper 1978.
- 25 Kirkham, M. op. cit.
- 26 Lockett, M. 1977 op. cit.
- 27 This seems to be the case in Argyris C., and Schon D., "Organisational Learning : A Theory in Action Perspective". Addison-Wesley (1978).

