

THREE-PARAMETER CREEP DAMAGE CONSTITUTIVE MODEL AND ITS APPLICATION IN HYDRAULIC TUNNELLING

Luo Gang¹, Chen Liang²

¹ School of Highway, Chang'an University, Xi'an, Shanxi, 710064; China; e-mail: Luogang@chd.edu.cn

² Guangxi Communications Investment Group Co, Nanning, Guangxi, China, 530029, e-mail: clng9716@163.com

ABSTRACT

Rock deformation is a time-dependent process, generally referred to as rheology. Especially for soft rock strata, design and construction of tunnel shall take full account of rheological properties of adjoining rocks. Based on classic three-parameter HK model (generalized Kelvin model), this paper proposes a three-parameter H-K damage model of which parameters attenuate with increase of equivalent strain, provides attenuation equation of model parameters in the first, second and third stage of creep deformation and introduces equivalent strain threshold value. When the equivalent strain is greater than the threshold value, the third stage of accelerating creep will be conducted. The three-parameter H-K damage model is used for numerical calculation of finite difference method FLAC^{3D} and deformation features of soft rock with time under high ground stress are described based on diversion tunnel project of Jinping Hydropower Station, of which model parameters can be obtained by back analysis according to measured site data and BP neural network.

KEYWORDS

Rheology; three-parameter H-K damage model; time-dependent deformation

1. INTRODUCTION

As shown from a large number of indoor tests and field tests, rock force deformation is a time-dependent process [1-3]. Especially for soft rock and loose rock mass with filling and fractured zone, the deformation possesses time effect. Elastic-plastic theory cannot describe and predict the process while rheological theory can better overcome this shortcoming. For force and deformation of cavern adjoining rocks in the tunnel and underground engineering, rheologic model shall be taken to reasonably interpret instability or even collapse during the construction of unsupported hole, deformation of adjoining rocks, continuously increased support structure deformation pressure ageing effect of lining and adjoining rock and other phenomena in the real-time engineering works [4-5].

Rheological properties of rocks become increasingly prominent in the construction of tunnel, slope and other fields. Especially under the condition of soft rock geology, long-term stability of engineering is closely related to rheological properties of rocks. Therefore, study

on rheological model of rock gets more attention. Through Kelvin, H-K, H | M and other viscoelastic models, classical linear elements (Hooke body) and viscous elements (Newtonian) provide preliminary understanding of rheological properties and identify them in a number of test results [6].

Many scholars proposed a modified rheological model based on test result to describe creep deformation of rocks, such as viscoelastic plastic damage model [7-8] providing an equation of rock strength parameters (c, ϕ) with the time. Constitutive relation of the viscoelastic plastic damage model is obtained based on standard thermal dissipation potential by the principle of strain and energy equivalence. Other scholars also conducted a study for this point [9-11]. The viscoelastic plastic damage model is proposed based on creep test results of rock specimen to reflect accelerating creep in the third stage, but it can be used to indicate more complex conditions now. Based on the three-parameter H-K damage model, this paper introduces the equation of model parameters attenuating with equivalent strain to propose a new modified H-K model and apply the model to numerical calculation of FLAC^{3D} and analyses creep deformation characteristics of soft rocks under high ground strain in the diversion tunnel engineering of Jinping II Hydropower Station.

2. THREE-PARAMETER H-K DAMAGE MODEL

2.1. Classic three-parameter H-K damage model

Classic three-parameter H-K damage model consists of elastomer and viscous body, as shown in Figure 1. G^E is shear modulus of elastic element; G^K and η^K are respectively shear modulus and viscosity factor of Kelvin body. Constitutive equation of the model is shown in (1), (2) and (3).

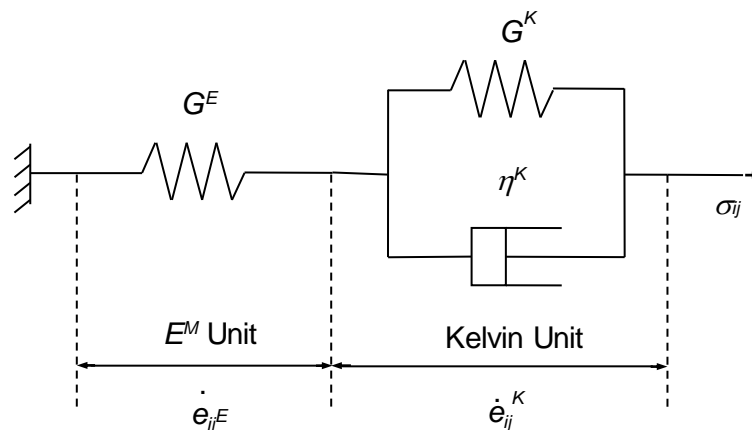

Fig. 1. - Classic Three-parameter H-K Damage Model

$$\dot{e}_{ij} = \dot{e}_{ij}^E + \dot{e}_{ij}^K \quad (1)$$

$$S_{ij} = 2\eta^K \dot{e}_{ij}^K + 2G^K e_{ij}^K \quad (2)$$

$$\dot{\epsilon}_{ij}^E = \frac{\dot{S}_{ij}}{2G^E} \quad (3)$$

In the above equation, ϵ_{ij} and S_{ij} are respectively deviatoric strain tensor and deviatoric stress tensor. Superscript E and K respectively indicate elastomer and Kelvin body. The three-parameter H-K model is a typical viscoelastic model without consideration of plastic deformation. It can better describe the first and second stage of creep deformation. With infinite time increase, the strain will tend to a stable value. But the model cannot reflect the third stage of accelerating creep.

2.2 Three-parameter H-K damage model

A number of rheological tests indicate the following characteristics of ϵ - t curve for rock creep deformation:

(1) Instantaneous application of stress σ will cause an instantaneous elastic deformation ($\epsilon_0 = \sigma/E$).

(2) When the stress level is lower than long-term intensity ($\sigma < \sigma_s$), strain growth rate gradually declines to 0. In case of $t \rightarrow \infty$, the strain will tend to a fixed value and materials will not have yield and damage but are only subject to the first stage (deceleration) and the second stage (stabilization) of creep.

(3) When the stress level is greater than or equal to long-term strength ($\sigma \geq \sigma_s$), the strain will increase infinitely with time and will not converge to a fixed value, materials will follow yield and destruction and the creep will enter the third stage (acceleration) after the first and second stage.

As shown from the above characteristics, creep deformation is generally divided into three stages. As shown in Figure 2, it is a nonlinear process. For relatively hard rocks, three-stage deformation is not significant. Especially when the material stress exceeds long-term strength, deformation time of the third-stage is short, that is, rocks are quickly destroyed; relatively soft rocks follow significant three-stage deformation characteristics. Three stages of creep deformation can be described by viscous elastic mechanics or visco-plasticity. When the viscous elastic mechanics is used for description without consideration of yield and plastic deformation, OA section is elastic deformation and AD section is three stages of creep deformation, as shown in Figure 2; when visco-plasticity is used for description with stress value greater than yield strength, OA section includes elastic deformation and plastic deformation. If the stress value fails to exceed the yield strength, the PA section will only include elastic deformation.

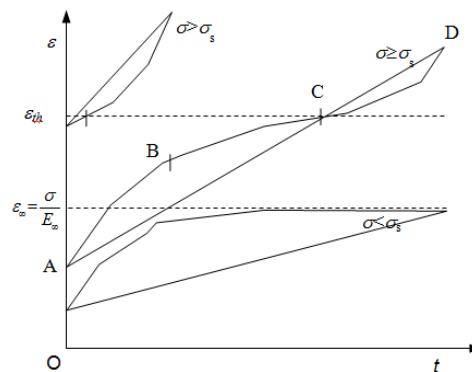

Fig. 2. - Creep Characteristic Curve of Three-parameter H-K Damage Model

According to the above characteristics, classic viscoelastic model can reflect elastic deformation and creep deformation in the first and second stages. For example, Burgers model and Xiyuan model can better indicate elastic deformation, decelerated creep and steady creep when the stress is greater than long-term strength. But they cannot describe accelerated creep deformation or indicate deformation convergence when the stress is smaller long-term strength. Three-parameter H-K (generalized Kelvin) viscoelastic model can properly indicate deformation convergence when the stress is smaller long-term strength, but it cannot describe characteristics of accelerated creep when the stress is greater than long-term strength.

Based on shortcomings of existing model, this paper proposes the three-parameter H-K damage model to introduce the damage equation of model parameters (G and η). In fact, relevant rheological test has proven that elastic modulus, compressive strength and other parameters of rocks attenuate with the time under a certain level of stress. When numerical calculation is conducted, it is difficult to determine the range of the rocks of which parameters attenuate with the time in the loading or unloading. Therefore, it is more appropriate that rock parameters attenuate with the strain and the strain itself is time-dependent in the creeping. If rock parameters attenuate due to strain, they will be also time-dependent. Therefore, attenuation of rock parameters under strain is defined as follows:

$$A_1(\varepsilon) = A_\infty + (A_0 - A_\infty)e^{-w_1(\varepsilon - \varepsilon_0)} = A_0 \left[k + (1 - k)e^{-w_1(\varepsilon - \varepsilon_0)} \right] \quad (\varepsilon < \varepsilon_{thr}) \quad (4)$$

$$A_2(\varepsilon) = A_1(\varepsilon_1) \left[2 - e^{w_2(\varepsilon - \varepsilon_1)} \right] \quad (\varepsilon \geq \varepsilon_{thr}) \quad (4)$$

Where, A indicates model parameter which can be shear modulus or coefficient of viscosity; $A_1(\varepsilon)$ indicates parameter change in the first and second stage of creep, $A_2(\varepsilon)$ indicates parameter change in three stages of creep, A_0 is an initial parameter value, A_∞ is a long-term parameter value, k is defined as attenuation ratio, namely $k = A_\infty / A_0$, ε_0 is the strain generated from elastic deformation, ε_1 is the strain in the first and second stage of creep, w_1 and w_2 are specific parameters and v is exponential quantity of ε .

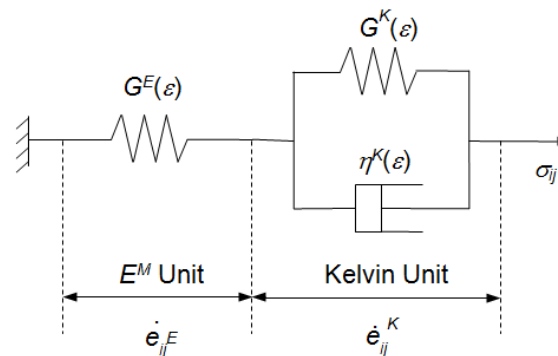

Fig. 3. - Three-parameter H-K Damage Model

As shown from the three parameters damage model H-K schematic shown in Figure 3, and the creep characteristic curve of three-parameter H-K damage model shown in Figure 2. strain threshold ε_{thr} , ε_{thr} is applied when it is equal to the strain generated during its long-term strength. When the strain exceeds the threshold, it will enter the third stage of accelerating creep, then the attenuation of rock parameters accelerates (formula (5)). To apply the equivalent strain ε_{eq} in the three-dimensional condition, namely, consider the six strain components into a linear stress. To substitute ε_{equ} by ε in formula (4) and (5), among which, the equivalent strain is as below:

$$\varepsilon_{equ} = \sqrt{\frac{2}{9}[(\varepsilon_1 - \varepsilon_2)^2 + (\varepsilon_2 - \varepsilon_3)^2 + (\varepsilon_3 - \varepsilon_1)^2]} = \sqrt{\frac{2}{3}(\varepsilon_1^2 + \varepsilon_2^2 + \varepsilon_3^2)} \quad (5)$$

Finite difference program FLAC3D did not give the principal strain, so it can be calculated by the following formula:

$$\varepsilon_{equ} = \frac{\sqrt{2}}{3} \sqrt{(\varepsilon_x - \varepsilon_y)^2 + (\varepsilon_y - \varepsilon_z)^2 + (\varepsilon_x - \varepsilon_z)^2 + 6(\gamma_{xy}^2 + \gamma_{xz}^2 + \gamma_{yz}^2)} \quad (6)$$

In the above formula, ε_1 、 ε_2 、 ε_3 refer to major principal strain, ε_x 、 ε_y 、 ε_z 、 γ_{xy} 、 γ_{xz} 、 γ_{yz} are the principal stress respectively.

In FLAC3D (Itasca Consulting Group, 1997), the calculation process parameters can be achieved through its built-in attenuation FISH language, each computing a time step (step or cycle), based on the equivalent strain increment model units and combined type (4) and (5) to calculate new creep parameters, then correct each unit cell parameters of the model until the calculated creep set time is reached. Stop the calculation when the parameters of accelerated decay to zero, which means it enters into the state of failure.

2.3 Example of three-parameter damage model

1/4 of tunnel dimension is taken as a calculation model with tunnel radius of 7m, horizontal coordinate range $x = 0$ to 60m, vertical coordinate range $z = 0$ to 60m and longitudinal coordinate range $y = 0$ to 1m. It can be divided into 1,556 nodes and 740 units. The model has restrictions imposed all round and takes initial ground stress σ_{zz} of 40MPa and lateral pressure coefficient of 1 to simulate deep tunnel. Calculation model and monitoring point arrangement are shown in Figure 4. For model parameters, see Table 1. The calculation shall not consider influence of support and volumetric strain, that is, the

calculation shall take volume modulus of 0, plane strain model and complete stress release without consideration of tunnel face influence.

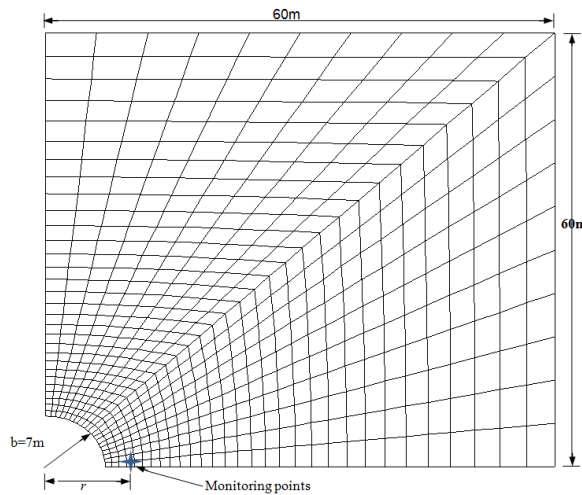

Fig. 4. Calculation Model

Tab 1. - Parameter Calculation

| $G^M(\text{MPa})$ | $G^K(\text{MPa})$ | $\eta^K(\text{MPa Day})$ | $\sigma_{zz}(\text{MPa})$ | λ |
|-------------------|-------------------|--------------------------|---------------------------|-----------|
| 3000 | 1000 | 20000 | 40 | 1 |

Attenuation of parameters in the first and second stage of creep deformation is calculated according to Formula (4) to get changing curve of tunnel side wall ($r=7\text{m}$) displacement with the time, as shown in Figure 5 and Figure 6. In case of $k=0$ and $w_1=0$, it is a viscoelastic solution of typical three-parameter model almost matched with results of analytic solution [12-13]; in case of $k=0.5$, it is a modified three-parameter viscoelastic damage model solution, indicating the displacement significantly grows with increase of w_1 value; in case of $w_1=50$, the displacement will quickly grow with reduction of k value and its growth rate will become larger when k value is smaller. According to the above calculation results, the calculation result considering damage (k and w_1 are not 0) is larger than that without consideration of damage under the condition of fixed model parameters.

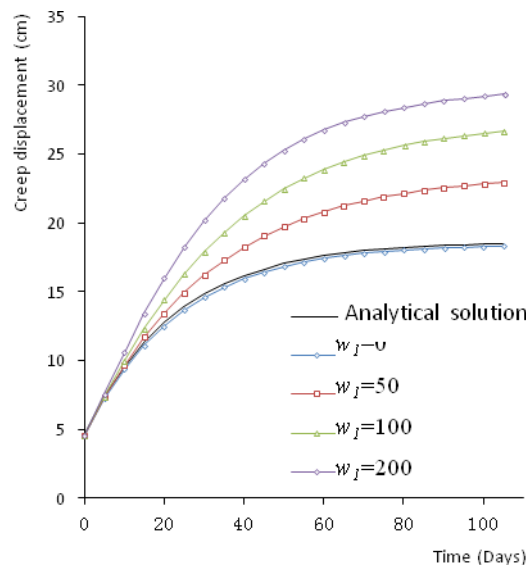

Fig. 5. - Calculation Result of Tunnel Side Wall Displacement ($r = 7m, k = 0.5$)

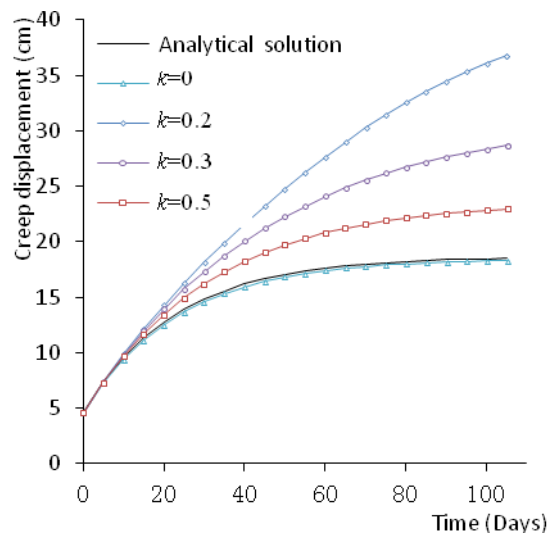

Fig. 6. - Calculation Result of Tunnel Side Wall Displacement ($r = 7m, w_I=50$)

According to the third stage of creep deformation calculation in formula (5), polt of side wall displacement is as shown in Figure 7. In the computing process, parameters acceleration could be judged by whether the equivalent strain of element (unit body) calculations exceeds the threshold ($\epsilon_{equ} > \epsilon_{thr}$). When creep into the third stage, the parameters w_2 and v influence the curves. As what could be seen from the figure, the smaller the w_2 , the faster the attenuation of parameters, which lead to obviously increased displacement.

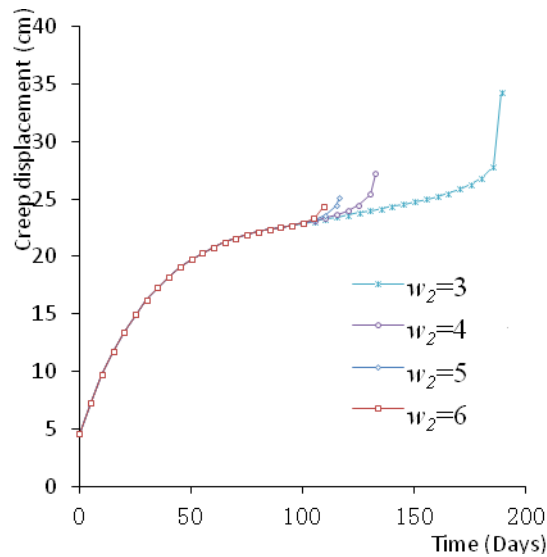

Fig. 7. - Calculation Result of Tunnel Side Wall Displacement ($r=7m$, $k=0.5$, $w_1=50$ and $\varepsilon_{thr}=0.038$)

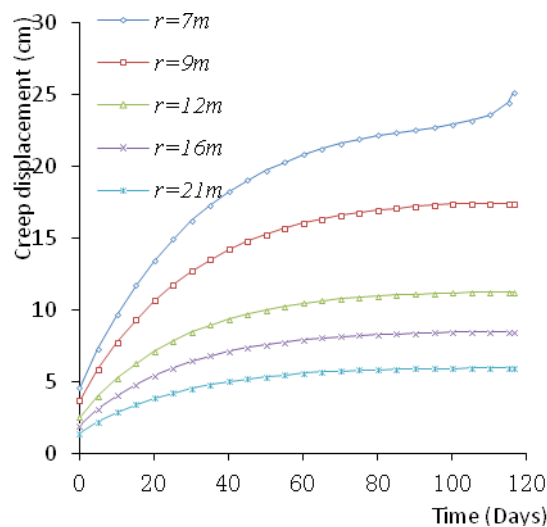

Fig. - 8. Calculation Result of Tunnel Side Wall Displacement

Figure 8 shows a different radial distance, changes of the adjoining rock displacement versus time, $r=7m$ shows the tunnel sidewall position, the elastic displacement of the apparent instantaneous maximum sidewall position, and through the three stages of creep deformation, first to destroy, indicating the stress suffered by a large rock in its long-term strength, strain over the threshold; whereas with increasing radial distance, instantaneous elastic displacement of rock decreases, and emerged with a timetable the first and second stages of creep deformation, indicating that rock is less than its long-term strength to withstand the stress and strain has not exceeded the threshold

3. RHEOLOGICAL ANALYSIS AND DISCUSSION

3.1 Divert tunnel of Jinping II Hydropower Station

Divert tunnel of Jinping II Hydropower Station was excavated to chlorite schist strata with a burial depth of about 1,500m in 2008. Under the influence of extreme-high geostress and low rock strength, the tunnel suffered large deformation and indicated time-dependent characteristics during the construction. Therefore, the three-parameter H-K damage model is used for describing and interpreting time-dependent deformation of the tunnel during the construction. Large deformation section of the diversion tunnel had the secondary excavation expansion in 2010. In this paper, rheological deformation of the tunnel before secondary excavation expansion is taken as the object of study.

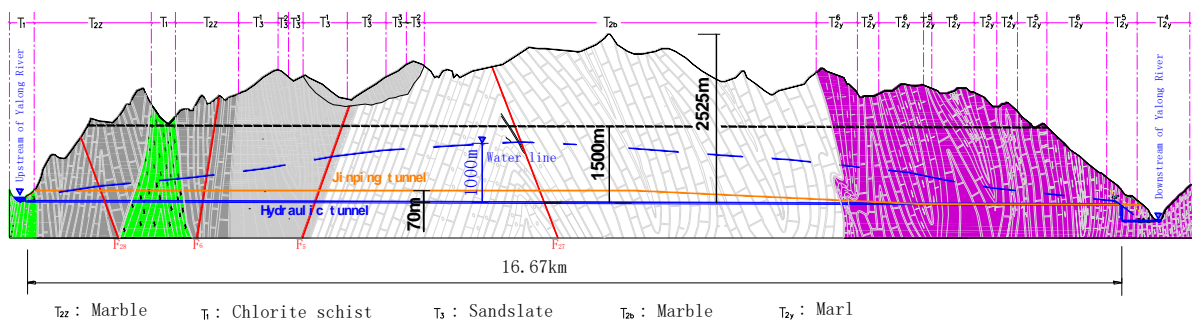

Fig. 9. - Geological Longitudinal Profile of Diversion Tunnel

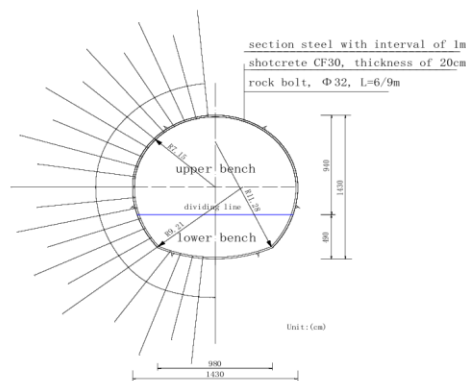

Fig. 10. - Cross Dimensions of Diversion Tunnel

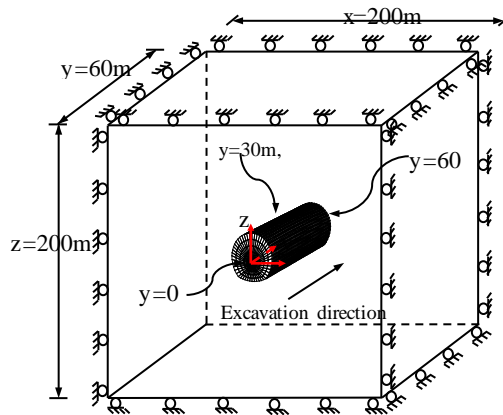

Fig. 11. - Model Boundary

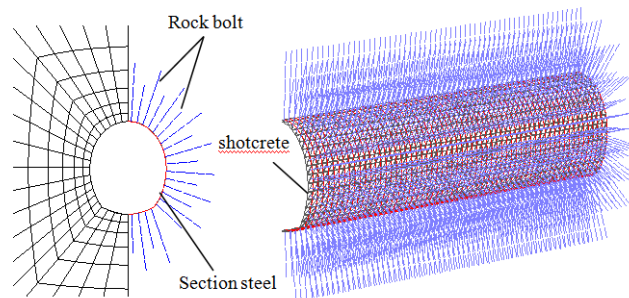

Fig. 12. - Support Model

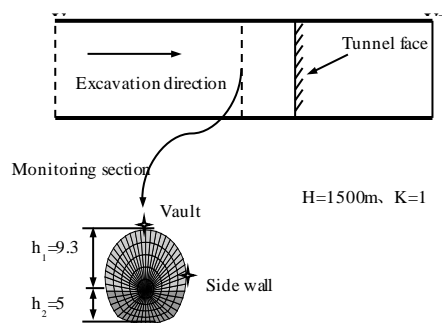

Fig. 13. - Monitoring Point Layout

Figure 9 demonstrates the geological section of water tunnel (Line1), Figure 10 indicates the fault plane dimensions, and computing model and monitors are arranged as shown from Figure 11 to 13. As the bench cut is adopted, and dig down the steps of the excavation was yet to be made before secondary evacuation, so the roof arch and side wall are set as the watch points. The depth of Analog excavation is 1m. To apply support including rock bolt, Steel arch and pneumatically placed concrete right after evacuation, and to simulate steel arch by beam elements, and to simulate pneumatically placed concrete by shell element, and to simulate rock bolt by cable element. Parameters of supporting structure and adjoining rocks are shown as Tables 2 and 3 as below.

Tab. 2. - Simulation Parameters of Support Structure

| H20 Profile Steel | | System Anchor Bolt | | CF30 Shotcrete | |
|--|-------|---|--------|------------------------------------|-------|
| Elasticity modulus $E(\text{GPa})$ | 200 | Elasticity modulus $E(\text{GPa})$ | 200 | Elasticity modulus $e(\text{GPa})$ | 21.44 |
| Poisson's ratio μ | 0.29 | Cross-sectional area $A(\text{cm}^2)$ | 8.042 | Density $P(\text{kg/m}^3)$ | 2500 |
| Cross sectional area $A(\text{cm}^2)$ | 64.28 | Tensile strength $F_t(\text{KN})$ | 241.3 | Poisson's ratio μ | 0.2 |
| Moment of inertia $I_y(\text{cm}^4)$ | 1600 | Anchoring agent cohesion $C_g(\text{KN/m})$ | 200 | Thickness $t(\text{cm})$ | 20 |
| Moment of inertia $I_z(\text{cm}^4)$ | 4770 | Anchoring agent stiffness $k_g(\text{MPa/m})$ | 17.5 | | |
| Polar moment of inertia $J(\text{cm}^4)$ | 6370 | Anchoring agent outer perimeter (m) | 0.1507 | | |

Tab. 3. - Parameters of adjoining rock

| $\rho(\text{kg/m}^3)$ | $K(\text{MPa})$ | $G^M(\text{MPa})$ | $G^K(\text{MPa})$ | $\eta^K(\text{MPa Day})$ | k | w_1 |
|-----------------------|-----------------|-------------------|-------------------|--------------------------|-----|-------|
| 2610 | 6000 | 1500 | N/A | N/A | N/A | N/A |

Note: adjoining rock failure is not considered and no value is assigned for w_2 , v and ε_{thr}

3.2 Rheological deformation characteristics

An analogue calculation is conducted for different deformation sections of K1+675, K1+760 and K2+665. Calculation results are only used for selecting time-dependent deformation. Calculated value is compared with measured data, as shown in Figure14 to Figure16. Curves in the figures show compliance of calculated value with measured data, indicating the three-parameter damage model has high adaptability. Model parameters are determined by the artificial neural network back analysis [14]. For lack of the space, specific methods are not detailed in the paper. GK, K, k and w_1 are parameters to be determined. To ensure balanced distribution of training samples, form design method can be used for the back analysis [15] to design normal analysis test plan. According to uniform design table of U30(304), design test combination, four factor levels and 30 sets of test data; particle swarm optimization method can be taken before BP network training to optimize initial weights and thresholds of BP network in order to improve network training effect. Creep parameters are obtained based on BP network back analysis, as shown in Table 4.

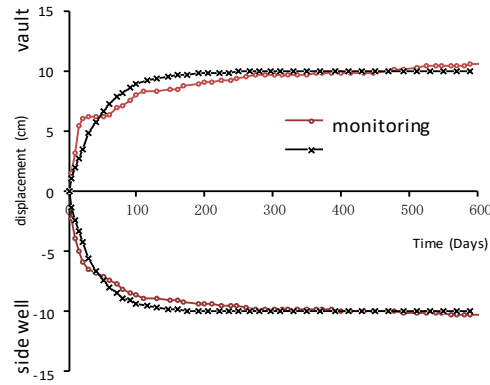

Fig. 14. - Comparison between Measured Data and Calculated Value (K1+675)

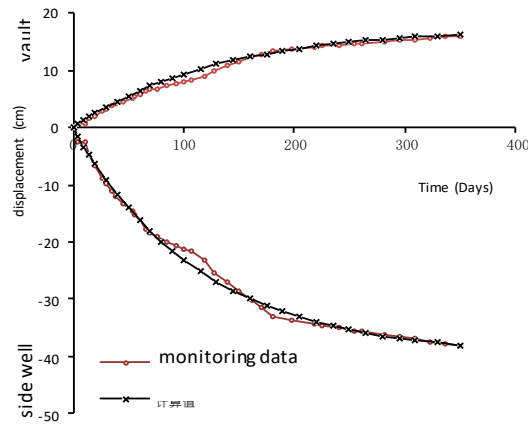

Fig. 15. - Comparison between Measured Data and Calculated Value (K1+760)

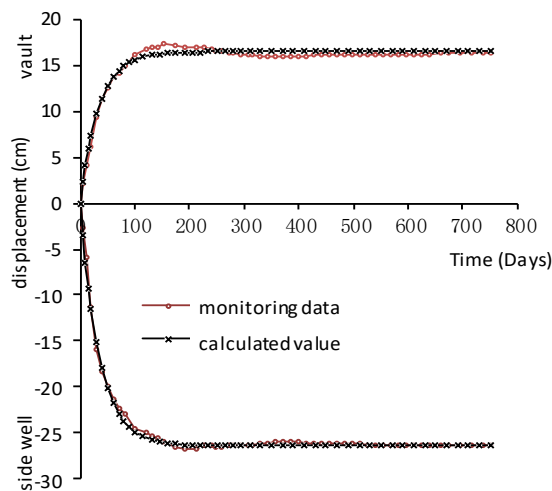

Fig. 16. - Comparison between Measured Data and Calculated Value (K2+665)

Tab. 4. - Model Parameters

| location | G^k (MPa) | η^k (MPa Day) | k | w_1 |
|----------|-------------|-----------------------|------|-------|
| K1+675 | 1426 | 52083 | 0.12 | 2.93 |
| K1+760 | 575 | 72337 | 0.30 | 4.15 |
| K2+665 | 691 | 23726 | 0.36 | 5.37 |

4. CONCLUSION

According to classic three-parameter H-K damage model (generalized Kelvin model), it will be difficult to determine unit range of model parameter attenuation in the large-scale numerical calculation if model parameters are set to tem-dependent attenuation. Therefore, this paper proposes a three-parameter damage model subject to model parameter attenuating with strain increase and gives an attenuation equation respectively for parameters in the first, second and third stage of creep deformation. In addition, strain threshold ε_{thr} is introduced. ε_{thr} is the strain generated when the rock stress is equal to long-term strength. When the rock strain is smaller than the threshold, only the first and second stage of creep deformation will occur. When the rock strain is larger than the threshold, the accelerated creep deformation will occur. Influences of attenuation parameters k , w_1 , w_2 and v on the creep deformation are respectively discussed in the example. The three-parameter H-K damage model is used for numerical calculation of finite difference method.

FLAC3D and deformation features of soft rock with time under high ground stress are described based on diversion tunnel project of Jinping Hydropower Station. It shows high compliance of calculated value with measured data, indicating the three-parameter damage model has high adaptability. Model parameters are obtained by back analysis based on measured data and BP neural network. The model proposed in this paper can properly describe three stages of soft rock creep deformation, reasonably interpret large deformation of soft rocks and predict the large deformation to some extent.

REFERENCES

- [1] Yang, C.H., Daemen, J.J., Yin, J.H., 1999. Experimental investigation of creep behavior of salt rock. *International Journal of Rock Mechanics and Mining Sciences*. 36(3), 233-242.
- [2] Li, Y.S., Xia, C.C., 2000. Time-dependent tests on intact rocks in uniaxial compression. *International Journal of Rock Mechanics and Mining Sciences & Geomechanics Abstracts*. 37(3), 467-475.
- [3] Enrico, M., Tsutomu, Y., 2001. A non-associated viscoplastic model for the behaviour of granite in triaxial Compression. *Mechanics of Materials*. 33(5), 283-293.
- [4] Shalabi, F.I., 2004. FE analysis of time-dependent behavior of tunneling in squeezing ground using two different creep models. *Tunnel. Underground Space Technol.* 20, 271-279.
- [5] Tsai, L.S., Hsieh, Y.M., Weng, M.C., Huang, T.H., Jeng, F.S., 2008. Time-dependent deformation behaviors of weak sandstones. *Int. J. Rock Mech. Mining Sci.* 45, 144-154.
- [6] Sun, J., 1999. *Rheological behavior of geomaterials and its engineering application*. Beijing: China Architecture and Building Press.

- [7] Itasca Consulting Group, 1997. *FLAC3D, Fast Lagrange Analysis of Continua in 3 Dimensions, Version 3.0, User Manual*. Minneapolis.
- [8] Guan, Z.C., Jiang, Y.J., Yoshihiko, T., Huang, H.W., 2007. A new rheological model and its application in mountain tunnelling. *Tunnelling and Underground Space Technology*. 23(3), 292-299.
- [9] Pellet, F., Hajdu, A., Deleruyelle, F., Besnus, F., [10] 2005. A viscoplastic model including anisotropic damage for the time dependent behaviour of rock. *Int. J. Numer. Anal. Meth. Geomech.* 29 (9), 941–970.
- [10] Shao, J., Chau, K., Feng, X., 2006. Modeling of anisotropic damage and creep deformation in brittle rocks. *Int. J. Rock Mech. Min. Sci.* 43 (4), 582–592.
- [11] Bhandari, A., Inoue, J., 2005. Continuum damage mechanics for hysteresis and fatigue of quasi-brittle materials and structures. *Int. J. Numer. Anal. Meth. Geomech.* 29 (11), 1087–1107.
- [12] Goodman, R.E., 1989. *Introduction to Rock Mechanics*, second ed. Wiley, New York.
- [13] Ahmad, F., Farshad, M.T., Ahmadreza, H., Arash, V., 2010. Analytical solution for the excavation of circular tunnels in a visco-elastic Burger's material under hydrostatic stress field. *Tunnelling and Underground Space Technology*. 25(4), 297-304.
- [14] Guan, Z.C., Jiang, Y.J., Yoshihiko, T., 2008. Rheological parameter estimation for the prediction of long-term deformations in conventional tunneling. *Tunnelling and Underground Space Technology*. 24(3), 250-259.
- [15] Fang, K.T, Ma, C.X, 2001. *Orthogonal design and uniform design*. Beijing: Science Press.