



University of HUDDERSFIELD

University of Huddersfield Repository

Alaiwi, A, Sibley, Martin J.N., Mather, Peter and Holmes, Violeta

Extremely low frequency based communication link

Original Citation

Alaiwi, A, Sibley, Martin J.N., Mather, Peter and Holmes, Violeta (2009) Extremely low frequency based communication link. In: Proceedings of Computing and Engineering Annual Researchers' Conference 2009: CEARC'09. University of Huddersfield, Huddersfield, pp. 105-110. ISBN 9781862180857

This version is available at <http://eprints.hud.ac.uk/6870/>

The University Repository is a digital collection of the research output of the University, available on Open Access. Copyright and Moral Rights for the items on this site are retained by the individual author and/or other copyright owners. Users may access full items free of charge; copies of full text items generally can be reproduced, displayed or performed and given to third parties in any format or medium for personal research or study, educational or not-for-profit purposes without prior permission or charge, provided:

- The authors, title and full bibliographic details is credited in any copy;
- A hyperlink and/or URL is included for the original metadata page; and
- The content is not changed in any way.

For more information, including our policy and submission procedure, please contact the Repository Team at: E.mailbox@hud.ac.uk.

<http://eprints.hud.ac.uk/>

EXTREMELY LOW FREQUENCY BASED COMMUNICATION LINK

A. Alaiwi¹, M. Sibley¹, P. Mather¹ And V. Holmes¹

¹ University of Huddersfield, Queensgate, Huddersfield HD1 3DH, UK

ABSTRACT

The paper discusses the literature review and the possibility of using the ground itself as transmission medium for various users' transceivers and an administrator transceiver using Multi-Carrier-Direct Sequence Code Division Multiple Access (MC-DS-CDMA), Orthogonal Frequency Division Multiplexing (OFDM), 16-Quadrature Amplitude Modulation (16-QAM), Frequency Division Duplex (FDD) and Extremely Low Frequency (ELF) band for the applications of Oil Well Telemetry, remote control of power substations or any system that its responding time is not critical.

Keywords Extremely Low Frequency, Multi-Carrier Code Division Multiple Access, Multi-Carrier Direct Sequence Code Division Multiple Access, Orthogonal Frequency Division Multiplexing, Frequency Division Duplex

1 INTRODUCTION

ELF is the band of frequencies from 0 to 300 Hz and is allocated by the Federal Communications Commission (FCC) for general purposes as free of charge. The idea of using the ground as transmission medium goes back to the beginning of 20th century when Mr. Nathan Stubblefield used it to transmit the human voice through the ground itself. In addition, the United States (U.S.) and Russian navies use ELF frequencies to communicate with their submerged submarines operating at frequencies lower than 100 Hz. The advantage of using ELF in communications comparing to higher frequencies is that ELF is able to propagate for long distances at low power without regeneration.

2 LITERATURE REVIEW

The literature review shows the history of using the ELF band and the ground itself as transmission medium. It also discusses the possibility of using multi-carrier modulation techniques for multiple access, and enhancing the transmission rate at very low frequencies.

2.1 TRANSMISSION MEDIUM

The farmer Mr. Nathan Beverly Stubblefield (1860-1928) was the first person to broadcast the human voice using his telephone system based on metal rods buried in the earth. In 1900 and on New Year's Day of 1902, Stubblefield and his son demonstrated this system to people in Kentucky-USA. In March 1902, he successfully demonstrated to scientists and other people how easily he could communicate from ship to shore using wires dropped from the stern of ship and the receiver on the shore connected to ground via an earth rod. This experiment was performed near the Potomac River-USA. Stubblefield experienced problems when he tried his system in Manhattan Island-USA because the soil was rocky and there was a bad Signal-to-Noise-Ratio (SNR) caused by 60 Hz of the power cables. In 1992, Bob Lochte a Professor in the Department of Journalism and Mass Communication at Murray State University, and Larry Albert a TV Engineer with a historical research replicated Stubblefield's system and successfully demonstrated it. This confirmed that Nathan B. Stubblefield used the ELF and VLF band (0 up to 3 KHz) to transmit the human voice through the ground [1-3].

2.2 EXTREMELY LOW FREQUENCY

ELF is mostly used by the navies. The U.S. Navy found that ELF signals penetrate sea water easier than higher frequencies – the lower the frequency being transmitted the deeper it penetrates. The U.S. Navy radiate the ELF waves using large transmitter facilities and use the lower part of the ionosphere layer and the earth's surface as an electromagnetic waveguide. Part of these waves pass into the ocean allowing communication with submerged submarines. Biological and ecological impact studies of ELF on humans and plants were conducted by the National Research Council-USA and the American Institute of Biological

Science. The conclusion was that there are no serious adverse effects of using the ELF band. It is expected that any communication system using the ELF band will suffer from noise caused by the electric feed cables, electric leakage through the earth rods and the lightning strikes that make the electrons in the atmosphere to oscillate between the ionosphere and surface [4-12].

2.3 SINGLE- AND MULTI-CARRIER SYSTEMS

A high spectral efficiency spectrum, maximising the number of users and transmission rate within a frequency band are the most critical design objectives and challenge to improve the reliability and performance of wireless communications systems. Multipath channels degrade the performance of the single carrier modulation technique and most of the conventional modulation techniques are sensitive to Intersymbol Interference (ISI) unless the channel symbol rate is small compared to the delay spread of the channel in the multipath environment [13-14, 16-19].

2.3.1 ORTHOGONAL FREQUENCY DIVISION MULTIPLEXING (OFDM)

OFDM offers high spectral efficiency due to the large number of sub-carriers that form a nearly rectangular frequency spectrum. It can be easily realized using Fast Fourier Transform (FFT) techniques. A guard interval (GI) is used in OFDM symbol to reduce the complexity of receiver and avoid ISI and Intercarrier Interference (ICI). But OFDM suffers from high Peak-to-Average-Power-Ratio (PAPR) that requires highly linear amplifiers otherwise the out-of-band power will be enhanced. Coded OFDM (COFDM) is the same as OFDM except that Forward Error Correction (FEC) is applied to the signal before transmission to avoid bit errors on subcarriers in deep fade so that the number of subcarriers needed is larger than the number of bits or symbols transmitted simultaneously. This is an advantage at high frequency transmission links such as the Digital Audio Broadcasting (DAB), Digital Video Broadcasting (DVB) and Digital Video Broadcasting – Terrestrial (DVB-T) systems used in Europe [13-20].

2.3.2 SINGLE-CARRIER SPREAD SPECTRUM SYSTEMS

Nowadays, the spread spectrum technique is a rapidly growing technology and widely used in wireless communications to allow multiple access simultaneously and privacy within the same channel, whereas OFDM itself does not. DS-SS and Frequency Hopping (FH)-SS are the primary types of spread spectrum. The DS-SS spreads a narrowband channel over a continuous bandwidth by mixing the data with Pseudo-random Noise (PN) code whereas the narrowband signal in the FH-SS is hopping over wide bandwidth using the PN code instead of spreading the signals over a continuous bandwidth. The DS-SS is preferred over FH-SS for long transmission distance due to the interference and multipath signals of the other systems. The DS-SS requires accurate power control so that no user masks all the users if its power is too high comparing to the other users at the receiver side. The DS-SS offers easy frequency planning, high immunity against interference if a high processing gain is used, flexible data rate adaptation and multiple access. Multiple access interference (MAI) occurs as the number of simultaneously active users increases in which the Single-Carrier (SC)-SS limited the number of users according to the processing gain [16-17].

2.3.3 MULTI-CARRIER SPREAD SPECTRUM SYSTEMS

The combination of OFDM and SS offers a robust system that is immune to multipath waves, reduces the ISI and ICI, allows multiple access and privacy. This combination is known as Multi-Carrier (MC)-SS that usually uses Walsh Hadamard orthogonal code. MC-SS is similar to the DS-SS except that the MC-SS performs the spreading code in the frequency domain. MC-SS can achieve good BER for N users using standard receiver techniques comparing to SC-DS-SS that requires highly complex receiver for the same N users. MC-SS better than COFDM in term of multiple access and also it replaces the encoder of COFDM by an NxN matrix to avoid bit errors [13, 16, 20].

MC-DS-SS is a descendent of MC-SS in which users are allowed to share the same bandwidth at the same time using PN code to separate the data of users. The main difference is that the MC-SS applies the PN code in the frequency domain whereas the MC-DS-SS applies it in the time domain as shown in figure (5). However, MC-SS can be realized using low complex OFDM operation and offers a flexible system design as the spreading code does not have to be equal to the number or sub-carriers. The MC-DS-SS can be realized with or without OFDM in which depends on the number of sub-carriers used as large number sub-carriers can be efficiently realized using OFDM [16].

3 METHODOLOGY

Stubblefield managed to transmit the human voice through the ground. The frequency components of the human voice extend from 20 Hz to about 3 kHz [26], varying in frequency and amplitude. However, the human voice includes the ELF band and it is advantageous to adopt this band in a communication link based on multicarrier system such MC-DS-CDMA. Using MC-DS-CDMA with help of OFDM and QAM to transmit the data in parallel form would enhance the transmission rate at such low frequencies; reduce the multi-path interference and maintain multiple access [21]. Transceivers are to be designed using FDD form to allow 2 ways of transmission simultaneously especially for the remote control applications. Field-Programmable Gate Array (FPGA) and Digital Signal Processing (DSP) chips are to be used to design, simulate, build and test the transceivers in laboratory. After that, the propagation characteristics of the transmission medium are to be tested, measured and classified by driving metal spikes into the ground and compared to the prototyped design shown in figure (1). Thereafter, the transmission distance is to be measured and repeaters can be used to regenerate the signal for long transmission distance.

4 EXPERIMENTAL APPARATUS, RESULTS AND DISCUSSIONS

The transceiver design involves the use of Phase Shift Key (PSK) modulation technique. The bandwidth of Binary (B)PSK technique is twice the bit rate ($2R_b$) whereas Quadrature (Q)PSK requires R_b only [21].

QAM is an advanced technique that combines the QPSK and Amplitude Modulation (AM) forms. For example, a 16-QAM can be modulated using In-phase and Quadrature signal where the Quadrature is to be used as a reference (threshold) to a single bit that is Amplitude Modulated on the In-phase signal. However, 3 bits (b_n, c_n, d_n) occupy 8 states on the carrier phase. Initially, they are to be modulated on the phase of 0° and once the phase is shifted to 45° , the data states will be changed to ($b_{n+1}, c_{n+1}, d_{n+1}$) at the same time there is a single bit (a_n) of the data is to be modulated on the Amplitude and it can be seen in figure (2) that the Quadrature is shifted with the In-phase by 45° to be 135° . The transceiver compares the absolute value of the In-phase and Quadrature to decide a logic [1] is received when the Quadrature value is greater than the In-phase value or otherwise no changes occur to (a_n). 16-QAM enhances the transmission rate of the

QPSK twice while occupying a bandwidth of less than that of the QPSK to be $\frac{3R_b}{4}$ [18, 19, 21].

The ELF limits the transmission rate according to lowest frequency in the channel. This minimum frequency should carry at least 4 cycles to represent a single bit in order to reach the receiver in good power. For instance, a single carrier of 20 Hz is capable of sending 5 bps using BPSK, 10 bps using QPSK and 20 bps using 16-QAM. So, using a multi-carrier system will limit the number of sub-carriers in the single channel. However, if the minimum frequency used is 20 Hz and the maximum frequency is 280 Hz there will be a large delay caused by the large number of cycles per bit that may shut down the receiver. Therefore, allocating many channels within the ELF band is the best way to examine the propagation characteristics of the ELF band and users can share the bandwidth. With the aid of a spectrum analyzer, the frequency components of the ground itself were obtained using the earthing system of the laboratory. It was found that there were odd harmonics of 50 Hz and integer harmonics of 60 Hz that will affect the data link. Therefore, 9 channels can be allocated as shown in figure (4) in order to meet these conditions and avoid problems of large delay, and each channel is divided into two halves so that the users access the admin receiver via the first half and the admin access the users' receiver via the second half using FDD. In addition, the use of MC-DS-CDMA will help combat the presence of 50 Hz noise.

The calculation of any physical size of useable antenna is based on the wavelength [27]. For instance, 20 Hz

requires: $\lambda = \frac{C}{f} = \frac{300 \times 10^6 \text{ m.S}^{-1}}{20 \text{ Hz}}$ $Antenna_size = \frac{15,000 \text{ Km}}{2} = 7500 \text{ Km}$. This is bigger than the

radius of the earth planet and confirms that Stubblefield managed to transmit the human voice using induction between the two earth rods. Therefore, a high conductive aluminium round solid bar, round tube and plate are used to design the antenna desired to link the transceivers. The designed antenna shown in figure (1) will reference the signals to the ground via the round tube and send the signals from one plate to the other. A prototype design in parallel with real environment is envisioned to consist of 2 boxes to contain the plates covered by sand as shown in figure (1) and a piece of pipe connecting the boxes together. In this case, various simulations can be applied like raising the conductivity using water, clay, etc. In addition, the pipe connecting the boxes can be surrounded by electrical cables in order to simulate the noise of the feed cables buried below the level of the ground.

The solid round bar passing through the round tube shown in figure (1) forms a capacitor that may attenuate the signals or form a short circuit but at the same time reference the signals into the ground. The capacitance and reactance calculations of this formation is

$$\text{The capacitance of this form is } C = \frac{2\pi\epsilon_0\epsilon_r}{\ln\left(\frac{b}{a}\right)} = \frac{2 \times \pi \times 8.854 \times 10^{-12} \times 5}{\ln\left(\frac{23.77 \times 10^{-2}}{6.35 \times 10^{-3}}\right)} = 42.2 \text{ pF.m}^{-1}$$

$$\text{Reactance at the lowest frequency } X_c = \frac{1}{2 \times \pi \times 20\text{Hz} \times 42.2 \text{ pF} \times 0.5\text{m}} = 377.8\text{M}\Omega$$

$$\text{Reactance at the highest frequency } X_c = \frac{1}{2 \times \pi \times 300\text{Hz} \times 42.2 \text{ pF} \times 0.5\text{m}} = 25.1\text{M}\Omega$$

These figures clarify that referencing the signals to the ground using this form will not attenuate the signals.

Noise is a major problem when transmitting/receiving data through wireless channels. Shot noise is generated by the random flow of charge carriers in semiconductors and thermal noise occurs in resistive components due to the thermal agitation of electrons in resistors. Another type of noise called flicker (pink or 1/f) noise is expected to affect the ELF link at such low frequencies. Flicker noise usually occurs in Metal-Oxide Semiconductor Field-Effect Transistor (MOSFET) systems but Junction Field-Effect Transistor (JFET) and Bipolar systems have less 1/f noise than the MOSFET. It is envisaged that JFET systems will be used to keep the 1/f noise low [22-25].

5 FURTHER WORK

The priorities for the future work involves the design and simulation of ELF Data Transmission link discussed in this paper based on MC-DS-CDMA, OFDM, 16-QAM and FFT using MATLAB that provide powerful functions like QAM, Raised-Cosine Filter, Square-Root-Raised-Cosine filter, coding techniques, channels, graphical representations, etc. After that, the MATLAB codes are to be converted to Very High Speed Integrated Circuit Hardware Description Language (VHDL) code using ModelSim and DSP Builder provided by Quartus II-Altera in order to download it on Cyclone II FPGA [28]. Burying the antenna designed and the noise is to be discussed for better SNR. Repeaters may be used later to test the transmission distances.

6 CONCLUSION

The possibility of using a communication link over the ELF band has been discussed for multiple access using the literature review based on the history of using the ground as transmission medium, ELF for telecommunications purposes and multi-carrier communications systems. Many problems associated with the receiver were discussed and solutions envisioned to use MC-DS-CDMA to operate the ELF Data Transmission Link.

REFERENCES

- [1] Lochte, B. (2001). KENTUCK FARMER INVENTS WIRELESS TELEPHONE! But Was It Radio? FACTS AND FOLKLORE ABOUT NATHAN STUBBLEFIELD. Printed by Innovative Printing and Graphics, Murray KY.
- [2] HOFFER, T. (1972) 'NATHAN B. STUBBLEFIELD AND HIS WIRELESS' JOURNAL OF BROADCASTING AND ELECTRONIC MEDIA, 15 (3) pp. 317-327
- [3] CLIFFORD, M. (1985) 'THE EARLY DAYS OF RADIO' RADIO ELECTRONICS, 57, (11) pp: 60-62
- [4] Extremely Low Frequency Transmitter Site: Clam Lake, Wisconsin, US Navy Fact File, June 28, 2001 [Online]. Available at: < http://www.fas.org/nuke/guide/usa/c3i/fs_clam_lake_elf2003.pdf > [Accessed 30th AUG 2009].
- [5] Aldridge, B. (February 2001). ELF HISTORY: EXTREME LOW FREQUENCY COMMUNICATION [Online] by Pacific Life Research Centre-United States. Available at: < <http://www.plrc.org/docs/941005B.pdf> > [Accessed 4th September 2008]
- [6] National Research Council Staff. (1997) Evaluation of the U. S. Navy's Extremely-Low-Frequency Submarine Communications Ecological Monitoring Program.

- Washington, DC, USA: National Academies Press, 1997. p 13.
< <http://site.ebrary.com/lib/uoh/Doc?id=10055127&ppg=27> > [Accessed 27th March 2008]
- [7] Pike, J. (2004) Extremely Low Frequency Communications Program [Online]. Available at: < <http://www.fas.org/nuke/guide/usa/c3i/elf.htm> > [Accessed on 21st Mar 2008]
- [8] Preve, C. (2006) Protection of Electrical Networks. ISTE: Printed and bounded in Great Britain by Antony Rowe Ltd, Chippenham, Wiltshire. Pp 53-54.
- [9] Rigby, B. (2005) Design of Electrical Services for Buildings. 4th Ed. Spon Press: Printed and bounded in Great Britain by TJ International Ltd, Padstow, Cornwall. Pp 137-139.
- [10] Frater, M. and Ryan, M.J. (2003) Communications and Information Systems. Argos Press. Pp 18-19.
- [11] Sueker, Keith H. (2005) Power Electronics Design A Practitioner's Guide. Newnes: Printed in United States of America. Pp 221-222.
- [12] Betz, H.D., Schumann, U. & Laroche, P. (2008) Lightning: Principles, Instruments and Applications: Review of Modern Lightning Research. Springer Netherlands. Pp 347-378.
- [13] Linnartz, Professor Jean-Paul. (2006) OFDM and MC-CDMA [Online] Available at: <<http://ofdm.linnartz.net>> [Accessed 12th September 2009]
- [14] Hanzo, L., Munster, M., Choi, B.J. & Keller, T. (2003) OFDM and MC-CDMA for Broadband Multi-User Communications, WLANs, and Broadcasting. England: John Wiley. Pp. 7-9.
- [15] Lawrey, E. (1997) The suitability of OFDM as a modulation technique for wireless telecommunications, with a CDMA comparison. PhD thesis, University of James Cook- Australia. Pp. 29-32
- [16] Fazel, K. & Kaiser, S. (2008) Fundamentals In: Multi-Carrier and Spread Spectrum Systems: From OFDM and MC-CDMA to LTE and WiMAX. 2nd Ed. West Sussex: John Wiley.
- [17] Esmailzadeh, R. (2006) Broadband Wireless Communications Business: An Introduction to the Costs and Benefits of New Technologies. West Sussex: John Wiley.
- [18] Qatawneh, I.A.Z. (1997) Introduction to OFDM. In: THE USE OF ORTHOGONAL FREQUENCY DIVISION MULTIPLEX (OFDM) TECHNIQUES IN MOBILE BROADBAND APPLICATIONS. PhD thesis, University of Huddersfield-UK. Pp. 1-11
- [19] Hurst, J.A. (2000) Introduction. In: AN INVESTIGATION INTO METHODS FOR THE CORRECTION OF FREQUENCY OFFSET IN OFDM SYSTEMS. PhD thesis, University of Huddersfield-UK. Pp. 1-4
- [20] Nassar, C.R., Natarajan, B., Wu, Z., Wiegandt, D., Zekavat, S.A. & Shattil, S. (2001) Overview of Multi-Carrier Technologies. In: Multi-Carrier Technologies for Wireless Communication. Hingham, MA, USA: Kluwer Academic Publishers. Pp. 5-38
- [21] Prasad, R. (1996) CDMA FOR WIRELESS PERSONAL COMMUNICATIONS. Artech House Publishers.
- [22] Horowitz, P. and Hill, W. (1994) THE ART OF ELECTRONICS. 2nd ed. Printed in USA 1994, Cambridge University Press. Pp.267-281 & P.p.222.
- [23] Storey, N. (1998). Electronics: A System Approach. 2nd ed. Printed and bound in Great Britain by Biddles Ltd, Guildford and King's Lynn, Addison Wesley Longman Limited. P.p314.
- [24] F.M.Klaassen and J.R.Robinson, "Anomalous Noise Behaviour of the Junction Gate Field Effect Transistor at Low Temperatures", IEEE Transactions. Electronic Devices, ED-17, 852-857 (1970).
- [25] C.F. Hiatt, A. van der Ziel and K.M. van Viet, "Generation-Recombination Noise Produced in the Channel of JFETs", IEEE Transactions. Electronic Devices, ED-22, 614-616 (1975).
- [26] Freeman, R.L. (2005) Fundamentals of telecommunications. West Sussex, UK: John Wiley. Pp. 90
- [27] Gosling, W. (1998) Radio Antennas and Propagation. Oxford: Newnes, 1998. P.p9, 41, 49 and 120.

[28] Altera. (2009) The Mathworks and Altera DSP Builder Collaboration [Online]. Available at: < http://www.altera.com/products/ip/altera/t-alt-matlab.html?GSA_pos=4&WT.oss_r=1&WT.oss=matlab >

Figures

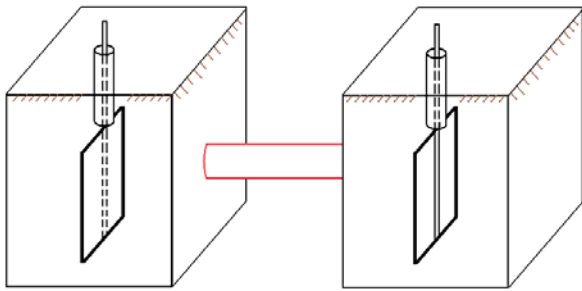

Figure 1: Prototype of the transmission medium

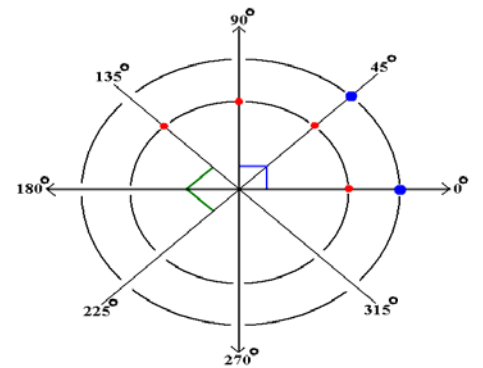
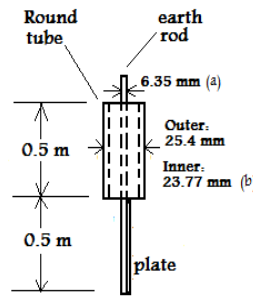

Figure 2: 16-QAM constellation

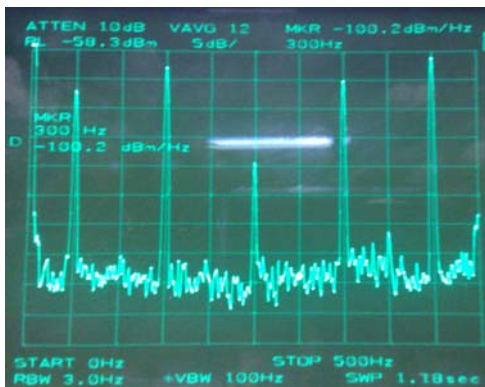

Figure 3: Ground spectrum

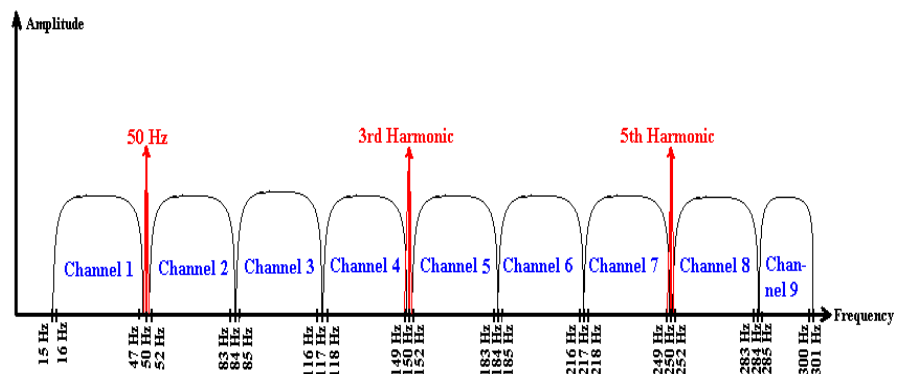

Figure 4: 9 channels allocated in the ELF band

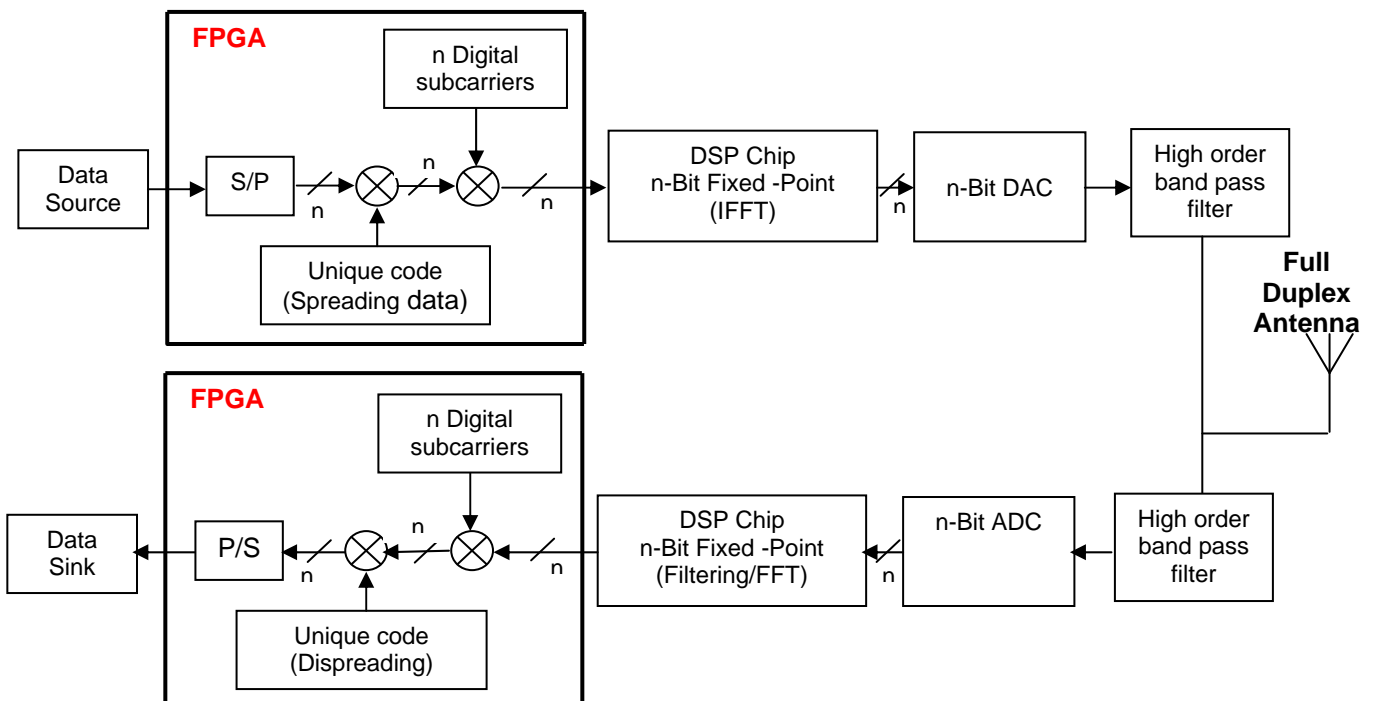

Figure (5) Transceiver design using FPGA, DSP, DAC and ADC chips and filters.