

# The Contribution of Small Modular Reactors to the Resilience of Power Supply

Francesco Di Maio<sup>a</sup>, Lorenzo Bani<sup>a</sup>, Enrico Zio<sup>a,b</sup>

<sup>a</sup>*Dipartimento di Energia, Politecnico di Milano, Milan, Italy*

<sup>b</sup>*Centre de recherche sur les Risques et les crises, MINES ParisTech/PSL Université Paris, France*

**Abstract** - In recent years, there has been a growing interest in the design, development and commercialization of nuclear power Small Modular Reactors (SMRs). Actual SMR designs cover the full spectrum of nuclear reactor technologies, including water-, gas-, liquid-metal-, and molten-salt-cooled. Despite physical and technological differences, SMRs share some relevant design features, such as small size, modularity, inherent and passive safety systems. These features are expected to enhance availability, recoverability, promptness and robustness, thereby contributing to the resilience of power supply. Thanks to the peculiar design features of SMRs, they are likely to satisfy a number of Functional Requirements (FRs) for this objective, namely: (i) low vulnerability to external hazards; (ii) natural circulation of primary coolant; (iii) prompt, unlimited and independent core cooling under shutdown conditions; (iv) shutdown avoidance in response to variations of the offsite power supply quality and electrical load; (v) island mode operation; (vi) robust load-following; (vii) independent, self-cranking start. These make advanced Nuclear Power Plants (aNPPs) comprised of SMRs perfect candidates to withstand a broader range of natural disruptions and to recover faster from them, compared to conventional Nuclear Power Plants (cNPPs), thus rendering them a major potential asset for guaranteeing resilience and security of power

supply. The review focuses on Natural Technological (NaTech) events that impact on a typical Integrated Energy System (IESs) within which SMRs are embedded: IESs are, indeed, being developed to integrate different power generation plants with gas facilities, through gas and electricity infrastructures, because expected to bring increased security and resilience of power supply, as shown in the qualitative case study presented.

**Keywords – Small Modular Reactors (SMRs), Design features, Integrated Energy Systems (IESs), Resilience, NaTech risk.**

<b>Acronyms</b>	
aNPP	advanced Nuclear Power Plant
<b>BWR</b>	<b>Boiling-Water Reactor</b>
CCGT	Combined Cycle Gas Turbine
cNPP	conventional Nuclear Power Plant
CRDM	Control Rod Drive Mechanism
CREA	Control Rod Ejection Accident
DHRS	Decay Heat Removal System
ECCS	Emergency Core Cooling System
FR	Functional Requirement
HES	Hybrid Energy System
<b>HTGR</b>	<b>High Temperature Gas-cooled Reactor</b>
IES	Integrated Energy System
IS	Inherent Safety
LBLOCA	Large Break Loss Of Coolant Accident
<b>LMFR</b>	<b>Liquid Metal-cooled Fast Reactor</b>
LOCA	Loss Of Coolant Accident
LOEL	Loss Of Electrical Load
LOFA	Loss Of Flow Accident
LOOP	Loss Of Offsite Power
LUHS	Loss of Ultimate Heat Sink
<b>LWR</b>	<b>Light-Water Reactor</b>
<b>MSR</b>	<b>Molten Salt Reactor</b>
NaTech	Natural Technological

NPP	Nuclear Power Plant
PHWR	Pressurized-Heavy-Water Reactor
PS	Passive Safety
PV	(solar) PhotoVoltaics
PWR	Pressurized-Water Reactor
P2G	Power-to-gas
RHRS	Residual Heat Removal System
SBLOCA	Small Break Loss Of Coolant Accident
SMR	Small Modular Reactor
SoS	system-of-systems
WF	Wind Farm

## I. INTRODUCTION

Design of Small Modular Reactors (SMRs) have been conceived starting from the early 1980s, in response to lessons learned from the technical and safety challenges posed by large, Generation II water-cooled reactors (e.g., the accident at Three Mile Island in 1979) [1]. They span over Generation III and III+ water-cooled reactor technologies, i.e., Pressurized-Water Reactor (PWR), Boiling-Water Reactor (BWR) and Pressurized-Heavy-Water Reactor (PHWR), to Generation IV concepts, i.e., High Temperature Gas-cooled Reactor (HTGR), Liquid Metal-cooled Fast Reactor (LMFR) and Molten Salt Reactor (MSR) [2]. Current designs share a similar philosophy founded on features such as small size, modularity, Inherent Safety (IS) and Passive Safety (PS) [3], that differentiate them from the large reactor units of the conventional Nuclear Power Plants (cNPPs).

Advanced Nuclear Power Plants (aNPPs), comprised of one or more SMR units, are foreseen to play a role in guaranteeing resilience and security of power supply in response to climate change within both recent proposal of power production systems such as Hybrid Energy Systems (HESs), wherein multiple energy inputs (e.g., nuclear, fossil and renewables) are

converted into multiple energy products (e.g., electricity, gasoline and fresh water) using complementary energy conversion processes [4], [5], and Integrated Energy Systems (IESs), which are systems-of-systems (SoSs) that include production plants (e.g., from nuclear, fossil and renewable sources), energy conversion (e.g., power-to-gas), storage (e.g., energy hubs), gas and electricity infrastructures to supply end users (e.g., residential, commercial and industrial customers) and lifelines (e.g., water, transportation) [6]. As a matter of fact, the increasing penetration of renewables with intermittent generation and the need of dealing with time-varying loads pose significant challenges to the stability of the electric grid [4]; this is exacerbated by climate change and the increased risk of Natural Technological (NaTech) accidents. Under these conditions, there is a request of flexibility and resilience of the individual power plants and the infrastructure to render the energy provision secure and the overall energy system resilient, also against NaTech accidental scenarios [6], [7]. For these reasons, several countries, including Britain, Canada, Japan and China, have decided to explore the IESs option, resulting in the INTENSYS4EU project [8], EU ELECTRA Demonstration Project [9], Japan's Baiye Smart City [10], Tongli New Energy Town Project [11] and Shanghai Chongming Island Demonstration Project [12], [13], that have all confirmed the relevance of IESs to allow for a sustainable and resilient development.

When we consider the nuclear energy source as an option for the energy transition within the IES [14], [15], the design features of SMRs are fitting the scope, with increased safety for a broad range of normal and off-design operating conditions. With respect to the former, SMRs are typically designed to be equipped with turbine bypass systems and battery energy storage systems to provide satisfactory flexibility, allowing them to cope with highly variable renewable energy sources within IESs [16] while keeping the reactor within prescribed design limits (defined in terms of the rate of change, total change, and total number of large power cycle over the reactor lifetime), thus limiting thermal fatigue and corrosion of components, and

reliance on frequent use of control rods for core power redistribution [17], [18]. As for the latter, for example, IS eliminates some potential accident initiators by design (e.g., the integral reactor vessel layout of several SMR designs limits the occurrence of Large Break Loss Of Coolant Accidents (LBLOCAs) [2], [19]) and PS mitigates the escalation of accidents, thereby reducing the probability of severe consequences (e.g., natural circulation allows maintaining passive core cooling in the event of Loss Of Offsite Power (LOOP), without the need of relying on emergency power systems, such as diesels or batteries, to drive the circulation pumps [2], [19]) [20].

In this work, we aim at illustrating the contribution of SMRs to the resilience of IESs, particularly with reference to NaTech accidental scenarios. To this aim, we refer to the NPPs Functional Requirements (FRs, listed in *Table I*) and highlight those useful for resilience. Each specific FR addresses one or more essential resilience attribute [21], [22]: FR 1 assures that the NPP is capable of withstanding and absorbing credible external events, avoiding dependent failure mechanisms with other elements of the IESs, thereby favoring IESs recovery and restoration operations; FRs 2, 3 and 7 make NPPs independent from the offsite power supply, in normal operation as well as in shutdown conditions; FR 4 assures that the NPPs are not made unavailable by events in which their power supply is necessary; FR 5 reduces the NPPs recovery time to support the IESs operation; FR 6 implies that the NPPs are to work in traditional baseload configuration, as well as in load-follow configuration.

The remainder of this paper is organized as follows: in Section II, the relevant SMRs design features, the corresponding FRs that they enable, and the expected enhancement of IESs resilience to NaTech events that they bring are presented; Section III illustrates a case study of reference for a qualitative comparison of the contribution to IESs resilience by large reactors and SMRs; conclusions and an outlook on future work are given in Section IV.

## II. SMRs DESIGN FEATURES FOR IESs RESILIENCE

*Table I* lists the FRs that a NPP is required to meet for the resilience of an IES to NaTech events. As we shall see, aNPPs give more guarantee to meet such FRs than cNPPs do, due to SMRs design features such as integral reactor vessel layout, increased relative coolant inventory and relative pressurizer volume, smaller diameter and taller reactor vessel, smaller fuel inventory, below-grade construction of the reactor building, smaller size and modularity [2], [19], as summarized in *Table II* and discussed below. It should be noted that values reported in *Table II* are subject to constraints associated with the current limited availability of SMR related design information and that, even for the same type of SMR, differences in the values should be acknowledged due to site specific design.

*II.A. Integral reactor vessel layout.* In the wake of the reduced core size, several SMRs based either on PWR (e.g., NuScale, mPower and W-SMR designs) or MSR (e.g., IMSR) or LMFR (e.g., LFR-TL-X, BREST-OD-300 and PGSFR) technologies, adopt an integral design in which all (or most of) the primary system components are incorporated inside a single vessel [2]. This is recognized as a peculiar IS feature (among others), since it allows deliberately avoiding hazards, rather than controlling them [23]. Indeed, the integral reactor vessel layout greatly reduces the number and size of penetrations (i.e., primary coolant pipes) through the reactor vessel and, therefore, practically eliminates LBLOCAs [1], [3], [19], [20] which can be triggered by earthquakes [24], [25]; if the Control Rod Drive Mechanism (CRDM) is also within the integral reactor vessel, Control Rod Ejection Accidents (CREAs) are practically eliminated, as well [2], [19]. Therefore, many undesired event sequences that can lead to a large or early release of radioactivity are avoided by adopting an integral design, and safety margins are consequently improved. An integral design enables the NPP to meet the FR 1 (i.e., low vulnerability to external hazards), because the likelihood of the occurrence of severe reactor

1. Low vulnerability to external hazards
2. Natural circulation of primary coolant
3. Prompt, unlimited and independent core cooling under shutdown conditions
4. Shutdown avoidance in response to variations in the offsite power supply quality and electrical load
5. Island mode operation
6. Robust load-following
7. Independent, self-cranking start

**Table I.** Functional Requirements (FRs) of NPPs

TYPE(S) OF SMR	DESIGN FEATURE	DESIGN RANGE	FR(s) ENABLED	REFERENCES
PWR MSR LMFR	Integral reactor vessel layout	N/A	1	[1], [2], [3], [19], [26]
PWR LMFR	Increased relative coolant inventory	~ 3500 – 4000 kg/MWth ~ 220 – 240 kg/MWth	1	[1], [19], [26], [27], [28], [29], [30]
PWR	Increased relative pressurizer volume	N/A	1	[1]
LWR HTGR MSR	Small diameter ( $D$ ) and high ( $H$ ) reactor vessel	$D > 3\text{ m}, H > 10\text{ m}$ $D > 5\text{ m}, H > 15\text{ m}$ $D > 3\text{ m}, H > 10\text{ m}$	1, 2, 3	[1], [2], [26]
All	Small fuel inventory	N/A	1, 3	[1], [19], [26]
(Possibly) all	Below-grade construction of the reactor building	~ 30 – 100% below ground level	1	[1], [2], [3], [26]
All	Small size	Nominal power < 300 MWe	3, 5, 7	[1], [2], [3], [19], [26]
(Possibly) all	Modularity	# of reactor modules $\geq 1$	1, 3, 4, 5, 6, 7	[1], [2], [3], [19], [26]

**Table II.** Design features of SMRs that enable the FRs of Table I

core accidents is reduced, and the IES resilience is increased.

*II.B. Increased relative coolant inventory and relative pressurizer volume.* For those SMRs with an integral design (i.e., all or most the primary components are within the reactor vessel, as explained above), the vessel, the coolant inventory and (where applicable) pressurizer volume per unit of power are larger than for loop-type configurations [1], [2], [19]. In water-cooled SMRs, this significantly increases the relative thermal inertia within the reactor vessel, due to the favorable heat capacity of water during Loss of Ultimate Heat Sink (LUHS) transients, e.g., those potentially triggered by tsunami accidents [31], therefore resulting in a longer coping time, i.e., the period between the start of an accident and the operator action is longer [1], [19]. The features of increased relative coolant inventory and relative pressurizer volume, then, enable the NPP to meet the FR 1 (i.e., low vulnerability to external hazards), because the likelihood of the occurrence of severe reactor core accidents is reduced, and the IES resilience is increased.

*II.C. Small diameter and high reactor vessel.* Integral design and transportation constraints lead to vessels with larger height-to-diameter (aspect) ratios than those of typical, large LWRs (i.e., 2 vs 3-6 of most PWR-based and various HTGR-based SMRs [2]). The larger aspect ratio facilitates the buoyancy-driven flow paths in the primary coolant (i.e., for PS), that allow for natural circulation, a better thermal coupling in radial direction between the core and the vessel (smaller distance from the core centerline to the reactor vessel), and an increase in the relative vessel area per unit power. The combination of smaller diameter and higher reactor vessel leads to an enhanced heat removal, that is estimated two-to-four times larger than for a typical, large LWR [1]. This allows most SMRs to cool down safely in case of a LOOP event without relying on the availability of pumps and motors to run plant safety systems. Additionally, in many SMRs, especially HTGR-based (such as HTR-PM [2]), thanks also to the fuel form (i.e., TRISO coated fuel particles enclosed in graphite matrices) and coolant (i.e., CO<sub>2</sub> or helium), the



decay heat is passively removed from the core under any accident conditions by natural mechanisms, such as heat conduction or radiation [32]. This, again, leads to larger safety margins and reduces the probability of core melt and large releases of radioactivity into the environment. Higher reactor vessel and smaller core decay heat, then, enable the NPP to meet the FR 1 (i.e., low vulnerability to external hazards), FR 2 (i.e., natural circulation of primary coolant) and FR 3 (i.e., prompt, unlimited and independent core cooling under shutdown conditions), because the heat removal from the core and the vessel (in both axial and radial directions) is more effective and, in turn, the IES resilience is increased.

*II.D. Small fuel inventory and below-grade construction of the reactor building.* Due to their reduced power output ( $< 300 \text{ MWe}$ ), SMRs have a significantly lower fuel inventory than large reactors [2], [19]. Consequently, the core decay heat is reduced and the release of radioactive contaminants (i.e., the source term) during a nuclear accident is expected to be smaller. Also, since the reactor buildings of SMRs may be constructed below-grade, i.e., totally or partially below ground, thanks to a smaller footprint that makes them more economically viable [1], release paths of source term are reduced. In other words, SMRs are expected to have larger safety margins and lower large release frequency compared to large scale cNPPs, making it viable the siting of SMRs close by populated areas. Additionally, below-grade construction significantly hardens the system against some external natural events (e.g., earthquakes) [26]. Then, the smaller fuel inventory and the below-grade construction of the reactor building enable the NPP to meet the FR 1 (i.e., low vulnerability to external hazards) and FR 3 (i.e., prompt, unlimited and independent core cooling under shutdown conditions), because the shutdown decay power produced by the core and the potential radiological consequences of nuclear accident are reduced, and the IES resilience is, then, increased.

*II.E. Small size.* The small size ( $< 300 \text{ MWe}$ ) of SMRs brings several advantages [22]. First, shutdown cooling power requirements are reduced, likely to levels achievable with passive

cooling systems. Then, small size enables a single SMR unit installed within a multiple-unit NPP to operate, at the same time supplying housekeeping power (i.e., reduced power level) or shutdown cooling power (i.e., island mode) to the other reactor units. Finally, the cranking power requirements for small-sized reactors are few MWe [33], enabling the plant to use both large diesels and non-conventional cranking supplies (e.g., batteries, solar photovoltaic systems and fuel cells). In all, the small size of SMRs enables the NPP to meet the FR 3 (i.e., prompt, unlimited and independent core cooling under shutdown conditions), FR 5 (i.e., island mode operation) and FR 7 (i.e., independent, self-cranking start), with an associated increase in the IES resilience.

*II.F. Modularity.* Most of SMRs envision incremental deployment to closely match evolving energy demands and increase operational flexibility [2], [19]. NPPs comprising multiple-unit SMRs benefit from enhanced load-following capability [22], housekeeping and core cooling power suppliance to other SMR units in the NPP that might have failed (i.e., island mode operation) or starting up (i.e., cranking power) following LOOP accidents, e.g., triggered by floods [34], in absence of primary coolant natural circulation. In addition, when multiple SMR units are built on the same site to meet an equivalent energy demand as a cNPP, the occurrence of an accident scenario that result in fuel failure in all SMR units concurrently is highly unlikely, consequently the probability of a large radiation release is reduced [32]. Finally, the allocation of multiple SMR units reduce the cranking power supply required to restart the entire plant (i.e., equal to one SMR unit crank) [22]. Modularity, then, is seeing to enable the plant to meet FRs 1, 3, 4, 5, 6 and 7, with an associated increase in the IES resilience.

### III. CASE STUDY

We consider an IES of literature [6] comprised of two Combined Cycle Gas Turbine (CCGTs) plants, a NPP, two Wind Farms (WFs), a Solar Photovoltaics (PV) field and a Power-to-gas (P2G)

station. The IES considered is plotted in Fig. 1 (where the black line is the electrical grid and the blue line is the gas grid). We assume that the IES can have four different configurations depending on the type of NPP that is therein integrated: a cNPP consisting of a single 360 MWe large reactor unit, or three alternative aNPPs consisting of multiple identical SMR units, for the same total nameplate capacity of 360 MWe. The cNPP and aNPPs differ in terms of number of reactor units (i.e., 1, 2 or 4) and design features (e.g., size, reactor vessel layout, aspect ratio, level of reactor building, etc.), thus meeting some (or all) the FRs presented in Section II, as listed in *Table III*. For each configuration, the benefit on the IES resilience of different SMR technologies is hereafter compared to that of a typical large reactor, with respect to several realistic accidental scenarios that might be triggered by the occurrence of a generic NaTech event, e.g., initiated by an earthquake, a tsunami, etc.

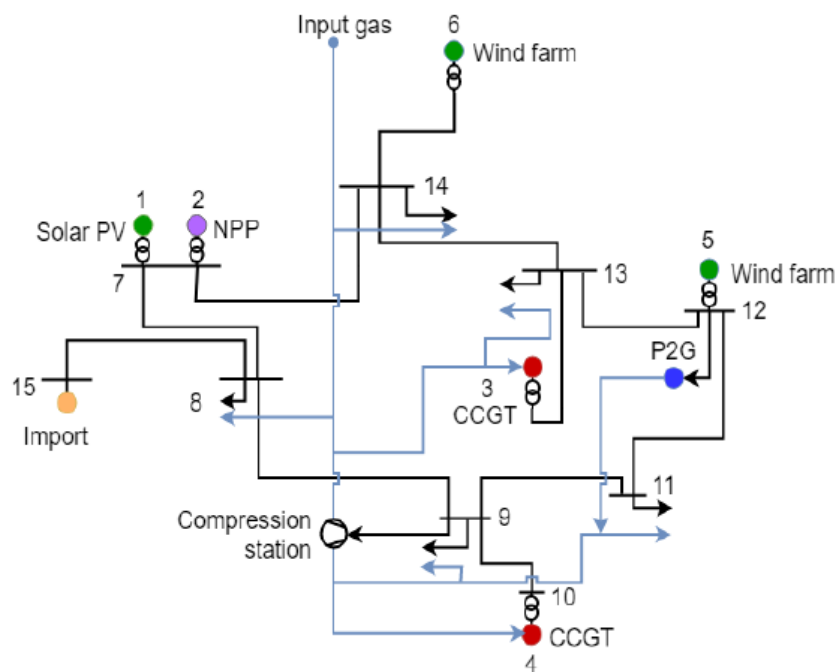

**Fig. 1.** Scheme of the considered IES

	cNPP	aNPP-1	aNPP-2	aNPP-3
Number of reactor units	1	2	4	4

Rated power level [ <i>MWe</i> ] per reactor unit	360	180	90	90
Fuel inventory per reactor unit*	$x$	$\sim x/2$	$\sim x/4$	$\sim x/4$
Integral reactor vessel layout	no	yes	no	yes
Aspect ratio	$< 2$	2~3	$> 5$	3~4
Construction of the reactor building	above-grade	above-grade	above-grade	below-grade
Modularity	absent	poor	good	good
Fully met FRs	/	3, 6, 7	3, 4, 5, 6, 7	1, 2, 3, 4, 5, 6, 7
Partially met FRs	1	1	1	/
Unmet FRs	2, 3, 4, 5, 6, 7	2, 4, 5	2	/

\*the fuel inventory of a reactor core is a value roughly proportional to the rated power level

**Table III.** The considered NPPs configurations

For the cNPP, aNPP-1 and aNPP-2, given that they only partially meet the FR 1, the occurrence of an IES-wide NaTech event can (or not) directly damage the NPP depending on the level of vulnerability to the considered external event: if vulnerability is low, the NPP is likely not damaged, whereas other production plants are (represented in Fig. 2, where the red circle refers to cNPP, black triangle to aNPP-1 and blue diamond to aNPP-2); vice versa, if it is high. The aNPP-3 (represented in Fig. 2 by the green star), given its design features suitable to withstand the natural hazard (i.e., integral reactor vessel layout and below-grade construction of reactor buildings), is assumed to fully meet the FR 1 and, therefore, to not be directly damaged by the occurrence of an IES-wide NaTech event. If, in the case of high NPP vulnerability, we further assume that a direct damage to the NPP evolves in a LOOP, combined either with a Loss Of Coolant Accident (LOCA) (more specifically, either a Small Break LOCA (SBLOCA) or a LBLOCA depending on the reactor vessel layout) or another non-LOCA (i.e., Loss Of Flow Accident (LOFA) and, except for the aNPP-1 which has an integral layout, Control Rod Ejection Accident (CREA)), followed by a forced shutdown of the plant and activation of one or

more safety systems (i.e., active or passive Emergency Core Cooling System (ECCS), active Residual Heat Removal System (RHRS) or passive Decay Heat Removal System (DHRS)), it may occur that: for the cNPP, since the safety systems (i.e., active ECCS and RHRS) are to be equipped with emergency pumping systems, such as diesel generators or batteries (of limited availability), safe shutdown cooling is ensured for a limited period of time only and, then, external support is needed; conversely, the aNPPs can rely on indefinite shutdown cooling thanks to the passive safety systems (i.e., passive ECCS and DHRS), without reliance on either emergency or offsite power. If, on the other hand, the vulnerability of the NPP to external events is low and we assume that damages may occur to other production plants within the IES we may face either a partial or complete Loss Of Electrical Load (LOEL) and/or a LOOP event: in case of a LOOP event, the modular aNPPs (i.e., aNPP-2 and aNPP-3) that enable high operational flexibility (i.e., FRs 4 and 6) can allocate one or more SMR units to supply housekeeping and (if needed) core self-cooling power, while the other reactor units still retain as much power capacity as possible. Clearly, the reduction of the power output is smaller for the aNPP-3 than for the aNPP-2, since the natural primary coolant circulation of the former (FR 2) does not imply any circulation pumps to be powered. Either way, since the aNPP-2 and aNPP-3 can avoid the shutdown in response to such upset conditions, they constitute a significant power asset to allow for the restoration operations of damaged parts of the IES.

Second, in case of a LOOP event combined with a complete LOEL, the aNPP-2 and aNPP-3, by virtue of their high operational flexibility and size of the reactor units (90 MWe), can switch to island mode operation (FR 5), that consists in isolating the NPP from the electrical grid and reducing its power level to that required to meet only its own housekeeping electrical loads; on the contrary, as in the case of a LOOP event alone, the cNPP and the aNPP-1 can only be shutdown, because of their size and/or poor (or absent) modularity that do not allow for flexible operations [21]. However, the aNPP-1, owing to its (passive) DHRS, is still

independently capable of providing almost unlimited shutdown cooling (FR 3) and self-cranking as soon as the offsite power supply is restored (FR 7), thus still contributing to the resolution of the electrical grid anomaly. For the cNPP, instead, in absence of offsite power the (active) RHRS must be supplied by emergency power and, thus, shutdown cooling can only be provided for a short period of time, so that external support is soon required for guaranteeing safe shutdown cooling. Also, cNPP self-cranking is not a viable option, due to the large cranking power requirements, typical of large reactors, that cannot be met by emergency diesel generators: hence, substantial offsite power is required for starting back up the plant once the electric grid anomaly is solved. In this sense, the cNPP constitutes a burden on, rather than an asset to, the IES during recovery operations. In case of a partial LOEL, all the aNPPs, thanks to their robust load-following capability (FR 6) enabled by the modularity feature, can easily meet varying and dynamic load demands (e.g., from rated power level down to housekeeping loads) by reducing the power level of one or more SMR units, therefore playing a supportive role in IES restoration activities. Conversely, the cNPP would follow the “shutdown and wait” approach [21]. This, although safe shutdown cooling is ensured indefinitely (i.e., RHRS is supplied by offsite power), may exacerbate the accidental scenario consequences since power generating capacity would be removed precisely at the time it is needed to stabilize and restore the IES. In addition, if the cNPP covers a predominant fraction of the overall IES power generating capacity, its isolation from the electrical grid after a partial LOEL may lead to the shutdown of the other elements within the IES (e.g., production plants, transmission assets, etc.), and to a cascading collapse of larger portions of the IES [35]: again, the cNPP would constitute a burden on IES recovery operations.

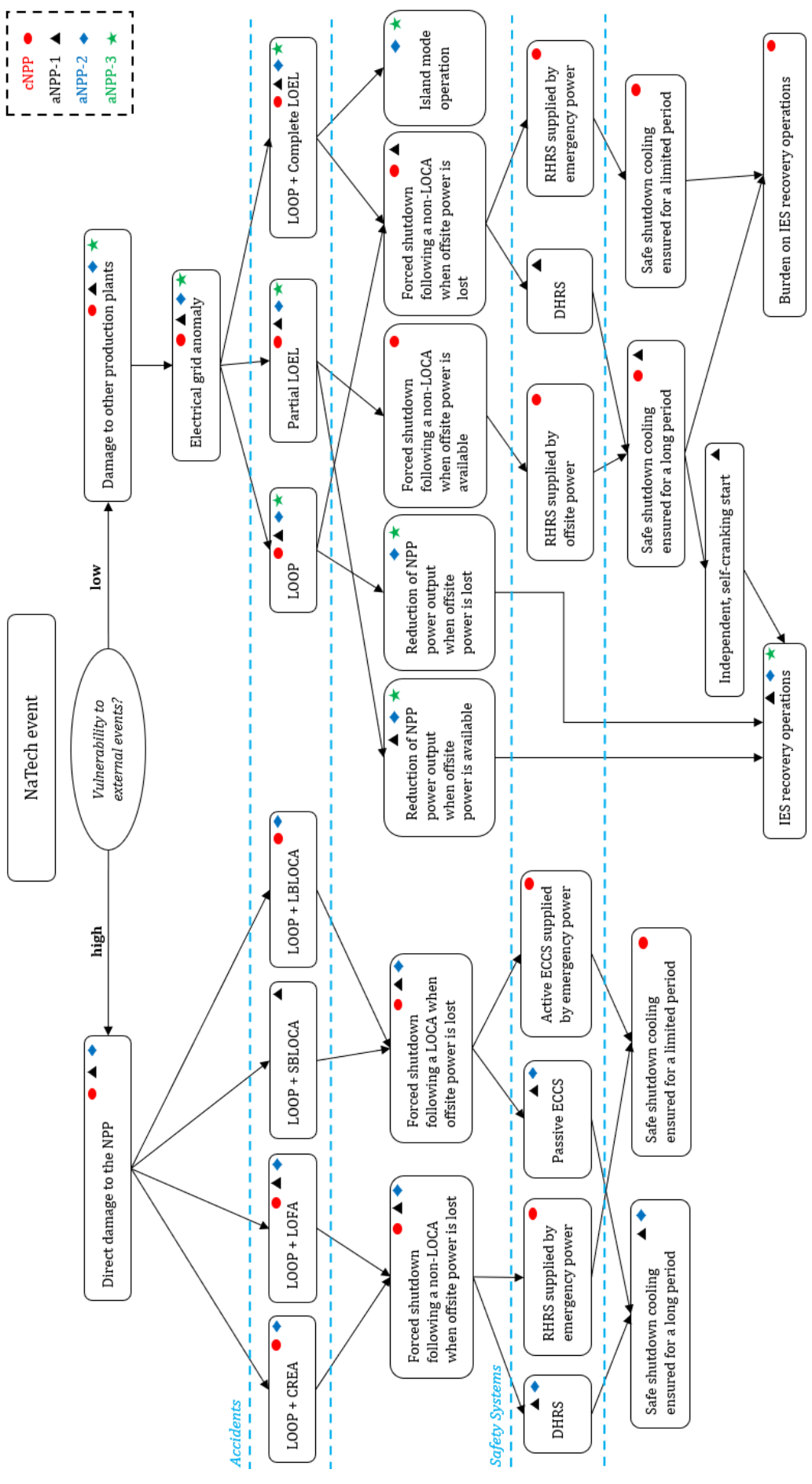

**Fig. 2.** Sketch of the similarities and differences between the evolution of scenarios following the occurrence of an IES-wide NaTech event, for the cNPP and the aNPPs

#### IV. SUMMARY AND CONCLUSIONS

Climate change exposes technological installations to NaTech accidental scenarios potentially more frequent and violent than before. In this paper, we have considered the vulnerability of power systems to NaTech accidents, within an IES configuration. Seven FRs of power systems have been presented and discussed, in view of their contribution to IESs resilience against NaTech accident events. The particular focus is on NPPs within IESs. It has been pointed out that aNPPs are more likely to meet the FRs than the cNPPs, thanks to the design features of SMRs. Then, aNPPs are expected to withstand and recover from a broad range of extreme conditions induced by NaTech events and, therefore, they represent good candidates for integration within IESs, for providing further resilience. A qualitative case study has been discussed to substantiate, on a realistic IES equipped with alternative configurations of NPPs, the generality of the conclusions drawn: aNPPs bring an overall greater benefit to the resilience of a typical IES of literature exposed to a generic NaTech event than cNPPs. To make this effort valuable for the practical licensing of SMRs, future activity will concern the confirmation of the findings by a quantitative assessment of the benefits of a targeted SMR design to IESs resilience: to do this, simulation codes of both the targeted SMR and the IES it is foreseen to be integrated with will have to be implemented, all the typical preparatory analysis conducted, including sensitivity analysis and uncertainty quantification, and the quantification of resilience indexes to be performed, in support a resilience-informed decision-making.

#### Acknowledgments

This study was developed within the research project “Assessment of Cascading Events triggered by the Interaction of Natural Hazards and Technological Scenarios involving the



release of Hazardous Substances” funded by MIUR - Italian Ministry for Scientific Research under the PRIN 2017 program (grant 2017CEYPS8).

## References

- [1] D. T. Ingersoll, “An overview of the safety case for small modular reactors,” in *Small Modular Reactors Symposium*, 2011, vol. 54730, pp. 369–373.
- [2] IAEA, “ADVANCES IN SMALL MODULAR REACTOR TECHNOLOGY DEVELOPMENTS 2020 Edition A Supplement to: IAEA Advanced Reactors Information System (ARIS),” 2020. [Online]. Available: <http://aris.iaea.org>
- [3] E. M. A. Hussein, “Emerging small modular nuclear power reactors: A critical review,” *Physics Open*, vol. 5. Elsevier B.V., Dec. 01, 2020. doi: 10.1016/j.physo.2020.100038.
- [4] H. E. Garcia *et al.*, “Dynamic performance analysis of two regional Nuclear Hybrid Energy Systems,” *Energy*, vol. 107, pp. 234–258, Jul. 2016, doi: 10.1016/j.energy.2016.03.128.
- [5] J. Chen, H. E. Garcia, J. S. Kim, and S. M. Bragg-Sitton, “Operations optimization of nuclear hybrid energy systems,” *Nuclear Technology*, vol. 195, no. 2, pp. 143–156, Aug. 2016, doi: 10.13182/NT15-130.
- [6] F. di Maio, P. Tonicello, and E. Zio, “A Modeling and Analysis Framework for Integrated Energy Systems Exposed to Climate Change-Induced NaTech Accidental Scenarios,” *Sustainability*, vol. 14, no. 2, pp. 1–19, 2022, [Online]. Available: <https://EconPapers.repec.org/RePEc:gam:jsusta:v:14:y:2022:i:2:p:786-:d:722268>
- [7] F. Sissine, “Energy Independence and Security Act of 2007: a summary of major provisions,” 2007.
- [8] EU Commission, “INTegrated ENergy SYStem, a pathway for EUrope (INTENSYS4EU),” *CORDIS*, Oct. 01, 2016. <https://cordis.europa.eu/project/id/731220/it>

- [9] EU Commission, "Electricity driven Low Energy and Chemical input Technology for Accelerated bioremediation (ELECTRA)," *CORDIS*, Jan. 01, 2019.  
<https://cordis.europa.eu/project/id/826244>
- [10] J. Liu, J. Liu, Y. Tan, and Q. Sun, "Characteristic of Integrated energy system and brief description on typical demonstration project," in *2019 14th IEEE Conference on Industrial Electronics and Applications (ICIEA)*, 2019, pp. 1348–1353. doi: 10.1109/ICIEA.2019.8834105.
- [11] X. Zhang, J. Zhao, X. Yuan, and D. Yuan, "Analysis of collaborative control technology and demonstration project of integrated energy system," *IOP Conference Series: Earth and Environmental Science*, vol. 227, p. 042039, 2019, doi: 10.1088/1755-1315/227/4/042039.
- [12] Y. Liu, H. Li, K. Peng, C. Zhang, H. Hua, and L. Wang, "Demonstration projects of integrated energy system in China," *Energy Procedia*, vol. 145, pp. 88–96, 2018.
- [13] R. Guo and H. Yang, "Roadmap of renewable energy industry development in Chongming Ecoisland," *Journal of Tongji University. Natural Science*, vol. 40, no. 8, pp. 1204–1209, 2012.
- [14] NEA, "Advanced Nuclear Reactor Systems and Future Energy Market Needs," 2021.
- [15] IEA, "World Energy Outlook 2021," Paris, 2021. [Online]. Available: [www.iea.org/weo](http://www.iea.org/weo)
- [16] B. Poudel and R. Gokaraju, "Small Modular Reactor (SMR) Based Hybrid Energy System for Electricity & District Heating," *IEEE Transactions on Energy Conversion*, vol. 36, no. 4, pp. 2794–2802, 2021, doi: 10.1109/TEC.2021.3079400.
- [17] G. B. Lazarev, V. A. Hrustalyov, and M. v Garievskij, "Non-baseload operation in nuclear power plants: load following and frequency control modes of flexible operation," *Nuclear Energy Series*, vol. 173, 2018.
- [18] A. Lokhov, "Technical and economic aspects of load following with nuclear power plants," *NEA, OECD, Paris, France*, vol. 2, 2011.
- [19] NEA, "Small Modular Reactors: Challenges and Opportunities," 2021.

- [20] C. Zeliang, Y. Mi, A. Tokuhiko, L. Lu, and A. Rezvoi, "Integral PWR-type small modular reactor developmental status, design characteristics and passive features: A review," *Energies*, vol. 13, no. 11. MDPI AG, Jun. 01, 2020. doi: 10.3390/en13112898.
- [21] S. R. Greene, "Are current U.S. Nuclear power plants grid resilience assets?," *Nuclear Technology*, vol. 202, no. 1, pp. 1–14, Apr. 2018, doi: 10.1080/00295450.2018.1432966.
- [22] S. R. Greene, "The Key Attributes, Functional Requirements, and Design Features of Resilient Nuclear Power Plants (rNPPs)," *Nuclear Technology*, vol. 204, no. 2, pp. 131–146, Nov. 2018, doi: 10.1080/00295450.2018.1480213.
- [23] "Safety related terms for advanced nuclear plants," 1991.
- [24] S. W. Kim, B. G. Jeon, D. G. Hahm, and M. K. Kim, "Ratcheting fatigue failure of a carbon steel pipe tee in a nuclear power plant using the deformation angle," *Engineering Failure Analysis*, vol. 114, Aug. 2020, doi: 10.1016/j.engfailanal.2020.104595.
- [25] Y. Yu, X. Lv, and F. Niu, "Large LOCA accident analysis for AP1000 under earthquake," *Annals of Nuclear Energy*, vol. 77, pp. 142–147, 2015, doi: 10.1016/j.anucene.2014.11.013.
- [26] J. Morales Pedraza, "Safety Designs of Small Modular Reactors," in *Small Modular Reactors for Electricity Generation*, Vienna: Springer International Publishing, 2017, p. 64. doi: 10.1007/978-3-319-52216-6.
- [27] IAEA, "Status Report – NuScale SMR (NuScale Power, LLC) United States of America," May 2020. [Online]. Available: [https://aris.iaea.org/PDF/NuScale-NPM200\\_2020.pdf](https://aris.iaea.org/PDF/NuScale-NPM200_2020.pdf)
- [28] IAEA, "Status Report – NUWARDTM (EDF lead consortium) France," Nov. 2019. [Online]. Available: [https://aris.iaea.org/PDF/F-SMR\\_2020.pdf](https://aris.iaea.org/PDF/F-SMR_2020.pdf)
- [29] IAEA, "Status Report – Westinghouse Lead Fast Reactor (Westinghouse Electric Company LLC, United States of America)," 2019. [Online]. Available: [https://aris.iaea.org/PDF/W-LFR\\_2020.pdf](https://aris.iaea.org/PDF/W-LFR_2020.pdf)

- [30] IAEA, "Status Report – 4S (Toshiba Energy Systems & Solutions Corp./Japan)," Oct. 2019. [Online]. Available: [https://aris.iaea.org/PDF/Toshiba-4S\\_2020.pdf](https://aris.iaea.org/PDF/Toshiba-4S_2020.pdf)
- [31] B. Fujioka, N. Hirokawa, and D. Taniguchi, "PROBABILISTIC ASSESSMENT OF COUNTERMEASURES FOR LOSS OF ULTIMATE HEAT SINK TO SPENT FUEL POOL," 2017. [Online]. Available: <http://www.asme.org/about-asme/terms-of-use>
- [32] J. Morales Pedraza, "Benefits of Small Modular Reactors," in *Small Modular Reactors for Electricity Generation*, Cham: Springer International Publishing, 2017, pp. 241–247. doi: 10.1007/978-3-319-52216-6.
- [33] E. Makay, M. L. Adams Jr, and W. Shapiro, "Design and Procurement Guide for Primary Coolant Pumps Used in Light-Water-Cooled Nuclear Reactors," *published by the Atomic Energy Commission (November 1972). ORNL-TM-3956, 1972.*
- [34] L. Cui, M. Liao, T. Lv, and Y. Chen, "The severe accident analysis for fukushima daiichi unit 2 nuclear power station," in *International Congress on Advances in Nuclear Power Plants, ICAPP 2013: Nuclear Power - A Safe and Sustainable Choice for Green Future, Held with the 28th KAIF/KNS Annual Conference, 2013*, pp. 833–842. [Online]. Available: <https://www.scopus.com/inward/record.uri?eid=2-s2.0-84925185671&partnerID=40&md5=5a64b1727591d224762d6ce8c405ffe7>
- [35] F. di Maio, S. Morelli, and E. Zio, "A Novel Probabilistic Framework for the Assessment of the Adequacy of Integrated Energy Systems Under Changing Climate Scenarios."