

Aus dem Institut für Phytomedizin
Universität Hohenheim
Fachgebiet: Angewandte Entomologie Prof. Dr. C.P.W. Zebitz

**Characterization of mechanisms of resistance to
common insecticides in noctuid pest species and resistance
risk assessment for the new lepidopteran specific
compound flubendiamide**

**Dissertation
zur Erlangung des Grades eines Doktors
der Agrarwissenschaften**

vorgelegt

der Fakultät Agrarwissenschaften

von

Stefanie Konanz

aus Pforzheim

2009

Die vorliegende Arbeit wurde am 3. Juni 2009 von der Fakultät Agrarwissenschaften der Universität Hohenheim als "Dissertation zur Erlangung des Grades eines Doktors der Agrarwissenschaften" angenommen.

Tag der mündlichen Prüfung: 10. Juli 2009

1. Prodekan: Professor Dr. W. Bessei

- | | |
|---------------------------------|-----------------------------|
| 1. Prüfer, Berichterstatter: | Professor Dr. C.P.W. Zebitz |
| 2. Prüfer, Mitberichterstatter: | Professor Dr. W. Schwack |
| 3. Prüfer: | Professor Dr. R. Blaich |

TABLE OF CONTENTS

1	INTRODUCTION	1
1.1	BIOLOGY LEPIDOPTERA: NOCTUIDAE	1
1.2	<i>SPODOPTERA EXIGUA</i>, <i>HELICOVERPA ARMIGERA</i> AND <i>HELIOTHIS VIRESCENS</i>	2
1.3	LEPIDOPTERAN SPECIES – IMPORTANT INSECTICIDES	3
1.3.1	History – Development of the lepidopteran insecticide market.....	3
1.3.2	General overview of the world market for insecticides	4
1.3.3	“Old Chemistry”	6
1.3.3.1	Pyrethroids	6
1.3.3.2	Carbamates and organophosphates	7
1.3.3.3	Cyclodienes	8
1.3.3.4	Benzoylphenyl ureas	9
1.3.4	“New Chemistry”	10
1.3.4.1	Indoxacarb	10
1.3.4.2	Emamectin	10
1.3.4.3	Spinosad	11
1.3.4.4	Chlorfenapyr	12
1.3.4.5	Moulting accelerating compounds (diacylhydrazines)	12
1.3.4.6	Flubendiamide	13
1.3.4.7	Flubendiamide a new tool on the insecticide market	14
1.4	RESISTANCE	15
1.5	OVERVIEW OF RESISTANCE MECHANISMS IN INSECTS	16
1.5.1	Penetration and behavioural resistance.....	17
1.5.2	Metabolic resistance	17
1.5.2.1	Glutathione S-transferases	17
1.5.2.2	Carboxylesterases	18
1.5.2.3	Cytochrome P ₄₅₀ -dependent monooxygenases	19
1.5.3	Altered target-site resistance.....	20
1.5.3.1	GABA receptor: target-site resistance to cyclodienes	20
1.5.3.2	Insensitive AChE: target-site resistance to carbamates and organophosphates	21
1.5.3.3	Nerve insensitivity: target-site resistance to pyrethroids	22
1.6	RESISTANCE MANAGEMENT	24
1.6.1	Cross-resistance	24
1.6.2	Integrated pest and insecticide resistance management.....	25
2	OBJECTIVE	27

3	MATERIAL AND METHODS	29
3.1	CHEMICALS AND INSECTICIDES	29
3.1.1	Chemicals and reagents	29
3.1.2	Insecticides and synergists.....	29
3.2	LEPIDOPTERAN STRAINS	29
3.3	BIOASSAYS	30
3.3.1	Larval spray bioassay	30
3.3.2	Larval artificial diet bioassay.....	31
3.3.3	Worldwide monitoring	31
3.3.4	Application and synergism studies	32
3.3.5	Pharmacokinetic studies	33
3.4	BIOCHEMISTRY	35
3.4.1	Protein determination	35
3.4.2	Glutathione S-transferases	35
3.4.2.1	Standard photometric assay using 1-chloro-2,4-dinitrobenzene as substrate	35
3.4.2.2	Fluorometric assay using monochlorobimane as substrate	36
3.4.3	Carboxylesterases	36
3.4.3.1	Photometric assay with 1-naphthyl acetate	36
3.4.3.2	nPAGE and inhibition studies	37
3.4.4	Cytochrome P ₄₅₀ -dependent monooxygenases	38
3.4.4.1	Fluorometric assay to measure 7-ethoxycoumarin O-deethylation	38
3.4.5	Acetylcholinesterases	39
3.4.5.1	Photometric determination of acetylcholinesterase activity	39
3.4.5.2	Inhibition studies and determination of kinetic parameters	40
3.4.6	Affinity purification of acetylcholinesterases	40
3.5	MOLECULAR BIOLOGY	41
3.5.1	RNA extraction from <i>Spodoptera exigua</i> for sodium channel amplification	41
3.5.2	Synthesis of first-strand cDNA of <i>Spodoptera exigua</i> strains	42
3.5.3	Polymerase chain reaction (PCR)	42
3.5.4	Cloning and sequencing of sodium channel from <i>Spodoptera exigua</i>	44
3.5.5	Pyrosequencing.....	44
3.5.5.1	The principle of pyrosequencing	44
3.5.5.2	Pyrosequencing	45
3.6	STATISTICS AND CALCULATIONS	47

4	RESULTS	48
4.1	BIOASSAYS	48
4.1.1	Baseline susceptibility of <i>H. armigera</i> and <i>H. virescens</i> to different insecticides.....	48
4.1.2	Resistance pattern in <i>Spodoptera exigua</i> strain SPOD-EX E-98.....	50
4.2	EFFICACY OF FLUBENDIAMIDE	54
4.2.1	Baseline susceptibility and stage-specific activity.....	54
4.2.2	Worldwide monitoring	55
4.3	APPLICATION AND SYNERGISM STUDIES	58
4.4	BIOCHEMICAL ASSAYS	59
4.4.1	Glutathione S-transferases	60
4.4.1.1	Photometric assay in larvae mass homogenates	60
4.4.1.2	Frequency distribution of enzyme activity of single larvae	60
4.4.1.3	Fluorometric assay with monochlorobimane	61
4.4.2	Carboxylesterases	62
4.4.2.1	Standard assay in larvae mass homogenates	62
4.4.2.2	Frequency distribution of enzyme activity of single larvae	63
4.4.2.3	Carboxylesterase iso-enzyme analysis and inhibition visualised by nPAGE	64
4.4.3	Cytochrome P ₄₅₀ -dependent monooxygenases	67
4.4.3.1	Fluorometric assay with 7-ethoxycoumarin in second-instar larvae	67
4.4.3.2	Monooxygenase activity in isolated guts of fifth-instar larvae	68
4.4.4	Acetylcholinesterases	69
4.4.4.1	Standard assay in larvae mass homogenates	69
4.4.4.2	Frequency distribution of enzyme activity of single larvae	70
4.4.4.3	Michaelis-Menten kinetics	71
4.4.4.4	Acetylcholinesterase inhibition studies <i>in vitro</i>	72
4.4.5	Partial purification of acetylcholinesterases	73
4.4.5.1	Michaelis-Menten kinetics	75
4.4.5.2	Inhibition studies with purified acetylcholinesterases	75
4.4.5.3	SDS-PAGE	76
4.5	MOLECULAR BIOLOGY	77
4.5.1	Cloning and sequencing of sodium channel from <i>Spodoptera exigua</i>	77
4.5.2	Pyrosequencing.....	80
4.6	PHARMACOKINETIC STUDIES IN <i>SPODOPTERA EXIGUA</i>	82
5	DISCUSSION	86
5.1	BIOASSAYS	86
5.1.1	Endosulfan resistance	86
5.1.2	Indoxacarb resistance	87

5.1.3	Carbamate and organophosphate resistance	88
5.1.4	Benzoylphenyl urea resistance	88
5.1.5	Pyrethroid resistance.....	90
5.2	MOLECULAR ASPECTS OF PYRETHROID RESISTANCE	91
5.3	PHARMACOKINETIC STUDIES	93
5.4	BIOCHEMICAL STUDIES OF INSECTICIDE DETOXIFICATION ENZYMES	95
5.4.1	Glutathione S-transferases	95
5.4.2	Carboxylesterases	96
5.4.3	Cytochrome P ₄₅₀ -dependent monooxygenases	97
5.4.4	Acetylcholinesterases	100
5.5	ESTABLISHMENT OF A BIOASSAY-KIT FOR A WORLDWIDE MONITORING	103
5.6	RESISTANCE RISK ASSESSMENT OF FLUBENDIAMIDE	104
6	SUMMARY	107
7	ZUSAMMENFASSUNG	110
8	REFERENCES	113
9	APPENDICES	125

ABBREVIATIONS

AChE	Acetylcholinesterase
a.i.	Active ingredient
ATChI	Acetylthiocholine iodide
BPU	Benzoylphenyl urea
Bq	Becquerel (radioactive disintegrations per second)
BSA	Bovine serum albumine
CDNB	1-Chloro-2,4-dinitrobenzene
CE	Carboxylesterase
Ci	Curie is a former unit of radioactivity (1 Ci = 37 GBq)
CI 95%	Confidence interval 95%
DEF	S,S,S-Tributyl-phosphorotrithioate
dpm	Disintegrations per minute
DTNB	Dithionitrobenzoate
DTT	Dithiothreitol
Emulsifer W	Alcylarylpolyglycoether
EC	Emulsion concentrate
EC _{50/95/99}	Efficacy concentration of a pesticide expected to kill or showing symptoms of 50/95/99% of the test organisms
ED ₅₀	Efficacy dose of a pesticide expected to kill or showing symptoms of 50% of the test organisms
EDTA	Ethylenediaminetetraacetic acid
GABA	γ -Aminobutyric acid
GSH	Glutathione, reduced form
GST	Glutathione S-transferase
HELI-AR	<i>Helicoverpa armigera</i>
HELI-VI	<i>Heliothis virescens</i>
IC ₅₀	Inhibitor concentration that results in 50% inhibition of enzyme activity
IF	Insensitivity factor
IPM	Integrated Pest Management
IRM	Insecticide Resistance Management
IRAC	Insecticide Resistance Action Committee
<i>kdr</i>	Knockdown resistance

K_m	Michaelis-Menten constant
LSC	Liquid scintillation counting
n	Number of replicates
NADPH	Nicotinamide adenine dinucleotide phosphate, reduced form
nPAGE	Native polyacrylamide gel electrophoresis
OD	Optical density
OPs	Organophosphates
MAC	Moulting accelerating compound
MACE	Modified acetylcholinesterase
MCB	Monochlorobimane
Monooxygenases	Cytochrome P ₄₅₀ -dependent monooxygenase, also called mixed function oxidase (MFO)
PCR	Polymerase chain reaction
PBO	Piperonyl butoxide
<i>Rdl</i>	Resistance to dieldrin
RF	Resistance factor
r.h.	Relative humidity
R_m	Relative (electrophoretic) mobility
RT	Room temperature
SD	Standard deviation
SE	Standard error
SF	Synergistic factor
SNP	Single-nucleotide polymorphism
SPOD-EX	<i>Spodoptera exigua</i>
TX ₁₀₀	Triton X-100
vgSCh	Voltage-gated sodium channel
V_{max}	Maximum velocity

1 INTRODUCTION

1.1 Biology Lepidoptera: Noctuidae

The 30 orders of Insecta are containing five “major” orders, standing out for their fascinating variability and resulting into high species richness. One of these is the major order Lepidoptera, also known as butterflies and moths, with nearly 150,000 described species (Gullan and Cranston, 2005).

Within the Lepidoptera the family of the Noctuidae (Cutworm and owlet moths) is the species-richest, including several really important phytophagous pest species for example *Spodoptera exigua*, *Helicoverpa armigera* and *Heliothis virescens* (Table 1) (Hoffmann *et al.*, 1994).

Table 1: Taxonomic details of *Spodoptera exigua*, *Helicoverpa armigera* and *Heliothis virescens*

Phylum	Arthropoda		
Superclass	Hexapoda		
Class	Insecta		
Subclass	Pterygota		
Superorder	Endopterygota (Holometabola)		
Order	Lepidoptera		
Family	Noctuidae		
Genera	<i>Spodoptera</i>	<i>Helicoverpa</i>	<i>Heliothis</i>
Species	<i>exigua</i> (Hübner, 1808)	<i>armigera</i> (Hübner, 1808)	<i>virescens</i> (Fabricius, 1777)
Common name	Beet armyworm	Cotton bollworm	Tobacco budworm

Noctuid species are herbivorous and holometabolous insects, running through a complete metamorphosis and thus a radical change from wingless immatures (larvae) to winged adults (imagines), interrupted by a quiescent pupal stage (Gullan and Cranston, 2005; Hoffmann *et al.*, 1994).

The evolution of “holometaboly” allows the larvae and adults of an insect to use two very different feeding habits. Immature stages causing feeding damage mainly on leaves or sometimes on fruits or roots. On the other hand, adults prefer to feed on nutritious liquids, such as nectar and honeydew using permanent tubelike sucking mouthparts (Evans, 1984).

The adult stage shows a robust body and wings with dingy colours, and has the reproductive role. After a sexual mating, the female deposits the mature eggs, and the embryonic phase (egg stage) begins (Evans, 1984; Gullan and Cranston, 2005).

The first instar of a larva starts by hatching from the egg. The further development of the immature (juvenile) insect is characterised by repeated moults separated by periods of intensive feeding (Gullan and Cranston, 2005). The periodic formation of a new cuticle and subsequent shedding the old (too small) cuticle is called moulting process, followed by scleroziation of the new skin.

Typically, lepidopteran larvae are characterised by a polypod, cylindrical body shape with short thoracic legs and abdominal prolegs (pseudopods) and biting mouthparts. After a determined number of larval instars (usually 4 to 6) a resting stage - called pupa - followed. Only holometabolous insects run through a pupal stage. During this pupal stage adult structures are formed. The pupal stage ends with the eclosion of the adult (Gullan and Cranston, 2005).

1.2 *Spodoptera exigua*, *Helicoverpa armigera* and *Heliothis virescens*

The work carried out in this thesis focuses on three species of the family Noctuidae, i.e. *S. exigua*, *H. armigera* and *H. virescens* (Table 1). All the experimental work was done by using larvae (immature stage), since they are responsible for significant feeding damage and yield losses in different agronomic cropping systems. The species mentioned above go through five moulting cycles during larval development, resulting in five larval instars (Figure 1).

Figure 1: Pictures of larval stages of lepidopteran larvae used throughout the study: **A.** *Spodoptera exigua*; **B.** *Helicoverpa armigera*; **C.** *Heliothis virescens*

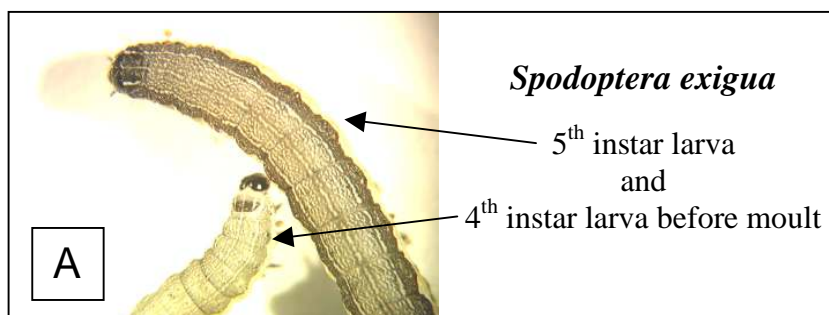

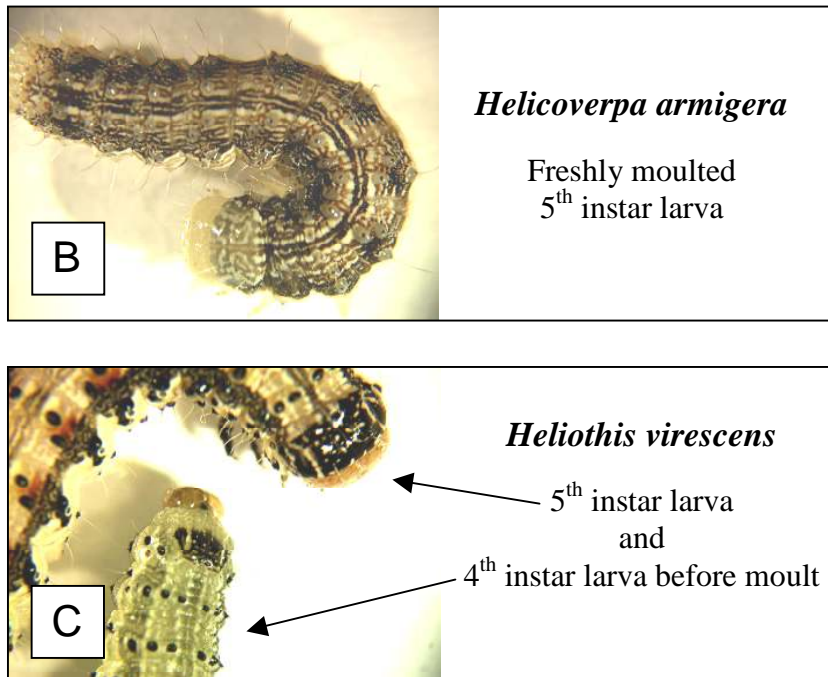

All three species are well-known as important insect pests in many agricultural systems worldwide. *S. exigua* is of economic importance for example on cotton, tomato, celery, lettuce, cabbage and alfalfa. *H. armigera* causes damage on cotton, corn, sorghum and tomato, and *H. virescens* is a major pest on chickpea, corn, cotton and tobacco (www.pesticideresistance.org).

1.3 Lepidopteran species – important insecticides

1.3.1 History – Development of the lepidopteran insecticide market

The early history of insect pest control has consisted of the combination of different methods such as the use of sulphur, chalk, wood ash and plant extracts. In the 19th century, botanical compounds (e.g. pyrethrum, quassia) have been introduced into the market; sulphur, arsenic, fluorides, soaps and kerosene were used additionally to combat insect plagues (Ishaaya, 2001; Gullan and Cranston, 2005).

The rational development of synthetic insecticides has started during World War II; the progress came through the development of cheap and effective chemical insecticides (Gullan and Cranston, 2005). The time of the insecticide boom was supported by the synthesis of new chemicals and standardization of screening techniques and bioassays, resulting in the discovery of various structures with biological activity against pest insects. In the 1950s to 1970s, synthetic organic insecticides, such as cyclodienes, organophosphates and carbamates,

have been developed and led to their widespread use as commercial compounds for controlling many agricultural pests (Ishaaya, 2001; Nauen and Bretschneider, 2002).

Unfortunately, many of these chemicals are harmful to mammals, beneficial arthropods or to the environment in general. The introduction of the pyrethroids in the 1970s led to the replacement of further dangerous and environmentally less suitable compounds (Elliott *et al.*, 1978; McCaffery, 1999).

For at least three decades it was screened for compounds that are acting only on insects. Efforts made during this time and lead to the development of safe and novel insecticides. One example is the group of benzoylphenyl ureas, specifically effecting chitin formation in insect cuticles (Ishaaya, 2001).

New compounds must meet higher standards, such as new modes of action combined with less resistance risk, environmentally safe and selective control. The introduction of new classes of insecticide chemistry such as uncouplers, oxadiazines, diacylhydrazines or compounds originating from natural products (spinosyns, avermectins) should give new possibilities to control lepidopteran pests in the future and release selection on existing resistance mechanisms (McCaffery, 1999; Ishaaya, 2001).

1.3.2 General overview of the world market for insecticides

The world insecticide market can roughly be divided into six invertebrate pest orders (Figure 2). The order Lepidoptera (38%) is the economically most important invertebrate pest order worldwide, including the widespread and polyphagous family of Noctuidae - additionally see section 1.1. The order Hemiptera (e.g. aphids) is ranking second, followed by Coleoptera (e.g. leaf beetles), Acari (e.g. spider mites), Nematoda (e.g. cyst nematodes) and Diptera (e.g. mosquitos). Pest orders below 3% of the total insecticide market are not considered in Figure 2, such as the order Thysanoptera or Orthoptera.

Figure 2: Distribution of invertebrate pest orders by economic value. (Those orders mentioned here account for 84% of the total market, including nematicides and acaricides). Data taken from Nauen (2002).

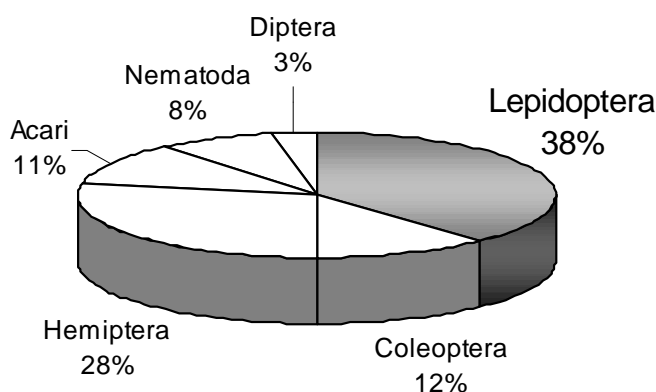

Synthetic insecticides have been developed and used to control insect pest over the last six decades, minimizing yield losses in agricultural systems. The agrochemical industry has made many efforts during this time to develop novel insecticides with better environmental, toxicological and selective properties resulting in safe and efficient insect control agents. The insect nervous system is a critical target for chemical attack; it plays an essential regulatory role that dictates the physiology and behaviour of the whole organism within a very short time upon innervation. Therefore, it is not surprising that the chemical control of insect pests has primarily aimed at affecting neuronal target-sites; thus neurotoxic compounds now dominate the insecticide market (>85% of the total market in 2005; McCaffery and Nauen, 2006).

The world market for insecticides is controlled by four major targets (Table 2), all located in the nervous system. Acetylcholinesterase is still the number one target, inhibited by the chemicals classes of organophosphates and carbamates, but decreased from 71% market share in 1987 to 51% in 1999, and less than 45% in 2005 (McCaffery and Nauen, 2006). This target combined with the voltage-gated sodium channel, the nicotinic acetylcholine receptor and the GABA-gated chloride channel include the vast majority of insecticide production (90.3% in 1999), such as the pyrethroids, neonicotinoids, fiproles and cyclodienes. Another group of compounds (non-neuronal) affect the hormonal regulation of moulting and developmental processes in insects in general, such as ecdysone agonists and chitin biosynthesis inhibitors. These insecticides are very specific, but slow acting and therefore not very popular in comparison to neurotoxic compounds.

Table 2: Mode of action of the top-selling 100 insecticides/acaricides and their world market share (excluding fumigants, endotoxins and those insecticides with unknown mode of action). Table taken from Nauen and Bretschneider (2002).

Mode of action	1987 %	1999 %	Change %
Acetylcholinesterase	71.0	52.0	- 20.0
Voltage-gated sodium channel	17.0	18.0	+ 1.4
Acetylcholine receptor	1.5	12.0	+ 10.0
GABA-gated chloride channel	5.0	8.3	+ 3.3
Chitin biosynthesis	2.1	3.0	+ 0.9
NADH dehydrogenase	0	1.2	+ 1.2
Uncouplers	0	0.7	+ 0.7
Octopamine receptor	0.5	0.6	+ 0.1
Ecdysone receptor	0	0.4	+ 0.4

1.3.3 “Old Chemistry”

1.3.3.1 Pyrethroids

The synthetic pyrethroid insecticides are derived from the structure of the natural pyrethrins, which were isolated from the flower heads of the genus *Pyrethrum* (*Chrysanthemum*). Natural pyrethrins are unstable, sensitive to photodegradation and relatively expensive, facts resulting in trails to modify their chemical structure in order to make them more potent and stable under open-field conditions. Subsequently, new synthetic analogues were prepared exhibiting high efficacy, good photostability and residual activity. As broad-spectrum insecticides, they are effective against adult, larval, and egg stages of Lepidoptera, but also of many Coleoptera, Diptera, Homoptera and Heteroptera pest species (Elliott *et al.*, 1974; Elliott *et al.*, 1978).

Pyrethroids are divided in Type I or Type II compounds based on their chemical structure and distinct symptomology of poisoning (Gammon *et al.*, 1981; Vais *et al.*, 2001). Pyrethroids of Type I lack a cyano moiety in the α -carbon position, which is present at the phenylbenzyl alcohol position of Type II pyrethroids. Type I pyrethroids (e.g. permethrin; Figure 3)

poisoning induce hyperactivity and uncoordinated movement caused through repetitive firing and multiple-spike discharges in response to a single stimulus. Type II pyrethroids (e.g. deltamethrin; Figure 3) induce nerve depolarization in the central nervous system, loss of electrical excitability and subsequently paralysis of the insect (Gammon *et al.*, 1981; Bloomquist, 1993; Dong, 2007).

Generally, both types show a high speed of action, which leads to rapid “knock-down” symptoms in insects. The pyrethroids, as an important class of insecticides, interact with voltage-gated sodium channels (vgSChs) in nerve axons. The rapidly depolarizing phase and propagation of action potentials in many excitable cells due to rapid increase in sodium conductance is mediated by vgSChs. Pyrethroids alter the gating kinetics of the vgSCh and so cause a prolonged opening of the channel by inhibition of the channel deactivation and stabilisation of the open channel configuration (open channel block). The results are hyperexcitability, bursts of action potentials, nerve blockage and finally exodus (Bloomquist, 1993; Narahashi, 2000; Zlotkin, 2001; Nauen and Bretschneider, 2002; Dong, 2007).

Figure 3: Type I pyrethroid permethrin (left) and Type II pyrethroid deltamethrin (right)

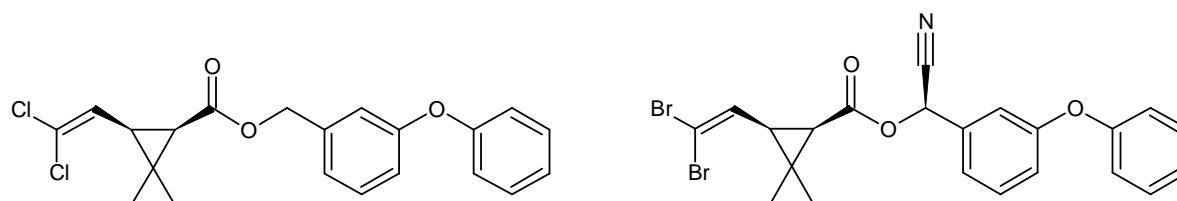

1.3.3.2 Carbamates and organophosphates

Carbamates and organophosphates (OPs) are still two very important chemical insecticide classes. OPs were introduced to the agrochemical market over 60 years ago, first in 1944, followed by carbamates in the early 50s.

These so-called broad-spectrum insecticides are still a big player on the world market for insecticides and active against a wide range of insect orders, but showing a high toxicity to non-target organisms including mammals (Siegfried and Scharf, 2001; Nauen and Bretschneider, 2002).

OPs (Figure 5) are sharing the same mode of action with the carbamates (Figure 4). Both chemical groups inhibit competitively the important enzyme acetylcholinesterase (AChE) in the central nervous system, and their molecular interactions are analogous to that of the substrate acetylcholine (Fournier and Mutero, 1994).

AChE is responsible for hydrolysing the excitatory neurotransmitter acetylcholine at the nerve synapses. Inhibition of the AChE leads to an accumulation of acetylcholine in the synaptic cleft and hyperexcitation of the central nervous system occurs. The signs of intoxication include tremors, convulsions, and paralysis of the insect. Finally, it results in a repetitive firing of neurones and ultimately death by exhaustion (Gunning and Moores, 2001; Siegfried and Scharf, 2001).

Figure 4: Structures of thiodicarb (left) and carbofuran (right)

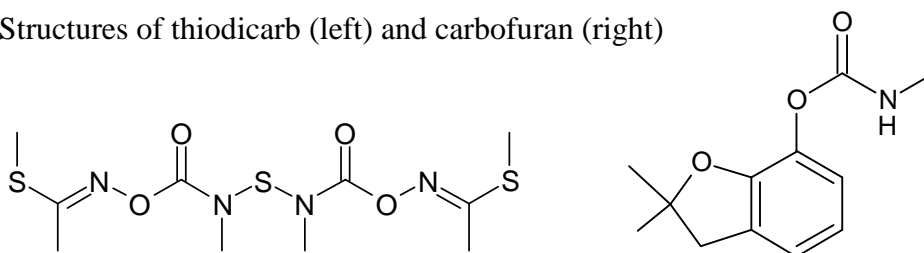
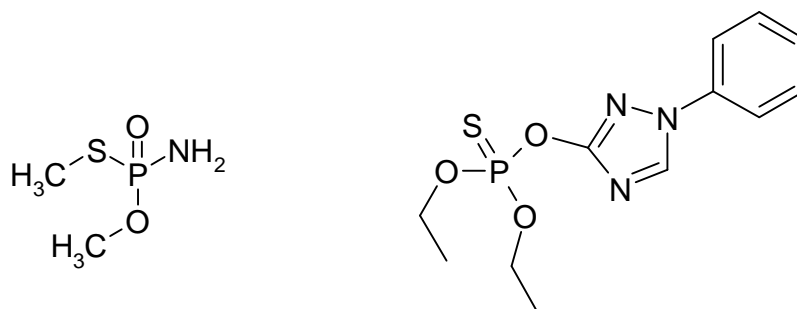

Figure 5: Structures of methamidophos (left) and triazophos (right)



1.3.3.3 Cyclodienes

The compound endosulfan (Figure 6) is a member of the old chemical class of cyclodienes and active on many insect pest species. The target-site of cyclodienes is the GABA_A-receptor of the central nervous system. The inhibitory neurotransmitter γ -aminobutyric acid (GABA) binds to the GABA-receptor in the post-synaptic membrane. The receptors are chloride channels gated by binding of the neurotransmitter. Subsequently, GABA induces chloride ion flux to cause hyperpolarisation, by which nerve excitation is suppressed (Abalis *et al.*, 1985; Ozoe and Akamatsu, 2001).

Cyclodienes act as non-competitive antagonists of GABA-receptors; they inhibit the activation of the insect GABA-receptors. Symptomology of poisoned insects is lost of coordination followed by hyperactivity, convulsions, paralysis and leg tremor (Abalis *et al.*, 1985; Nauen and Bretschneider, 2002).

Figure 6: Structure of endosulfan

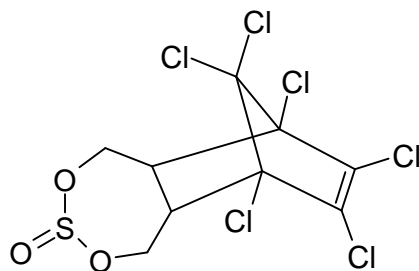

1.3.3.4 Benzoylphenyl ureas

This class of compounds is known to inhibit chitin biosynthesis and is often grouped together within the insect growth regulators (IGRs). Generally, the function of IGRs is to mimic the action of hormones, resulting in an incomplete moulting process, as described for the compound fenoxycarb (Nauen and Bretschneider, 2002).

However, benzoylphenyl ureas (BPUs) are not hormone-associated compounds; they inhibit chitin production. The exact mode of action of benzoylphenyl ureas is still under investigation, but the reduced level of chitin in the cuticle seems a result from inhibition of biochemical processes leading to chitin formation. Chitin is a major component of the insect exoskeleton, and builds up of N-acetylglucosamine monomers. Insects poisoned with BPUs are unable to synthesize a new stable cuticle, and thereby stopping the larva from a successful moult into the next stage (Ishaaya, 2001).

BPU insecticides like triflumuron and hexaflumuron (Figure 7) are rather specific insecticides acting against lepidopterans and show a very low vertebrate toxicity. In contrast to neuronally acting compounds the BPUs much slower in achieving full efficacy against pest insects (Nauen and Bretschneider, 2002).

Figure 7: Structures of triflumuron (left) and hexaflumuron (right)

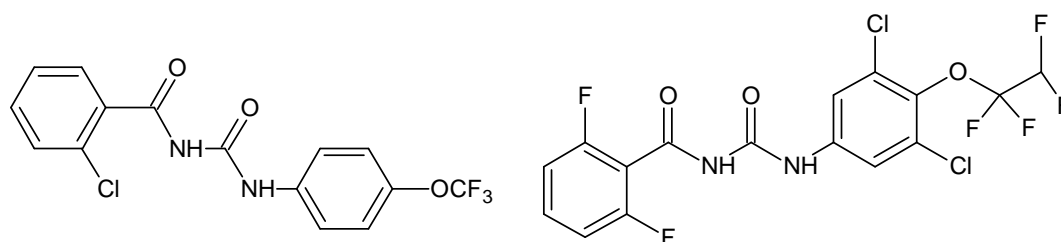

1.3.4 “New Chemistry”

1.3.4.1 Indoxacarb

A novel insecticidal compound interacting with the voltage-gated sodium channel (vgSCh) is indoxacarb, a new oxadiazine insecticide. It is especially effective against a broad-spectrum of lepidopteran larvae. Indoxacarb is a highly potent blocker of sodium channels, by binding selectively to the slow-inactivated state. Nevertheless, indoxacarb acts on a binding site different from pyrethroids and no cross-resistance between these classes is described so far (Wing *et al.*, 1998; Nauen and Bretschneider, 2002).

Indoxacarb is a pro-insecticide (Figure 8) with only weak activity on vgSCh, which is rapidly bioactivated by target insects. Metabolic activation through esterases is resulting in an NH-derivative (DCJW) with potent insecticidal activity (Wing *et al.*, 1998).

Figure 8: Structure of indoxacarb

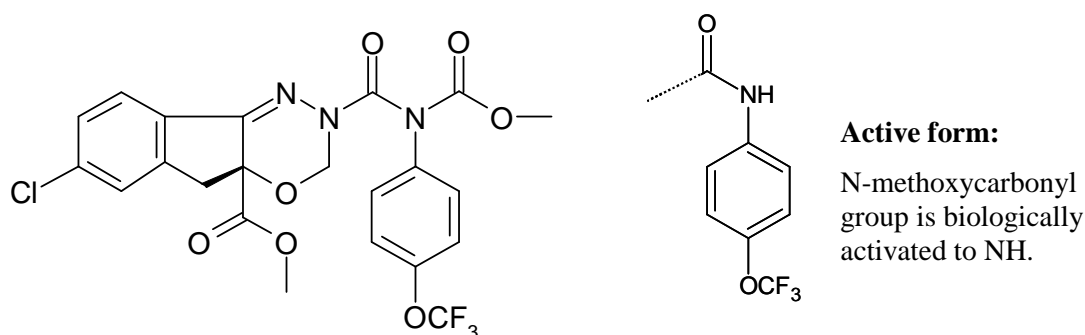

1.3.4.2 Emamectin

The avermectins are a group of macrocyclic lactones produced by the soil actinomycete *Streptomyces avermitilis*, the major compound is avermectin. The group has very potent compounds with excellent acaricidal and anthelmintic and less insecticidal properties (Argentine *et al.*, 2002; Nauen and Bretschneider, 2002).

The semi-synthetic derivative, emamectin (Figure 9), where the hydroxy group in the terminal sugar ring is replaced by a methylamino group shows an excellent lepidoptericide activity compared with the parent compound abamectin (Bloomquist, 2001; Nauen and Bretschneider, 2002). Macrocyclic lactones are produced by large-scale fermentation of the bacterial strains synthesizing these compounds naturally, resulting in a high price product (Jansson and Dybas, 1998).

Abamectin and all semi-synthetic derivatives exhibit the same mode of action, as agonists of neurotransmitter (GABA and glutamate)-gated chloride channels. They act in the insect

nervous system, resulting in strong chloride ion influx into the cells followed by disruption of nerve impulses, paralysis and finally death (Nauen and Bretschneider, 2002).

Figure 9: Structure of emamectin

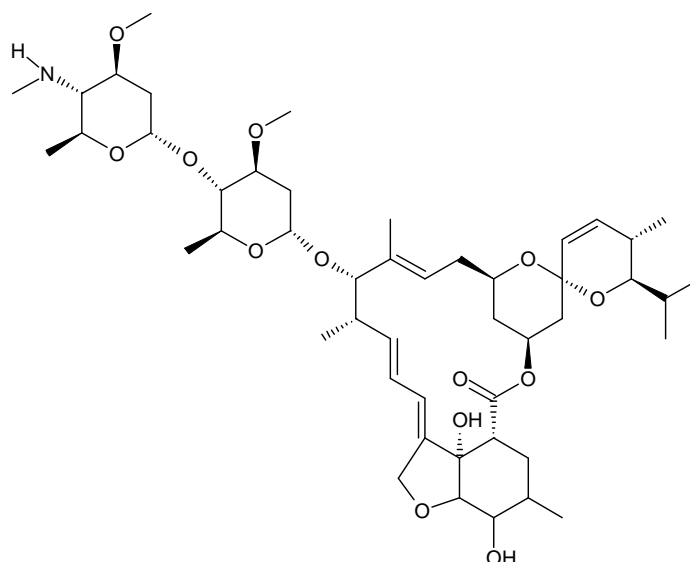

1.3.4.3 Spinosad

The natural product spinosad (Figure 10) was isolated from cultures of the soil microorganism *Saccharopolyspora spinosa*. The compound spinosad is in reality a mixture of two macrocyclic lactones spinosyn A (85%) and spinosyn D (15%). This mixture is particularly effective against pests in the lepidopteran family Noctuidae (Thompson and Hutchins, 1999; Nauen and Bretschneider, 2002).

Typical symptoms of spinosyn poisoning are excitation of the insect nervous system, leading to involuntary muscle contractions, prostration with tremors, and paralysis. The mode of action is the activation of nicotinic acetylcholine receptors (nAChRs) and prolongation of acetylcholine responses (Thompson and Hutchins, 1999; Nauen and Bretschneider, 2002). Spinosad acts at a different binding site on the nAChR than other insecticides like neonicotinoids (Thompson and Hutchins, 1999).

Figure 10: Structures of spinosyn A (left) and spinosyn D (right)

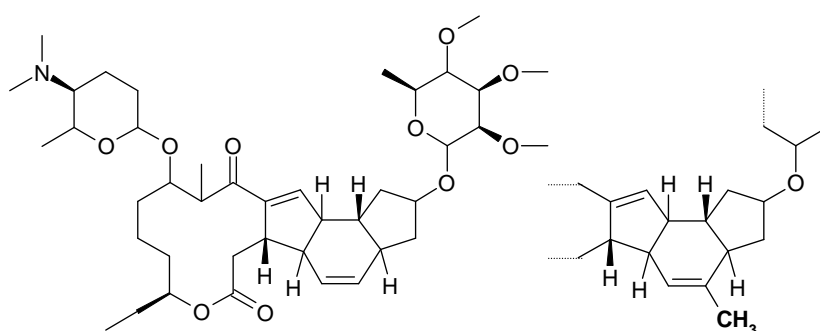

1.3.4.4 Chlorfenapyr

Chlorfenapyr is an aryl-substituted cyanopyrrole and shows a broad-spectrum of activity against insects and mites. Synthetic modification of dioxapyrrolomycin, a natural product isolated from *Streptomyces fumanus*, led to the discovery of chlorfenapyr by the American Cyanamid Company (Treacy *et al.*, 1994).

Chlorfenapyr is a pro-insecticide (Figure 11) which is activated metabolically by N-dealkylation i.e. oxidative removal of the N-ethoxymethyl group (Black *et al.*, 1994). Once converted to its “active” form chlorfenapyr uncouples the oxidative phosphorylation and the pyrrole disrupts the proton gradient across mitochondrial membrane. Thus, the vital energy-production process that converts ADP to ATP is inhibited and finally leading to cell and organism death (Nauen and Bretschneider, 2002; Treacy *et al.*, 1994).

Figure 11: Structure of chlorfenapyr (AC-303630)

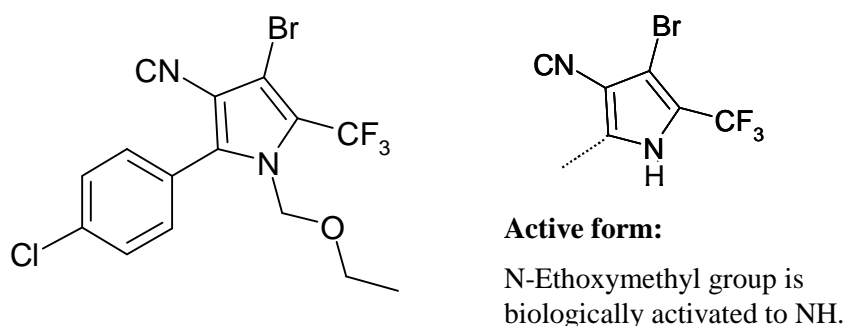

1.3.4.5 Moulting accelerating compounds (diacylhydrazines)

In the early 1990s, tebufenozide opens the new class of moulting accelerating compounds (MACs) chemically described as diacylhydrazines. Methoxyfenozide (Figure 12) is the newest and most efficacious member of the chemical diacylhydrazine class, and acts against a range of economically important lepidopteran larvae. Two more compounds of this chemical class, halofenozide and chromafenozide, have recently been introduced, but with limited success. The four ecdysteroid agonists (except halofenozide) are more or less lepidopteran-selective insecticides (Carlson *et al.*, 2001; Nauen and Bretschneider, 2001).

Mode of action-wise MACs are potent non-steroidal ecdysone agonists, i.e. they mimic the insect moulting hormone, 20-hydroxyecdysone (20E), which plays a central role in the regulation of the growth and development process (Carlson *et al.*, 2001).

MACs induce a precocious moult and head capsule slippage, which leads to feeding inhibition and loss of weight. The larvae remain moribund at this stage and die of starvation and dehydration (Nauen and Bretschneider, 2001; Palli and Retnakaran, 2001).

Figure 12: Structure of methoxyfenozide (RH-2485)

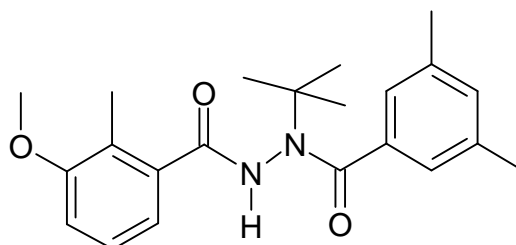

1.3.4.6 Flubendiamide

Flubendiamide (NNI-0001) is a new insecticide and globally co-developed by Nihon Nohyaku Co., Ltd. and Bayer CropScience AG. The parent structure of flubendiamide was originally discovered by Nihon Nohyaku during a herbicide program on pyrazinedicarboxamides in 1993, and the discovery of more potent substituents led to the synthesis of the insecticide flubendiamide in 1998 (Tsubata *et al.*, 2007).

The public introduction of the new compound flubendiamide was in July 2005 (Nishimatsu *et al.*, 2005) and the first registration was obtained in the Philippines in 2006, followed by Japan, Pakistan, Chile, India and Thailand in 2007. Further registrations are expected all over the world during this year, the new product will be sold under the trade names Amoli[®], Belt[®], Fame[®], Fenos[®], Phoenix[®] and Takumi[®] (Hirooka *et al.*, 2007).

Flubendiamide (Figure 13) is a novel class insecticide of the chemical family of 1,2-benzenedicarboxamides or phthalic acid diamides. Flubendiamide acts by selective activation of the ryanodine receptor (RyR) in insects, inducing ryanodine-sensitive cytosolic Ca²⁺ transients independent of the extracellular Ca²⁺ concentration (Ebbinghaus-Kintscher *et al.*, 2005 and 2007; Nauen, 2006).

The ryanodine-sensitive intracellular Ca²⁺ release channels (commonly called ryanodine receptors) are located intracellular. The function of these specialized channels is the rapid and massive release of Ca²⁺ from intracellular stores, which is necessary for contraction of muscles. In the case of flubendiamide, the compound disrupted the calcium regulation by an allosteric mechanism (Ebbinghaus-Kintscher *et al.*, 2005).

Since decades a natural product ryanodine is known, which also acts on the ryanodine receptor and exhibits insecticidal activity. The plant-derived alkaloid ryanodine or their

semi-synthetic derivatives have shown weak insecticidal properties under field conditions, so they are without economical importance on the insecticide market (Jefferies *et al.*, 1997).

Figure 13: Structure of flubendiamide (NNI-0001)

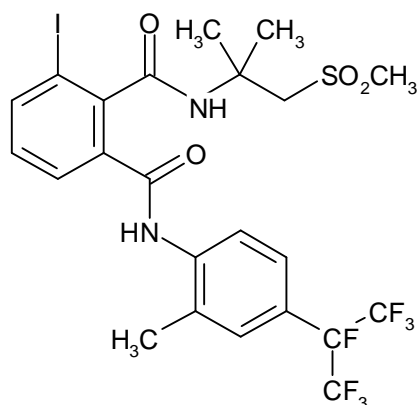

1.3.4.7 Flubendiamide a new tool on the insecticide market

Flubendiamide is the first representative of a new chemical option for pest control belonging to a novel class of insecticides, named benzenedicarboxamides or phthalic acid diamides (Nauen, 2006). The chemical structure of flubendiamide is unique for insecticides and contained three characteristic parts: a phthaloyl moiety, an aromatic amide moiety and an aliphatic amide moiety (Tsubata *et al.*, 2007).

The new insecticide is extremely effective especially against a broad-spectrum of lepidopteran pest species and shows an outstanding larvicidal activity (Tohnishi *et al.*, 2005; Nauen, 2006; Hirooka *et al.*, 2007). After flubendiamide treatment, lepidopteran larvae show a unique symptomology of poisoning: the body control is lost and a complete and irreversible contraction including a feeding stop occurs.

Flubendiamide is classified as the first member of the new group 28 (ryanodine receptor modulator) within the IRAC (Insecticide Resistance Action Committee) mode of action classification scheme (Nauen *et al.*, 2007). The IRAC classification scheme was introduced to provide guidance for designing suitable resistance management strategies, i.e. those compounds belonging to different groups can be alternated in order to delay or avoid rapid development of resistance in treated pest insects (www.ircac-online.org).

The potent activation of ryanodine receptors results in a fast initial efficacy in the insect, and no cross-resistance to currently available insecticides yet detected (Nauen *et al.*, 2007). Additionally, flubendiamide shows an excellent biological and ecological profile (Hall, 2007; Hirooka *et al.*, 2007).

Consequently, flubendiamide will be an excellent tool for controlling lepidopteran insects as a part of insect resistance management and integrated pest management programs as suggested by Nauen *et al.* (2007).

Additionally, it has been shown that phthalic acid diamides are specifically active on ryanodine receptors in insects and that they have no effect on mammalian ryanodine receptors, resulting in a favourable toxicological profile of flubendiamide (Ebbinghaus-Kintscher *et al.*, 2005).

1.4 Resistance

One important problem in agriculture is the development of pest resistance to pesticides with a great practical and economic significance for growers and industry worldwide. Resistance is defined by the World Health Organization (WHO) as the “development of an ability in a strain of an organism to tolerate doses of toxicant which would prove lethal to the majority of individuals in a normal population of the species” (World Health Organization, 1957). Another definition is given by Insecticide Resistance Action Committee (IRAC - www.irc-online.org) they defined insecticide resistance as “a heritable change in the sensitivity of a pest population that is reflected in the repeated failure of a product to achieve the expected level of control when used according to the label recommendation for that pest species”.

Resistance development is usually a consequence of natural selection; an insecticide prevents susceptible individual insects from reproducing leaving only those individuals carrying the genes for resistance. The chance of a resistance case arises considerably through the misuse or overuse of insecticides against pest populations, and results in the survival of resistant individuals and faster evolution of resistant populations.

Actually, insecticide resistance is documented in many arthropod pest species, and is one of the major problems for the control of agriculturally and medically important pests (Zlotkin, 2001). Before the 20th century only anecdotal cases of resistance in arthropod pest species were recorded. The first well-documented case of insecticide resistance was reported in 1908 (Forgash, 1984). Since the first report, the number of resistant arthropod pest species is increased significantly (Figure 14). The origin of the data combined information of Georghiou and Lagunes-Tejeda (1991) and records in the “Arthropod Pesticide Resistance Database” (APRD - www.pesticideresistance.org).

Figure 14: Chronological development of resistance cases of insects and mites over the last six decades. Graph taken from Gullan and Cranston (2005).

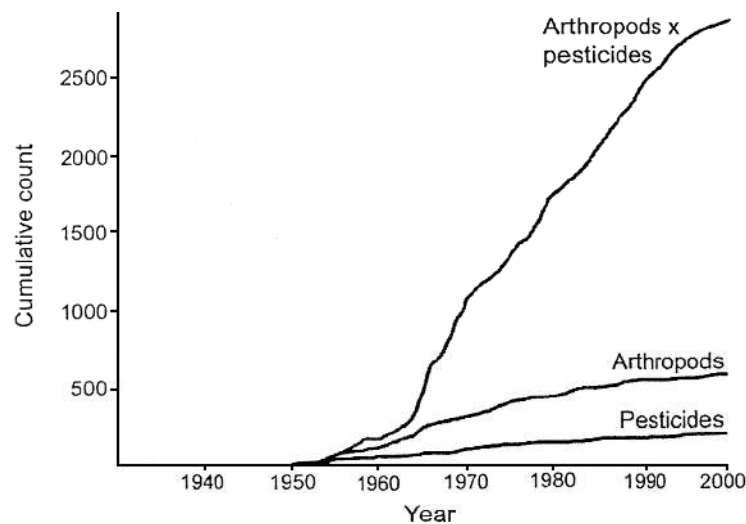

Initially between 1908 and the mid-1950s the number of resistant arthropod pest species grew slowly, but then increased greatly in number (approx. 15 new resistant species per year) due to the widespread use of synthetic insecticides. Today more than 500 arthropod pest species are known to be resistant to at least one insecticide or acaricide (Gullan and Cranston, 2005) and more than 2,600 single cases are detected were an arthropod species was resistant to one or more pesticides (APRD).

Especially for pest lepidopterans many incidences of resistance cases were reported so far, e.g. 70, 113 and 468 resistance cases for the species *S. exigua*, *H. virescens* and *H. armigera*, respectively (APRD).

1.5 Overview of resistance mechanisms in insects

There are several ways that agricultural pests can express resistance to insecticides. The intoxication of an insect by an insecticide comprises four levels of pharmacological interaction: behavioural modification, reduced penetration or absorption of the toxicant, biochemical detoxification mediated by specialized enzymes and finally a reduction in the sensitivity of the target-site (Feyereisen, 1995; Soderlund, 1997). In reality, the major mechanisms of insecticide resistance are enzyme-based detoxification and mutation within the target-site (Hemingway *et al.*, 1999).

It is possible that pest species develop more than one of these mechanisms at the same time or the mechanism acts (e.g. biochemical metabolism) on more than one group of insecticides, and resulting in a cross-resistance.

1.5.1 Penetration and behavioural resistance

Physiological changes are basic reasons of the penetration resistance phenomena. One way is that the resistant insect may absorb the toxin slower as a susceptible individual, caused through an altered composition of waxes in the cuticle. The other ways of physiological detoxification are the sequestration or accelerated excretion of the insecticide (Gullan and Cranston, 2005). In some cases, the insect detects or recognizes the insecticide (e.g. neem) and avoid the toxin, called repellent-effect (Gullan and Cranston, 2005).

These resistance mechanisms are least important; they usually are present along with other forms of resistance and contribute to higher resistance levels (reduced susceptibility).

1.5.2 Metabolic resistance

A more common mechanism of resistance is the biochemical detoxification of chemical compounds (also called metabolic resistance) mediated by specialized enzymes and leading to the formation of less toxic metabolites.

Three enzyme systems, microsomal cytochrome P₄₅₀-dependent monooxygenases, esterases, and glutathione S-transferases, are commonly involved in the detoxification of a wide range of insecticides. Increased metabolism can result from modification of existing enzyme forms, making them more suitable for degradation of insecticides, and on the other hand through factors leading to increased production of detoxification enzymes which in susceptible insects occur in much lower quantities (Hemingway *et al.*, 1999; Siegfried and Scharf, 2001).

1.5.2.1 Glutathione S-transferases

Glutathione S-transferases (GSTs; EC 2.5.1.18) are a family of ubiquitous, soluble (cytosolic), multi-functional and mostly dimeric enzymes. This group of enzymes is found in most aerobic microorganisms, plants and animals, including insects (Armstrong, 1991; Soderlund, 1997). GSTs catalyze conjugations by facilitating the nucleophilic attack of the sulfhydryl group of endogenous reduced glutathione (GSH) on electrophilic centers of a vast range of xenobiotic compounds (Armstrong, 1997; Figure 15).

Figure 15: Glutathione S-transferase mediated conjugation of the artificial substrate 1-chloro-2,4-dinitrobenzene with GSH

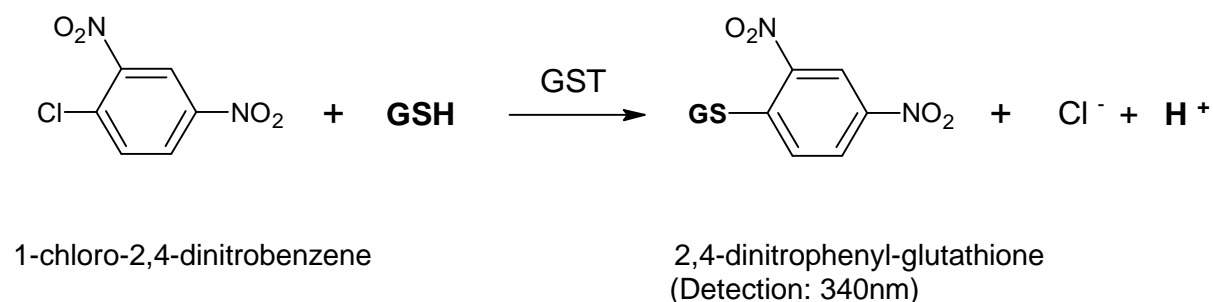

Many hydrophobic, endogenous and foreign substances (including insecticides) form with GSH more water-soluble conjugates (phase II metabolism), and so facilitate the detoxification and subsequent excretion of the substances from the organism/insect (Sun *et al.*, 2001).

GSTs were to be involved in the detoxification of several chemical classes of insecticides, i.e. organophosphates, carbamates, pyrethroids and chlorinated hydrocarbons such as DDT (Sun *et al.*, 2001). GST-based resistance to insecticides was described to be caused by the increase in the level of expression of one or more GST genes, but the molecular genetic mechanisms responsible for this up-regulation of activity has not yet been resolved in detail (Feyereisen, 1995; Hemingway, 2000).

1.5.2.2 Carboxylesterases

Carboxylesterases (CEs; EC 3.1.1.1) are important hydrolases for the detoxification of various endogenous and exogenous substances. This large family of enzymes can be characterised based on their electrophoretic mobilities or inhibitor and substrate specificities (Dauterman, 1985; Soderlund, 1997). Insect CEs play an important role in the biotransformation and detoxification of exogenous structures - like insecticides - by hydrolysing them. The detection of the CE activity is often detected using the non-insecticidal 1-naphthyl acetate as an artificial substrate in a colourmetric biochemical assay (Figure 16). In many insect species, it has been reported a correlation of higher enzyme activity and resistance to insecticides (Pasteur and Georghiou, 1989; Soderlund, 1997).

Figure 16: Hydrolysis of 1-naphthyl acetate (artificial substrate) catalysed by carboxylesterases

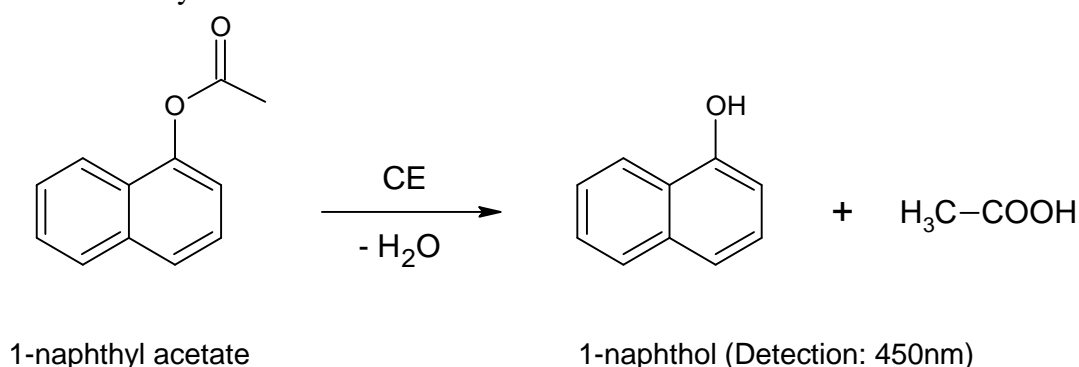

Resistance to organophosphates, carbamates and pyrethroids is conferred by an enhanced detoxification or sequestration by CEs, since most of them containing an ester moiety in their chemical structure (McCaffery, 1999; Hemingway, 2000). Esterase-based insecticide resistance mechanisms can involve gene amplification as a reason of higher CE activities in resistant pest populations (Feyereisen 1995; Soderlund, 1997; Hemingway, 2000).

1.5.2.3 Cytochrome P₄₅₀-dependent monooxygenases

Cytochrome P₄₅₀-dependent monooxygenases (monooxygenases; EC 1.14.14.1) are ubiquitous enzymes and found in all aerobic organisms, bacteria, plants, mammals, birds and insects (Bergé *et al.*, 1999; Scott, 1999). There are different terms used instead of monooxygenases, i.e. they are also known as mixed-function oxidases or polysubstrate monooxygenases. Cytochrome P₄₅₀ proteins - an important superfamily - are heme-containing proteins, named for the absorption band at 450nm of their carbon-monoxide-bound form (Werck-Reichhart and Feyereisen, 2000).

Monooxygenases catalyse a variety of oxidative reactions with a significant diversity of endogenous (e.g. steroids, hormones, fatty acids) structures or exogenous substrates such as pesticides, plant toxins and drugs (Hodgson, 1983; Scott, 2001). The general stoichiometry of the enzyme group is, $S + \text{NADPH} + \text{H}^+ + \text{O}_2 \rightarrow \text{SO} + \text{NADP}^+ + \text{H}_2\text{O}$. The catalyzed chemical reactions include hydroxylation, epoxidation, O-, N- and S-dealkylation, N- and S-oxidations and others (Bergé *et al.*, 1999; Feyereisen, 1999).

Insect monooxygenases are found in many tissues: the fat body, Malpighian tubules, and the midgut are usually a rich source of enzyme activity (Hodgson, 1983; Scott, 1999). The insect subcellular distribution of P₄₅₀ systems particularly revealed activity in microsomes (endoplasmic reticulum-bound), but it has also found in mitochondria (Hodgson, 1983; Feyereisen, 1999).

Many model substrates were widely used for the biochemical detection of the monooxygenase activity in insects, e.g. p-nitroanisole, methoxy- and ethoxyresorufin. One sensitive and rapid system is the use of 7-ethoxycoumarin (Figure 17) to measure fluorometrically monooxygenase activity via O-deethylation, especially in single insects (Bergé *et al.*, 1999).

Figure 17: Monooxygenase-mediated O-deethylation of 7-ethoxycoumarin (artificial substrate)

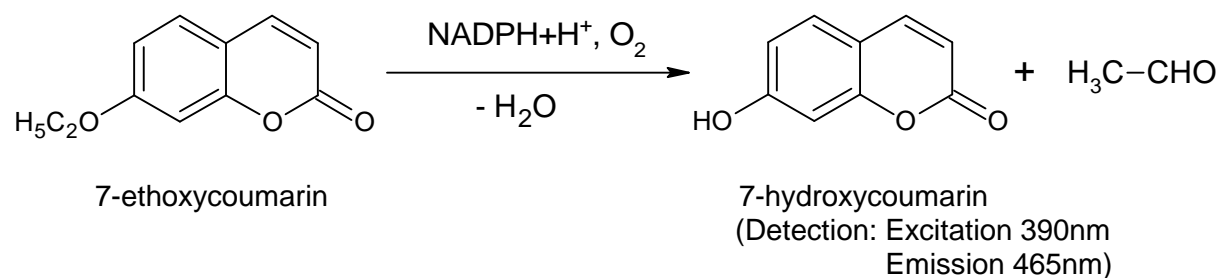

Regulatory changes appear to be involved in metabolic resistance, and in those cases monooxygenases often confer resistance to many classes of insecticides, including organophosphates, carbamates, pyrethroids and chitin biosynthesis inhibitors (Scott, 1999; Feyereisen, 1999; Siegfried and Scharf, 2001). It is common that many cases of metabolic resistance to insecticides are the result of elevated levels of monooxygenases. Polymorphisms in induction or constitutive expression allow insects to develop resistance against insecticides (Feyereisen, 1995 and 1999; Bergé *et al.*, 1999; Scott, 1999). One recent result of studies on the molecular level is that gene amplification does not appear to be involved in mechanisms for over-expression in houseflies (Scott, 1999).

1.5.3 Altered target-site resistance

The second most common resistance mechanism is altered target-site resistance. The target-site where the insecticide usually binds undergoes a genetically-based modification for example by single-nucleotide polymorphisms leading to a change in the amino acid sequence within the binding region of the target protein (Gullan and Cranston, 2005).

1.5.3.1 GABA receptor: target-site resistance to cyclodiene

Studies on molecular level have identified point mutations associated with target-site insensitivity in genes encoding insecticide targets. One example is the GABA-gated chloride channel in post-synaptic nerve membranes, the binding site of cyclodiene compounds (Feyereisen, 1995; Bloomquist, 2001). The GABA_A receptors in insects are heteromultimers,

and only a few types of subunits are identified and investigated (Bloomquist, 2001). The *Rdl* (resistance to dieldrin) subunit is well characterised, and a single common point mutation (alanine to serine at position 302) results in resistance to cyclodiene insecticides in several insect species (Feyereisen, 1995; Soderlund, 1997; Ozoe and Akamatsu, 2001). However, in two insect species a different mutation was described, resulting in an alanine to glycine replacement (Feyereisen, 1995; Bloomquist, 2001).

1.5.3.2 Insensitive AChE: target-site resistance to carbamates and organophosphates

Acetylcholinesterase (AChE; EC 3.1.1.7) is a key enzyme in the insect nervous system, terminating neurotransmission by the hydrolysis of the neurotransmitter acetylcholine.

AChE is the target-site of inhibition by organophosphate and carbamate insecticides, and if this hydrolysis does not take place, build-up of acetylcholine occurs and leads to repeated firing of neurones and ultimately death of the insect (McCaffery, 1999; Gunning and Moores, 2001).

In insects, AChE exists in one main form as a globular disulphide-linked dimeric protein (ca. 150 kDa), and linked to the membrane via a glycolipid anchor. The active site of AChE contains two subsites, first the esteratic catalytic site with a characteristic catalytic triad of amino acid residues (serine, glutamic acid, histidine), and second the anionic site responsible for the choline-binding (Fournier *et al.*, 1992; Fournier and Mutero, 1994; Gunning and Moores, 2001).

It is well-known that an altered AChE is one of the major mechanisms of the organophosphate and carbamate resistance. At date, numerous insect species, including noctuid pests, have altered AChEs, which correspond to resistant insects. Strains containing AChE with reduced sensitivity are showing modified insecticide binding characteristics or catalytic properties towards substrates and inhibitors (Fournier and Mutero, 1994; McCaffery, 1999; Gunning and Moores, 2001). The first case of a modified AChE (and indeed the first case of target-site insensitivity at all) was described in a spider mite strain with decreased sensitivity to organophosphates (Smissaert, 1964).

A simple, colourimetric assay for the determination of AChE activity is the method according Ellman *et al.* (1961). The biochemical reaction using an artificial substrate acetylthiocholine iodide and dithionitrobenzoate produces a yellow colouration in the presence of a small amount of AChE (Figure 18). This technique can be used to detect an insensitive AChE by inhibition studies using enzyme preparations from resistant populations.

Figure 18: The artificial substrate acetylthiocholine iodide is hydrolysed by AChEs, resulting in liberated thiocholine iodide and formed by the reaction with dithionitrobenzoate a coloured product, 2-nitro-5-thiobenzoate

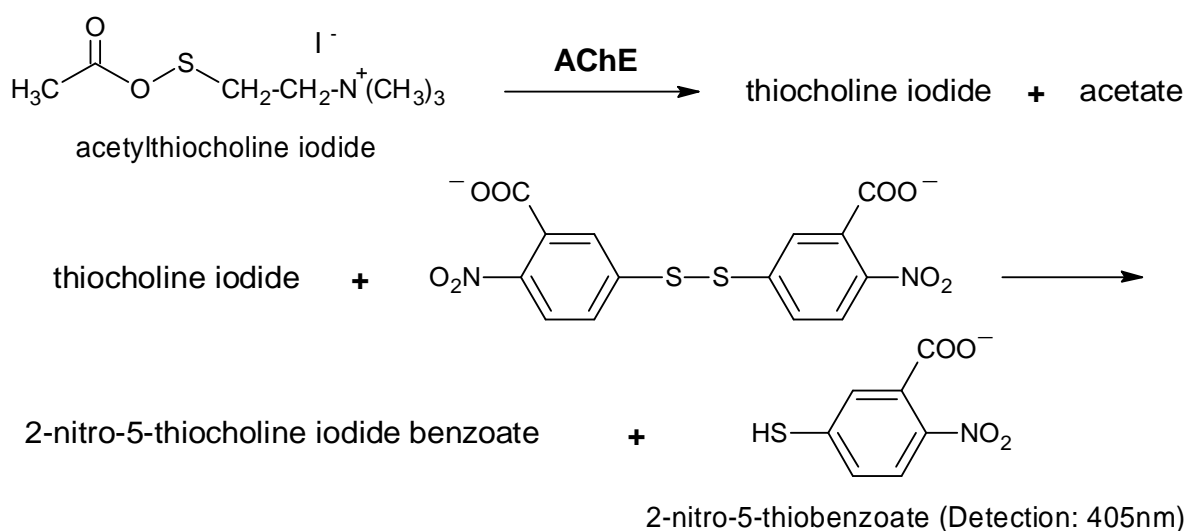

The basis of the modified AChE (MACE) is well-known in several pest species. Molecular studies have identified that point mutations associated with target-site insensitivity in genes encoding the AChE confer structural modifications.

The phenomenon of insensitive AChE was intensively investigated in *Drosophila melanogaster*. In this species, AChE is encoded by a unique locus (*ace*), and different point mutations were found and associated with reduced sensitivity in resistant strains, however similar findings were made in other species (Fournier and Mutero, 1994; Feyereisen, 1995). Additionally, the co-existence of two or more mutations caused even higher levels of insensitivity to organophosphates and carbamates (Fournier and Mutero, 1994). Recently, in some insect species, such as diamondback moth *Plutella xylostella* (Baek *et al.*, 2005), a second non-homologous *ace*-gene carrying mutations conferring AChE insensitivity were identified. An AChE over-expression seems to be a second option for insecticide resistance through increasing the amount of the enzyme, but poorly documented yet (Fournier and Mutero, 1994).

1.5.3.3 Nerve insensitivity: target-site resistance to pyrethroids

The primary protein structure, which displays the ion-pore of insect sodium channel, is similar to the mammalian sodium channel α -subunits, and the corresponding gene of the insect nervous system is termed *para*. Voltage-gated sodium channels (vgSCs) are transmembrane proteins; generating the action potentials in the neuronal membranes in most excitable cells that are responsible for conduction of electrical pulses throughout the nervous

system. This large glycoprotein (see Figure 19) contains four repeated homologous domains (I-IV), each having six membrane spanning segments (S1 to S6) connected by intracellular or extracellular loops of amino acid sequences (Vais *et al.*, 2001; Dong, 2003). When such channels are open, they generate a transient Na^+ current and lead to a depolarisation of the membrane potential responsible for conduction of electrical pulses throughout the insect nervous system. These channels are targets for many natural and synthetic toxins, including insecticides such as pyrethroids, DDT and oxadiazines (Narahashi, 2000; Vais *et al.*, 2001; Dong, 2003).

Intensive use of pyrethroids and DDT in insect control has resulted in the evolution of resistance in many insect species. One important mechanism that confers resistance to both insecticides is reduced target-site sensitivity in the insect nervous system, which is also known as knockdown resistance or *kdr* (Vais *et al.*, 2001; Zlotkin, 2001). This type of resistance has been reported in a range of species, but was first and in detail studied in the housefly (*Musca domestica*), including the highly resistant variant *super-kdr* (Farnham *et al.*, 1987).

Molecular studies have identified that *kdr* results from a mutation(s) in the voltage-gated sodium channel gene of insects. In recent years, several mutations (some examples are given in Figure 19) associated with *kdr* or *super-kdr* resistance not only in the housefly (Williamson *et al.*, 1993), but also in some important pest species were identified (Martinez-Torres *et al.*, 1997; Vais *et al.*, 2001; Dong, 2003).

Figure 19: A schematic diagram of a voltage-dependent (gated) sodium channel. The positions (•) of various mutations associated with *kdr* or *super-kdr* in agriculturally or medically important arthropod species are marked (Mutations taken from Dong, 2003).

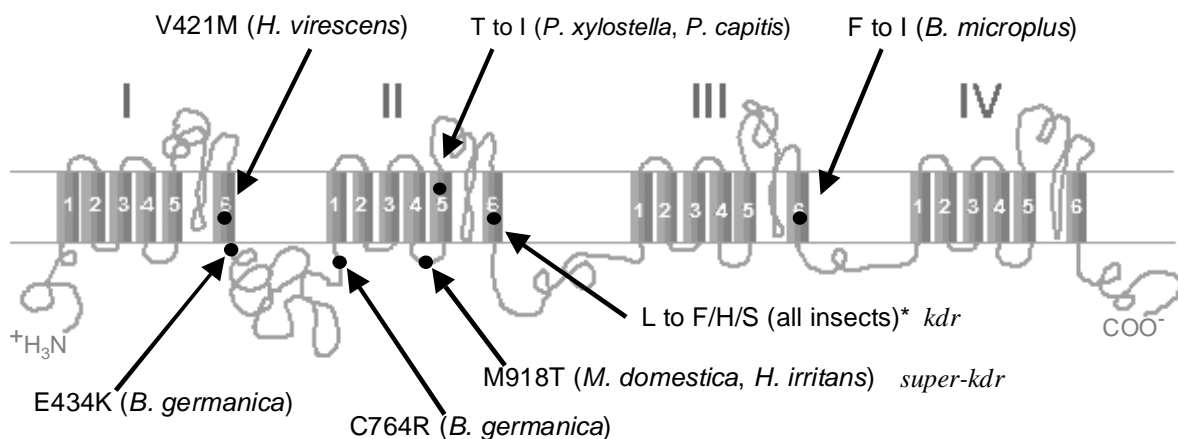

* L to F in *M. domestica* (L1014F), *B. germanica* (L993F), *H. irritans*, *P. xylostella*, *M. persicae*, *L. decemlineata*, *An. gambiae* and *C. pipiens*
 L to H in *H. virescens*
 L to S in *An. gambiae* and *C. pipiens*

1.6 Resistance management

1.6.1 Cross-resistance

Resistance mechanisms rarely affect just one compound, usually they at least confer also resistance to other members of the the same chemical class, a phenomenon called cross-resistance. Cross-resistance is different from multiple resistance, which occurs when insects develop resistance to compounds of several chemical classes by expressing non-specific or multiple resistance mechanisms.

Generally, insecticides within a chemical group are sharing a common mode of action. The frequent application of compounds coming from one group can dramatically increase the risk of cross-resistance, and thus selecting for target-site resistance. The “IRAC mode of action classification scheme” is based on the grouping of insecticides through there modes of action (see Table 3). This knowledge is converted to a practical guide to design an effective insecticide resistance management (IRM) strategy in order to minimise the use of compounds of one group of action and will always minimise selection pressure.

The metabolic resistance mechanisms are not linked to the specific mode of action of insecticides, however chemical structures usually need to show a certain degree of similarity when specifically binding to a target-site, and therefore one resistance mechanism confer cross-resistance in chemical classes.

Cross-resistance studies are important and result in cross-resistance pattern, which in turn are essential in order to fine-tune management recommendations, for example the alternation of insecticides to avoid continuous selection for the same resistance gene or mechanism.

Table 3: Overview about insecticides used in this study, including information about the chemical group and mode of action. The scheme is based on the mode of action classification developed by IRAC (Insecticide Resistance Action Committee).

Active Ingredient	Chemical Sub-group or exemplifying Active Ingredient	Primary Site of Action	Group
Flubendiamide	Diamides	Ryanodine receptor modulators	28
Deltamethrin Etofenprox	Pyrethroids	Sodium channel modulators	3A
Carbofuran Methomyl Thiodicarb	Carbamates	Acetylcholinesterase inhibitors	1A
Methamidophos Paraoxon-ethyl Triazophos	Organophosphates		1B
Endosulfan	Cyclodiene organochlorines	GABA-gated chloride channel antagonists	2A
Hexaflumuron Triflumuron	Benzoylureas	Inhibitors of chitin biosynthesis	15
Indoxacarb	Indoxacarb	Voltage-dependent sodium channel blockers	22A
Emamectin	Avermectins	Chloride channel activators	6
Spinosad	Spinosyns	Nicotinic acetylcholine receptor allosteric activators	5
Chlorfenapyr	Chlorfenapyr	Uncouplers of oxidative phosphorylation via disruption of the proton gradient	13
Methoxyfenozide	Diacylhydrazines	Ecdysone receptor agonists	18

IRAC Mode of Action Classification v6.1 (2008)

1.6.2 Integrated pest and insecticide resistance management

Many pest insects have developed resistance to a broad variety of chemical classes during the last five decades. Not only have resistant species increased greatly in number, but the intensity and extent of some resistance problems has increased alarmingly. Continued selection with insecticides has allowed the survival of resistant populations, which have generally proved difficult or sometimes even impossible to control.

Today farmers have more tools to manage resistance than ever: sophisticated crop protection products, transgenic crops and Integrated Pest Management (IPM) techniques.

The IPM philosophy is to limit economic damage to the crop and simultaneously minimize adverse effects on non-target organisms in cropping systems, the surrounding environment and on consumers of the end product for example by crop rotation, pest-resistant crop varieties and chemical attractants or deterrents.

One important component of IPM strategies is Insecticide Resistance Management (IRM), which involves three basic components: the monitoring of pest complexes for population density and trends, focusing on economic injury levels (economic threshold) and integrating control strategies (e.g. application time).

Finally, the key to success is collaboration. Only when all persons concerned - agrochemical industry, entomologists, advisers and growers - are working together it is possible to reduce the risk of spreading and establishing of resistance in pest populations.

2 OBJECTIVE

Crop protection is a research-based business and the development of new compounds is becoming more and more difficult. On one hand the number of (truly lethal!) insecticidal target-sites is rather limited, and on the other hand new products must conform to high standards, such as outstanding effectiveness, environmental safety, IPM compatibility and economical properties.

Particularly, the registration procedure, before the product is launched for full commercial use, is seen to be the point at which resistance risk assessment studies must be implemented. Resistance risk analysis is a two-stage process in which the possibility of the development of a resistance risk and its likely impact are evaluated. This should include strategies to avoid or delay the appearance of resistance in the future, e.g. use of a newly registered compounds.

One special part of the present thesis was to provide baseline data, an efficacy profile incl. pharmacokinetic investigations and cross-resistance patterns for the novel insecticide flubendiamide in several lepidopteran species. All data taken together should allow describing an initial resistance risk assessment even before market launch.

The second aim of the work was to investigate and describe the biochemical mechanisms leading to multiple resistance commonly observed in a *S. exigua* field strains coming from under-glass vegetable growing areas in southern Spain. For the detection of detoxification enzyme systems, such as monooxygenases, it was important to establish practicable biochemical methods sometimes adjusted to each target pest. The results are important for a long-lasting resistance management strategy for the new compound, and should also provide sustainable measures by including work on established chemistry.

The objectives of this study were:

- Investigate the biological efficacy profile of flubendiamide in two types of bioassay (artificial diet, spray application) against larvae of different important lepidopteran pest species such as boll- and armyworms.
- Extensive description of the possible cross-resistance pattern of flubendiamide in lepidopteran pest species known to be resistant to compounds coming from diverse chemical classes of insecticides. Such studies should gain information for future rotational strategies to manage insecticide resistance including flubendiamide.

-
- Assessment of the baseline susceptibility of larvae of flubendiamide against different pest lepidopteran strains (three different species). This is necessary for the determination of diagnostic doses for resistance monitoring purposes in the future.
 - Design of an appropriate, simple, robust and reliable bioassay method (test kit) for a worldwide susceptibility monitoring to be used under field conditions.
 - Initiation of a global resistance monitoring for flubendiamide in larvae of *S. exigua* and *H. armigera* based on the designed diagnostic dose bioassay test kit.
 - Investigate the insecticidal activity of deltamethrin, flubendiamide and triflumuron combined with synergists against beet armyworm larvae, in order to see if and to what extent metabolic enzymes are involved in resistance phenomena.
 - Comparative investigation of the penetration, translocation and excretion (pharmacokinetic studies) of three radiolabelled insecticides, i.e. [¹⁴C]deltamethrin, [¹⁴C]triflumuron and [¹⁴C]flubendiamide, in an insecticide susceptible and resistant strain of *S. exigua*.
 - Establishment of sensitive biochemical methods to determine the activity of four important enzymes (acetylcholinesterases, glutathione S-transferases, carboxylesterases and monooxygenases) commonly associated with resistance to established insecticides in second-instar larvae of *S. exigua*.
 - Identification and description of possible biochemical mechanisms of resistance in a multi-resistant *S. exigua* strain from Spain.
 - Investigation of mechanisms of resistance to pyrethroids in *S. exigua* using molecular biology methods, through pyrosequencing-based detection of single-nucleotide polymorphisms known to confer *kdr* resistance.

3 MATERIAL AND METHODS

3.1 Chemicals and insecticides

3.1.1 Chemicals and reagents

All chemicals were obtained from Sigma (Steinheim, Germany), except of 1-chloro-2,4-dinitrobenzene (Acros, Geel, Belgium), 1-naphthyl acetate (Serva, Heidelberg, Germany), and dithionitrobenzoate (Boehringer, Mannheim, Germany). All other reagents were of analytical grade.

3.1.2 Insecticides and synergists

Chlorfenapyr, deltamethrin, flubendiamide, indoxacarb, methoxyfenozide, spinosad, S,S,S-tributyl-phosphorotrithioate (DEF), and triflumuron were obtained in-house. The insecticides endosulfan, etofenprox, hexaflumuron, methamidophos, and triazophos were purchased from Ehrenstorfer (Augsburg, Germany), whereas carbofuran, methomyl, paraoxon-ethyl, profenofos, and thiodicarb were supplied by Riedel de Haen (Seelze, Germany). Piperonyl butoxide (PBO) was purchased from Acros (Geel, Belgium).

The insecticide emamectin was a formulated commercial product (Affirm[®], EC 1%) and suspended in water only.

3.2 Lepidopteran strains

The experiments were carried out on two strains of the beet armyworm, *S. exigua* (Table 4). The UK susceptible strain (SPOD-EX S) was obtained in 1989 and strain SPOD-EX E-98 was originally collected from pepper in Almeria, Spain (1998). The cotton bollworm strain HELI-AR and the tobacco budworm strain HELI-VI are insecticide-susceptible and maintained for many years under laboratory conditions (Table 4).

All strains were maintained in the laboratory without insecticide selection under controlled conditions in the dark at 27°C and 60% r.h., on a beanmeal-based artificial diet.

Table 4: Strains of *Spodoptera exigua*, *Helicoverpa armigera* and *Heliothis virescens* tested

Species	Strain / Abbreviation	Origin	Host	Received
<i>Spodoptera exigua</i>	SPOD-EX S	United Kingdom	-	1989
	SPOD-EX E-98	Spain	Pepper	1998
<i>Helicoverpa armigera</i>	HELI-AR	“Agrevo”	-	2000
<i>Heliothis virescens</i>	HELI-VI	“Hoechst”	-	1993

Several studies were done with different larval instars of the four strains. Early instars right after ecdysis were used for bioassays, biochemical tests and molecular biological investigations. Fifth-instar larvae (16-24h after ecdysis) were used for pharmacokinetic and application (preferred mode of entry) studies (Table 5).

Table 5: Weight of the different larval instars of the four lepidopteran strains

	Weight per larva \pm SD [mg]					
	1 st	2 nd	3 rd	4 th	5 th	5 th
Strain	Early instar after ecdysis					16-24h
SPOD-EX S	0.097 \pm 0.005	0.431 \pm 0.049	1.96 \pm 0.07	25.4 \pm 4.4	49.5 \pm 6.4	145.5 \pm 18.4
SPOD-EX E-98	0.074 \pm 0.004	0.374 \pm 0.072	1.49 \pm 0.13	22.2 \pm 4.4	46.9 \pm 6.0	128.2 \pm 12.3
HELI-AR	0.112 \pm 0.011	0.572 \pm 0.005	2.06 \pm 0.23	50.5 \pm 8.1	129.7 \pm 16.3	- -
HELI-VI	0.123 \pm 0.005	0.579 \pm 0.038	2.12 \pm 0.34	56.9 \pm 15.6	124.6 \pm 14.8	- -

3.3 Bioassays

3.3.1 Larval spray bioassay

The spray bioassay on larvae was carried out in a 12-well tissue culture plate system. Leaf discs (2cm in diameter) were placed on a bed of agar (15g litre⁻¹; 1ml), with the upper leaf-side upwards.

Leaf discs were cut out from maize plants (*Zea mays*, var. “Prominent”) or cotton (*Gossypium hirsutum*, var. “Tapladilla”) cultivated for three weeks in the greenhouse at $23 \pm 1^\circ\text{C}$, 75% r.h. and ambient photoperiod. The maize plants were used for *S. exigua*, and cotton for *H. armigera* and *H. virescens*.

Insecticide stock solutions were prepared by dissolving 3 mg active ingredient in 480 μl acetone (incl. 2.56% of a 3:1 (v/v) mixture of N,N-dimethylformamide (DMF) and alcyarylpolyglycoether (emulsifier W)), and diluted with water to 1g a.i. litre⁻¹. Further dilutions steps (1:5) were prepared with 0.1% (w/v) emulsifier W. A starting solution without active ingredient served as internal control.

The insecticide solutions were applied using a dilutor-based spray applicator (Zinsser Analytic, Frankfurt, Germany). The automatic (one robotic arm with a 4-channel system) system sprayed 2.5 μl solution per cm², corresponding to 250 l per hectare.

Subsequently, a single 2nd instar larvae was transferred into each well of an air-dried plate (at least $n=12$ in triplicate). The plates were covered with tissue paper, sealed with a ventilated lid and stored at RT in the dark. After 4 days, larvae were scored for efficacy/mortality.

3.3.2 Larval artificial diet bioassay

Cylinders of artificial diet (height: 0.6cm; diameter: 1.5cm) were placed in 24-well tissue culture plates. The stock solution of 1g litre⁻¹ was prepared by dissolving 8 mg active ingredient in 80 μl of a 3:1 (v/v) mixture of DMF and emulsifier W and diluted 100-fold with water. Further 1:5 dilution steps were prepared with water, and solvent treated cylinders served to assess control efficacy. Twelve diet-cylinders were applied each with 100 μl solution per concentration, and represented one replicate. The experiment was repeated at least three times. One 2nd instar larva was transferred onto each treated cylinder. The plates were covered by tissue paper, sealed with a ventilated lid and stored at RT in the dark. Percentage efficacy was assessed after seven days. The compound flubendiamide was additionally tested on all five instars (freshly ecdysed).

3.3.3 Worldwide monitoring

This monitoring-kit was developed to investigate possible variations in the effect of flubendiamide against field-collected populations and laboratory strains of *S. exigua* and *H. armigera*.

The test system is based on the artificial diet bioassay as described above (section 3.3.2). A single diagnostic concentration was used, providing 99% efficacy (EC₉₉) with the laboratory strains. One “kit” consists of two 24-well plates, i.e. one with untreated artificial diet (control) and one plate with artificial diet treated with a diagnostic concentration of flubendiamide (1 mg litre⁻¹).

Each plate was covered with self-adhesive film during shipping, just for conservation and protection during the transport. A tissue paper and a ventilated lid were provided with each plate to properly carry out the bioassay (Figure 20).

The collectors were instructed to sample and transfer one larva to each well of the provided plates ($n=24$ per plate) and subsequently to store the plate at RT (ca. 20-25°C) in the dark. After six to seven days the number of larvae affected was scored. The field-collected larvae used should be between 2nd and beginning of the 3rd instar (length: 3-9mm). Fourteen field populations were collected from June to October 2004, from Spain, Turkey, Thailand and Mexico and tested. Additionally, four laboratory strains were tested from Australia. Additional information are summarized in Appendix A.

Figure 20: Monitoring – Instruction scheme for collectors how to use the monitoring-kit

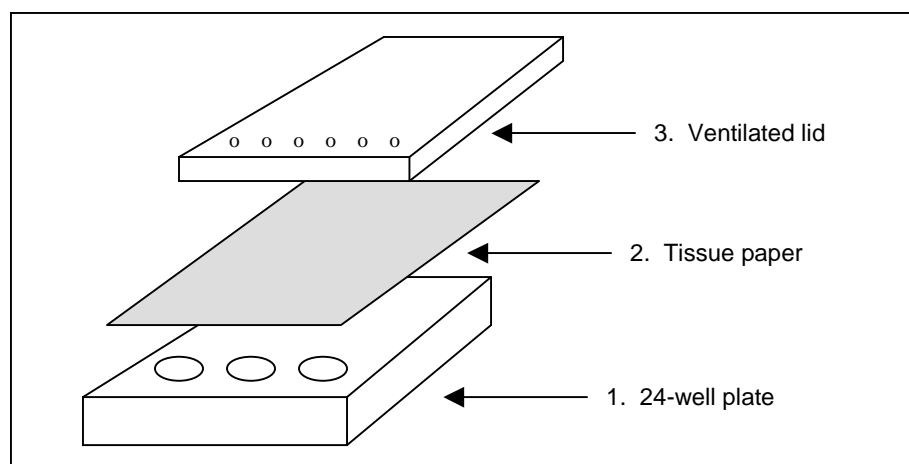

3.3.4 Application and synergism studies

In this experiment, 5th instar larvae, 16-24h old, were used (Table 5). Insecticides and synergists were dissolved in acetone, and 0.5µl solution was applied on the dorsal thorax with a Hamilton microsyringe and applicator (Reno, NV, USA). The insecticides deltamethrin, flubendiamide and triflumuron were diluted with acetone, the resulting concentrations ranging from 0 to 100% efficacy. For each concentration, 15 larvae were treated, and each experiment was at least replicated three times.

For synergism studies, the larvae were treated with PBO (30µg/0.5µl), DEF (15µg/0.5µl) and profenofos (1µg/0.5µl) 2h prior to insecticide application (see above Table 6). Controls were treated with acetone or synergist alone.

After application of the insecticide or acetone (control), the larvae were held individually in 24-well plates with artificial diet. Finally, the efficacy was assessed 7d after insecticide application.

Table 6: Synergists

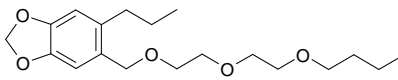
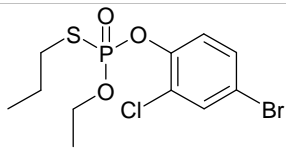
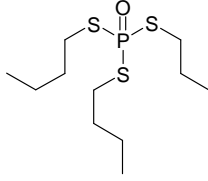
Synergist	Inhibitor of	Conc.	Structure
Piperonyl butoxide (PBO)	Mono-oxygenases <i>(esterases in some species)</i>	30 µg	
Profenofos	Carboxyl-esterases	1 µg	
S,S,S-tributyl-phosphorotrithioate (DEF)	Esterases	15 µg	

3.3.5 Pharmacokinetic studies

Insect treatment: Fifth-instar larvae (16-24h old) of strains SPOD-EX S and SPOD-EX E-98 were used for pharmacokinetic studies. Experiments with flubendiamide were only carried out on strain SPOD-EX S. The radiolabelled compounds (Table 7; see also data sheets in Appendix B) were dissolved in acetone to final concentrations. The larvae were treated with 2.5ng [¹⁴C]deltamethrin, 25ng [¹⁴C]flubendiamide and 27ng [¹⁴C]triflumuron per larva (sublethal dose). Aliquots (0.5µl per larva) in acetone were applied dorsally with a microsyringe and applicator (see 3.3.4). For each time point six larvae were treated (placed in one glass petri dish), and the experiments were replicated three times. After application the larvae were provided with a small quantity of artificial diet, and the radioactivity was recorded 2, 4, 8, 24 and 48 hours after treatment.

Table 7: Radiolabelled compounds (+ Appendix B)

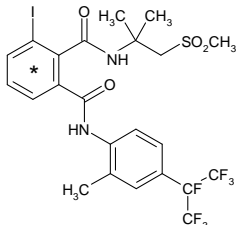
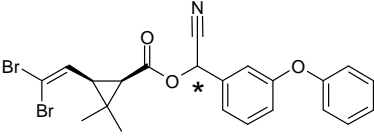
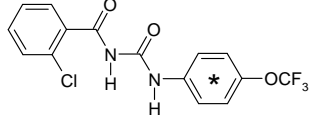
Compound	Radio-chemical purity	Total Activity [KBq]	Spec. Activity [MBq]	Structure
[phthalic acid ring-UL- ¹⁴ C] Flubendiamide	97.7 %	370	4.3	
[benzyl- ¹⁴ C] Deltamethrin	97.6 %	370	4.24	
[phenoxy-UL- ¹⁴ C] Triflumuron	97.7 %	370	4.2	

* position of label

Estimation of non-penetrated radioactivity: The amount of radiolabelled [¹⁴C]-equivalents which were not absorbed by the larvae cuticle were assayed at different elapsed time intervals with the following procedure and quantified by liquid scintillation counting (LSC):

Petri dishes were rinsed and washed with acetone (4 x 2ml), and the washes were transferred into scintillation vials. Each group of larvae ($n=6$) was washed in a scintillation vial, containing 2ml acetone (“surface wash”) and then removed after 30 sec. This procedure was repeated three times. The acetone samples (“petri dishes” and “surface wash”) were evaporated to dryness and the residues were redissolved in 2.5ml liquid scintillation cocktail (Ultima Gold, Perkin Elmer, Rodgau-Jügesheim, Germany) and measured by LSC (Beckman LS 6500, Krefeld, Germany).

Estimation of internal and excreted radioactivity by combustion: The faeces of each time point was collected in special paper cups (Schleicher&Schuell, Dassel, Germany). The faeces and acetone-washed larvae (“internal”) were gently dried (60°C, 24h), and pressed to a pellet form. The pellets were then combusted separately in a biological oxidiser (OX-500, Harvey Instrument Corp., Hillsdale, NJ, USA). The liberated ¹⁴CO₂ was trapped in scintillation cocktail (Oxysolve C-400, Zinsser) and quantified.

3.4 Biochemistry

3.4.1 Protein determination

The amount of protein in biological samples was determined with slight modifications according to Bradford (1976). Briefly, 500 μ l sample were added to 500 μ l of the Bradford reagent (80 mg Coomassie Brilliant Blue G-250) dissolved in 1 litre 3% perchloric acid, $E_{465\text{nm}} = 1.3-1.5$). If less than 500 μ l sample was used the volume was adjusted to 500 μ l with the appropriate buffer (depending on homogenate preparation). After 5 min incubation the absorbance at 595nm was measured in a photometer (Ultrospec 2000, Pharmacia Biotech, Uppsala, Sweden). Protein concentrations were determined using a bovine serum albumine (BSA) standard curve with concentrations between 1.5 μ g and 15 μ g.

3.4.2 Glutathione S-transferases

3.4.2.1 Standard photometric assay using 1-chloro-2,4-dinitrobenzene as substrate

Mass homogenate: The GST activity was measured using 1-chloro-2,4-dinitrobenzene (CDNB) and reduced glutathione (GSH) as substrates according to Nauen and Stumpf (2002) in 96-well microplates. Twenty 2nd instar larvae were homogenized manually in 1ml 0.05M Tris-HCL buffer (pH 7.5) and centrifuged for 5 min at 4°C and 10,000g. The supernatant was diluted 10-fold in assay buffer. The total reaction volume per well of a 96-well microplate was 300 μ l, consisting of each 100 μ l supernatant (0.2 larva equivalents), CDNB (containing 1% (v/v) ethanol) and GSH in buffer, giving final concentrations of 0.4mM and 4mM of CDNB and GSH, respectively. The non-enzymatic reaction of CDNB with GSH measured without supernatant served as control. The change in absorbance was measured continuously for 5 min at 340nm and 25°C in a Thermomax kinetic microplate reader (Molecular Devices, Sunnyvale, CA, USA). Changes in absorbance per minute were converted into pmol CDNB conjugated/min/larva equivalent using the extinction coefficient of the resulting 2,4-dinitrophenyl-glutathione: $\epsilon_{340\text{nm}} = 9.6 \text{ mM}^{-1} \text{ cm}^{-1}$ (Habig *et al.*, 1974).

Frequency distribution: Each larva (2nd instar) was homogenised in 320 μ l assay buffer and centrifuged. The supernatant was diluted 1:1, resulting in 0.16 larva equivalents per well. The subsequent activity measurement was performed as described above. Totally, fifty individual larvae were measured for each strain.

3.4.2.2 Fluorometric assay using monochlorobimane as substrate

Mass homogenate: GST activity towards monochlorobimane (MCB) was determined in 96-well microplates as reported previously (Nauen and Stumpf, 2002). Figure 21 shows the reaction of MCB with the reduced glutathione (GSH) that forms a stable fluorescent glutathione adducts by GST.

Twenty 2nd instar larvae were homogenized in 1ml HEPES buffer (0.05M, pH 6.8) and centrifuged for 5 min at 4°C and 10,000g. The total reaction volume was 300µl per well, and consisted of 50µl supernatant (equivalent of 1 larva), 50µl buffer, 100µl MCB (containing 1% (v/v) ethanol; final conc. 0.2mM) and reduced glutathione dissolved in 100µl buffer (final conc. 2mM). Wells with buffer instead of supernatant served as control. After 20 min of incubation (25°C, 400rpm on a shaker) the fluorescence was determined in an endpoint assay using a spectrofluorometer (Tecan, Crailsheim, Germany) at an emission wavelength of 465nm, while exciting at 390nm (gain 50).

Figure 21: Reaction of monochlorobimane and GSH catalysed by glutathione S-transferases

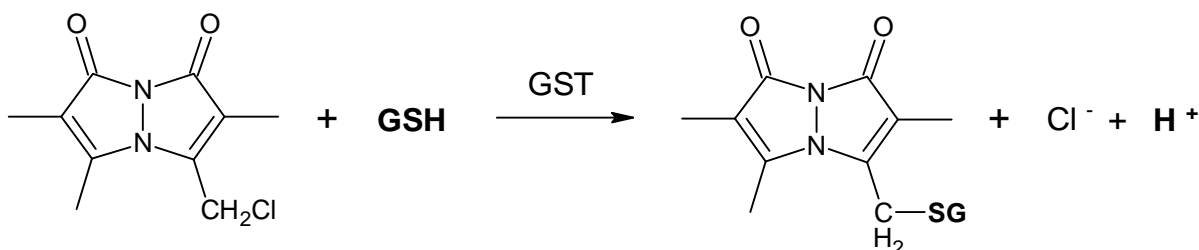

3.4.3 Carboxylesterases

3.4.3.1 Photometric assay with 1-naphthyl acetate

Mass homogenate: Activity of carboxylesterase (CE) was measured with minor modifications according to Grant *et al.* (1989). Twenty 2nd instar larvae were homogenised in 1 ml sodium-phosphate buffer (0.1M, pH 7.6) containing 0.1% Triton X-100. The homogenates were centrifuged at 10,000g and 4°C for 5 min. The resulting supernatant was diluted 20-fold and used as enzyme source. The substrate stock solution contained 100mM 1-naphthyl acetate (1-NA) dissolved in acetone. Nine mg of Fast blue RR salt was dissolved in 15ml of sodium-phosphate buffer (0.2M, pH 6.0), the solution was filtered and to a 10ml portion was added 100µl 1-NA stock solution.

For the determination of CE activity 25µl enzyme source (0.025 larva equivalents) and 25µl sodium-phosphate buffer (0.2M, pH 6.0) were added to each well of a 96-well microplate. The reaction was started by adding 200µl of the substrate solution. Reaction without enzyme source served as control. The CE activity was monitored over 10 min at 23°C using a Thermomax microplate reader at 450nm.

Inhibition study with DEF: S,S,S-Tributyl-phosphorotrithioate (DEF) was used for the inhibition of CE *in vitro*. The homogenate of 2nd instar larvae was prepared as described above. DEF was tested at a final concentration of 100µM in three replicates. Twentyfive µl enzyme source (0.025 larva equivalents) and 25µl inhibitor solution (containing 1% acetone) were pre-incubated for 10 min (25°C, 400rpm on a shaker) and then the CE activity was measured as described above. The positive control (full reaction rate) contained enzyme source and 1% acetone in buffer.

Standard curve: The standard curve was designed by using different concentrations of 1-naphthol (0.25 to 2.5nmol) in 250µl fast blue RR salt-solution (1% acetone).

Frequency distribution: A single larva (2nd instar) was homogenised in 200µl sodium-phosphate buffer and centrifuged. The supernatant was diluted 5-fold and used as enzyme source using the method described above ($n=50$).

3.4.3.2 nPAGE and inhibition studies

Native polyacrylamide gel electrophoresis (nPAGE) analysis was performed in a NuPAGE[®] electrophoresis system (Invitrogen, Carlsbad, CA, USA), using 8-16% Tris-Glycine Pre-cast gels (1mm x 10 well) according to the manufacturer's instructions. Gels were run at 125V for 4h on ice. The electrophoresis was carried out with Tris-Glycine native buffer (Invitrogen) as running buffer.

Mass homogenates were prepared as described above and 25µl were applied onto the gel, resulting in 1.5 larva equivalents per well. The gels were stained with slight modifications according to Byrne and Devonshire (1993). The staining solution consists of 0.2% Fast blue RR-solution (30ml) containing 600µl 1-naphthyl acetate (30mM in acetone). The gels were stained for at least 20 min in the darkness, fixed in 7% acetic acid and subsequently scanned for documentation.

Inhibition studies: Gels were pre-incubated for 10 min in 30ml 0.2M sodium-phosphate buffer (pH 6.0) including 300µl of acetonic inhibitor solution and also added to the solution during the staining process. The inhibitors were tested at final concentrations ranging from 0.03mM to 1mM (Table 8).

Table 8: Chemicals and final concentrations for inhibition of carboxylesterases in nPAGE gels

Inhibitor		Final Concentration [mM]
Compound	Deltamethrin	0.3
	Etofenprox	0.03
	Triazophos	0.3
	Thiodicarb	0.1
	Carbofuran	0.3
	BW284c51	0.03
	Eserine	0.3
	Synergist	PBO
DEF		1.0
Profenofos		0.1

3.4.4 Cytochrome P₄₅₀-dependent monooxygenases

3.4.4.1 Fluorometric assay to measure 7-ethoxycoumarin O-deethylation

The cytochrome P₄₅₀-dependent monooxygenase (monooxygenase) activity was measured with slight modifications according to Stumpf and Nauen (2001). The O-deethylation of 7-ethoxycoumarin (7-EC) was determined fluorometrically in microtiter plate format.

Fifth-instar larvae: Microsomes were prepared from guts of freshly moulted 5th instar larvae.

The larvae were split longitudinally and the guts were dissected. The gut contents were removed by gently squeezed out. The collected gut tissues were transferred into a Potter homogenizer. Ten guts were pooled and homogenized for 2 x 6s (on ice) in 5ml sodium-phosphate buffer (0.1M, pH 7.6, 1mM EDTA, 1mM DTT, 200mM sucrose) at 1,500rpm. The homogenate was centrifuged for 5 min at 5,000g (4°C). The pellet was discarded and the resulting supernatant was centrifuged again at 4°C for 15 min at 15,000g followed by a last ultra-centrifugation step at 100,000g for 60 min.

The microsomal pellet was resuspended in 300µl sodium-phosphate buffer (0.1M, pH 7.6) and served as enzyme source. Fifty µl enzyme source, 1µl 7-EC (final conc. 0.4mM) in acetone and 39µl assay buffer were added into each well of a 96-well microplate. The reaction was started by adding 10µl of aqueous NADPH (final conc. 1mM) and incubated for 30 min (30°C, 400rpm on a shaker). Reaction without enzyme source served as control. The

self-fluorescent NADPH was removed by adding 10 μ l oxidized glutathione (30mM in water) and 10 μ l glutathione reductase (0.5 units).

After another 10 min of incubation (RT) the reaction was stopped by adding 120 μ l of 50% acetonitrile in TRIZMA-base buffer (0.05M, pH 10). The fluorescence was determined in an endpoint assay using a spectrofluorometer (Tecan) at an emission wavelength of 465nm, while exciting at 390nm (gain 70).

Second-instar larvae (decapitated): In a second approach, monooxygenase activity was measured using decapitated 2nd instar larvae as enzyme source. Mass homogenates of 60 decapitated larvae were prepared manually in 600 μ l ice-cold sodium-phosphate buffer (0.1M, pH 7.6) with a plastic pestle. The homogenates were centrifuged at 10,000g and 4°C for 5 min. Fifty μ l supernatant (5 larva equivalents) was used as the enzyme source and measured as described above for microsomes.

Inhibition study with PBO: The inhibition study with piperonyl butoxide (PBO) was carried out in homogenated obtained from decapitated 2nd instar larvae. PBO was tested at a final concentration of 1mM in three replicates. One μ l PBO solution was added to 50 μ l enzyme source (5 larva equivalents) prior to 7-EC and NADPH addition, and the monooxygenase activity was measured as described above. The positive control contained enzyme source and 1 μ l acetone.

Standard curve: The standard curve was prepared using 7-hydroxycoumarin (umbelliferone) in seven concentrations (1.6 to 100 pmol).

3.4.5 Acetylcholinesterases

3.4.5.1 Photometric determination of acetylcholinesterase activity

Mass homogenate: Acetylcholinesterase (AChE) activity was assayed using the procedure described by Ellman *et al.* (1961). Mass homogenates of 30 larvae (2nd instar) were prepared in 1ml 0.1M sodium-phosphate buffer pH 7.5, containing 0.1% (w/v) Triton X-100. After 20 min solubilisation on ice, the homogenates were centrifuged at 10,000g and 4°C for 5 min and the resulting supernatant was used as the enzyme source. Fifty μ l supernatant (1.5 larva equivalents) were added to 50 μ l assay buffer without Triton X-100 into the wells of a microtiter plate. Substrate solutions of acetylthiocholine iodide (ATChI) and dithionitrobenzoate (DTNB) were prepared in sodium-phosphate buffer (without Triton X-100), giving final concentrations of 0.5mM each. The reaction was started by adding 100 μ l each of ATChI and DTNB buffer solutions. Wells with buffer instead of ATChI served as

control. The change in absorbance was measured continuously for 20 min at 405nm and 25°C using a Thermomax microplate reader.

Frequency distribution: A single larva (3rd instar) was homogenised in 100µl sodium-phosphate buffer and centrifuged as described above. Fifty µl supernatant (0.5 larva equivalent) was used as enzyme source using the method described above. The Frequency distribution was determined by using 50 individual larvae of each strain.

3.4.5.2 Inhibition studies and determination of kinetic parameters

Inhibition study – different inhibitors: Stock solutions of BW284c51, carbofuran, eserine, methamidophos, methomyl, paraoxon-ethyl and thiodicarb were prepared in acetone and diluted with buffer resulting in a concentration of 10% acetone. The inhibitors were tested at concentrations ranging from 0.003µM to 3000µM (final conc.) in three replicates. Fifty µl enzyme source (1.5 larva equivalents) and 50µl inhibitor (containing 10% acetone) were pre-incubated for 10 min (25°C, 400rpm on a shaker) and the AChE activity was measured as described above. The positive control (full reaction rate) contained 50µl enzyme source and 50µl buffer containing 10% acetone. The IC₅₀-values were calculated by non-linear regression using GraphPad Prism 4.0 software (GraphPad, San Diego, CA, USA).

Determination of kinetic parameters: K_m and V_{max} -values of AChE were determined using 1.5 larva equivalents per well and different ATChI concentrations (10µM - 3000µM final conc.). AChE activity was measured as described above and K_m and V_{max} -values were calculated using GraphPad Prism 4.0 software using the Michaelis-Menten equation.

3.4.6 Affinity purification of acetylcholinesterases

The AChE from *S. exigua* strains SPOD-EX S (660 mg) and SPOD-EX E-98 (330 mg) was purified using procainamide affinity chromatography. Second-instar larvae were collected and homogenized for 3 x 8 s (on ice) in 2.5ml 20mM sodium-phosphate buffer (pH 7.2), containing 0.5% Triton X-100 using a Potter homogenizer. After 20 min solubilisation on ice, the homogenate was centrifuged for 10 min at 10,000g (4°C). The pellet was discarded and the supernatant was centrifuged again at 4°C for 5 min at 10,000g.

After centrifugation the resulting supernatant (2.35ml each) was filtered and desalted on Sephadex G-25M PD10-columns (Amershan Bioscience, Freiburg, Germany), equilibrated with the same buffer without Triton X-100. Afterwards, proteins were eluted using manufacturer's guidelines. Fractions showing AChE activity were combined and loaded on a procainamide affinity gel column. Subsequently the column was washed with 20ml

sodium-phosphate buffer (20mM, pH 7.2). Several 0.5ml fractions were then collected by elution with sodium-phosphate buffer, pH 7.2 containing 1M NaCl. The fractions with acetylcholinesterase activity were combined and desalted on a PD10-column using a 20mM sodium-phosphate buffer (pH 7.2). Those fractions (500µl) containing AChE activity were pooled for further analysis. During purification, acetylcholinesterase activity was measured in each step as described above.

Inhibition studies and kinetic determinations with purified AChE: Carbofuran, methamidophos and thiodicarb were used for inhibition studies with purified AChE; the method was the same as described above.

Values of K_m and V_{max} of purified AChE from two *S. exigua* strains were exactly determined as described above for non-purified mass homogenate.

In both experiments, the enzyme source consisted of combined fractions of the last purification step (second PD10-column). The colourmetric AChE assay was carried out with 50µl and 20µl per well for strain SPOD-EX S and strain SPOD-EX E-98, respectively.

SDS-PAGE with purified AChE: SDS-PAGE was performed in a NuPAGE[®] electrophoresis system (Invitrogen) using the 4-12% Bis-Tris ready-made NuPAGE-Gel (Invitrogen) according to supplier recommended protocol. SeeBlue[®] Pre-Stained-Standard from (Invitrogen) was used as molecular weight standard. Gels were run at 200V for 20 min, and NuPAGE MES SDS running buffer was used. Aliquots of purified AChE from strains SPOD-EX S and SPOD-EX E-98 were 10-fold concentrated, using Centrifugal Filter Tubes 30kD (Eppendorf, Hamburg, Germany). As non-purified samples, mass homogenates (1.5 larva equivalents per well) were prepared as described above and 25µl of the prepared samples were applied onto the gel, finally containing 16.25µl enzyme source, 6.25µl LDS sample buffer, and 2.5µl reducing agent per well.

Protein bands were visualized by staining with 0.1% (w/v) Coomassie Brilliant Blue R-250 solution. The dye was diluted in a mixture of methanol, glacial acetic acid, water (45:10:45). The gels were incubated for 1h and subsequently destained (1h) with water containing 10% acetic acid and 20% methanol.

3.5 Molecular biology

3.5.1 RNA extraction from *Spodoptera exigua* for sodium channel amplification

Total RNA was extracted from insect material (10 larvae from each strain or a single larva, 3rd instar) was frozen in liquid nitrogen, and homogenized using a Mixer Mill (Retsch, Haan,

Germany) (1 min, frequency: 25 sec⁻¹). The powdered samples were filled up with 1ml mixture (1:1) of hot phenol and buffer (80°C). The buffer contained 1M Tris (pH 9), 0.5M EDTA, 8M LiCl and 20% SDS. After shaking some time a homogeneous mixture was obtained and 500µl chloroform was added, followed by a vigorous shaking over 30 min. The samples were centrifuged at 13,000g and 4°C for 10 min.

A phenol/buffer mixture (see above) was cooled down and 500µl of the “lower” phase and 500µl chloroform were added to the resulting supernatants. After shaking for 10 min (RT) it was centrifuged as described above and 600µl of the resulting supernatant was then added to 600µl chloroform and vigorously mixed for 5 min. The samples were centrifuged again at 12,000g and 4°C for 10 min. After this centrifugation step, 600µl of supernatant was mixed with 200µl 8M LiCl. For RNA precipitation the samples were stored at 4°C over night.

A subsequent centrifugation at 12,000g (25 min, 4°C) resulted in purified RNA pellets and the supernatant was discarded. The pellets were washed with 500µl 2M LiCl (ice-cold) and twice with 400µl 70% ethanol, dried on air and subsequently resuspended in 35µl sterile water.

In a second procedure the resulting sample was prepared using the RNeasy Mini Total RNA Isolation Kit (Qiagen, Hilden, Germany) including a DNase digestion step (RNase-Free DNase set, Qiagen). Both kits were used according to the manufacturer’s instructions.

RNA concentrations were determined photometrically in a biophotometer (Eppendorf), using 1µl sample in 100µl water.

3.5.2 Synthesis of first-strand cDNA of *Spodoptera exigua* strains

The total RNA (5µg) was reversely transcribed into single stranded cDNA with the SuperScript III Reverse Transcriptase (Invitrogen) and an oligo (dT) primer (500ng) for poly-A tailing. The reaction volume (20µl) contained also dNTP Mix (500µM each), first-strand buffer, 50mM DTT and RNase OUT for first-strand cDNA synthesis. The first-strand PCR was carried out with an annealing-step at 25°C for 5 min, extension of the first-strand at 50°C for 1h, and followed by inactivation of the reverse transcriptase (70°C for 15 min). Finally, the RNA was removed using RNase H (Invitrogen).

3.5.3 Polymerase chain reaction (PCR)

Several primers were designed from sequences of different insects, covering large parts of the sodium channel of *S. exigua*. The sources and abbreviations of these primers are given in Table 9. Several primer combinations were used including different annealing temperatures. The cDNA fragments served as templates for subsequent hot start PCR amplification using a

HotStarTaq Master Mix from Qiagen. The primer PCR reaction (30µl) contained 2mM MgCl (final conc.), 2µl cDNA and 0.6µl each primer. The DNA polymerase was activated by incubation at 95°C for 15 min. Thirty-five cycles of amplification were carried out by application of the following sequence: 1 min at 95°C (denature), 1 min at 45-56°C (anneal) and 2 min at 72°C (extend). A final extension step for 10 min at 72°C finished the PCR reaction.

Table 9: List of the primers used for PCR amplification

No.	Length (bp)	Name	Description	Sequence 5' - 3'
261	21	Helio <i>para</i> r	from Head et al. (1998) Amplifies linker III-IV in Heliothines	GTAGTCGAGGACAGTRCTKAA
260	21	Helio <i>para</i> f	from Head et al. (1998) Amplifies linker III-IV in Heliothines	ACGACGCTATTGATTCNAGRG
208	20	Sodium Channel IIS3 f	from Wang et al. (2003) Primer 4	GARGGNTGGAAYATHHTTYGA
207	19	Sodium Channel IIS6 r	from Wang et al. (2003)	TTAARTTRTCHATHATNAC
199	20	Insecta Sodium Channel f	from Ingles et al. (1996) Degenerate primer region 2509 - 2528	AGTGGHAACTATTTYTTCAC
172	21	Insect Sodium Channel r 4271	Degenerate Oligo for sodium channel amplification	KSCCCAKCCTTGCCAGAANGG

Degenerate Sequence: R = G/A; K = G/T; N = A/G/C/T; Y = T/C; H = A/C/T; S = G/C
r = reverse; f = forward

In order to obtain one single PCR fragment of the searching region (~2.4kb) the primers of the first PCR reaction, 199f and 261r, were used for a further PCR (see Table 9). A hot start PCR was used with slight modifications as described above. For the second reaction 3µl cDNA as template was used. Thermal conditions were: thirty-five cycles of 95°C for 1.15 min, 45 or 50°C for 1.15 min, and final extension at 72°C for 2.30 min.

All PCR products were separated by preparative electrophoresis on agarose gels (15g litre⁻¹) and visualization by ethidium bromide staining (1:20,000).

3.5.4 Cloning and sequencing of sodium channel from *Spodoptera exigua*

PCR fragments of expected size from both strains (SPOD-EX S and E-98) were extracted from the gel using QIAquick gel extraction kit (Qiagen). The resulting DNA was cloned into pCR II-TOPO plasmid vector included in a TOPO TA Cloning kit (Invitrogen), and transferred into chemical competent Top10 cells (Invitrogen). Both kits were used according to supplier recommended protocols. After culture and purification of the plasmids by mini-prep the insert-positive clones were identified by restriction enzyme digestion (*EcoRI*). Then, two positive clones of each strain were sequenced in both directions. The plasmids were sequenced using vector M13 forward and reverse primers by automated DNA sequencer ABI model 3700 (Applied Biosystems, Foster City, CA, USA) in the laboratory of Robert Kratzer, Bayer AG. Resulting sequences were aligned and analyzed using Vector NTI software program (Invitrogen).

3.5.5 Pyrosequencing

3.5.5.1 The principle of pyrosequencing

Pyrosequencing is a new high-throughput DNA sequencing method for analysis of single-nucleotide polymorphisms (SNPs) in gene sequences, for example to diagnose target-site resistance in single insects (Benting *et al.*, 2004). The unique property of pyrosequencing is that each allelic variant (homozygous, heterozygous) will give a specific pattern compared to the two other variants. The method is running in an automated microtiter-based pyrosequencer instrument, which allows a fast, accurate, flexible and sensitive detection of SNPs (Ahmadian *et al.*, 2000; Nordström *et al.*, 2000; Gut, 2001).

Pyrosequencing is a sequencing-by-synthesis method, based on the luminometric detection of pyrophosphate released upon nucleotide incorporation.

The pyrosequencing reaction (Figure 22) consists of a single-stranded, PCR amplified, DNA template containing the SNP position. Additionally, the mixture contained a short annealing primer, and four enzymes: DNA polymerase, ATP sulfurylase, luciferase and apyrase. After primer hybridisation, nucleotides were added stepwise in a calculated and defined manner, if it is incorporated into the new DNA strand pyrophosphate (PP_i) is released in proportion to the number of nucleotides being incorporated. ATP sulfurylase quantitatively converted PP_i to ATP, and luciferase used the ATP to generate detectable light. Real-time signals (height of peaks in a pyrogram) are corresponded to the number of incorporated nucleotides. Unreacted

nucleotides are degraded by the enzyme apyrase, allowing iterative addition of nucleotides (Ahmadian *et al.*, 2000; Benting *et al.*, 2004; Nordfors *et al.*, 2002).

Figure 22: Principle of pyrosequencing reaction

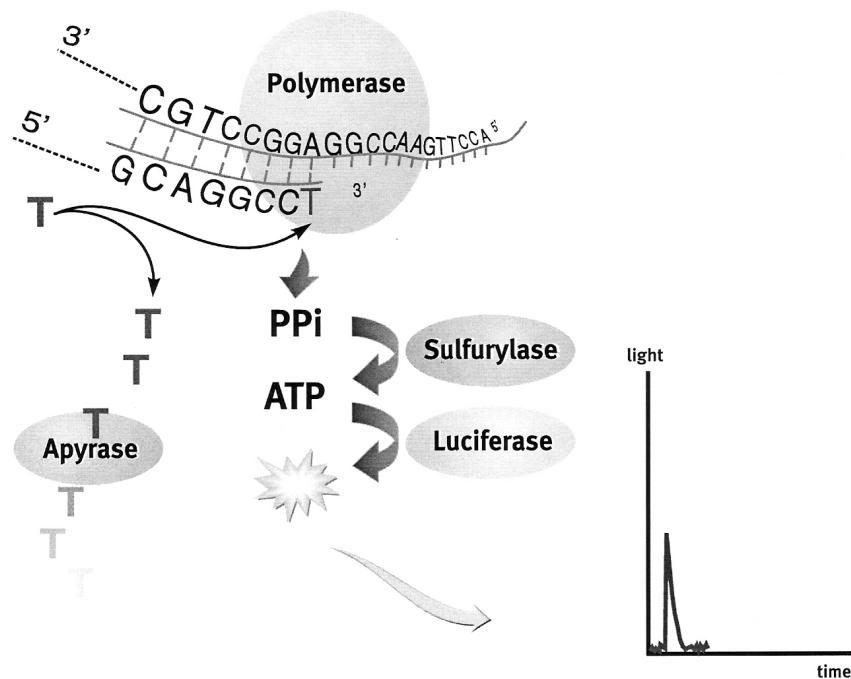

3.5.5.2 Pyrosequencing

The aim was the detection of the presence or absence of mutations in the sodium channel (called *kdr*- or *super-kdr*) in mass homogenates and single larvae of *S. exigua* strains (SPOD-EX S and E-98). For analysis of this SNP a pyrosequencing reaction was performed in a 45µl volume on an automated Pyrosequencer HS 96 instrument (Biotage, Upsalla, Sweden), following the manufacturer's instructions (Ahmadian *et al.*, 2000; Alon *et al.*, 2006). The gene region of interest was amplified using primer 276 and the biotinylated primer 277 (Table 10).

Table 10: Designed primers for pyrosequencing reaction

No.	Length (bp)	Name	Description	Sequence 5' - 3'
276	18	<i>S. exigua</i> Sodium Channel <i>kdr</i> Pyro f	Sense primer for PCR amplification of a region of <i>S. exigua</i> Na-channel Consensus S3 + S4 T7 -172	TCTTCCTGGCTACAGTCG
277	18	<i>S. exigua</i> Sodium Channel <i>kdr</i> Pyro r biotin	Antisense primer for PCR amplification of a region of <i>S. exigua</i> Na-channel Consensus S3 + S4 T7 -172	GACAGTAACAGGGCCAAG
278	15	<i>S. exigua</i> Sodium Channel <i>kdr</i> Pyro f Seq	Pyrosequencing Primer	CAGTCGTCATYGGCA

Degenerate Sequence: Y = T/C

r = reverse; f = forward

biotin = primer is biotinylated at the 5'-end

As a template genomic DNA from mass homogenate or single larvae was used, all material was from 3rd instar larvae. The extraction of total RNA was exactly carried out as described above (hot phenol extraction and RNeasy Mini Total RNA Isolation Kit). First-strand cDNA was synthesized from total RNA (5µg) with the iScript cDNA Synthesis Kit (BioRad, Munich, Germany). The reaction volume (20µl) consisted of 4µl Reaction Mix (5x), 1µl iScript reverse transcriptase, nuclease free water and the RNA. The first-strand cDNA was amplified starting with an annealing-step at 25°C for 5 min, followed by 42°C for 30 min (first-strand synthesis), and inactivation of the reverse transcriptase (85°C for 15 min).

PCR reactions were done using Qiagen HotStar Taq-polymerase. The thermal cycling conditions were 95°C for 15 min followed by 40 cycles of 95°C for 30 sec, 53°C for 45 sec, 72°C for 30 sec and a final extended incubation at 72°C for 7 min. The biotinylated PCR fragments were immobilized onto streptavidin beads (Pharmacia Biotech), and the DNA was denatured and the non-biotinylated strands were washed away. After neutralization, heating to 80°C, and cooling to room temperature, the sequencing primer 278 (Table 10) was added to the single stranded DNA-fragments, to prime the pyrosequencing reaction. A CCD camera detected the emission of light resulting from nucleotide incorporation. The software used to run the instrument run and analysis of the resulting pyrograms was PSQTM 96MA 2.0 from Biotage.

From each strain two mass homogenates and eight single larvae were analysed.

3.6 Statistics and calculations

All bioassay results were corrected by the formula of Abbott (1925) and expressed as % efficacy. ED_{50} - or $EC_{50/95/99}$ -values and their 95% confidential intervals (CI 95%) were calculated from probit regressions using the computer program POLO-PC (LeOra Software, Berkeley, CA, USA). Based on the results, resistance factors (RF) were calculated by dividing the EC_{50} -value of strain SPOD-EX E-98 by the EC_{50} -value of strain SPOD-EX S. Synergistic factors (SF) were calculated by dividing the ED_{50} -value obtained without synergist by the ED_{50} -value obtained with synergist application prior to insecticide treatment. Generally, averages were expressed as \pm standard error (SE).

The determination of statistical significance was done by utilizing GraphPad Prism version 4.0 software (GraphPad software, San Diego, CA, USA). Significant differences between the means of enzyme activity were evaluated by t-test, and P-values less than 0.05 were considered to be significant. Different biochemical characteristics of enzyme activities were calculated and analysed using GraphPad Prism version 4.0 software, and expressed in K_m and V_{max} -values or IC_{50} -values for inhibition studies.

4 RESULTS

4.1 Bioassays

4.1.1 Baseline susceptibility of *H. armigera* and *H. virescens* to different insecticides

The laboratory strains HELI-AR and HELI-VI served to establish the baseline susceptibility for several relevant lepidopteran insecticides by testing a full range of concentrations in order to compute dose-response relationships, and subsequently EC₅₀-values. Two bioassay techniques, a leaf-disc spray application (Table 11) and an artificial diet bioassay (Table 12), were used and compared, for measurement of the efficacy to twelve different insecticides in 2nd instar larvae. The susceptibility status of both strains to all compounds has not been exactly described yet; both strains were maintained in the laboratory since many years without insecticide treatments, thus regarded as susceptible reference strains.

In the spray bioassay (Table 11), the benzoylphenyl urea triflumuron showed the lowest efficacy; on the other hand emamectin was the most active insecticide against both strains (HELI-AR and HELI-VI). The new insecticide flubendiamide and the pyrethroid deltamethrin were slightly less effective than emamectin. Generally, the EC₅₀-values of the log-dose probit-efficacy lines ranged from ca. 0.05 (emamectin) to 880 mg litre⁻¹ (triflumuron). The rank order, as determined by their EC₅₀-value was from the most toxic compound to the least toxic. Three compounds exhibited an EC₅₀-value greater than 70 mg litre⁻¹, triflumuron followed by the two organophosphates methamidophos and triazophos. Furthermore, three compounds ranging between ca. 3 and 40 mg litre⁻¹, methoxyfenozide > thiodicarb > endosulfan. The remaining six insecticides are a very effective group against the two strains HELI-AR and HELI-VI, and exhibited EC₅₀-values of smaller than 3 mg litre⁻¹.

Table 11: Log-dose probit-efficacy data for several insecticides against 2nd instar larvae of strains HELI-AR and HELI-VI in a leaf disc bioassay treated by spray application (4d)

Compound	Strain	EC₅₀ mg litre⁻¹	CI 95%	Slope (SE)
Flubendiamide	HELI-AR	0.079	0.07 to 0.09	8.4 (0.89)
	HELI-VI	0.087	0.08 to 0.09	6.2 (0.68)
Deltamethrin	HELI-AR	0.15	0.10 to 0.24	2.4 (0.20)
	HELI-VI	0.15	0.10 to 0.22	2.8 (0.26)
Thiodicarb	HELI-AR	12.7	11.4 to 14.1	4.0 (0.40)
	HELI-VI	8.3	7.1 to 9.6	2.5 (0.20)
Methamidophos	HELI-AR	100.4	72.4 to 139.9	2.6 (0.23)
	HELI-VI	126.6	106.9 to 150.2	2.8 (0.27)
Triazophos	HELI-AR	69.6	64.2 to 75.8	5.8 (0.62)
	HELI-VI	136.2	119.8 to 157.1	3.0 (0.27)
Endosulfan	HELI-AR	17.6	15.2 to 20.4	3.9 (0.36)
	HELI-VI	39.0	33.6 to 45.3	3.7 (0.50)
Triflumuron	HELI-AR	339.1	283.7 to 405.4	2.5 (0.23)
	HELI-VI	880.8	646.0 to 1216	2.4 (0.22)
Indoxacarb	HELI-AR	0.25	0.18 to 0.42	3.5 (0.31)
	HELI-VI	0.17	0.15 to 0.19	4.1 (0.37)
Emamectin	HELI-AR	0.049	0.032 to 0.077	2.3 (0.19)
	HELI-VI	0.062	0.037 to 0.11	2.5 (0.22)
Spinosad	HELI-AR	2.1	1.4 to 3.2	2.8 (0.27)
	HELI-VI	0.60	0.40 to 0.96	2.7 (0.23)
Chlorfenapyr	HELI-AR	0.92	0.63 to 1.4	2.2 (0.18)
	HELI-VI	0.59	0.33 to 1.1	1.9 (0.15)
Methoxyfenozide	HELI-AR	8.8	7.1 to 11.6	3.7 (0.37)
	HELI-VI	3.3	2.7 to 4.0	2.2 (0.18)

Furthermore, all twelve insecticides were also tested in an artificial diet bioassay (Table 12) against both strains, HELI-AR and HELI-VI. Emamectin was also found in this bioassay format to be the most toxic compound ($EC_{50}=0.013$ mg litre⁻¹) followed by flubendiamide < deltamethrin < indoxacarb < spinosad < methoxyfenozide, all six insecticides showed an EC_{50} -value lower than 4 mg litre⁻¹. At the other extreme triazophos was the insecticide for which the highest EC_{50} -value was recorded, i.e. 123 and 91 mg litre⁻¹ against HELI-VI and HELI-AR, respectively. The efficacy level of the chitin biosynthesis inhibitor triflumuron was also relatively low, 76 and 71 mg litre⁻¹ (EC_{50}) against HELI-AR and HELI-VI, respectively. Furthermore, endosulfan, chlorfenapyr and methamidophos represent a group of insecticides with medium toxicity exhibiting EC_{50} -values of approx. 15 mg litre⁻¹.

The comparison of the two heliothine species, revealed that in general HELI-AR is either equal (overlapping CI 95%) or lesser susceptible than HELI-VI, with the notable exception of

endosulfan and triazophos in both types of bioassay. Flubendiamide turned out to be a little less active against both species when tested on artificial diet.

Table 12: Efficacy of several insecticides against 2nd instar larvae of strains HELI-AR and HELI-VI in an artificial diet bioassay (7d)

Compound	Strain	EC ₅₀ mg litre ⁻¹	CI 95%	Slope (SE)
Flubendiamide	HELI-AR	0.13	0.11 to 0.16	2.8 (0.26)
	HELI-VI	0.09	0.08 to 0.11	4.3 (0.56)
Deltamethrin	HELI-AR	0.20	0.17 to 0.23	3.9 (0.41)
	HELI-VI	0.19	0.16 to 0.23	2.9 (0.28)
Thiodicarb	HELI-AR	44.6	37.3 to 53.3	2.5 (0.23)
	HELI-VI	24.6	20.8 to 29.1	2.9 (0.27)
Methamidophos	HELI-AR	16.4	13.1 to 20.7	4.6 (0.42)
	HELI-VI	13.3	10.0 to 17.6	5.0 (0.48)
Triazophos	HELI-AR	90.9	76.2 to 108.3	2.6 (0.24)
	HELI-VI	122.6	103.4 to 145.6	2.8 (0.26)
Endosulfan	HELI-AR	12.6	11.0 to 14.9	4.6 (0.57)
	HELI-VI	29.5	16.9 to 53.1	2.3 (0.20)
Triflumuron	HELI-AR	75.5	65.6 to 88.3	4.9 (0.48)
	HELI-VI	70.7	61.6 to 82.7	4.6 (0.47)
Indoxacarb	HELI-AR	0.37	0.34 to 0.41	5.5 (0.69)
	HELI-VI	0.20	0.09 to 0.36	2.4 (0.19)
Emamectin	HELI-AR	0.013	0.011 to 0.015	3.7 (0.50)
	HELI-VI	0.014	0.012 to 0.016	3.4 (0.38)
Spinosad	HELI-AR	1.7	1.1 to 2.7	2.5 (0.22)
	HELI-VI	0.73	0.60 to 0.89	2.0 (0.17)
Chlorfenapyr	HELI-AR	16.0	13.7 to 19.0	5.8 (0.63)
	HELI-VI	14.2	12.3 to 16.8	5.2 (0.59)
Methoxyfenozide	HELI-AR	3.58	3.1 to 4.2	3.7 (0.34)
	HELI-VI	0.25	0.21 to 0.28	4.0 (0.54)

4.1.2 Resistance pattern in *Spodoptera exigua* strain SPOD-EX E-98

The spray and artificial diet bioassay were additionally used to test cross-resistance pattern of 2nd instar larvae of strain SPOD-EX E-98 in comparison to the susceptible reference strain SPOD-EX S. The generated dose-response data were used to calculate EC₅₀-values which were taken for the determination of resistance factors of strain SPOD-EX E-98.

In Table 13, the results of the leaf-disc spray bioassay are summarized. Resistance to deltamethrin and triflumuron was very high in strain SPOD-EX E-98 reaching RFs of 1063 and >84, respectively. Furthermore, both OPs methamidophos and triazophos were less efficacious in strain SPOD-EX E-98, and the resulting RFs were 17.8 and 23.9, respectively. Resistance factors calculated for indoxacarb (RF=21.3), endosulfan (RF=4.1) and thiodicarb (RF=6.4) were also moderate, but efficacy in the resistant strain SPOD-EX E-98 was still

good. Resistance was very low with resistance factors below 1.8 for the remaining five insecticides.

Flubendiamide was very active against both strains and no resistance was detected in strain SPOD-EX E-98 (RF 1.5). However, *S. exigua* larvae seem to be somewhat less susceptible compared with the heliothine species tested in the same bioassay format.

Table 13: Log-dose probit-efficacy data and resistance factors for several insecticides against two *Spodoptera exigua* strains. Second-instar larvae were tested on leaf discs treated by spray application (4d).

Compound	Strain	EC ₅₀ mg litre ⁻¹	CI 95%	Slope (SE)	RF*
Flubendiamide	SPOD-EX S	0.17	0.15 to 0.19	4.1 (0.37)	1.5
	SPOD-EX E-98	0.26	0.20 to 0.35	3.2 (0.28)	
Deltamethrin	SPOD-EX S	0.15	0.13 to 0.17	3.0 (0.29)	1063
	SPOD-EX E-98	159.4	126.4 to 202.7	1.5 (0.12)	
Thiodicarb	SPOD-EX S	23.9	20.2 to 28.2	2.9 (0.28)	6.4
	SPOD-EX E-98	151.7	115.5 to 192.6	2.6 (0.21)	
Methamidophos	SPOD-EX S	44.7	36.8 to 54.4	2.1 (0.18)	17.8
	SPOD-EX E-98	796.5	672.8 to 945.4	2.8 (0.27)	
Triazophos	SPOD-EX S	7.1	5.9 to 8.6	2.4 (0.21)	23.9
	SPOD-EX E-98	169.9	146.2 to 194.6	3.0 (0.26)	
Endosulfan	SPOD-EX S	113.3	97.3 to 131.0	3.9 (0.38)	4.1
	SPOD-EX E-98	463.9	387.4 to 556.1	2.5 (0.22)	
Triflumuron	SPOD-EX S	11.9	9.9 to 14.2	2.5 (0.22)	> 84.0
	SPOD-EX E-98	> 1000			
Indoxacarb	SPOD-EX S	0.16	0.13 to 0.19	2.3 (0.20)	21.3
	SPOD-EX E-98	3.4	3.1 to 3.8	4.2 (0.38)	
Emamectin	SPOD-EX S	0.069	0.057 to 0.083	2.3 (0.19)	1.3
	SPOD-EX E-98	0.091	0.065 to 0.13	1.6 (0.11)	
Spinosad	SPOD-EX S	1.0	0.81 to 1.1	4.0 (0.41)	1.8
	SPOD-EX E-98	1.8	1.3 to 2.4	2.7 (0.23)	
Chlorfenapyr	SPOD-EX S	3.1	2.6 to 3.6	2.8 (0.26)	1.2
	SPOD-EX E-98	3.8	2.1 to 7.0	2.3 (0.20)	
Methoxyfenozide	SPOD-EX S	0.86	0.75 to 1.0	6.6 (0.63)	1.6
	SPOD-EX E-98	1.4	1.1 to 1.6	2.3 (0.19)	

*RF = resistance factor, determined by dividing the EC₅₀ of strain E-98 by EC₅₀ of strain S

In the bioassay based on artificial diet (Table 14), strain SPOD-EX E-98 showed a strong resistance to the Type II pyrethroid insecticide deltamethrin (RF=708) and the non-ester pyrethroid etofenprox (RF=44.8). Compared to strain SPOD-EX S, SPOD-EX E-98 was also >5.5 and 28.7-fold less susceptible to the OPs methamidophos and triazophos, respectively.

One of the benzoylphenyl ureas tested, triflumuron, expressed a high RF of >46.3, but hexaflumuron exhibited a higher toxicity against the larvae of strain SPOD-EX E-98, and a somewhat lower RF of 22.6 was determined.

Interestingly, the additionally tested carbamate carbofuran showed a significant negative cross-resistance (RF<0.3) in strain SPOD-EX E-98, but not the other carbamate insecticide thiodicarb (RF>5.7). Strain SPOD-EX E-98 exhibits low resistance to indoxacarb (RF=3.7) and but was not responsive to endosulfan ($EC_{50}>1000\text{mg litre}^{-1}$; RF>5.4). Several EC-values and RFs were not exactly determined, because no efficacy on larvae at higher concentrations (e.g. $1000\text{ mg litre}^{-1}$) was recorded, e.g. endosulfan. Quite low, cross-resistance levels were obtained for spinosad, chlorfenapyr and methoxyfenozide, and no significant differences in efficacy to flubendiamide and emamectin were recorded relative to the susceptible strain.

In general, the two bioassay types revealed similar resistance patterns in strain SPOD-EX E-98. In contrast to the spray bioassay both *S. exigua* strains are generally less susceptible to the insecticides in an artificial diet bioassay, a result that matches the finding for the heliothine species.

Table 14: Efficacy and resistance of several insecticides against 2nd instar larvae of strains SPOD-EX S and SPOD-EX E-98 in an artificial diet bioassay (7d)

Compound	Strain	EC ₅₀ mg litre ⁻¹	CI 95%	Slope (SE)	RF*
Flubendiamide	SPOD-EX S	0.21	0.17 to 0.24	3.2 (0.31)	0.8
	SPOD-EX E-98	0.17	0.14 to 0.20	3.7 (0.36)	
Deltamethrin	SPOD-EX S	0.12	0.10 to 0.14	2.5 (0.22)	708
	SPOD-EX E-98	85.0	59.8 to 121.5	2.4 (0.21)	
Etofenprox	SPOD-EX S	7.3	6.3 to 8.6	3.4 (0.39)	44.8
	SPOD-EX E-98	327.1	274.5 to 387.4	2.6 (0.21)	
Thiodicarb	SPOD-EX S	174.1	132.0 to 209.5	4.3 (0.51)	> 5.7
	SPOD-EX E-98	> 1000			
Carbofuran	SPOD-EX S	> 2000			< 0.298
	SPOD-EX E-98	595.3	444.4 to 772.9	2.3 (0.17)	
Methamidophos	SPOD-EX S	183.0	137.4 to 246.3	3.0 (0.30)	> 5.5
	SPOD-EX E-98	> 1000			
Triazophos	SPOD-EX S	13.1	11.6 to 14.7	3.3 (0.32)	28.7
	SPOD-EX E-98	376.0	338.0 to 418.2	3.8 (0.36)	
Endosulfan	SPOD-EX S	186.7	120.1 to 296.8	3.1 (0.33)	> 5.4
	SPOD-EX E-98	> 1000			
Triflumuron	SPOD-EX S	21.6	18.2 to 25.7	2.7 (0.26)	> 46.3
	SPOD-EX E-98	> 1000			
Hexaflumuron	SPOD-EX S	1.1	0.90 to 1.33	2.3 (0.20)	22.6
	SPOD-EX E-98	24.9	20.5 to 30.4	2.0 (0.17)	
Indoxacarb	SPOD-EX S	1.1	0.93 to 1.26	3.9 (0.45)	3.7
	SPOD-EX E-98	4.1	3.0 to 5.4	2.3 (0.18)	
Emamectin	SPOD-EX S	0.007	0.006 to 0.008	3.4 (0.32)	1.0
	SPOD-EX E-98	0.007	0.006 to 0.009	2.8 (0.27)	
Spinosad	SPOD-EX S	1.4	1.0 to 1.7	3.5 (0.33)	1.8
	SPOD-EX E-98	2.5	2.2 to 2.9	4.5 (0.57)	
Chlorfenapyr	SPOD-EX S	12.3	10.7 to 14.5	4.5 (0.57)	1.8
	SPOD-EX E-98	21.6	18.6 to 25.0	4.1 (0.39)	
Methoxyfenozide	SPOD-EX S	0.31	0.27 to 0.36	3.4 (0.38)	2.2
	SPOD-EX E-98	0.68	0.58 to 0.80	3.0 (0.28)	

*RF = resistance factor, determined by dividing the EC₅₀ of strain E-98 by EC₅₀ of strain S

The artificial diet bioassay showed, compared with the spray bioassay against all three susceptible noctuid strains either equal or higher EC₅₀-values. Except for methamidophos, triflumuron and chlorfenapyr in strains HELI-AR and HELI-VI, and methoxyfenozide in strain SPOD-EX S. However, the artificial diet bioassay proves to be a more simple and robust than the leaf-disc spray bioassay, and therefore the artificial diet technique was used for further investigations, e.g. the monitoring study.

4.2 Efficacy of flubendiamide

4.2.1 Baseline susceptibility and stage-specific activity

Baseline monitoring of susceptibility of lepidopteran strains was done using 2nd instar larvae. Flubendiamide was used in the artificial diet bioassay in different concentrations, ranging from 0 to 100% efficacy in the test system (see Figure 23). First, no significant difference was observed between *S. exigua* strains SPOD-EX S and SPOD-EX E-98, although strain SPOD-EX E-98 shows resistance against several other insecticides. Generally, the variation of the EC₅₀-values of flubendiamide between all four strains was approx. 2-fold, suggesting a low degree of heterogeneity in response between species tested. The order of flubendiamide efficacy, expressed as EC₅₀-values, of the strains was SPOD-EX S > SPOD-EX E-98 > HELI-AR > HELI-VI.

Figure 23: Dose-response relationships for flubendiamide against 2nd instar larvae of four lepidopteran strains in an artificial diet bioassay (7d)

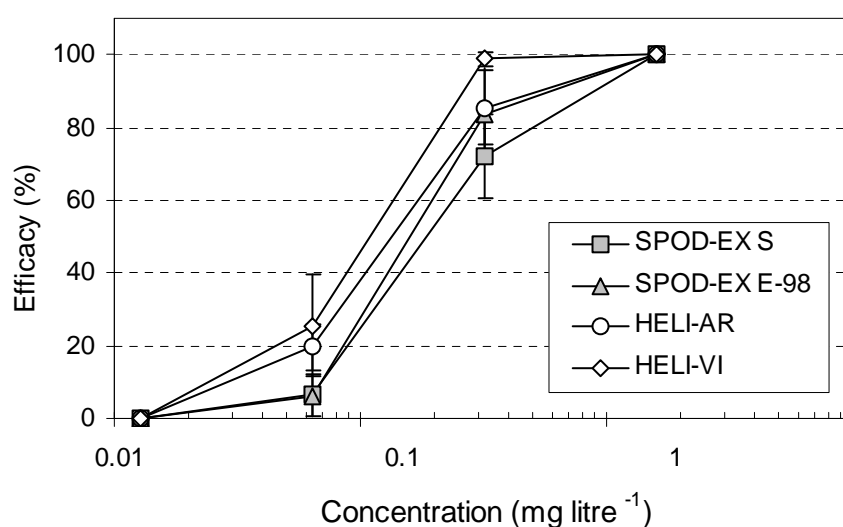

For the determination of the efficacy of flubendiamide against all five developmental instars of all four lepidopteran strains the artificial diet bioassay was chosen. Results are expressed as EC₅₀-values (incl. CI 95%) and shown in Figure 24.

The results indicated that flubendiamide was active against all instars, and the EC₅₀-values increased gradually from the 1st to 5th instar for all four noctuid strains. The EC₅₀-values determined for the different stages ranged roughly between 0.07 and 1 mg litre⁻¹, i.e. last instar larvae are ca. 11-fold less susceptible to flubendiamide than in the 1st instar larvae.

Assessment of the relative susceptibility within an instar revealed that larvae from both *S. exigua* strains are not significantly different in their response to flubendiamide. Strain

HELI-AR is a little more susceptible than both *S. exigua* strains, whereas strain HELI-VI showed the highest susceptibility towards flubendiamide.

Figure 24: Efficacy (expressed as EC₅₀-values) of flubendiamide against all larval stages of *Spodoptera exigua* (strains SPOD-EX S and E-98), *Helicoverpa armigera* (strain HELI-AR) and *Heliothis virescens* (strain HELI-VI). The horizontal error bars represent the CI 95%.

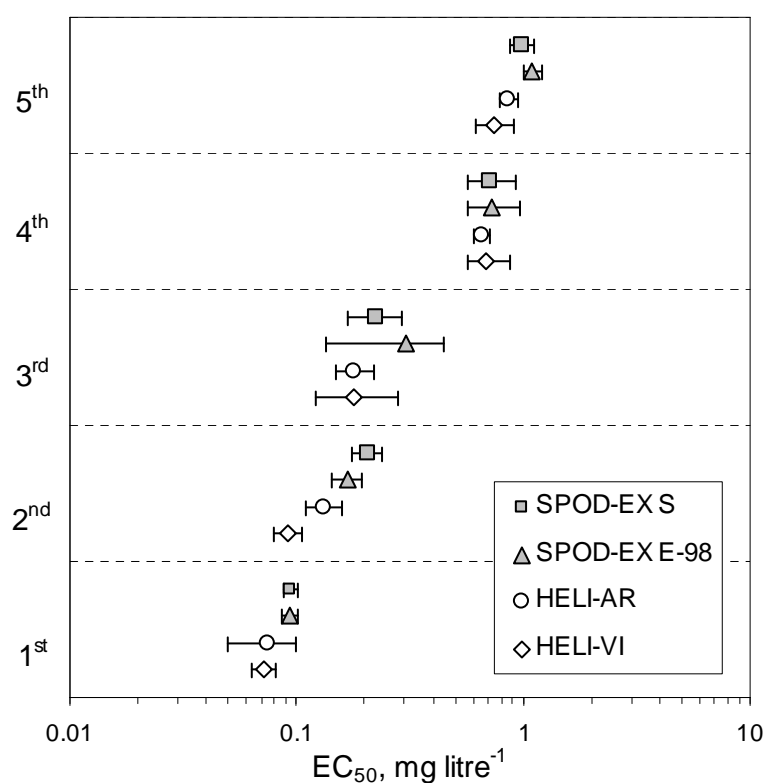

4.2.2 Worldwide monitoring

A global monitoring of flubendiamide susceptibility was done in different field-collected populations and laboratory strains of *S. exigua* and *H. armigera* larvae (between 2nd and beginning of the 3rd instar). For this purpose the artificial diet bioassay and one diagnostic concentration of the novel insecticide flubendiamide was used. The detailed procedure of the monitoring bioassay was described in section 3.3.3.

The diagnostic concentration of flubendiamide chosen is based on the effect against three laboratory strains (Table 15). The EC₉₅- and EC₉₉-values of flubendiamide against the three laboratory strains did not differ significantly (based on overlapping of CI 95%). The overall composite EC₉₉-value was 0.98 mg litre⁻¹ (CI 95%: 0.71-1.52), and finally a diagnostic concentration of 1 mg litre⁻¹ flubendiamide was chosen for the worldwide monitoring.

Table 15: Log-dose probit-efficacy data for flubendiamide in artificial diet bioassays against 2nd instar larvae

Strain	EC ₉₅ mg litre ⁻¹	CI 95%	EC ₉₉ mg litre ⁻¹	CI 95%	Slope (SE)
SPOD-EX S	0.68	0.54 to 0.96	1.12	0.82 to 1.75	3.15 (0.31)
SPOD-EX E-98	0.47	0.38 to 0.61	0.71	0.55 to 1.02	3.72 (0.36)
HELI-AR	0.51	0.40 to 0.73	0.90	0.64 to 1.44	2.80 (0.26)
Composite	0.58	0.45 to 0.81	0.98	0.71 to 1.52	3.02 (0.29)

The efficacy monitoring was carried out in 5 countries and 14 field populations and 4 laboratory strains (Table 16; see also Appendix A) were tested. Twelve strains responded fully susceptible (100% efficacy) to the diagnostic concentration of 1 mg litre⁻¹. Three populations of *S. exigua* and one laboratory strain of *H. armigera* showed a slight variation in their response to flubendiamide (83 to 92% efficacy).

The susceptibility of Spanish strains of *S. exigua* No. B (67%) and *H. armigera* No. A (65%) was somewhat lower. Nevertheless, the combined overall percentage efficacy of all monitored strains and populations was 93.2% (SD 11.6).

Table 16: Worldwide Monitoring: Efficacy of flubendiamide (1 mg litre⁻¹) against larvae of *Spodoptera exigua* and *Helicoverpa armigera* (+ Appendix A)

Species	Country	No.	Crop	Date bioassay	Dead or non-developed larvae	Treatment History
<i>Spodoptera exigua</i>	Spain	A	Melon	30/06/04	83%	Nomolt (Teflubenzuron), Mimic (Tebufenozide)
		B	Eggplant	01/06/04	67%	Match (Lufenuron), Delfin (Bt ^a), Alfa-cypermethrin
		C	Cucumber	07/07/04	100%	Pyrethroids
		D	Pepper	06/08/04	100%	Bt ^a , Soap
		E	Pepper (Green-House)	30/08/04	88%	Bt ^a
		F	Tomato	06/10/04	100%	Lannate (Methomyl)
		G	Tomato	06/10/04	100%	Lannate, Bt ^a , Decis (Deltamethrin)
		H	Pea	26/10/04	100%	Bt ^a + Decis, Spinosad, Chlorpyrifos + Decis
	Thailand	A	Chinese kale	01/07/04	100%	Multi-resistance (OP ^b , Pyrethroids, IGR ^c)
	Mexico	A	Corn	01/07/04	100%	Chlorpyrifos
Turkey	A	Corn	23/06/04	83%	No chemical applied before	
<i>Helicoverpa armigera</i>	Spain	A	Cotton	27/07/04	65%	Endosulfan, Methomyl
		B	Cotton	05/08/04	100%	Endosulfan, Methomyl
	Turkey	A	Cotton	20/07/04	100%	No chemical applied before
	Australia	A	Lab strain	09/06/04	92%	susceptible
		B	Lab strain	09/06/04	100%	Fenvalerate
		C	Lab strain	09/06/04	100%	Bifenthrin
		D	Lab strain	09/06/04	100%	Methomyl

^a *Bacillus thuringiensis*, ^b Organophosphates, ^c Insect growth regulators

4.3 Application and synergism studies

The effect of three different synergists was tested on deltamethrin, triflumuron and flubendiamide efficacy on strains SPOD-EX S and SPOD-EX E-98 (Table 17). Both, synergists and insecticides, were applied topically on 16-24h old 5th instar larvae. The synergist piperonyl butoxide (PBO) is a cytochrome P₄₅₀-dependent monooxygenase inhibitor, S,S,S-tributyl-phosphorotrithioate (DEF) and the organophosphorous insecticide profenofos are known to inhibit carboxylesterase activity. All three synergists were used in the highest possible concentration with no effect on toxicity to the two *S. exigua* strains, i.e. 30, 15 and 1 µg per larva for PBO, DEF and profenofos, respectively.

Strain SPOD-EX E-98 exhibited high resistance levels to deltamethrin and triflumuron, resulting in resistance ratios of 590- and >44-fold, respectively. Interestingly, strain SPOD-EX E-98 was slightly more susceptible to flubendiamide compared to strain SPOD-EX S, resulting in a resistance factor of 0.6.

Larval pre-treatment with synergists resulted in low to moderate synergistic effects (SF=0.8 to 3.5) to all three insecticides in both strains. However pre-treatment with PBO resulted in a significant increase of deltamethrin efficacy in strain SPOD-EX E-98 (SF=30), suggesting metabolic degradation via cytochrome P₄₅₀-dependent monooxygenases.

The lowest synergistic effect was observed for triflumuron in strain SPOD-EX S, the ED₅₀-value increased from 138ng/larva to 303ng/larva upon pre-treatment with PBO. None of the synergists reduced the resistance to triflumuron in strain SPOD-EX E-98.

Table 17: Synergistic effect of PBO (30 µg/larva), DEF (15 µg/larva) and profenofos (1 µg/larva) on flubendiamide, deltamethrin and triflumuron efficacy against strains SPOD-EX S and SPOD-EX E-98 of *Spodoptera exigua*

Strain	Compound + Synergist	ED ₅₀ ng	CI 95%	Slope (SE)	SF*	RF*
SPOD-EX S	Flubendiamide	793	534 to 1192	1.7 (0.12)		
	+ PBO	224	146 to 345	1.7 (0.11)	3.5	
	+ Profenofos	561	365 to 863	1.6 (0.11)	1.4	
	+ DEF	790	569 to 1105	1.8 (0.12)	1.0	
SPOD-EX E-98	Flubendiamide	458	248 to 825	1.7 (0.11)		0.6
	+ PBO	231	145 to 375	1.6 (0.11)	2.0	
	+ Profenofos	513	337 to 780	1.7 (0.11)	0.9	
	+ DEF	597	440 to 813	2.2 (0.16)	0.8	
SPOD-EX S	Deltamethrin	19	13 to 27	2.2 (0.16)		
	+ PBO	10	7.1 to 14	2.6 (0.20)	1.9	
	+ Profenofos	8.0	5.4 to 12	1.6 (0.10)	2.4	
	+ DEF	12	9.7 to 16	1.7 (0.11)	1.6	
SPOD-EX E-98	Deltamethrin	11202	4637 to 23857	1.3 (0.08)		590
	+ PBO	373	212 to 692	1.7 (0.12)	30.0	
	+ Profenofos	11881	4452 to 28087	1.2 (0.07)	0.9	
	+ DEF	10506	4132 to 22579	1.4 (0.08)	1.1	
SPOD-EX S	Triflumuron	138	118 to 161	2.4 (0.18)		
	+ PBO	303	224 to 411	2.3 (0.17)	0.5	
	+ Profenofos	68	52 to 88	1.8 (0.12)	2.0	
	+ DEF	96	68 to 134	1.8 (0.12)	1.4	
SPOD-EX E-98	Triflumuron	> 6000				> 44
	+ PBO	> 6000				
	+ Profenofos	> 6000				
	+ DEF	> 6000				

*SF = synergistic factor, determined by dividing the ED₅₀ of strain without synergist by ED₅₀ of strain with synergist application

*RF = resistance factor, determined by dividing the ED₅₀ of strain E-98 by ED₅₀ of strain S

4.4 Biochemical assays

In many cases, the most important mechanism of insecticide resistance is the metabolic degradation of chemical compounds. The enzymes involved in the detoxification of insecticides are usually overexpressed. Three major enzyme groups, i.e. esterases, glutathione S-transferases and monooxygenases are normally involved in metabolic resistance to insecticides.

In the following part, these major enzyme families were studied in both *S. exigua* strains (SPOD-EX S and E-98).

4.4.1 Glutathione S-transferases

4.4.1.1 Photometric assay in larvae mass homogenates

In Figure 25 the glutathione S-transferase activity towards 1-chloro-2,4-dinitrobenzene (CDNB) is shown in box-and-whisker plots. No significant differences ($p < 0.05$, t-test) were observed between both strains when the activity of glutathione S-transferases was measured in mass homogenates.

The average glutathione S-transferase activity in strain SPOD-EX S (385 ± 18 nmol/min/mg protein) was slightly lower compared with strain SPOD-EX E-98 (488 ± 40 nmol/min/mg protein), resulting in a 1.3-fold difference in activity.

Figure 25: Glutathione S-transferase activity in mass homogenates (2nd instar) of *Spodoptera exigua* strains SPOD-EX S and SPOD-EX E-98 determined with 1-chloro-2,4-dinitrobenzene (CDNB) as substrate

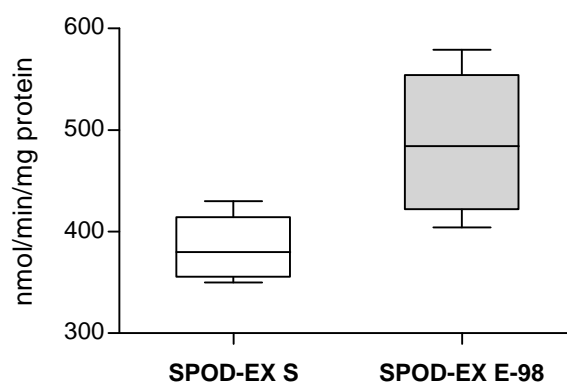

4.4.1.2 Frequency distribution of enzyme activity of single larvae

Glutathione S-transferase activity in individual susceptible and resistant larvae ($n=50$) was measured by conjugation of the artificial substrate CDNB with GSH, and showed overlapping Gaussian distribution curves of the two populations (Figure 26).

Individual larvae of the susceptible strain SPOD-EX S showed an activity range between 194 and 386 nmol/min/mg protein, expressing a quite homogenous Gaussian distribution of activity. The resistant strain SPOD-EX E-98 exhibited a glutathione S-transferase activity between 219 and 854 nmol/min/mg protein, thus resulting in a Gaussian distribution with a higher maximum compared to strain SPOD-EX S. Finally, forty-eight percent of the individual larvae of strain SPOD-EX E-98 showed a glutathione S-transferase activity overlapping with those activities measured in the susceptible strain.

The average activity in strain SPOD-EX E-98 (436 nmol/min/mg protein) was only 1.6-fold higher than that in strain SPOD-EX S (280 nmol/min/mg protein). At the same time, the results of glutathione S-transferase activity in mass homogenates showed a similar result, 1.3-fold difference between SPOD-EX S and SPOD-EX E-98.

Figure 26: Frequency distribution of glutathione S-transferase activity in 50 individual larvae (2nd instar) of strain SPOD-EX S and SPOD-EX E-98 of *Spodoptera exigua* (Gaussian distribution for each strain on the right)

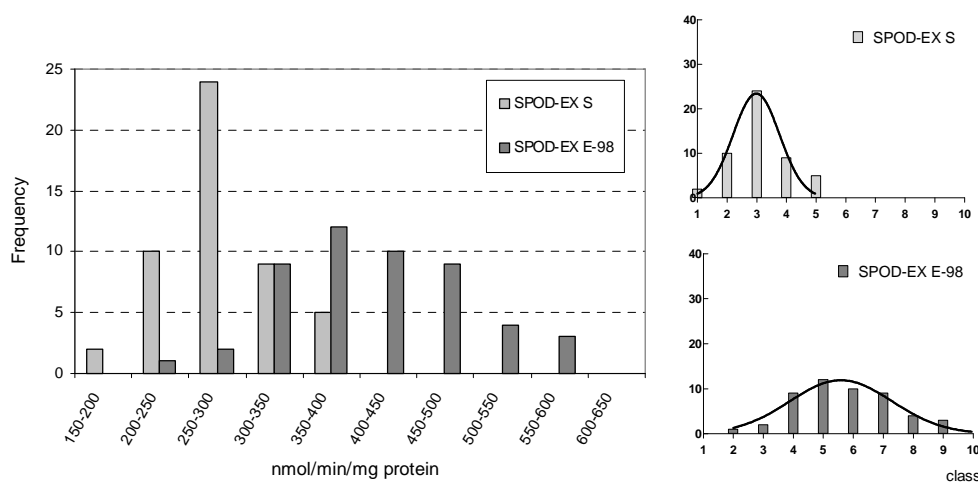

4.4.1.3 Fluorometric assay with monochlorobimane

The results in Figure 27 show the glutathione S-transferase activity obtained with another substrate, monochlorobimane (MCB), in the two strains of *S. exigua*. Strains SPOD-EX S and SPOD-EX E-98 exhibited a glutathione S-transferase activity of 192 ± 25 and 246 ± 39 fluorescence units/20min/ μ g protein, respectively. The more sensitive fluorometric assay revealed also no marked differences ($p < 0.05$, t-test) between glutathione S-transferase activity in strains SPOD-EX S and SPOD-EX E-98, and similarly to the results obtained with CDNB as a substrate the difference between strains was also 1.3.

However, using two different biochemical assays, no significant differences in activity between strains SPOD-EX S and SPOD-EX E-98 were found. Therefore, glutathione S-transferase activity as metabolic detoxification mechanism was not further investigated in this study.

Figure 27: Glutathione S-transferase activity measured with monochlorobimane (MCB) in mass homogenates of 2nd instar larvae of strains SPOD-EX S and SPOD-EX E-98

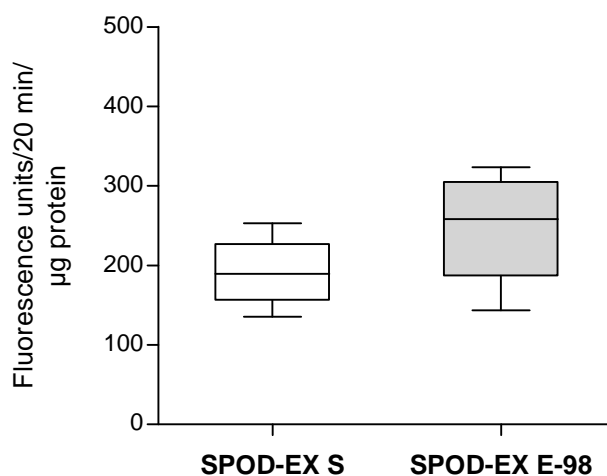

4.4.2 Carboxylesterases

4.4.2.1 Standard assay in larvae mass homogenates

The enzyme family of carboxylesterases is often determined in the literature in a photometric assay using the artificial substrate 1-naphthyl acetate. The released product 1-naphthol can easily be detected upon binding to a diazonium salt (Fast blue RR) at 450nm. The standard curve is shown in Figure 28 and was established with 1-naphthol using concentrations between 0.25 and 2.5nmol.

Figure 28: Standard curve obtained for 1-naphthol ($n=3$)

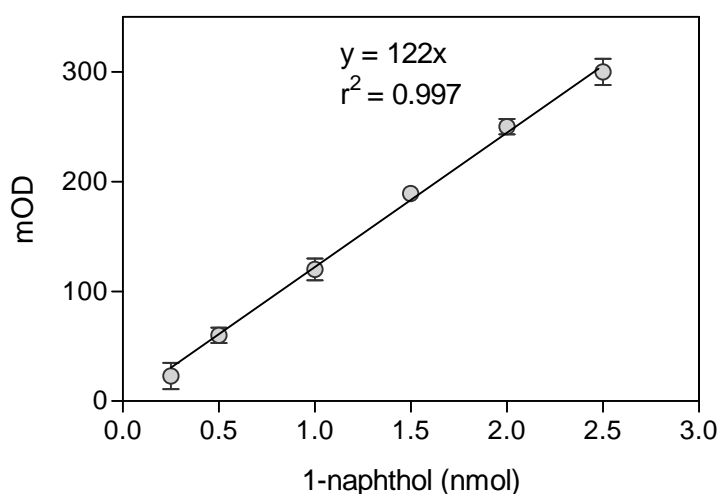
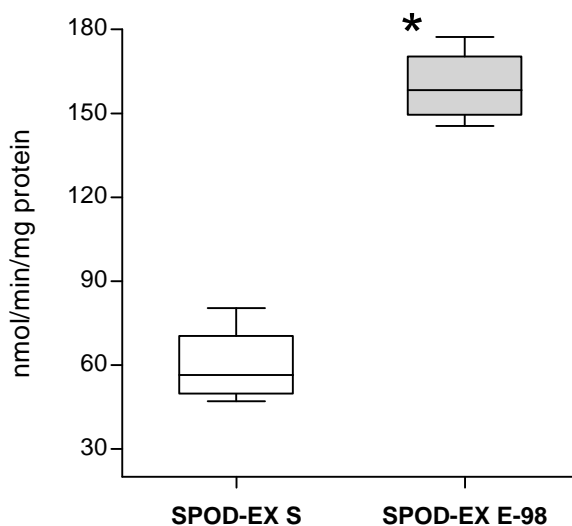

Figure 29 shows the carboxylesterase activity in mass homogenates of strains SPOD-EX S and SPOD-EX E-98 using 1-naphthyl acetate as artificial substrate.

The carboxylesterase activity in strain SPOD-EX E-98 (160 ± 7 nmol/min/mg protein) was 2.7-fold greater than in susceptible strain SPOD-EX S (60 ± 7 nmol/min/mg protein).

Figure 29: Carboxylesterase activity towards 1-naphthyl acetate in mass homogenates (2nd instar) of strains SPOD-EX S and SPOD-EX E-98 (* indicates significant differences compared with strain SPOD-EX S ($p < 0.05$, t-test, $n=4$))



Additionally, the carboxylesterase activity in mass homogenates was inhibited with a single concentration of the esterase inhibitor DEF. The average of the remaining activity in percent ($n=3$) was determined using a pre-incubation (10 min) of the enzyme source with 100 μ M DEF. The results were similar in both strains: $37 \pm 2\%$ and $41 \pm 10\%$ inhibition for strains SPOD-EX S and SPOD-EX E-98, respectively.

4.4.2.2 Frequency distribution of enzyme activity of single larvae

The photometric assay using 1-NA allowed the measurement the carboxylesterase activity in individual 2nd instar larvae, using 50 individuals each (Figure 30).

The frequency distribution of esterase activity in strain SPOD-EX E-98 was scattered (range: 77 to 238 nmol/min/mg protein) and 21 individuals overlapped with the more homogeneous Gaussian distribution of strain SPOD-EX S, varying between 33 and 149 nmol/min/mg protein.

The individual larvae of strains SPOD-EX S and SPOD-EX E-98 showed an average carboxylesterase activity of 77 and 159 nmol/min/mg protein, respectively: this was in

average a 2.1-fold increase in the resistant population. These data are comparable with the results of activity measurements of mass homogenates in both strains.

Figure 30: Frequency distribution of carboxylesterase activity measured with 1-naphthyl acetate in strains SPOD-EX S and SPOD-EX E-98 ($n=50$).

Insert on the right: Gaussian distribution for each strain.

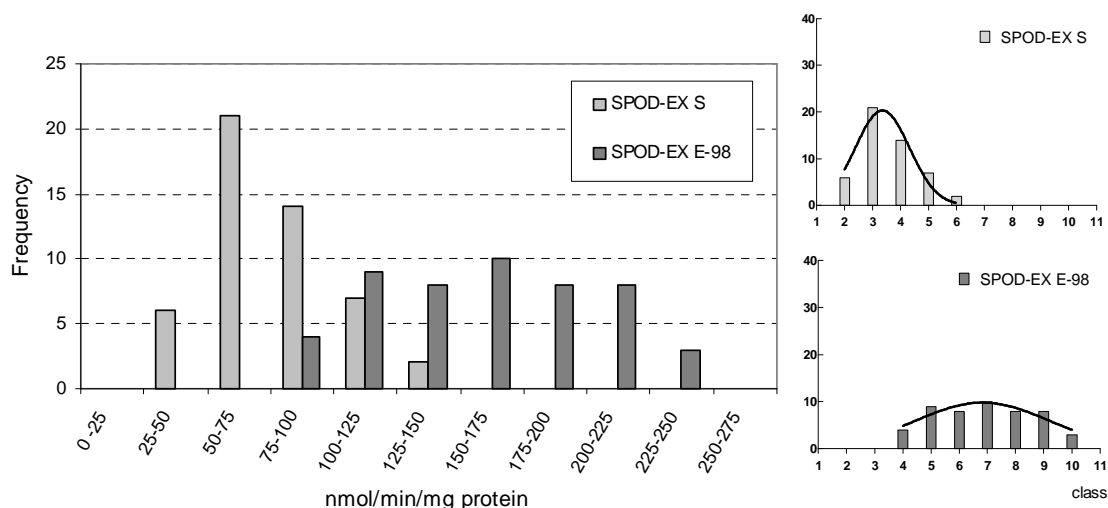

4.4.2.3 Carboxylesterase iso-enzyme analysis and inhibition visualised by nPAGE

Carboxylesterases are one of the important metabolic systems. Therefore, it was decided to have a close look at the characteristic enzyme-banding pattern of both *S. exigua* strains.

The carboxylesterase iso-enzyme banding patterns were separated by native polyacrylamide gel electrophoresis (nPAGE) of homogenates of 2nd instar larvae of *S. exigua* strains SPOD-EX S and SPOD-EX E-98. Furthermore, *in vitro* inhibitory effects of different insecticides and synergists on separated esterases are shown in Figure 31. The gels for the inhibition study were pre-incubated for 10 min in buffer with potential inhibitors diluted in acetone, and the different final concentrations are displayed in Table 8. The carboxylesterase bands were visualised using 1-naphthyl acetate (final conc. 0.6mM) as substrate and Fast blue RR. The gels were not running simultaneously, resulting in small variations among banding patterns and staining colours including the background.

There were some intriguing differences in the general banding patterns of carboxylesterase nPAGE between strains SPOD-EX S and SPOD-EX E-98 (control in Figure 31, panel A). Most bands were common in both strains, the resistant strain SPOD-EX E-98 lacked two bands (black arrows) found in the susceptible strain. On the other hand, strain SPOD-EX E-98 showed one small band and one with remarkably high activity (red arrows); however, both bands are lacking in strain SPOD-EX S.

Three synergists were used for investigation of *in vitro* inhibition of carboxylesterases pattern. PBO exhibited no inhibition of bands in both strains at a final concentration of 1mM, but the carboxylesterase inhibitor and organophosphate profenofos was quite active at a low concentration (0.1mM) resulting in a complete inhibition of all bands (both gels are not shown).

The inhibition profile of the synergist DEF (final conc. 1mM) is shown in Figure **31**, panel **A**. In both strains, the upper part of the gel is slightly and the lower part is completely inhibited. Interestingly, in the resistant strain SPOD-EX E-98 one band (red arrow) is unaffected by the inhibitory potential of DEF.

The two used acetylcholinesterase standard inhibitors, BW284c51 (final conc. 0.03mM) and eserine (final conc. 0.3mM) exhibited no inhibitory effect on the esterase nPAGE pattern in both strains (gels are not shown).

Moreover, the effects of different insecticides were also investigated on esterases separated by nPAGEs. Two pyrethroids, deltamethrin (Figure **31**, panel **A**) and etofenprox (gel is not displayed) did not show any effect on the enzyme banding pattern in both strains, using final concentrations of 0.3mM and 0.03mM, respectively.

As outlined in panel **B** of Figure **31**, the insecticide triazophos fully inhibited of fast running esterases in the lower part of the gels of both strains, whereas carbofuran showed only a slight inhibition potential in the same area. The second carbamate thiodicarb also expressed only a slight inhibition of esterases in the lower part of the gels.

Figure 31: *In vitro* inhibition in nPAGE gels of carboxylesterases of strains SPOD-EX S and SPOD-EX E-98 of *Spodoptera exigua* (1.5 larva equivalents per well) using 1-naphthyl acetate as substrate.

A. control, DEF (synergist) and deltamethrin (pyrethroid)

B. triazophos (OP), thiodicarb and carbofuran (carbamates).

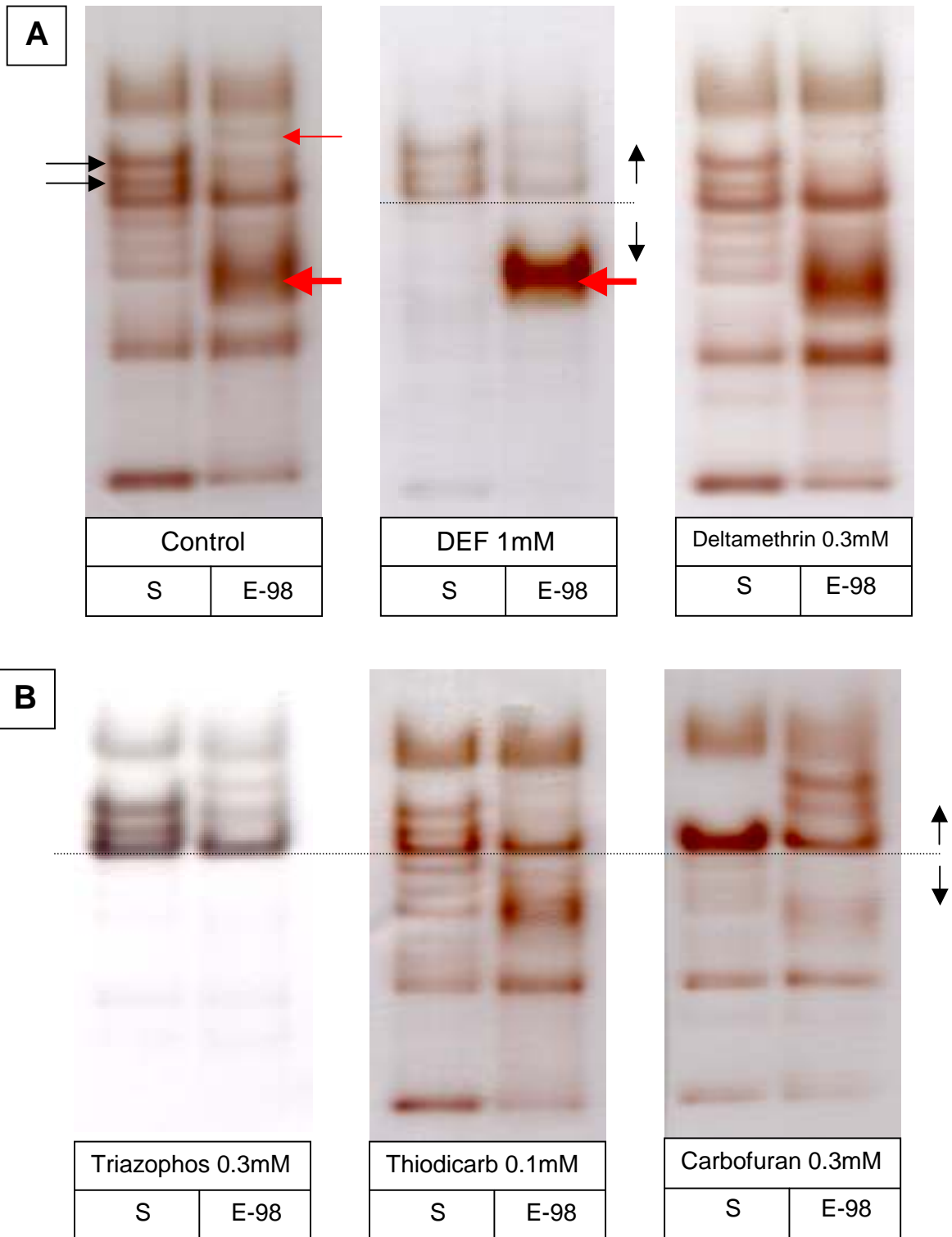

4.4.3 Cytochrome P₄₅₀-dependent monooxygenases

4.4.3.1 Fluorometric assay with 7-ethoxycoumarin in second-instar larvae

Cytochrome P₄₅₀-dependent monooxygenase activity was determined with a highly sensitive method using the artificial substrate 7-ethoxycoumarin which in the course of the reaction is O-deethylated to the fluorescent product umbelliferone (7-hydroxycoumarin).

The standard curve in Figure 32 shows linearity of the reaction between 1.6 and 100 pmol of 7-hydroxycoumarin.

Figure 32: Standard curve obtained for 7-hydroxycoumarin ($n=4$)

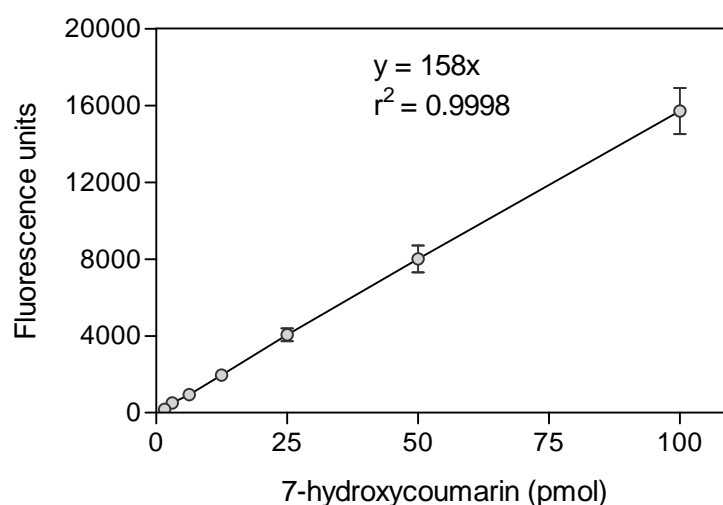

The activity of cytochrome P₄₅₀-dependent O-deethylation was detected in mass homogenates of decapitated larvae (2nd instar) using the artificial substrate 7-ethoxycoumarin in a fluorometric assay (Figure 33); the detection of the monooxygenase activity using complete larvae was not possible.

The average activity in strain SPOD-EX E-98 (1620 ± 284 pmol/30 min/mg protein) was significantly higher than in strain SPOD-EX S (197 ± 37 pmol/30 min/mg protein), resulting in a difference of 8.2-fold.

These results suggested that cytochrome P₄₅₀-dependent monooxygenases are most likely involved in the resistance mechanisms of the multi-resistant strain SPOD-EX E-98.

Figure 33: Cytochrome P₄₅₀-dependent monooxygenase (O-deethylation) activity towards 7-ethoxycoumarin in decapitated 2nd instar larvae of strains SPOD-EX S and SPOD-EX E-98 (* indicates significant differences compared with strain SPOD-EX S (p<0.05, t-test, n=4))

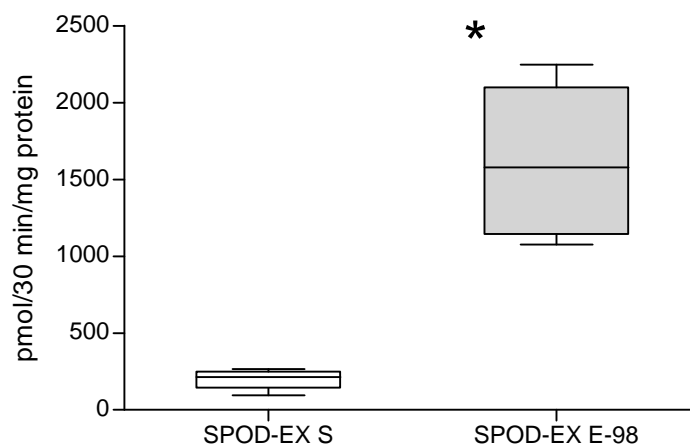

The O-deethylation activity was additionally inhibited by PBO, an inhibitor for cytochrome P₄₅₀-dependent monooxygenases, in both *S. exigua* strains. The average activity remaining (expressed in %, n=3) in the presence of 1mM PBO in the reaction mixture was $67 \pm 3\%$ and $45 \pm 10\%$ for strains SPOD-EX S and SPOD-EX E-98, respectively.

4.4.3.2 Monooxygenase activity in isolated guts of fifth-instar larvae

The activity of cytochrome P₄₅₀-dependent O-deethylation was also measured in microsomal fractions obtained from gut tissue of freshly ecdysed 5th instar larvae.

Microsomal gut fractions of strains SPOD-EX S and SPOD-EX E-98 showed an O-deethylation activity of 184 ± 28 and 1076 ± 55 pmol/30 min/mg protein, respectively (Figure 34).

Figure 34: Microsomal O-deethylation activity in strains SPOD-EX S and SPOD-EX E-98 determined using 7-ethoxycoumarin as artificial substrate. Microsomes were prepared from guts of freshly ecdysed 5th instar larvae. (* indicates significant differences compared with strain SPOD-EX S ($p < 0.05$, t-test, $n=4$))

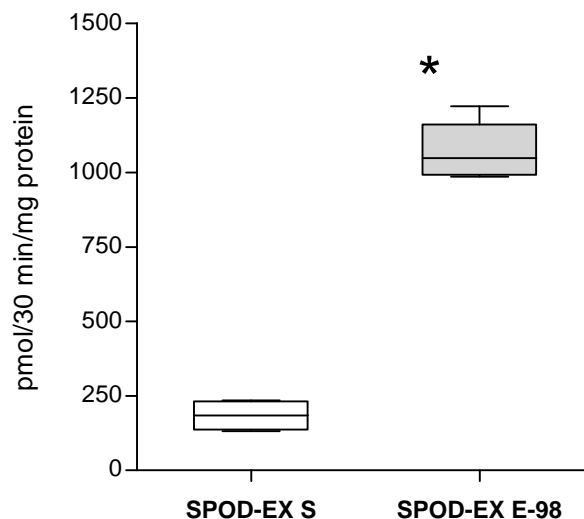

4.4.4 Acetylcholinesterases

4.4.4.1 Standard assay in larvae mass homogenates

The acetylcholinesterase activity of the two *S. exigua* strains measured in mass homogenates (2nd instar larvae) is shown in Figure 35. Strains SPOD-EX S and SPOD-EX E-98 exhibited an average acetylcholinesterase activity of 784 ± 55 and 1686 ± 111 mOD/min/mg protein, respectively. Thus the activity of acetylcholinesterase was significantly lower (2.2-fold) in the susceptible strain SPOD-EX S compared with the multi-resistant strain SPOD-EX E-98.

Figure 35: Acetylcholinesterase activity in mass homogenates of *Spodoptera exigua* strains SPOD-EX S and SPOD-EX E-98 (2nd instar) (* indicates significant differences compared with strain SPOD-EX S ($p < 0.05$, t-test, $n = 4$))

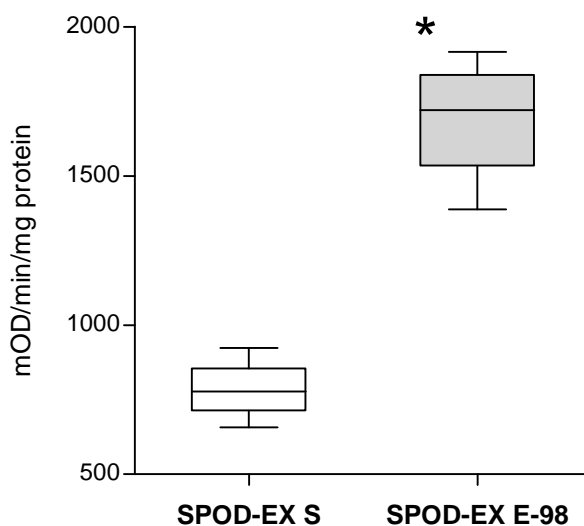

4.4.4.2 Frequency distribution of enzyme activity of single larvae

Acetylcholinesterase activity determination in individual larvae was conducted in 3rd instar larvae of both strains. The susceptible strain SPOD-EX S and the resistant strain SPOD-EX E-98 could be clearly separated by their acetylcholinesterase activity patterns ($n = 50$, frequency distribution) as shown in Figure 36.

It seems that acetylcholinesterase activity in single larvae was more homogeneous in strain SPOD-EX S (315 - 752 mOD/min/mg protein). However, in strain SPOD-EX E-98 the activity was more heterogeneous, i.e. ranging from 1040 to 3144 mOD/min/mg protein.

The average activity in strain SPOD-EX S (512 mOD/min/mg protein) was 3.5-fold lower compared with the resistant strain SPOD-EX E-98 (1764 mOD/min/mg protein). In comparison, acetylcholinesterase activity measured in mass homogenates of 2nd instar larvae was 2.2-fold higher in the resistant strain than in the susceptible strain, but the activities for the two different instars ranged in the same area.

Figure 36: Frequency distribution of acetylcholinesterase activity measured in homogenates of individual larvae of two *Spodoptera exigua* strains. The sample size for both strains was 50 larvae (3rd instar).

Insert: Gaussian distribution for each strain.

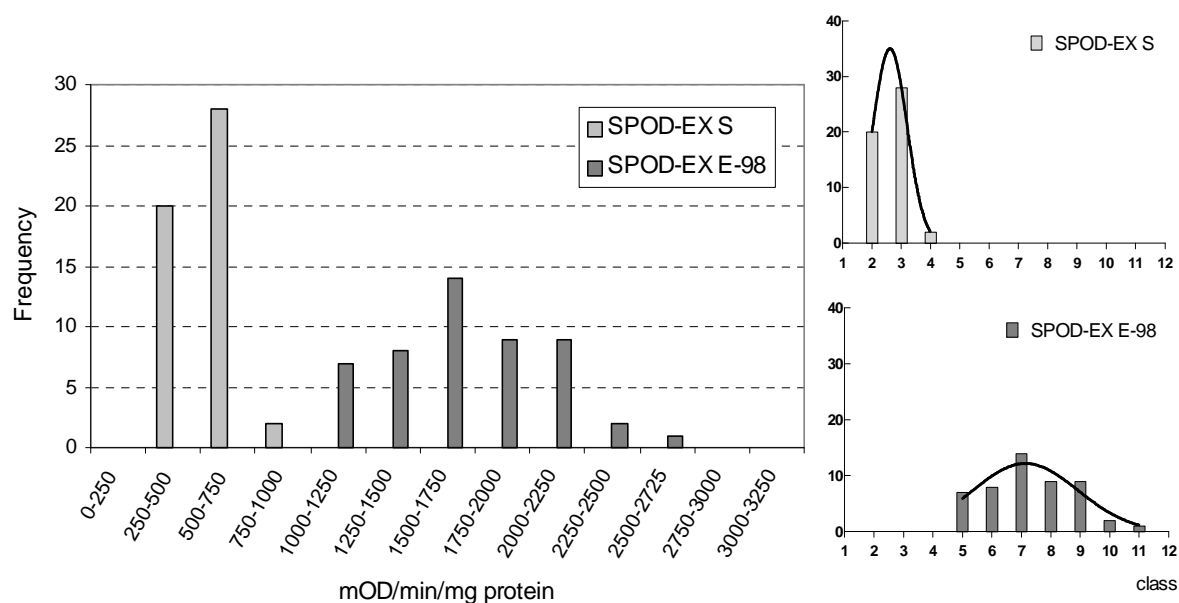

4.4.4.3 Michaelis-Menten kinetics

Kinetic parameters of acetylcholinesterase were determined in mass homogenates (2nd instar) of the susceptible strain SPOD-EX S and the resistant strain SPOD-EX E-98 using six different concentrations of the substrate ATChI, and expressed as Michaelis-Menten plots (Figure 37; left). Additionally, the observed data were plotted as $1/v$ against $1/s$ (Lineweaver-Burk plots) as shown in Figure 37 (right). The Michaelis-Menten constant (K_m) and maximum velocity (V_{max}) was determined for ATChI using Michaelis-Menten plots.

The observed results revealed differences between strains SPOD-EX S and SPOD-EX E-98. V_{max} reached 1299 ± 144 mOD/min/mg protein in the mass homogenate of strain SPOD-EX S compared with 2821 ± 68 mOD/min/mg protein for acetylcholinesterase of strain SPOD-EX E-98, i.e. representing a 2.2-fold higher activity in strain SPOD-EX E-98.

Strain SPOD-EX S showed a 1.5-fold higher K_m -value ($211 \pm 88\mu\text{M}$) compared with strain SPOD-EX E-98 ($140 \pm 14\mu\text{M}$), indicating an increase in the affinity of the enzyme acetylcholinesterase from strain SPOD-EX E-98.

Figure 37: Michaelis-Menten and Lineweaver-Burk plots (right) of acetylcholinesterases from *Spodoptera exigua* strains SPOD-EX S and SPOD-EX E-98 using six concentrations of acetylthiocholine iodide (ATChI) as substrate (Data and equation of graphs are described in Appendix C)

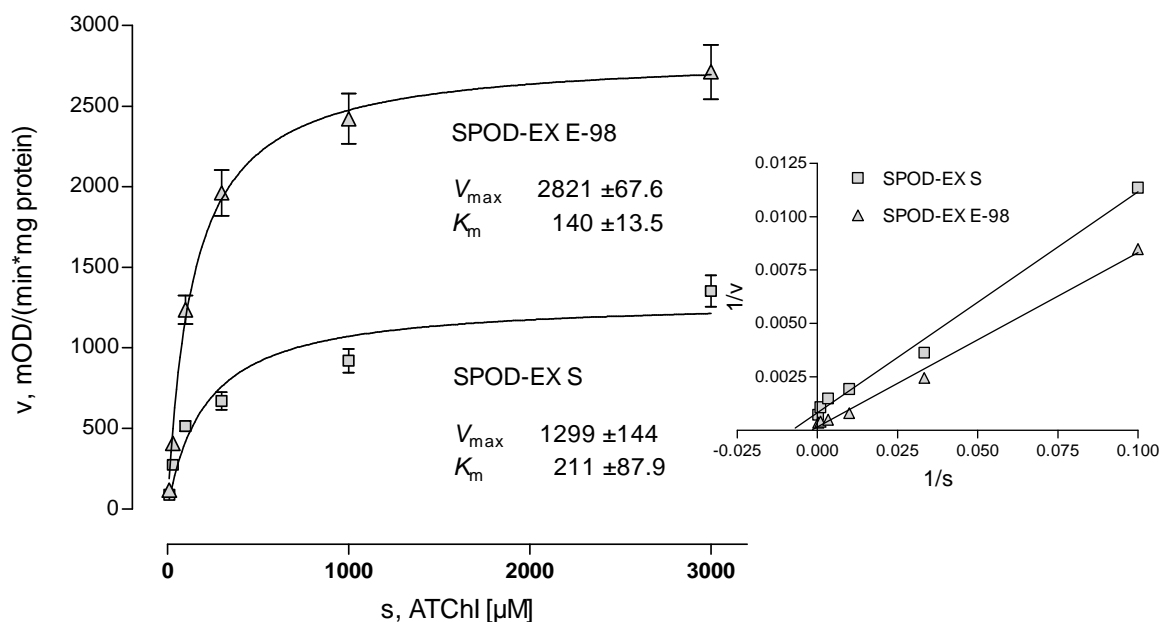

4.4.4.4 Acetylcholinesterase inhibition studies *in vitro*

Acetylcholinesterase activity of mass homogenates of the two *S. exigua* strains (SPOD-EX S and E-98) were inhibited by several insecticides (OPs and carbamates) and two non-insecticidal standard inhibitors (eserine and BW284c51) and expressed as IC_{50} -values (Table 18; see also Appendix D).

In the case of OPs, strain SPOD-EX E-98 showed a high insensitivity factor to methamidophos (IF=9.8) and a slight, but not significant IF to the second OP paraoxon-ethyl (IF=1.4).

Interestingly, the carbamate carbofuran showed stronger inhibition of the acetylcholinesterase in strain SPOD-EX E-98, indicating negative cross-resistance (IF=0.009). The results also showed that acetylcholinesterase from strain SPOD-EX E-98 was less sensitive to inhibition by the other carbamates, methomyl and thiodicarb, exhibiting IF-values of 9.2 and 4.6, respectively. A slight negative cross-resistance for SPOD-EX E-98 acetylcholinesterase was found also for BW284c51 (IF=0.7) and eserine (IF=0.011).

Table 18: IC₅₀-values of different inhibitors (10 min pre-incubation) for the inhibition of acetylcholinesterase in 2nd instar larvae of strains SPOD-EX S and SPOD-EX E-98 (+ Appendix D)

Compound / Chemical	Strain	IC₅₀ μM	CI 95%	IF*
Carbofuran	SPOD-EX S	54.0	44.7 to 64.4	0.009
	SPOD-EX E-98	0.475	0.415 to 0.543	
Methomyl	SPOD-EX S	9.0	7.3 to 11.2	9.2
	SPOD-EX E-98	82.3	55.2 to 122.6	
Thiodicarb	SPOD-EX S	14.4	8.9 to 23.3	4.6
	SPOD-EX E-98	66.3	63.9 to 68.8	
Methamidophos	SPOD-EX S	156.0	109 to 223	9.8
	SPOD-EX E-98	1534.0	893 to 2636	
Paraoxon-ethyl	SPOD-EX S	6.9	4.8 to 9.7	1.4
	SPOD-EX E-98	9.3	7.0 to 12.3	
Eserine	SPOD-EX S	23.4	11.0 to 49.5	0.011
	SPOD-EX E-98	0.245	0.203 to 0.295	
BW284c51	SPOD-EX S	0.028	0.024 to 0.034	0.7
	SPOD-EX E-98	0.019	0.017 to 0.021	

*IF = insensitivity factor, determined by dividing the IC₅₀ of strain E-98 by IC₅₀ of strain S

4.4.5 Partial purification of acetylcholinesterases

Acetylcholinesterase (AChE) from strains SPOD-EX S and SPOD-EX E-98 was purified using procainamide affinity chromatography. For AChE-purification 2nd instar larvae were used. Purification data obtained from each isolation step of strains SPOD-EX S and SPOD-EX E-98 are presented in Table 19.

The losses of activity during the individual purification steps were similar in both strains, except the elution profiles of the procainamide affinity purification step (Figure 38). AChE of strain SPOD-EX S was bound less to the matrix, and showed only a total activity of 2122 mOD/min compared with 24719 mOD/min for strain SPOD-EX E-98. This result suggested that the AChE of strain SPOD-EX E-98 shows a higher affinity to the procainamide affinity resin.

Finally, after three steps 2.4% and 13% of total AChE activity were obtained from strains SPOD-EX S and SPOD-EX E-98, respectively. For the following experiments, i.e. kinetic and inhibition studies, purified AChE samples with an activity of 993 ± 29 mOD/min/mg protein for strain SPOD-EX S and 8407 ± 35 mOD/min/mg protein for strain SPOD-EX E-98 were used.

Table 19: AChE purification scheme of *Spodoptera exigua* strains SPOD-EX S (660 mg) and SPOD-EX E-98 (330 mg)

Step	Remark	Strain	Volume [μl]	AChE activity total [mOD/min]	Yield [%]	mOD/min/mg protein
supernatant ^a	660 mg	S	2350	74088	100.0	
	330 mg	E-98	2350	119050	100.0	
PD10 column ^b	all fractions	S	7500	54420	73.5	
		E-98	7500	100095	84.1	
delivered on next step	- AChE measurement	S	7110	51590	69.6	
		E-98	7110	94890	79.7	
procainamide affinity column	homogenate	S	3010	15867	21.4	
		E-98	4140	17222	14.5	
	wash ^b	S	4250	270	0.4	
		E-98	5250	339	0.3	
	elution ^c	S	4500	2122	2.9	
		E-98	7000	24719	20.8	
delivered on next step from elution	- AChE measurement	S	4365	2058	2.8	
		E-98	6510	22989	19.3	
PD10 column ^b	all fractions	S	13000	2007	2.7	
		E-98	13000	21498	18.1	
for further experiments	fraction 8-16	S	4500	1790	2.4	993
	fraction 7-18	E-98	5500	15450	13.0	8407

^a 20mM sodium-phosphate buffer, pH 7.2, 1mM EDTA, 0.5% TX₁₀₀
^b 20mM sodium-phosphate buffer, pH 7.2, 1mM EDTA
^c 20mM sodium-phosphate buffer, pH 7.2, 1mM EDTA, 1mM NaCl

Figure 38: AChE elution profile from strains SPOD-EX S and SPOD-EX E-98 using a procainamide affinity column

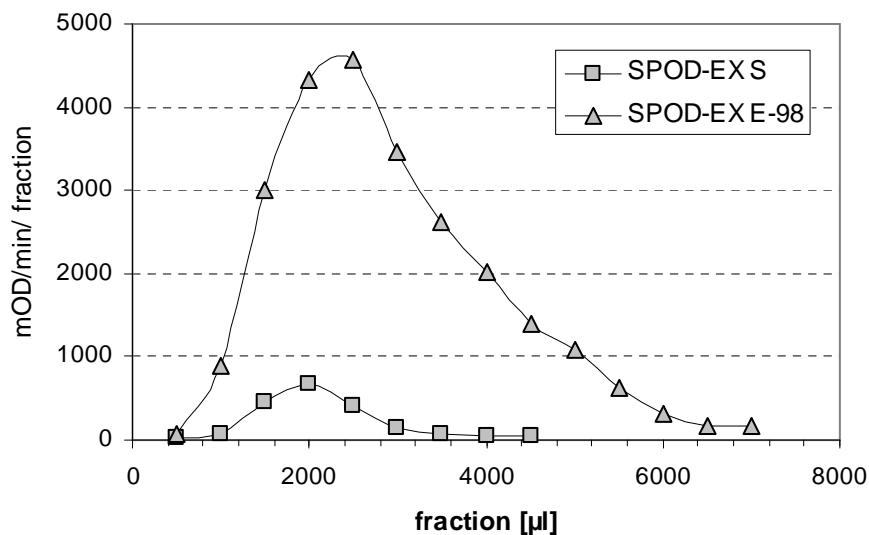

4.4.5.1 Michaelis-Menten kinetics

The enzyme activity (v) of purified AChE from strains SPOD-EX S and SPOD-EX E-98 towards ATChI was estimated in the presence of six different substrate concentrations (s). The Michaelis-Menten constant (K_m) and the apparent maximum rate of hydrolysis (V_{max}) obtained from Michaelis-Menten plots are presented in Figure 39.

The data in Figure 39 show that the V_{max} -value of the AChE in strain SPOD-EX E-98 (11015 ± 639 mOD/min/mg protein) was 10.7-fold higher than in strain SPOD-EX S (1031 ± 100 mOD/min/mg protein). In addition, the binding affinity to the substrate (K_m -value) in strain SPOD-EX E-98 ($76 \pm 20 \mu\text{M}$) was higher compared to strain SPOD-EX S ($117 \pm 47 \mu\text{M}$).

In mass homogenates (see section 4.4.4.3) and purified AChE similar results in K_m - and V_{max} -values between susceptible and resistant strain were observed. These results indicate a higher hydrolytic AChE enzyme activity in larvae of strain SPOD-EX E-98.

Figure 39: Michaelis-Menten and Lineweaver-Burk plots (right) of affinity purified AChE from strains SPOD-EX S and SPOD-EX E-98 using six concentrations of acetylthiocholine iodide (ATChI) as substrate (Data and equation of graphs are described in Appendix C)

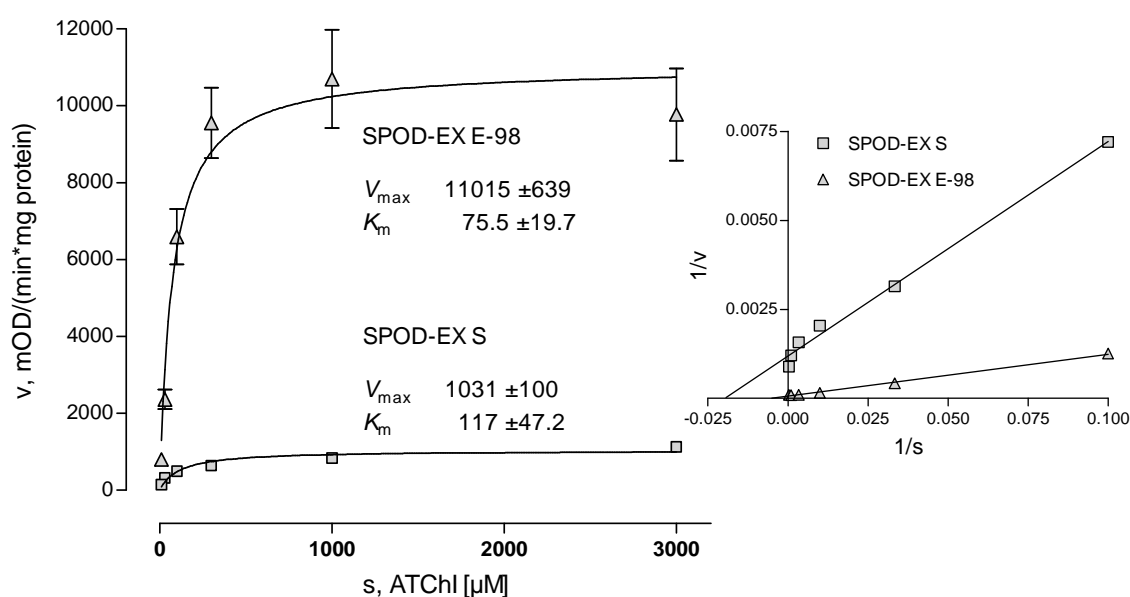

4.4.5.2 Inhibition studies with purified acetylcholinesterases

Three different compounds, i.e. carbofuran, methomyl and thiodicarb, were subjected to inhibition studies with purified AChE from strains SPOD-EX S and SPOD-EX E-98; inhibition parameters (IC_{50} -values) for AChE are listed in Table 20 (see also Appendix E).

Both methomyl and thiodicarb were less effective on AChE from strain SPOD-EX E-98 (Table 20) and resulting in insensitivity factors of AChE were 7.8 and 4.2, respectively. Similarly to the inhibition studies in crude homogenates carbofuran was found to be negatively cross-resistant in strain SPOD-EX E-98 (IF=0.009), i.e. AChE was 113-fold more susceptible to carbofuran compared with the enzyme purified from strain SPOD-EX S. In general, the inhibition studies using crude preparation and purified enzyme revealed similar inhibitory patterns (IC₅₀- and IF-values) for carbamates in both strains.

Table 20: Inhibition (IC₅₀-values) of purified AChE from strains SPOD-EX S and SPOD-EX E-98 by three insecticides (+ Appendix E)

Compound / Chemical	Strain	IC ₅₀ μM	CI 95%	IF*
Carbofuran	SPOD-EX S	43.1	33.6 to 55.3	
	SPOD-EX E-98	0.383	0.372 to 0.394	0.009
Methomyl	SPOD-EX S	7.0	4.8 to 10.2	
	SPOD-EX E-98	54.3	36.6 to 80.6	7.8
Thiodicarb	SPOD-EX S	9.4	7.5 to 11.7	
	SPOD-EX E-98	39.3	23.1 to 67.0	4.2

*IF = insensitivity factor, determined by dividing the IC₅₀ of strain E-98 by IC₅₀ of strain S

4.4.5.3 SDS-PAGE

SDS-PAGE profiles of affinity-purified AChE are shown in Figure 40. The purified AChE was 10-fold concentrated before subjecting to electrophoresis: 1.5 larva equivalents of a mass homogenate (2nd instar) were electrophoresed along the purified enzyme and stained using Coomassie Brilliant Blue R-250.

The procainamide affinity-purified enzyme of both strains (SPOD-EX S and E-98) appeared as a single band on SDS-PAGE in the expected molecular weight range for AChE, i.e. showing a molecular weight of approximately 62 kDa. No differences were seen in protein patterns between the two strains.

Figure 40: SDS-PAGE gel of affinity-purified AChE from *Spodoptera exigua* (strains SPOD-EX S and E-98). Lane 1+6: mass homogenate (1.5 larva equivalents); lane 2+5: SeeBlue® Pre-Stained Standard (10µl per well; molecular weights are given in kDa); lane 3+4: affinity purified AChE samples. The mobility of affinity-purified AChE from both strains of *S. exigua* corresponds to a molecular weight of ca. 62 kDa.

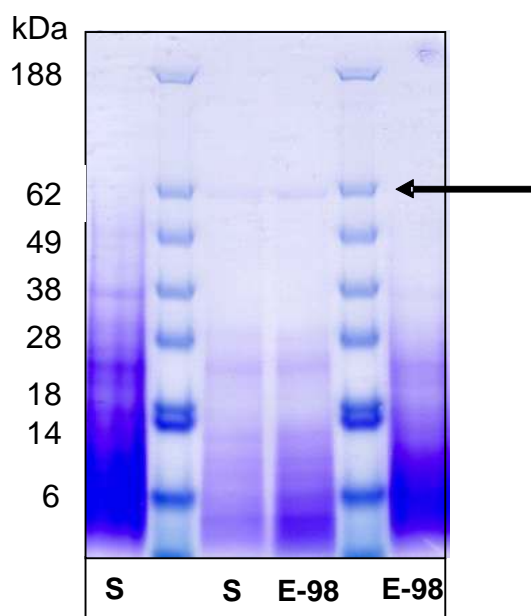

4.5 Molecular biology

4.5.1 Cloning and sequencing of sodium channel from *Spodoptera exigua*

The first PCR amplification using several degenerate primers (see Table 9) yielded different fragments spanning the region from domain II transmembrane segment 2 to linker between domain III-IV of the *para*-homologous sodium channel in *S. exigua* (strains SPOD-EX S and E-98). This sequence is covering almost the entire coding region of the gene, with a coding length of ~2.4kb.

Two expected fragments were amplified (Figure 41), first the primer pair 199f and 172r (anneal: 45°C) with an amplification product of 413bp containing the 5'end of the region. On the other hand primers 260f and 261r (anneal: 50°C) gave a fragment of the expected size of 1,305bp on the 3'end of the vgSCh.

Figure 41: Gel electrophoresis: PCR amplification of an 413bp (primers 199f + 172r) and an 1,305bp (primers 260f + 261r) product from strains SPOD-EX S and SPOD-EX E-98 of *Spodoptera exigua*

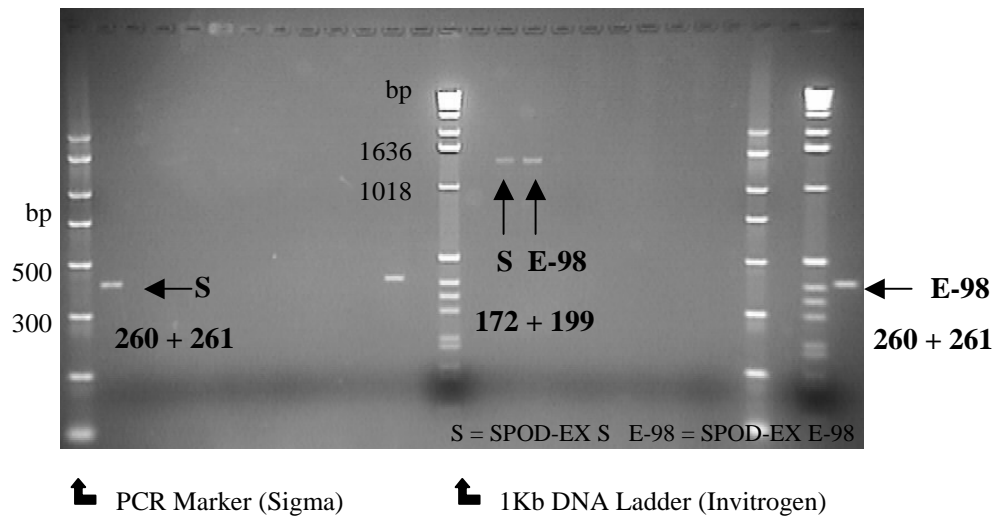

The second round of PCR using the outer primers 199f and 261r yielded a single band fragment (anneal: 50°C) of the expected size (~2.4kb) from both strains (electrophoresis gel is not shown). Subsequently, the extracted DNA fragments of both PCR reactions were cloned into pCR II-TOPO (Figure 42) vectors and transferred into chemical competent Top10 cells (Invitrogen).

Figure 42: The map shows the features of pCR II-TOPO vector and the sequence surrounding the TOPO cloning site and the restriction sites are additionally labelled (Picture was taken from www.invitrogen.com)

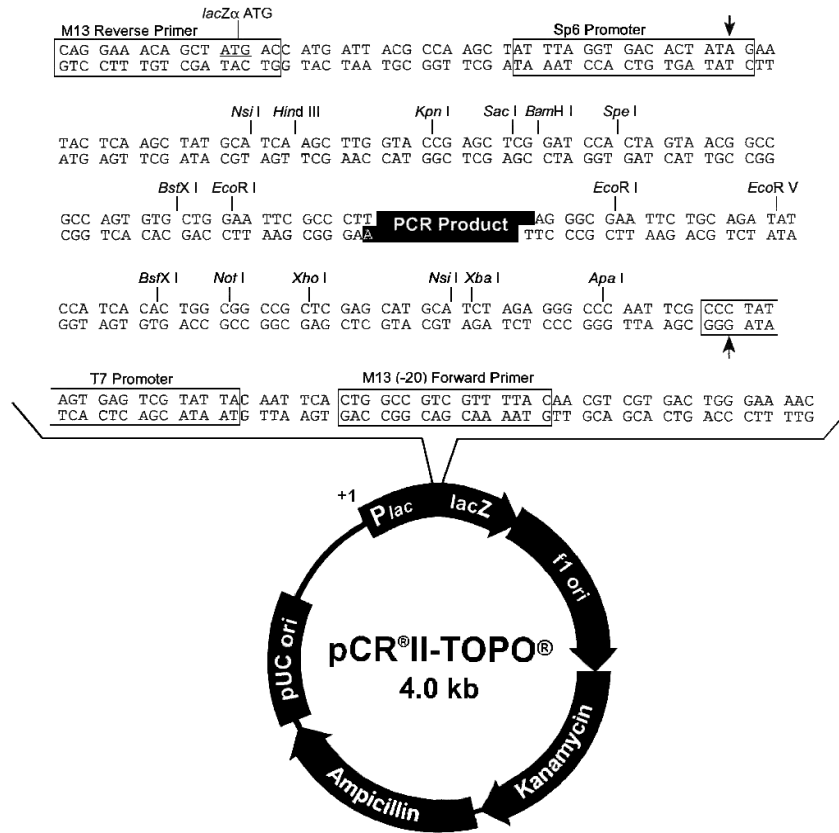

After transformation and culture, plasmids were purified using mini-prep and identified by digestion. The products of the first PCR derived from the sodium channel gene were digested with *EcoRI* to the expected fragments of 413 and 1,305bp (results not shown). Furthermore, *EcoRI* was found to restrict PCR products of the second reaction of ~2,400bp into two smaller fragments of 800 and 1,600bp, see Figure 43.

Figure 43: Digestion with *EcoRI*: Gel electrophoresis of restriction profiles for the amplified PCR products of the second PCR reaction using the primers 199f and 261r

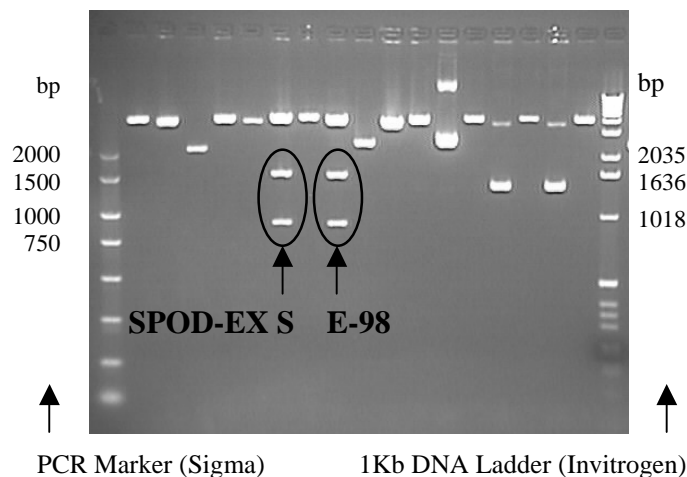

The inserts of two positive clones from each strain were then sequenced in both directions. The predicted DNA sequence of the searching region of the sodium channel showed a high level of similarity to the corresponding region of the *Drosophila melanogaster para* gene (Loughney *et al.*, 1989).

Sequencing of the sodium channel gene of *S. exigua* revealed only one mutation in the analyzed region. This was the substitution of leucine to phenylalanine (L1029F, *para* numbering EMBL: M32078) in the pyrethroid-resistant strain SPOD-EX E-98, resulting from a CTT to TTT single base change. This mutation is located in the transmembrane segment 6 of domain II (see Figure 19).

4.5.2 Pyrosequencing

After the detection through cloning and sequencing of only one *kdr*-point mutation (L1029F, according *para*-gene) in the vgSCh of *S. exigua*, the results were additionally checked in mass homogenates ($n=2$) and also in individual larvae ($n=8$) of both strains using the novel pyrosequencing technique.

This technique is a sequencing-by-synthesis method and allows the rapid real-time determination of 20-30 base pairs of a target sequence. In the case of detecting the *kdr*-mutation in the two strains SPOD-EX S and SPOD-EX E-98, specifically designed primers (Figure 44) were used and a sequential nucleotide addition (GATCATCGTGT) for the pyrosequencing reaction. As template genomic DNA from mass homogenates or single larvae was used, all larvae material was obtained from the 3rd instar.

Figure 44: Position of primers for pyrosequencing reaction

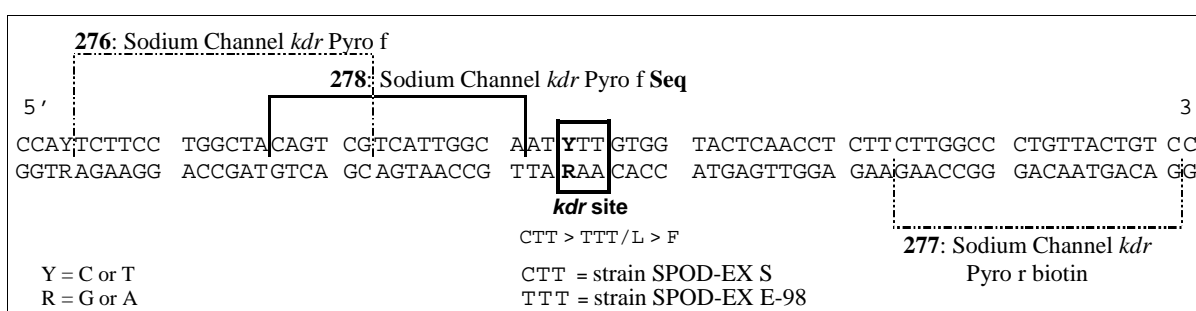

In Figure 45, strain SPOD-EX S shows the homozygous variant C (panel A) and the panel B corresponds to the homozygous variant T in strain SPOD-EX E-98, both based on mass homogenates.

The allelic variants could easily be separated by the clear difference in signal pattern. The homozygous variant C (strain SPOD-EX S) showed after the addition of dATP (normalization of the peak value) two single peaks, corresponding with the incorporation of T and C on the polymorphic position. Furthermore, a double signal was obtained when the nucleotide T was added to the reaction, i.e. resulting in a sequence of CTT (leucine). On the other hand, the homozygous variant T (strain SPOD-EX E-98) showed a 4-fold peak after the addition of A, and no signals for the following four nucleotides, corresponding with a sequence of TTT (phenylalanine).

The obtained pyrosequencing data for the mass homogenate samples (panel **A** and **B**) are exactly equal as the pyrograms of individual larvae of each strain, examples are shown in panels **C** (strain SPOD-EX S) and **D** (strain SPOD-EX E-98) in Figure 45.

Figure 45: Pyrograms: Single-nucleotide polymorphism analysis by pyrosequencing. The marked grey areas detected the sequence differences. Peak heights are proportional to the number of incorporated nucleotides.

A. + **B.** mass homogenate, **C.** + **D.** individual larvae.

SPOD-EX S (homozygote): Allele 1: AT CTT GTG...
 Allele 2: AT CTT GTG...
 SPOD-EX E-98 (homozygote): Allele 1: AT TTT GTG...
 Allele 2: AT TTT GTG...

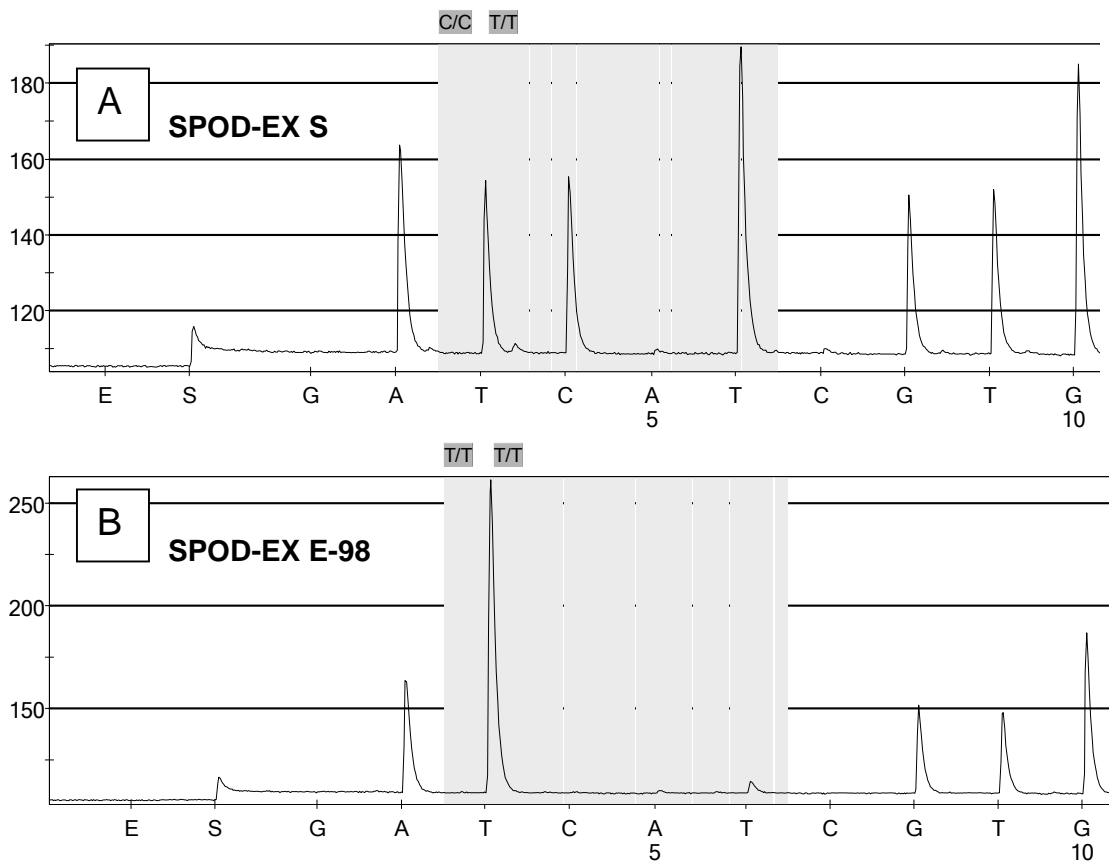

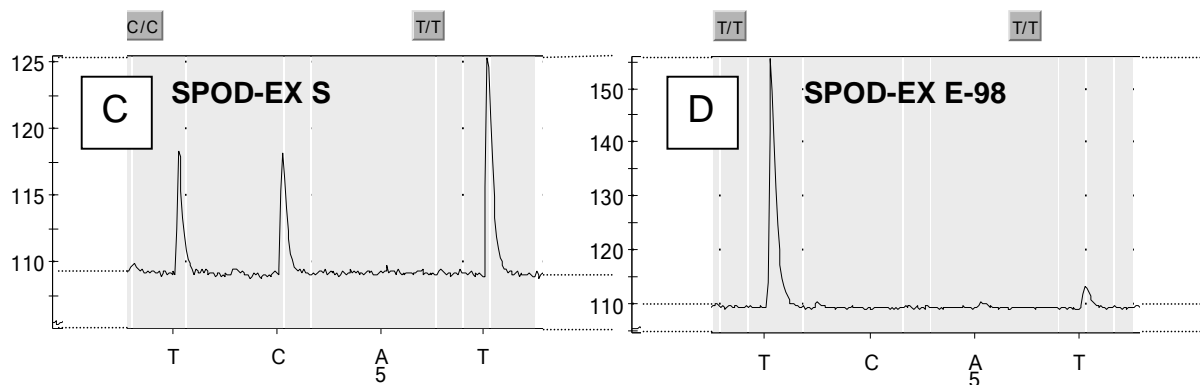

4.6 Pharmacokinetic studies in *Spodoptera exigua*

The focus of the following studies was to identify the critical pharmacokinetic differences between the susceptible (SPOD-EX S) and resistant strain (SPOD-EX E-98) of *S. exigua*, and to compare the pharmacokinetic profiles of three different insecticides. Therefore, the uptake and the excretion of topically applied radiolabelled compounds were measured in 5th instar larvae. Data for the pharmacokinetic studies of [¹⁴C]deltamethrin (strain SPOD-EX S vs. E-98), [¹⁴C]triflumuron (strain SPOD-EX S vs. E-98) and [¹⁴C]flubendiamide (strain SPOD-EX S) are present in Tables 21, 22, 23 and Figure 46. Generally, in the experiments with deltamethrin and triflumuron only small differences in the pharmacokinetic profiles between strains SPOD-EX S and SPOD-EX E-98 were measured.

Deltamethrin (Table 21): Deltamethrin penetrated rapidly through the cuticle in both strains followed by fast excretion of the compound equivalents. Immediately after application of deltamethrin solution, strain SPOD-EX S shows symptoms of poisoning in the first four hours, followed by a complete recovery after 4h. Affected larvae (strain SPOD-EX S) showed strong excitatory symptoms resulting in non-controlled movements explaining the lower values of the surface wash, and also the higher amount of radioactivity in the dishes compared with the resistant strain SPOD-EX E-98 (no symptomology of poisoning at applied doses). Four hours after application ca. 25% of the radiolabel was found in the larvae and 40% was excreted with the faeces. After 24h, only a small amount of [¹⁴C]deltamethrin could be detected in the larvae and ca. 90% of the radioactivity were found in the excreta. Both strains showed a rather rapid clearance of radiolabelled deltamethrin from the body.

Table 21: Penetration and distribution after topical application of [^{14}C]deltamethrin in 5th instar larvae of *Spodoptera exigua*

Time (h)	Strain	% Recovered [^{14}C]deltamethrin \pm SE ($n=3$)			
		Surface wash (external)	Larvae (internal)	Faeces (excretion)	Petri dishes
1	SPOD-EX S	28.0 \pm 3.4	34.2 \pm 3.0	24.1 \pm 3.0	13.7 \pm 0.9
	SPOD-EX E-98	50.9 \pm 2.5	28.8 \pm 1.4	12.2 \pm 1.7	8.2 \pm 2.1
2	SPOD-EX S	27.4 \pm 3.6	26.9 \pm 1.8	31.5 \pm 5.0	14.2 \pm 0.1
	SPOD-EX E-98	40.0 \pm 4.7	33.5 \pm 2.5	20.6 \pm 1.6	6.0 \pm 0.8
4	SPOD-EX S	14.3 \pm 1.5	31.9 \pm 3.5	41.6 \pm 3.3	12.2 \pm 0.7
	SPOD-EX E-98	22.7 \pm 5.3	24.3 \pm 1.0	47.5 \pm 4.2	5.5 \pm 1.4
8	SPOD-EX S	12.0 \pm 1.2	25.8 \pm 2.0	53.5 \pm 3.3	8.7 \pm 0.4
	SPOD-EX E-98	13.6 \pm 1.8	14.7 \pm 0.6	67.9 \pm 2.2	3.9 \pm 1.0
24	SPOD-EX S	3.0 \pm 0.6	7.5 \pm 0.6	83.1 \pm 0.9	6.4 \pm 0.3
	SPOD-EX E-98	0.9 \pm 0.4	4.8 \pm 1.0	92.0 \pm 1.3	2.3 \pm 0.3
48	SPOD-EX S	0.9 \pm 0.2	4.6 \pm 0.1	89.9 \pm 0.8	4.6 \pm 0.8
	SPOD-EX E-98	0.4 \pm 0.3	3.8 \pm 0.5	94.3 \pm 0.6	1.4 \pm 0.3

Total recovery: strain SPOD-EX S 83 \pm 0.4%; strain SPOD-EX E-98 84 \pm 0.4%

Triflumuron (Table 22): In the first hours ca. 10% of the applied [^{14}C]triflumuron was found in the larval body, and decreased to 5% after 48h. In comparison to deltamethrin, the elimination of triflumuron in *S. exigua* was more slowly.

After 24h, ca. 55% of the applied radiolabel was found in the faeces, and this increased to ca. 70% at the end of the experiment. In contrast, 90% of deltamethrin was observed at this time point in the faeces of the larvae. In addition, the amount of radioactivity stayed on the cuticle was ca. 20% (48h) after triflumuron application.

Table 22: Penetration and distribution after topical application of [¹⁴C]triflumuron in 5th instar larvae of *Spodoptera exigua*

Time (h)	Strain	% Recovered [¹⁴ C]triflumuron ± SE (n=3)			
		Surface wash (external)	Larvae (internal)	Faeces (excretion)	Petri dishes
1	SPOD-EX S	85.8 ± 2.6	7.8 ± 1.8	4.4 ± 0.4	2.1 ± 0.4
	SPOD-EX E-98	86.6 ± 1.6	5.4 ± 1.0	5.2 ± 0.8	2.8 ± 0.3
2	SPOD-EX S	79.7 ± 4.5	8.5 ± 1.7	8.9 ± 2.2	2.9 ± 0.8
	SPOD-EX E-98	69.4 ± 5.1	9.8 ± 3.2	16.9 ± 2.5	3.9 ± 0.9
4	SPOD-EX S	63.5 ± 0.6	11.0 ± 0.3	23.4 ± 0.1	2.2 ± 0.8
	SPOD-EX E-98	48.9 ± 2.3	8.1 ± 2.7	35.9 ± 1.5	7.2 ± 1.5
8	SPOD-EX S	54.3 ± 3.1	8.0 ± 0.4	34.4 ± 2.4	3.3 ± 1.0
	SPOD-EX E-98	55.5 ± 3.2	6.1 ± 1.6	33.3 ± 2.8	5.1 ± 0.7
24	SPOD-EX S	36.7 ± 3.2	7.4 ± 0.4	53.5 ± 2.9	2.3 ± 0.6
	SPOD-EX E-98	29.5 ± 2.1	5.0 ± 0.3	58.7 ± 1.7	5.8 ± 1.7
48	SPOD-EX S	14.7 ± 3.9	6.2 ± 0.6	77.7 ± 3.2	1.4 ± 0.3
	SPOD-EX E-98	24.1 ± 0.8	5.0 ± 0.4	69.2 ± 1.0	1.7 ± 0.1

Total recovery: strain SPOD-EX S 81 ± 0.8%; strain SPOD-EX E-98 82 ± 1.2%

Flubendiamide (Table 23 and Figure 46): The amount of unpenetrated [¹⁴C]flubendiamide recorded from the cuticle indicated a similar penetration profile as triflumuron, The levels of radiolabelled flubendiamide in the larvae increased slowly during time, and cumulated at a rate of 17% after 48h. The elimination of flubendiamde, ca. 60% after 48h, through faeces was not so fast compared with the two other compounds used in this study.

Table 23: Penetration and distribution after topical application of [¹⁴C]flubendiamide in 5th instar larvae of *Spodoptera exigua* strain SPOD-EX S

Time (h)	Strain	% Recovered [¹⁴ C]flubendiamide ± SE (n=4)			
		Surface wash (external)	Larvae (internal)	Faeces (excretion)	Petri dishes
1	SPOD-EX S	80.3 ± 1.6	6.0 ± 1.4	5.0 ± 1.0	8.7 ± 1.4
2	SPOD-EX S	73.3 ± 4.0	8.9 ± 1.6	11.9 ± 2.3	5.9 ± 1.3
4	SPOD-EX S	75.3 ± 1.8	7.9 ± 0.9	12.1 ± 2.6	4.7 ± 0.6
8	SPOD-EX S	52.3 ± 5.2	14.2 ± 1.4	28.3 ± 5.5	5.2 ± 1.1
24	SPOD-EX S	39.3 ± 5.9	17.3 ± 0.9	38.6 ± 5.2	4.8 ± 0.2
48	SPOD-EX S	22.9 ± 4.6	17.1 ± 1.2	57.0 ± 5.6	3.0 ± 0.3

Total recovery: strain SPOD-EX S 82 ± 0.6%

Figure 46: Pharmacokinetic profiles of [^{14}C]flubendiamide, topically applied to 5th instar larvae of *Spodoptera exigua* (strain SPOD-EX S):
A. Penetration and B. Retention and excretion

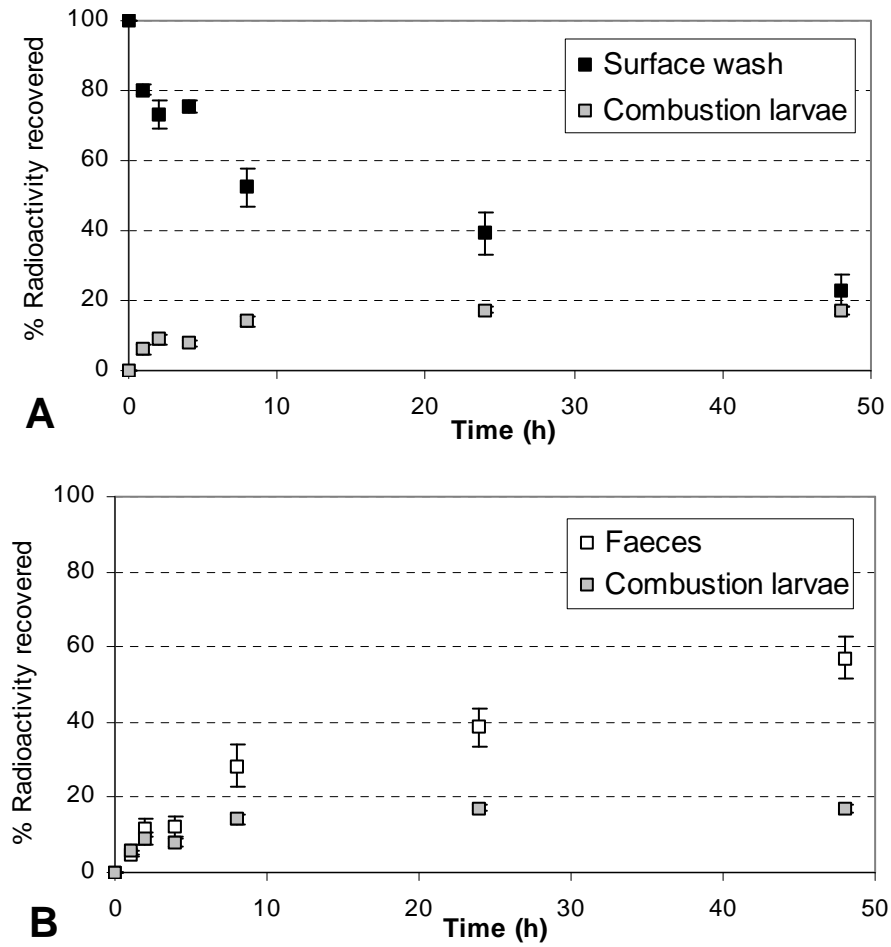

5 DISCUSSION

The discussion section of the present thesis is divided into two main parts. The first part deals with the investigation/discovery of the resistance mechanisms in a multi-resistant *Spodoptera exigua* strain on toxicological, biochemical, pharmacokinetic and molecular level. The second part presents and discusses the data of an extensive resistance risk assessment study for the novel insecticide flubendiamide in three noctuid pest species. The beet armyworm (*S. exigua*), the cotton bollworm (*Helicoverpa armigera*) and the tobacco budworm (*Heliothis virescens*) are of worldwide importance in several crops and are frequently exposed to high selection pressure by various insecticides applied for their control under field conditions. Consequently, insecticide resistance has developed in these insect species against several chemical classes of insecticides on the market.

5.1 Bioassays

Two different bioassay techniques, foliar spray and artificial diet were used to investigate the susceptibilities of three different laboratory strains, HELI-AR, HELI-VI and SPOD-EX S in detail. Twelve insecticides of different chemical groups were tested on 2nd instar larvae. The resulting EC-values of the dose-response curves obtained for the susceptible strains are used as a reference for future monitoring purposes.

The leaf-disc spray application bioassay is quite sophisticated due to the use of a purpose-build automatic spraying robot system. However, the advantage of the second bioassay type (artificial diet) is its cheapness and easiness and the prepared multi-well plates are stable for up to one month. This allows to sent ready-made “bioassay kits” in all regions worldwide for monitoring studies directly in the field.

Additionally, the resistance pattern of the *S. exigua* strain SPOD-EX E-98 was determined in comparison with strain SPOD-EX S. The two bioassays both work by oral uptake and contact mortality of insecticides. Generally, all three laboratory strains were equal or more susceptible to the insecticides in the spray application bioassay compared with the artificial diet bioassay. Resistance of strain SPOD-EX E-98 to several insecticides tested is discussed in detail below.

5.1.1 Endosulfan resistance

Both bioassay types conducted with 2nd instar larvae indicated significant differences in response to endosulfan between strains SPOD-EX E-98 and SPOD-EX S. However, the

endosulfan resistance levels were moderate but significant, and the resistance factors were 4.1 and >5.4 in the spray bioassay and in the artificial diet bioassay, respectively.

Cyclodiene insecticides, like endosulfan, act as GABA antagonists and so they suppress the inhibitory transmitter action of GABA, their action results in increased post-synaptic neuronal activity.

The frequent use of cyclodienes during the past decades has resulted in the development of resistance to this chemical class of insecticides, and especially to the major compound endosulfan (Gunning and Easton, 1994; Martin *et al.*, 1995; Murugesan and Dhingra, 1995; Armes *et al.*, 1996 and 1997; Kranthi *et al.*, 2002).

Resistance to cyclodienes, called *Rdl* resistance (resistance to dieldrin), usually results from a modification of the GABA-gated chloride channel. In most cases, molecular studies have identified a single point mutation (alanine to serine) associated with target-site insensitivity in this gene (Feyereisen, 1995; Soderlund, 1997; Bloomquist, 2001).

5.1.2 Indoxacarb resistance

The artificial diet bioassay using indoxacarb resulted in a moderate 3.7-fold lower susceptibility of strain SPOD-EX E-98 compared with the susceptible strain. In contrast in the other bioassay system (spray application) a higher resistance level (RF=21) to the oxadiazine, indoxacarb was observed.

Indoxacarb is a pro-insecticide which is converted to the toxic form by esterases through cleavage of the N-methoxycarbonyl group. The resulting NH-derivative is a highly potent voltage-dependent sodium channel (vgSCh) blocker especially in lepidopteran larvae (Wing *et al.*, 1998 and 2000).

Normally, one would expect indoxacarb to have a higher efficacy against strains showing higher esterase activities due to its more rapid and complete activation. However, such a response was not seen in strain SPOD-EX E-98. This could probably reflect a monooxygenase-based resistance conferred by the extremely high monooxygenase activity measured in the resistant strain SPOD-EX E-98.

For indoxacarb, a high level of resistance (705-fold) was only reported for the lepidopteran species, *Choristoneura rosaceana* (Ahmad *et al.* 2002).

Since the introduction of indoxacarb no cross-resistance to pyrethroids has been found on the molecular level, this is not surprising, because they act on different sites of the vgSCh (Wing *et al.*, 1998; Nauen and Bretschneider, 2002).

5.1.3 Carbamate and organophosphate resistance

Two important chemical groups on the insecticide market are organophosphates (OPs) and carbamates, both share the same mode of action, as acetylcholinesterase (AChE) inhibitors. AChE is responsible for the neutralisation of the neurotransmitter acetylcholine in the insect nervous system. In the moment, these compounds account for ca. 45% of the world market of all insecticides and acaricides marketed in crop protection.

However, there are many data on dramatic changes in insecticide susceptibility in important pest species, including *S. exigua* populations (Brewer *et al.*, 1990; Mascarenhas *et al.*, 1998; Aldosari *et al.*, 1996; Kerns *et al.*, 1998; Pérez *et al.*, 2000; Byrne and Toscano, 2001). This is the result of the intense and frequent use of OPs and carbamates in the field.

In the spray application bioassay, two OPs and one carbamate were tested on 2nd instar larvae of both *S. exigua* strains. The strain SPOD-EX E-98 turned out to be resistant to both OPs methamidophos and triazophos and resistance factors of 17.8 and 23.9 were calculated, respectively. In addition, only a moderate level of resistance was recorded for the carbamate thiodicarb (RF=6.4).

These results were confirmed in the artificial diet bioassay, where strain SPOD-EX E-98 exhibited resistance ratios of >5.5 and 28.7-fold against methamidophos and triazophos, respectively. Resistance to thiodicarb was >5.7-fold compared to strain SPOD-EX S. Additionally, a second carbamate, carbofuran, was tested and interestingly strain SPOD-EX E-98 was more sensitive to carbofuran (RF<0.3) than the susceptible strain SPOD-EX S, i.e. a negative cross-insensitivity was detected. Although the chemical structures of both compounds are related with each other, thiodicarb is essentially a dimer of two molecules of methomyl joined by an N-SN bridge.

The negative cross-insensitivity to carbofuran indicates that strain SPOD-EX E-98 has an altered AChE as resistance mechanism. This phenomenon was previously observed in several important pests (Raymond *et al.*, 1986; Brown and Bryson, 1992; Zhu and Clark, 1995; Yu *et al.*, 2003) using different carbamates, but also OPs.

5.1.4 Benzoylphenyl urea resistance

In both used bioassay methods larvae of strain SPOD-EX E-98 exhibited a strong resistance level against triflumuron, for the spray application a resistance factor of >84 was calculated. This result was confirmed by the artificial diet bioassay, expressing in a resistance factor greater than 46.3 for the resistant strain SPOD-EX E-98. Additionally, in the latter bioassay

method a further benzoylphenyl urea, hexaflumuron was tested and a resistance ratio of 23-fold was calculated.

These two benzoylphenyl ureas (BPUs) are acting on the chitin biosynthesis of insects, especially in lepidopteran larvae and so they are classified and well-known as insect growth regulators.

Resistance to benzoylphenyl ureas has been observed in several insect species, e.g. in recent reports as Ishaaya and Klein (1990), Sauphanor and Bouvier (1995), Van Laecke *et al.*, (1995) and Kristensen and Jespersen (2003). In the present work, both triflumuron and hexaflumuron were less active in SPOD-EX E-98. A result that is quite common in view of the positive cross-resistance usually observed between different BPUs, due to their structural similarity (Emam *et al.*, 1988; Van Laecke and Degheele, 1991a; Sauphanor and Bouvier, 1995; Van Laecke *et al.*, 1995). The higher toxicity of some BPUs is probably due to their high retention in the larval body and the cuticle, also observed in *Spodoptera* species (Emam *et al.*, 1988; Auda *et al.*, 1991; Van Laecke and Degheele, 1991a; Van Laecke *et al.*, 1995).

However, the fluorination in hexaflumuron could prevent proper attack by monooxygenases as it is known that fluorine atoms protect from detoxification. In the case of SPOD-EX E-98 both triflumuron and hexaflumuron are most probably affected by a similar resistance mechanism, which could be either detoxification through metabolic enzymes (monooxygenases) or target-site resistance.

In several cases, mechanisms of BPU resistance seem to be caused by all three groups of metabolic enzymes, through hydrolytic (esterases) and oxidative (monooxygenases) processes as well as conjugation supported by GSTs (Ishaaya and Klein, 1990; Van Laecke and Degheele, 1991a and 1991b). Especially, hydrolysis of the urea bridge and conjugation of BPUs seem to be the major detoxification route of BPUs in *S. exigua* (Van Laecke and Degheele, 1991a and 1991b).

In this study, the resistance to triflumuron in strain SPOD-EX E-98 was not affected by the action of all synergists tested, i.e. PBO, DEF and profenofos. PBO is a monooxygenase inhibitor and DEF and profenofos inhibit esterases. A possible metabolism through the action of GSTs is less likely, because no significant differences were observed in the biochemical assay between both *S. exigua* strains.

Consequently, such a strong resistance factor without any effects of synergists on toxicity suggests a decreased binding at the target-site, which remains elusive since the introduction of

BPU. Further studies on the molecular level are necessary to characterise such proposed target-site insensitivity to BPUs in this highly resistant *S. exigua* strain SPOD-EX E-98.

5.1.5 Pyrethroid resistance

Both bioassays revealed extremely high resistance levels in strain SPOD-EX E-98 against the pyrethroid deltamethrin. Resistance ratios of 1063-fold (spray application) and 708-fold (artificial diet) were calculated. A second pyrethroid, etofenprox, reached a lower resistance factor of 45 in the artificial diet bioassay.

During the past decades, the extensive and widespread use of pyrethroids to control *Spodoptera* species led to the development of resistance in many agronomic cropping systems (Riskallah, 1983; Brewer and Trumble, 1989; Brewer *et al.*, 1990; Ishaaya and Klein, 1990; Yu *et al.*, 1991 and 1992; Aldosari *et al.*, 1996; Kranthi *et al.*, 2002), this also includes the pyrethroid deltamethrin (Delorme *et al.*, 1988; Van Laecke *et al.*, 1995; Pérez *et al.*, 2000). Studies on the metabolic mechanisms for pyrethroid detoxification in insects revealed two predominant detoxification pathways: oxidation by monooxygenases and/or hydrolysis by esterases (Elliott *et al.*, 1978; Ishaaya, 1993; McCaffery, 1999).

In vivo suppression of resistance by application of inhibitors of metabolic enzymes is often used as a diagnostic tool, likewise in this study. In this study a topical application bioassay on 5th instar larvae of *S. exigua* was used and confirmed the high resistance level in strain SPOD-EX E-98 towards deltamethrin, resulting in a resistance factor of 590. The pre-treatment of three different synergists, PBO, DEF and profenofos, revealed no significant synergistic effects with the esterase inhibitors DEF and profenofos.

Interestingly, the use of PBO, a monooxygenase inhibitor, resulted in a reduction of the ED₅₀ from 11,202ng to 373ng in strain SPOD-EX E-98. This synergistic factor of 30 for PBO strongly suggests the presence of cytochrome P₄₅₀-mediated degradation of deltamethrin in the resistant strain.

In the recent literature several cases were reported where the use of PBO resulted in a partial or complete loss of pyrethroid resistance, e.g. in a permethrin-resistant *S. exigua* strain PBO reduced the resistance ratio significantly from 92.5- to 7.9-fold (Natsuhara *et al.*, 2004) or resulting in a complete loss of the cypermethrin resistance in *Spodoptera litura* larvae Armes *et al.* (1997).

The synergist study suggests that monooxygenases are not only responsible for pyrethroid resistance in this resistant *S. exigua* strain SPOD-EX E-98, because PBO did not completely

suppress the deltamethrin resistance. In the case of strain SPOD-EX E-98 an additional non-metabolic resistance mechanism must be involved, i.e. target-site resistance (*kdr*).

5.2 Molecular aspects of pyrethroid resistance

In the present study, the nucleotide coding sequence (~2.4kb) of part of the voltage-gated sodium channel gene from the insecticide-susceptible strain SPOD-EX S and the pyrethroid-resistant strain SPOD-EX E-98 was detected. This gene is known to be implicated as the site of knockdown resistance (*kdr*), an important resistance mechanism in insects that confers nerve insensitivity to DDT and pyrethroid insecticides.

As outlined in Figure 47, the sequencing of the sodium channel gene of *S. exigua* (*para*-homologous) revealed only one mutation CTT to TTT, encoding a leucine to phenylalanine change (L1029F, *para* numbering) in strain SPOD-EX E-98. As expected, all the resistant alleles of individual larvae of strain SPOD-EX E-98 carry the same single-nucleotide substitution in homozygous variant T, determined through the novel pyrosequencing technique. Pyrosequencing is a recently developed technique for the detection of the allelic variants of a SNP, possibly leading to insecticide resistance.

Figure 47: Partial cDNA sequence of the transmembrane segment 6 in the domain II (IIS6) of the sodium channel from *Spodoptera exigua* (strains SPOD-EX S and E-98). Further, an alignment of the predicted amino acid sequences of both strains are compared with sequences of *Heliothis virescens*, *Musca domestica* (*hscp*) and *Drosophila melanogaster* (*para*). The box indicates the position of polymorphisms (amino acid substitutions) associated with insecticide resistance to pyrethroids. Numbering follows *D. melanogaster para* translation.

----- domain IIS6 -----	
DNA sequence	
SPOD-EX S	G C T A C A G T C G T C A T T G G C A A T C T T G T G G T A
SPOD-EX E-98	G C T A C A G T C G T C A T C G G C A A T T T T G T G G T A
Amino acid sequence	
SPOD-EX S	A T V V I G N L V V
SPOD-EX E-98	A T V V I G N F V V
<i>H. virescens hscp</i>	A T V V I G N L/H V V
<i>M. domestica</i>	A T V V I G N L/F V V
<i>D. melanogaster para</i>	A T V V I G N L V V
	1031*
----- end of IIS6 -----	
DNA sequence	
SPOD-EX S	C T C A A C C T C T T C T T G G C C C T G T T A C T G T C C
SPOD-EX E-98	C T C A A C C T C T T C T T G G C C C T G T T A C T G T C C
Amino acid sequence	
SPOD-EX S	L N L F L A L L L S
SPOD-EX E-98	L N L F L A L L L S
<i>H. virescens hscp</i>	L N L F L A L L L S
<i>M. domestica</i>	L N L F L A L L L S
<i>D. melanogaster para</i>	L N L F L A L L L S
	1041*

*numbering is in relation to the *D. melanogaster para* gene.

H. virescens hscp: Park *et al.* (1999); EMBL: AF072493

M. domestica: Williamson *et al.* (1996); EMBL: X96668

D. melanogaster para: Loughney *et al.* (1989); EMBL: M32078

An amino acid sequence comparison of this region between the two *S. exigua* strains (SPOD-EX S and E-98), *H. virescens* and *M. domestica* in relation to the *para* sodium channel gene from *D. melanogaster* is shown in Figure 47. This mutation occurs at a position homologous to the mutation L to F (L1014F) in *M. domestica* (Williamson *et al.*, 1996) and an L to H change in *H. virescens* (L1029H, Park *et al.*, 1999) both reported to be associated with knockdown resistance (*kdr*) to pyrethroids.

In addition, the L to F change in IIS6 has been associated with *kdr* phenotypes in several insect species, e.g. *Blattella germanica* (Dong, 1997), *Leptinotarsa decemlineata* (Lee *et al.*,

1999), *Haematobia irritans* (Guerrero *et al.*, 1997), *Plutella xylostella* and *Myzus persicae* (Martinez-Torres *et al.*, 1997) as the most common mutation. At the same position, an L to S mutation was observed in *Anopheles gambiae* (Ranson *et al.*, 2000) and *Culex pipiens* (Martinez-Torres *et al.*, 1999). The region (IIS6) is highly conserved across a range of insect species, for example in Martinez-Torres *et al.* (1997) three lepidopteran species share 99% identity in the amino acid sequence. According to the predicted sodium channel structure, the location of this mutation within the intracellular mouth of the channel pore in a region, known to be important for channel inactivation, provides additional evidence that this mutation is indeed involved in nerve insensitivity resistance (*kdr*).

However, extensive sequencing between segment 2 of domain II and the linker between domain III and IV, only a single-nucleotide polymorphism was identified in the region segment 6 from domain II (IIS6). Most of the mutations known to be associated with *kdr* or *super-kdr*-types are detected in this region (Vais *et al.*, 2001; Dong, 2003).

Several studies have identified additional sodium channel mutations, which co-exist with the L to F (IIS6) mutation in pyrethroid-resistant strains (Vais *et al.*, 2001; Dong, 2003). These *super-kdr* phenotypes express higher resistance levels (>100-fold) compared with moderate levels of *kdr*-types (<100-fold). For example, in a *super-kdr* strain of the diamondback moth (*P. xylostella*), which exhibit great levels of resistance (>100-fold) to Type II pyrethroids, a second mutation T929I was found in addition to the common L to F mutation (Schuler *et al.*, 1998).

In the bioassay part of this study the strain SPOD-EX E-98 exhibited resistance factors of >700 for the pyrethroid deltamethrin. These bioassay data are not consistent to the observation of just one *kdr* mutation.

Finally, the first reason for the high pyrethroid resistance observed in this study is a *kdr* mutation (L1029F) in the target-site, the vgSCh. Furthermore, the biochemical investigations and the synergistic study suggested that a metabolic detoxification through monooxygenases must also be present in strain SPOD-EX E-98.

5.3 Pharmacokinetic studies

The two major mechanisms of resistance are metabolic detoxification and altered target-sites of the insecticide target protein. Another factor contributing to resistance is the change of the pharmacokinetic behaviour, e.g. slower penetration of the toxicant through the cuticle. Such a reduced-penetration mechanism is often combined with the two major mechanisms mentioned

above, and has a supplementary effect on the resistance level of the resistant insect (Oppenoorth, 1985).

In addition to the synergist study, the cuticular penetration, internal recovery and excretion, via faeces of [¹⁴C]-labelled insecticides (deltamethrin, flubendiamide and triflumuron), were investigated after topical application on the 5th instar larvae of both *S. exigua* strains (for flubendiamide only strain SPOD-EX S was used).

These investigations revealed no significant differences in the pharmacokinetic profiles of the susceptible and the resistant strain when radiolabelled deltamethrin and triflumuron were applied. Based on these results it can be concluded that this resistance mechanism (reduced penetration) has no importance for deltamethrin and triflumuron resistance in strain SPOD-EX E-98.

Nevertheless, lower penetration and/or faster excretion of different insecticides have been shown to contribute to resistance in several lepidopteran species, e.g. in *H. armigera* (Gunning *et al.*, 1991; Ahmad and McCaffery, 1999); *H. virescens* (Little *et al.*, 1989; Abd-Elghafar *et al.*, 1994; Ottea *et al.*, 1995); *Helicoverpa zea* (Abd-Elghafar and Knowles, 1996); *P. xylostella* (Noppun *et al.*, 1989); *Spodoptera littoralis* (Emam *et al.*, 1988; Lagadic *et al.*, 1993), and also in *S. exigua* (Delorme *et al.*, 1988; Smagghe *et al.*, 2003).

The comparison of the pharmacokinetic behaviour of insecticides used revealed that flubendiamide and triflumuron expressed a similar pharmacokinetic profile as a function of time. Whereas, deltamethrin is characterised through a fast penetration of the cuticle (after 4h only 20% remained on the cuticle), this property contributes to the fast acting “knock-down” symptoms of pyrethroids. On the other hand, at this time nearly half of the applied [¹⁴C]deltamethrin was excreted via faeces. The 50% level of excretion for triflumuron and flubendiamide was reached only after 24 and 48h, respectively. Generally, triflumuron and flubendiamide demonstrated a slower cuticular penetration into the larval body and a slower elimination through faeces.

Finally, knowledge of the pharmacokinetics, using radiolabelled compounds, is an essential tool in understanding one possible mechanism of resistance to a given insecticide.

5.4 Biochemical studies of insecticide detoxification enzymes

5.4.1 Glutathione S-transferases

Insect glutathione S-transferases (GSTs) are known to be involved in the development of resistance to insecticides. The significance of GSTs in insecticide detoxification was first reported in OP-resistant houseflies (Motoyama and Dauterman, 1975).

With respect to the more recent literature, the correlation of insecticide resistance with higher GST activity has been reported from several other insects (Grant and Hammock, 1992; Ranson *et al.*, 1997; Yu and Hang, 2000; Rauch and Nauen, 2003), including lepidopteran species (Huang *et al.*, 1998; Yu, 2002). Changes in the transacting regulation of one or more GSTs appear to be responsible for insecticide resistance; the molecular background is best characterized in *M. domestica* and the mosquitoes *An. gambiae* and *Aedes aegypti* (Feyereisen, 1995; Grant and Hammock, 1992; Ranson *et al.*, 1997; Hemingway, 2000). One rare example of molecular-based over-expression of GST and direct relationship to OP resistance in insects was described from the lepidopteran diamondback moth, *P. xylostella* (Huang *et al.*, 1998).

In this study, levels of GST activity were assessed in mass homogenates and single larvae of *S. exigua* with CDNB, a well established artificial substrate for GST activity measurements (Habig *et al.*, 1974). GST activity in individual larvae of strain SPOD-EX S was compared with the resistant strain SPOD-EX E-98 and only subtle differences in frequency distributions were apparent. The measurement in mass homogenates expressed also no significant differences between both strains.

In addition to CDNB, the GST activity was fluorometrically measured with MCB, a recently introduced artificial substrate (Nauen and Stumpf, 2002). This biochemical assay also revealed no significant differences in GST activity between the strain SPOD-EX S and the resistant strain SPOD-EX E-98.

In some cases greater differences in GST activities between individual strains were detected with MCB rather than CDNB, for example in *Tetranychus urticae* (Nauen and Stumpf, 2002; Stumpf and Nauen, 2002) or in *Bemisia tabaci* (Rauch and Nauen, 2004).

In conclusion, the activity measurements with both artificial substrates, CDNB and MCB, suggest that GST did not play an important role in insecticide resistance in strain SPOD-EX E-98.

5.4.2 Carboxylesterases

Carboxylesterases (CE) play an important role in the biotransformation of different insecticides; they hydrolyse and subsequently detoxify several insecticides. Esterase-based resistance to organophosphates, carbamate and pyrethroids is common in a range of different insect pests; all substrates/insecticides detoxified via this route contain an ester moiety. Several studies reported higher esterase activity in resistant insect populations (Yu, 1992; Kanga *et al.*, 1997; Kranthi *et al.*, 2001; Rossiter *et al.*, 2001; Wu *et al.*, 2004; Yang *et al.*, 2004).

In the majority of resistant pest insects, higher esterase activity is elevated through over-expression (Feyereisen 1995; Soderlund, 1997; Hemingway, 2000). However, esterase gene(s) amplification is only well characterised on the molecular level in resistant strains of *Culex* mosquitoes (Moches *et al.*, 1986; Karunaratne *et al.*, 1998), *M. persicae* (Field *et al.*, 1988; Field and Devonshire, 1998) and *Nilaparvata lugens* (Small and Hemingway, 2000b).

In *S. exigua* (2nd instar larvae) investigated here, significant differences in the CE activity between strain SPOD-EX S (60 ± 7 nmol/min/mg protein) and the resistant strain (160 ± 7 nmol/min/mg protein) could be detected, resulting in a 2.7-fold higher enzyme activity in strain SPOD-EX E-98.

In later instars of some noctuid species similar CE activities were found (Yu, 1992; Ibrahim and Ottea, 1995; Zhao *et al.*, 1996; Yu *et al.*, 2003; Yang *et al.*, 2004), ranging between 100 and 700 nmol/min/mg protein.

Additionally, the CE activity was also measured in single larvae ($n=50$) in order to determine the frequency distribution pattern in both strains. Strain SPOD-EX E-98 showed a more heterogeneous Gauss curve compared with the frequency distribution of strain SPOD-EX S.

The carboxylesterase activity in mass homogenates and in single larvae was investigated by using a standard biochemical assay. Additionally, a native polyacrylamide gel electrophoresis (nPAGE) was used to demonstrate quantitative and qualitative inter-strain differences in esterase banding patterns between the two strains (SPOD-EX S and E-98). Several esterases of different mobility were found in both strains, but the resistant strain SPOD-EX E-98 shows two additional bands not detected in strain SPOD-EX S.

The observed esterase bands in both strains are not acetylcholinesterases. Two inhibitors, BW284c51 and eserine were used and no inhibitory effect was seen, both compounds are known as excellent acetylcholinesterase standard inhibitors.

Generally, other electrophoretic studies for example in *H. armigera* (Gunning *et al.*, 1996b and 1999) also described similar esterase bands patterns. However, for *S. exigua* no

comparable study is found in the literature. Gunning *et al.* (1996b) found a correlation between additional esterase bands (low mobilities, R_m 0.24-0.33) and resistance to pyrethroids in *H. armigera*. Furthermore, strains with low-level fenvalerate resistance (5- to 30-fold) showed only one additional band at R_m 0.33, and this relationship was also described in nPAGE studies of Gunning *et al.* (1999) and Young *et al.* (2005). These results with regard to the additionally found bands in *S. exigua*, suggest that quantitative and qualitative changes (over-expression of iso-enzymes) of esterases are involved in the hydrolysis of pyrethroids and possibly other insecticides.

The *in vitro* inhibition experiments of this study showed that the pyrethroids, deltamethrin and etofenprox, have no effect on the esterases banding patterns in both *S. exigua* strains. This result most likely suggests that the pyrethroid resistance in strain SPOD-EX E-98 is not esterases mediated.

Furthermore, nPAGE showed that the synergist and OP profenofos is an excellent inhibitor of all esterase bands in both strains, and the second organophosphate triazophos inhibited completely the fast moving esterases (lower part of the gel); both compounds also inhibited the thick additional band in the resistant strain SPOD-EX E-98. The two carbamates, carbofuran and thiodicarb, expressed a similar result as triazophos, a slight inhibition of the lower part of the gels.

In *in vivo* inhibition experiments (pre-treatment of larvae) with *H. armigera* (Gunning *et al.*, 1999) it was shown that, OPs, including profenofos, inhibited esterases which have been linked to pyrethroid resistance.

On the other hand, the general esterase inhibitor DEF inhibited nearly all esterases on the gel, except the additional dark band in the resistant strain SPOD-EX E-98. In biochemical inhibition studies, DEF has the same inhibitory potential in both strains. The analysis of the inter-strain differences of the esterase patterns on nPAGE detected differences in the response to DEF.

The insecticide synergist PBO is known as a specific inhibitor of microsomal monooxygenases, but recent studies reported that PBO additionally inhibits resistance-associated esterases (Young *et al.*, 2005). In this study, PBO displays no inhibitory effects on the esterase bands in *S. exigua*.

5.4.3 Cytochrome P₄₅₀-dependent monooxygenases

Cytochrome P₄₅₀-dependent monooxygenases (monooxygenases) catalyze a variety of oxidative reactions, using a broad-spectrum of exogenous and endogenous substrates

(Hodgson, 1983; Feyereisen, 1999). Therefore, many cases of metabolic resistance in insects to insecticides are the result of enhanced monooxygenase activities. Several authors (Feyereisen, 1995 and 1999; Bergé, 1999; Scott, 1999; Siegfried and Scharf, 2001) have reviewed the role of monooxygenases as one of the major metabolic mechanisms for resistance to many classes of insecticides.

The involvement of monooxygenase enzymes in resistance can be shown by several methods. The first indication that this group of metabolic enzymes must be involved in the resistance to insecticides was the observation that the monooxygenase inhibitor sesamex could result in the loss of resistance to carbaryl (Eldefrawi *et al.*, 1960).

Monooxygenase inhibitors, especially PBO, are commonly used, not only for the demonstration of oxidative metabolism in resistant populations, but also in the control of resistant populations in the field (Hodgson, 1983; Scott, 1999).

The monooxygenase-mediated resistance is often first detected through bioassays using additionally sublethal doses of monooxygenase inhibitors, such as PBO. The co-application of the synergist usually increases the toxicity of an insecticide in resistant strains. Additionally, biochemical and genetic diagnostic tools were used for the exact characterisation of the resistance at the molecular level.

High monooxygenase activity associated with insecticide resistance has regularly been observed in microsomal pellets prepared from larval midguts of noctuid species (Yu, 1991 and 1992; Rose *et al.*, 1995; Van Laecke *et al.*, 1995; Qiu *et al.*, 2003; Smagghe *et al.*, 2003; Yu *et al.*, 2003; Yang *et al.*, 2004). This is not surprising, as the gut tissue is known as a primary source of digestive enzymes needed for food conversion into nutrients, but also the detoxification of xenobiotics such as insecticides (Smagghe and Tirry, 2001).

For this study, a sensitive biochemical method was employed for the detection of monooxygenase activity in 5th and especially in 2nd instar larvae of *S. exigua*, in order to compare the results with the bioassay data and the other biochemical investigations (GST, AChE and CE).

For the biochemical detection of monooxygenase activities a highly sensitive and fluorometric microplate assay according Stumpf and Nauen (2001) was used. The monooxygenase activity can be measured quantitatively with the artificial substrate 7-ethoxycoumarin which is O-deethylated by monooxygenases to the highly fluorescent product 7-hydroxycoumarin.

This model substrate was already used to detect microsomal monooxygenase activity in several insect species, for example, *Bemisia tabaci* (Rauch and Nauen, 2003), *Cydia pomonella* (Sauphanor, 1997; Bouvier, *et al.*, 2002), *H. armigera* (Yang *et al.*, 2004) or

in single *D. melanogaster* abdomens (DeSousa *et al.*, 1995). For *T. urticae*, Stumpf and Nauen (2001) described the use of a 10,000g supernatant instead of microsomes as enzyme source for the measuring of the 7-ethoxycoumarin O-deethylation (ECOD) activity.

Furthermore, the elevated activity of ECOD in insect species has been associated with resistance to different classes of insecticides, e.g. pyrethroids (DeSousa *et al.*, 1995; Sauphanor *et al.*, 1997; Yang *et al.*, 2004), neonicotinoids (Rauch and Nauen, 2003) or in acaricide resistance to METIs (Stumpf and Nauen, 2001) and abamectin (Stumpf and Nauen, 2002) in spider mites.

Using the guts of 5th instar larvae, the resulting microsomal ECOD activity in strain SPOD-EX E-98 (1076 ± 55 pmol/30 min/mg protein) was 5.9-fold higher than in the susceptible strain SPOD-EX S (184 ± 28 pmol/30 min/mg protein). In case of *H. armigera*, the microsomal monooxygenase activity against ECOD was 3- to 27-fold higher in resistant field strains. Finally, the higher monooxygenase activity was responsible for the pyrethroid resistance in these strains (Yang *et al.*, 2004).

The determination of microsomal monooxygenase activity using isolated guts from 2nd instar larvae of *S. exigua* is very difficult, because a lot of biological material is necessary and a dissection of gut from such small larvae (length: ca. 3mm) is impossible. Therefore, the whole larva was used as enzyme source, but the head was removed, because parts of the head capsule were shown to be self-fluorescence at 390nm, the detection wavelength of 7-hydroxycoumarin. Due to their small size, it was not possible to measure ECOD activity in individual larvae, and at least 5 larva equivalents per microtiter plate well are needed. The susceptible strain SPOD-EX S showed an ECOD activity of 197 ± 37 pmol/30 min/mg protein and the resistant strain SPOD-EX E-98 an activity of 1620 ± 284 pmol/30 min/mg protein; this was an 8.2-fold difference between the strains.

The ECOD activity was additionally inhibited *in vitro* by 1mM PBO, a monooxygenase inhibitor which is generally used as a synergist to suppress insecticide resistance and to study resistance mechanisms in bioassays. The resistant strain SPOD-EX E-98 showed a 1.5-fold increase in comparison to the susceptible strain.

This assay is suitable to detect increasing monooxygenase (ECOD) activity in small insects without the necessity to isolate microsomes, and it seems to be a strong monitoring tool for future programs.

Generally, 2nd instar larvae expressed in both strains higher ECOD activities compared with 5th instar larvae. A possible explanation is that the 5th instar larvae were sampled directly after moulting and the 2nd instar during feeding. In literature, it was described that phytophagous

larvae showing higher monooxygenase expression in the midgut during periods of active feeding (Snyder *et al.*, 1995; Ranasinghe *et al.*, 1997), such as the 2nd instar larvae in this study.

In conclusion, these results suggest that the difference in the capacity for the metabolic degradation via O-deethylation between strains SPOD-EX S and SPOD-EX E-98 is a possible mechanism responsible for insecticide resistance in the multi-resistant strain SPOD-EX E-98.

5.4.4 Acetylcholinesterases

Acetylcholinesterase (AChE), responsible for the cleavage of the neurotransmitter acetylcholine, is the target-site for OP and carbamate insecticides. The properties of insect AChEs are important for understanding AChE insensitivity as an insecticide resistance mechanism.

Therefore, qualitative and quantitative differences between the forms of AChE in the two *S. exigua* strains were analysed using various biochemical assays. The extensive use of OPs and carbamates to control insect pests has led to “resistant” enzymes, less inhibited than the wild-type enzyme. OP- or carbamate-resistant strains containing AChE with reduced sensitivity are shown to have modified binding or catalytic properties towards substrates and inhibitors (Fournier and Mutero, 1994; McCaffery, 1999; Gunning and Moores, 2001).

Generally, strain SPOD-EX E-98 (1686 mOD/min/mg protein) showed a 2.2-fold higher AChE activity than the susceptible strain SPOD-EX S (784 mOD/min/mg protein), but the biochemical assay used was not sensitive enough for detecting AChE activity in single 2nd instar larvae. Therefore, 3rd instar larvae were used for the determination of frequency distributions of both *S. exigua* strains. The obtained activity patterns of the two strains were close together, but clearly separated. In comparison, the susceptible strain SPOD-EX S was more homogeneous than strain SPOD-EX E-98.

Furthermore, AChE was successfully purified from strains SPOD-EX S and SPOD-EX E-98 using 660 and 330 mg of 2nd instar larvae, respectively. The procainamide affinity chromatography purification step yields AChE of high purity from both strains, but constantly higher amounts of AChE from the resistant strain SPOD-EX E-98. This result was due to a higher affinity between SPOD-EX E-98 AChE and the affinity ligand. Thus, structural modification(s) in the AChE form of strain SPOD-EX E-98 could explain the higher yield and affinity.

The Michaelis-Menten kinetics revealed a 2.2-fold higher V_{\max} -value (2821 mOD/min/mg protein) and a 10.7-fold higher V_{\max} -value (11015 mOD/min/mg protein) in the resistant strain SPOD-EX E-98 in comparison to the sensitive forms of AChE (strain SPOD-EX S) using mass homogenates and purified enzyme, respectively.

Additionally, AChE from strain SPOD-EX E-98 exhibited a lower K_m -value (140 μ M) than the enzyme from the susceptible strain (211 μ M). The K_m -value determined with purified AChE was quite lower than that one obtained with AChE from crude homogenates.

Similar K_m -values were reported for AChE from *C. pipiens* (Raymond *et al.*, 1986), *P. xylostella* (Wu *et al.*, 2004), and heads of adults of *Spodoptera frugiperda* (Yu *et al.*, 2003) and *S. exigua* (Byrne and Toscano, 2001). A methomyl-resistant *S. frugiperda* strain has an increased affinity of AChE, reflected also by a lower K_m - and a higher V_{\max} -value (Yu *et al.*, 2003).

The higher turnover of the artificial substrate AChI, equal with a lower K_m -value and the resulting higher V_{\max} in strain SPOD-EX E-98 suggests a structural modification of AChE in this strain. Smissaert (1964) was the first who reported insensitivity of AChE as a mechanism of resistance to OPs in the spider mite *T. urticae*. The frequent use of OPs and carbamates over the last 60 years resulted in an increase of a target-site resistance to these compounds.

To date, altered AChE, resulting in an insecticide-insensitive enzyme, is one of the major mechanisms of OP and carbamate resistance in more than 25 insect and mite species (Fournier and Mutero 1994; Russell *et al.*, 2004).

Molecular studies have now identified several point mutations in the primary structure of AChE conferring insecticide resistance. These structural alternations of AChE are based on a variety of amino acid substitutions, which were subject of several reviews (Fournier and Mutero, 1994; Feyereisen, 1995; Russell *et al.*, 2004). In *D. melanogaster* up to five nucleotide point mutations, either alone or in combination, were associated with the reduction of AChE sensitivity (Mutero *et al.*, 1994). AChE, encoded by the *ace* gene, occurs as just one gene in the higher Diptera, whereas other insects and mites have two. Recently, Russell *et al.* (2004) postulated two major classes of target-site insensitivity mutations conferring resistance to OPs and carbamates.

No significant differences in the enzyme inhibition (mass homogenate) was observed between both strains using the organophosphate paraoxon-ethyl (IF=1.4). On the other hand, the strain SPOD-EX E-98 expressed a high insensitivity to methamidophos (IF=9.8), corresponding to high resistance factors (>5.5 and 17.8) in the bioassays.

AChE from strain SPOD-EX E-98 was 9.2- and 4.6-fold less sensitive to inhibition by methomyl and thiodicarb, respectively, using mass homogenates. Similar results were obtained with the affinity-purified AChE. In comparison, the inhibition of AChE from mass homogenates by the three carbamates exhibited slightly higher IC₅₀-values as used purified AChE as enzyme source.

Biochemical studies on AChE from several insect species showed insensitivity to inhibition by OPs and carbamates (Berrada *et al.*, 1994; Moores *et al.*, 1996; Guedes *et al.*, 1997; Charpentier and Fournier, 2001; Yoo *et al.*, 2002) including lepidopteran species (Brown and Bryson, 1992; Yu, 1992; Van Laecke *et al.*, 1995; Gunning *et al.*, 1996a; Byrne and Toscano, 2001; Yu *et al.*, 2003; Baek *et al.*, 2005). These observations in many cases are confirmed with the corresponding *in vivo* bioassays.

In contrast, it was shown here that AChE from strain SPOD-EX E-98 was ca. 110-fold more sensitive to inhibition by carbofuran, when compared with AChE from the susceptible strain. This phenomenon is called “negative cross-insensitivity”, i.e. an inhibitor is more active against AChE of the resistant strain than against AChE from the sensitive strain. Additionally, negative cross-insensitivity was also detected with the standard inhibitors BW284c51 (IF=0.7) and eserine (IF=0.011) in mass homogenates of SPOD-EX E-98 larvae. BW284c51 and eserine are well-known as potent non-insecticidal standard AChE inhibitors. A qualitative change in the AChE of strain SPOD-EX E-98 could explain the insensitivity to carbamate and OP insecticides and on the other hand the negative cross-insensitivity to carbofuran, eserine and BW284c51.

Negative cross-resistance of altered AChE associated with resistance to OPs and carbamates is quite common in some species including Lepidoptera (Raymond *et al.*, 1986; Brown and Bryson, 1992; Zhu and Clark, 1995; Yu *et al.*, 2003) and was mainly detected with biochemical methods.

Such an unusual pattern of AChE resistance to carbofuran has also been observed in strains of *Aphis gossypii* (Villatte *et al.*, 1999; Benting and Nauen, 2004) and *Rhyzopertha dominica* (Guedes *et al.*, 1997).

The negative cross-insensitivity of AChE from strain SPOD-EX E-98 was also confirmed by the *in vivo* bioassay data, where carbofuran was more active against larvae of the resistant strain (RF of <0.3). It might be possible to break resistance through such compounds which show a negative cross-insensitivity, so carbofuran is a potential candidate for resistance management programs as shown earlier in other species and suggested by Brown (1961).

The broad-spectrum of insecticide resistance observed in strain SPOD-EX E-98 was due to multiple resistance mechanisms, including the possible detoxification of these insecticides by esterases, monooxygenases and an altered AChE.

In conclusion, the four used biochemical assays used for the determination of GST, AChE, CE and ECOD activities offer highly sensitive and accurate monitoring techniques in early instars (2nd) of *S. exigua*.

5.5 Establishment of a bioassay-kit for a worldwide monitoring

Flubendiamide (NNI-0001) is the first member of a novel class of insecticides, the phthalic acid diamides, and is active against a broad range of lepidopteran insects (Tohnishi *et al.*, 2005; Nauen, 2006). This class of chemistry shows a new mode of action, they act as ryanodine receptor modulators in the insect nervous system.

Another purpose of this study was to investigate the efficacy of flubendiamide in field populations worldwide, in order to monitor for baseline susceptibility. For a worldwide monitoring in the year 2004, a very robust and simple bioassay, based on the artificial diet bioassay was established. The collectors in the different countries obtained a “ready-to-use” kit with a diagnostic dose of flubendiamide and a control plate. The field persons should only collected larvae of the correct size and then putting one larva into each well of the provided plates.

The focus was on two species, *S. exigua* and *H. armigera*, collected in five countries (Australia, Mexico, Thailand, Turkey, and Spain). However, 14 field populations and 4 laboratory strains were tested in total.

The diagnostic concentration of 1 mg litre⁻¹ flubendiamide in the present monitoring assay was based on the combined bioassay data of one *H. armigera* strain and two *S. exigua* laboratory strains. This composite EC₉₉-value will serve as diagnostic rate to carry out future monitoring projects in these two lepidopteran species.

Normally, monitoring studies are done in single regions or countries. The test populations are usually are send to one place for testing and sometimes the populations must be maintained in order to get the right developmental stage/instar and quantity. Local monitoring programs are very well described in the literature, and are carried out on the initiative of public institutions within research projects, industry or extension laboratories. Such studies also carried out for *S. exigua* (Brewer *et al.*, 1990; Kerns *et al.*, 1998; Mascarenhas *et al.*, 1998; Moulton *et al.*, 2000) and *H. armigera* (Glenn *et al.*, 1994; Martin *et al.*, 2000; Kranthi *et al.*, 2001;

Torres-Vila *et al.*, 2002; Ahmad, 2004) with different commercial insecticides, e.g. pyrethroids.

For a worldwide monitoring, this procedure is too time consuming and laboratory intensive, independent of the necessity of import- and export-licences for living material, so sending prepared plates with insecticide seem to be a good alternative.

The monitoring experiments performed in the field indicated that flubendiamide was very effective against 2nd to beginning 3rd instar larvae and a mean mortality/efficacy of approximately 93% (SD 12) was obtained (all strains combined). Eighteen flubendiamide-population combinations were tested and twelve of the field populations were fully susceptible and whereas four populations showed a slight variation in flubendiamide sensitivity (83 - 92% efficacy). Only two strains, one of each species, expressed ca. 65% efficacy and a somewhat reduced response to flubendiamide in this monitoring program. The use of bigger larvae or higher fitness effects of field strains compared with laboratory-reared strains might account for this variation in response in some of the tested populations.

This artificial diet based monitoring method looks like an excellent and simple tool for monitoring and analysis of the risk of resistance development in lepidopteran species, especially in view of global investigations with new and old insecticides.

5.6 Resistance risk assessment of flubendiamide

The baseline susceptibilities towards flubendiamide of all four lepidopteran strains were similar as shown by the artificial diet bioassay using 2nd instar larvae. The dose-response curves demonstrated a high degree of homogeneity between the species, expressed by only a 2-fold difference in EC₅₀-values. Flubendiamide was most effective against strain HELI-VI, followed by HELI-AR, SPOD-EX E-98 and SPOD-EX S. The corresponding EC₉₉-values for flubendiamide against 2nd instar larvae of the three species can be used as discriminating concentration to monitor field populations for possible flubendiamide resistance in the future. Flubendiamide was tested with two bioassay techniques, a spray bioassay and an artificial diet bioassay, using 2nd instar larvae. Insecticides from eleven chemical groups representing the main competitors and mode of action groups on the insecticide market were tested.

In summary, the three laboratory strains, HELI-AR, HELI-VI and SPOD-EX S, behaved similar in the different bioassays and according to their susceptibility to the different insecticides. Emamectin was found to be the most toxic compound in all cases, followed by a group of three compounds: flubendiamide, deltamethrin and indoxacarb. These four

insecticides exhibited an outstanding potency/efficacy with EC_{50} -values lower than 1 mg litre⁻¹.

In both used bioassay types, flubendiamide was even slightly more active against the multi-resistant strain SPOD-EX E-98 than the susceptible strain SPOD-EX S. In addition, flubendiamide was not cross-resistant to pyrethroids, OPs, carbamates, BPU, endosulfan and indoxacarb in *S. exigua*.

Tohnishi *et al.* (2005) described also the excellent efficacy of flubendiamide against a resistant *P. xylostella* strain, showing high resistance ratios to pyrethroids, BPU, OPs and carbamates. Against the resistant strain, flubendiamide exhibited a level of activity in the range as a susceptible reference strain.

No evidence for resistance development against flubendiamide was found yet, so flubendiamide is well suited for resistance management programs.

The new insecticide was shown to be very active against all five developmental stages of *S. exigua*, *H. armigera* and *H. virescens*. The EC_{50} -values for the 1st instar was calculated to be 0.07 mg litre⁻¹ and increases ca. 11-fold when applied to the last instar (1 mg litre⁻¹). In comparison, during larval development the weight of the larvae increases ca. 500-fold for *S. exigua* and ca. 1000-fold for *H. armigera* and *H. virescens*. Generally, the both heliothine species are a little bit more sensitive to flubendiamide compared with *S. exigua*, and no differences were observed between the susceptible and a multi-resistant *S. exigua* strain in their response to flubendiamide.

In comparison to the two bioassays on 2nd instar larvae, strain SPOD-EX E-98 was also a little bit more susceptible to flubendiamide using topical application on 5th instar larvae. Additionally, the two esterase inhibitors, DEF and profenofos, had no significant effects on flubendiamide toxicity in both *S. exigua* strains. Only pre-treatment with the monooxygenase inhibitor PBO resulted in negligible effects on flubendiamide toxicity in strain SPOD-EX S (SF=3.5) and strain SPOD-EX E-98 (SF=2).

The synergistic effect of PBO is independent of the higher monooxygenase activity in strain SPOD-EX E-98 (6-fold; 5th instar). PBO is known to facilitate insecticide penetration through the cuticle of some insects (Sun and Johnson, 1972; Kennaugh *et al.*, 1993; Gunning *et al.*, 1995); and a similar behaviour in combination with flubendiamide is a possible explanation of the obtained minimal synergistic effect in both strains.

Advances in the recent time have promoted a shift from reactive to proactive resistance efforts, e.g. the integration of resistance risk analysis in registration dossiers for new

insecticides, like flubendiamide. This is important in view of the tremendous increase of resistance cases in pest species against almost all commercially used insecticides.

The results of this study and the novel mode of action of flubendiamide suggested that this compound is a strong new option in future resistance management programs to control lepidopteran pest species. Additionally, alternation strategies, including flubendiamide, will reduce the selection pressure on field populations and may help to delay the development of insecticide resistance.

Finally, flubendiamide will be an excellent and potential partner in resistance management strategies, with no tendency to select resistance in pest insects in the moment.

6 SUMMARY

Noctuid species, such as the beet armyworm *Spodoptera exigua*, the cotton bollworm *Helicoverpa armigera* and the tobacco budworm *Heliothis virescens*, are well-known pests in many agricultural cropping systems worldwide; however of economic importance are the phytophagous larvae of these species. The extensive and widespread use of insecticides against these species has led to the development of resistance against almost all commercially used compounds, including new insecticides such as spinosad.

The focus of this thesis was on the novel lepidopteran specific compound flubendiamide, to get a detailed overview about the efficacy using different kinds of bioassays for a resistance risk assessment. On the other hand, the underlying possible resistance mechanisms of a *S. exigua* strain from southern Spain was investigated on the toxicological, biochemical, pharmacokinetic and molecular level.

The basic of all further experiments was two bioassay techniques, a leaf-disc spray application and an artificial diet bioassay, on 2nd instar larvae. Flubendiamide and 11 competitors with different mode of actions were tested on three susceptible laboratory strains (HELI-AR, HELI-VI, SPOD-EX S) and one field strain from Spain (SPOD-EX E-98). The aim was to get baseline susceptibilities of the three noctuid species and additionally the resistance profile of strain SPOD-EX E-98 against the different insecticides.

The results of the two bioassay techniques were comparable with each other, emamectin shown the highest efficacy followed by low EC₅₀-values for flubendiamide, deltamethrin and indoxacarb.

Additionally, flubendiamide expressed an excellent efficacy against all five larval stages of all four noctuid strains.

An interesting cross-resistance pattern against insecticides with different mode of actions demonstrated the *S. exigua* strain SPOD-EX E-98, and can be called as “multi-resistant”.

High resistance to three classes of insecticides, pyrethroids, benzoylphenyl ureas and carbamates/organophosphates, was detected in this strain, also moderate resistance levels to endosulfan and indoxacarb.

The artificial diet bioassay was used for a worldwide monitoring, because of the robust and simple handling. It was used a diagnostic concentration (1 mg litre⁻¹) of flubendiamide, and resulting in a mean efficacy of 93% in 18 test populations of *S. exigua* and *H. armigera*.

The *in vivo* application study with the synergist PBO (monooxygenase inhibitor) has shown an additional participation of this enzyme system towards the deltamethrin resistance in the *S. exigua* strain SPOD-EX E-98.

Additionally, PBO and two esterase inhibitors (DEF and profenofos) had no effect to the resistance level of triflumuron (benzoylphenyl urea) and so target-site resistance is likely in this case.

Using molecular biological methods, a point mutation (*kdr*) in the voltage-gated sodium channel of the resistant strain SPOD-EX E-98 was detected, this channel is the target of the pyrethroids. This target-site resistance is particularly responsible for the extremely high resistance factor (~900) of the pyrethroid deltamethrin detected in the bioassays.

In order to investigate the pharmacokinetic profiles of deltamethrin, triflumuron and flubendiamide in *S. exigua* larvae (5th instar) topically applied radiolabelled [¹⁴C]-compounds were used. No differences in penetration or excretion of the compounds were observed between the two strains (SPOD-EX S and E-98). This suggests that physiological changes have not influence as a possible mechanism of deltamethrin and triflumuron resistance.

Four biochemical markers, carboxylesterases (CEs), cytochrome P₄₅₀-dependent monooxygenases (monooxygenases), glutathione S-transferases (GSTs) and acetylcholinesterases (AChEs), were investigated in both *S. exigua* strains. These enzyme systems are known to be linked with metabolic detoxification/resistance to diverse insecticides, but in the case of AChE it is a target-site resistance to organophosphates and carbamates.

With the exception of GST, in the multi-resistant SPOD-EX E-98 strain was found significantly higher enzyme activities to the other three marker enzymes.

The higher CE activity in the multi-resistant strain SPOD-EX E-98 was further investigated, using a native PA-gel electrophoresis to obtaining the iso-enzyme banding patterns of both

strains. In comparison, the strain SPOD-EX E-98 exhibited an additional thick band and it was not possible to inhibit this band *in vitro* through the synergist DEF (esterase inhibitor). It is possible that this result is involved in resistance, but only further investigations could clarify the exact role of the additional band in this resistant strain.

The AChE of both *S. exigua* strains was used for *in vitro* inhibition studies. The resistant strain SPOD-EX E-98 was insensitive against several organophosphates and carbamates compared with strain SPOD-EX S. Only one exception was detected, the AChE of the resistant strain SPOD-EX E-98 was more sensitive to carbofuran than the enzyme from strain SPOD-EX S. This phenomenon of “negative cross-insensitivity” is generally correlated with an altered substrate binding site of the AChE. Further investigations of kinetic parameters (V_{\max} - and K_m -values) exhibited a higher turnover of the substrate in strain SPOD-EX E-98; this should be only deriving from an alternation of the AChE-enzyme structure.

The bioassays confirmed these results and so the resistance mechanism of the two chemical classes (organophosphates and carbamates) is an altered AChE in the resistant strain.

In conclusion, the new insecticide flubendiamide is very active against all developmental instars and showing an outstanding efficacy against all four used lepidopteran strains, including the multi-resistant *S. exigua* strain SPOD-EX E-98. Additionally, the synergist studies and the worldwide monitoring have shown no tendency to development of resistance, and so flubendiamide is a new strong option for resistance management programs in the future.

The occurrence of multi-resistant strains, such as SPOD-EX E-98, is well-known, because of high selection pressure through the intensive and extensive use of insecticides in the field. This study shows the involvement of one or more resistance mechanisms for the individual resistance cases. Therefore, it is important to observe each chemical group independently and additionally to have a range of well established methods (bioassays and diagnostic of resistance mechanisms) for the insect species of interest.

7 ZUSAMMENFASSUNG

Schädlinge der Familie der Noctuidae, wie z.B. die Zuckerrübeneule *Spodoptera exigua*, der Baumwollkapselwurm *Helicoverpa armigera* und die Baumwolleule *Heliothis virescens* sind weltweit in vielen agronomischen Anbausystemen bekannt, wobei die phytophagen Larven als Verursacher den wirtschaftlichen Schaden herbeiführen. Der häufige und weit verbreitete Einsatz von Insektiziden in den genannten Arten führte zu einer Resistenzentwicklung gegenüber fast allen kommerziell erhältlichen Wirkstoffen, dieses schließt auch neuere Insektizide wie Spinosad ein.

Der Fokus dieser Arbeit lag auf einem neuen insektiziden Wirkstoff, Flubendiamide, der spezifisch gegen Lepidopteren wirkt. Verschiedene Arten von Biotests wurden eingesetzt um einen Überblick über das Risiko einer Resistenzentwicklung zu bekommen. Des Weiteren lag das Interesse auf einem *S. exigua* Stamm aus Südspanien, dessen mögliche Resistenzmechanismen auf biochemischer, pharmakokinetischer und molekularer Ebene untersucht wurden.

Die Grundlage für alle weiteren Versuche bildeten zwei Biotestsysteme, eine Sprühapplikation auf Blattmaterial und ein Kunstfutter-Biotest, die am zweiten Larvenstadium durchgeführt wurden. Flubendiamide und 11 Konkurrenzprodukte mit unterschiedlichen Wirkmechanismen wurden an drei sensiblen Laborstämmen (HELI-AR, HELI-VI, SPOD-EX S) und einem Freilandstamm aus Spanien (SPOD-EX E-98) getestet.

Ziel war es die Basisdaten für die drei sensiblen Stämme und das Resistenzprofil für den Stamm SPOD-EX E-98 gegenüber den verschiedenen Insektiziden herauszuarbeiten, wobei beide Testsysteme vergleichbare Ergebnisse erzielten.

Emamectin zeigte die beste Wirkung dicht gefolgt von niedrigen EC_{50} -Werten für Flubendiamide, Deltamethrin und Indoxacarb.

Zusätzlich zeigte Flubendiamide eine exzellente Wirkung an allen fünf Larvenstadien der vier verschiedenen Noctuiden-Stämme.

Der *S. exigua* Stamm SPOD-EX E-98 zeigte sich interessanterweise kreuzresistent gegenüber verschiedenen Insektiziden mit unterschiedlichen Wirkmechanismen und kann somit als „multiresistent“ bezeichnet werden.

Eine starke Resistenz gegenüber den drei Insektizidklassen, Pyrethroide, Benzoylharnstoffe und Carbamate/Organophosphate wurde für diesen Stamm festgestellt, zusätzlich moderatere Resistenzfaktoren für die Wirkstoffe Endosulfan und Indoxacarb.

Der Kunstfutter-Biotest erwies sich als robust und sehr einfach in der Handhabung, sodass dieser mit einer diagnostischen Konzentration von Flubendiamide (1 mg/Liter) in einem weltweiten Resistenz-Monitoring zum Einsatz kam, wobei ein durchschnittlicher Wirkungsgrad von 93% bei 18 Testpopulationen (*S. exigua* und *H. armigera*) erreicht wurde.

Die *in vivo* Versuche mit dem Synergisten PBO (Monooxygenase-Inhibitor) zeigten eine zusätzliche Beteiligung dieses Enzymsystem an der vorhandenen Deltamethrin-Resistenz des *S. exigua* Stammes SPOD-EX E-98.

Zusätzlich konnte kein Effekt, sowohl mit PBO als auch mit den Esterase Inhibitoren (DEF und Profenofos), auf den Resistenzlevel von Triflumuron (Benzoylharnstoff) erzielen werden. Daher muss in diesem Fall auch eine Target-Site-Resistenz angenommen werden.

Mit molekularbiologischen Methoden konnte eine Punktmutation (*kdr*) im spannungsabhängigen Natriumkanal, dem Wirkort der Pyrethroide, des Stammes SPOD-EX E-98 ermittelt werden. Diese Target-Site-Resistenz ist teilweise für den extrem hohen Resistenzfaktor (~900) des Pyrethroids Deltamethrin verantwortlich, der in den Biotests ermittelt wurde.

In weiteren Experimenten wurde das pharmakokinetische Profil von topikal applizierten radioaktiv markierten [¹⁴C]-Wirkstoffen (Deltamethrin, Triflumuron, Flubendiamide) in *S. exigua* Larven (5. Stadium) nachvollzogen. Zwischen den beiden Stämmen (SPOD-EX S und E-98) ergab sich keine veränderte Aufnahme oder Exkretion der Wirkstoffe, sodass gegenüber Deltamethrin und Triflumuron eine Veränderung auf physiologischer Ebene als Resistenzmechanismus auszuschließen ist.

In den zwei *S. exigua* Stämmen wurden vier biochemische Marker, Carboxylesterasen (CEs), Cytochrom P₄₅₀-abhängige Monooxygenasen (Monooxygenasen), Glutathion S-Transferasen (GSTs) und Acetylcholinesterasen (AChEs), untersucht, von denen bekannt ist, dass sie an einer metabolischen Entgiftung von diversen Insektiziden beteiligt sind. Dabei handelt es sich im Falle der AChE um eine Target-Site-Resistenz für Organophosphate und Carbamate.

Das Ergebnis zeigte, außer bei GSTs, in allen anderen drei Enzymsystemen signifikant erhöhte Aktivitäten des multi-resistenten Stammes SPOD-EX E-98.

Zusätzlich zu der erhöhten CE-Aktivität des multi-resistenten Stammes SPOD-EX E-98 konnten mittels nativer PA-Gelelektrophorese die Isoenzym-Bandenmuster für beide *S. exigua* Stämme bestimmt werden. Im Vergleich der beiden Stämme fiel eine zusätzliche

starke Bande im Stamm SPOD-EX E-98 auf, die auch nicht *in vitro* durch den Synergisten DEF (Esterase-Inhibitor) inhibiert werden konnte.

Die zusätzlich gefundene Bande kann möglicherweise als Resistenzfaktor in dem resistenten Stamm eine Rolle spielen, hierzu sind aber noch weitere Untersuchungen nötig.

In vitro Inhibierungsstudien von AChE aus beiden *S. exigua* Stämmen zeigten das der resistente Stamm SPOD-EX E-98 unempfindlicher gegenüber Organophosphaten und Carbamaten als der Stamm SPOD-EX S ist, nur im Bezug auf Carbofuran zeigte sich die AChE aus dem Stamm SPOD-EX E-98 sensibler als das Enzym aus dem Stamm SPOD-EX S. Dieses Phänomen der „negativen Kreuzinsensitivität“ wird generell mit einer veränderten Substratbindungsstelle der AChE in Verbindung gebracht. Weitere Untersuchungen der kinetischen Parameter (V_{\max} - und K_m -Werte) zeigten zusätzlich eine erhöhte Substratumsetzung in dem Stamm SPOD-EX E-98, die sich nur auf eine veränderte Struktur des AChE-Enzyms zurückzuführen lässt.

Dieses Ergebnis wurde in den Biotests bestätigt und kann als Resistenzmechanismus für diese beiden Wirkstoffgruppen (Organophosphate und Carbamate) angesehen werden.

Zusammenfassend kann gesagt werden, dass das neue Insektizid Flubendiamide außergewöhnlich gut gegen alle vier getesteten Lepidopteren-Stämme wirkt, eingeschlossen dem multi-resistenten *S. exigua* Stamm SPOD-EX E-98. Außerdem erzielt es in allen Larvenstadien eine sehr gute Wirkung. Zusätzlich fand sich in den Synergismus-Experimenten und im weltweiten Monitoring kein Hinweis auf eine Resistenzentwicklung, so dass Flubendiamide eine neue schlagkräftige Option für zukünftige Programme im Resistenz Management sein wird.

Der hohe Selektionsdruck durch den intensiven und weit verbreiteten Einsatz von Insektiziden im Feld bewirkt, dass das Auftreten von multi-resistenten Stämmen, wie z.B. der Stamm SPOD-EX E-98, keine Seltenheit ist.

Diese Studie zeigt auch, dass die einzelnen Resistenzereignisse sich auf ein oder mehrere verschiedene Resistenzmechanismen gründen können. Daher ist es wichtig die einzelnen chemischen Insektizidgruppen getrennt voneinander zu betrachten und für jede relevante Spezies die entsprechenden Methoden für Biotests und Diagnostik von Resistenzmechanismen bereitzuhalten.

8 REFERENCES

- Abalis, I.M., Eldefrawi, M.E. and Eldefrawi, A.T. (1985). High-affinity stereospecific binding of cyclodiene insecticides and γ -hexachlorocyclohexane to γ -aminobutyric acid receptors of rat brain. *Pestic. Biochem. Physiol.* **24**, 95-102.
- Abbott, W.S. (1925). A method of computing effectiveness of an insecticide. *J. Econ. Entomol.* **18**, 256-267.
- Abd-Elghafar, S.F., Abo-Elghar, G.E., and Knowles, C.O. (1994). Fenvalerate penetration, metabolism, and excretion in pyrethroid-susceptible and resistant *Heliothis virescens* (Lepidoptera: Noctuidae). *J. Econ. Entomol.* **87**, 872-878.
- Abd-Elghafar, S.F. and Knowles, C.O. (1996). Pharmacokinetic of fenvalerate in laboratory and field strains of *Helicoverpa zea* (Lepidoptera: Noctuidae). *J. Econ. Entomol.* **89**, 590-593.
- Ahmad, M. and McCaffery, A.R. (1999). Penetration and metabolism of trans-cypermethrin in a susceptible and a pyrethroid-resistance strain of *Helicoverpa armigera*. *Pestic. Biochem. Physiol.* **65**, 6-14.
- Ahmad, M., Hollingworth, R.M. and Wise, J.C. (2002). Broad-spectrum insecticide resistance in obliquebanded leafroller *Choristoneura rosaceana* (Lepidoptera: Tortricidae) from Michigan. *Pest Manag. Sci.* **58**, 834-838.
- Ahmad, M. (2004). Potentiation/antagonism of deltamethrin and cypermethrins with organophosphate insecticides in the cotton bollworm, *Helicoverpa armigera* (Lepidoptera: Noctuidae). *Pestic. Biochem. Physiol.* **80**, 31-42.
- Ahmadian, A., Gharizadeh, B., Gustafsson, A.C., Sterky, F., Nyrén, P., Uhlén, M. and Lundberg, J. (2000). Single-nucleotide polymorphism analysis by pyrosequencing. *Anal. Biochem.* **280**, 103-110.
- Aldosari, S.A., Watson, T.F., Sivasupramaniam, S. and Osman, A.A. (1996). Susceptibility of field populations of beet armyworm (Lepidoptera: Noctuidae) to cyfluthrin, methomyl, and profenofos, and selection of resistance to cyfluthrin. *J. Econ. Entomol.* **89**, 1359-1363.
- Alon, M., Benting, J., Lueke, B., Ponge, T., Alon, F. and Morin, S. (2006). Multiple origins of pyrethroid resistance in sympatric biotypes of *Bemisia tabaci* (Hemiptera: Aleyrodidae). *Insect Biochem. Molec. Biol.* **36**, 71-79.
- Argentine, J.A., Jansson, R.K., Starner, V.R. and Halliday, W.R. (2002). Toxicities of emamectin benzoate homologues and photodegradates to Lepidoptera. *J. Econ. Entomol.* **95**, 1185-1189.
- Armes, N.J., Jadhav, D.R. and DeSouza, K.R. (1996). A survey of insecticide resistance in *Helicoverpa armigera* in the Indian subcontinent. *Bull. Entomol. Res.* **86**, 499-514.
- Armes, N.J., Wightman, J.A., Jadhav, D.R. and Ranga Rao, G.V. (1997). Status of insecticide resistance in *Spodoptera litura* in Andhra Pradesh, India. *Pestic. Sci.* **50**, 240-248.
- Armstrong, R.N. (1991). Glutathione S-transferases: reaction mechanism, structure and function. *Chem. Res. Toxicol.* **4**, 131-140.
- Armstrong, R.N. (1997). Structure, catalytic mechanism and evolution of the glutathione S-transferases. *Chem. Res. Toxicol.* **10**, 2-18.
- Auda, M., El Saily, F.M. and Degheele, D. (1991). Toxicity, retention and distribution of [14 C]hexaflumuron in the last larval instar of *Leptinotarsa decemlineata*, *Spodoptera littoralis* and *Spodoptera exigua*. *Pestic. Sci.* **32**, 419-426.

- Baek, J.H., Kim, J.I., Lee, D.-W., Chung, B.K., Miyata, T. and Lee, S.H. (2005). Identification and characterization of *ace1*-type acetylcholinesterase likely associated with organophosphate resistance in *Plutella xylostella*. *Pestic. Biochem. Physiol.* **81**, 164-175.
- Benting, J., Häuser-Hahn, R., Nauen, R. and Beffa, R. (2004). Molecular diagnosis of resistance. *Pflanzenschutz-Nachrichten Bayer* **57**, 78-85.
- Benting, J. and Nauen, R. (2004). Biochemical evidence that an S431F mutation in acetylcholinesterase-1 of *Aphis gossypii* mediates resistance to pirimicarb and omethoate. *Pest Manag. Sci.* **60**, 1051-1055.
- Bergé, J.-B., Feyereisen, R. and Amichot, M. (1999). Cytochrome P450 monooxygenases and insecticide resistance in insects. In: *Insecticide Resistance: From Mechanisms to Management*. (Eds. I. Denholm, J.A. Pickett and A.L. Devonshire), CABI Publishing London, pp. 25-29.
- Berrada, S., Fournier, D., Cuany, A. and Nguyen, T.X. (1994). Identification of resistance mechanisms in a selected laboratory strain of *Cacopsylla pyri* (Homoptera: Psyllidae): altered acetylcholinesterase and detoxifying oxidases. *Pestic. Biochem. Physiol.* **48**, 41-47.
- Black, B.C., Hollingworth R.M., Ahammadsahib, K.I., Kukel, C.D. and Donovan, S. (1994). Insecticidal action and mitochondrial uncoupling activity of AC-303,630 and related halogenated pyrroles. *Pestic. Biochem. Physiol.* **50**, 115-128.
- Bloomquist, J.R. (1993). Neuroreceptor mechanisms in pyrethroid mode of action and resistance. *Rev. Pestic. Toxicol.* **2**, 185-230.
- Bloomquist, J.R. (2001). GABA and glutamate receptors as biochemical sites for insecticide action. In: *Biochemical Sites of Insecticide Action and Resistance*. (Ed. I. Ishaaya), Springer-Verlag, Berlin, Heidelberg, pp. 17-41.
- Bouvier, J.-C., Boivin, T., Beslay, D. and Sauphanor, B. (2002). Age-dependent response to insecticides and enzymatic variation in susceptible and resistant codling moth larvae. *Arch. Insect Biochem. Physiol.* **51**, 55-66.
- Bradford, J.P. (1976). A rapid and sensitive method for the quantitation of microgram quantities of protein utilising the principle of protein-dye binding. *Anal. Biochem.* **72**, 248-253.
- Brewer, M.J. and Trumble, J.T. (1989). Field monitoring for insecticide resistance in beet armyworm (Lepidoptera: Noctuidae). *J. Econ. Entomol.* **82**, 1520-1526.
- Brewer, M.J., Trumble, J.T., Alvarado-Rodriguez, B. and Chaney, W.E. (1990). Beet armyworm (Lepidoptera: Noctuidae) adult and larval susceptibility to three insecticides in managed habitats and relationship to laboratory selection for resistance. *J. Econ. Entomol.* **83**, 2136-2146.
- Brown, A.W.A. (1961). Negatively-correlated insecticides: A possible countermeasure for insecticide resistance. *Pest Control* **29**, 24.
- Brown, T.M. and Bryson, P.K. (1992). Selective inhibitors of methyl parathion-resistant acetylcholinesterase from *Heliothis virescens*. *Pestic. Biochem. Physiol.* **44**, 155-164.
- Byrne, F.J. and Devonshire, A.L. (1993). Insensitive acetylcholinesterase and esterase polymorphism in susceptible and resistant populations of the tobacco whitefly, *Bemisia tabaci*. *Pestic. Biochem. Physiol.* **45**, 34-42.
- Byrne, F.J. and Toscano, N.C. (2001). An insensitive acetylcholinesterase confers resistance to methomyl in the beet armyworm *Spodoptera exigua* (Lepidoptera: Noctuidae). *J. Econ. Entomol.* **94**, 524-528.

- Carlson, G.R., Dhadialla, T.S., Hunter, R., Jansson, R.K., Jany, C.S., Lidert, Z. and Slawecki, R.A. (2001). The chemical and biological properties of methoxyfenozide, a new insecticidal ecdysteroid agonist. *Pest Manag. Sci.* **57**, 115-119.
- Charpentier, A. and Fournier, D. (2001). Levels of total acetylcholinesterase in *Drosophila melanogaster* in relation to insecticide resistance. *Pestic. Biochem. Physiol.* **70**, 100-107.
- Dauterman, W.C. (1985). Insect metabolism: extramicrosomal. In: *Comprehensive Insect Physiology, Biochemistry and Pharmacology*. (Eds. G.A. Kerkut and L.I. Gilbert). Pergamon, Oxford, U.K. Vol. 12, pp. 713-730.
- Delorme, R., Fournier, D., Chaufaux, J., Cuany, A., Bride, J.M., Auge, D. and Berge, J.B. (1988). Esterases metabolism and reduced penetration are causes of resistance to deltamethrin in *Spodoptera exigua* HUB (Noctuidae; Lepidoptera). *Pestic. Biochem. Physiol.* **32**, 240-246.
- DeSousa, G., Cuany, A., Brun, A., Amichot, M., Rahmani, R. and Bergé, J.-B. (1995). A microfluorometric method for measuring ethoxycoumarin-O-deethylase activity in individual *Drosophila melanogaster* abdomens: interest for screening resistance in insect populations. *Analyt. Biochem.* **229**, 86-91.
- Dong, K. (1997). A single amino acid change in the para sodium channel protein is associated with knockdown-resistance (*kdr*) to pyrethroid insecticides in German cockroaches. *Insect Biochem. Molec. Biol.* **27**, 93-100.
- Dong, K. (2003). Voltage-gated sodium channels as insecticide targets. In: *Chemistry of Crop Protection. Progress and Prospects in Science and Regulation*. (Eds. G. Voss and G. Ramos), Wiley-VCH, Weinheim, Germany, pp. 167-176.
- Dong, K. (2007). Insect sodium channels and insecticide resistance. *Invert. Neurosci.* **7**, 17-30.
- Ebbinghaus-Kintscher, U., Lümmer, P., Lobitz, N., Schulte, T., Funke, C., Fischer, R., Masaki, T., Yasokawa, N. and Tohnishi, M. (2005). Phthalic acid diamides activate ryanodine-sensitive Ca²⁺ release channels in insects. *Cell Calcium* **39**, 21-33.
- Ebbinghaus-Kintscher, U., Lümmer, P., Raming, K., Masaki, T. and Yasokawa, N. (2007). Flubendiamide, the first insecticide with a novel mode of action on insect ryanodine receptors. *Pflanzenschutz-Nachrichten Bayer* **60**, 117-140.
- Eldefrawi, M.E., Miskus, R. and Sutchter, V. (1960). Methylenedioxyphenyl derivates as synergists for carbamate insecticides on susceptible, DDT-, and parathion-resistant houseflies. *J. Econ. Entomol.* **53**, 231-234.
- Elliott, M., Farnham, A.W., Janes, N.F., Needham, P.H. and Pulman, D.A. (1974). Synthetic insecticide with a new order of activity. *Nature* **248**, 710-711.
- Elliott, M., Janes, N.F. and Potter, C. (1978). The future of pyrethroids in insect control. *Ann. Rev. Entomol.* **23**, 443-469.
- Ellman, G.L., Courtney, K.D., Andres, V. and Featherstone, R.M. (1961). A new and rapid colorimetric determination of acetylcholinesterase activity. *Biochem. Pharmacol.* **7**, 88-95.
- Emam, A.K., Degheele, D. and Van Outryve D'ydwalle, Y. (1988). Distribution of four ¹⁴C benzoylphenyl ureas in last instar larvae of *Spodoptera littoralis* (Boisd.) and their excrements. *Med. Fac. Landbouww. Rijksuniv. Gent* **53**, 751-757.
- Evans, H.E. (1984). *Insect Biology: A Textbook of Entomology*. Addison-Wesley Publishing Company, San Francisco, CA, USA.
- Farnham, A.W., Murray, A.W.A., Sawicki, R.M., Denholm, I. and White, J.C. (1987). Characterization of the structure-activity relationship of *kdr* and 2 variants of *super-kdr* to pyrethroids in the housefly (*Musca domestica* L.). *Pest. Sci.* **19**, 209-220.

- Feyereisen, R. (1995). Molecular biology of insecticide resistance. *Toxicol. Lett.* **82/83**, 83-90.
- Feyereisen, R. (1999). Insect P450 enzymes. *Annu. Rev. Entomol.* **44**, 507-533.
- Field, L.M., Devonshire, A.L. and Forde, B.G. (1988). Molecular evidence that insecticide resistance in peach-potato aphids (*Myzus persicae* Sulz.) results from amplification of an esterase gene. *Biochem. J.* **251**, 309-312.
- Field, L.M. and Devonshire, A.L. (1998). Evidence that the E4 and FE4 esterase genes responsible for insecticide resistance in the aphid *Myzus persicae* (Sulzer) are part of a gene family. *Biochem. J.* **330**, 169-173.
- Forgash, A.J. (1984). History, evolution, and consequences of insecticide resistance. *Pestic. Biochem. Physiol.* **22**, 178-186.
- Fournier, D., Bride, J.M., Hoffmann, F. and Karch, F. (1992). Acetylcholinesterase. Two types of modifications confer resistance to insecticide. *J. Biol. Chem.* **267**, 14270-14274.
- Fournier, D. and Mutero, A. (1994). Modification of acetylcholinesterase as a mechanism of resistance to insecticides. *Comp. Biochem. Physiology C: Toxicol. Pharmacol.* **108**, 19-31.
- Gammon, D.W., Brown, M.A. and Casida, J.E. (1981). Two classes of pyrethroid action in the cockroach. *Pestic. Biochem. Physiol.* **15**, 181-191.
- Georghiou, G. and Lagunes-Tejeda, A. (1991). The Occurrence of Resistance to Pesticides in Arthropods: An Index of Cases reported through 1989. Food and Agriculture Organization of the United Nations, Rome.
- Glenn, D.C., Hoffmann, A.A. and McDonald, G. (1994). Resistance to pyrethroids in *Helicoverpa armigera* (Lepidoptera: Noctuidae) from corn: adult resistance, larval resistance, and fitness effects. *J. Econ. Entomol.* **87**, 1165-1171.
- Grant, D.F. and Hammock, B.D. (1992). Genetic and molecular evidence for a *trans*-acting regulatory locus controlling glutathione S-transferase-2 expression in *Aedes aegypti*. *Mol. Gen. Genet.* **234**, 169-176.
- Guedes, R.N.C., Zhu, K.Y., Kambhampati, S. and Dover, B.A. (1997). An altered acetylcholinesterase conferring negative cross-insensitivity to different insecticidal inhibitors in organophosphate-resistant lesser grain borer, *Rhyzopertha dominica*. *Pestic. Biochem. Physiol.* **58**, 55-62.
- Guerrero, F.D., Jamroz, R.C., Kammlah, D. and Kunz, S.E. (1997). Toxicological and molecular characterization of pyrethroid-resistant horn flies, *Haematobia irritans*: identification of *kdr* and *super-kdr* point mutations. *Insect Biochem. Molec. Biol.* **27**, 745-755.
- Gullan, P.J. and Cranston, P.S. (2005). *The insects: An outline of entomology*. Third Edition, Blackwell Publishing, Oxford, England.
- Gunning, R.V., Easton, C.S., Balfe, M.E. and Ferris, I.G. (1991). Pyrethroid resistance mechanisms in Australian *Helicoverpa armigera*. *Pestic. Sci.* **33**, 473-490.
- Gunning, R.V. and Easton, C.S. (1994). Endosulfan resistance in *Helicoverpa armigera* (Hübner) (Lepidoptera: Noctuidae) in Australia. *J. Aust. Entomol. Soc.* **33**, 9-12.
- Gunning, R.V., Devonshire, A.L. and Moores, G.D. (1995). Metabolism of esfenvalerate by pyrethroid-susceptible and -resistant Australian *Helicoverpa armigera* (Lepidoptera: Noctuidae). *Pestic. Biochem. Physiol.* **51**, 205-213.
- Gunning, R.V., Moores, G.D. and Devonshire, A.L. (1996a). Insensitive acetylcholinesterase and resistance to thiodicarb in Australian *Helicoverpa armigera* Hübner (Lepidoptera: Noctuidae). *Pestic. Biochem. Physiol.* **55**, 21-28.

- Gunning, R.V., Moores, G.D. and Devonshire, A.L. (1996b). Esterases and esfenvalerate resistance in Australian *Helicoverpa armigera* (Hübner) (Lepidoptera: Noctuidae). *Pestic. Biochem. Physiol.* **54**, 12-23.
- Gunning, R.V., Moores, G.D. and Devonshire, A.L. (1999). Esterase inhibitors synergise the toxicity of pyrethroids in Australian *Helicoverpa armigera* (Hübner) (Lepidoptera: Noctuidae). *Pestic. Biochem. Physiol.* **63**, 50-62.
- Gunning, R.V. and Moores, G.D. (2001). Insensitive acetylcholinesterase as sites for resistance to organophosphates and carbamates in insects: insensitive acetylcholinesterase confers resistance in Lepidoptera. In: *Biochemical Sites of Insecticide Action and Resistance*. (Ed. I. Ishaaya), Springer-Verlag, Berlin, Heidelberg, pp. 221-238.
- Gut, I.G. (2001). Automation in genotyping of single nucleotide polymorphisms. *Hum. Mutat.* **17**, 475-492.
- Habig, W.H., Pabst, M.J. and Jakoby, W.B. (1974). Glutathione S-transferases, the first step in mercapturic acid formation. *J. biol. Chem.* **249**, 7130-7139.
- Hall, T. (2007). Ecological effects assessment of flubendiamide. *Pflanzenschutz-Nachrichten Bayer* **60**, 167-182.
- Head, D.J., McCaffery, A.R. and Callaghan, A. (1998). Novel mutations in the *para*-homologous sodium channel gene associated with phenotypic expression of nerve insensitivity resistance to pyrethroids in Heliothine lepidoptera. *Insect Molec. Biol.* **7**, 191-196.
- Hemingway, J., Hawkes, N., Prapanthadara, L., Indrananda J. and Ranson, H. (1999). The role of gene splicing, gene amplification and regulation in mosquito insecticide resistance. In: *Insecticide Resistance: From Mechanisms to Management*. (Eds. I. Denholm, J.A. Pickett and A.L. Devonshire), CABI Publishing London, pp. 19-23.
- Hemingway, J. (2000). The molecular basis of two contrasting metabolic mechanisms of insecticide resistance. *Insect Biochem. Molec. Biol.* **30**, 1009-1015.
- Hirooka, T., Schneider, J., Masters, R. and Büschbell, T. (2007). Introduction. *Pflanzenschutz-Nachrichten Bayer* **60**, 101-104.
- Hirooka, T., Nishimatsu, T., Kodama, H., Reckmann, U. and Nauen, R. (2007). The biological profile of flubendiamide, a new benzenedicarboxamide insecticide. *Pflanzenschutz-Nachrichten Bayer* **60**, 183-202.
- Hodgson, E. (1983). The significance of cytochrome P-450 in insects. *Insect Biochem.* **13**, 237-246.
- Hoffmann, G.M., Nienhaus, F., Poehling, H.-M., Schönbeck, F., Weltzien, H.C. and Wilbert, H. (1994). Tierische Schädlinge und ihre natürlichen Gegenspieler. In: *Lehrbuch der Phytomedizin*. 3. Auflage, Blackwell Wissenschafts-Verlag, Berlin, Germany, pp. 171-175.
- Huang, H.S., Hu, N.T., Yao, Y.E., Wu, C.Y., Chiang, S.W. and Sun, C.N. (1998). Molecular cloning and heterologous expression of a glutathione S-transferase involved in insecticide resistance from the diamondback moth, *Plutella xylostella*. *Insect Biochem. Molec. Biol.* **28**, 651-668.
- Ibrahim, S.A and Ottea, J.A. (1995). Biochemical and toxicological studies with laboratory and field populations of *Heliothis virescens* (F.). *Pestic. Biochem. Physiol.* **53**, 116-128.
- Ingles, P.J., Adams, P.M., Knipple, D.C. and Soderlund, D.M. (1996). Characterization of voltage-sensitive sodium channel gene coding sequences from insecticide-susceptible and knockdown-resistant house fly strains. *Insect Biochem. Molec. Biol.* **26**, 319-326.
- Ishaaya, I. and Klein, M. (1990). Response of susceptible laboratory and resistant field strains of *Spodoptera littoralis* (Lepidoptera: Noctuidae) to teflubenzuron. *J. Econ. Entomol.* **83**, 59-62.

- Ishaaya, I. (1993). Insect detoxifying enzymes: their importance in pesticide synergism and resistance. *Arch. Insect Biochem. Physiol.* **22**, 263-276.
- Ishaaya, I. (2001). Biochemical processes related to insecticide action: an overview. In: *Biochemical Sites of Insecticide Action and Resistance*. (Ed. I. Ishaaya), Springer-Verlag, Berlin, Heidelberg, pp. 1-16.
- Jansson, R.K. and Dybas, R.A. (1998). Avermectins: Biochemical mode of action, biological efficacy and agricultural importance. In: *Insecticides with Novel Modes of Action, Mechanism and Application*. (Eds. I. Ishaaya and D. Degheele), Springer-Verlag, Berlin, Heidelberg, pp. 152-170.
- Jefferies, P.R., Yu, P. and Casida, J.E. (1997). Structural modifications increase the insecticidal activity of ryanodine. *Pestic. Sci.* **51**, 33-38.
- Kanga, L.H.B., Pree, D.J., Van Lier, J.L. and Whitty, K.J. (1997). Mechanisms of resistance to organophosphorus and carbamate insecticides in oriental fruit moth populations (*Grapholita Molesta* Busck). *Pestic. Biochem. Physiol.* **59**, 11-23.
- Karunaratne, S.H.P.P., Vaughan, A., Paton, M.G. and Hemingway, J. (1998). Amplification of a serine esterase gene is involved in insecticide resistance in Sri Lankan *Culex tritaeniorhynchus*. *Insect Molec. Biol.* **7**, 307-315.
- Kennaugh, L., Pearce, D., Daly, J.C. and Hobbs, A.A. (1993). Piperonyl butoxide synergizable resistance to permethrin in *Helicoverpa armigera* which is not due to increased detoxification by cytochrome P450. *Pestic. Biochem. Physiol.* **45**, 234-241.
- Kerns, D.L., Palumbo, J.C. and Tellez, T. (1998). Resistance of field strains of beet armyworm (Lepidoptera: Noctuidae) from Arizona and California to carbamate insecticides. *J. Econ. Entomol.* **91**, 1038-1043.
- Kranthi, K.R., Jadhav, D., Wanjari, R., Kranthi, S. and Russell, D. (2001). Pyrethroid resistance and mechanisms of resistance in field strains of *Helicoverpa armigera* (Lepidoptera: Noctuidae). *J. Econ. Entomol.* **94**, 253-263.
- Kranthi, K.R., Jadhav, D.R., Kranthi, S., Wanjari, R.R., Ali, S.S. and Russell, D.A. (2002). Insecticide resistance in five major insect pests of cotton in India. *Crop Protect.* **21**, 449-460.
- Kristensen, M. and Jespersen, J.B. (2003). Larvicide resistance in *Musca domestica* (Diptera: Muscidae) populations in Denmark and establishment of resistant laboratory strains. *J. Econ. Entomol.* **96**, 1300-1306.
- Lagadic, L., Leicht, W., Ford, M.G., Salt, D.W. and Greenwood, R. (1993). Pharmacokinetics of cyfluthrin in *Spodoptera littoralis* (Boisd.). I. *In vivo* distribution and elimination of [¹⁴C]cyfluthrin in susceptible and pyrethroid-resistant larvae. *Pestic. Biochem. Physiol.* **45**, 105-115.
- Lee, S.H., Dunn, J.B., Clark, J.M. and Soderlund, D.M. (1999). Molecular analysis of *kdr*-like resistance in a permethrin-resistant strain of Colorado potato beetle. *Pestic. Biochem. Physiol.* **63**, 63-75.
- Little, E.J., McCaffery, A.R., Walker, C.H. and Parker, T. (1989). Evidence for an enhanced metabolism of cypermethrin by a monooxygenase in a pyrethroid-resistant strain of the tobacco budworm (*Heliothis virescens* F.). *Pestic. Biochem. Physiol.* **34**, 58-68.
- Loughney, K., Kreber, R. and Ganetzky, B. (1989). Molecular analysis of the *para* locus, a sodium channel in *Drosophila*. *Cell* **58**, 1143-1154.
- Martin, S.H., Elzen, G.W., Graves, J.B., Micinski, S., Leonard, B.R. and Burris, E. (1995). Toxicological responses of tobacco budworm (Lepidoptera: Noctuidae) from Louisiana, Mississippi, and Texas to selected insecticides. *J. Econ. Entomol.* **88**, 505-511.

- Martin, T., Ochou, G.O., Hala-N'Klo, F., Vassal, J.-M. and Vaissayre, M. (2000). Pyrethroid resistance in cotton bollworm, *Helicoverpa armigera* (Hübner), in West Africa. *Pest Manag. Sci.* **56**, 549-554.
- Martinez-Torres, D., Devonshire, A.L. and Williamson, M.S. (1997). Molecular studies of knockdown resistance to pyrethroids: cloning of domain II sodium channel gene sequences from insects. *Pestic. Sci.* **51**, 265-270.
- Martinez-Torres, D., Chevillon, C.A., Brun-Barale, A., Bergé, J.B., Pasteur, N. and Pauron, D. (1999). Voltage-dependent Na⁺ channels in pyrethroid-resistant *Culex pipiens* L mosquitoes. *Pestic. Sci.* **55**, 1012-1020.
- Mascarenhas, V.J., Graves, J.B., Leonard, B.R. and Burris, E. (1998). Susceptible of field populations of beet armyworm (Lepidoptera: Noctuidae) to commercial and experimental insecticides. *J. Econ. Entomol.* **91**, 827-833.
- McCaffery A. and Nauen R. (2006). The Insecticide Resistance Action Committee (IRAC): Public responsibility and enlightened industrial self-interest. *Outlooks Pest Manag.* **17**, 11-14.
- McCaffery, A.R. (1999). Resistance to insecticides in heliothine Lepidoptera: a global view. In: *Insecticide Resistance: From Mechanisms to Management*. (Eds. I. Denholm, J.A. Pickett and A.L. Devonshire), CABI Publishing London, pp. 59-74.
- Moore, G.D., Gao, X., Denholm, I. and Devonshire, A.L. (1996). Characterization of insensitive acetylcholinesterase in insecticide-resistant cotton aphids, *Aphids gossypii* Glover (Homoptera: Aphididae). *Pestic. Biochem. Physiol.* **56**, 102-110.
- Motoyama, N. and Dautermann, W.C. (1975). Interstrain comparison of glutathione-dependent reactions in susceptible and resistant houseflies. *Pestic. Biochem. Physiol.* **5**, 489-495.
- Mouches, C., Pasteur, N., Berge, J.B., Hyrien, O., Raymond, M., DeSaint Vincent, B.R., De Silvestri, M. and Georgiou, G.P. (1986). Amplification of an esterase gene is responsible for insecticide resistance in a Californian *Culex* mosquito. *Science* **233**, 778-780.
- Moulton, J.K., Pepper, D.A. and Dennehy, T.J. (2000). Beet armyworm (*Spodoptera exigua*) resistance to spinosad. *Pest Manag. Sci.* **56**, 842-828.
- Murugesan, K. and Dhingra, S. (1995). Variability in resistance pattern of various groups of insecticides evaluated against *Spodoptera litura* (Fabricius) during a period spanning over three decades. *J. ent. Res.* **19**, 313-319.
- Mutero, A., Pralavorio, M., Bride, J.M. and Fournier, D. (1994). Resistance-associated point mutations in insecticide-insensitive acetylcholinesterase. *Proc. Natl. Acad. Sci. USA* **91**, 5922-5926.
- Narahashi, T. (2000). Neuroreceptors and Ion Channels as the Basis for Drug Action: Past, Present, and Future. *J. Pharmacol. Exp. Ther.* **294**, 1-26.
- Natsuhara, K., Shimada, K., Tanaka, T. and Miyata, T. (2004). Phenobarbital induction of permethrin detoxification and phenobarbital metabolism in susceptible and resistant strains of the beet armyworm *Spodoptera exigua* (Hübner). *Pestic. Biochem. Physiol.* **79**, 33-41.
- Nauen, R. (2002). Aphid toxicology and plant systemic properties of an insecticidal tetramic acid derivate. *Dissertation - University of Portsmouth, School of Biological Sciences*.
- Nauen, R. and Bretschneider, T. (2002). New modes of action of insecticides. *Pestic. Outlook* **13**, 241-245.
- Nauen, R. and Stumpf, N. (2002). Fluorometric microplate assay to measure glutathione S-transferase activity in insects and mites using monochlorobimane. *Anal. Biochem.* **303**, 194-198.

- Nauen, R. (2006). Insecticide mode of action: return of the ryanodine receptor. *Pest Manag. Sci.* **62**, 690-692.
- Nishimatsu, T., Kodama, H., Kuriyama, K., Tohnishi, M., Ebbinghaus, D. and Schneider, J. (2005). A novel insecticide agent, flubendiamide, for controlling lepidopterous insect pests. *International Conference on Pesticides 2005*, Kuala Lumpur, Malaysia, Book of Abstracts.
- Noppun, V., Saito, T. and Miyata, T. (1989). Cuticular penetration of S-fenvalerate in fenvalerate-resistant and susceptible strains of the diamondback moth, *Plutella xylostella* (L.). *Pestic. Biochem. Physiol.* **33**, 83-87.
- Nordfors, L., Jansson, M., Sandberg, G., Lavebratt, C., Sengul, S., Schalling, M. and Arner, P. (2002). Large-scale genotyping of single nucleotide polymorphisms by pyrosequencingTM and validation against the 5' nuclease (TaqMan[®]) assay. *Hum. Mutat.* **19**, 395-401.
- Nordström, T., Ronaghi, M., Forsberg, L., de Faire, U., Morgenstern, R. and Nyrén, P. (2000). Direct analysis of single-nucleotide polymorphism on double-stranded DNA by pyrosequencing. *Biotechnol. Appl. Biochem.* **31**, 107-112.
- Oppenoorth, F.J (1985). Biochemistry and genetics of insecticide resistance In: *Comprehensive insect physiology, biochemistry and pharmacology* (Vol. **12** Eds. G.A. Kerkut and L.I. Gilbert), Pergamon, Oxford, U.K., pp. 731-773.
- Ottea, J.A., Ibrahim, S.A., Younis, A.M., Young, R.J., Leonard, B.R. and McCaffery, A.R. (1995). Biochemical and physiological mechanisms of pyrethroid resistance in *Heliothis virescens* (F.). *Pestic. Biochem. Physiol.* **51**, 117-128.
- Ozoe, Y. and Akamatsu, M. (2001). Non-competitive GABA antagonists: probing the mechanisms of their selectivity for insect *versus* mammalian receptors. *Pest Manag. Sci.* **57**, 923-931.
- Palli, S.R. and Retnakaran, A. (2001). Ecdysteroid and juvenile hormone receptors: properties and importance in developing novel insecticides. In: *Biochemical Sites of Insecticide Action and Resistance*. (Ed. I. Ishaaya), Springer-Verlag, Berlin, Heidelberg, pp. 107-132.
- Park, Y., Taylor, M.F.J. and Feyereisen, R. (1999). Voltage-gated sodium channel genes *hscp* and *hDSC1* of *Heliothis virescens* F. genomic organization. *Insect Molec. Biol.* **8**, 161-170.
- Pasteur, N. and Georghiou, G.P. (1989). Improved filter paper test for detecting and quantifying in organophosphate-resistant mosquitoes (Diptera: Culicidae). *J. Econ. Entomol.* **82**, 347-353.
- Pérez, C.J., Alvarado, P., Narváez, C., Miranda, F., Hernández, L., Vanegas, H., Hruska, A. and Shelton, A.M. (2000). Assessment of insecticide resistance in five insect pests attacking field and vegetable crops in Nicaragua. *J. Econ. Entomol.* **93**, 1779-1787.
- Qiu, X., Li, W., Tian, Y. and Leng, X. (2003). Cytochrome P450 monoxygenases in the cotton bollworm (Lepidoptera: Noctuidae): tissue difference and induction. *J. Econ. Entomol.* **96**, 1283-1289.
- Ranasinghe, C., Headlam, M., Hobbs, A.A. (1997). Induction of the mRNA for CYP6B2, a pyrethroid inducible cytochrome P450, in *Helicoverpa amigera* (Hubner) by dietary monoterpenes. *Arch. Insect. Biochem. Physiol.* **34**, 99-109.
- Ranson, H., Prapanthadara, L., and Hemingway, J. (1997). Cloning and characterization of two glutathione S-transferases from a DDT-resistant strain of *Anopheles gambiae*. *Biochem. J.* **324**, 97-102.

- Ranson, H., Jensen, B., Vulule, J.M., Wang, X., Hemingway, J. and Collins, F.H. (2000). Identification of a point mutation in the voltage-gated sodium channel gene of Kenyan *Anopheles gambiae* associated with resistance to DDT and pyrethroids. *Insect Molec. Biol.* **9**, 491-497.
- Rauch, N. and Nauen, R. (2003). Identification of biochemical markers linked to neonicotinoid cross resistance in *Bemisia tabaci* (Hemiptera: Aleyrodidae). *Arch. Insect Biochem. Physiol.* **54**, 165-176.
- Rauch, N. and Nauen, R. (2004). Characterization and molecular cloning of a glutathione S-transferase from the whitefly *Bemisia tabaci* (Hemiptera: Aleyrodidae). *Insect Biochem. Molec. Biol.* **34**, 321-329.
- Raymond, M., Fournier, D., Bride, J.-M., Cuany, A., Berge, J., Magnin, M. and Pasteur, N. (1986). Identification of resistance mechanisms in *Culex pipiens* (Diptera: Culicidae) from southern France: insensitive acetylcholinesterase and detoxifying oxidases. *J. Econ. Entomol.* **79**, 1452-1458.
- Riskallah, M.R. (1983). Esterases and resistance to synthetic pyrethroids in the Egyptian cotton leafworm. *Pestic. Biochem. Physiol.* **19**, 184-189.
- Rose, R.L., Barbhuiya, L., Roe, R.M., Rock, G.C. and Hodgson, E. (1995). Cytochrome P450-associated insecticide resistance and the development of biochemical diagnostic assays in *Heliothis virescens*. *Pestic. Biochem. Physiol.* **51**, 178-191.
- Rossiter, L.C., Gunning, R.V. and Rose, H.A. (2001). The use of polyacrylamide gel electrophoresis for the investigation and detection of fenitrothion and chlorpyrifos-methyl resistance in *Oryzaephilus surinamensis* (Coleoptera: Silvanidae). *Pestic. Biochem. Physiol.* **69**, 27-34.
- Russell, R.J., Claudianos, C., Campbell, P.M., Horne, I., Sutherland, T.D. and Oakeshott, J.G. (2004). Two major classes of target site insensitivity mutations confer resistance to organophosphate and carbamate insecticides. *Pestic. Biochem. Physiol.* **79**, 84-93.
- Sauphanor, B. and Bouvier, J.C. (1995). Cross-resistance between benzoylureas and benzoylhydrazines in the codling moth, *Cydia pomonella* L. *Pestic. Sci.* **45**, 369-375.
- Sauphanor, B., Cuany, A., Bouvier, J.C., Brosse, V., Amichot, M. and Bergé, J.-B. (1997). Mechanism of resistance to deltamethrin in *Cydia pomonella* (L.) (Lepidoptera: Tortricidae). *Pestic. Biochem. Physiol.* **58**, 109-117.
- Schuler, T.H., Martinez-Torres, D., Thompson, A.J., Denholm, I., Devonshire, A.L., Duce, I.R. and Williamson, M.S. (1998). Toxicological, electrophysiological, and molecular characterisation of knockdown resistance to pyrethroid insecticides in the diamondback moth, *Plutella xylostella* (L.). *Pestic. Biochem. Physiol.* **59**, 169-182.
- Scott, J.G. (1999). Cytochromes P450 and insecticide resistance. *Insect. Biochem. Molec. Biol.* **29**, 757-777.
- Scott, J.G. (2001). Cytochrome P450 monooxygenases and insecticide resistance: lessons from CYP6D1. In: *Biochemical Sites of Insecticide Action and Resistance*. (Ed. I. Ishaaya), Springer-Verlag, Berlin, Heidelberg, pp. 255-267.
- Siegfried, B.D. and Scharf, M.E. (2001). Mechanisms of organophosphate resistance in insects. In: *Biochemical Sites of Insecticide Action and Resistance*. (Ed. I. Ishaaya), Springer-Verlag, Berlin, Heidelberg, pp. 269-321.
- Smagghe, G. and Tirry, L. (2001). Insect midgut as a site for insecticide detoxification and resistance. In: *Biochemical Sites of Insecticide Action and Resistance*. (Ed. I. Ishaaya), Springer-Verlag, Berlin, Heidelberg, pp. 293-321.
- Smagghe, G., Pineda, S., Carton, B., Del Estal, P., Budia, F. and Viñuela, E. (2003). Toxicity and kinetics of methoxyfenozide in greenhouse-selected *Spodoptera exigua* (Lepidoptera: Noctuidae). *Pest Manag. Sci.* **59**, 1203-1209.

- Small, G.J. and Hemingway, J. (2000). Molecular characterisation of the amplified carboxylesterase gene associated with organophosphorus insecticide resistance in the brown planthopper *Nilaparvata lugens*. *Insect Molec. Biol.* **9**, 647-653.
- Smissaert, H.R. (1964). Cholinesterase inhibition in spider mites susceptible and resistant to organophosphates. *Science* **143**, 129-131.
- Snyder, M.J., Stevens, J.L., Andersen, J.F., Feyereisen, R. (1995). Expression of cytochrome P450 genes of the CYP4 family in midgut and fat body of the tobacco hornworm, *Manduca sexta*. *Arch. Biochem. Biophys.* **321**, 13-20.
- Soderlund, D.M. (1997). Molecular mechanisms of insecticide resistance. In: *Molecular mechanisms of resistance to agrochemicals*. (Vol. 13 Ed. V. Sjut), Spinger, Heidelberg New York, pp. 21-56.
- Stumpf, N. and Nauen, R. (2001). Cross-resistance, inheritance, and biochemistry of mitochondrial electron transport inhibitor-acaricide resistance in *Tetranychus urticae* (Acari: Tetranychidae). *J. Econ. Entomol.* **94**, 1577-1583.
- Stumpf, N. and Nauen, R. (2002). Biochemical markers linked to abamectin resistance in *Tetranychus urticae* (Acari: Tetranychidae). *Pestic. Biochem. Physiol.* **72**, 111-121.
- Sun, Y.-P. and Johnson, E.R. (1972). Quasi-synergism and penetration of insecticides. *J. Econ. Entomol.* **65**, 349-353.
- Sun, C-N., Huang, S-Y., Hu, N-T. and Chung, W-Y. (2001). Glutathione S-transferases and insect resistance to insecticides. In: *Biochemical Sites of Insecticide Action and Resistance*. (Ed. I. Ishaaya), Springer-Verlag, Berlin, Heidelberg, pp. 239-254.
- Thompson, G. and Hutchins, S. (1999). Spinosad. *Pestic. Outlook* **4**, 78-81.
- Tohnishi, M., Nakao, H., Furuya, T., Seo, A., Kodama, H., Tsubata, K., Fujioka, S., Kodama, H., Hirooka, T. and Nishimatsu, T. (2005). Flubendiamide, a novel class insecticide highly active against lepidopterous insect pests. *J. Pestic. Sci.* **30**, 354-360.
- Torres-Vila, L.M., Rodríguez-Molina, M.C., Lacasa-Plasencia, A., Biella-Lino, P. and Rodríguez-del-Rincón, Á. (2002). Pyrethroid resistance of *Helicoverpa armigera* in Spain: current status and agroecological perspective. *Agr. Ecosyst. Environ.* **93**, 55-66.
- Treacy, M., Miller, T., Black, B., Gard, I., Hunt, D. and Hollingworth, R.M. (1994). Uncoupling activity and pesticidal properties of pyrroles. *Biochem. Soc. Trans.* **22**, 244-247.
- Tsubata, K., Tohnishi, M., Kodama, H. and Seo, A. (2007). Chemistry of flubendiamide – discovery, synthesis and X-ray structure. *Pflanzenschutz-Nachrichten Bayer* **60**, 105-116.
- Vais, H., Williamson, M.S., Devonshire, A.L. and Usherwood, P.N.R. (2001). The molecular interactions of pyrethroid insecticides with insect and mammalian sodium channels. *Pest Manag. Sci.* **57**, 877-888.
- Van Laecke, K. and Degheele, D. (1991a). Detoxification of diflubenzuron and teflubenzuron in the larvae of beet armyworm (*Spodoptera exigua*) (Lepidoptera: Noctuidae). *Pestic. Biochem. Physiol.* **40**, 181-190.
- Van Laecke, K. and Degheele, D. (1991b). Synergism of diflubenzuron and teflubenzuron in larvae of beet armyworm (Lepidoptera: Noctuidae). *J. Econ. Entomol.* **84**, 785-789.
- Van Laecke, K., Smagghe, G. and Degheele, D. (1995). Detoxifying enzymes in greenhouse and laboratory strain of beet armyworm (Lepidoptera: Noctuidae). *J. Econ. Entomol.* **88**, 777-781.
- Villatte, F., Augé, D., Touton, P., Delorme, R. and Fournier, D. (1999). Negative cross-insensitivity in insecticide-resistant cotton aphid *Aphis gossypii* Glover. *Pestic. Biochem. Physiol.* **65**, 55-61.

- Wang, R., Huang, Z.Y. and Dong, K. (2003). Molecular characterization of an arachnid sodium channel gene from the varroa mite (*Varroa destructor*). *Insect Biochem. Molec. Biol.* **33**, 733-739.
- Werck-Reichhart, D. and Feyereisen, R. (2000). Cytochrome P450: a success story. *Genome Biol.* **1**, 1-9.
- Williamson, M.S., Denholm, I., Bell, C.A., and Devonshire, A.L. (1993). Knockdown resistance (*kdr*) to DDT and pyrethroid insecticides maps to a sodium channel gene locus in the housefly (*Musca domestica*). *Molec. Gen. Genet.* **240**, 17-22.
- Williamson, M.S., Martinez-Torres, D., Hick, C.A. and Devonshire, A.L. (1996). Identification of mutations in the housefly *para*-type sodium channel gene associated with knockdown resistance (*kdr*) to pyrethroid insecticides. *Molec. Gen. Genet.* **252**, 51-60.
- Wing, K.D., Schnee, M.E., Sacher, M., and Connair, M. (1998). A novel oxadiazine insecticide is bioactivated in lepidopteran larvae. *Arch. Insect Biochem. Physiol.* **37**, 91-103.
- Wing, K.D., Sacher, M., Kagaya, Y., Tsurubuchi, Y., Mulderig, L., Connair, M. and Schnee, M.E. (2000). Bioactivation and mode of action of the oxadiazine indoxacarb in insects. *Crop Protect.* **19**, 537-545.
- World Health Organization (1957). 22nd Report by the Expert Committee on Insecticides. WHO Tech. Rep. Ser. 7th Rep., 125pp.
- Wu, G., Jiang, S. and Miyata, T. (2004). Seasonal changes of methamidophos susceptibility and biochemical properties in *Plutella xylostella* (Lepidoptera: Yponomeutidae) and its parasitoid *Cotesia plutellae* (Hymenoptera: Braconidae). *J. Econ. Entomol.* **97**, 1689-1698.
- Yang, Y., Wu, Y., Chen, S., Devine, G.J., Denholm, I., Jewess, P. and Moores, G.D. (2004). The involvement of microsomal oxidases in pyrethroid resistance in *Helicoverpa armigera* from Asia. *Insect Biochem. Molec. Biol.* **34**, 763-773.
- Yoo, J.-K., Lee, S.-W., Ahn, Y.-J., Nagata, T. and Shono, T. (2002). Altered acetylcholinesterase as a resistance mechanism in the brown planthopper (Homoptera: Delphacidae), *Nilaparvata lugens* Stal. *Appl. Entomol. Zool.* **37**, 37-41.
- Young, S.J., Gunning, R.V. and Moores, G.D. (2005). The effect of piperonyl butoxide on pyrethroid-resistance-associated esterases in *Helicoverpa armigera* (Hübner) (Lepidoptera: Noctuidae). *Pest Manag. Sci.* **61**, 397-401.
- Yu, S.J. (1991). Insecticide resistance in the fall armyworm, *Spodoptera frugiperda* (J.E. Smith). *Pestic. Biochem. Physiol.* **39**, 84-91.
- Yu, S.J. (1992). Detection and biochemical characterization of insecticide resistance in fall armyworm (Lepidoptera: Noctuidae). *J. Econ. Entomol.* **85**, 675-682.
- Yu, S.J. and Huang, S.W. (2000). Purification and characterization of glutathione S-transferases from the German cockroach, *Blattella germanica* (L.). *Pestic. Biochem. Physiol.* **67**, 36-45.
- Yu, S.J. (2002). Biochemical characteristics of microsomal and cytosolic glutathione S-transferases in larvae of the fall armyworm, *Spodoptera frugiperda* (Smith). *Pestic. Biochem. Physiol.* **72**, 100-110.
- Yu, S.J., Nguyen, S.N. and Abo-Elghar, G.E. (2003). Biochemical characteristics of insecticide resistance in the fall armyworm, *Spodoptera frugiperda* (J.E. Smith). *Pestic. Biochem. Physiol.* **77**, 1-11.

-
- Zhao, G., Rose, R.L., Hodgson, E. and Roe, R.M. (1996). Biochemical mechanisms and diagnostic microassays for pyrethroid, carbamate, and organophosphate insecticide resistance/cross-resistance in the tobacco budworm, *Heliothis virescens*. *Pestic. Biochem. Physiol.* **56**, 183-195.
- Zhu, K.Y. and Clark, M. (1995). Comparisons of kinetic properties of acetylcholinesterase purified from azinphosmethyl-susceptible and resistant strains of Colorado potato beetle. *Pestic. Biochem. Physiol.* **51**, 57-67.
- Zlotkin, E. (2001). Insecticides affecting voltage-gated ion channel. In: *Biochemical Sites of Insecticide Action and Resistance*. (Ed. I. Ishaaya), Springer-Verlag, Berlin, Heidelberg, pp. 43-76.

9 APPENDICES

APPENDIX A

Page 57, Table 16

Worldwide monitoring with flubendiamide: detailed information about location, sampler and treatment history

Species	Country	No.	Location / Field area	Sampler	Treatment History	Comment	
<i>S. exigua</i>	Spain	A	Almería / La Mojonera	Dolores Alcázar	Nomolt (17/05/04), Mimic (04/06/04)	-	
		B	Almería / El Ejido	Dolores Alcázar	Match, Delfin, Alfa-cypermethrin	-	
		C	Almería / Adra	Dolores Alcázar	Pyrethroids	-	
		D	Almería / Dalías (863)	Dolores Alcázar	Bt ^a , Soap	IPM crop	
		E	Almería / Dalías (848)	Dolores Alcázar	Bt ^a	IPM crop	
		F	Nijar (Almería) / Barranquete	Dolores Alcázar	Lannate	-	
		G	Nijar (Almería) / Ctra. San José	Dolores Alcázar	Lannate, Decis , Bt ^a	-	
		H	Torre Pacheco (Murcia) / Torre Pacheco	Angel Ruiz	Bt ^a + Decis, Spinosad, Chlorpyrifos + Decis	-	
	Thailand	A	Bangbuathong district Nontaburi Province	Sittichai Palleekul	Success 120 SC (180g a.i./ha), Rampage 100 SC (112g a.i./ha)	Multi-resistance (OP ^b , Pyrethroids, IGR ^c)	
	Mexico	A	Silao / Guanajuato (5 hectares)	Oscar Liedo Granillo	Chlorpyrifos (foliar)	-	
	Turkey	A	Adana region Karatas / Karatas Bebeli Village	Mehmet Simsek	No chemical applied before	Lambda-cyhalothrin and Cypermethrin known less efficacy and malathion known resistance	
	<i>H. armigera</i>	Spain	A	Puebla del Río (Sevilla) / Finca 'La Compañía'	Sabino Viejo	Endosulfan + Methomyl	-
			B	El Palmar de Troya (Sevilla) / Finca 'Las Peñuelas'	José María Bidegain	Endosulfan + Methomyl	-
Turkey		A	Yüregir / Dedeler Village	Mehmet Simsek	No chemical applied before	Beta-Cyfluthrin, Lambda-cyhalothrin and Cypermethrin known less efficacy	
Australia		A	CSIRO	Louise Rossiter	Susceptible strain	CSIRO = Commonwealth Scientific and Industrial Research Organisation	
		B	CSIRO	Louise Rossiter	Fenvalerate		
		C	CSIRO	Louise Rossiter	Bifenthrin		
		D	CSIRO	Louise Rossiter	Methomyl		

^a *Bacillus thuringiensis*, ^b Organophosphates, ^c Insect growth regulators

APPENDIX B

Page 34, Table 7

Radiochemical data sheets of [^{14}C]-radiolabelled compounds NNI-0001 (flubendiamide), deltamethrin and triflumuron

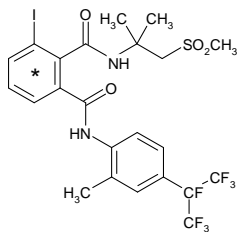
Substance	[phthalic acid ring-UL- ^{14}C] NNI-0001
	Total activity : 370 KBq (10 μCi) Specific activity : 4.3 MBq (116.1 μCi)/mg Form : solid, dried in vacuo * : position of label
Radiochemical purity	: 97.7 %
Method	: HPLC, radioactivity-detector
Column	: Lichrospher 60 RP-Select B [®] , 5 μm , 125 x 4 mm
Flow rate	: 1.5 ml/min
Eluent	: A = 0.2 % phosphoric acid, B = acetonitrile
Gradient	: 5 min 0 % B, at 35 min 100 % B, at 40 min 100 % B
Radiochemical purity	: 97.8 %
Method	: TLC, scan
Plate	: silica gel Merck 60 F 254 [®]
Eluent	: dichloromethane + ethyl acetate = 1 + 1 (v + v)
Chemical purity	: > 98 %
Method	: HPLC, UV-detector, 210 nm conditions as above

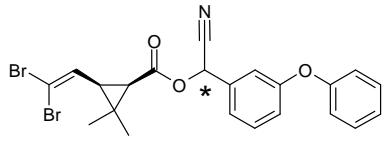
Substance	[benzyl- ¹⁴ C] Deltamethrin
	Total activity : 370 KBq (10 µCi) Specific activity : 4.24 MBq (114.5 µCi)/mg Form : solution in 380µl ethyl acetate * : position of label
	Radiochemical purity : 97.6 % Method : HPLC, radioactivity-detector Column : Lichrospher 60 RP-Select B [®] , 5 µm, 125 x 4 mm Flow rate : 1.5 ml/min Eluent : A = 0.2 % phosphoric acid, B = acetonitrile Gradient : 5 min 0 % B, at 35 min 100 % B, at 40 min 100% B
Radiochemical purity : > 98 % Method : TLC, scan Plate : silica gel Merck 60 F 254 [®] Eluent : toluene	
Chemical purity : > 98 % Method : HPLC, UV-detector, 210 nm conditions as above	
Plate : silica gel Merck 60 F 254 [®] Eluent : chloroform + methanol = 100 + 1 (v + v)	
Chemical purity : > 98 % Method : HPLC, UV-detector, 210 nm conditions as above	
Diastereomeric purity : > 98 % Method : HPLC, radioactivity-detector Column : Lichrospher Si 60 [®] , 5 µm, 250 x 4 mm Flow rate : 1.5 ml/min Oven temperature : + 40 °C Eluent : 30 min n-heptane + ethyl acetate = 97 + 3 (v + v)	

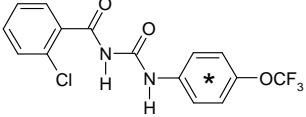
Substance	[phenoxy-UL- ¹⁴ C] Triflumuron
	Total activity : 370 KBq (10 μCi) Specific activity : 4.2 MBq (113.4 μCi)/mg Form : solid, dried in vacuo * : position of label
Radiochemical purity	: 97.7 %
Method	: HPLC, radioactivity-detector
Column	: Lichrospher 60 RP-Select B [®] , 5 μm, 125 x 4 mm
Flow rate	: 1.5 ml/min
Eluent	: A = 0.2 % phosphoric acid, B = acetonitrile
Gradient	: 5 min 0 % B, at 35 min 100 % B, at 40 min 100% B
Radiochemical purity	: > 98 %
Method	: TLC, scan
Plate	: silica gel Merck 60 F 254 [®]
Eluent	: chloroform + methanol = 100 + 1 (v + v)
Chemical purity	: > 98 %
Method	: HPLC, UV-detector, 210 nm conditions as above

APPENDIX C

Page 72, Figure 37 (mass homogenate)

Page 75, Figure 39 (affinity purification)

Data and equation of Figure 37 and 39; kinetic parameters of AChE

Enzyme source: mass homogenate and affinity purification

Strain	Mass homogenate		Affinity purification	
	SPOD-EX S	SPOD-EX E-98	SPOD-EX S	SPOD-EX E-98
$V_{\max} \pm SE$	1299 ± 144	2821 ± 67.6	1031 ± 100	11015 ± 639
$K_m \pm SE$	211 ± 87.9	140 ± 13.5	177 ± 47.2	75.5 ± 19.7
Degrees of freedom	4	4	4	4
r^2	0.9288	0.9963	0.9180	0.9696

 V_{\max} [mOD/min/mg protein]; K_m [μM]

APPENDIX D

Page 73, Table 18

Inhibition of AChE by pre-incubation with different inhibitors

Enzyme source: mass homogenate

Equation: Sigmoidal dose-response (variable slope)

$$Y = \text{Bottom} + (\text{Top} - \text{Bottom}) / (1 + 10^{((\text{LogEC}_{50} - X) * \text{HillSlope}))})$$

Compound / Chemical	Strain	Best-fit values			Goodness of Fit	
		Bottom	Top	Log EC ₅₀	Degrees of freedom	r ²
Carbofuran	SPOD-EX S	0.989	102.7	1.73	2	0.9997
	SPOD-EX E-98	1.039	104.0	-0.324	3	0.9995
Methomyl	SPOD-EX S	0.989	97.4	0.955	2	0.9996
	SPOD-EX E-98	-8.238	101.7	1.915	1	1.0
Thiodicarb	SPOD-EX S	-10.8	99.9	1.158	2	0.9988
	SPOD-EX E-98	-11.1	100.9	1.822	2	1.0
Methamidophos	SPOD-EX S	-1.259	110.9	2.194	2	0.9992
	SPOD-EX E-98	-20.9	103.7	3.186	2	0.9996
Paraoxon-ethyl	SPOD-EX S	-2.831	100.6	0.8366	2	0.9987
	SPOD-EX E-98	-2.728	100.5	0.9666	2	0.9990
Eserine	SPOD-EX S	-0.769	102.3	1.369	1	0.9997
	SPOD-EX E-98	0.857	103.3	-0.611	2	0.9996
BW284c51	SPOD-EX S	-0.634	110.1	-1.549	3	0.9997
	SPOD-EX E-98	-0.304	113.4	-1.722	3	0.9999

APPENDIX E

Page 76, Table 20

Inhibition of purified AChE by pre-incubation with different inhibitors

Equation: Sigmoidal dose-response (variable slope)

$$Y = \text{Bottom} + (\text{Top} - \text{Bottom}) / (1 + 10^{((\text{LogEC}_{50} - X) * \text{HillSlope}))})$$

Compound / Chemical	Strain	Best-fit values			Goodness of Fit	
		Bottom	Top	Log EC ₅₀	Degrees of freedom	r ²
Carbofuran	SPOD-EX S	0.090	106.0	1.634	0.9995	2
	SPOD-EX E-98	1.314	100.4	-0.417	1.0	2
Methomyl	SPOD-EX S	0.889	104.5	0.845	0.9990	2
	SPOD-EX E-98	2.127	103.8	1.735	0.9984	2
Thiodicarb	SPOD-EX S	-5.21	100.2	0.975	0.9997	2
	SPOD-EX E-98	1.421	106.8	1.594	0.9970	2

Acknowledgements

First of all I would like to express my gratitude to my external supervisors, Prof. Dr. Dr. Zebitz (*Institute of Phytomedicine, University of Hohenheim*), Prof. Dr. Schwack and Prof. Dr. Blaich (*University of Hohenheim*) for refereeing this thesis.

My special thanks are due to Dr. Ralf Nauen (*Bayer CropScience AG*) for supervision and introduction in the secrets of insecticide resistance research.

I would especially like to thank in this context to Dr. Natascha Rauch, Christiane Baltes and Brunhild Lawson for her introduction into laboratory and greenhouse work and her help given to me whenever necessary, and also to my trainees Sarah Twelker and Daniel Hein.

Great thank also to Dr. Jürgen Benting, Bettina Lüke and Tanja Ponge for her detailed introduction into Molecular Biology.

I also gratefully thank all the other colleagues in the laboratories at the *Department of Research Insecticides*, especially for providing with insect material.

Great thanks also go to Dr. Dirk Ebbinghaus (*Bayer CropScience AG*) and the staff at the field stations for carried out the worldwide monitoring.

Thanks to Dr. Christian Beier (*Bayer CropScience AG*) for synthesizing the radiolabelled deltamethrin, flubendiamide and triflumuron, and Dr. Heinz-Wilhelm Füsers (*Bayer CropScience AG*) to carried out the combustion studies.

Finally, I would like to thank my family and friends for their lifelong love. I especially owe much to my parents, my brother and my sister for their constant support and encouragement during my education in the past years.

Lebenslauf

Name:	Stefanie Konanz
Geburtsdatum:	01.02.1976
Geburtsort:	Pforzheim
Staatsangehörigkeit:	deutsch
Familienstand:	ledig
1982 - 1986	Grundschule, Bauschlott
1986 - 1991	Hauptschule, Neulingen
1991 - 1993	Zweijährige Berufsfachschule, Bretten
1993 - 1994	Soziales Jahr, Gemeindekindergarten Bauschlott
1994 - 1997	Berufliches Gymnasium, Ettlingen Abschluss: Allgemeine Hochschulreife
1997 - 2002	Studium der Agrarbiologie, Universität Hohenheim Abschluss: Diplom
7/1999 - 10/1999	Praktikum Südwestdeutsche Saatzucht, Rastatt
8/2000 - 10/2000	Praktikum Basf AG, Limburgerhof
9/2001 - 12/2001	Praktikum Bayer AG, Monheim
12/2001 - 5/2002	Diplomandin: Bayer AG, Monheim
7/2002 - 6/2005	Doktorandin: Bayer CropScience AG, Research Insecticides, Monheim Abteilung: Insect Toxicology and Resistance
6/2005 - 12/2006	arbeitssuchend
1/2007 - 12/2007	Wissenschaftliche Mitarbeiterin im Department of Entomology and Neuroscience Program, Michigan State University, USA
Seit 1/2008	arbeitssuchend