

2013

Trinity Restoration Inc. Theater Design

Arnold Robinson

Community Partnerships Center, cpc@rwu.edu

Follow this and additional works at: http://docs.rwu.edu/cpc_aud



Part of the [Urban, Community and Regional Planning Commons](#)

Recommended Citation

Robinson, Arnold, "Trinity Restoration Inc. Theater Design" (2013). *Architecture and Urban Design*. Paper 11.
http://docs.rwu.edu/cpc_aud/11

This Document is brought to you for free and open access by the Community Partnerships Center at DOCS@RWU. It has been accepted for inclusion in Architecture and Urban Design by an authorized administrator of DOCS@RWU. For more information, please contact [mwu@rwu.edu](mailto:rwu@rwu.edu).

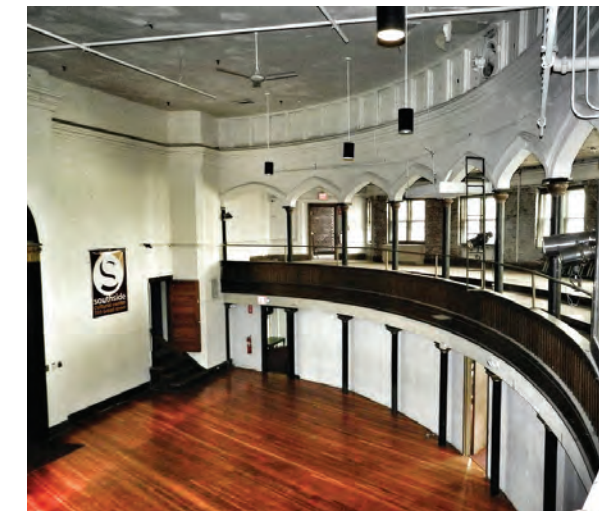
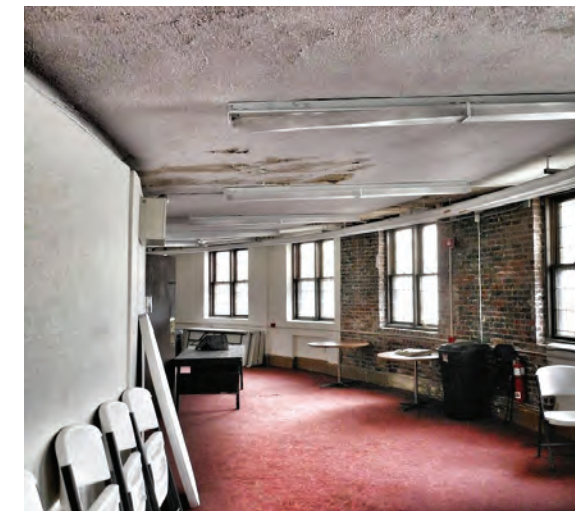

Trinity Restoration Inc. Theater Design

393 Broad Street | Providence | RI
Community Partner: Trinity Restoration Inc.

The RWU Community Partnerships Center

The Roger Williams University (RWU) Community Partnerships Center (CPC) provides project-based assistance to non-profit organizations, government agencies and low- and moderate-income communities in Rhode Island and Southeastern Massachusetts. Our mission is to undertake and complete projects that will benefit the local community while providing RWU students with experience in real-world projects that deepen their academic experiences.

CPC projects draw upon the skills and experience of students and faculty from RWU programs in areas such as:

- Architecture and Urban Design
- Historic Preservation
- Law
- Justice Studies
- Business
- Education
- Engineering and Construction Management
- Environmental Science and Sustainability
- Community Development
- Visual Arts and Digital Media
- Marketing and Communications
- Graphic Design

Community partnerships broaden and deepen the academic experiences of RWU students by allowing them to work on real-world projects, through curriculum-based and service-learning opportunities collaborating with non-profit and community leaders as they seek to achieve their missions. The services provided by the CPC would normally not be available to these organizations due to their cost and/or diverse needs.

CPC Project Disclaimer: The reader shall understand the following in regards to this project report:

1. The Project is being undertaken in the public interest;
2. The deliverables generated hereunder are intended to provide conceptual information only to assist design and planning and such are not intended, nor should they be used, for construction or other project implementation. Furthermore, professional and/or other services may be needed to ultimately implement the desired goals of the public in ownership of the project served.
3. The parties understand, agree and acknowledge that the deliverables being provided hereunder are

being performed by students who are not licensed and/or otherwise certified as professionals. Neither RWU nor the CPC makes any warranties or guarantees expressed or implied, regarding the deliverables provided pursuant to this Agreement and the quality thereof, and Sponsor should not rely on the assistance as constituting professional advice. RWU, the CPC, the faculty mentor, and the students involved are not covered by professional liability insurance.

4. Neither RWU, the CPC, the faculty mentor, nor the students involved assume responsibility or liability for the deliverables provided hereunder or for any subsequent use by sponsor or other party and Sponsor agrees to indemnify and hold harmless RWU, the Center, the Faculty Mentor, and the Center's student against any and all claims arising out of Sponsor's utilization, sale, or transfer of deliverables provided under this Agreement.



Table of Contents

Introduction - 4

Methodology - 5

Site Investigation - 6

Design Guide Lines - 7

Precedent Analysis - 8

Theater Analysis - 11

Project Results - 15

Conclusion - 19

Sources - 20

Introduction

Executive Summary

Trinity Restoration Inc. (TRI), operating as the Southside Cultural Center (SCC), is a community-based non-profit organization committed to revitalizing and showcasing the cultural capacity of the Greater Providence area through education and the arts. The SCC's goal is to restore the historic theater located in Trinity Square, Southside Providence, RI. The new complex will use renewable energy technologies and 21st century green design to create a world-class, energy-efficient facility. By reinforcing the creative spirit of Providence, the SCC will reach out to people of all different cultures, ages, economic means, and abilities.

The need for an art and educational program, such as the SCC, has been identified strongly within the Rhode Island community and Trinity Square's location within South Providence has been recognized as a prime area of focus. The SCC has developed collaborative partnerships for funding and program development with many regional organizations. The partners include; Community Partnerships Center at Roger Williams University, The Rhode Island Foundation, Social Venture Partnerships-RI, the Carter Family Charitable Trust, Johnson & Wales University, Stop Wasting Abandoned Property (SWAP), RI Council for the Arts, Rebuilding Together Providence, and the Mayor's Office City of Providence.

The Roger Williams University (RWU) Community Partnerships Center (CPC) formed its project partnership with TRI in the spring of 2013. The CPC was asked to explore design ideas and create graphics for the theater space. The CPC assigned two students from RWU's School of Architecture, Art and Historic Preservation to analyze the existing conditions and use their knowledge of architecture and historic preservation to assist with the project development. The project allowed the students to apply their training while receiving hands-on learning and providing project-based assistance.



Methodology

Our Approach

This CPC project was based on a client-architect relationship that followed a project scope agreed upon by both parties. Under the guidance of CPC Director Arnold Robinson and CPC Project Coordinator, Stephany Hessler, CPC Project Managers Vincent Lemma and Jacob Wheeler completed the following tasks:

Site Investigation: The student team visited the site on several occasions to sketch and measure the interior layout of the theater space. The results of the investigation were used to create scaled floor plans in Auto-CAD.

Design Guidelines: With the help of fellow CPC Project Manager Meghan Spratt, the team conducted research on the code requirements that would effect the project. The results of the investigation were used to create project design guidelines.

Precedent Analysis: To help understand the specific needs of theaters, the student team researched other performing spaces. This was broken up into 3 segments; staging, seating, and lighting. A matrix of the results was then compiled.

Theater Analysis: Based on observed conditions, knowledge of architecture, and extensive research,

the student team analyzed methods of improving the theater space. This investigation focused on both the acoustical and site line needs of the theater. A report of the findings with recommendations was created.

Program Analysis: Several meetings between the client, design professionals, and the student team took place to help develop the program. This output was used to inform the design decisions.

Proposed Vision: After reviewing all of the information, the student team created floor plans and perspectives that aimed at capturing the schematic vision of the space. The floor plans were created in Auto-Cad while the renderings were created in Revit. All images were post-processed using Photoshop. Two presentation boards were then created to assist TRI with fundraising.



(A)



(B)

(A) CPC Project Manager, Jake Wheeler investigates the mezzanine site lines.

(B) CPC Project Manager, Vincent Lemma, conducts a field measurement.

(C) CPC Project Manager Jake Wheeler poses with TRI community partners.



(C)

Site Investigation

Existing Floor Plans

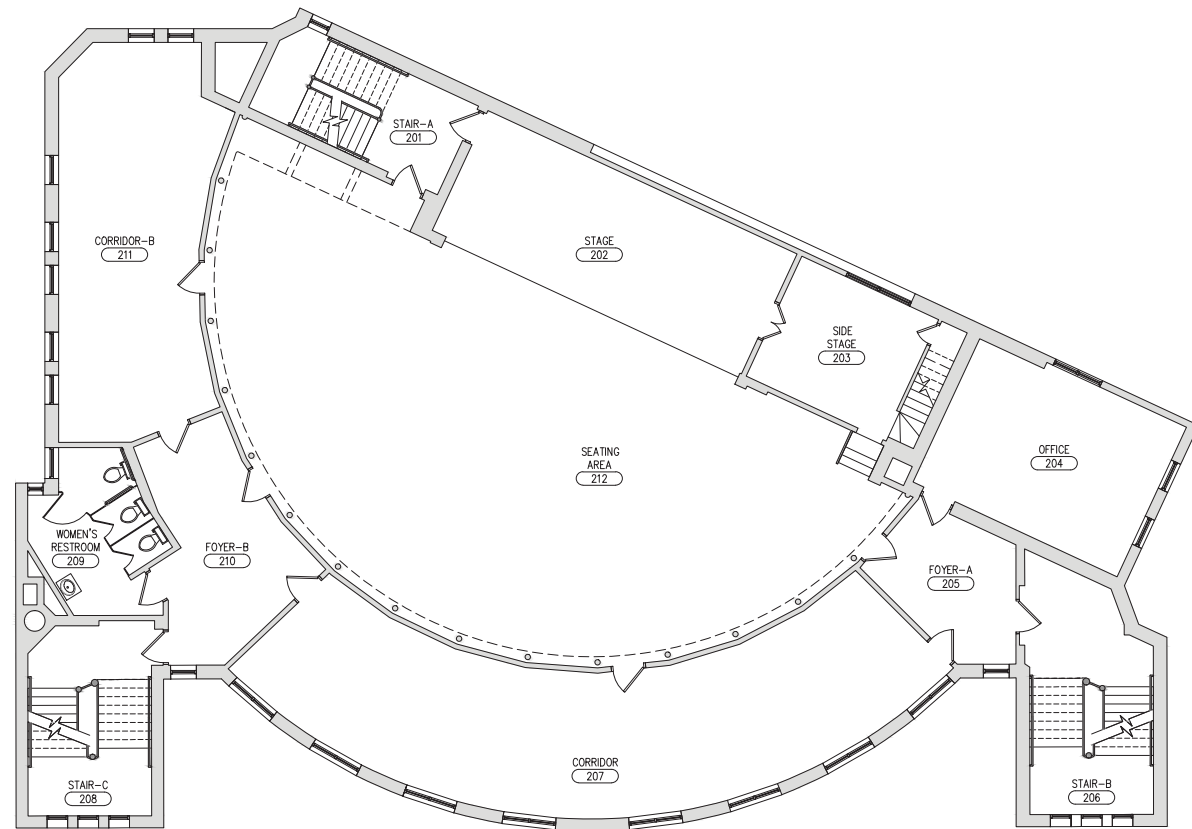

Second Floor

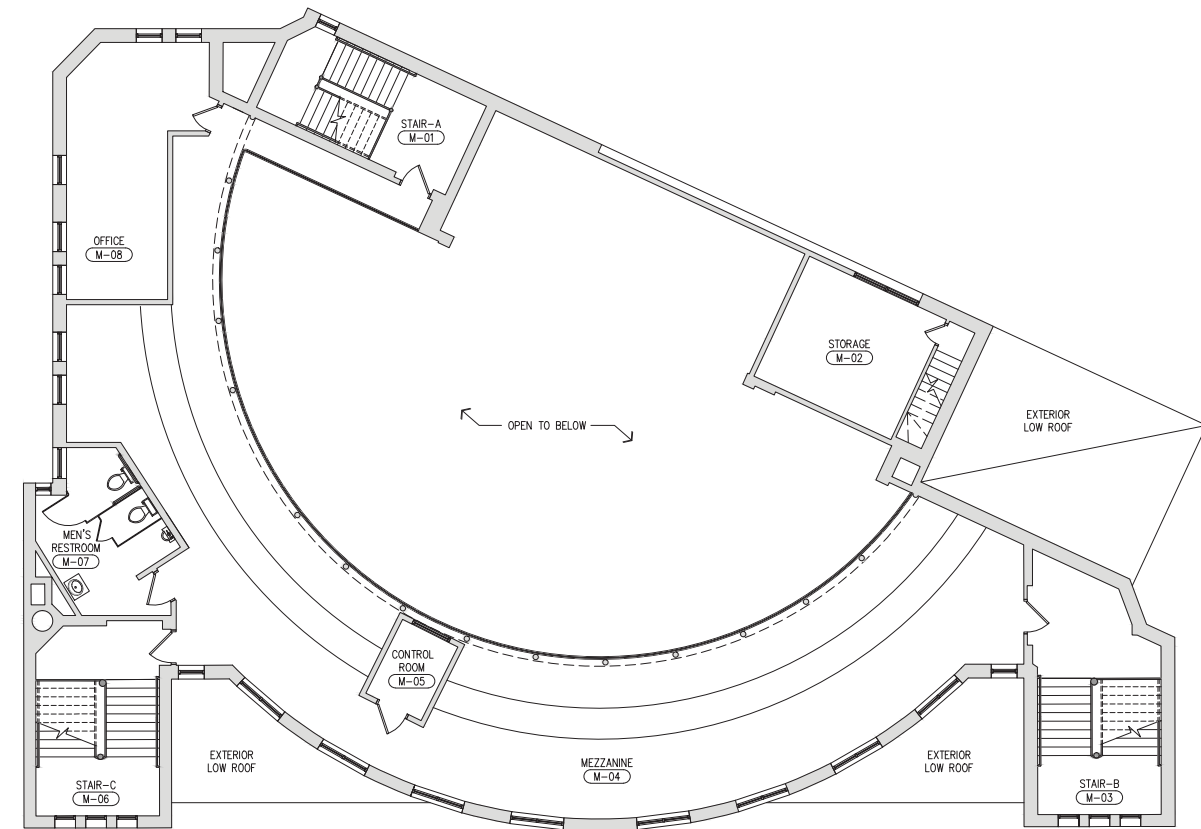

Mezzanine

Design Guide Lines

Code Requirements

International Building Code

Water Closets:

- Male - 1 per every 125 people
- Female - 1 per every 65 people

Lavatories:

- 1 per every 200 people (male & female)

Drinking Fountains:

- 1 per every 500 people

Custodial Needs:

- 1 service sink

Egress:

- 2 means of egress needed
- Path of egress no less than 3' wide
- 2 or more exits from stage needed
- Exit access stairway and ramp from stage are not required to be enclosed
- Length of travel distance not to be greater than 300' for a building without a sprinkler and 400' with a sprinkler

Stairs

- Riser height should not exceed 8-1/4".
- The difference between the greatest riser

height and the smallest should be no more than 3/8"

- Minimum tread should be no less than 9"
- The difference between the greatest and smallest tread width should be no more than 3/8"

Railing Height:

- No less than 36" high (RI-BC)

Handicap Spaces:

- 101 to 300 seating requires 5 handicap spaces with 1 companion seat

Aisles:

- 48" - Aisle stairs having seating on each side
 - Exception - 30" less than 50 seats
- 42" - Seating on each side
 - Exception - 36" is less than 50 seats
- 36" - Aisle stair with seating on one side

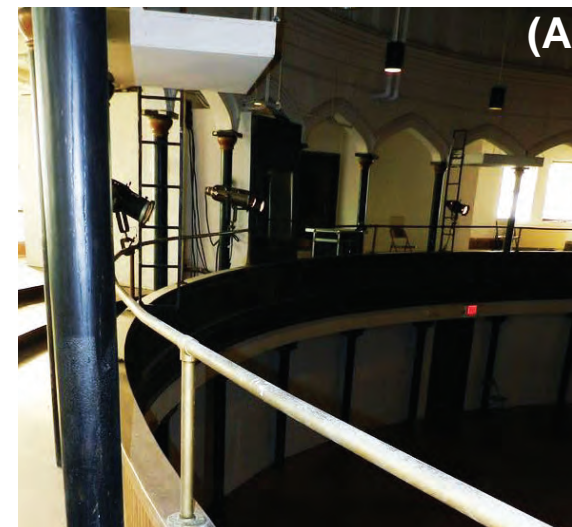

(A)



(B)

(A) Mezzanine hand rail

(B) View from stairwell

(C) View from Mezzanine

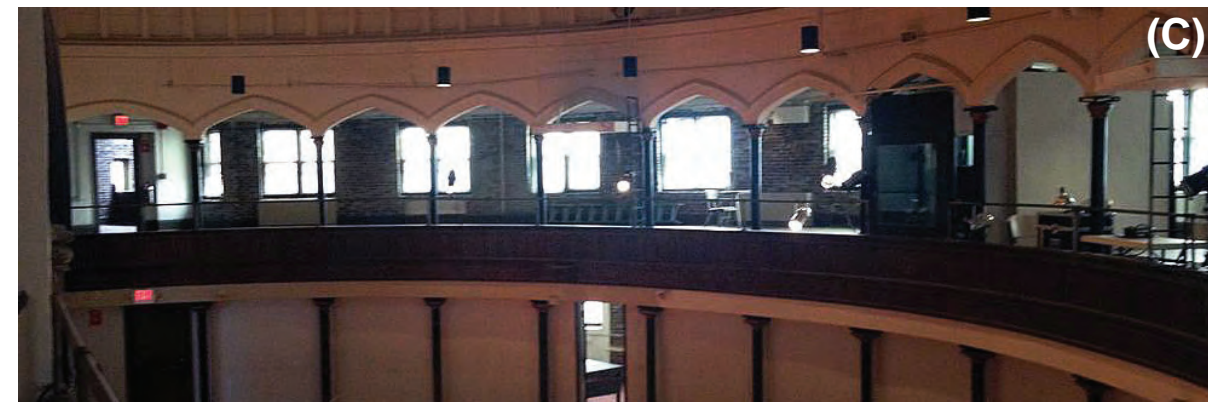

(C)

Precedent Analysis

Staging



The Marilyn and Charles Baillie Theatre

Located at the Young Centre for the Performing Arts in Ontario, Canada, this building holds approximately 315 seats. The theater is a multi-configurable space with orchestra and balcony seating. It is set up with a proscenium configuration but can be rearranged for other functions.



Edmonds C.C. Black Box Theater

Located in Edmonds, Washington, this “Black Box” theater implements a design that accommodates flexibility for seating, stage layout and AV device locations. This approach allows scheduling to become easier since different uses can be set up quickly.



Kogod Theatre

Located at the University of Maryland, this multi-purpose, flexible theater can accommodate various seating configurations for a maximum capacity of 156 people. In addition, a modular stage can be manipulated to suit the needs of individual performances.



Portable and Modular Stages

There are many stages that can be moved into place using mobile techniques such as wheeled systems. These lightweight systems allow for easy storage. The above system is able to be folded up and rolled to the desired destination. Some lower budget theaters use them as permanent stages.

Precedent Analysis

Seating



Old Town School of Folk Music

Located in Chicago, Illinois, this renovated library was turned into a 400-seat concert hall with an upper balcony. There is fixed seating on the balcony as well as fixed “bench” seating on the main level. In addition, moveable table and chair sets are placed along the front of the stage to allow for flexibility from performance to performance. During the day, the theater entry doors are opened which allows the space to be used for café seating.

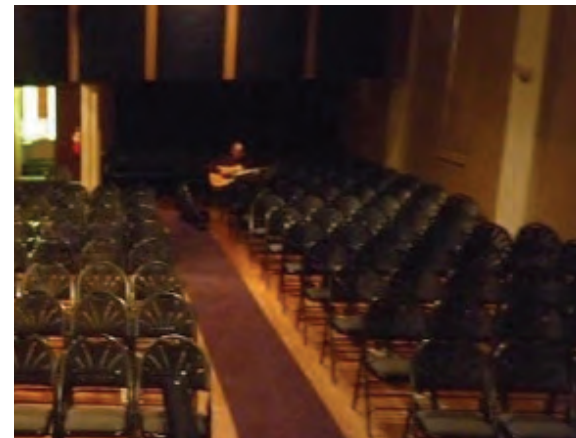

Daniel's Hall, Swallow Hill Music

Located in Denver, Colorado, this folk and acoustic school features a 300-seat performance hall which aims to be as flexible as possible. The fully moveable chair configuration is used to have productions ranging from traditional concerts, dance events, and cabaret.



Trinity Repertory Company

Located in the Providence, Rhode Island this historic building houses two performance spaces. The lower level theater houses 286 seats, while the upper performing space holds over 500 seats. The large performance hall offers an assisted listening system so the hearing impaired are not restricted to up-front seating.



Mayne Stage

Located in Chicago, Illinois, the former Morse Theater, is able to be utilized as two different venue options. The theater can hold a capacity of 220 people when the space is filled with tables. When an event calls for mixed audience seating, 400 people can fit with a mix of standing spaces and additional seating.

Precedent Analysis

Lighting



Lost Nation Theater

Located in, Montpelier, Vermont, this hall is known for its versatility. Theater lighting is often laid out in the form of grids. This theater decided to use catwalks for their grid format. To avoid distraction, the catwalks were painted the same color as the ceiling. This approach makes it easy for lights to be altered for different performance types.



The Renee & Henry Segerstrom Hall

Located in Costa Mesa, California, this building implements a wide variety of LED Lights to achieve dazzling effects. In 2008, this space won an award of excellence for the International Illumination Design Awards. The LED lights wash down the 4' high fronts of the curved balcony. Accent lights, and fiber optics are also used in the lobby before entering the performance space.



Minneapolis Convention Center

Located in Minneapolis, Minnesota, this large venue is often broken down to accommodate smaller events. The xenon fixtures are secured and accessible from catwalks to allow for quick changes. This lighting is supplemented by 400W quartz (incandescent) down lighting. There large bays are indirectly lighted with surface mounted strip-lights that are concealed behind columns.



Queensland Performing Arts Centre

The Queensland Performing Arts Centre in Brisbane, Australia recently completed a major renovation of its 1800-seat concert hall. Since the installation of energy efficient lighting, energy consumption and cost have decreased. The stage lighting, which was once the top energy user, has fallen well behind other common theater units, such as air-conditioning.

Theater Analysis

Methods For Improvement

Acoustics:

After studying the current acoustical condition of the theater the CPC has identified 3 major concerns.

(A) Circular Form

(B) Large Ceiling Height / Volume

(C) Poor Modular / Age

Below is a description of our findings and proposed solutions. All findings should be consulted with a licensed professional to further diagnose and solve existing acoustical problems.

(A) Circular Form: The two walls identified in Diagram (A) and (B) are problem points for the acoustical quality of this theater. The exterior wall on the mezzanine has been built in a circular pattern and the gypsum wall on the second floor is made up of flat sections set up along a circular arc. These concave rear walls create a unique set of problems.

Problems: (1) Sound travels very quick around the curve of the wall creating a disproportional

amount of sound on the opposite ends of the arc. (2) Sounds that start in front of the curve gets reflected back to a focal point. The location of that focal point moves depending on where the sound is located. As a result, loud refocused echoes are created at the focal point. When heard, the sounds seem to come from a mysterious place. The effects of the curved walls are extremely strong and need to be addressed. One common mistake is over applying absorptive material to the walls. This solves the focal point problem but creates a “dead wall” problem.

Solutions: (1) Apply some acoustic absorptive material at the surface of the curved wall. This will pull the sound to the back of the room. (2) Apply reflective material in a scattered pattern where absorptive material is not implemented. The remaining sounds need to be scattered and reflected in directions away from the focal point. The typical sound scattering device implemented is a curved acoustical panel. This panel is essentially a thin flat plane that is bent to have a reversed curvature to the curve of the wall. This panel will scatter mid and high range sounds. In addition, the panel must also be a bass trap so that the reflecting low frequencies do not focus. (3) An alternative would be to increase the angles and depth of the rear walls. By adding irregular forms and voids, sounds can be

scattered and redistributed throughout the space. This will create a more uniformed acoustical quality to the theater. By mixing the absorption and scattering of sound on curved surfaces, the seating areas can achieve a pleasant acoustical quality. These methods are excellent architectural opportunities and should be integrated into the final design to make a unique trademark for the Trinity Theater.

(B) Large Ceiling Height / Volume: The shear volume and tall ceiling heights of this space will be a major factor when developing the acoustical characteristics of this theater. Special consideration to the sound decay and reverberation time must be addressed.

Problems: A larger room will take a disproportional amount of acoustic work to be fixed in comparison to a smaller room. This can be explained because a big space holds more sound and provides proportionally less surface area than a small room. In addition, a big room makes sound travel farther between impacts on the surface. This slows the erosion of the sound even more. Fortunately, there is one major advantage to having a large space; it holds more people!

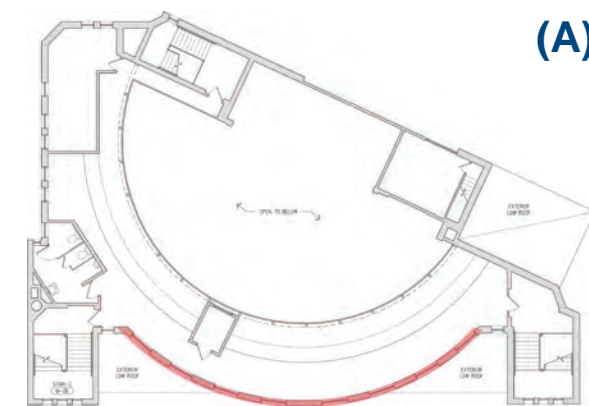

(A) Mezzanine Floor Plan

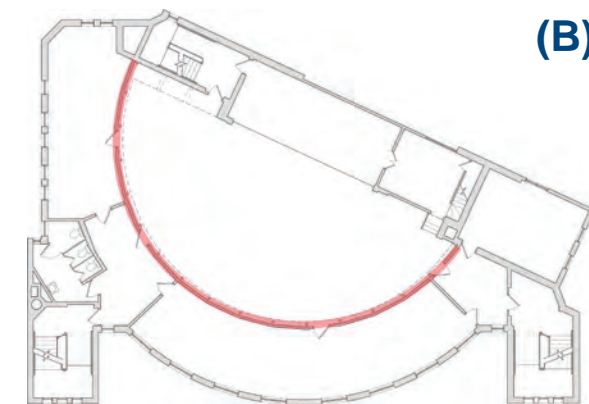

(B) Second Floor Plan

Theater Analysis

Methods For Improvement

Solutions: (1) Create a reflective shell for the interior of the stage to reflect sounds. The proscenium opening can lead to poor acoustic coupling between the stage and seating area. By lowering the ceiling height of the stage and angling the shell towards the audience, sounds will travel outwards instead of above, behind or adjacent to the stage. (2) Construct a platform that can be set up in front of proscenium stage for specific performances. This can greatly minimize the problems associated with the coupling between the stage and auditorium. Unfortunately, the trade-off is in the elimination of seating. (3) Install acoustical panels in front of the stage from the ceiling. The suspended acoustical panels should be adjustable. Different performances call for different panel heights. By making them adjustable the performer can test the heights before the show. (4) Avoid using the foyer space for seating. Overhanging mezzanines are great for creating extra seating but the space below often has poor acoustical qualities. The sound is usually dull and muffled. By following these measures the large size and ceiling heights can become a strength for Trinity Restoration instead of a weakness.

(C) Poor Assembly / Age: The age and current state of disrepair of the space must be fixed to assure quality acoustics.

Problems: To provide effective sound isolation the doors, walls, and roof need to be solidly built with sufficient mass. In addition, any penetrations in these variables or through windows must be sealed to keep the desired sound in and the unwanted noise out.

Solutions: (1) Consult a acoustician about replacing your current windows and doors with sound-rated products. (2) Consult a licensed contractor about repairing the building and sealing all voids that could allow leaks to the exterior of the space. Without eliminating sounds leakage, any efforts to improve the acoustics of this space will be under minded.

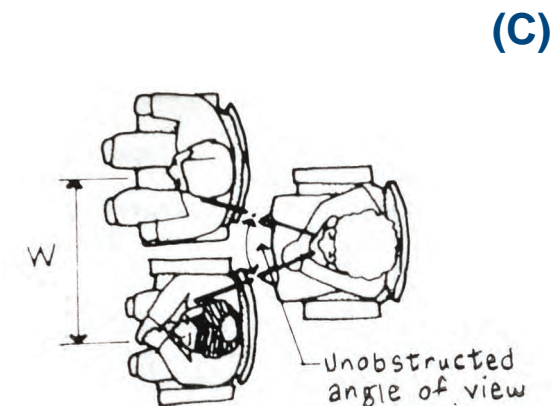
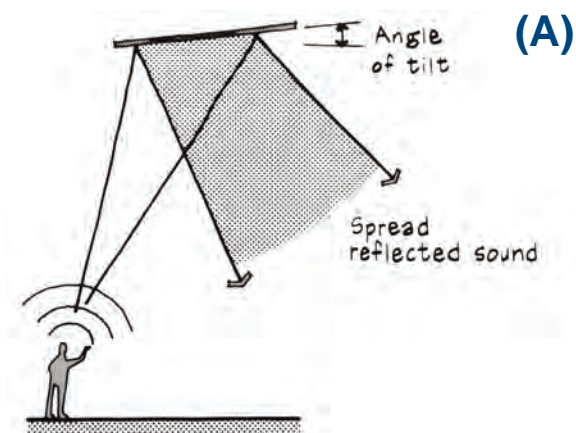

(A) A typical reflector spreads sound. The angle of tilt can be changed depending on the performance or occupancy.

(B) Constructing a platform in front of proscenium stage can minimize the problems associated with the coupling between the stage and auditorium. It puts the performance closer to the audience and allows the desired sound to be spread outward instead of being misguided.

(C) If you can see the source you can hear the source. This is a good rule of thumb for seating layouts.

(D) Sufficient mass is necessary to keep desired sound in and unwanted noise out. All penetrations must be properly repaired.

Theater Analysis

Methods For Improvement

Site Lines:

Mezzanine Investigation: Visual connection is vital for theater design. Site lines are important design factors that must be kept in mind during the design process. The final design must create a built environment and a circulation that does not obstruct any views. The column arrangement and handrail position on the mezzanine will force a rigorous design approach to create seating with desired site lines. The current condition of the mezzanine has two levels but there may be a possibility to increase higher seating capacity by adding another seating section.

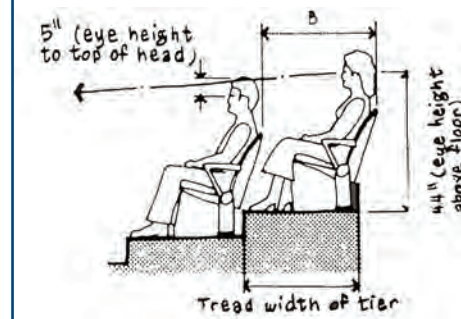
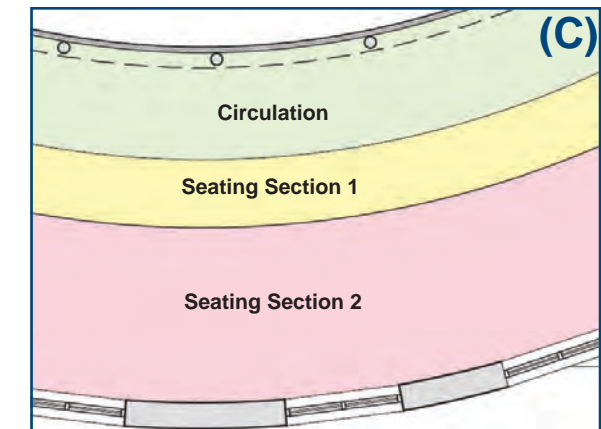
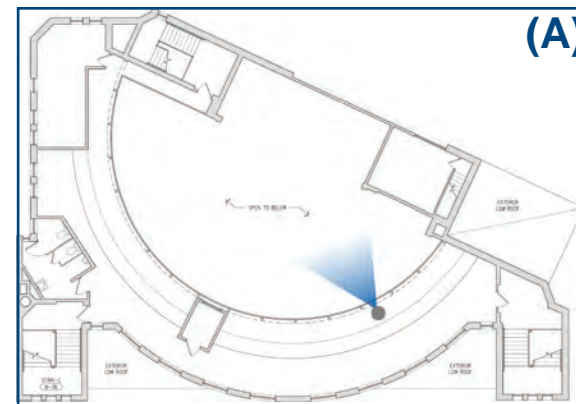

(A) Mezzanine Floor Plan with visual icon indicating view of stage.

(B) Mezzanine Floor Plan with visual icon indicating view of stage.

(C) Diagram showing current seating arrangement and the a typical stadium seating section.

Theater Analysis

Methods For Improvement

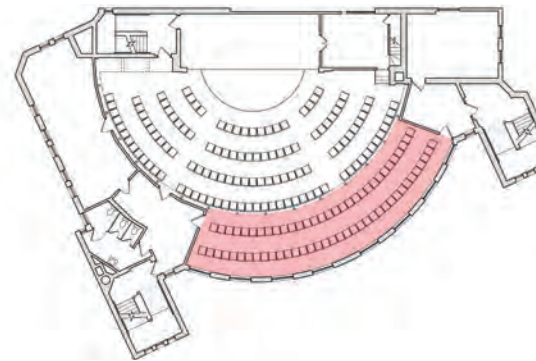

1 - Select space

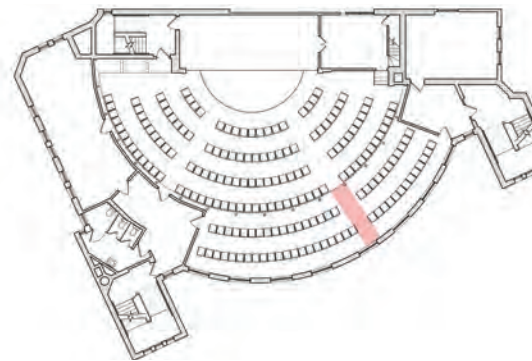

2 - Remove seats for main aisle

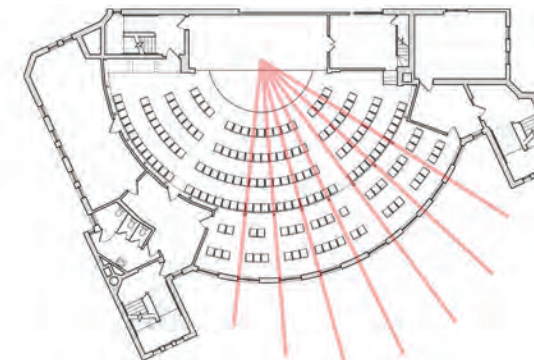

3 - Remove seats due to columns

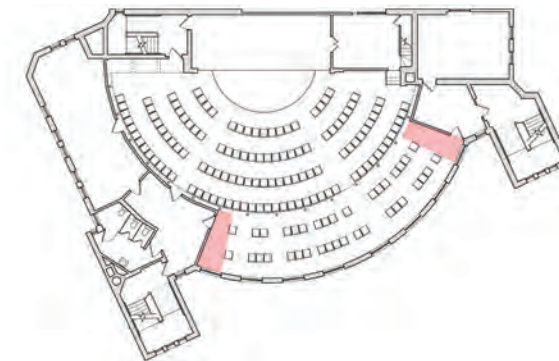

4 - Remove seats for side aisles

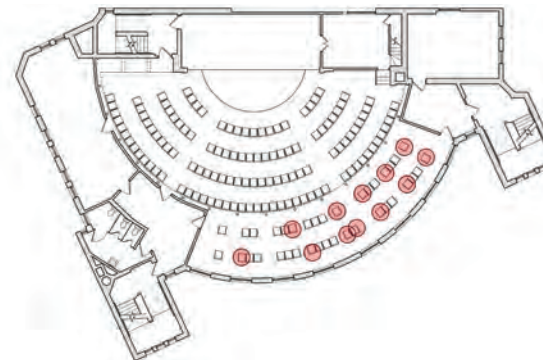

5 - Remove seats due to poor site lines

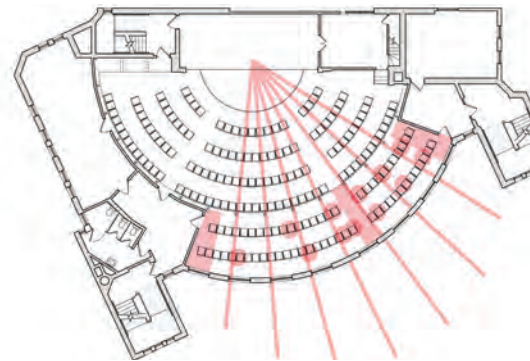

6 - Check results against project objection

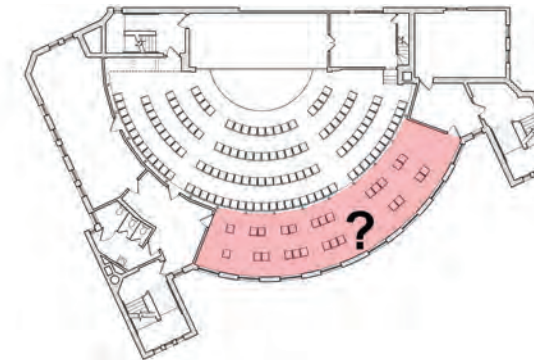

7 - Evaluate situation

Corridor Investigation: The space below the mezzanine has the possibility to hold many programs. One possibility is to open the space up as an extension to the theater seating. The CPC investigated the site lines in the space and concluded that the seating would not be able to hold a large amount of seats with high quality views. If TRI does pursue connecting the two spaces, the CPC recommends utilizing the space for unconcentrated seating. This style would allow for group seating options.

Project Results

Floor Plans

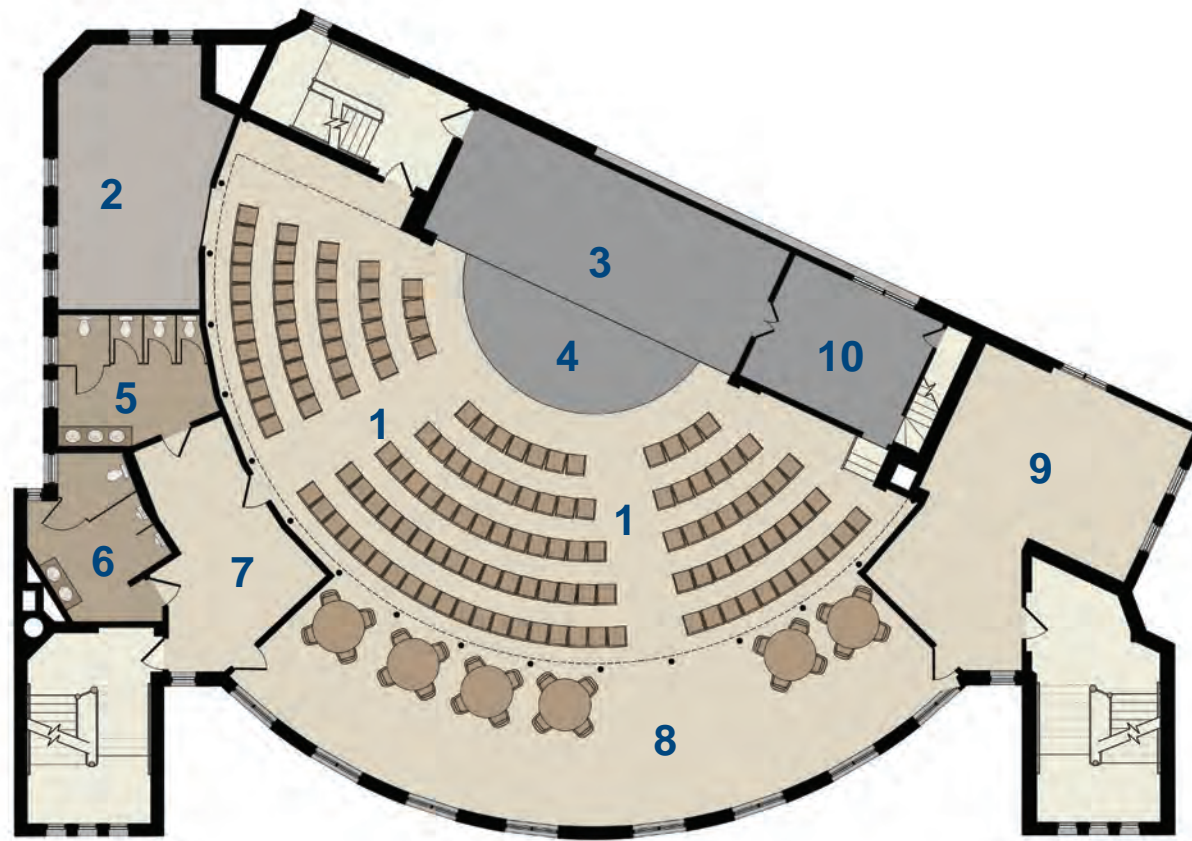

Second Floor

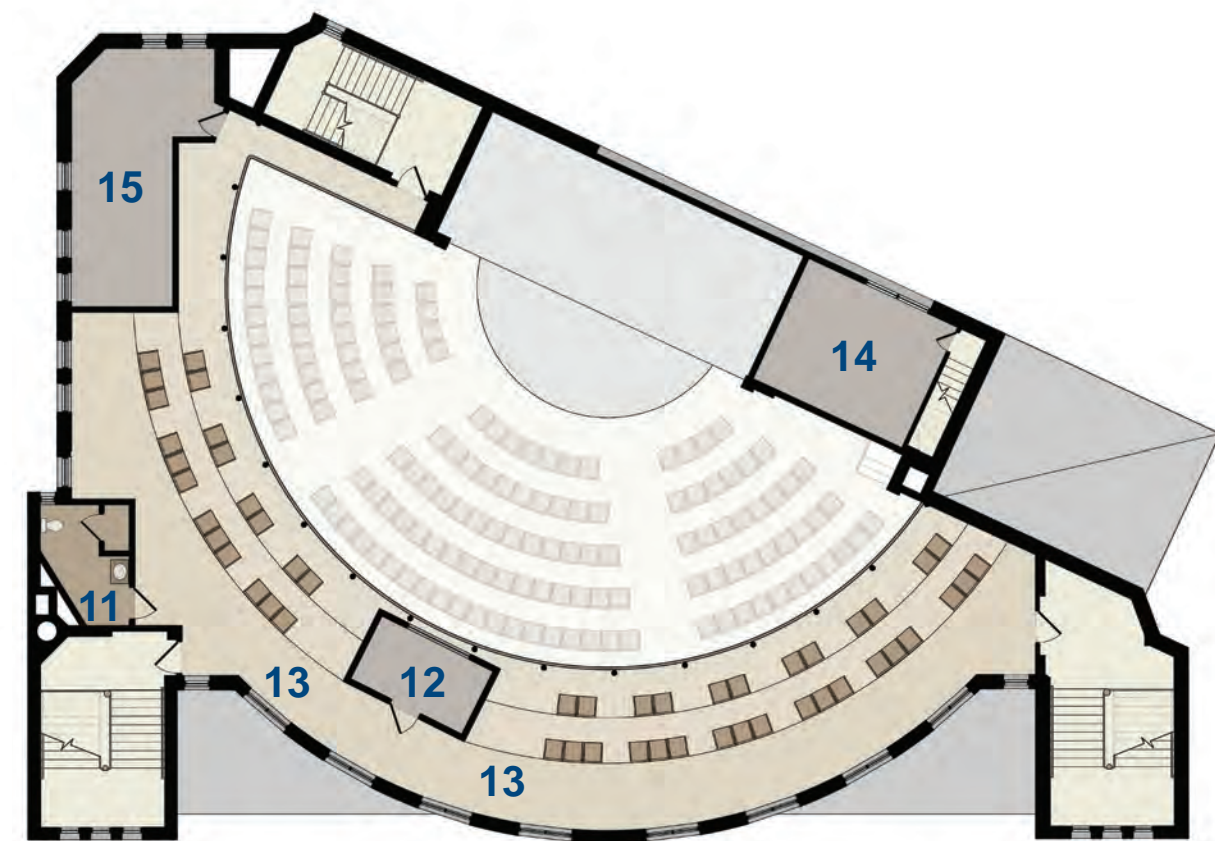

Mezzanine

Program:

- | | | |
|----------------------|--------------------|----------------------|
| 1 - Seating Area | 6 - Men's Bathroom | 11 - Unisex Bathroom |
| 2 - Storage | 7 - Foyer | 12 - Control Room |
| 3 - Stage | 8 - Flexible Space | 13 - Seating Area |
| 4 - Stage Extension | 9 - Sales | 14 - Storage |
| 5 - Women's Bathroom | 10 - Side Stage | 15 - Changing Room |

Project Results

Perspectives



Project Results

Perspectives



Project Results

Perspectives



Conclusions

Final Remarks



This report is the culmination of a semesters worth of work of the students and staff involved in the RWU Community Partnerships Center. The process and work products will hopefully assist Trinity Restoration Inc. as it continues its design process. The project has also provided CPC Project Managers, Vincent Lemma and Jacob Wheeler, with a valuable experience in the design development process, furthering their training as future architects.

THE TRINITY PROJECT
Community Partner: Trinity Restoration, Inc.

cpc
Community Partnerships Center
at Roger Williams University

Roger Williams University:

In the spirit of educational collaboration, the Southside Cultural Center has teamed up with the Community Partnerships Center at Roger Williams University. This opportunity has allowed students first hand experience to work with a site listed on the National Register of Historic Places. Since partnering, the selected RWU Architecture students have been working on programming, schematic design, and renderings.

Curtain Design:

The material, ZEZ® fabric, being proposed for the Trinity Restoration Theater has been developed by Providence based designer Wanda Miglus. ZEZ® fabric is an optically interactive textile whose visual effect functions much like a hologram or lenticular graphic, where images/patterns change depending on the viewer's visual relationship to the fabric. This woven fabric is produced through commercially existing weaving technology and fibers.

Poster -1

THE TRINITY PROJECT
Community Partner: Trinity Restoration, Inc.

cpc
Community Partnerships Center
at Roger Williams University

Mission:

Trinity Restoration Inc. operating as the Southside Cultural Center is a community based non-profit organization committed to revitalizing and showcasing the community's cultural capacity through education and the arts. By supporting our core value, "Energy In, Energy Out" we can become both a catalyst for sustainability and community engagement. The Southside Cultural Center will be a vibrant, fiscally strong organization that combines the warmth and immediacy of shared arts participation with an efficient patron interface at every point of contact. Our goal is to actively engage a large and diverse constituency in superb ecologically sustainable facilities through program options that reflect the diversity of Providence. By reinforcing the creative spirit of our capital, we can reach out to people of all cultures, ages, economic means, and abilities.



Mezzanine

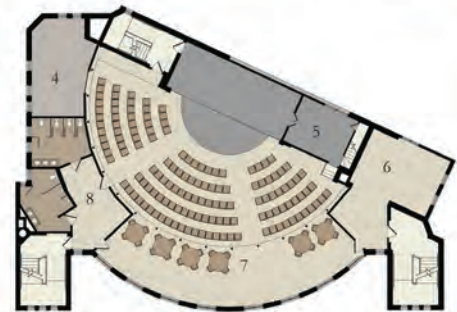

Second Floor:

Program:
1: Changing Room 2: Storage 3: Control Room 4: Storage 5: Side Stage 6: Foyer 7: Flexible Space 8: Foyer

ENERGY IN, ENERGY OUT

Poster -2

Sources

Graphic & Information Resources

- <http://www.claricesmithcenter.umd.edu/venues/kogod-theatre>
- <http://www.flickr.com/photos/minneapolisorg/2496920195/>
- http://www.greenbusch.com/audio_video_design_performance_space.html
- http://www.home.onemain.com/~home_range/perf_ctr/
- <http://www.measurement-testing.com/architectual-acoustics-3-0.html>
- <http://www.oldtownschool.org/>
- http://www.pacificchorale.org/concerts_and_events/segerstrom_concert_hall.php
- <http://www.qpac.com.au/>
- http://www.youngcentre.ca/our_venues/
- <https://www.swallowhillmusic.org/>
- <https://www.trinityrep.com/>
- <https://www.vermontartscouncil.org>
- <https://www.wbez.org>



Roger Williams University
One Old Ferry Road
Bristol, Rhode Island 02809

cpc@rwu.edu
<http://cpc.rwu.edu>