

9-28-2011

An Architecture Of Connection

Jessie Renee Davey-Mallo

Roger Williams University, jrdm87@gmail.com

Follow this and additional works at: <http://docs.rwu.edu/archthese>



Part of the [Architecture Commons](#)

Recommended Citation

Davey-Mallo, Jessie Renee, "An Architecture Of Connection" (2011). *Architecture Theses*. Paper 73.
<http://docs.rwu.edu/archthese/73>

This Thesis is brought to you for free and open access by the School of Architecture, Art, and Historic Preservation Theses at DOCS@RWU. It has been accepted for inclusion in Architecture Theses by an authorized administrator of DOCS@RWU. For more information, please contact mwu@rwu.edu.

AN ARCHITECTURE OF CONNECTION
AN INFRASTRUCTURE PROJECT FOR A MIXED USE REDEVELOPMENT IN
EAU CLAIRE, WI

Independent Project submitted to:

Roger Williams University
School of Architecture, Art and Historic Preservation

In fulfillment of the requirements of the

M.Arch Degree in Architecture

2011

By:

Jessie Renee Davey-Mallo _____

Class of 2011

Stephen White _____

Dean
Distinguished Professor of Architecture & Historic Preservation

Hasan-Uddin Khan _____

Advisor
Distinguished Professor of Architecture & Historic Preservation

AN ARCHITECTURE OF CONNECTION

Jessie Renee Davey-Mallo

Project Proposal Advisor

Dean Stephen White

Primary Advisor

Hasan-Uddin Khan

Secondary Advisors

Alex Anmahian; Derek Bradford; Edgar Adams;
Robert Dermody; Vin Giambertone; Ulker Copur

Review 1 Guest Critics

Robert Dermody; Edgar Adams; David Corbin

Review 2 Guest Critics

Mete Turan; Edgar Adams; Lili Hermann, RISD;
Catherine Truman, AIA, Ann Beha Architects

Review 4 Guest Critics

Edgar Adams, David Corbin, Vincent Giambertone,
Bob Marks, Chris Mulvey, Chip Piati

TABLE OF CONTENTS

01_Introduction

02_Project

03_Site

04_Precedent

01_ BedZed_Zed Factory ltd_Hackbridge, London_2002

02_ Linked Hybrid_Steven Holl_Beijing, China_2003-2009

03_ Genzyme Center_Behnick Architekten_Cambridge, Massachusetts_2003

04_ Ward Residence_ Marmol Radziner and Associates_Pacific Palisades, California_

05_ State Gallery and Chamber Theatre_ James Stirling_Stuttgart, Germany_1977-83

05_Technical Research

01_City of Eau Claire

02_Nature's Cycles

03_Vegetation

04_Green Roofs

05_Vertical Greening

06_Animals

07_IDEX

06_Regulatory

07_Bibliography



layers of use & form & structure
& circulation

“It is evident that ‘life-enhancing’ architecture has to address all the senses simultaneously and fuse our image of self with our experience of the world...The sense of self, strengthened by art and architecture, allows us to engage fully in the mental dimensions of dream, imagination and desire...Significant architecture makes us experience ourselves as complete embodied and spiritual beings.”

-Juhani Pallasmaa

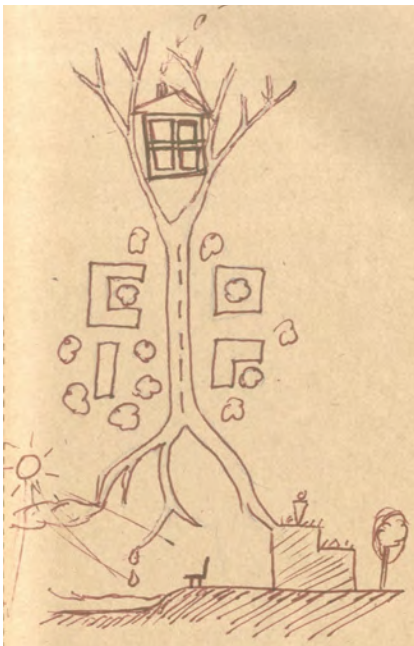

Research indicates that people spend approximately 90 percent of their time indoors.

-EPA

CONNECTION

“Somehow appreciation has to do with a connection with the cosmos, with time, with history & the future with feeling, with caring about the world about the relationship with man and nature.”

-Tangram

This thesis explores the social connections between people and the connections between people and their natural and constructed environment. The conduits through which people perceive their surroundings are the senses, which shape attitudes and activities. Architecture, the design of the physical environment, has a major role in forming these perceptions.

The purpose of architecture is primarily as shelter; however, it is a major influence in the lives of individuals and societies as well as on the environment. As such, it has a responsibility to provide more than the basic function of shelter. Architecture must address social, individual, emotional, mental, physical, and spiritual needs. Among these are contained the need for community and the need for interconnectedness with the natural and built environment. Design considerations in regard to these needs include but are not limited to daylight, views (both interior and exterior), vegetation, water, transportation/circulation, energy, and waste/reuse. These must be taken into consideration at all scales of design and through various means of perception via the engagement of the senses.

Far too often in design, the visual aesthetic is given sole consideration when there are four other senses, each capable of enlivening an environment in different ways. Think of a vivid memory that took place at least ten years ago. With what level of awareness can you recall that memory? With how many senses can you recall it? The point is that perception of environment is fundamental to how people behave and what people remember. People’s subjective and objective perceptions of place are directly dependent upon the senses. This mixed use project (consisting of retail, housing, offices, community gardens and a living machine for waste water treatment) aims to provide a symbiotic relationship between and a heightened awareness of people and the environment.

Architecture should create a link between people and the natural environment, an innate connection that has lost its potency in society. This calls for an integration of nature into architecture through the systems and organization of the built environment. New constructions should minimize their impact on the ecosystem, for example by displacing rather than destroying nature through the use of green roofs and living walls, thus contributing to the environment rather than draining and dominating the environment. These displaced surfaces should act as a dy-

namic habitat rather than a thin layer of vegetation. In addition, an environment should be as self sustaining as possible from a single detail to an entire city.

SENSORY CONNECTIONS

Sight

Having natural light is a foundation from which to build, not a goal to be reached. Views must be provided to connect people with other people and with nature.

(The definition of nature does not merely encompass vegetation, it includes the sky, water, sun, wind, animals—including people—and plants).

Views may also include skylights with views to the sky. Nighttime views to a starlit sky are desirable; however, this requires that the surrounding area does not produce an excess of light pollution. The lack of a site without such conditions is not, however, an excuse to commit the same crime. Light pollution must be reduced.

Being able to observe birds at a feeder does not have to occur solely in rural locations. Colorful plantings may also be provided.

Instead of a rainy day making gloomy conditions, watching the rain strike a water sculpture may provide interest, even gleeful anticipation of rain.

Visual texture is also a design concern, particularly when choosing materials and rhythms.

Touch

Being able to see nature is pleasant, but not as pleasant as being in nature. For that, touch is required. Bringing plantings into a building or extending the space to include the exterior environment can aid in this.

Choice of materials may provide different tactile environments, thus relieving or enlivening an otherwise monotonous surface or space.

Further, it should be taken into consideration that sitting in the sun is a pleasant experience; however, this should be capable of alteration by individuals due to the potential of glare and overheating.



Scent



Environments should not smell like outgassing materials, dust, or stale air. Sustainable building urges natural ventilation, even material choice to eliminate these harmful fumes, but further than this, an environment can be made more pleasant by actively designing scent.

Planting scented flowers, trees, shrubs, and vines indoors, at entranceways, along circulation, around apertures, on terraces, roof gardens, and living walls, etc. invite pleasing aromas into a space. Food scents entice people to an area, this being ideal for nodal points.

Taste

Fresh fruit and vegetables are far more delicious than that which has been picked before it is ripe, sprayed with chemicals and preservatives, and shipped half way across the world. Locally grown food is also healthier for the environment.

It could even be useful for restaurants to grow their own food on their roof, or to have a community farmers market from vegetables grown by the residents, perhaps as funding for shared spaces and equipment.

Gardening is a wonderful social activity. Further, it is nice to be able to pick an herb and simply know that you can eat it. These things should not be restricted to rural dwellers; they should be available to everyone.¹

Sound

The sound of cars passing in the street or a noisy hvac system is not pleasant. Vegetation can act as a buffer to these sounds. Beyond this, the sound of wind in leaves or ripples on a pond or rain on a surface are far more soothing and pleasant to listen to. Wind chimes or wind harmonics may also add to the effect. By creating a supportive habitat on a roof or living wall, perhaps birdsong can become a part of urban life as well.



¹ The benefits of urban agriculture are discussed in Staples, Sarah. "Edible Landscape Project turns Slums into Gardens." Urban Agriculture Notes. Can West News Service, October 25, 2004. Date accessed: 7/8/2009. <http://www.cityfarmer.org/edible.html>. The article provides some interesting points, such as the fact that agriculture has been linked to cities far back in history, as well as the belief that it may reduce crime. At the very least, allowing people of low income to grow their own food can be beneficial.

SOCIAL CONNECTIONS

Any environment must facilitate life. This is achieved through meeting the needs of people, among which is social interaction. These goals must be achieved through consideration of design at all scales, from a single detail to a city, for example the design should provide social opportunities through the integration of program, circulation space, and interior and exterior common areas.¹

The key to interconnection is that people are provided the opportunity to interact. Ample community space should be provided such that community events can be held. A daycare provides an excellent opportunity not only for work, but for parents to feel secure in their child's whereabouts and safety while at work, as well as being conveniently located.

There are certain functions which housing must perform. In seeking to create healthy housing that facilitates contemporary styles of living, the question becomes, how does one integrate diversity into a cohesive society.

Not everyone is as physically or mentally capable as other individuals. This should not exclude them from a community such as this building would provide. Units should be provided to facilitate the care of these individuals by allowing space for a caretaker to live adjacent to the unit yet also have direct access when necessary. Similar conditions should be provided for extended family, such as an elderly family member who requires care, a recent graduate who is job hunting, or a laid off family member.

Interconnections between the community created by the building and landscape are of vital importance; however, connections to the community beyond the building are also important. A design should present options and choices rather than restricting the possible, thus creating flexibility. If a building allows for various uses, it can be adapted to future uses, thus being sustainable by lasting and generating less waste from demolition and new construction.

Occupants should have the ability to personalize their space. This will facilitate a stronger connection to the environment and thus encourage maintenance of the environment. It will also make the environment more comfortable for the people within it.

¹ This relates to concepts found in Yeang, Ken. *Designing With Nature: The Ecological Basis for Architectural Design*. New York: McGraw-Hill, Inc, 1995. in which people and the built environment are considered as part of an ecosystem, one that is fully integrated into the surrounding fabric and interdependent upon the systems around it as well as to concepts found in White, Stephen. *Building in the Garden: the Architecture of Joseph Allen Stein in India and California*. Oxford & New York: Oxford University Press, 1993. which also stresses the importance of meeting various human needs. Further, Stein not only wishes to create architecture that does not damage the environment, but which is in touch with the environment, thus stressing the importance of connection to the natural.

Opportunities to share artistic ability can further bond a community. Display of work can provide conversation as well as opportunity for encounters between people. Children's work can be displayed near the residences, while adult work can be displayed further into the building. If an artist is in residence, they could display their work for sale in the public portions of the building. This would be beneficial not only to the residents, but by providing a social function, it can be beneficial to visitors to the building as well. It would also strengthen ties between residents and the community.

NATURE CONNECTIONS

The boundaries of Nature extend beyond individual species to the cycles that keep them alive and to the laws that govern our reality, physics.

Nature works in cycles supporting a vast network of life without producing waste. It demonstrates the truest form of sustainability. People, rather than viewing their actions as part of the cyclical processes of production, distribution, and consumption, behave in a linear fashion that dead-ends at needless and harmful waste. Nothing is truly linear despite popular, surface-glance perception; even time is measured in renewing cycles.

To think that people are separate from or better than nature is ludicrous. We are certainly not the only species to think, learn, use tools, communicate, make dwellings, fight for territory, decorate, and clean.

The global environmental crisis is the result of human kind segregating itself from nature, resulting in people removing themselves from the network of cycles that sustain ALL life. It is not the planet that is in trouble, it is the human race as it exists today that is in jeopardy, along with the countless plant and animal species that are harmed alongside ourselves. Nature abhors a vacuum. Without people, the cycles will continue and eventually a balance will be restored; however, if we as a *species* act NOW, we can find a way to balance the system once more. This can only be achieved by placing ourselves once more *within the network of cycles*.

In order to achieve this re-synthesis, people must be made aware of the existence of these cycles, the impact of them upon people, and not only a community's but especially the individual person's impact upon it. This must be a part of daily life as surely as eating, talking, playing, etc. It is vital that we act now to view the human environment as part of an ecosystem that encompasses not only this entire planet from core to ozone, but the universe beyond our planet, from the microscopic environment around and within ourselves to the systems of planets

and galaxies beyond the Earth's threshold, an environment we have only begun to venture into.

Ecology teaches people to view themselves as part of nature, specifically in the cycles in which we interact, such as the hydrological cycle and the food chain. Each component of the system that is planet Earth is important and has its place as both consumer and producer. This means that a balanced planet requires that we as people share our environment with not only all nations and races, but all species. In embracing this concept, it is the duty of architecture to provide a healthy environment for not only people, but the many plants and animals who reside here.

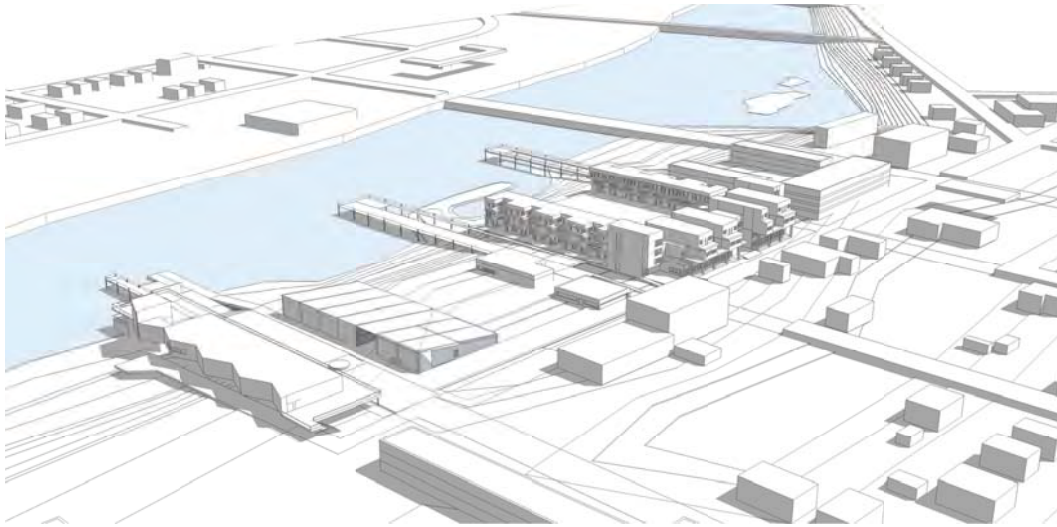

AN INFRASTRUCTURE PROJECT
FOR
MIXED USE REDEVELOPMENT
IN
EAU CLAIRE, WI

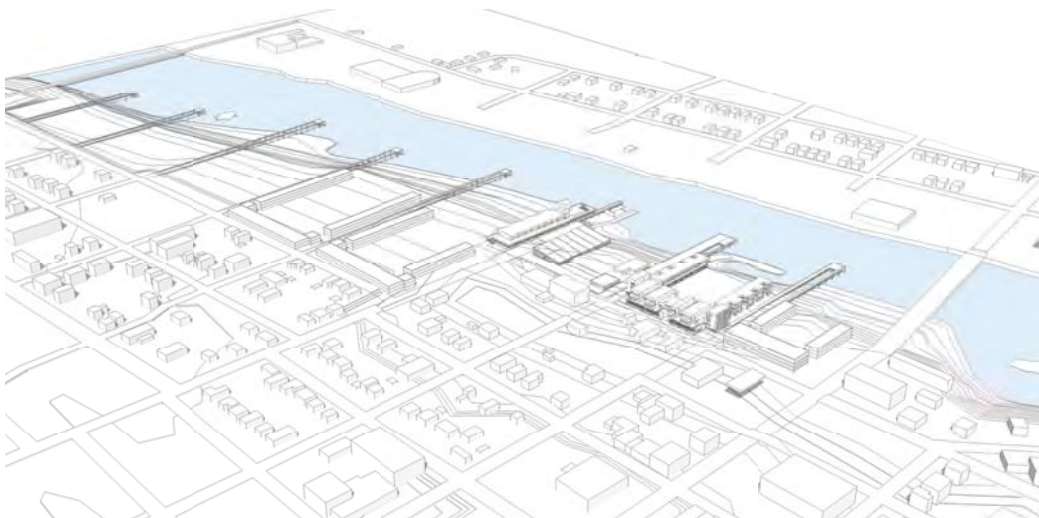

THESIS INTRODUCTION

This thesis explores an architecture of connection between people and their habitat in an infrastructure project in Eau Claire, Wisconsin. The focus is upon the senses because they are the means through which we perceive our environment. In the words of Juhani Pallasmaa:

“It is evident that ‘life-enhancing’ architecture has to address all the senses simultaneously and fuse our image of self with our experience of the world...The sense of self, strengthened by art and architecture, allows us to engage fully in the mental dimensions of dream, imagination and desire.”

The senses also provide a foundation to a sense of place and belonging.

This mixed use project explores the senses in order to make nature connections and social connections to truly link people to habitat and place. This is achieved by responding to the contextual input as well as creating new places with considerations to intensity, direction, enhancement, blocking, and more.

The senses are designed in this project to emphasize social connections at key arteries and nodes at the urban scale.

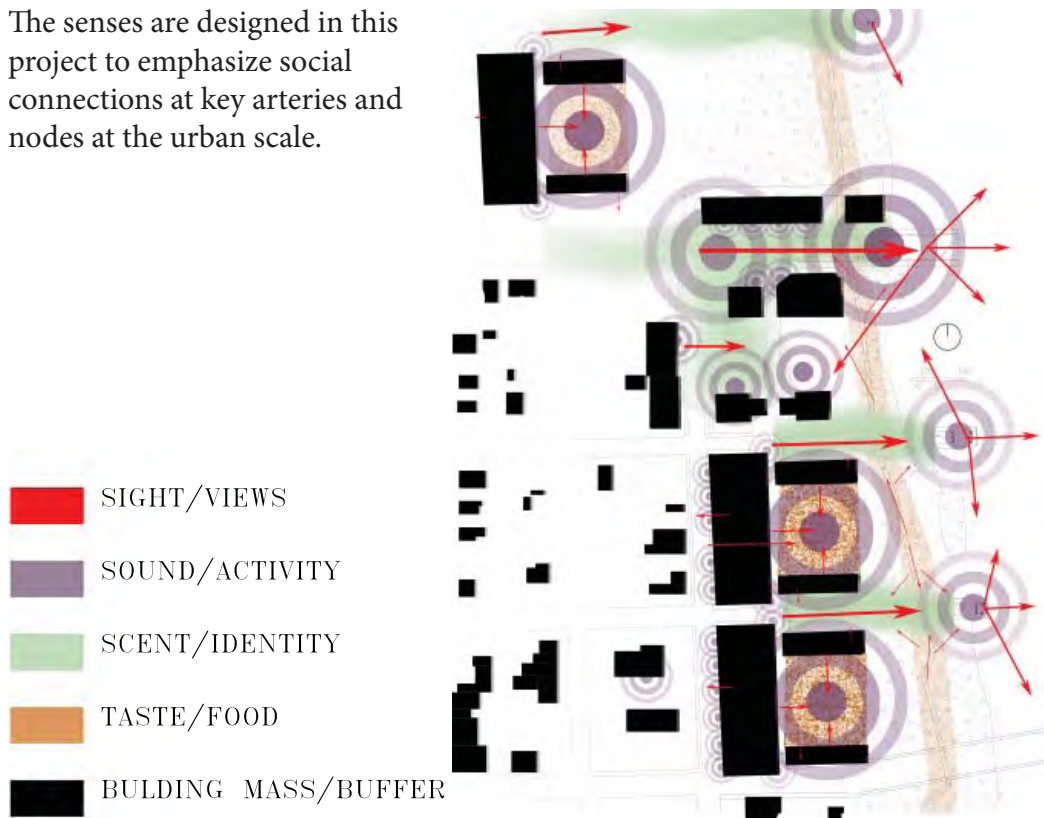



SIGHT

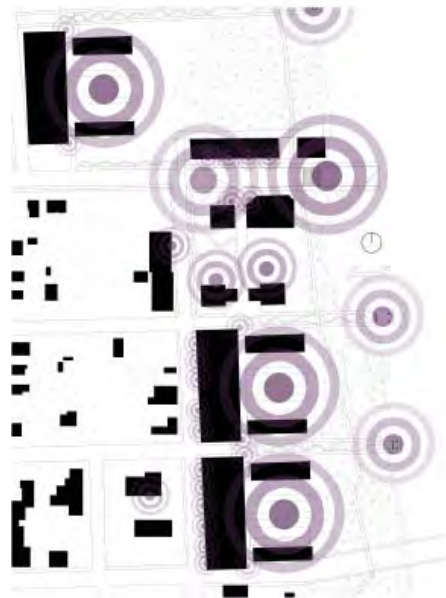

SOUND

-  SIGHT/VIEWS
-  SOUND/ACTIVITY
-  SCENT/IDENTITY
-  TASTE/FOOD
-  BUILDING MASS/BUFFER

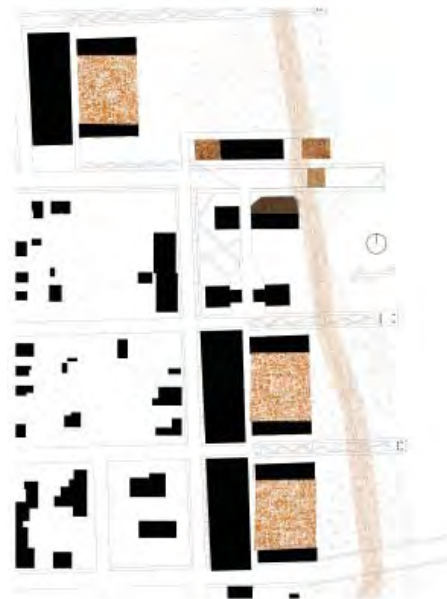

TASTE



SCENT

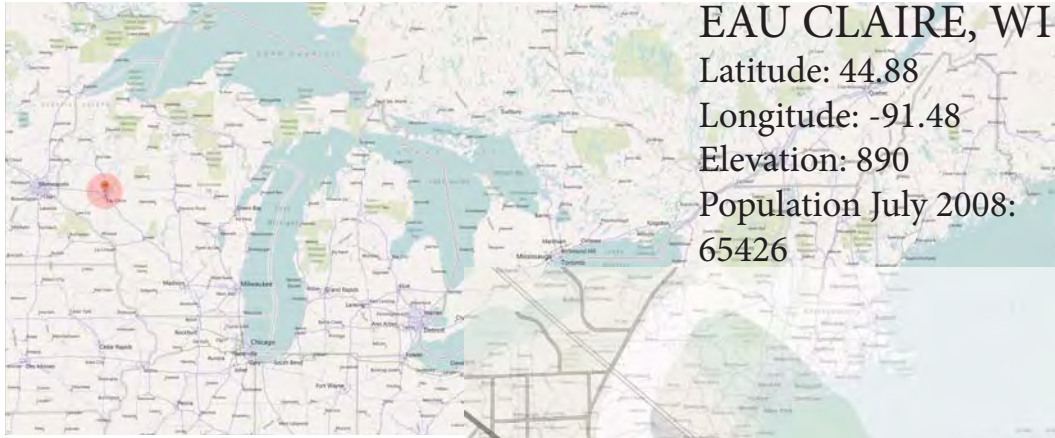

EAU CLAIRE, WI

Latitude: 44.88

Longitude: -91.48

Elevation: 890

Population July 2008:
65426

-  MAJOR CIRCULATION
-  CHIPPEWA RIVER
-  GREEN BELT
-  SITE
-  UW-EAU CLAIRE
-  NORTH BARSTOW
-  HISTORIC DISTRICT
-  COURTHOUSE DISTRICT
-  HOSPITAL DISTRICT

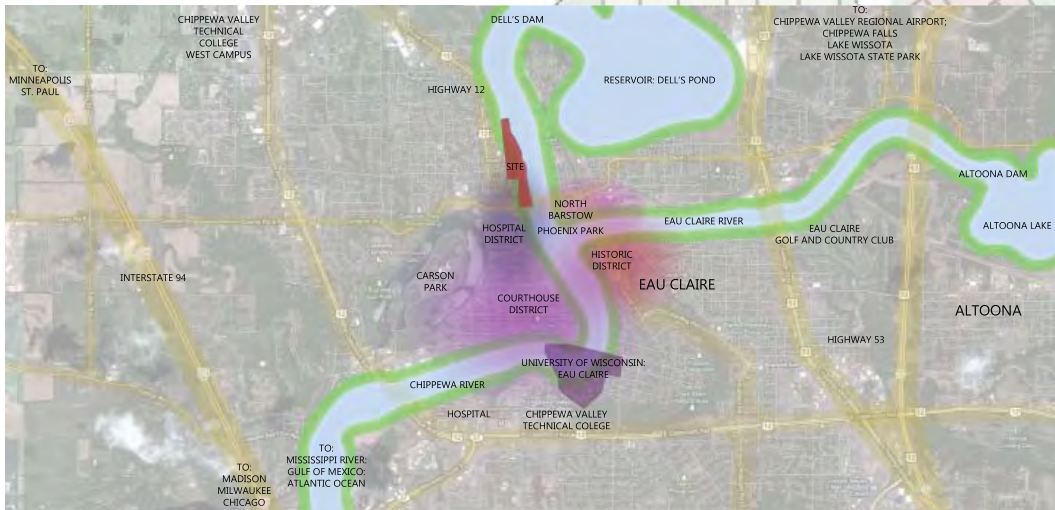

SITE INTRODUCTION

Eau Claire, Wisconsin has a crucial interaction point between the natural and constructed environment where the Chippewa River, a tributary to the Mississippi River, divides the four districts of downtown in half. Dell's Dam provides a reservoir in Dell's Pond to the north. The river is bordered by a thin green belt where the bank slopes from an elevation of roughly 13 feet above the water, these two levels becoming a nature experience below and a gridded urban infrastructure above.



BRIDGE OVER THE CHIPPEWA
RIVER EAU CLAIRE WI
BY: WEOSRA
GOOGLE MAPS



EAU CLAIRE
BY: NKOVA1
GOOGLE MAPS



INFRASTRUCTURE



EAU CLAIRE
BY: NKOVA1
GOOGLE MAPS



EAU CLAIRE DOWNTOWN
BY: J_WEST4
GOOGLE MAPS

EAST BANK

Downtown consists of the Historic District to the south on the east bank and is dominated by brick shops. The Eau Claire River--a tributary to the Chippewa River linking nearby Altoona Lake--is the north-south border between the Historic District and the North Barstow District.

The North Barstow District is currently in the final stages of redevelopment. The early stages saw the creation of Phoenix Park, now the location of a farmer's market as well as a popular place from which to float down the river in the summer. North of the North Barstow District are housing—mostly single-family—a school, industrial buildings, and an expanded patch of green belt.



LUTHER MIDELFORT
BY: NICAMLOPEZ
GOOGLE MAPS



BIKE TRAIL OVER THE CHIPPEWA
RIVER BETWEEN PHOENIX PARK
AND FIRST AVENUE
BY: PRESBADARIOUS
GOOGLE MAPS

WEST BANK

The west bank blurs the courthouse district to the south and the hospital district to the north. Above Madison St, a primary traffic route through downtown bridging the two banks and linking Interstate 94 to the west and Highway 53 to the east, are a few public buildings such as small retail, a gas station, and the Eau Claire Children's Theater, these dissolving quickly into single and multi-family housing.

Traffic branches at Oxford Ave to turn at Platt St in a route to highway 12 to the north. An unused railroad bridge just over ½ mile north of Madison St spans the Chippewa River linking industrial areas on either bank. The Children's Theater is located roughly 1000 feet north of Madison St at the pivotal corner of Oxford Ave & Platt St.



15 of 15 Added De



I chose a 40 acre site on the West Bank that the city of Eau Claire is in the early stages of redeveloping and is currently in the process of removing undesirable buildings. The site extends north from Madison St. to the rail road bridge and is bordered by Oxford Ave, Platt St, and 1st St. The buildings that are being demolished are small retail and industrial buildings.

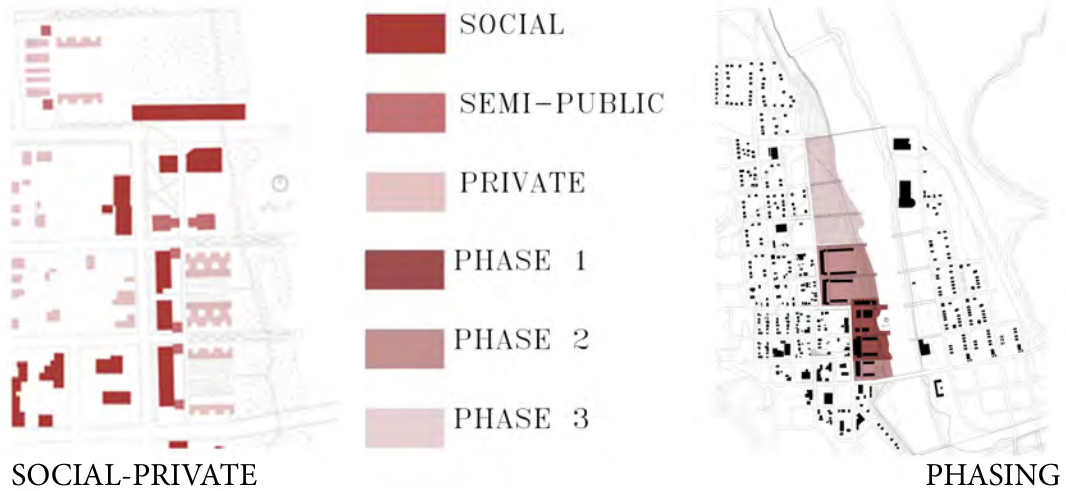

SITE PHOTOS



The site will be developed in 3 phases, the first of which I am focusing on in this project. Program consists of housing, community buildings and spaces, retail, café, restaurant, offices, a living machine for waste water treatment, an outdoor performance space with amphitheater seating, and a dock.

SITE: 40 acres

HOUSING (4 clusters): 259,600 SF

TOTAL EXTENDED: 129,000 SF

TOTAL 3 BEDROOM: 130,600 SF

RETAIL: 40,000 SF

CORNER CAFE: 2,750 SF

RESTAURANT: 5,500 SF

EXPANDABLE SHOPS AND GALLERIES: 8,250 SF

OXFORD AVE: 16,800 SF

OFFICES: 13,500 SF

COMMUNITY: 45,500 SF

LIVING MACHINE: 22,000 SF

DAY CARE: 11,500 SF

COMMUNITY BUILDING: 7,500 SF

PUBLIC BATHROOMS (6): 4,500 SF

SERVICES: 500,000 SF

TOTAL PROGRAM: 858,600 SF; 19.71 acres

TOTAL FOOTPRINT: 181,815 SF; 4.17 acres

GREEN BELT: 1,020,700 SF; 23.43 acres * greater than 50% of the site

CONSTRUCTED WETLANDS: 18,600 SF; 0.43 acres

GREEN ROOFS: 330,000 SF; 7.57 acres

COMMUNITY GARDENS: 246,000 SF; 5.65 acres

TOTAL VEGETATED AREA: 1,615,300 SF; 37.08 acres

SITE STRATEGIES

Responding to the pivotal corner at which the Children's Theater is located, I chose to create a nodal point here to engage the public and to provide a social connection to the river. It is the node that this project focuses upon as well as the first of two clusters of housing to the south of community buildings linking into the node.

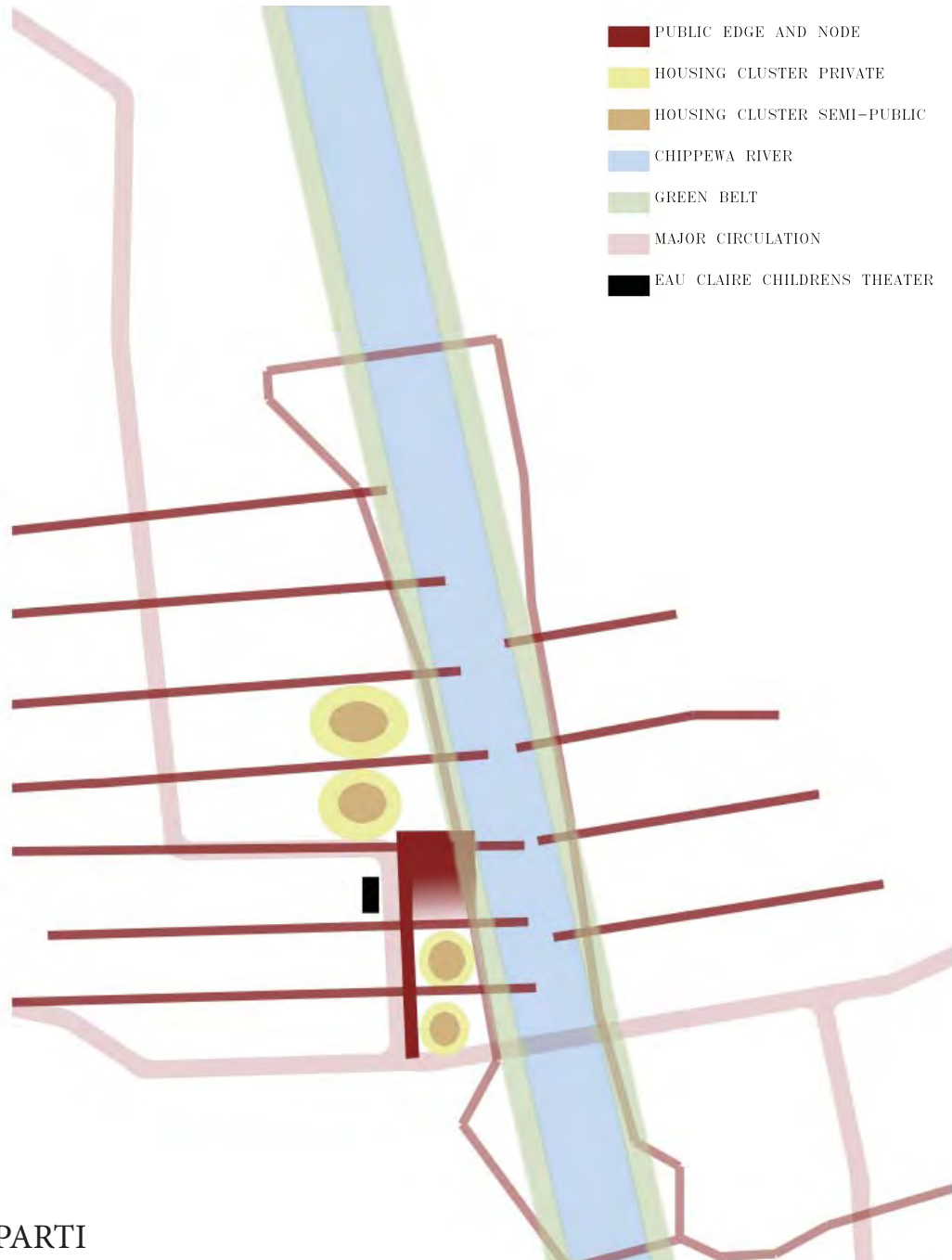

NODE AND LINKS

The existing infrastructure of the street grid allowed me to extend pedestrian linkages to the river which I maintain at an elevation of +13 above the water—the level of the urban grid—this allowing a bicycle path to wind along the river’s edge in a more intimate experience with the surrounding landscape. The links follow swales with scented plantings for runoff water and terminate in piers at which leisure activities can take place at the river’s edge. The link at the node is a special moment where the path is brought into contact with the river at the performance space and dock.



BICYCLE PATH APPROACHING PEDESTRIAN LINK TO RIVER





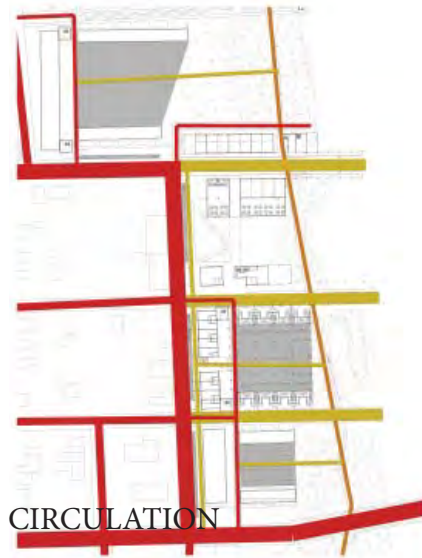







LINK DETAIL
SCALE: 1/8"=1'



-  VEHICULAR STREET
-  BIKE PATH
-  PEDESTRIAN STREET
-  PARKING

LEVEL 2

-  PRIVATE GREEN ROOF
-  COMMUNITY GREEN ROOF
-  VEGETATED PUBLIC NODES
-  LIVING MACHINE
-  PUBLIC BATHROOM
-  RETAIL
-  COMMUNITY
-  RESIDENCE
-  PARKING
-  DELIVERY
-  MECHANICAL

LEVEL 0

LEVEL 3

LEVEL 1

LEVEL 4

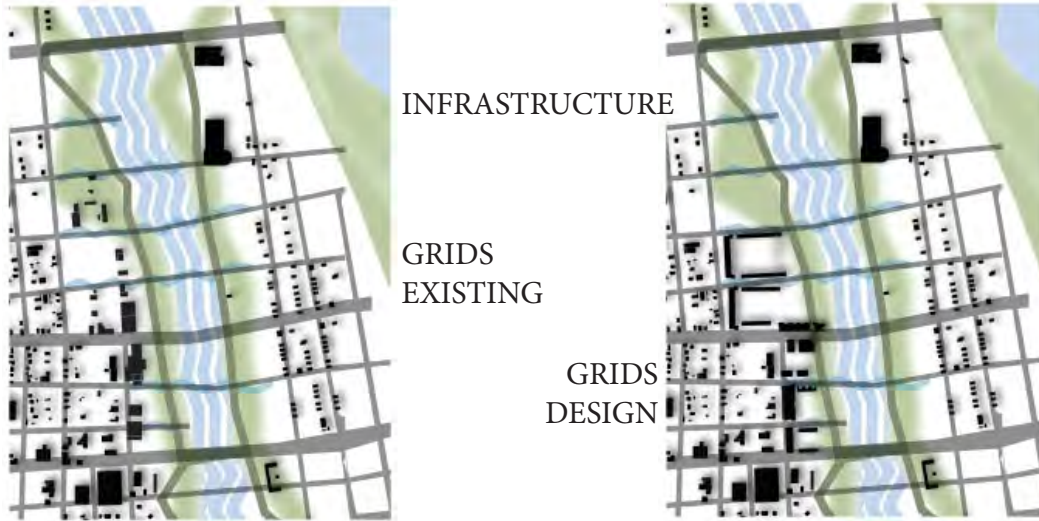

- CHIPPEWA RIVER
- SWALE/OPEN CHANNEL DRAINAGE
- CONSTRUCTED WETLANDS
- LIVING MACHINE TREATMENT CENTER
- PRIMARY CHASE
- SECONDARY CHASE
- GREEN BELT EROSION CONTROL



WATER STRATEGIES

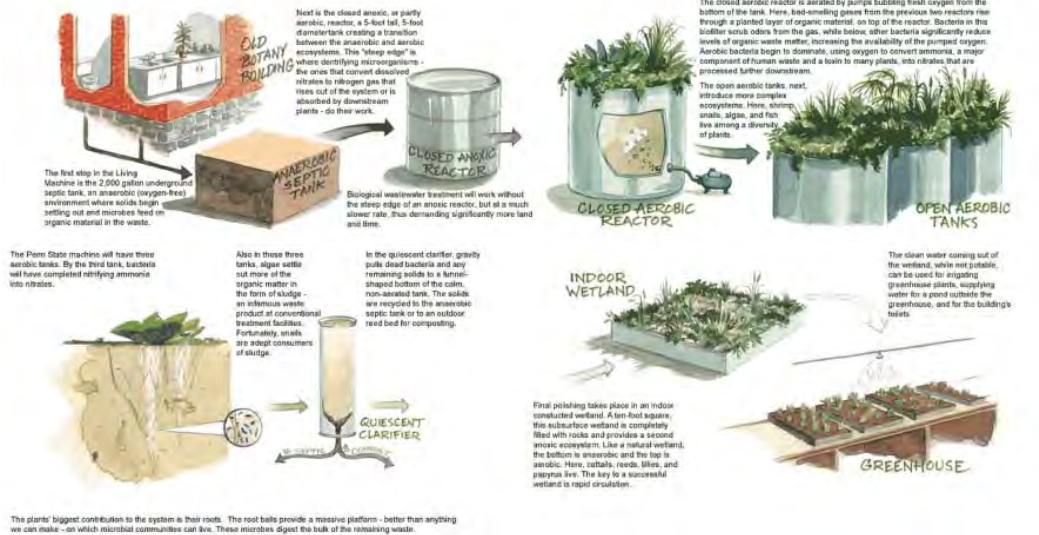

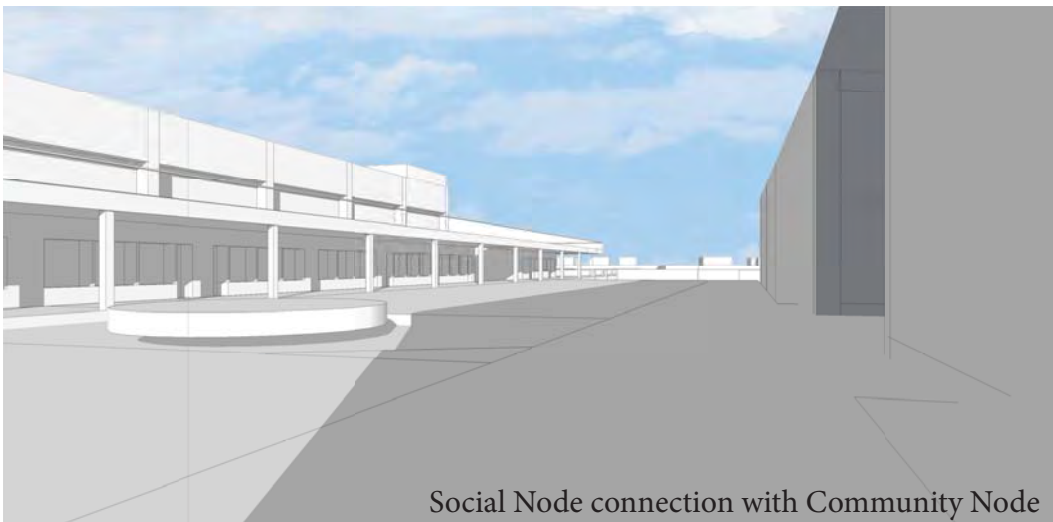

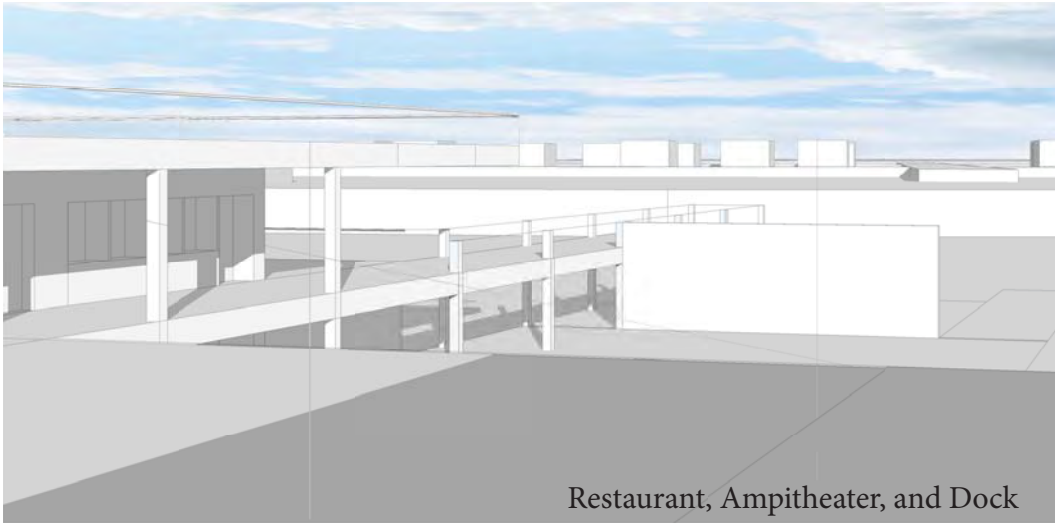

Restaurant, Ampitheater, and Dock



Restaurant, Ampitheater, and Dock

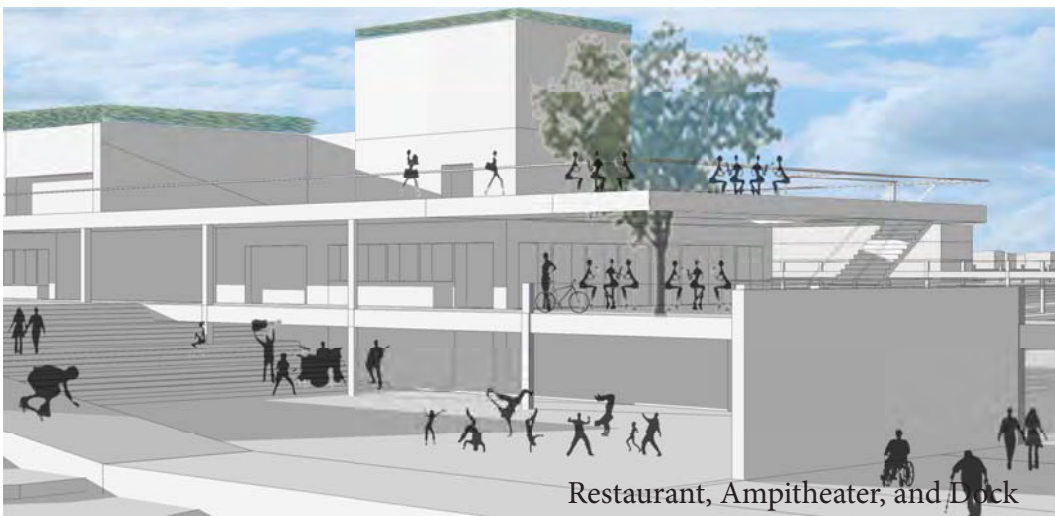

Restaurant, Ampitheater, and Dock

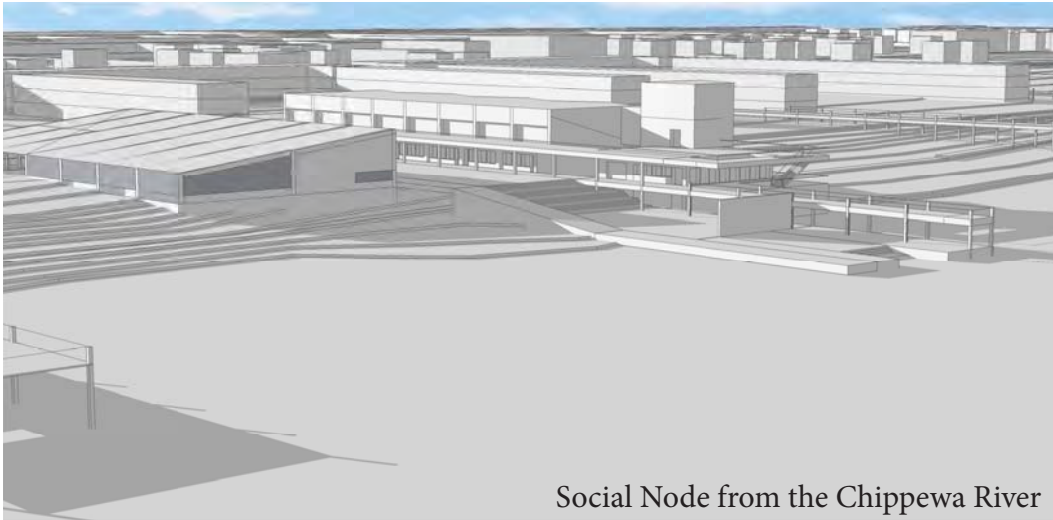

Social Node from the Chippewa River

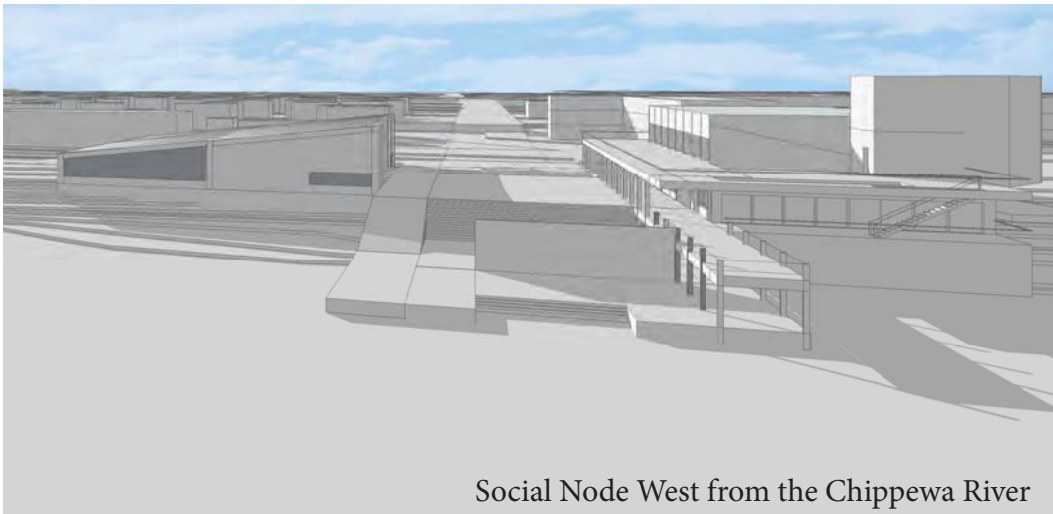

Social Node West from the Chippewa River

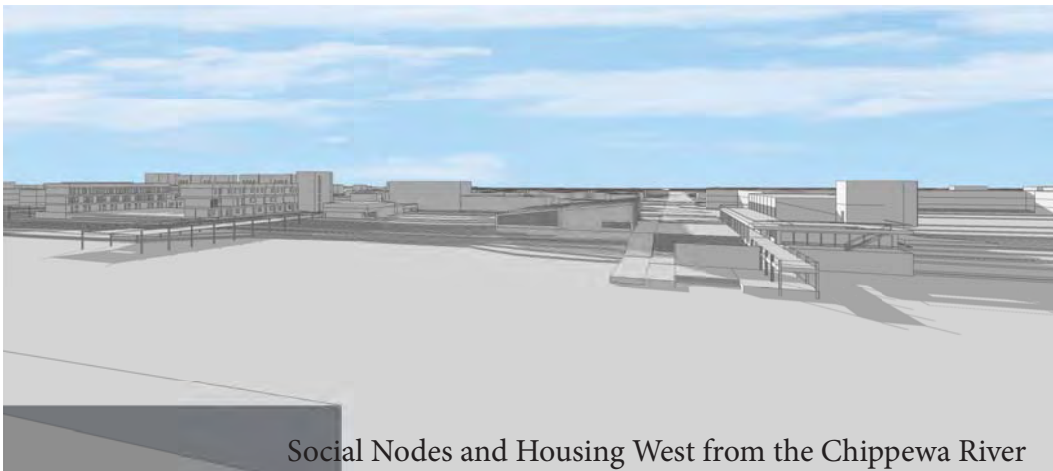

Social Nodes and Housing West from the Chippewa River

HOUSING AND LIVING MACHINE

Beyond the node are clusters of housing surrounding community gardens where residents can interact with each other and their environment. The clusters extend up from the earth, replacing it's footprint in green roofs, some of which are private terraces while others restore patches of the habitat. The clusters are bound to the surrounding neighborhoods by the pedestrian links that draw people into the river. The living machine at the node links the community into the water cycle by creating miniature ecosystems to cleanse the waste water and cycle it back to the buildings for reuse.

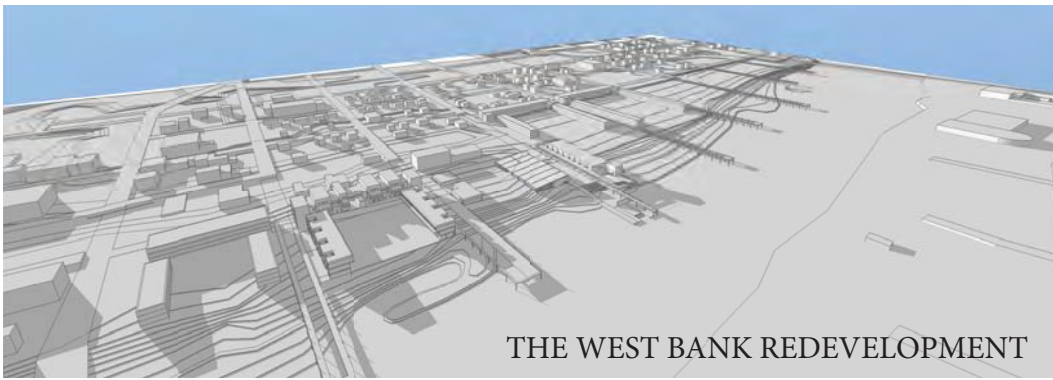

THE WEST BANK REDEVELOPMENT



HOUSING CLUSTER ADJACENT TO COMMUNITY BUILDINGS



HOUSING CLUSTER ADJACENT TO COMMUNITY BUILDINGS

TRANSITION BETWEEN PROGRAM AND PUBLIC/PRIVATE

In order to draw people to the node, Oxford Ave is lined from Madison St. to Platt St. with public program: retail placed below housing and community buildings located adjacent to the Eau Claire Children's Theater bridging housing to the constructed wetlands and living machine.

The wetlands occur at a dip or bowl in the topography and provide a place for runoff water to collect and snow to be plowed out of the way in the winter while simultaneously creating a small ecosystem, contributing to habitat diversity, and bringing the unique sounds and smells of this small ecosystem into the community.

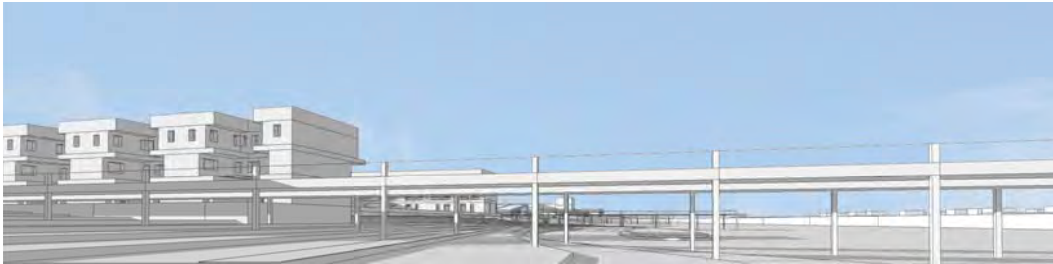

BICYCLE PATH APPROACHING PEDESTRIAN LINK TO RIVER



BICYCLE PATH AT A HOUSING CLUSTER



BICYCLE PATH AT NODE



OXFORD AVE HOUSING AND RETAIL



OXFORD AVE HOUSING AND RETAIL



OXFORD AVE HOUSING AND RETAIL

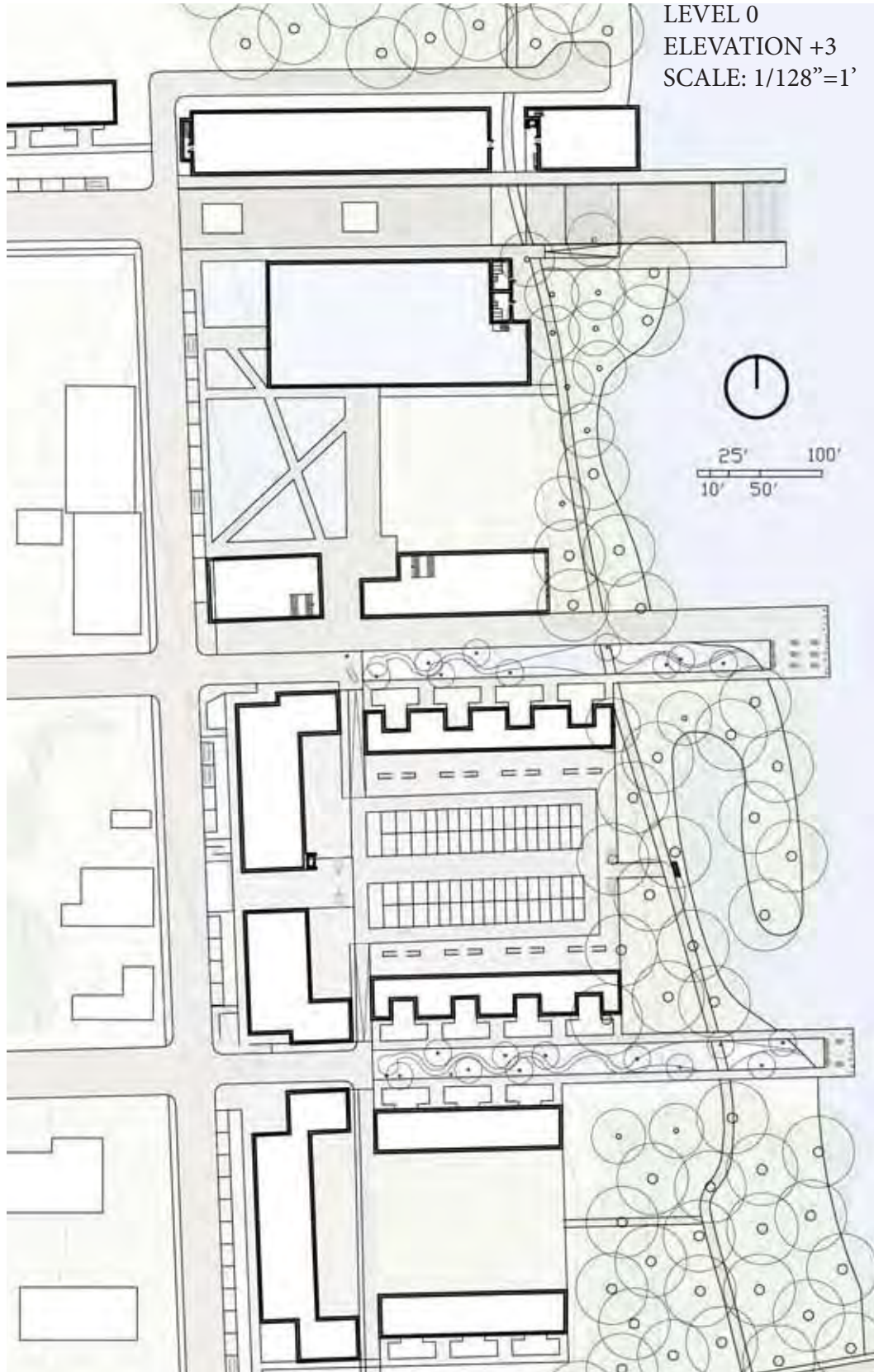

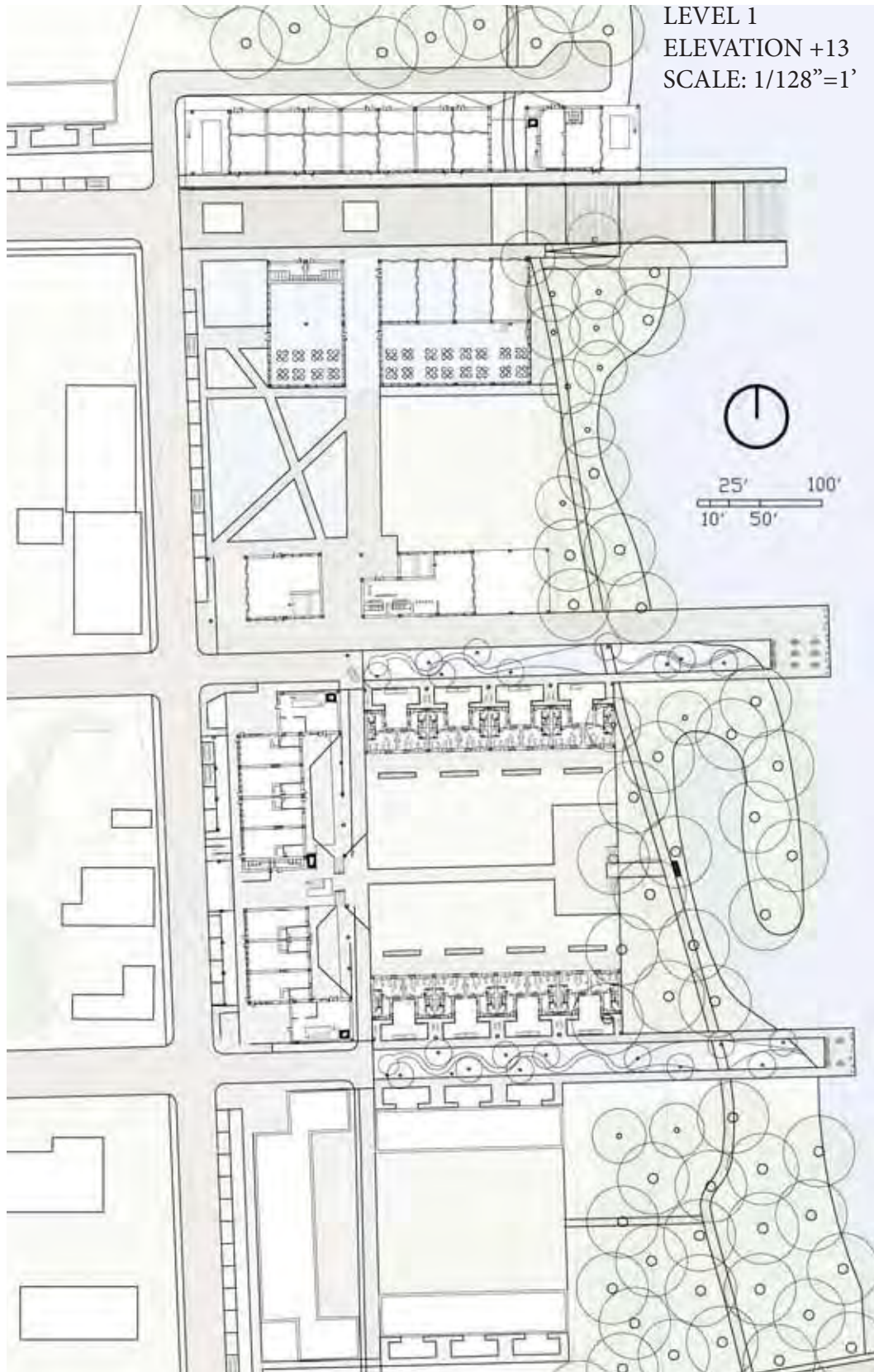

LEVEL 2
SCALE: 1/128"=1'

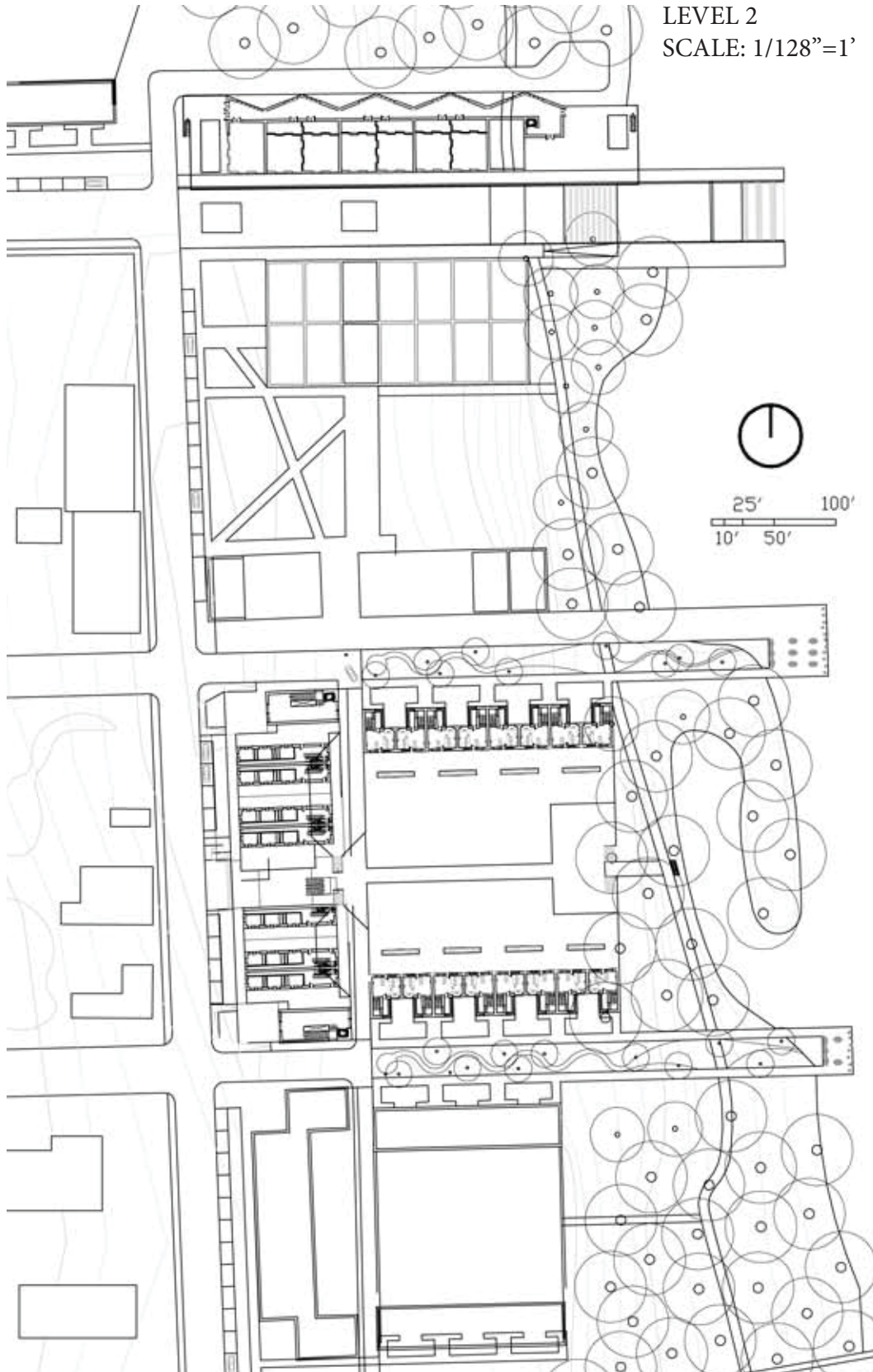

LEVEL 3
SCALE: 1/128"=1'

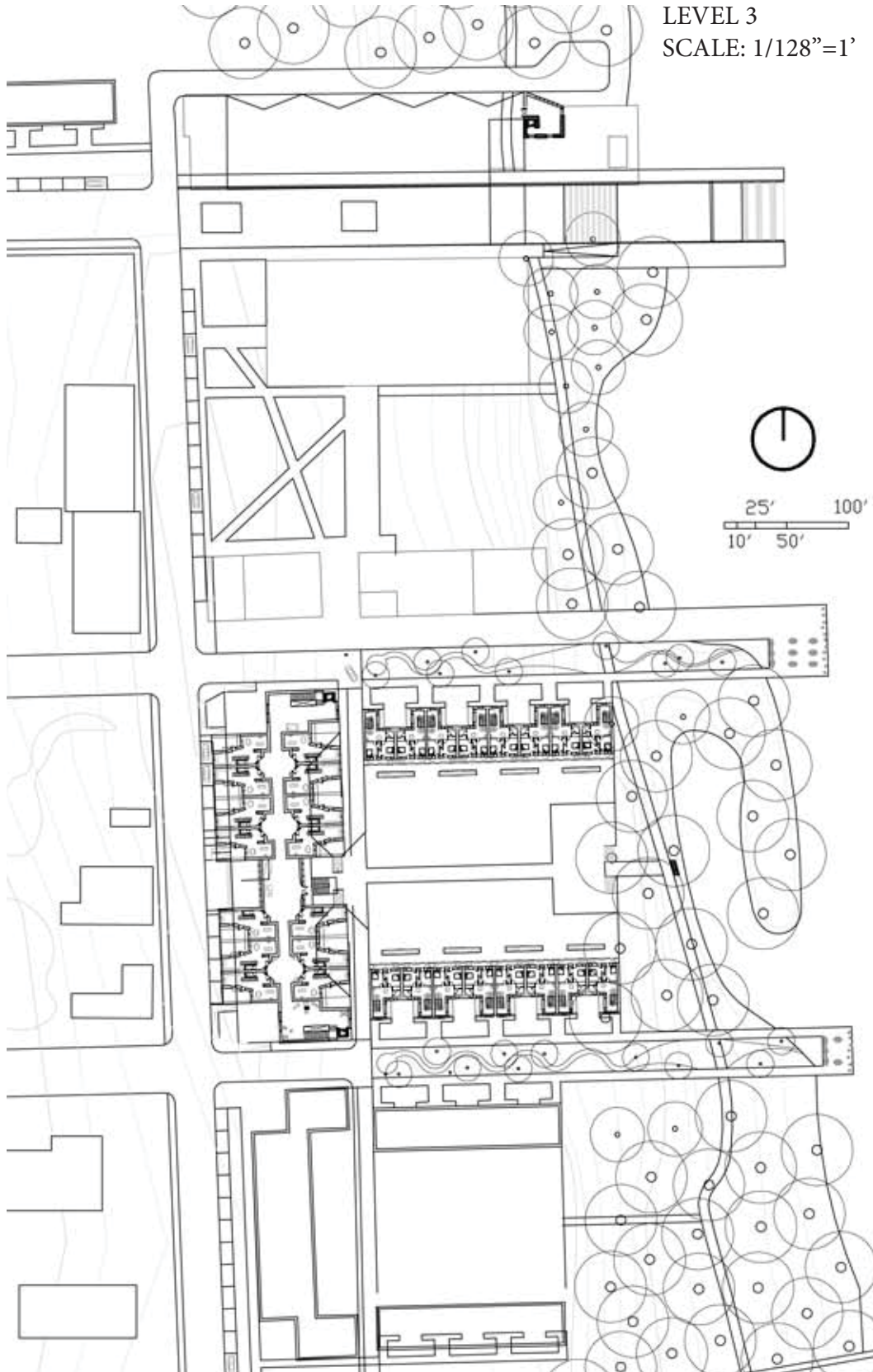

LEVEL 4

SCALE: 1/128"=1'

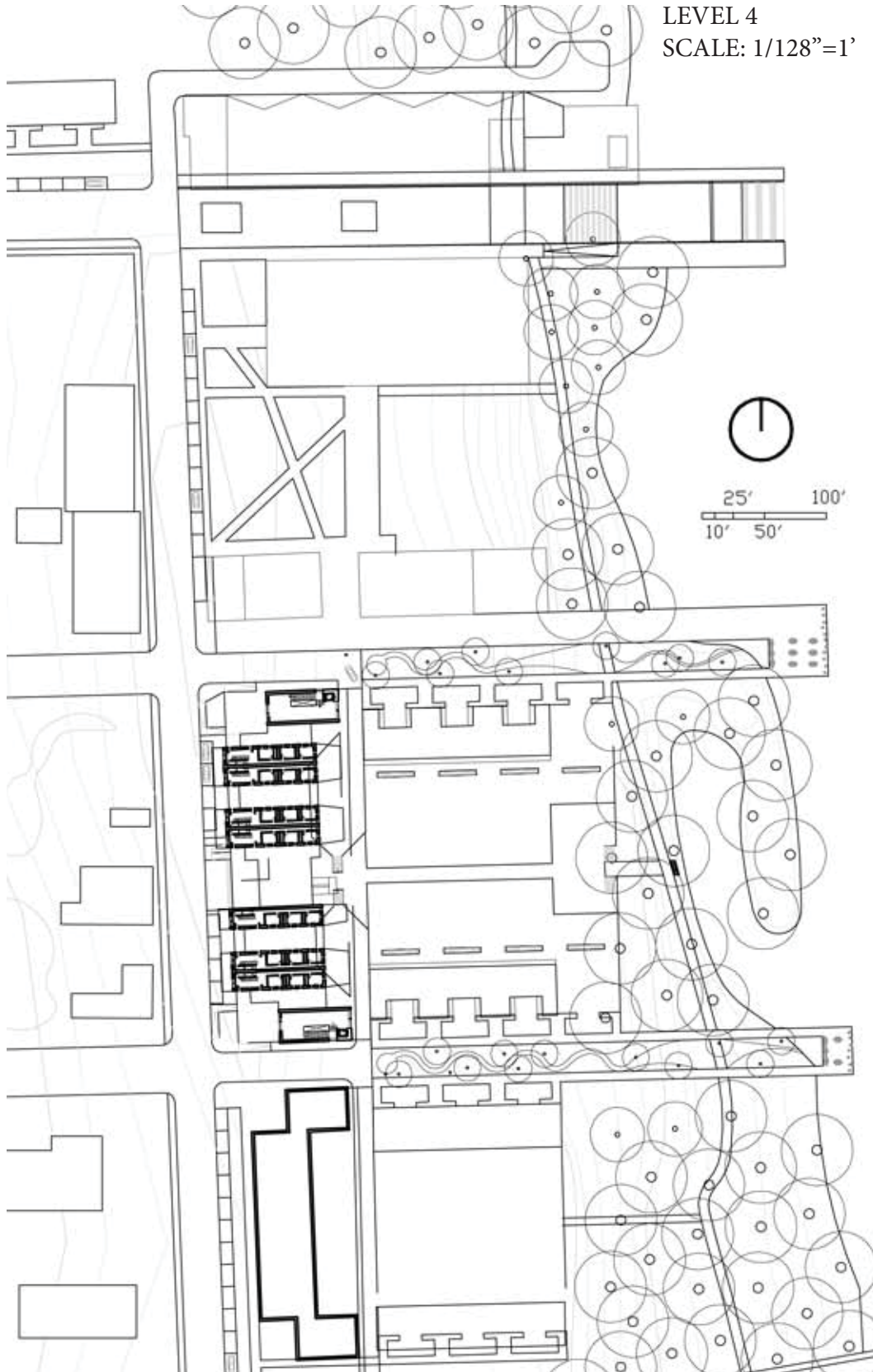

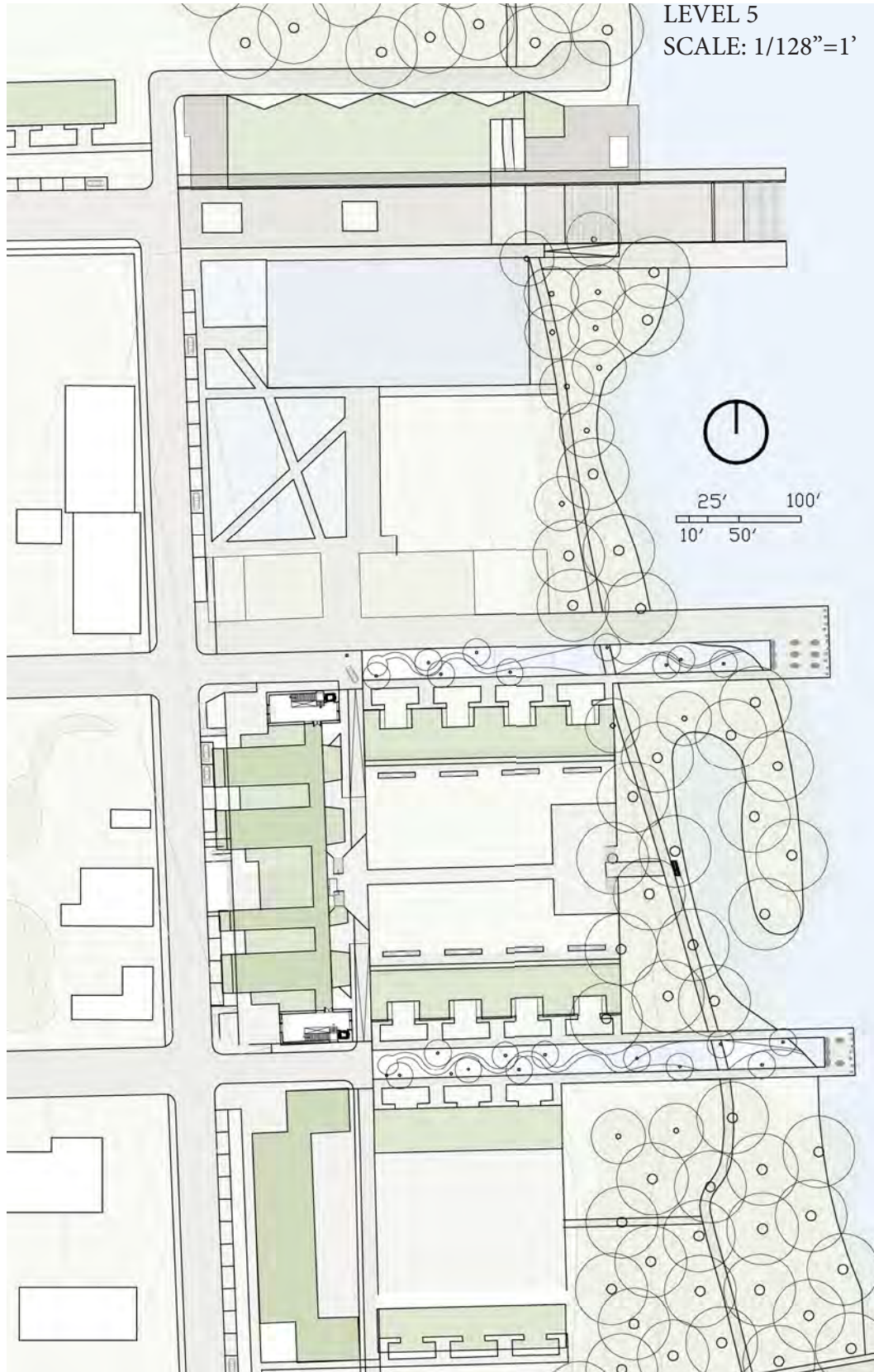



SECTION KEY



SECTION 1

SCALE: 1/128"=1'

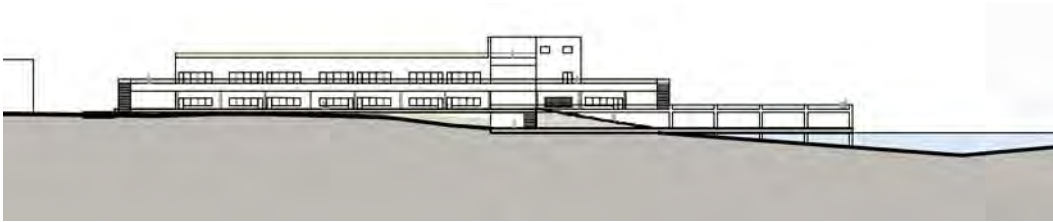

SECTION 2

SCALE: 1/128"=1'



SECTION 3

SCALE: 1/128"=1'



SECTION 4

SCALE: 1/128"=1'



SECTION 5

SCALE: 1/128"=1'

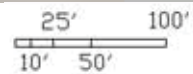

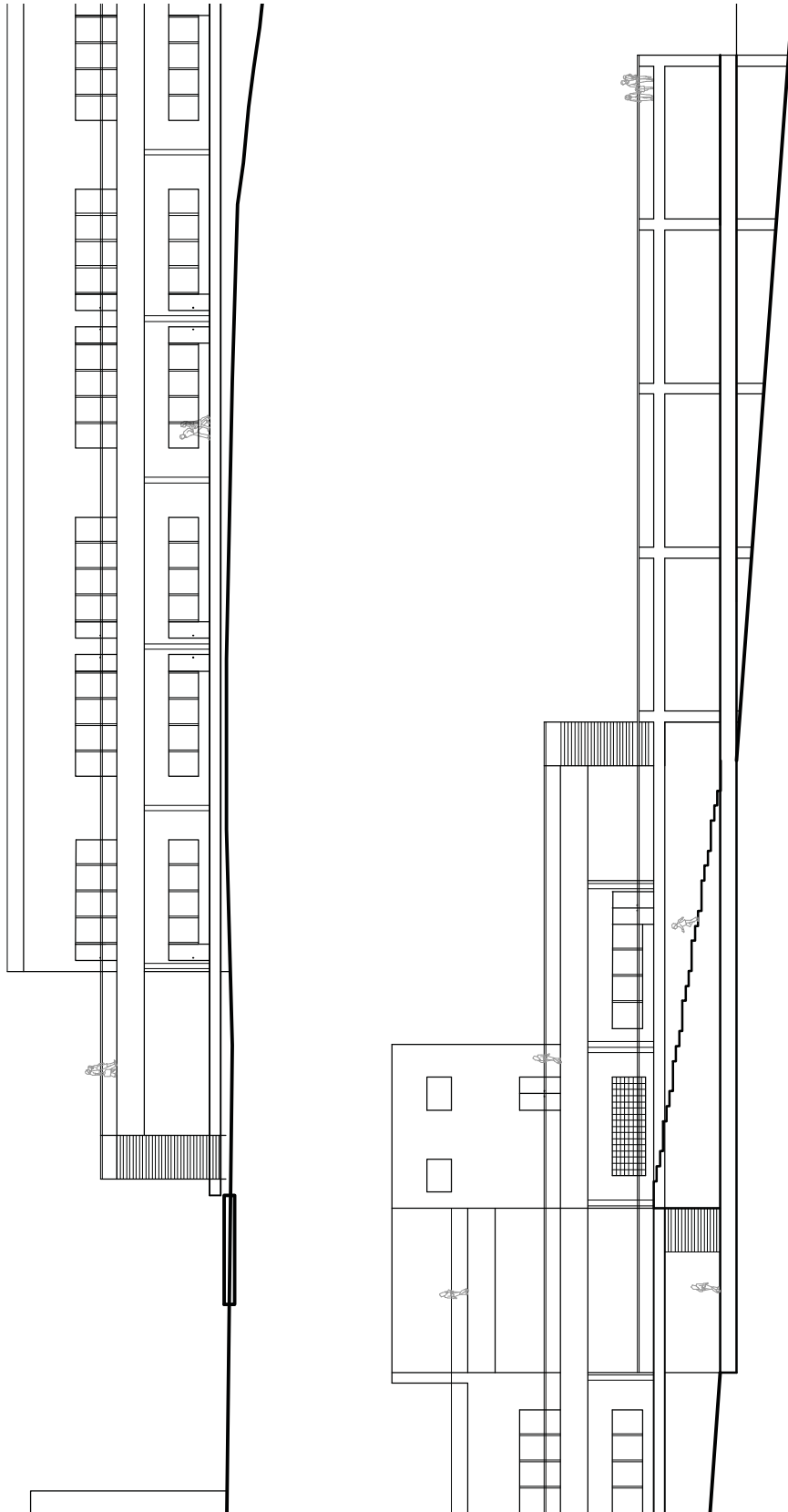

SECTION 2
SCALE: 1/32"=1'

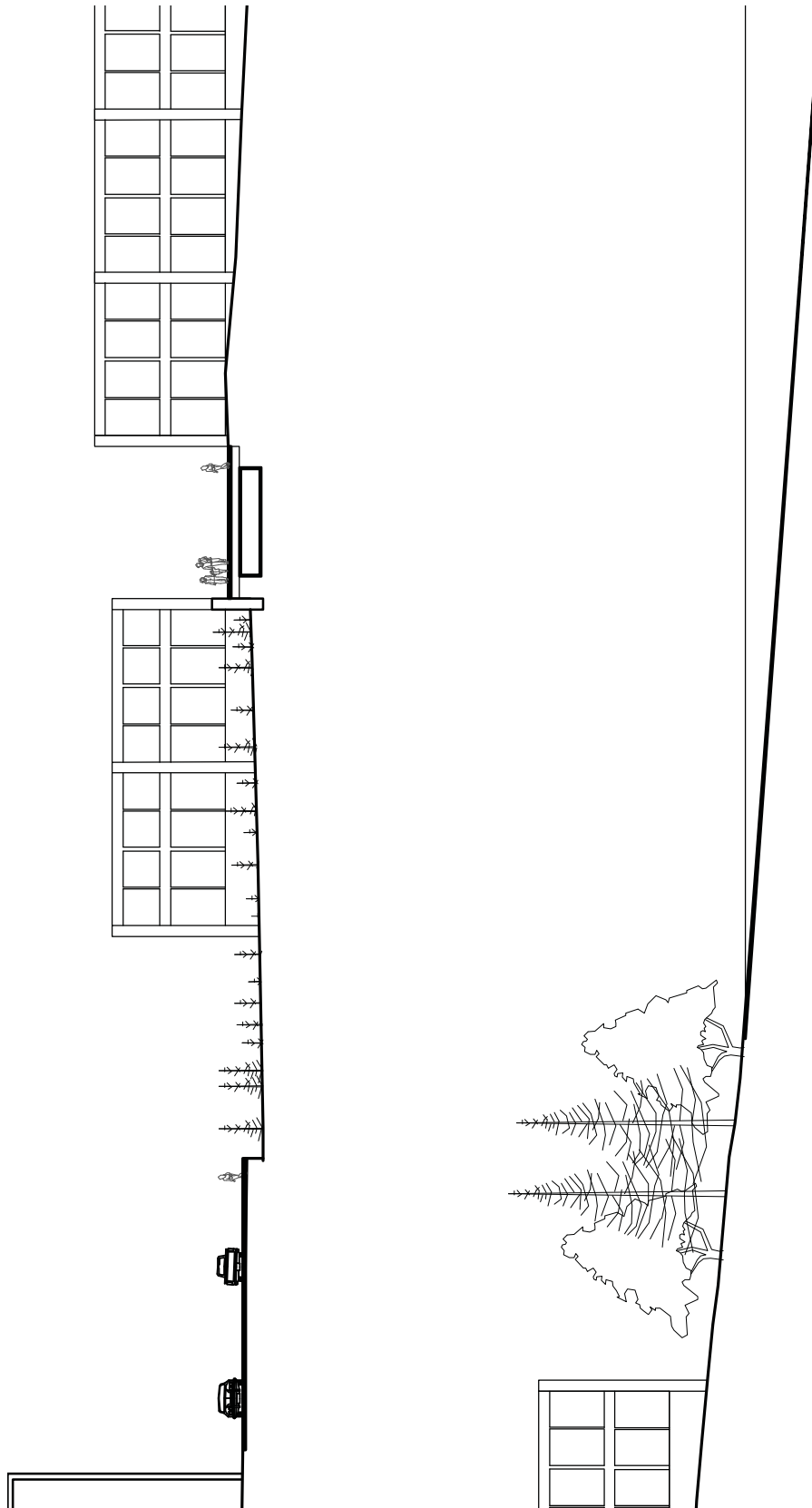

SECTION 3
SCALE: 1/32"=1'

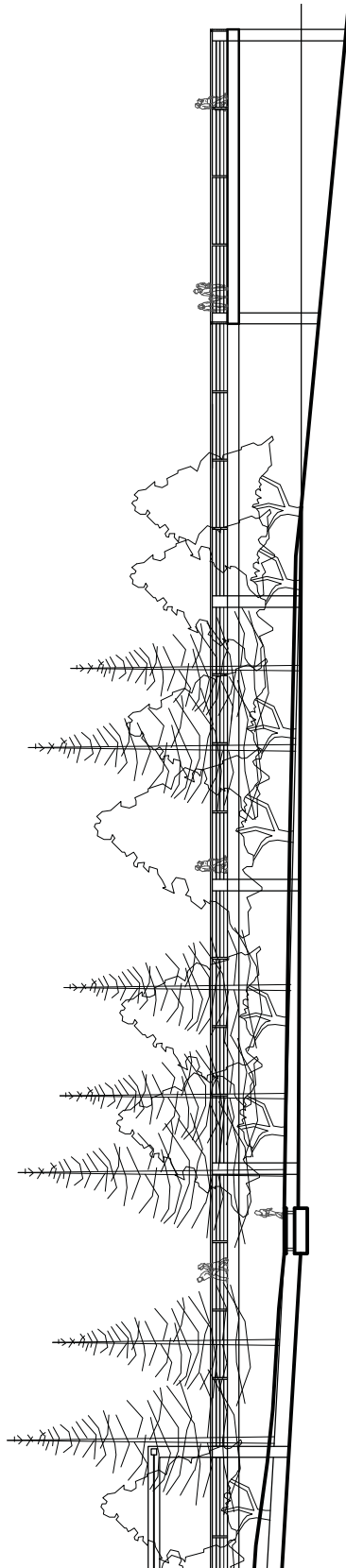
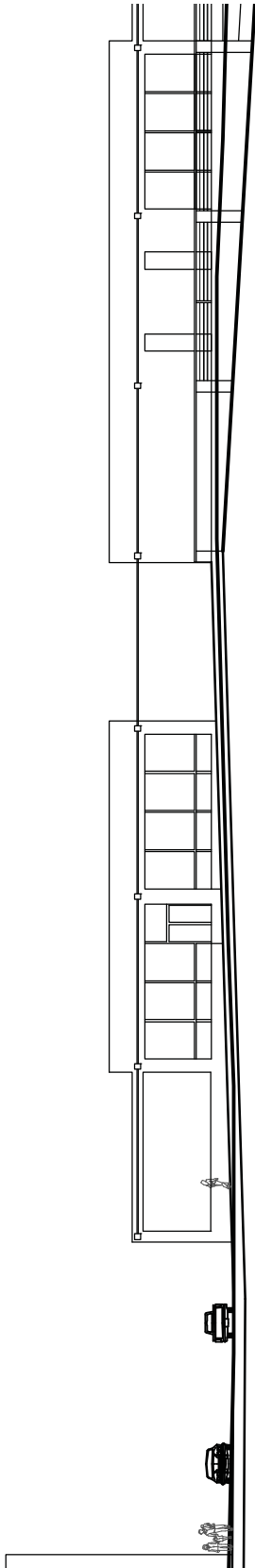

SECTION 4
SCALE: 1/32"=1'

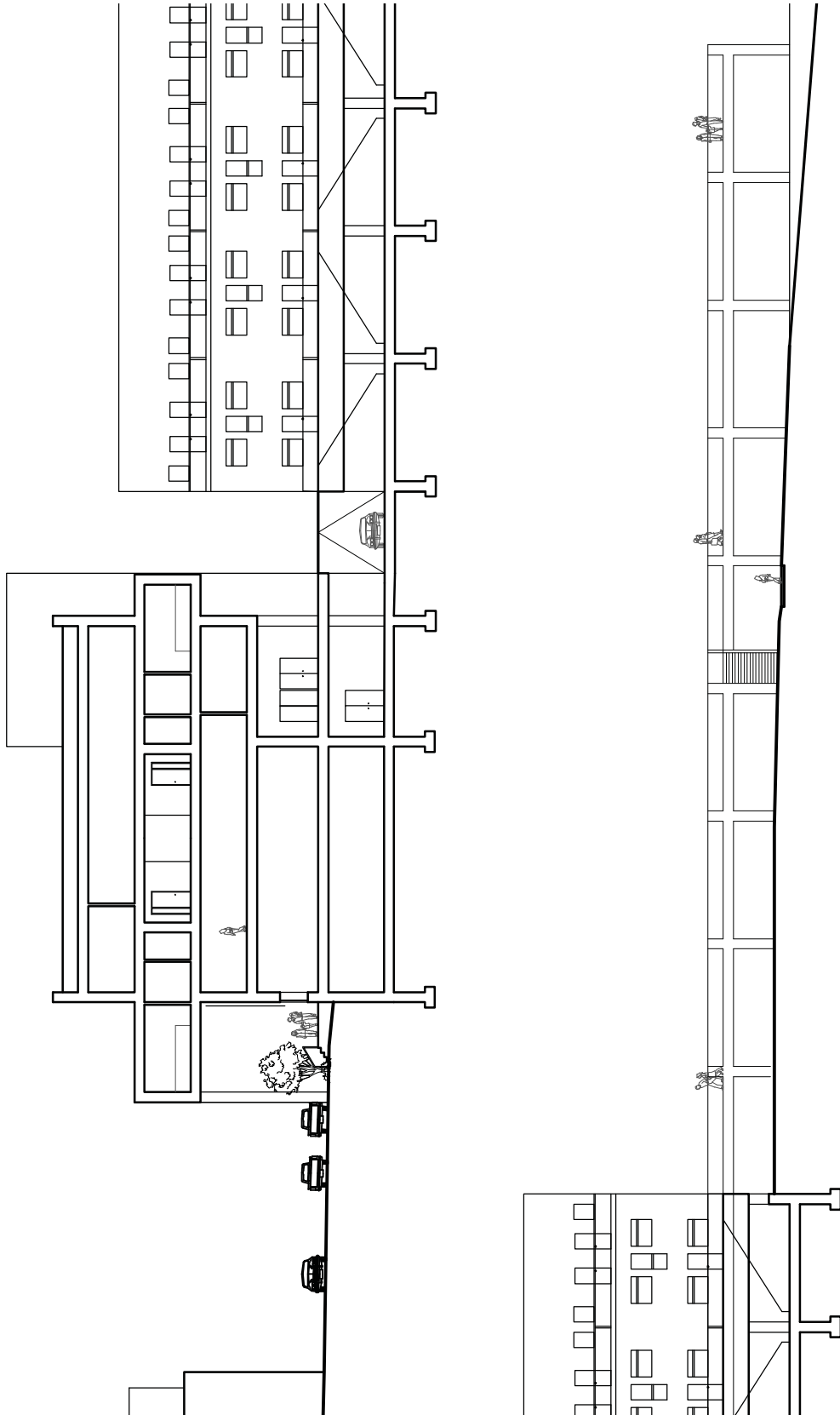

SECTION 5
SCALE: 1/32"=1'



ELEVATION A
SCALE: 1/128"=1'

100'
□

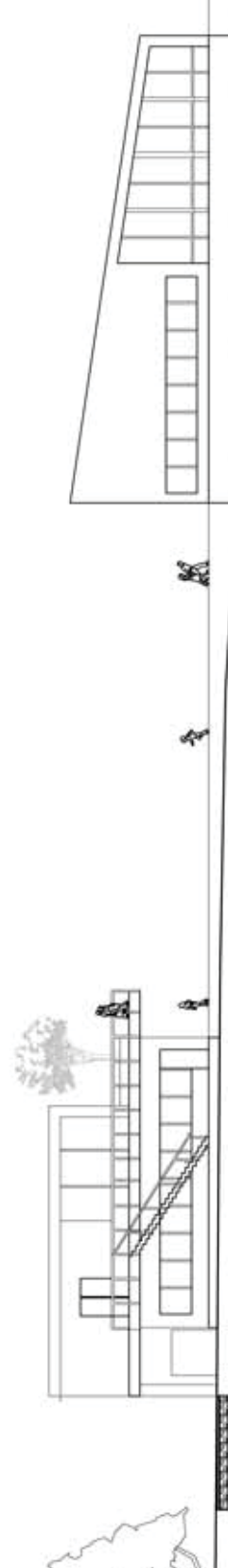

ELEVATION A
SCALE: 1/32"=1'

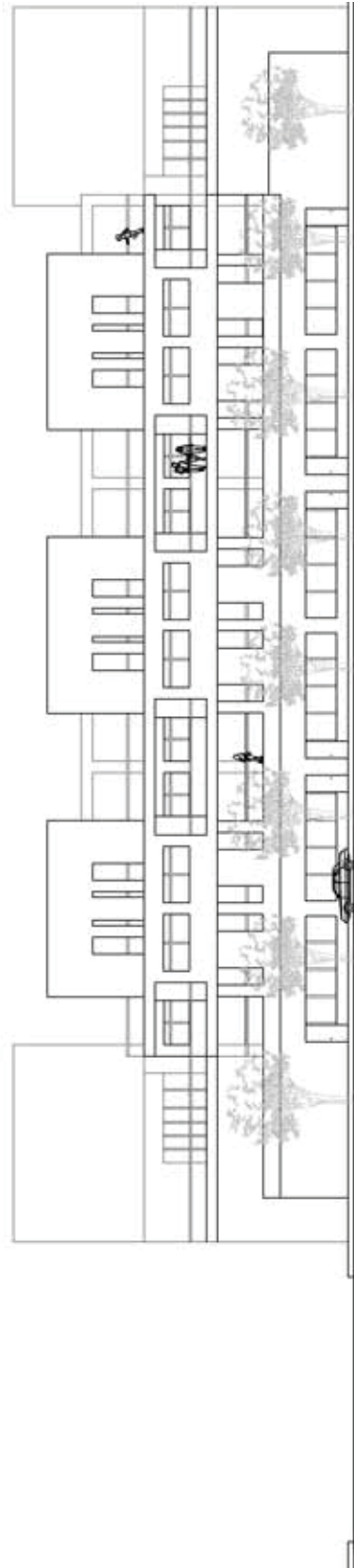
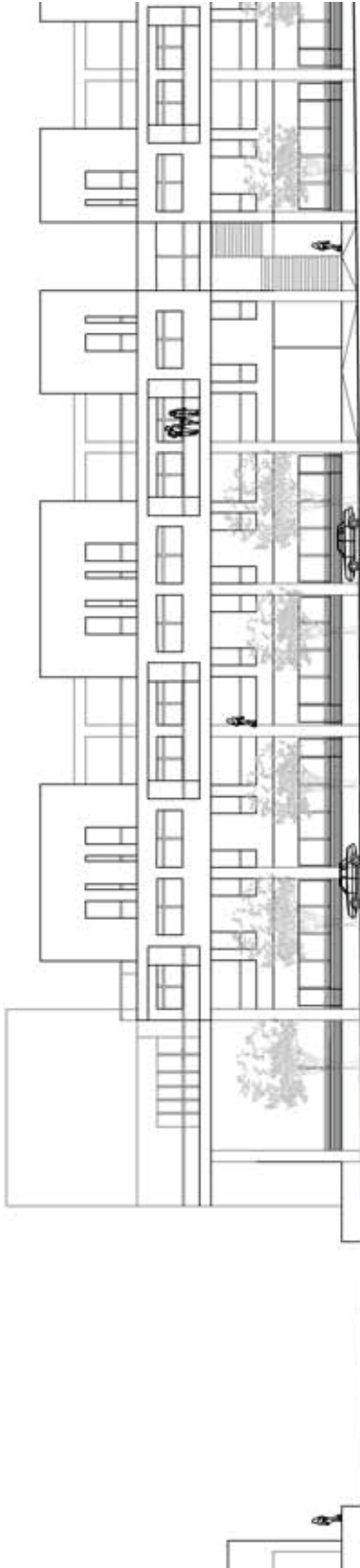

ELEVATION A
SCALE: 1/32"=1'



SECTION B
SCALE: 1/128"=1'

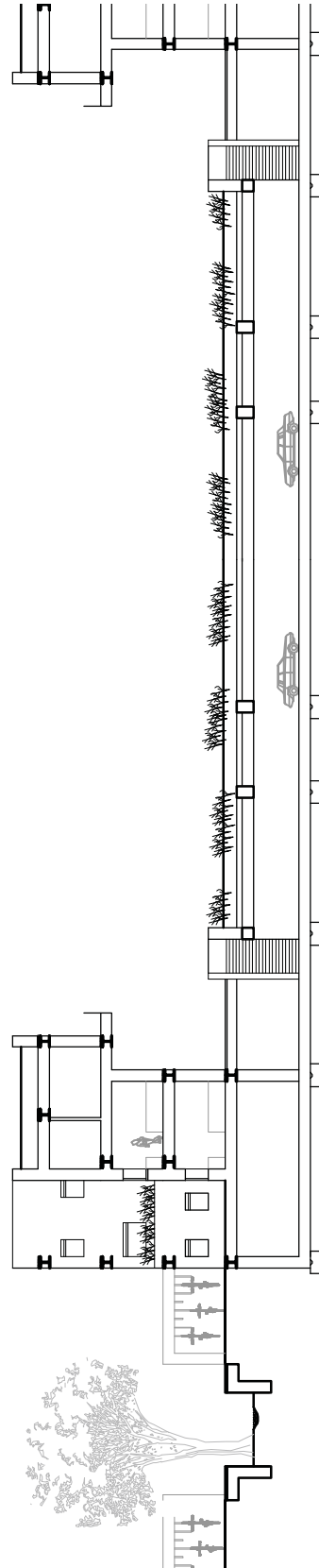

SECTION B
SCALE: 1/32"=1'

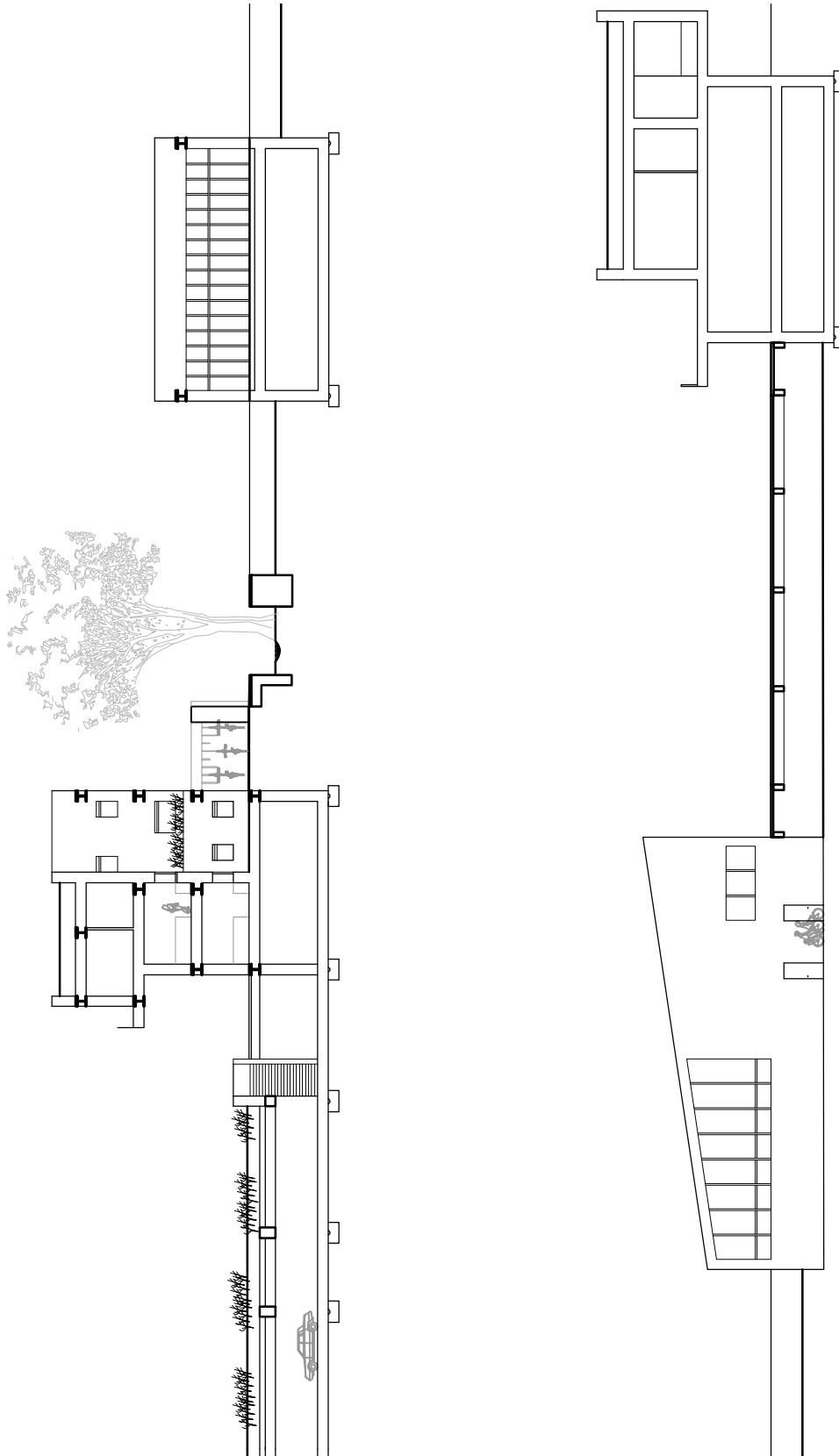

SECTION B
SCALE: 1/32"=1'

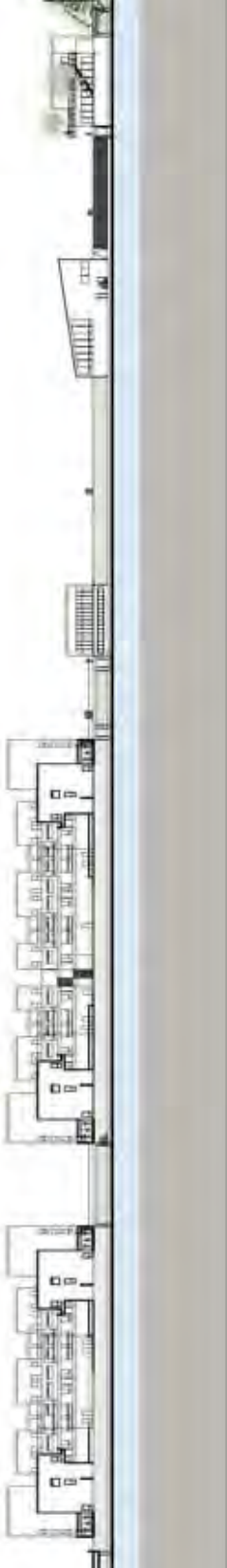

ELEVATION C
SCALE: 1/128"=1'

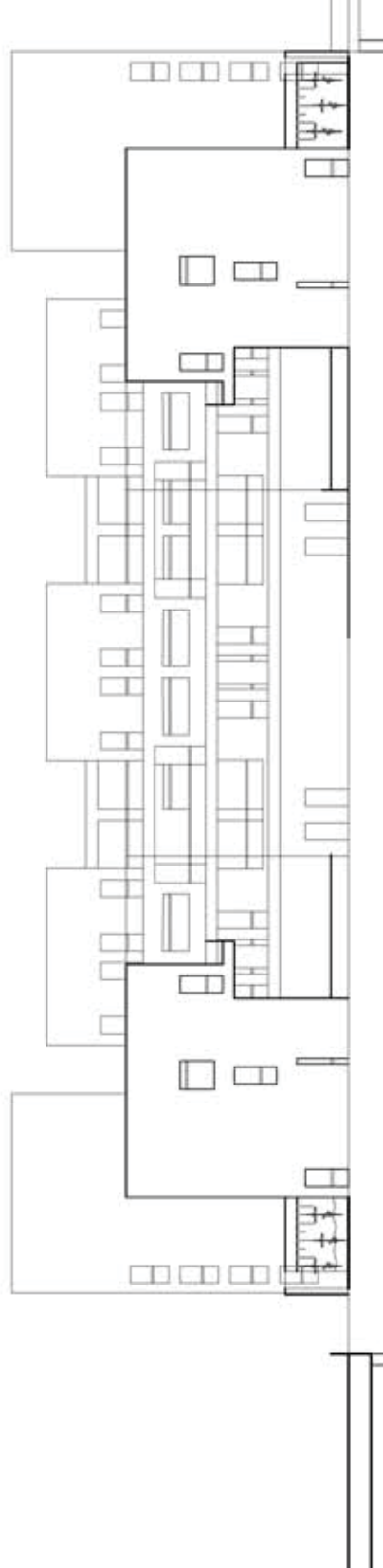

ELEVATION C
SCALE: 1/32"=1'

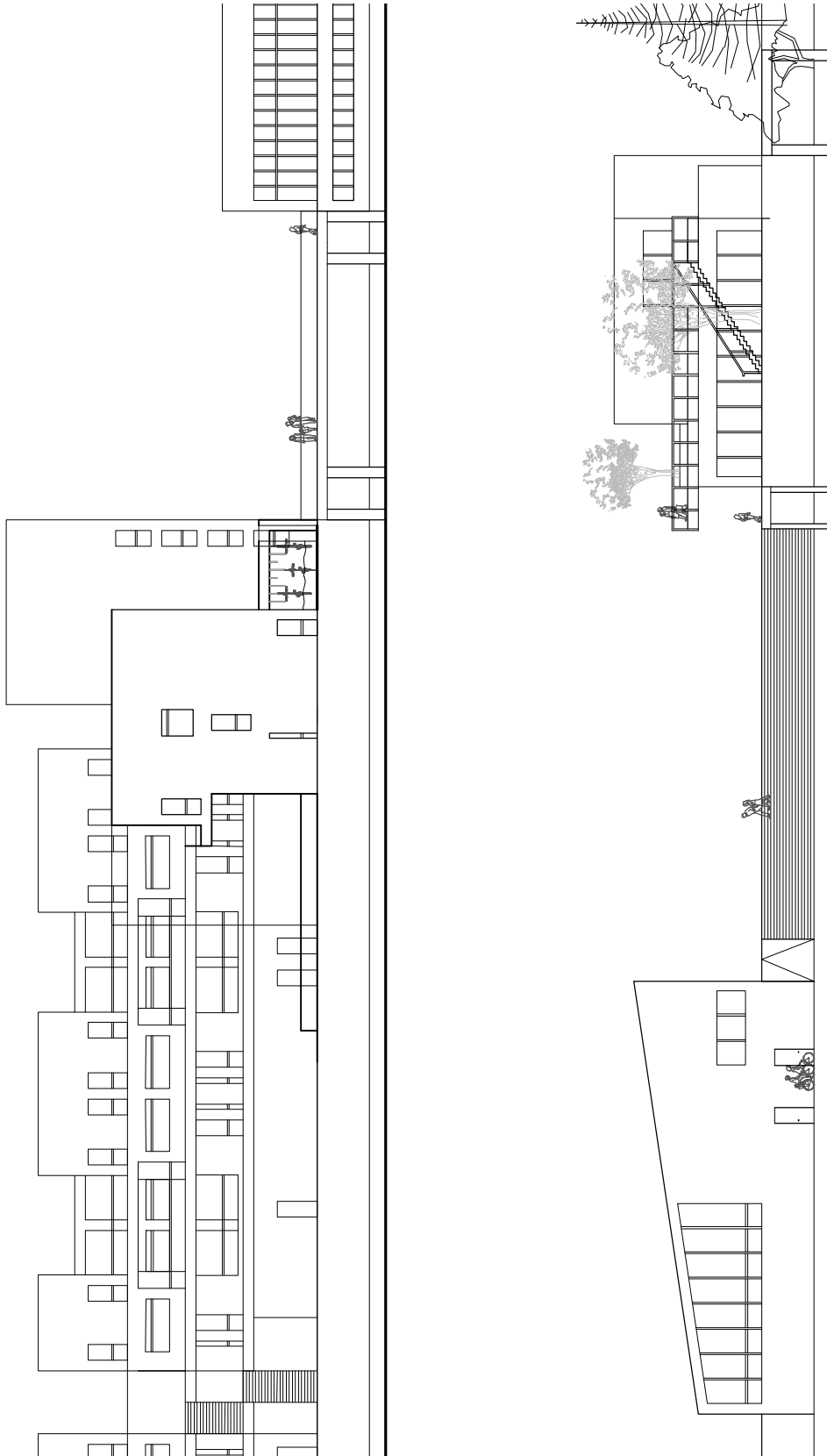

ELEVATION C
SCALE: 1/32"=1'



 CHIPPEWA RIVER

 DESIGN

 PUBLIC

 PRIVATE

FINAL MODEL





FINAL MODELS

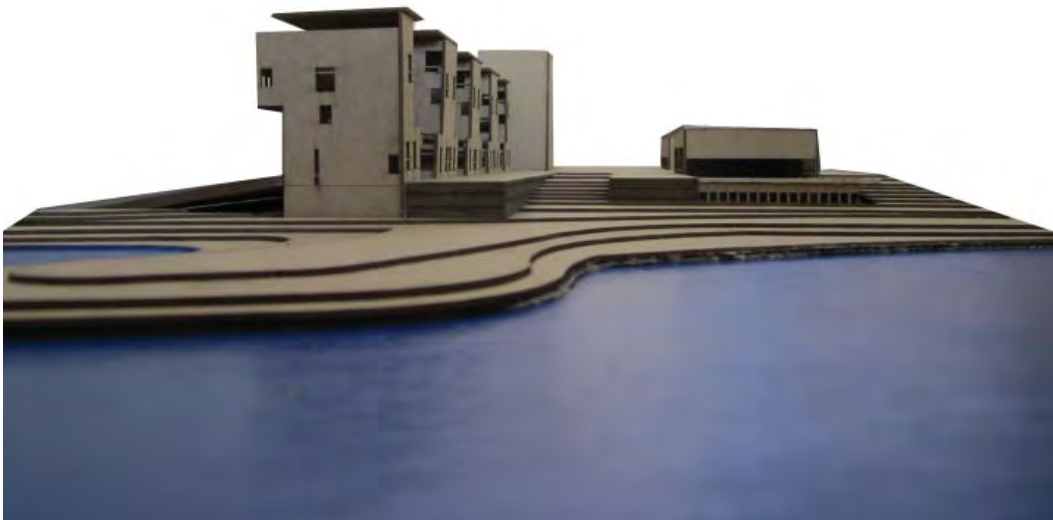

REVIEW 1
Tuesday February 22, 2011

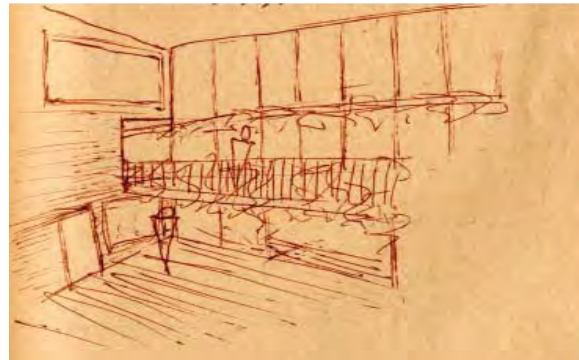
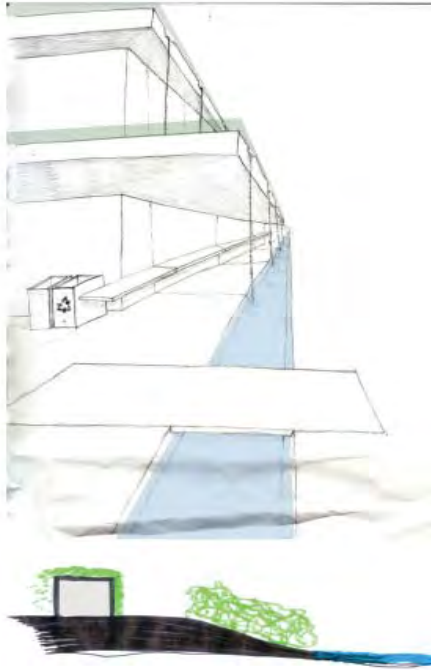

Chain leaders can provide a visually interesting means of bringing water from roof to swale. Seating along the swale, particularly in public areas such as the plaza, encourage people to linger.

Facades facing the greenbelt should be more heavily vegetated, for example with living walls. Green roofs should also be provided both for activity and habitat.

Bringing the structure beyond the building to encompass pathways extends the space and blurs the line between indoor and outdoor.

Covered bicycle parking along the bike path encourages the use of bicycles. Amenities such as seating, a drinking fountain and plantings may also be provided.

Natural ventilation provides an opportunity at air intake locations such as windows and doors for scented plantings to be strategically located.

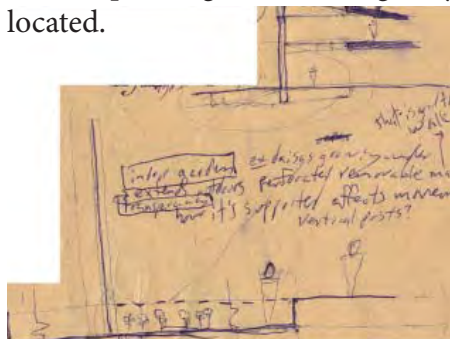
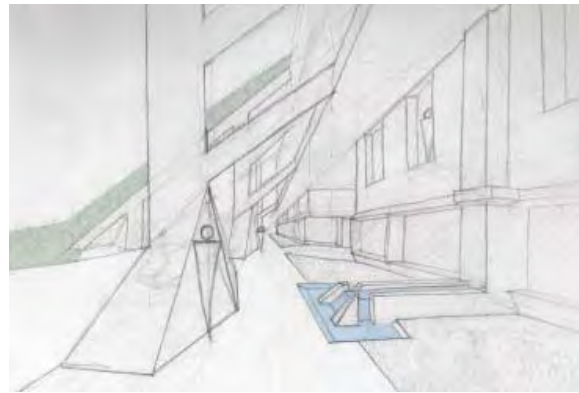

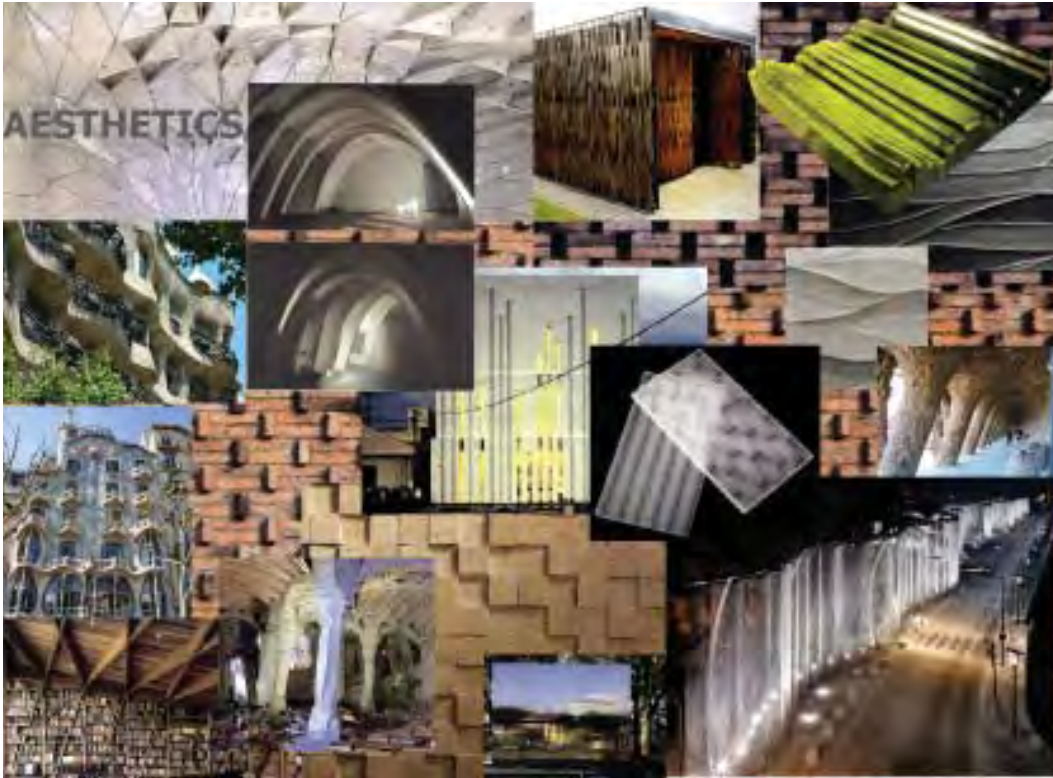

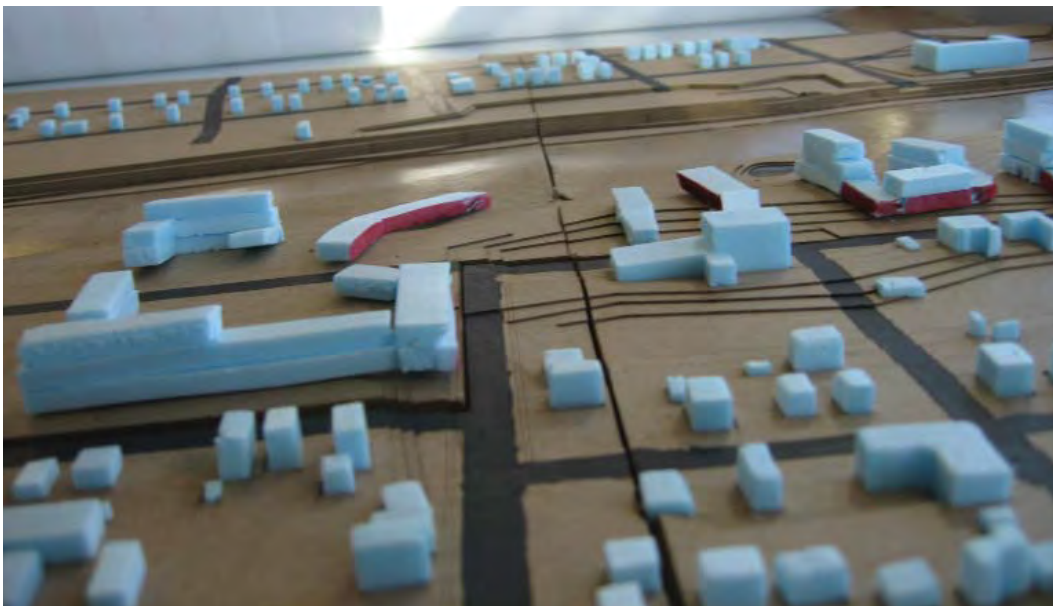

SCHEME 1



SCHEME 1

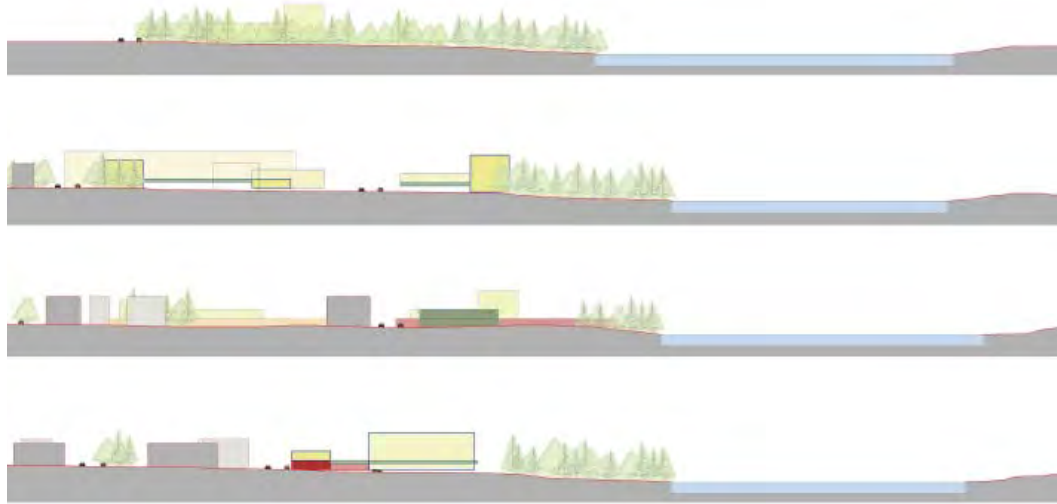

Creating a retail plaza that connects people to the water generates greater interaction and strengthens the connection between the West Bank, Phoenix Park and Downtown. I have located this plaza that steps down to a performance space and dock at the river's edge along a major path of circulation at the corner of Oxford Ave and Platt St and adjacent to the Eau Claire Children's Theater. The living machine is located in this plaza. Retail and offices front these streets drawing people in to the plaza. Above and behind the retail are housing units. A green roof covers the parking while providing a place for outdoor activity and views for the residents. A community garden provides an opportunity to grown one's own garden, be it for food or flowers, and to interact with neighbors both living on- and off-site.

SCHEME 2

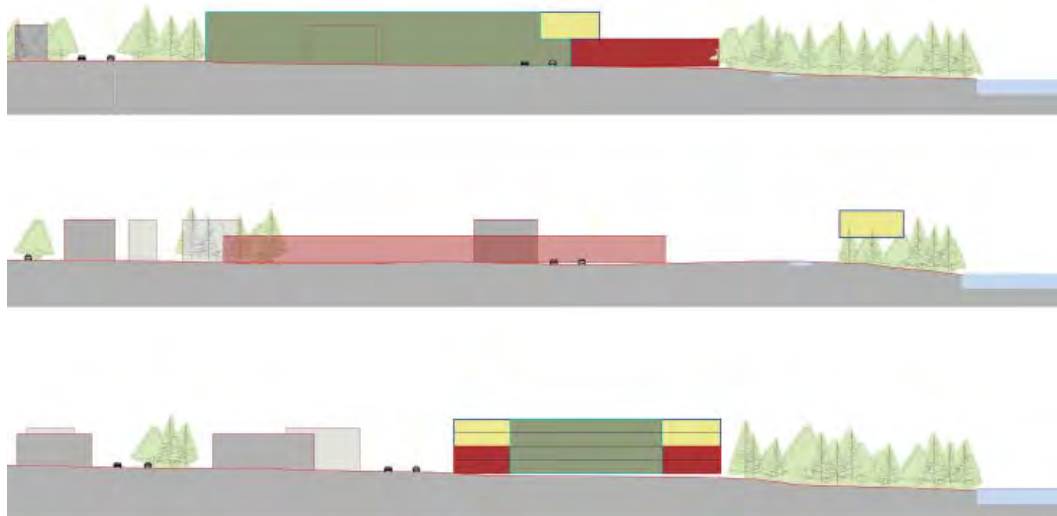

SCHEME 2



REVIEW 2

Tuesday March 25, 2011









LEVEL 1 PLAN _____ 1/32"=1'



LEVEL 2 PLAN _____ 1/32"=1'



LEVEL 3 PLAN _____ 1/32"=1'

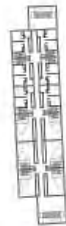

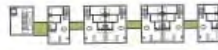

LEVEL 5 PLAN _____ 1/32"=1'



BRIDGE OF FLOWERS
SHELburn FALLS, MA

PRECEDENT FOR COMMUNITY GARDEN BRIDGE



LEVEL 6 PLAN _____ 1/32"=1'

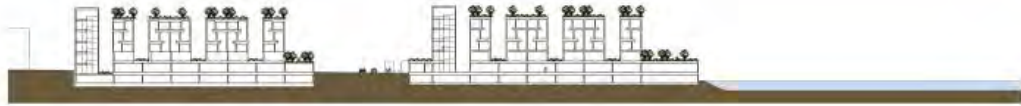

SECTION A _____ 1/32"=1'



SECTION B _____ 1/32"=1'



SECTION C _____ 1/32"=1'



SECTION D _____ 1/32"=1'



SECTION E _____ 1/32"=1'

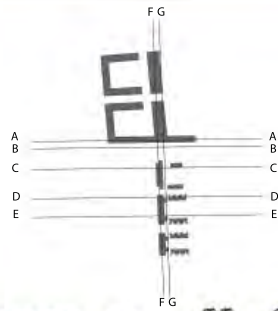

SECTION F _____ 1/32"=1'



SECTION G _____ 1/32"=1'

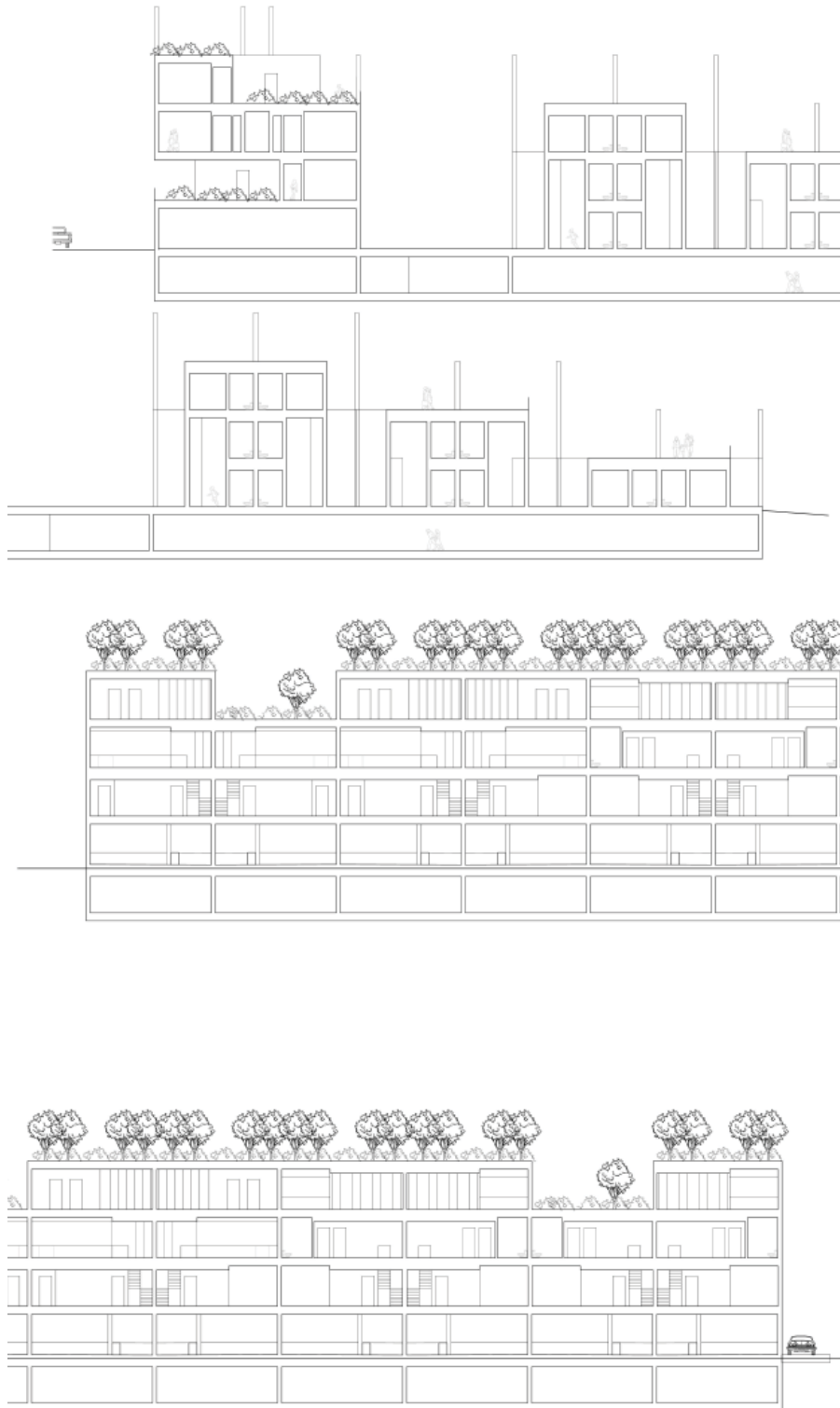



LEVEL 5

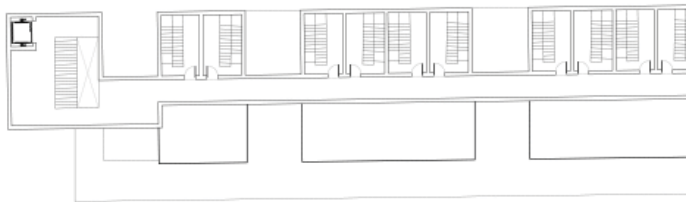

LEVEL 4



LEVEL 3

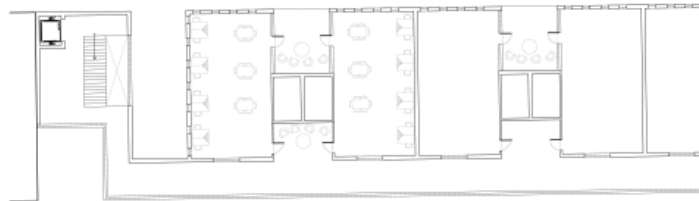

LEVEL 2

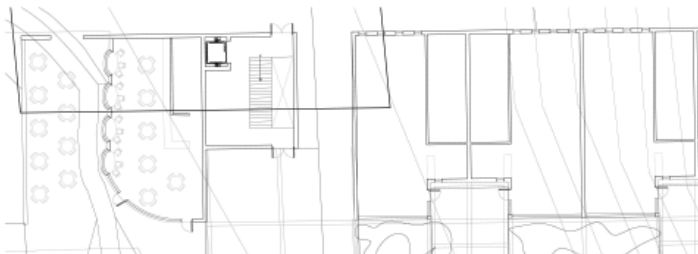

LEVEL 1

NODE BAR _____ 1/8"=1'



LEVEL 1



LEVEL 2

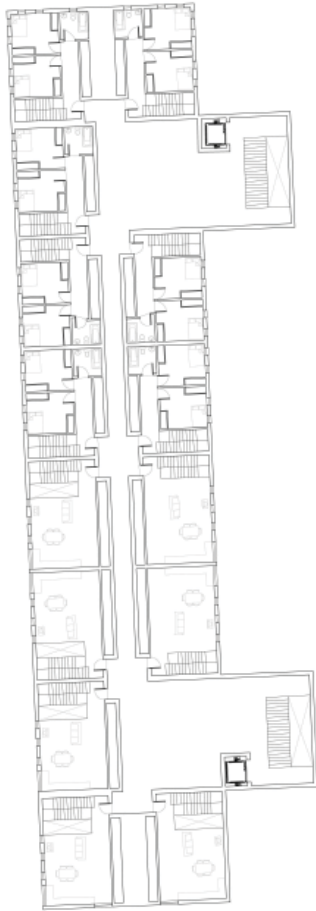

LEVEL 3



LEVEL 4

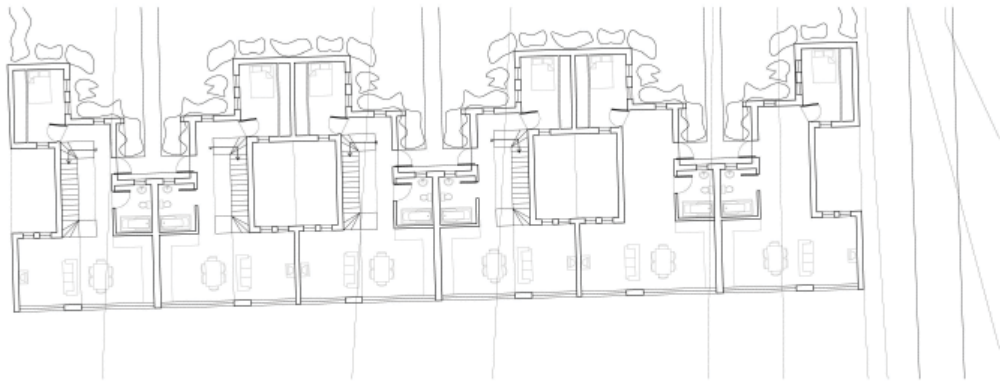
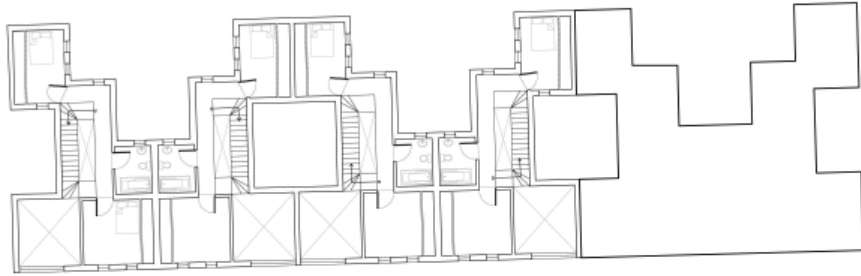
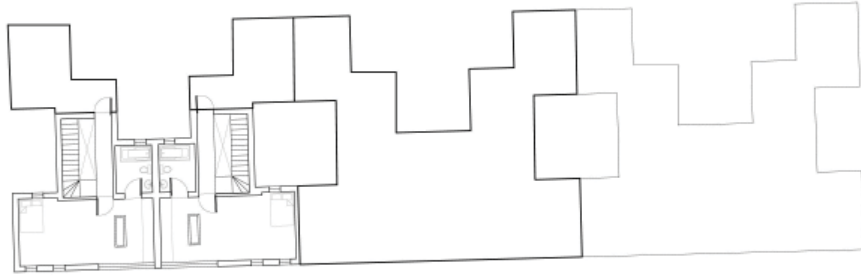



WINDOW DETAIL

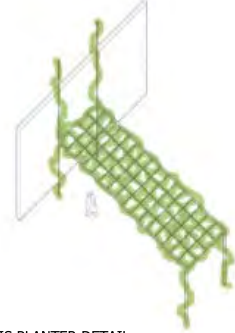

TRELLIS PLANTER DETAIL

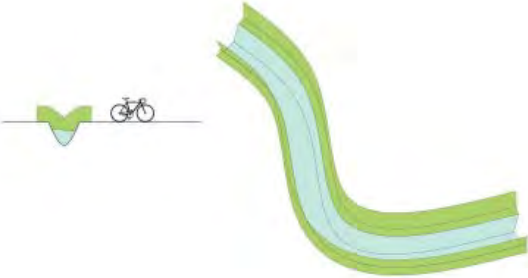

BIKE PARKING AND SWALE DETAIL

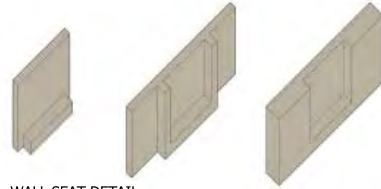

WALL SEAT DETAIL

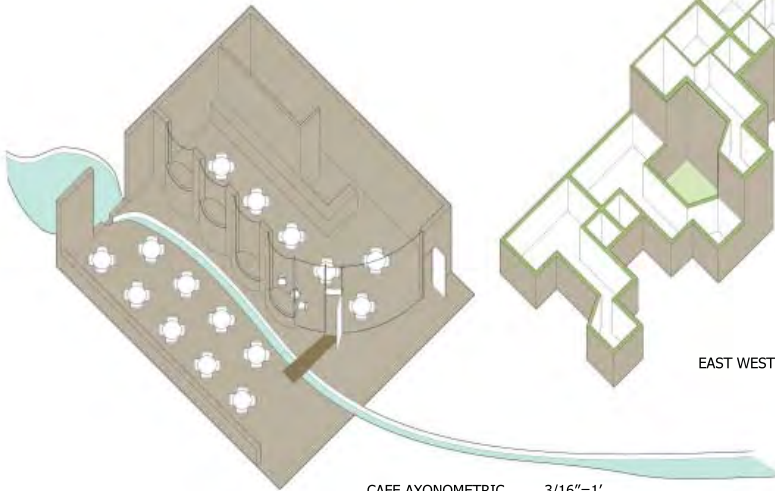

CAFE AXONOMETRIC _____ $3/16''=1'$

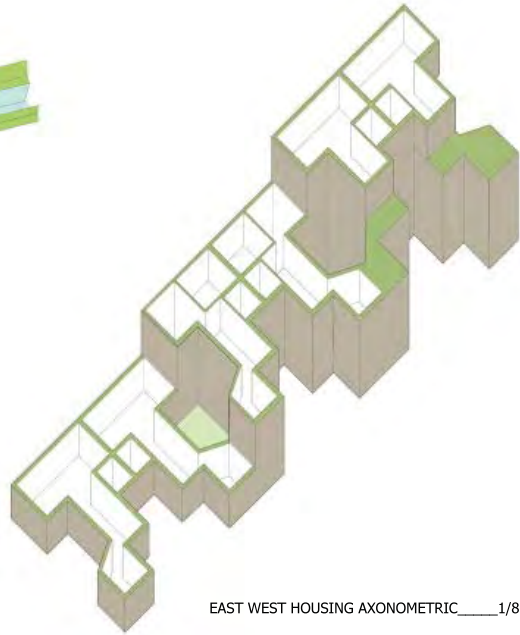

EAST WEST HOUSING AXONOMETRIC _____ $1/8''=1'$

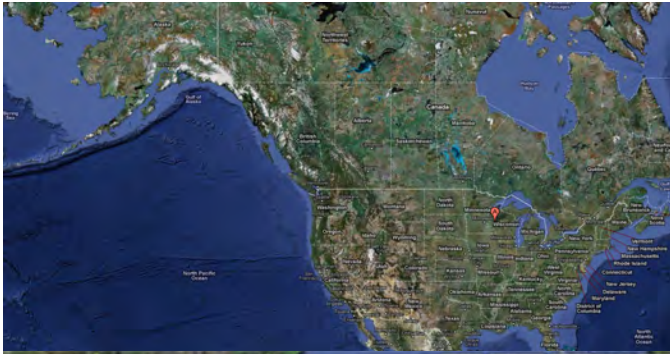

UNITED STATES OF AMERICA



WISCONSIN



EAU CLAIRE



WEST BANK
REDEVELOPMENT

Site Area: 40 Acres

Located to the west of the
Chippewa River from North
Barstow Downtown

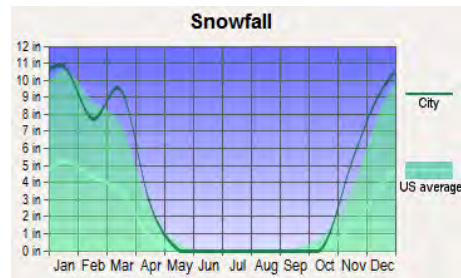
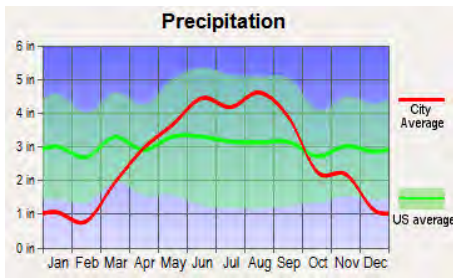
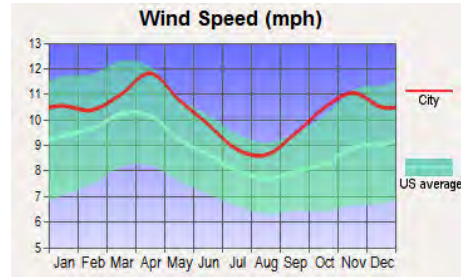
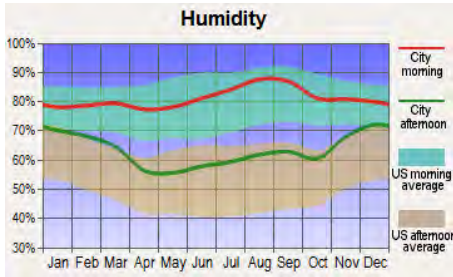
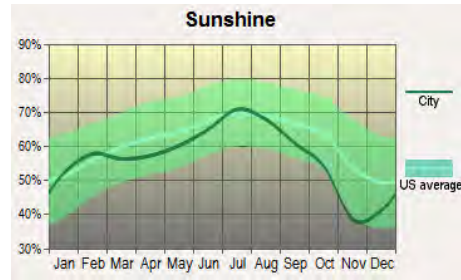
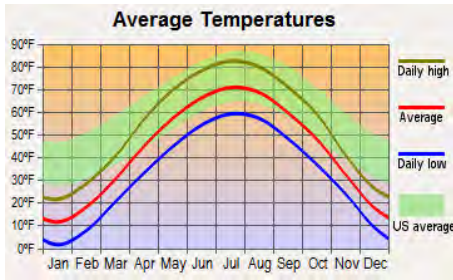

Month	Average Speed	Prevailing Wind
Jan	9.9	WSW
Feb	9.8	WSW
Mar	10.9	ENE
Apr	12.1	NE
May	11.3	NE & S
Jun	10.2	S
Jul	9.0	S
Aug	8.7	S
Sep	9.4	S
Oct	10.0	S
Nov	10.7	WSW
Dec	9.9	WSW
Annual	10.1	WSW

The climate will necessitate heating in the winter and cooling in the summer.

The amount of sunshine allows for the application of passive and active solar heating.

Humidity affects comfort levels. High humidity in the summer coupled with high temperatures will increase the importance of cooling in the summer. Passive systems should be explored.

High wind speeds in the winter will require a design that blocks the wind to aid in comfort levels. Evergreens could be used for this application.

High levels of precipitation in the summer months makes water runoff a strong influence in site design. Swales and retention ponds can aid in this. Green roofs may also reduce runoff.

High levels of snowfall will increase roof loads in the winter months. Plough areas will also have to be taken into consideration in the design of the site.

Dominant winds:

Winter: WSW Spring: NE Summer: S

Population in July 2008: 65,426

Population change since 2000: +6.0%

Green patches exist in Eau Claire that present the possibility of **extending the habitat into the city** through environmental design.

The site is located in downtown Eau Claire, Wisconsin along the Chippewa River and adjacent to single- and multi-family housing. Downtown is broken into four districts. On the east bank is the Historic District and North Barstow and on the west bank is the Courthouse District, the Hospital District, and the site. The University of Wisconsin Eau Claire is within biking distance to the south. Chippewa Falls Regional Airport is located no more than a 15 minute drive north of Downtown Eau Claire.

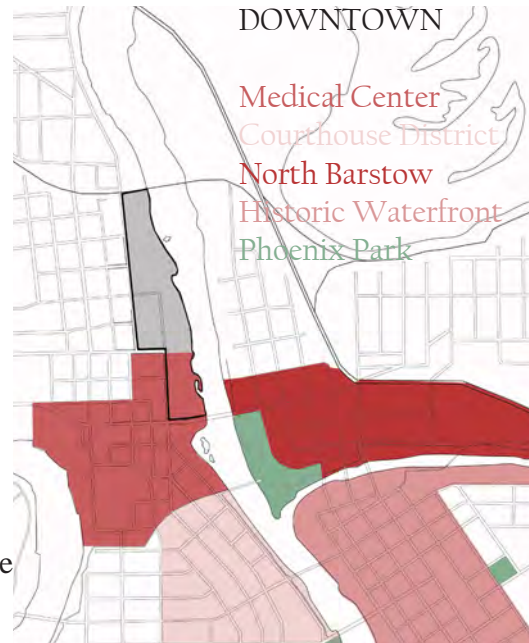

Just south and across the river from the West Bank Redevelopment is the North Barstow Redevelopment Area which is nearing completion. By redeveloping the West Bank, connections may be made to downtown which will create a vibrant community atmosphere. The values that were important for the North Barstow Redevelopment thus also apply to the West Bank.

“The North Barstow Redevelopment Area has become a priority for several reasons. The feedback from our residents was to **create a park along the river and to link the bike and riverfront trail system**. The North River Fronts Neighbourhood Association is interested in cleaning up the blight in their neighbourhood. The community wanted more **restaurants and cafes facing the river and more opportunities for housing in the downtown**. And last, but not least, the private sector has shown interest in investing their money into revitalization of this area.

One of the goals of this plan is to **generate more activity in the downtown, 24 hours a day, by encouraging people to live, work and use the parks and trails. This people activity will support existing retail and create additional retail opportunities.”**¹

¹ “North Barstow Redevelopment Area”, City of Eau Claire, 1872-2009. date accessed: 4/17/2010. <http://www.ci.eau-claire.wi.us/city-manager-home/971-north-barstow-redevelopment-area>

Buildings in the area which promote residential, retail and office design

Public schools

Attracts families

University of Wisconsin-Eau Claire

Attracts students

Attracts professionals seeking continuing
education

Attracts businesses to support college life & jobs for recent alumni

Daycare

Attracts families with small children

Attracts new families

Hospitals

Promotes security

Attracts elderly residents

Attracts residents requiring a caretaker

Restaurants

Attracts students, shoppers, supporting business,
residents

Theater

Attracts families and business

Malls & Strip Malls

The area is already a hub for retail

Parks

Phoenix Park

Kessler Field

PROGRAM



- Residential
- Mixed Use
- Retail
- Civic
- Park
- Industrial

EXISTING BUILDINGS



Eau Claire is in the process of removing buildings (highlighted) that are currently in the West Bank redevelopment area.

The immediate surrounding area consists largely of single-family residence; however, Eau Claire has expressed a desire to increase density. This should not be at the price of privacy, vegetation and greenspace.

The presence of nearby educational facilities, daycare, and hospitals will attract families to the building complex. The existing retail and mall already make the site a shopping hub.



CIRCULATION

The majority of the vehicular circulation crosses the bridge on Madison St on the southern border of the site. Traffic is also heavier along Oxford Ave and Platt St.

To the north of the site is an unused rail road bridge which I propose become a bicycle bridge as Eau Claire has and is in the process of expanding a system of bicycle paths. Bike parking will be provided on the site for retail, offices, and housing, as well as a public bathroom with showers for bicycle commuters.

EXISTING VEGETATION



The eastern edge of the site slopes to the Chippewa River. This slope is part of a continuous greenbelt that borders the Chippewa River on both sides. In the summer, people float down the Chippewa River from Phoenix Park located in the North Barstow District. There is also a farmer's market in Phoenix Park.

Many of the neighborhoods surrounding the site have large amounts of vegetation; however, this ceases to be typical just south of the site where large un-vegetated parking areas mar the ground.

The site itself is vegetated in large part along the water to the east and the western edge of the site. The trees and brush have grown in such a way that views are difficult to obtain both to and from the site.

As much vegetation as possible should remain; however, careful removal may create view corridors or be replaced with vegetation that residents and visitors to the site may interact with, to smell, taste, hear, and touch as well as to see.



Because of the proximity of the Chippewa River, drainage will have to be carefully considered to avoid pollution.

Swales could aid in cleaning the water before allowing it to be absorbed into the ground or to flow into the river.

Swales and rain gardens should be designed to optimize existing and designed topography. They provide potential opportunities to connect with the water.



The land has a gradual gradient eastward with a final steep gradient sloping down to the water. This area of the site will require careful consideration, particularly as this area is highly vegetated.



Left:
Contours represent 5' intervals

Right:
Contours represent 1' intervals



City of Eau Claire

Greenhouses (accessory) are allowed in residential districts. Commercial Greenhouses are allowed in some commercial districts, and in both industrial districts.

Photovoltaics (solar panels) are allowed per electrical permit.

Wind Energy Conversion Systems are allowed via a condition use permit in all residential, commercial and industrial districts.

Public Districts allow **parks, recreational facilities and other public uses** like schools, government buildings, and power generation plants.

Planned Developments allow **zoning flexibility** to help create master planned neighborhoods which can have a variety of land uses at different levels of densities, reduce infrastructure costs and energy use through the clustering of dwellings/other uses, and preservation of open space/natural areas.

Traditional Neighborhood District allows for narrow streets, multi-modal transportation, compact form, **mixed-use, human scaled, civic/open space**, and traditional design of new or redeveloped projects.

Parking Reductions for planned mixed-use projects that share the parking supply; if bicycle parking is offered; for projects located within 500 feet of a bus route; projects located in downtown; or those that provide a parking study.

Minimum Off-Street Parking Requirements. In order to prevent excessive lot coverage with pavement or similar hard surfaces and to reduce the heat and surface water run-off from excessive parking areas, the off-street parking area for non-residential uses shall not exceed the minimum number of spaces required by more than 25%, except as approved by the Commission, based on a parking analysis that shows the need for the extra parking.

Conditional Uses allow dwellings in most commercial districts, conversion of certain dwellings to greater density, and others uses as already noted.

Light Fixtures should be **shielded to reduce dark sky light pollution** (18.10.060)

Site Plans (18.45) shall follow these regulations:

- All areas not otherwise occupied by structures or paved areas shall be landscaped as per the City's Landscape Manual.

- **Interior circulation of the site** shall be designed to provide for the convenient and safe flow of pedestrians and non-pedestrian traffic on the site and onto and from public streets or sidewalks.

- **Sites shall be lighted with fixtures**, which relate to the scale and design of the development and which have an intensity high enough to maintain security and low enough to avoid being a nuisance.

- **Outdoor activity areas, parking lots, storage yards, trash areas and other exterior features or uses** shall be adequately landscaped or screened to minimize any potential nuisance.

- **Recyclable materials storage areas** are required for any use that generates significant amounts of recyclable materials and such areas shall be screened.

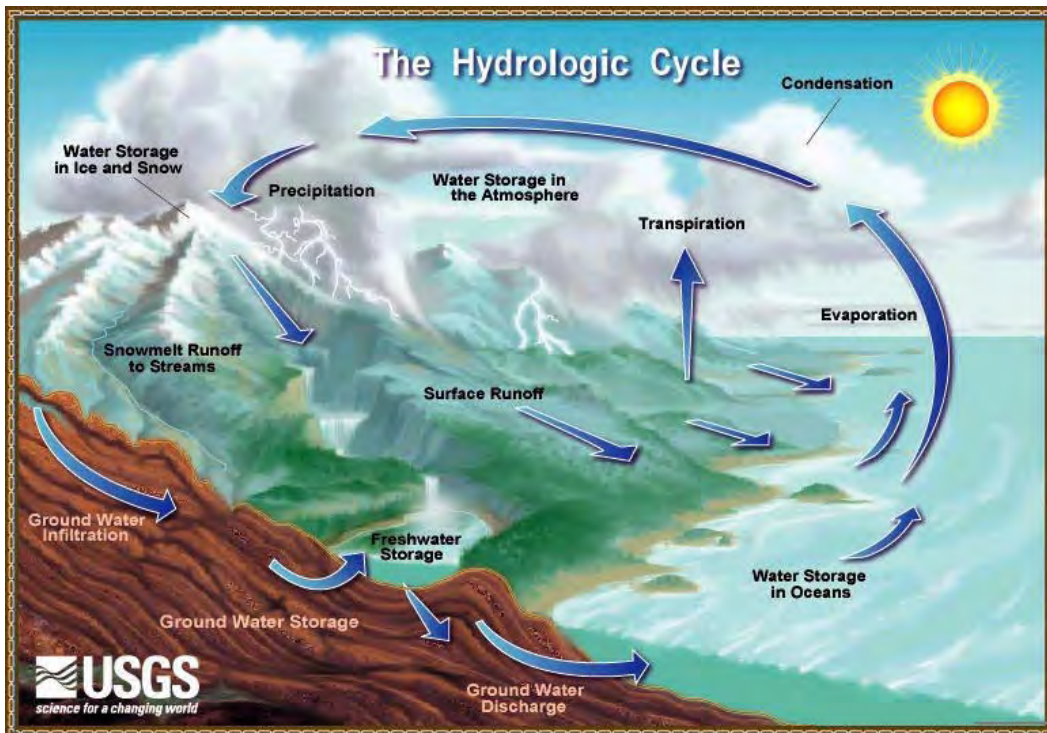

WATER CYCLE

“Water is constantly recycled in a process known as the hydrologic or water cycle. Fresh water is more scarce than you might think. 97% of all the water on the earth is in the oceans, and so only 3% is fresh water. About 2.4% of the water on earth is permanently frozen in glaciers and at the polar ice caps. About 1/2 of 1% of the water on earth is groundwater. Only about 1/100 of 1% of the water on earth is in the rivers and lakes. Water is essential to life on earth, so it is important that we protect our water resources.

“Nature has a way of keeping the amount of water on the earth relatively constant. A large amount of water evaporates from the surfaces of oceans, rivers, and lakes every day. It forms water vapor that rises into the air until it cools, condenses, and forms water droplets. Millions of these droplets come together to form clouds. When clouds get heavy enough, gravity tugs on the droplets, and the clouds release their water as rain or snow. This precipitation falls into streams and rivers, which flow back to the oceans, seas, and lakes, where the water cycle can begin again.” (Utah)

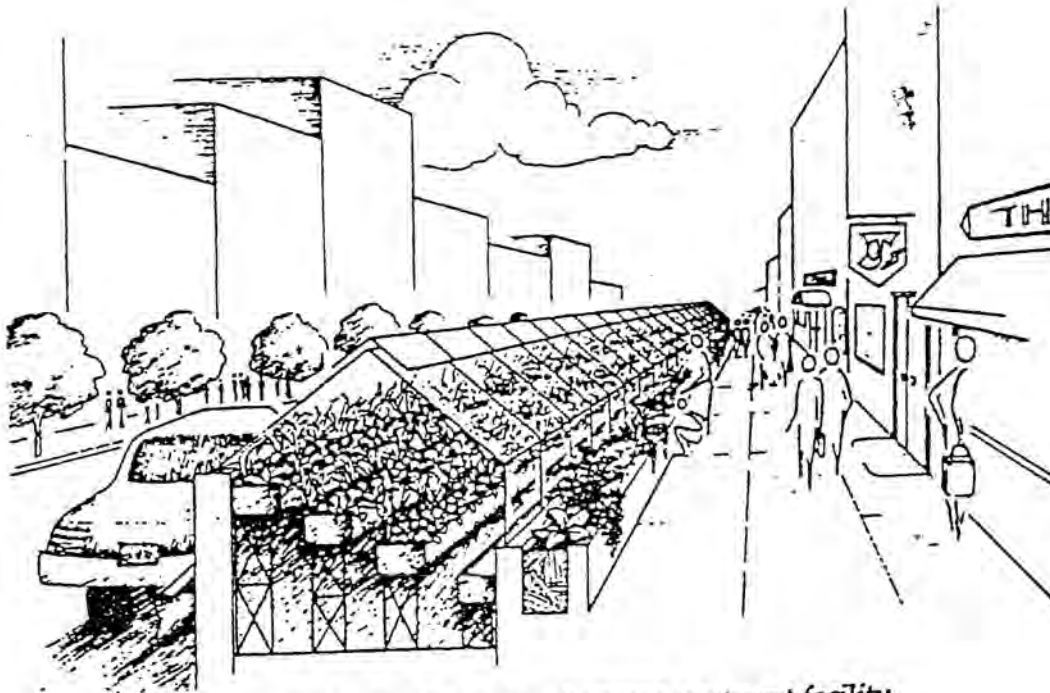

A neighborhood solar-powered sewage treatment facility

WASTE WATER

“Pollution problems resulting from the disposal of human waste are relatively new phenomena. For thousands of years, our body wastes were an intricate part of the planet’s natural recycling system, providing food and fuel for the microorganisms at the bottom of the food chain. But with the huge growth in world population and the concentration of that growth in urban centers, human waste has been disconnected from the cycle. Today our wastes seem to miraculously vanish simply by flushing the toilet. But that’s where the problems begin.” (Guterson)

LIVING MACHINE or SOLAR AQUATIC WASTEWATER TREATMENT

“The biggest blockade to the emergence of living technologies could be the very phenomenon Living Machines are intended to solve, namely, the estrangement of modern cultures from the natural world...These machines can be made beautiful and evocative of a deep harmony that is nature.” (Guterson quoting John Todd)

“It is our hope that by studying human waste recycling in a beautiful, ecologically diverse and dynamic Living Machine, the children will begin to comprehend the meaning of natural systems in their lives. Equally important, it may allow them to engage with the natural world in sustaining the communities of tomorrow.” (Todd)

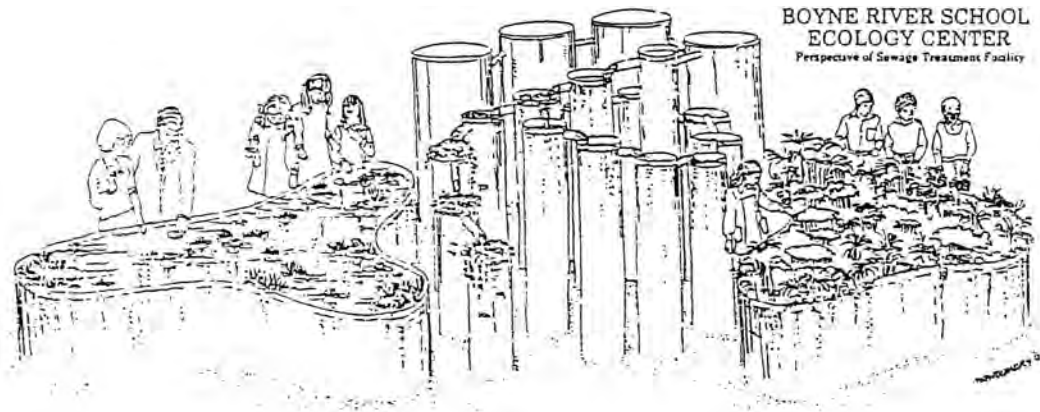

“Sewage waters are transformed by solar energy into clean water as well as fish, flowers and trees...Similar to constructed wetlands but enclosed with bioshelter enclosure. Solar energy is used to transform sewage wastes into various forms of biomass. End products can be fish, flowers, trees as well as clean water.” (Guterson)

At the Boyne River school, “By the time the wastewater passes through a marsh and pond, it is technically well water and legally drinkable. But no one drinks it—the psychological reaction to doing so is too negative. Instead, most of the water is recycled back up to the toilets.” (Guterson)

“A Living Machine’s size, shape, and casing vary according to function. Typically, it involves a series of distinct ecologies each contained within a cylinder. The cylinders communicate through water flowing within connector tubes. Wastes generated by inhabitants of one cylinder flow through the tubes and become food for the inhabitants of another. In this manner, using sunlight as the primary source of energy, compounds are broken down.” (Guterson)

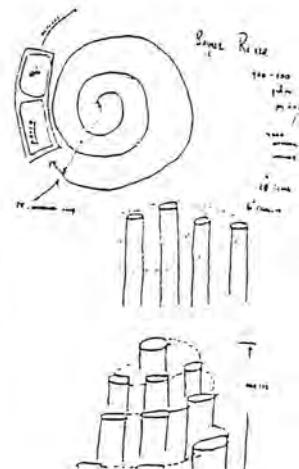
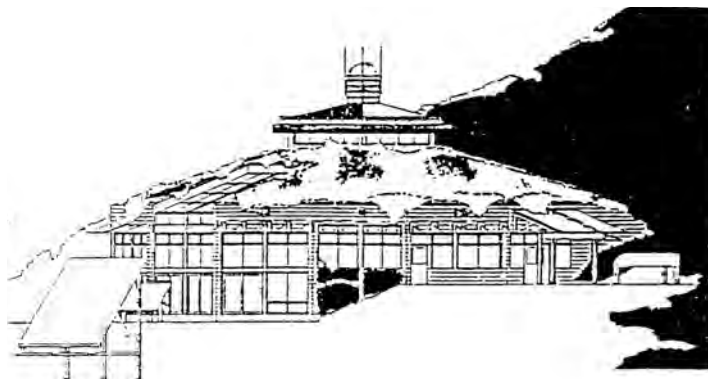

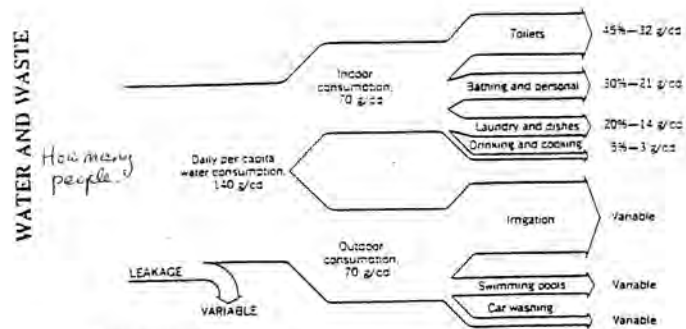

CONVENTIONAL USE

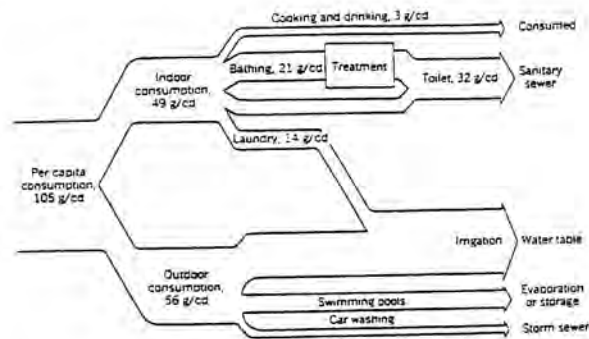

CONSERVING/PARTIAL RECYCLING

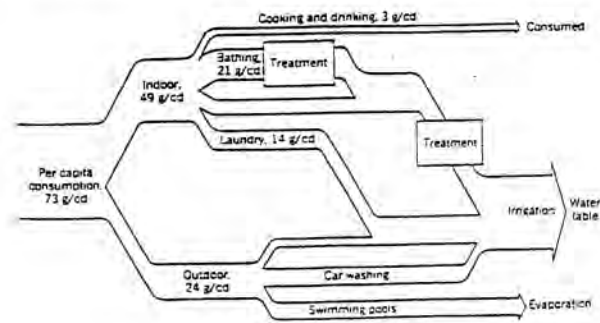

FULL RECYCLING

“To figure the size of a greenhouse for a Solar Aquatic Waste Water Treatment, assume water use to be 100 gallons/day/person in urban areas (EPA design rule) and estimate 4 gal/sf of green house floor area per person, or 25 sf/person. With low flow toilets, showheads and faucets and intelligent use of water, this figure could be reduced to 10 sf/person.” (Guterson)

ENERGY

“The sun is the source of all life on our earth. Every form of energy, except for atomic energy, can be traced back to the sun. Happily, the earth is at the best possible distance from the sun for the sun’s heat to provide this energy for life. Energy from sunlight is used by plants to make food from air, water, and the minerals in the soil. This energy is stored by plants who are the primary producers in ecosystems.

“Energy sources such as the fossil fuels of coal, petroleum, and natural gas are really just ancient stockpiles of the sun’s energy stored in plants and the animals that ate those plants that are thousands or millions of years old. These fuels came from plants that used sunlight when they lived long ago. When these plants died, they fell to the ground where their remains piled up over thousands or millions of years. As this pile grew large, the remains at the very bottom became pressed together. Over time, these remains changed. Some became a gas--natural gas. Some became a liquid--petroleum. Some became a solid or a rock--coal. We use these forms of energy to power vehicles, heat homes, and run industries. Fossil fuels are considered nonrenewable sources of energy because they cannot be replaced once they are used up.” (Utah)

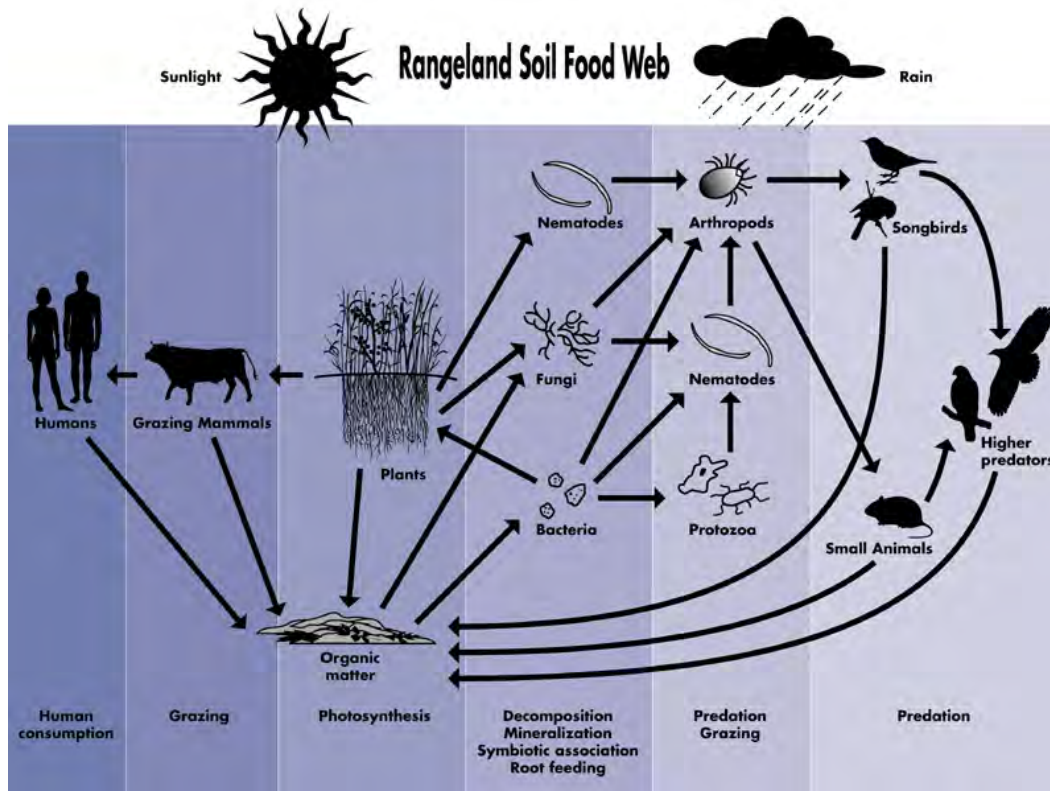

LIFE CYCLE-PLANTS

“There are over 375,000 different species of plants on the earth. They range from tiny, single-celled algae to huge sequoia trees. Life on earth would not be possible without plants because they are the only living things that are capable of converting sunlight into energy. That energy fuels the other processes of life on earth. Because plants make their own food, they are able to live almost everywhere on earth in a wide range of habitats. Many plants have developed special adaptations to help them survive.” (Utah)

LIFE CYCLE-ANIMALS

“The life cycle of an organism refers to the sequence of developmental stages that it passes through on its way to adulthood. Mammals, reptiles, amphibians, birds, fish, insects and other invertebrates--they each have their own unique way of reproducing life. There is an amazing variety of life cycles within the animal world. Surprisingly, only about 3% of all animal species give birth to live young as part of their life cycle. Most animals lay eggs.

“Animals need to eat, to grow, to be safe, and to reproduce. This is all part of the life cycle. Their bodies are adapted in a wonderful range of ways to solve these problems of survival.” (Utah)

SEASONAL CYCLES

“The earth’s atmosphere is about 430 miles thick. Without this layer of gases to protect us, we could not live. We would be scorched by the sun during the day and frozen at night. Most of the atmosphere is a thin mix of gases that is calm and unchanging. But the lowest 7 miles--the layer in which we live and breathe--contains all the weather we experience, and is thick with gases, water, and dust. As the sun warms the land and sea beneath it, the heat keeps this lower 7 miles swirling and churning. It is the constant swirling of this lowest layer, called the troposphere, that gives us everything we call weather--from the gentle showers to raging hurricanes and tornadoes.

“The earth has a clear pattern of wind circulation that results from the effect of the earth’s rotation and the way that the heat of the sun is distributed. It has become easier to view these cycles and patterns because of photos that can now be taken from satellites orbiting the earth. These global patterns cause weather to occur in cycles--the typhoons that are generated from the China Sea and affect southeast Asia--the hurricanes that begin in the Caribbean and affect the southeastern United States and Central America--the tornadoes that travel through the American midwest.” (Utah)

PLANETARY CYCLES

“Our universe has many cycles. Our galaxy, the Milky Way, turns like a wheel, and all the stars within it revolve around its center. Our solar system moves within this galaxy. The sun spins on its axis once every 24 days and 16 hours. The planets turn on their axis and orbit the sun. Moons orbit their planets.

“It took a long time for humans to understand about our planet and its cycles. Humans used to think that the earth was a huge plate that rested on the back of four elephants standing on a giant floating turtle. Or they believed that one of the gods carried the earth on this shoulders.

We now know that the cycles of our planet earth, our moon, and the sun all affect life on earth.” (Utah)

ROCK CYCLES

“Even rocks have a cycle. Rocks are continually circulating in the mantle just below the crust of the earth. They are sometimes thrust up into the crust due to convection currents. Imagine really thick jam slowly cooking in a big pot on a stove. The jam is thick, and when it reaches a high temperature, convection currents circulate through it. Occasionally big bubbles of steam erupt from the jam and splash onto the top of the stove. This is how rocks get thrust up onto the top of the crust from the boiling mantle below. Rocks can also reach the surface when they are spit out by volcanoes.

“Once on the surface of the earth, rocks cool down. Over time, they are broken up or worn down by weather, and the fragments are carried back to the ocean by way of wind, rain, and the flow of rivers and streams. All of these small pieces of rock collect as sediment at the bottom of seas and oceans. The sediment slowly solidifies into rock and is sometimes drawn back down in to the mantle at subduction zones or reaches the surface again as sea levels change or plates collide.” (Utah)

GEOPHYSICAL CYCLES

“The surface of the earth does not hold still. Continents and islands have been coming together, splitting apart, folding, sinking, rising, and rotating for millions of years. They are propelled by forces deep within the earth.

“In recent years, the ability of satellites to send back photographs of the entire surface of the earth has greatly enabled geologists and other scientists to learn more about the geophysical cycles that form our planet.” (Utah)

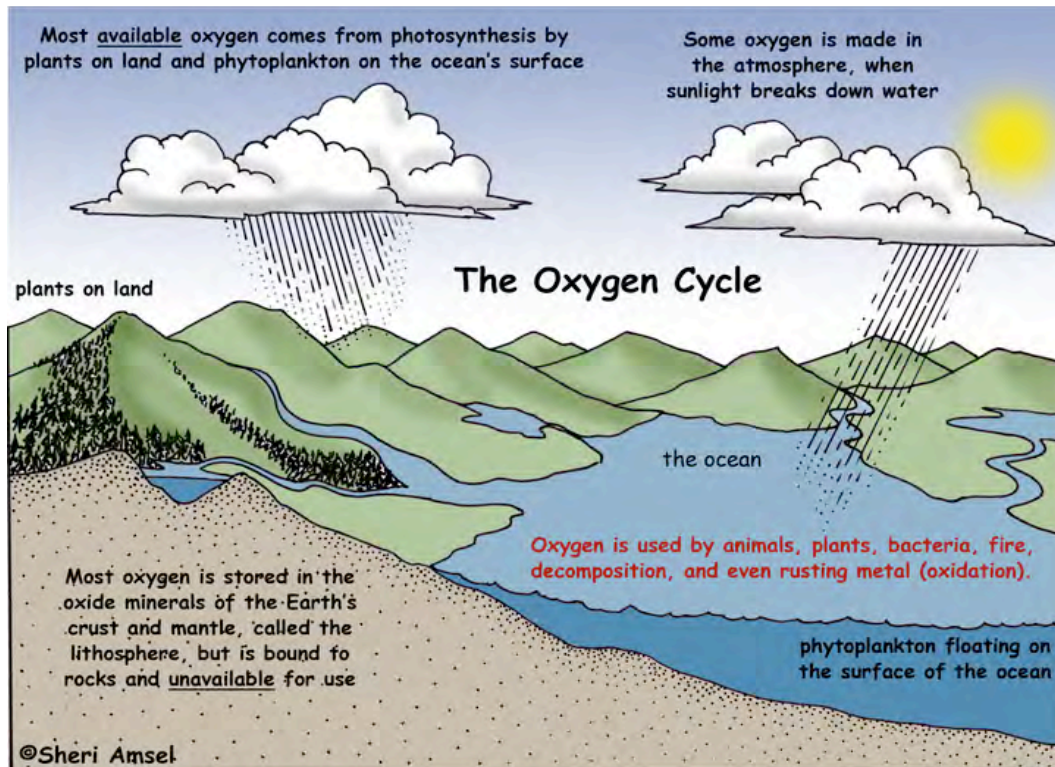

CHEMICAL CYCLES_Oxygen Cycle

“The amount of oxygen in and around the earth is fixed. But this oxygen is fed again and again through the world’s living systems in a never-ending circle called the oxygen cycle. Our needs are just part of this cycle. The cycle involves a continual exchange of gases between the air and animals and plants. In a process called respiration, animals and plants take oxygen from air and give back carbon dioxide. In a process called photosynthesis, plants take carbon dioxide from air and water and give back oxygen. Respiration and photosynthesis are effectively opposite processes. Respiration is an oxidation reaction, which takes oxygen from the air or from water. Photosynthesis is a reduction reaction. It adds oxygen gas to the air. Enormous quantities of oxygen are taken in by plants and animals every day, and huge quantities of oxygen are returned to the air by plants. These amount exactly balance so that overall the amount of oxygen in the air stays the same.”
(Utah)

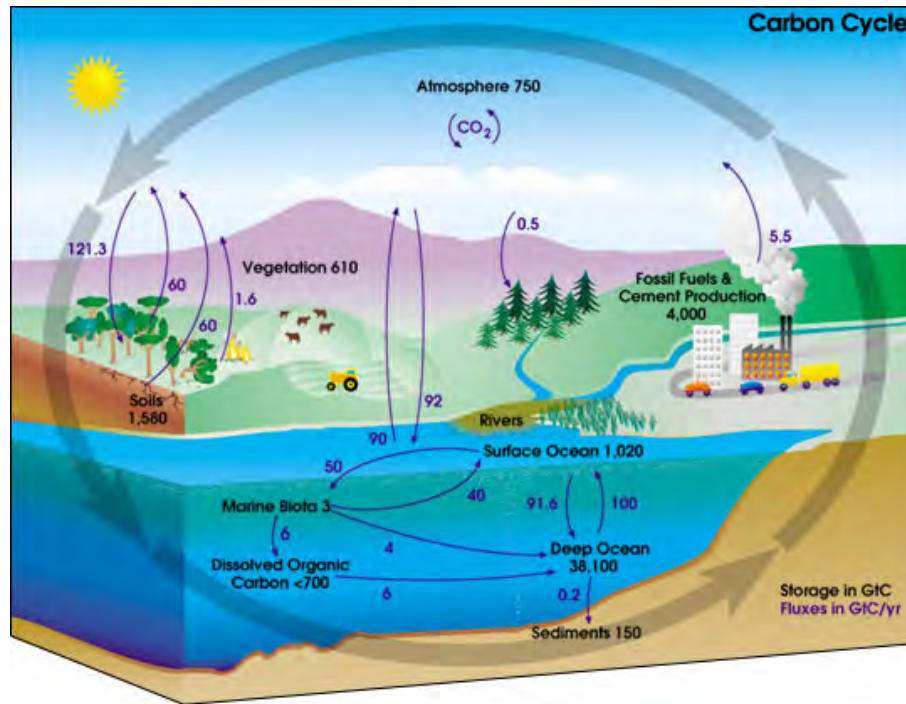

CHEMICAL CYCLES_Carbon Cycle

“Carbon is essential for the chemical processes that support life. It plays such an important role in life that sometimes we say that life is “carbon-based”. But there is only a limited amount of carbon on the earth. So carbon is constantly cycling around the earth, turning up in a lot of different forms and places. The reactions that move carbon around make up a giant web called the carbon cycle.

Plants get carbon by taking carbon dioxide from the air. They use the carbon dioxide and the energy from sunlight to make food. Animals get their carbon by eating those plants or by eating animals that have eaten those plants. When organisms breathe, they take oxygen from the air. During respiration, the oxygen reacts with food to provide energy. Respiration produces carbon dioxide which is released to the air.

“Volcanic eruptions are a source of carbon. When a volcano erupts, it releases huge amounts of carbon dioxide. But remember--the earth needs it elements to stay in balance. So the effect of volcanoes is balanced by weathering which is a chemical reaction between rainwater and rocks that absorbs carbon dioxide from the air to create rock carbonate minerals. Left to themselves, these natural processes are in perfect balance. But human activities can disturb the cycle and increase the amount of carbon dioxide in the atmosphere. This could cause problems in the future because carbon dioxide is vital for controlling the world’s climate.” (Utah)

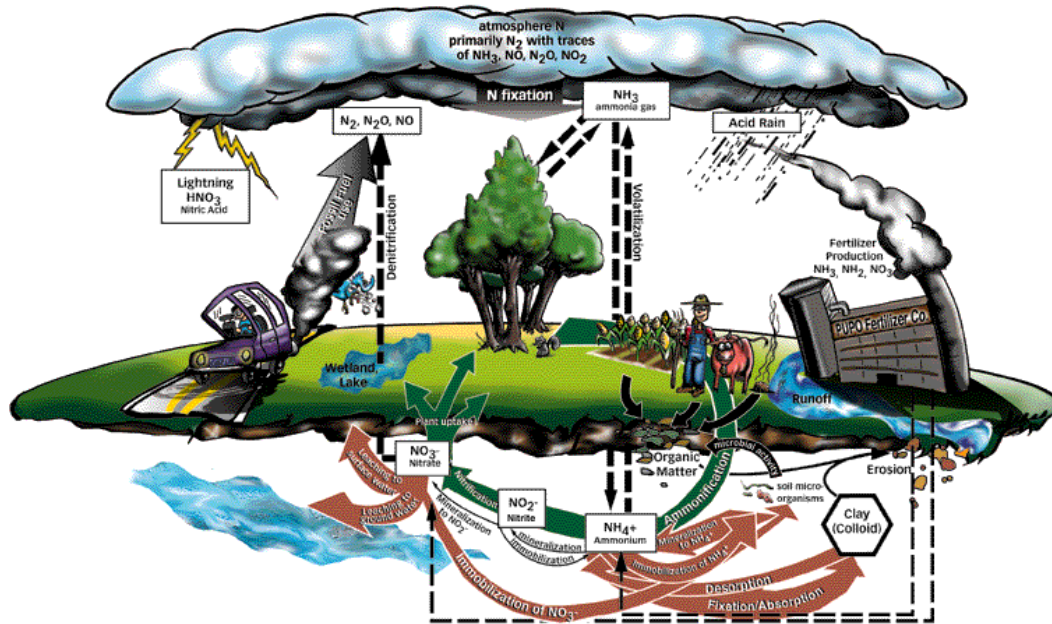

CHEMICAL CYCLES_Nitrogen Cycle

“Nitrogen atoms are constantly moving in a giant circle from the air, through the soil, into the bodies of plants and animals, and eventually back to the air. This whole process is called the nitrogen cycle. All living things need nitrogen to develop and grow. Even though the earth’s atmosphere is made up of 78% nitrogen, plants and animals cannot use it in this form because the nitrogen atoms are too firmly bound together in molecules. So plants must draw their nitrogen from nitrogen compounds dissolved in the soil, and animals get their nitrogen by eating plants or by eating other animals that eat plants.

“The nitrogen gets into the soil in a couple of different ways. A small quantity of the nitrogen found the soil by way of lightning. Lightning changes atmospheric nitrogen into nitrogen dioxide which is soluble in water. The nitrogen oxides dissolve in rainwater to form nitric acid which is absorbed by soil. The rest of the nitrogen in soil comes from bacteria. Bacteria are the only living things capable of getting nitrogen directly from the air. This is called “fixing”. The process is started by certain kinds of bacteria in the soil that can extract nitrogen from the air. Then other bacteria convert the nitrogen into nitrogen compounds called nitrates, This process is called nitrification. Plants absorb the nitrates and turn them into more complex nitrogen compounds. Bacteria also help return nitrogen to the air. Bacteria in the soil decompose animal waste and the remains of dead animals and plants and produce ammonia. Nitrifying bacteria turn the ammonia into nitrates.

Other bacteria, called denitrifying bacteria, convert some of the nitrates back into nitrogen gas, which is released into the air. All these different steps form a massive cycle. The effect is that, over time, bacteria in the soil return almost the same amount of nitrogen to the air as other bacteria take from the air. This keeps the nitrogen content of the earth and its atmosphere in a perfect balance.

“Unfortunately, humans are interfering with the natural balance when they over-use artificially produced nitrates as agricultural fertilizers. Before these nitrates can be converted into atmospheric nitrogen, they are often carried off from the soil by rain or irrigation. These dissolved nitrates are carried to streams and rivers and even seep down to groundwater. In some parts of the world, water for humans and animals contains such high concentrations of nitrates that it is unsafe for consumption. These excessive amount of nitrates, when they reach rivers and lakes, cause too much algae to grow. This over-abundance of algae uses up too much of the oxygen in the water. When oxygen levels fall, other forms of life in the water die off.” (Utah)



An important consideration in selecting plants in regard to their visual characteristics is the season in which they bloom as well as the visual appearance in the winter.

Further, plants may be selected for scent as well as their visual characteristics.

Common Name	Latin Name	Height	Color	Bloom Time	Mois- ture	Spac- ing	Sun
WILDFLOW- ERS							
Canada Anem- one	Anemone canadensis	1' - 2'	white	MAY - JUL	M,Mo	1'	F,P
Wild Ginger	Asarum canadense	1'	red	MAY - JUN	D,M	1'	P,S
Big Leaf Aster	Aster mac- rophyllus	1' - 2'	white	AUG - SEP	D,M	1'	P,S
Stiff Coreopsis	Coreopsis palmata	2' - 3'	yellow	JUN - AUG	D,M	1'	F
Mistflower	Eupatorium coelestinum	1' - 3'	blue/ violet	JUL - OCT	M,Mo	1'	F,P
Prairie Smoke	Geum triflo- rum	6"	pink	MAY - JUN	D,M	6"	F
American Alum Root	Heuchera americana, var. Interior	1' - 3'	red/ green	JUN - JUL	D,M	1'	F,P
Maple Leaved Alum Root	Heuchera villosa, var. Atropur- purea	1' - 2'	white	AUG - OCT	M,Mo	2'	P,S
Obedient Plant	Physotegia virginiana	1' - 2'	pink	AUG - SEP	M,Mo	1'	F
Mayapple	Podophyl- lum pelta- tum	1' - 2'	white	MAY - JUN	D,M	1' - 2'	

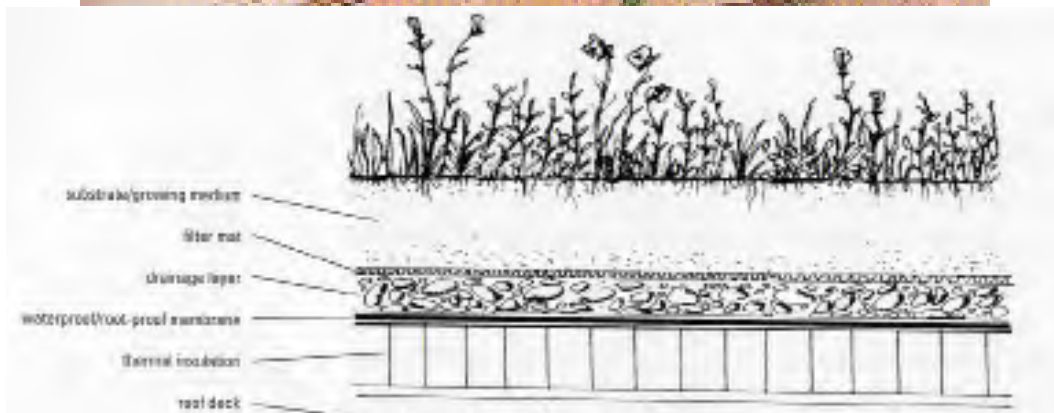

Dunnett, Nigel & Noël Kingsbury. *Planting Green Roofs and Living Walls*. Portland, Or.: Timber Press, 2004.

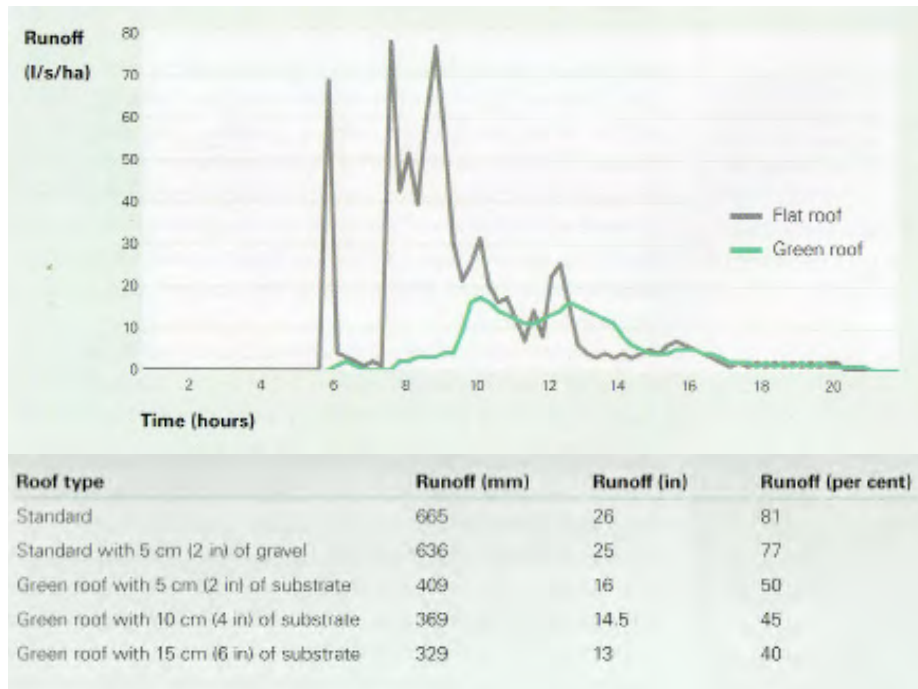

RUNOFF & FLOODING

“Because roofs represent approximately 40-50% of the impermeable surfaces in urban areas, green roofs have an important role in such integrated or sustainable urban drainage systems, low impact design or best management practices (Dunnett and Clayden 2007).

Other components of these systems may be

the use of bioswales (open vegetated drainage channels) as an alternative to buried drainage pipes, allowing water to soak away as well as evaporate back to the air;

rain gardens and stormwater planters that intercept runoff at ground level; stormwater management ponds and drainage basins;

the use of sumps to direct water from floor drainage systems into the water table; and porous road and pavement surfaces, which again promote infiltration rather than runoff (Liptan and Murase 2002).” [Dunnett 55-56]

POLLUTION

“Stormwater running off urban surfaces is also likely to be contaminated with particulates, oil and other synthetic hydrocarbons, heavy metals, road salt, pesticides, and animal waste.

High levels of runoff also create erosion problems...To combat these problems an alternative view of dealing with rainfall and drainage is emerging that aims to dramatically reduce the amount of water leaving a site, either through capturing it and reusing the water for irrigation or domestic use, or encouraging it to infiltrate into the soil or evaporate back into the area.

There are many advantages to this: reducing pressure on urban drainage systems, enabling ground water to be replenished, providing areas of habitat and amenity wetlands, reducing flood risk and, importantly, reducing the cost of drainage schemes...” [Dunnett 55]

“the pH of green roof runoff was consistently higher than that of ungreened roofs. This is a beneficial outcome in terms of combating the effects of acid rain.” [Dunnett 61]

“Vegetation in urban areas can filter out fine airborne particles as the air passes over the plants, settling on to leaf and stem surfaces.” [Dunnett 62]

HEATING & COOLING

“Evapotranspiration is the combined effect of transpiration...and the evaporation of water from the soil and vegetation surfaces...Both processes are powered by solar energy.

As a result this energy is retained within the water vapor and is prevented from being converted into heat at the surface (Bass 2001).

In this regard, the climatic quality of a town is directly related to the proportion of open and vegetated spaces in the total area (Meiss 1979)

...Combining shallow pools or water-collecting basins with vegetated areas on roofs will therefore maximize their benefits.” [Dunnett 65-66]

“Green roofs and facade greening have the ability not just to reduce the costs of heating and cooling buildings, but to reduce construction costs too, as they will reduce the amount of insulation needed or the size of air-conditioning equipment needed.” [Dunnett 76]

SOUND

“Green roofs can absorb sound, however, with both substrate and plants making a contribution, the former tending to block lower sound frequencies and the latter higher ones.” [Dunnett 67]

FIRE

“Regulations in Germany prohibit the use of flammable materials as part of green roof components, and a border of 0.5-1.0m (1.65-3.3 ft) of stones or gravel must be maintained around parapet borders, rooftop windows, chimneys, etc...there is no known example of a fire on a green roof in Germany, despite there being 200.000 m² (2 million ft²) of extensive green roofs... having a seamless green roof in Germany actually entitles you to a 10-20% discount on fire insurance!” [Dunnett 99]

MENTAL HEALTH

“The therapeutic effects of having green plants and nature around one are known to be considerable and include stress reduction, lowering of blood pressure, relief of muscle tension, and increase in positive feelings (Ulrich and Simons 1986).” [Dunnett 86]

HABITAT

“There are also habitats that for a variety of reasons are often at risk, whether in urban or rural areas.

Therefore the construction of similar habitats featuring species that may be rare or endangered in the world may be valuable in their conservation.” [Dunnett 43]

“Green roofs may be thought of as some of the elements in creating functioning habitat and green space networks in cities.

Vegetated roofs can function as stepping stones, creating links between larger habitat patches: parks, gardens, derelict sites, and railway embankments, for example.” [Dunnett 44]

In instances like these, native and endangered plants should be researched for planting as well as plants which endangered animals rely upon for sustenance.

STRUCTURE

Prior to designing the roof and it's supporting structure, it is important to know what load the roof will have to support.

This requires **knowledge of plant root depth** requirements such that the volume of substrate may be determined for calculations involving dead loads.

Specific **irrigation techniques** should also be determined at an early stage of design.

Substrate materials	Weight of a 1-cm layer (kg per square metre)	Weight of a 1-in layer (lb per square foot)
Gravel	16–19	8.4–9.9
Pebbles	19	9.9
Pumice	6.5	3.3
Brick (solid with mortar)	18	9.4
Sand	18–22	9.4–11.4
Sand and gravel mixed	18	9.4
Topsoil	17–20	8.9–10.4
Water	10	5.3
Lava	8	4.1
Perlite	5	2.54
Vermiculite	1	0.51
Light expanded clay granules (LECA)	3–4	1.5–2.0

Material	Weight (kg per cubic metre)	Weight (lb per cubic foot)
Stone (granite, sandstone, limestone)	2300–3000	144–187
Concrete (precast)	2100	131
Concrete (reinforced)	2400	150
Concrete (lightweight)	1300–1600	81–100
Hardwood timber	730	46
Softwood timber	570	35
Cast iron	7300	456
Steel	8000	499

“Facade greening is a living--and therefore self-regenerating--cladding system for buildings. Climbers, or in some cases trained shrubs, are used to cover the surface of a building.” [Dunnett 191]

HEATING & COOLING

“Climbers can dramatically reduce the maximum temperature in a building by shading walls from the sun, the daily temperature fluctuation being reduced by as much as 50%, a fact of great importance in warm summer climate zones.

Buildings are most effectively insulated against high summer temperatures by shading rather than by building insulation into the structure, for the simple reason that shading stops the heat entering in the first place--climbers are one of the most effective ways of achieving this. It has been calculated that a 5.5°C (10°F) reduction in the temperature immediately outside of a building can reduce the amount of energy needed for air conditioning by 50-70%.

The use of evergreen climbers on walls that do not receive sunlight, on the other hand, helps reduce heat loss in winter...Evergreen climbers provide winter insulation, not only by maintaining a pillow of air between the plant and the wall but by reducing wind chill on the wall surface.

Reducing wind chill by 75% reduces heating demand by 25%.

The effectiveness of winter insulation is related to the thickness of growth, which is generally related to the age of the plant...German research results show *Hedera helix* with a thickness of 20-40 cm (8-16 in) is the most effective insulator.

Fundamentally important, however, is plants' role in raising humidity levels to the 45-65% necessary for comfort and respiratory health at comfortable working temperatures of 20-22°C (68-72°F).

POLLUTION

Climbers and urban trees are highly effective at trapping dust and concentrating certain dust-derived pollutants in their tissues, particularly in those tissues that are then discarded.

...heavy metals are thus taken out of the atmosphere and rain and concentrated in a form that then falls to the ground...The removal of dead leaves and branches and their disposal in sites where the concentrated heavy metals can do minimal environmental damage is thus a key factor in reducing the dangers presented by these elements.

MENTAL HEALTH

Plants are good for the psyche as well, and it has been found that **absenteeism is reduced in green offices**.

MAINTENANCE

Climbers on buildings can help protect the surface of the building from damage from very **heavy rainfall and hail**, and may play some role in intercepting and temporarily **holding water during rainstorms**, in the way that green roofs do. They also help to shield the surface from **ultraviolet light**.

HABITAT

Climbers can also be a valuable **hibernation site** for insects, such as lacewings (Chrysopidae species), butterflies, and moths...Evergreens such as *Hedera* species might also play a significant role in providing **sheltered winter roosting** for small birds, many of which can be very vulnerable to winter cold.

Roosting and nesting space for birds and hibernation opportunities for insects...
Nectar sources for insects...Fruit for birds and insects.”

[Dunnett 195-198,229]

CHARACTERISTICS

“Climbers are capable of reaching tall forest trees, so a maximum height of 25-30 m (82-98 ft) can be regarded as practicable.”

[Dunnett 200]

“Many **climbers can be grown as trailers** from planters at high level or from soil at the top of retaining walls...The maximum length that climbers will hang for (at least in temperate zones) is around 5 m (17 ft).”

[Dunnett 208]

“The maximum height that can be realistically greened is 24 m (78 ft), or around eight storeys...Planting on balconies can extend the height at which they are used, although only large containers that are well supplied with nutrients or hydroponic systems can support extensive growth.”

[Dunnett 211]

Self-clinging Climbers

“**Do not require supports**; however, “In their early stages, self-clinging climbers may be encouraged to root onto the substrate by means of a small-mesh trellis or wire netting-type material that presses them against the substrate. Alternatively lightweight vertical training wires about 5 cm (2 in) from the wall can be used.”

Must be **planted at the darkest portion** of the area which they will eventually cover

[Dunnett 203-205]

Twining Climbers

“Because they have a very strong natural tendency to go **vertically**, it is difficult to train them along long horizontal stretches of support--or indeed any support at an angle less than 45 degrees.

For large and heavy climbers, however, supports need to be of a material whose surface roughness will eliminate the possibility of the plant's weight causing it to slip; **steel cable and fiberglass** both offer enough surface friction. The cable or other support needs to be **round in cross-section** with a diameter of 4-30mm (.2-1.2 in).”

[Dunnett 205-206]

AN ARCHITECTURE OF CONNECTION _____ Jessie Renee Davey-Mallo

Technical Research _____ 04_26
Tendrils & Leaf-twining Climbers

“Trellis-type supports...offer the variety of handholds needed by these climbers and the opportunity for weight to be put onto horizontal supports. Vertical and horizontal members need to intersect at 10- to 20-cm (4- to 8-in) intervals for less vigorous climbers such as *Clematis* hybrids, but 25- to 50-cm (10- to 20-in) intervals are often enough for large-growing species such as *Wisteria* and *Vitis*.”

[Dunnett 206-207]

Ramblers & Scramblers

“Ramblers are inherently somewhat ill-disciplined, and do not lend themselves to making their own way politely up supports, but **need constant monitoring and tying in to supports**.

Trellis with sharp angles, for example, made up of rhomboid shapes made from material with a thin cross-section, is particularly effective for climbers with thorns...dimensions of mesh of 25-50 cm (10-12 in) are recommended.

Ramblers can be particularly effective and most easily handled if trained in a largely **horizontal** rather than an entirely vertical direction.”

[Dunnett 207-208]

Wall Shrubs & Fruit Trees

“Wall shrubs are woody species that are grown against walls and then trained and sometimes clipped to ensure they stay close to the wall.

“However, large wall shrubs can fulfil many of the same functional and aesthetic roles as climbers, although there are **few suitable for growing higher than two storeys**. Less of a support system will be needed and in some cases none at all. Nevertheless design and practical considerations often require a very shallow profile for the shrubs.”

[Dunnett 209-210]

SUPPORT

“Broadly speaking there are three means of supporting those species that need it: **trellis** or a framework made up of vertical and horizontal elements, **horizontal supports**, or **vertical supports**.”

[Dunnett 202]

Some materials which may be used as support are wood and metal trellis, cable and wire, plastic and glass fibre, and rope.

“Metal supporting materials can become extremely hot in the sun, leading to **shoot damage and stunted growth**. Dark and large-diameter supports will absorb more heat, so the use of narrow profile or pale or reflective material is recommended where exposure to sun is an issue. Heat damage is exacerbated by close proximity to the wall.”

[Dunnett 213]

“The **distance from the wall** that the support needs to be varies depending upon the thickness of the plant stems...The following are guidelines: 10 cm (4 in) for those with thin stems...15 cm (6 in) for those with thicker stems...20 cm (8 in) for large woody climbers.”

[Dunnett 216]

“Plant **weight** can vary enormously, between 1 and 50 kg/m² (2.2 and 110 lb/ft²) of plant area. To this must be added the weight of **rain and snow** loading: for deciduous plants this is plant weight x2 and for evergreens plant weight x3..”

For **wind** loading, “approximately 0.5 kN/m² for height up to 8 m (26.4 ft) above ground, 0.8 kN/m² between 8 and 20 m (26.4 and 66 ft) above ground, and 1.1 kN/m² above this height.”

[Dunnett 217]

LIVING WALLS

With living walls, “plants are actually growing vertically in a structure attached to a wall surface, but held away from it and separated from it by a waterproof membrane. But there is another, technically simpler, field--the construction of living walls as engineering applications, where plants are an integral part of a wall, generally a retaining wall, designed to hold back soil and rock, stabilize slopes, or contain streamsides and river banks.

[Dunnett 239]

CONSTRUCTION

Growing plants vertically demands: a growing medium, preferably inert and non-biodegradable (to minimize the need for replacement); a means of delivering water/nutrients in solution; a way of holding the growing medium and plants in position.

“Sedums are commonly used on the upper or most sun-exposed surfaces, with ferns and woodland species on the most shaded and sheltered. Surfaces that receive a moderate amount of sunlight can support ferns, grasses and a variety of forbs.”

[Dunnett 241,243]

DRYSTONE WALLS

“Dry or battered walls are particularly appropriate for planting because the joints between the stones are not mortared.

There is much greater scope for vegetation establishment where the wall is retaining soil behind it and plant roots can reach back into this.

Unmortared vertical retaining walls are only safe up to a certain height (usually 1 m, 3 ft) before there is a danger of collapse. To achieve greater stability, dry-stone retaining walls should be constructed at an angle (approximately 5 cm [2 in] for every 12 cm [4.8 in] in height) for optimal plant growth. This not only gives greater strength to the wall but also enables rainwater to percolate down to the roots of any plants growing in the wall.”

[Dunnett 248]

STACKED CONSTRUCTIONS & MODULAR WALLS

“These systems consist of interlocking, dry-stacked precast concrete blocks of varying dimensions with holes inside them that can be filled with gravel and compacted soil. The modules often feature small precast holes through which steel rods can be inserted for added reinforcement.

Because each module can be filled with soil they can be planted, often with hardy shrubs and vines, or seeded with grass mixes.”

[Dunnett 249-251]

LIVING FENCES

“A screen or structure that is not rooted to the ground can be moved around. There may be less maintenance involved than with a hedge--the living fence will stay the same size and it can also give instant impact. There is also the possibility of changing the planting in an artificial structure.

Living fences consist of a supporting framework that keeps the whole structure upright, vegetation layers, and internal growing medium. They are in effect a sandwich of substrate between vegetation layers.

Timber frameworks can hold wire grid sections which contain the substrate on each side. A geotextile mat must be used to stop the substrate spilling through the holes in the grid. Slits cut into the geotextile allow plants to be inserted into the walls. Again, irrigation during very dry periods is essential to maintain vegetation cover.”

[Dunnett 256-258]

BATS

Bats are good neighbors to have around. A single brown bat can eat up to 1,000 mosquitoes in one hour. They are a great natural pest controller.

Bats like tight and warm spaces. They like it to be 80 to 100 degrees in July when they have their young with them. The bat house should be placed in the sun and around 12 to 15 feet off the ground to prevent predators from getting them.

http://www.eparks.org/wildlife_protection/wildlife_facts/bats/bat_house.asp



BATS OF WISCONSIN

Big Brown (*Eptesicus fuscus*)
Red Bat (*Lasiurus borealis*)
Hoary Bat (*Lasiurus cinereus*)
Little Brown (*Myotis lucifugus*)
Northern Myotis (*Myotis septentrionalis*)
Eastern Pipistrelle (*Pipistrellus subflavus*)

Indiana Bat (*Myotis sodalis*) It is one of the most endangered species in North America.

<http://www.milwaukeezoo.org/conservation/bats/wisconsin.php>



Large bat house

http://www.eparks.org/wildlife_protection/wildlife_facts/bats/bat_house.asp

Johnson Bat House

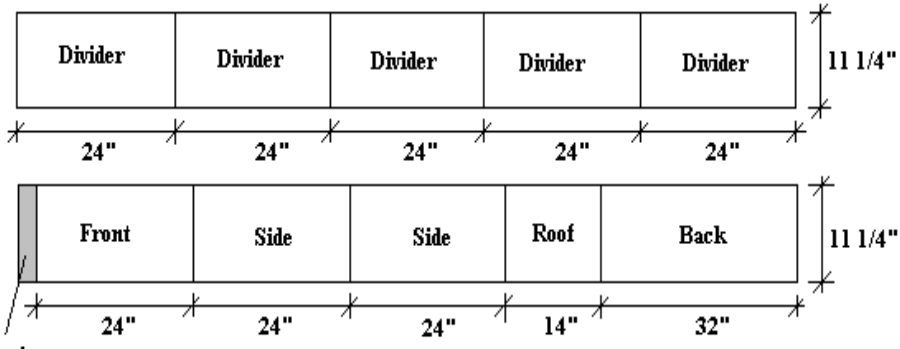
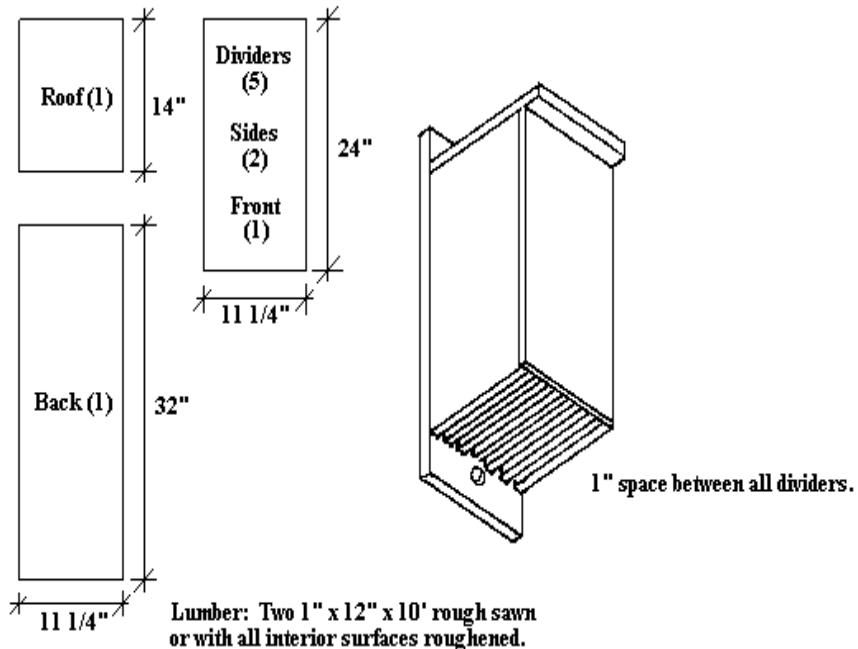

Save!

Note: All external seams and joints should be caulked if not tight fitting. Divider boards are spaced 1 inch apart.

Small bat house

http://www.eparks.org/wildlife_protection/wildlife_facts/bats/bat_house.asp



Single-chamber Bat House (wall mounted)

Materials (makes one house)

1/4 sheet (2' x 4') 1/2" AC, BC or T1-11 (outdoor grade) plywood
 One piece 1" x 2" (3/4" x 1 1/2" finished) x 8' pine (furring strip)
 20 to 30 exterior-grade screws, 1"
 One pint dark, water-based stain, exterior grade
 One pint water-based primer, exterior grade
 One quart flat, water-based paint or stain, exterior grade
 One tube paintable latex caulk
 1" x 4" x 28" board for roof (optional, but highly recommended)
 Black asphalt shingles or galvanized metal (optional)
 6 to 10 roofing nails, 1/2" (if using shingles or metal roofing)

Recommended tools

Table saw or handsaw	Caulking gun
Variable-speed reversing drill	Paintbrushes
Screwdriver bit for drill	Hammer (optional)
Tape measure or yardstick	Tin snips (optional)

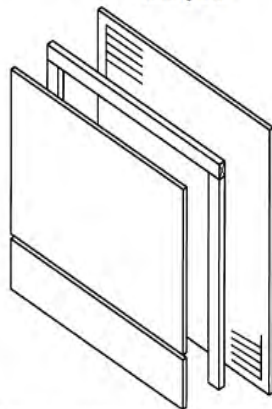
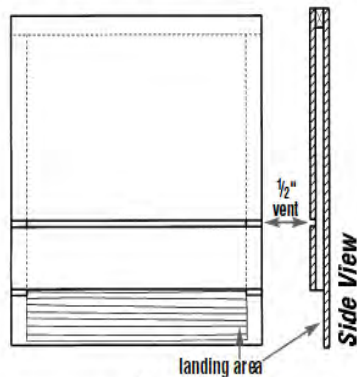

More bat-house plans and additional information can be found in BCI's *Bat House Builder's Handbook*, available at www.batcatalog.com.

Construction

1. Measure and cut plywood into three pieces:
 26 1/2" x 24" 16 1/2" x 24" 5" x 24"
2. Roughen inside of backboard and landing area by cutting horizontal grooves with sharp object or saw. Space grooves 1/8" to 1/4" apart, cutting 1/8" to 1/6" deep.
3. Apply two coats of dark, water-based stain to interior surfaces. Do not use paint, as it will fill grooves.
4. Cut furring strip into one 24" and two 20 1/2" pieces.
5. Attach furring strips to back, caulking first. Start with 24" piece at top. Roost chamber spacing is 1/8".
6. Attach front to furring strips, top piece first (caulk first). Leave 1/2" vent space between top and bottom front pieces.
7. Caulk all outside joints to further seal roost chamber.
8. Attach a 1" x 4" x 28" board to the top as a roof (optional, but highly recommended).
9. Apply three coats of paint or stain to the exterior (use primer for first coat).
10. Cover roof with shingles or galvanized metal (optional).
11. Mount on building (south or east sides usually best).

Optional modifications to the single-chamber bat house

1. Wider bat houses can be built for larger colonies. Be sure to adjust dimensions for back and front pieces and ceiling strip. A 1/8" support spacer may be needed in the center of the roosting chamber for bat houses over 24" wide to prevent warping.
2. To make a taller version for additional temperature diversity, use these modifications: From a 2' x 8' piece of plywood, cut three pieces: 51" x 24", 33" x 24" and 12" x 24". Cut two 8' furring strips into one 24" and two 44" pieces. Follow assembly procedure above.
3. Two bat houses can be placed back-to-back, mounted between two poles, to create a three-chamber nursery house. Before assembly, cut a horizontal 1/8" slot in the back of each house about 9" from the bottom edge of the back piece to permit movement of bats between houses. Two pieces of wood, 1" x 4" x 4 1/4", screwed horizontally to each side, will join the two boxes. Leave a 1/8" space between the two houses, and roughen the wood surfaces or cover the back of each with plastic mesh (see item 5 below). Do not cover the rear exit slots with mesh. One 1" x 4" x 34" vertical piece, attached to each side over the horizontal pieces, blocks light but allows bats and air to enter. A galvanized metal roof, covering both houses, protects the center roosting area from rain. Eaves should be about 3" in southern areas and about 1 1/2" in the north.
4. Ventilation may not be necessary in cold climates. In this case, the front should be a single piece 23" long. Smaller bat houses like this one will be less successful in cool climates. However, those mounted on buildings maintain thermal stability better and are more likely to attract bats.
5. Durable plastic mesh can be substituted to provide footholds for bats. Attach one 20" x 24 1/2" piece to backboard after staining interior, but prior to assembly.

Medium bat house

http://www.eparks.org/wildlife_protection/wildlife_facts/bats/bat_house.asp



U.S. Fish & Wildlife Service

Beneficial Bats

Backyard Habitat for Wildlife

Bat Facts

- Bats, like humans are mammals. Bats are the only mammals that can fly.
- Female bats usually give birth to one young or pup per year.
- Bats are nocturnal—active at night, resting during the day.
- Bats have excellent eyesight, and are never “Blind as a bat!” To find their way around in the dark, they use echolocation or a built in sonar.
- Bats can weigh as little as two grams (less than 1/10 of an ounce) or as much as two pounds.

Bat Food

All southeastern bats found in the United States feed exclusively on insects (the Jamaican fruit-eating bat eats insects and fruit). A bat feasting on moths, mosquitos, beetles and other insects can eat one half of its body weight in one night! Backyard bats will help reduce insect pests that bother you and your garden plants. A typical summer colony of 100 bats feeding 200 days will consume more than 2200 pounds of insects or approximately 600,000,000 bugs!

Bats of the Southeast

- Big Brown Bat
- Silver-haired Bat
- Eastern Red Bat
- Hoary Bat
- Northern Yellow Bat
- Seminole Bat
- Southeastern Bat
- Grey Bat*
- Eastern Small-footed Bat
- Little Brown Bat
- Northern Long-eared Bat
- Indiana Bat*
- Evening Bat
- Eastern Pipistrelle Bat
- Rafinesque’s Big-eared Bat
- Virginia Big-eared Bat
- Ozark Big-eared Bat
- Florida Mastiff Bat
- Pallas’ Mastiff Bat
- Brazilian Free-tailed Bat
- Jamaican Fruit-eating Bat

*endangered species

Attracting Bats

Most eastern bats spend the winter hibernating in caves and move to trees or buildings for the summer. Some however, spend all year in caves and others (tree bats) seldom see a cave, preferring to roost in trees during the warm summers and tree hollows for the cool winters.

As hollow trees are cut down, bat boxes, such as the one shown here, are needed for bats to survive. This is especially true in April to August when females are looking for safe and quiet places to give birth and raise their pups. Both the mothers and newborns are very sensitive to being disturbed.

Install a bat box anytime but late winter and early spring is best. Hang the box at least 10 feet off the ground, in a spot where it can receive six hours of morning sun. About 100 bats can live in this bat box.

Building a Bat House

- Using CDX plywood or cedar, cut all pieces to size.
- To give the bats something to cling to, space shallow saw kerfs or knife gouges about 1" apart on the plywood baffles or staple plastic (not metal) screening instead.
- Screw 3/4" x 1" spacer strips on side panels to make slots for the baffles.
- Attach front panel to sides. Add roof. Glue baffle edges and drop into slots. Attach back panel and caulk.
- Darken with waterbase stain. Tack or staple tar paper to roof of the box to increase heat absorption.

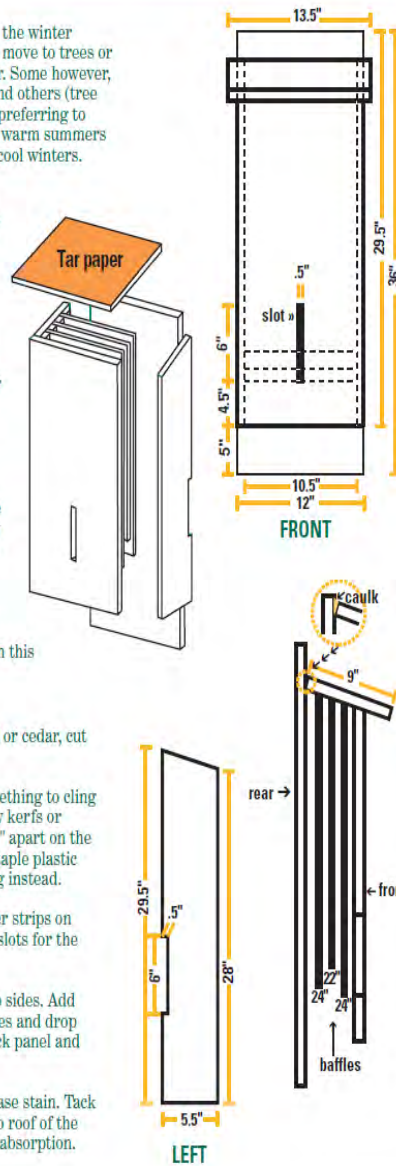

Bat/bird house combination...working on that multi-species density!

http://www.eparks.org/wildlife_protection/wildlife_facts/bats/bat_house.asp

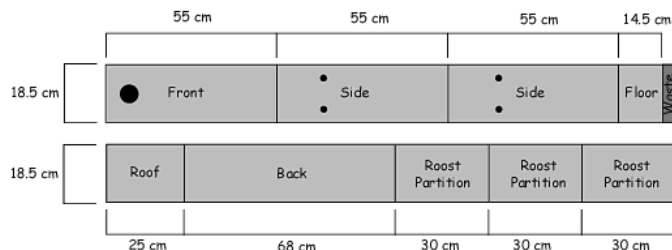
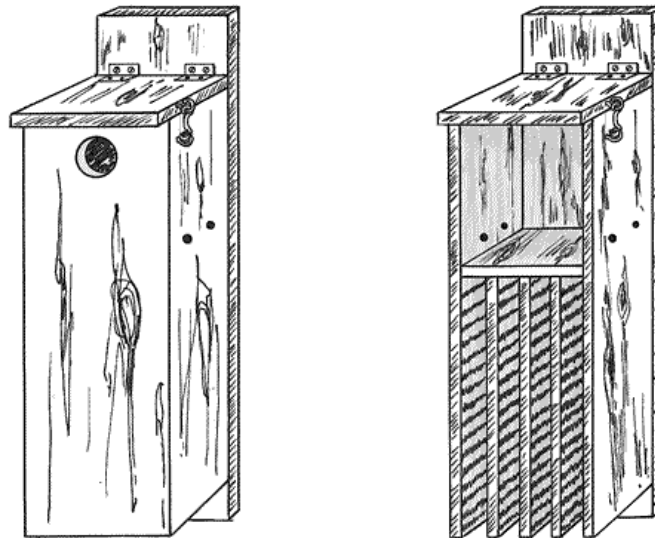

The scarcity of suitable roosting sites threatens bats' survival. Putting up bat houses is a great way to help bat populations. To increase the chance of enticing bats to take up residence in your bat house(s), consider the following:

Temperature is a critical factor in roost selection. In Canada, bat houses should receive at least ten hours of direct sun each day, and more is better.

Mount bat houses on poles or on the side of a building at least 12 feet (4 metres) above the ground (the higher the better). Houses mounted on trees are more difficult for bats to find and more vulnerable to predators.

Bats need to drink water every night, so houses located less than a quarter mile (400 metres) from a water source, such as a stream, river, or lake, have the greatest success in attracting bats. Bats like a clear swoop zone to get in and out of their roosts, so avoid placing the house in an area where there are a lot of obstacles, such as tree branches.

Placing two or more houses in one location allows bats to better respond to changes in temperature by allowing them to move between the houses as needed.

Do not mount houses close to bright lights.

In Canada's cold climate, bat houses should be painted black or dark brown to increase the inside temperature. Use water-based paint or stain, not oil-based. Apply three coats.

Be sure to use untreated wood for your bat house. Pressure treated wood may contain chemicals harmful to bats.

The inside of bat houses must be roughened to allow bats to grip. Create horizontal (not vertical) scratches or grooves. Space cuts roughly $\frac{1}{2}$ inch (13 mm) apart and $\frac{1}{16}$ or $\frac{1}{32}$ inch (1 or 1.5 mm) deep. An alternative is to attach plastic (not metal) screening flat on the wood surface to avoid injury to the bats.

Be sure to caulk all seams, especially around the roof, to prevent drafts and keep temperatures stable.

Use exterior grade or galvanized screws rather than nails.

If after two years your bat house has failed to attract occupants, try moving it to a new location.

two-chamber rocket box

Materials List

One 2-inch (5-cm) inside diameter metal pole ($2\frac{1}{2}$ inch (6.4 cm) outside diameter), 20 feet (6 metres) long

Two 1 x 10-inch x 8 feet rough-cut cedar or pine ($\frac{3}{4}$ inch x $9\frac{1}{4}$ inch x 8 feet finished). Cut each board into two lengths of 36 inches (90 cm). Keep one leftover piece to make the roof cap.

Two 1 x 8-inch x 8 feet rough-cut cedar or pine ($\frac{3}{4}$ inch x $7\frac{1}{2}$ inch x 8 feet finished) cut to $\frac{3}{4}$ inch x $6\frac{1}{4}$ inches x 8 feet. (Keep leftover strips to make spacer blocks.) Cut each board into two lengths of 42 inches (105 cm).

Two 1 x 4-inch x 8 feet rough-cut cedar or pine ($\frac{3}{4}$ inch x $3\frac{1}{2}$ inch x 8 feet finished) cut to $\frac{3}{4}$ x $3\frac{1}{4}$ inches x 8 feet. Cut each board into two lengths of 45 inches (112 cm).

One box of 100 deck screws (Robertson) - size 8 x $1\frac{1}{4}$ -inch

One box of 100 deck screws (Robertson) - size 6 x $1\frac{5}{8}$ -inch

One tube exterior latex caulking (paintable)

Two quarts (2.26 litres) flat latex exterior paint - black or dark brown

One sheet-metal roof (as illustrated) or one square plastic roof vent (more economical and easier to find)

One fence bracket to fit the pole

Four 2-inch (5-cm) screws

Instructions

Rocket boxes were originally designed to fit over a 4 x 4-inch (10 x 10-cm) wooden post (untreated). To increase durability, the following directions replace the post with a wooden pole sleeve attached to a metal pole.

You can try mounting the rocket box on a building, but place it on the south or southeast side to get the most sun. Close off the bottom of the pole sleeve with leftover board to keep wasps or hornets from taking up residence.

The two-chamber rocket box consists of 3 shells (as illustrated). (The extended length of the inner shell and pole sleeve acts as a landing surface for the bats.) Each shell is a perfect square.

The heights given for the box shells should serve as a minimum. The box can be made taller. $\frac{3}{4}$ -inch (20-mm) finished size of lumber is required because $\frac{3}{4}$ inch (20 mm) spacing is critical for the roosting chambers. If another size lumber is used, the dimensions must be adjusted accordingly.

http://www.eparks.org/wildlife_protection/wildlife_facts/bats/bat_house.asp

Pole Sleeve

Assemble the four 45-inch (112-cm) boards into a box using 1-5/8-inch (4-cm) screws and caulk. Roughen the outer surface on each side (see "Putting Up a Bat House").

Cut 40 spacer blocks from the $\frac{3}{4}$ -inch (20-mm) strips of finished lumber scraps, approximately 3 inches (7.5 cm) long. (Helpful hint: when marking off for cutting, indicate the side to be attached to the box to give $\frac{3}{4}$ -inch spacing for the chamber.)

Cut 8 spacer blocks from the $\frac{3}{4}$ -inch (20 mm) strips, approximately 6 inches (15 cm) long. Drill one 1/8-inch (3 mm) hole at both ends of each spacer block to prevent splitting. Smooth any rough edges on the spacers.

On three sides of the pole sleeve, attach two spacer blocks (one on the left, one on the right) at the top and center, using 1 $\frac{1}{4}$ -inch (3.1-cm) coated deck screws (two screws per spacer). Attach the two bottom spacers 8 inches (20 cm) from the bottom of each of the three sides.

Repeat this procedure on the fourth side using four of the 6-inch (15 cm) spacer blocks at the top and 8 inches (20 cm) from the bottom.

Inner Shell

Roughen both sides of each of the four 42-inch (105-cm) boards.

In two of the boards, cut a 1 $\frac{1}{2}$ -inch (3.75-cm) circular hole using a 1 $\frac{1}{2}$ -inch (3.75-cm) hole saw (for bat passage between chambers), centered horizontally, about 10 $\frac{1}{2}$ inches (26 cm) from the bottom end. Sand the hole to remove any splinters. The passage holes will be on opposite sides of the house.

Assemble three of the boards into an open box using 1-5/8-inch (4 cm) deck screws and caulk. Place the pole sleeve into the inner shell (bat passage holes to the bottom) so that the side of the pole sleeve with the longer spacer blocks is to the open side. Align the top of the pole sleeve with the top of the inner shell.

On the fourth 42-inch (105-cm) board, mark the position of the top and bottom spacers. Attach the fourth board to the inner shell using 1-5/8-inch (4-cm) deck screws and caulk. Secure the inner shell to the pole sleeve by screwing two 1-5/8-inch (4 cm) deck screws into the centre part of each of the 6-inch (15-cm) spacer blocks. Ensure the screws do not protrude into the roosting chambers.

Attach spacer blocks to the outside of the inner shell following the same directions as for the pole sleeve.

Outer Shell

Roughen the inside surfaces of the 36-inch (90-cm) boards.

Assemble the outer shell and attach to the inner shell following the above instructions. (Note: do not drill bat passage holes into the outer shell.)

Roof

For the roof cap, measure the outer shell and cut accordingly using the leftover wood from your 9¼-inch (23.5-cm) wide board. (Note: This will not cover exactly, so you must centre the piece, then caulk and screw.) Caulk all edges and attach to the box with 1¼-inch (3.1-cm) deck screws. Carefully drive the screws in the top edges of the outer shell to prevent them from straying into roosting chambers.

Attach a sheet metal roof (as illustrated), pop riveted, caulked, and painted black.

OR

Unclip the roof vent top from the bottom piece. Apply caulking generously to the underside of the vent top and set firmly onto the roof cap. Do not screw on.

Final Steps

Paint the outer surface of the box (see “Putting Up a Bat House”).

Attach the fence bracket to the bottom of the pole sleeve using four 2-inch (5-cm) screws.

Place the pole into the fence bracket and tighten with the bracket screw.

See “Putting Up a Bat House” for ideal placement.

These plans were adapted from a design by John Wilcox generously provided by Bat Conservation International (BCI). Please report successes or failures with your bat house to BCI at (512) 327-9721 or mkiser@batcon.org.

CWF would like to thank Bat Conservation International for their help. For more information on bats or bat houses check out their very informative website at www.batcon.org.

Illustrations by Michel Poirier

bats meet birds

imagine ...bats and birds living together. Often coexisting in snags and artificial structures, these odd housemates get along remarkably well. Most bats and birds work separate shifts - nocturnal and diurnal - and are not at risk of infecting each other since they carry different parasites. The best way to preserve this happy marriage is to save snags. (These standing dead trees are also homes to countless other creatures.) The next best resort is to provide artificial accommodations.

Rather than building separate structures, why not meet the needs of both bats and birds in a single structure with different compartments? The following design will lodge big brown, little brown, pipistrelle, and other colonial bats, plus migratory birds as tree swallows and great-crested flycatchers. With modifications, it will house other cavity-nesting birds, from wood ducks to woodpeckers.

Use 2 cm (3/4”) softwood lumber, such as cedar or pine. Do not use pressure-treated wood. It can be toxic to young bats and birds.

Cut the front, sides, floor, roof, back and partitions.

Bore an entrance hole in the front panel (4 cm in diameter for bluebirds and tree swallows, 5 cm

for great-crested flycatchers) 4 cm from the top.

Drill small drainage holes on the side panels, just above the floor.

Saw shallow, horizontal grooves (2 mm deep and 1 cm apart) on the inner surfaces of the bat section, including the walls and roost partitions, to enable bats to crawl inside.

Assemble the pieces according to the construction plan, using 4 cm (2") coated flat-head screws and bond-fast glue. The opening between the roost partitions should be 2 to 2.5 cm wide.

Paint the outside of the structure dark brown or grey.

In early April, choose a site near a lake, pond, marsh, stream, or river with plenty of insects, ideally inhabited by the species you hope to attract.

Hang the box 3 to 5 m off the ground on a tree-trunk or, preferably, the side of a building that faces east or southeast and catches the morning sun. The spot should be sheltered from the wind and at least 6 m from neighbouring trees. To prevent house sparrows and European starlings from moving in, leave the entrance to the upper compartment covered until bird migrants appear in spring. Have patience. Your structure may remain vacant for a year or two, but its dual purpose doubles the chance that bats and birds will eventually move in.

Clean the box each fall and ensure that it stays in good repair

hot under the collar Much to the surprise of wildlife biologists, sheet-metal collars wrapped around trees not only protect nesting birds from predators but also create ideal roosts for bats. Corrugated metal, loosely fitted, allows bats that normally roost under bark to regulate their temperatures by crawling around a tree to the sunny or shady side. Unlike loose bark, these metal collars can be placed where needed and last for years. They should be at least a metre wide, secured along the seam with aluminum nails, and have enough space underneath (two or three centimetres wide) that bats can enter and move around

http://www.eparks.org/wildlife_protection/wildlife_facts/bats/bat_house.asp

**Nest conditions:**

Platforms of sticks in trees or shrubs

Lower on the food chain...prey:

Fish, crustaceans, insects

Stalk prey in shallow water & open fields

Snowy Egret

The Snowy Egret (*Egretta thula*) is a small white heron. It is the American counterpart to the very similar Old World Little Egret, which has established a foothold in the Bahamas.

Adults are typically 61 cm long and weigh 375 g. They have a slim black bill and long black legs with yellow feet. The area of the upper bill, in front of the eyes, is yellow but turns red during the breeding season, when the adults also gain recurved plumes on the back, making for a “shaggy” effect. The juvenile looks similar to the adult, but the base of the bill is paler, and a green or yellow line runs down the back of the legs.

Their breeding habitat is large inland and coastal wetlands from the lower Great Lakes and southwestern United States to South America. The breeding range in eastern North America extends along the Atlantic and Gulf Coasts from Maine to Texas, and inland along major rivers and lakes. They nest in colonies, often with other waders, usually on platforms of sticks in trees or shrubs. Their flat, shallow nests are made of sticks and lined with fine twigs and rushes. Three to four greenish-blue, oval eggs are incubated by both adults. The young leave the nest in 20 to 25 days and hop about on branches near the nest before finally departing.

In warmer locations, some Snowy Egret are permanent residents; northern populations migrate to Central America and the West Indies. They may wander north after the breeding season, very rarely venturing to western Europe—the first bird sighted in Britain wintered in Scotland from 2001–2002.

The birds eat fish, crustaceans, and insects. They stalk prey in shallow water, often running or shuffling their feet, flushing prey into view, as well “dip-fishing” by flying with their feet just over the water. Snowy Egrets may also stand still and wait to ambush prey, or hunt for insects stirred up by domestic animals in open fields.

At one time, the beautiful plumes of the Snowy Egret were in great demand by market hunters as decorations for women’s hats. This reduced the population of the species to dangerously low levels.

Now it is protected by law, under the Migratory Bird Treaty Act, this bird’s population has rebounded.

References

Database entry includes justification for why this species is of least concern

Stiles and Skutch, A guide to the birds of Costa Rica ISBN 0-8014-9600-4

National Geographic, Field Guide to the Birds of North America ISBN 0-7922-6877-6

External links

Snowy Egret Species Account - Cornell Lab of Ornithology

Snowy Egret *Egretta thula* - USGS Patuxent Bird Identification InfoCenter

Snowy Egret Information and Photos - South Dakota Birds and Birding

Field Guide on Flickr



Nest conditions:

Scrape: “A rudimentary ground nest site, usually with no lining, that a bird forms by creating a shallow depression in the ground.”

Lower on the food chain...prey:

Medium sized birds, small mammals, small reptiles, insects

Peregrine Falcon

The Peregrine Falcon (*Falco peregrinus*), also known simply as the Peregrine , and historically as the “Duck Hawk” in North America, is a cosmopolitan bird of prey in the family Falconidae. It is a large, crow-sized falcon, with a blue-gray back, barred white underparts, and a black head and “moustache”. It has the ability to reach speeds over 322 km/h (200 mph), making it the fastest animal in the world. As with other bird-eating raptors, the female is bigger than the male. Authorities recognize 17–19 subspecies, which vary in appearance and range; there is disagreement over whether the distinctive Barbary Falcon is a subspecies or a distinct species.

The Peregrine’s breeding range includes land regions from the Arctic tundra to the Tropics. It can be found nearly everywhere on Earth, excepting extreme polar regions, very high mountains, and most tropical rainforests; the only major ice-free landmass from which it is entirely absent is New Zealand. This makes it the world’s most widespread bird of prey. Both the English and scientific names of this species mean “wandering falcon”, referring to the migratory habits of many northern populations.

While its diet consists almost exclusively of medium-sized birds, the Peregrine will occasionally hunt small mammals, small reptiles or even insects. It reaches sexual maturity at one year, and mates for life. It nests in a scrape, normally on cliff edges or, in recent times on tall man-made structures. The Peregrine Falcon became an endangered species due to the use of pesticides, especially DDT. Since the ban on DDT from the beginning of the 1970s onwards, the populations recovered, supported by large scale protection of nesting places and releases to the wild.

Description

The Peregrine Falcon has a body length of 34–50 cm (13–20 in) and a wingspan of around 80–120 cm (31–47 in). The male and female have similar markings and plumage, but as in many birds of prey the Peregrine Falcon displays marked reverse sexual dimorphism in size, with the female measuring up to 30 percent larger than the male. Males weigh 440–750 g, and the noticeably larger females weigh 910–1500 g; for variation in weight between subspecies, see under that section below. The back and the long, pointed wings of the adult are usually bluish black to slate gray with indistinct darker barring (see “Subspecies” below); the wingtips are black. The underparts are white to rusty and barred with thin clean bands of



Nest conditions:

“Open cup placed on the ground, hidden among dead leaves.”

Lower on the food chain...prey:
Insects

Worm-eating Warbler

The Worm-eating Warbler (*Helmitheros vermivorus*) is a small New World warbler. It is the only species classified in the genus *Helmitheros* . It is 13 cm long and weighs 13 g. It is relatively plain with olive-brown upperparts and light-coloured underparts, but has black and light brown stripes on its head. It has a slim pointed bill and pink legs. In immature birds, the head stripes are brownish.

This bird breeds in dense deciduous forests in the eastern United States, usually on wooded slopes. The nest is an open cup placed on the ground, hidden among dead leaves. The female lays 4 or 5 eggs. Both parents feed the young; they may try to distract predators near the nest by pretending to be injured.

In winter, these birds migrate to southern Mexico and Central America.

Worm-eating Warblers eat insects, usually searching in dead leaves or bark on trees and shrubs, also picking through dead leaves on the forest floor. Despite their name, they rarely if ever eat earthworms.

The male's song is a short high-pitched trill. This bird's call is a chip or tset . Worm-eating Warblers have disappeared from some parts of their range due to habitat loss. They are vulnerable to nest parasitism by the Brown-headed Cowbird where forests are fragmented.

<http://www.reference.com/browse/worm-eating+warbler>

T



Nest conditions:

“bulky cup made of twigs and grass.”

Lower on the food chain...prey:

Large insects, rodents, small birds-requires barbed wire or thorns for killing prey

Loggerhead Shrike

The Loggerhead Shrike (*Lanius ludovicianus*) is a passerine bird. It is the only member of the shrike family endemic to North America.

The bird has a large hooked bill; the head and back are grey and the underparts white. The wings and tail are black, with white patches on the wings and white on the outer tail feather. The black face mask extends over the bill, unlike that of the similar but slightly larger Northern Shrike.

The bird breeds in semi-open areas in southern Ontario, Quebec and Alberta, south to Mexico. It nests in dense trees and shrubs. The female lays 4 to 8 eggs in a bulky cup made of twigs and grass.

The shrike is a permanent resident in the southern part of the range; northern birds migrate further south.

The bird waits on a perch with open lines of sight and swoops down to capture prey. Its principal food is large insects; it also takes rodents and small birds. Known in many parts as the “Butcher Bird,” it impales its prey on thorns or barbed wire before eating it, because it does not have the talons of the larger birds of prey.

The population of this species has declined in the northeastern parts of its range, possibly due to loss of suitable habitat and pesticide use.

“Loggerhead” refers to the relatively large head as compared to the rest of the body.

Conservation status

The Loggerhead Shrike is critically endangered in Canada (although not in the United States). A captive population was established at the Toronto Zoo and McGill University in 1997. Ten offspring have been produced that will be released as an experiment.

<http://www.reference.com/browse/loggerhead+shrike>



Bewick's Wren

The Bewick's Wren (*Thryomanes bewickii*) is a wren native to North America. At about 14 cm long, it is gray-brown above, white below, with a long white eyebrow. While similar in appearance to the Carolina Wren, it has a long tail that is tipped in white. The song is loud and melodious, much like the song of other wrens. It lives in thickets, brush piles and hedgerows, open woodlands and scrubby areas, often near streams. Its range is from southern British Columbia, Nebraska, southern Ontario, and southwestern Pennsylvania south to Mexico, Arkansas and the northern Gulf States. It usually lays 5–7 eggs that are white with brown spots.

This is currently the only species of its genus, *Thryomanes*. The Socorro Wren, formerly placed here too, is actually a close relative of the House Wren complex, as indicated by biogeography and mtDNA NADH dehydrogenase subunit 2 sequence analysis, whereas *Thryomanes* seems not too distant from the Carolina Wren.

<http://www.reference.com/browse/bewick%27s+wren>

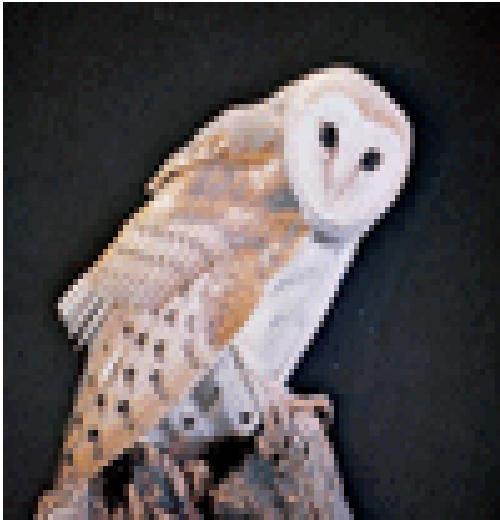

Nest conditions:

“hollow trees, buildings, towers, and old hawk nests”

Lower on the food chain...prey:

Small rodents

barn owl

Common barn owl (*Tyto alba*).

Any of several species of nocturnal birds of prey (genus *Tyto*), sometimes called monkey-faced owls because of their heart-shaped facial disk and absence of ear tufts. Barn owls are about 12–16 in. (30–40 cm) long, white to gray or yellowish to brownish orange. Their dark eyes are smaller than those of other owls. They hunt mainly small rodents, often on cultivated land, and nest in hollow trees, buildings, towers, and old hawk nests. The common barn owl is found worldwide except in Antarctica and Micronesia. Other species occur only in the Old World.

<http://www.reference.com/browse/barn+owl>

“The location of a bird house or food shelter has much to do with its success, for the reason that birds have decided notions as to proper surroundings for a dwelling. Martins prefer to breed near houses, but not within 20 feet of trees or buildings. Bluebirds are inclined to select orchards or pastures having scattered trees. Wrens, thrashers, and catbirds live in thick shrubbery. Robins like trees with sturdy trunks and branches. Titmice, nuthatches, and most of the woodpeckers are woodland species, although flickers and red-headed woodpeckers are more at home among the scattered trees of roadsides and pastures. Song sparrows frequent weedy swales and brush fences. Swallows do not enter woods so that a house would be as attractive to them in one open place as in another. The eastern phoebe, the black phoebe, and the house finch, while not limited to the haunts of man, are noticeably partial to them. Crested flycatchers, screech owls, barn owls, and sparrow hawks are governed more by convenience than by taste; although normally inclined to hold aloof from man, they have in many instances reared their broods in close proximity to dwellings. Barn owls, true to their name, accept suitable quarters in buildings without hesitation.

“House birds differ decidedly in their requirements. For those which usually excavate homes for themselves, the diameter of the entrance and the depth and diameter of the cavity must be in accord with their specific standards. Some birds are satisfied with almost any sort of a lodging. Bluebirds and wrens, for example, are content to build in tomato cans, although chickadees and nuthatches disdain them. Wood is a better building material than metal or earthenware. Entrance holes should be countersunk from the outside to exclude rain. Heads of nails and screws should be set rather deeply and covered with putty. All houses should be easy to open for cleaning. A perch at the entrance is unnecessary and may even be an objection, as it is frequently used by English sparrows while they twitter exasperatingly to more desirable occupants. To provide for proper ventilation a row of small holes is sometimes bared just beneath the eaves, but there should never be a ventilating hole lower than the entrance, and joints should be made tight, as drafts of air are dangerous. In case there is danger that rain may be driven in through the door; a small drainage hole, which will be covered by the nest, may be made in the middle of the floor. The appearance and durability of houses are improved by a coat of paint. A neutral shade of green or gray is suitable for houses mounted in trees, while those on pales, being conspicuously placed, lend themselves harmoniously to the landscape when painted white. The dimensions of nesting boxes shown in Table 1 are taken from the experience of successful builders and from measurements of woodpecker holes. “ (<http://www.freebirdhouseplans.net/>)

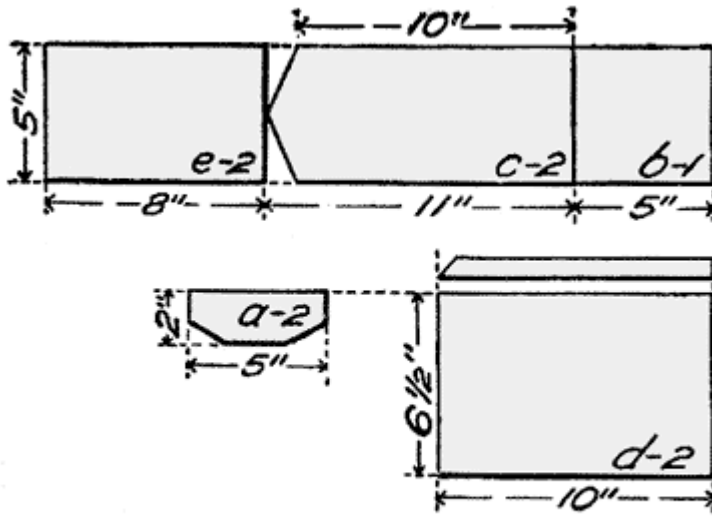
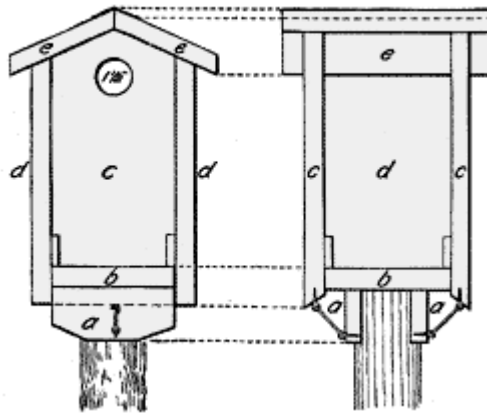

Fig. 18.-Lumber diagrams of house shown in figure 17.
Thickness of boards 3/4 inch.



Bluebirds and wrens, as well as swallows, nest in this style of house though they prefer a deeper cavity. Another pole house is shown in figure 17. This is essentially after the woodpecker model and is suitable for bluebirds. By releasing the hooks which fasten the box to the base, cleaning is easy.

<http://www.freebirdhouseplans.net/>

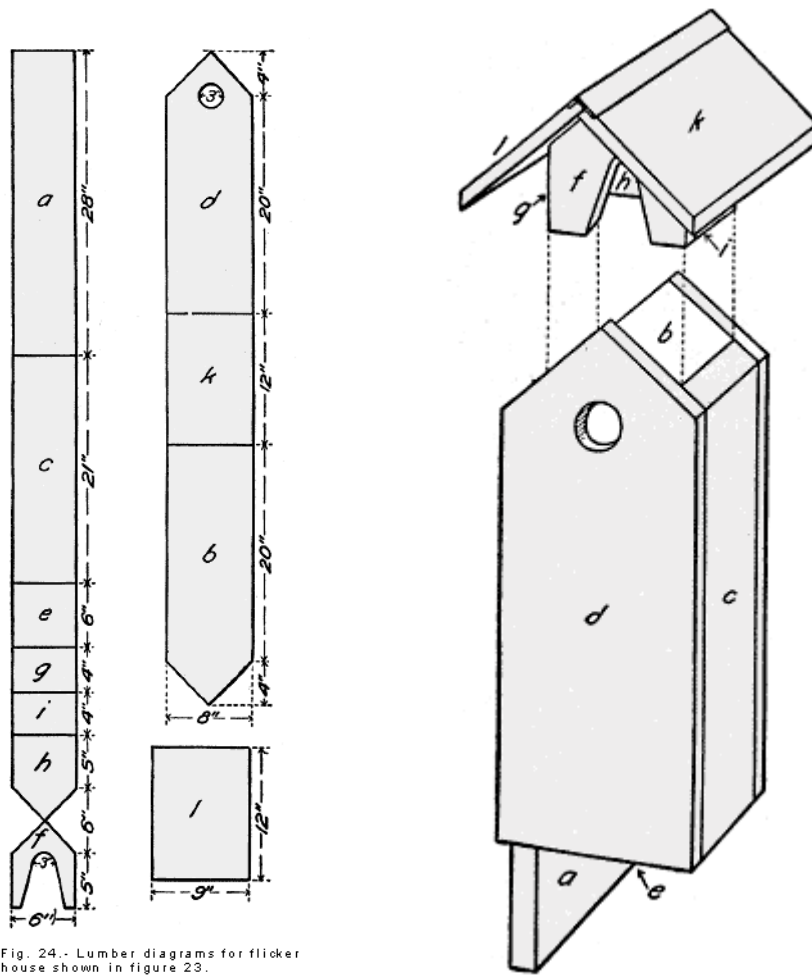
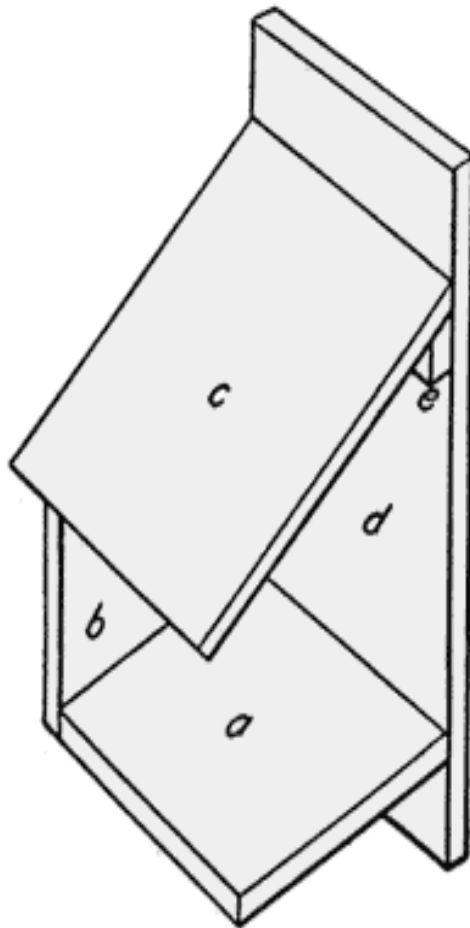

Fig. 24. - Lumber diagrams for flicker house shown in figure 23. Thickness of boards 3/4 inch.

The flicker birdhouse shown in figure 23 is designed to be placed on a post or the stub of a tree. The roof can be lifted in the same way that a stopper is removed from a bottle

<http://www.freebirdhouseplans.net/>



Phoebes like to nest about buildings, and a simple shelf under the - roof of a porch or shed is all they require. If, however, it is desirable to have them stay outside, the shelf must be provided with a roof. Figure 8 shows a shelf shielded from the weather by one wall and a roof. This shelf if placed high under the eaves of a two-story building may attract barn swallows; phoebes and robins also are likely to build upon it if it is not less than 8 feet from the ground. In some cases it will be advisable to leave only one side open.

<http://www.freebirdhouseplans.net/>

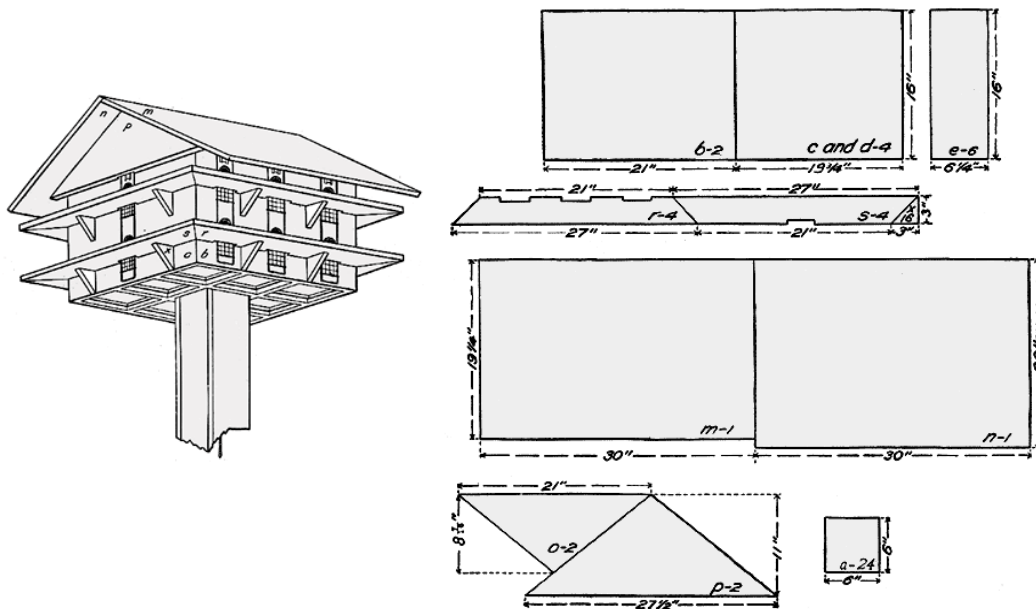

Martin bird houses are built on the apartment plan to satisfy the social instinct so marked in purple martins but so conspicuously lacking in most other birds. They usually contain not less than 10 or 12 rooms and for this reason are relatively complicated, especially if they are miniatures of elaborate buildings, as is often the case. Like the single room houses, they should be easy to inspect and clean from top to bottom and, if possible, should be made proof against the English sparrow. An attempt to combine these essentials in a plain house is illustrated in figure 32. The body of this house slides upon its pole, to the top of which the roof is solidly attached (fig. 36). The pole is hollow and through it runs a cord by which the house is raised and lowered. The floors are all removable by lifting up. When the house is out of contact with the roof all of the entrances are closed by gates actuated by springs, the gates moving upward to close, and being kept down and open by pressure against the roof. By means of this device sparrows may be kept out of the house until martins are due to arrive, or if they get in when the house is open they can be trapped by suddenly lowering it. The pole shown here is made from hardwood boards put together with screws. The concrete base has a core of 2-inch iron pipe which extends upward far enough to make a firm connection with the upper part on which the house slides. A removable heavy weight is employed to hold the house hard against the roof. By passing the cord around the hook of the weight exactly as shown in figure 39 and pulling it upward until the weight is clear of the ground, it can easily be held without slipping while a more secure knot can be tied. A hook less wearing to the cord and fully as serviceable may be made from an acute natural crotch of oak or other hardwood instead of iron. Where this house is exposed to strong winds it may be advisable to attach guy wires to corners of the roof. The pole may be made of a single piece of 4-inch galvanized pipe, set in a concrete base. In this case the house should be a cylinder and the roof a cone.

<http://www.freebirdhouseplans.net/>

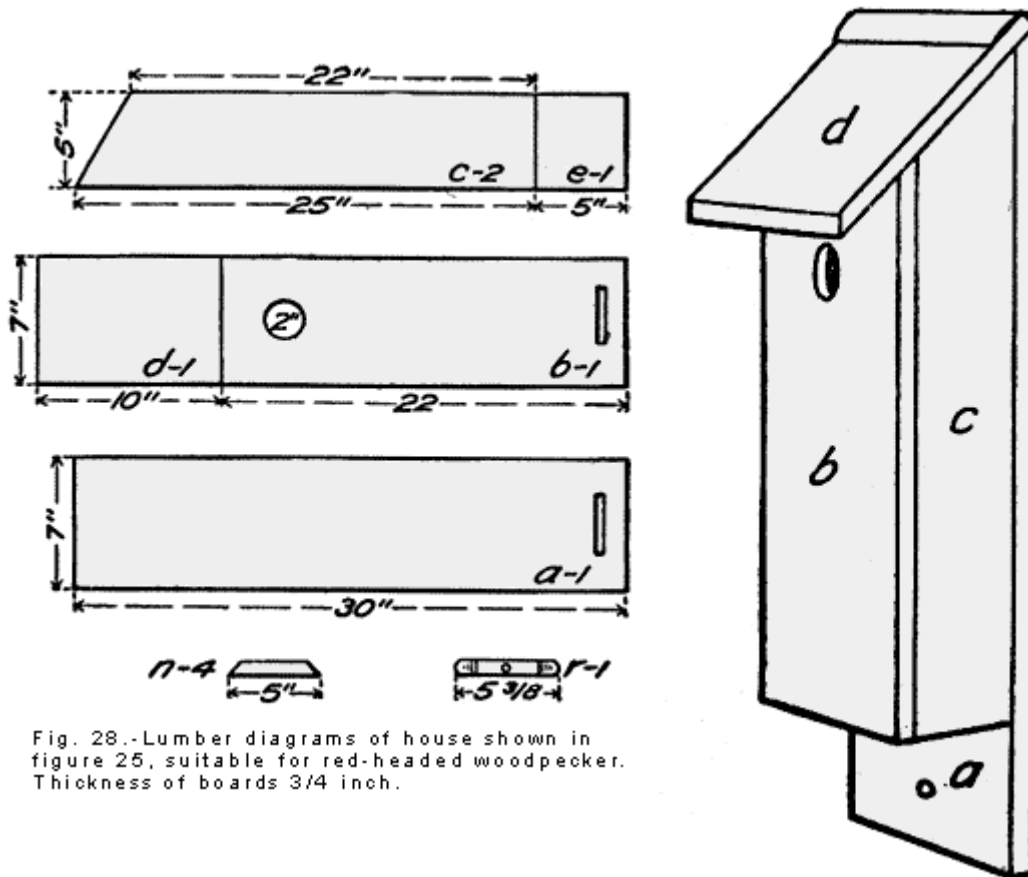

Fig. 28.-Lumber diagrams of house shown in figure 25, suitable for red-headed woodpecker. Thickness of boards $3/4$ inch.

A birdhouse suitable for members of the woodpecker family and also for nuthatches and titmice, including chickadees, is shown in figure 25. It is attached to boles of trees. The bottom is removable, as appears in figure 26. Make sure to provide some ventilation, drill four small $1/4$ inch holes just below the roof. Also provide proper drainage by drilling four small $1/4$ inch holes in the birdhouse floor. Add some grooves or wire mesh below the hole on the inside and make the inside surface rough to make it easier for the birds to get out of the box.

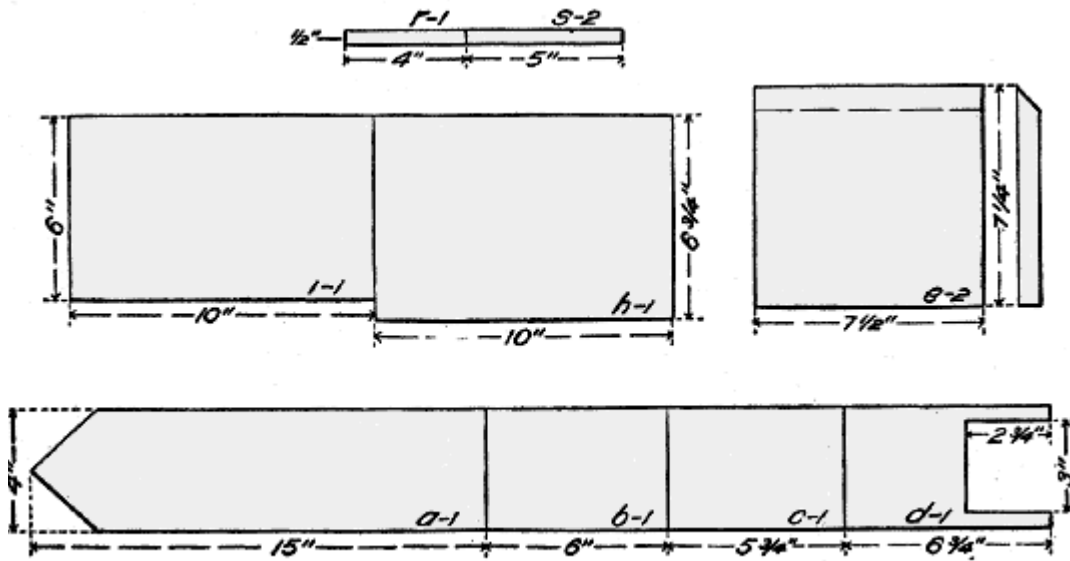

Fig. 31.-Lumber diagrams for house shown in figure 29.
Thickness of boards 3/4 inch.

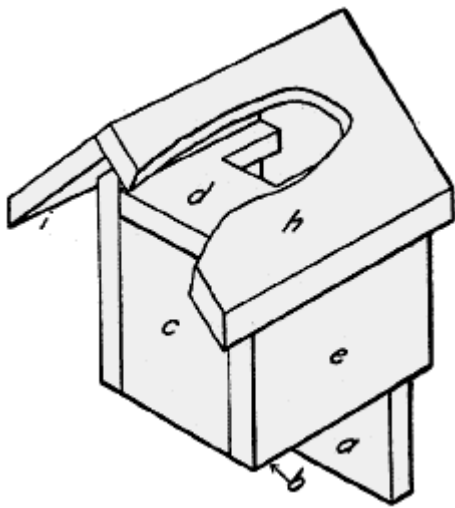

Figure 29 shows a birdhouse designed for wrens and house finches. For wrens it may be placed on a tree or fence post. If attached near the eaves of a building, house finches or wrens will use it. The front gable is open, entrance to the room below being through the rear of the upper floor. This house can be opened for cleaning by lifting out the upper floor.

Introduce IDEX and
what and why I want
to use it in my project
where.

Transplant Storing Residence Heating Greenhouse

WEDNESDAY, NOVEMBER 4, 2009 AT 3:13PM



The Transplant Storing/Residence Heating Greenhouse does exactly that, it is an area where seedlings can be kept safe and it is a source of heat for housing.

The greenhouse is attached to the residence; however air tight doors between the two structures can eliminate heat created by the greenhouse during warm times such as the summer.

Fans may be necessary around the wood stove, depending on what kind of material is used as the greenhouse covering. Fans may also be useful in circulating the warm air throughout the house.

Currently, during the off season, seedlings are started in a greenhouse on WSU campus. Later, transplants are transported from campus to the farm.

Having a greenhouse on site that is usable year-around will decrease labor and increase overall farm greenhouse area.

Heating the greenhouse with a wood stove will decrease energy dependence on other sources such as gas, coal, or oil.

The wood stove will definitely be a great enough source to heat the greenhouse and depending on the size of the residence, might be enough to heat it as well. With this design, there will be no heating bill.

Wood material for the stove should be recycled and can come from extra farm material, donations, recycling centers, etc. Material will be needed scarcely because the sun will be acting as the main energy resource.

Misha Manuchehri

The Wall Machine

TUESDAY, OCTOBER 20, 2009 AT 10:51 PM



The Wall Machine

1. Anaerobic Septic Tank
2. Closed Anoxic Reactor
3. Closed Aerobic Reactor
4. Open Aerobic Tanks
5. Quiescent Clarifier
6. Constructed Wetland
7. Water Storage

The Living Wall, or the Wall Machine is from the concept of a living machine, but retooled so that it can be both architectural, visual, and scaled to a single apparatus.

A living machine is the human constructed natural process that cleans water through bacteria cleansing and filtration.

All the living machines I have researched are very large, requiring a greenhouse and verly large tanks.

Similarly, these living machines filter about 2500 gallons of water a day.

The question was, “do they need to be so big?”

If it could be scaled to lets say a singular toilet, where the person using it is in direct control over their waste and water treatment, then could it perhaps be integrated in a way that is architectural and modular? This is my attempt at doing so.

Brian Neu

A Modular Concept

WEDNESDAY, OCTOBER 7, 2009 AT 1:09PM

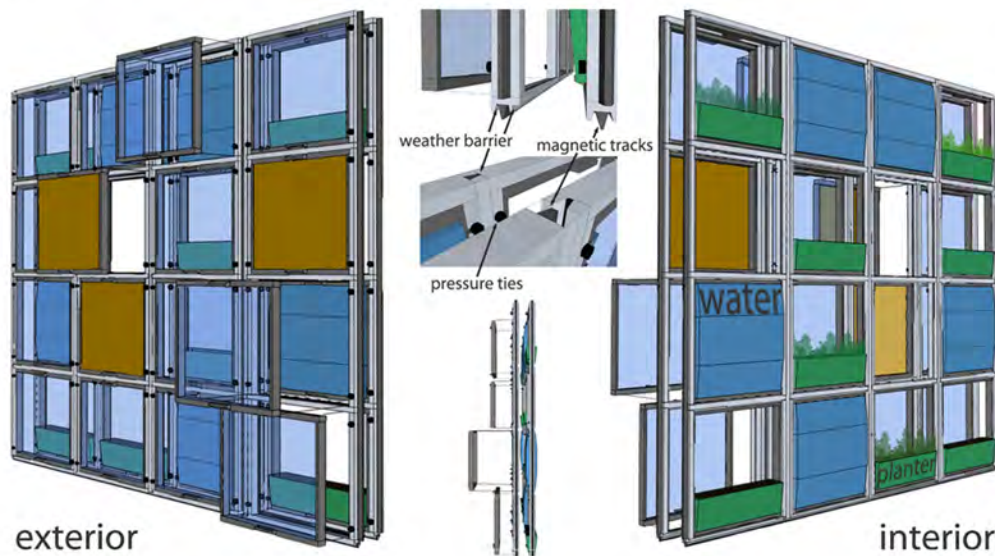

My concept incorporates a living wall (among other things) within a modular system. Circuitry would be incorporated into the two foot wide slider panels which constitutes the

My concept incorporates a living wall (among other things) within a modular system.

Circuitry would be incorporated into the two foot wide slider panels which constitutes the modular dimensional parameters.

The sliding frames incorporate all the weather barriers necessary and the locking mechanisms for the modules.

The frame for the modules themselves would also be a design parameter, but anything within the frame can be designed freely for any necessary use, i.e. storage boxes, fold down counter space, windows, fold out solar panels, fold up shading devices, water tanks, living wall planters, thermal barriers, etc.

The tracks serve several purposes.

First, it could provide all the circuitry for electricity passage into the panels and, secondly, it would provide an opposing electromagnetic current to "levitate" the panels for easy movement down the track for customization.

There could be up to three tracks though only a double wall system is shown in this example.

The water tanks could serve two purposes: water storage for human use and water storage for irrigation of the living wall.

This system could also answer the question I answered from structure + skin (can it be seasonal), in a much more fun, customizable, and perhaps even more efficient way.

Blaine Neu

Multi-Purpose Water

WEDNESDAY, OCTOBER 21, 2009 AT 1:33PM

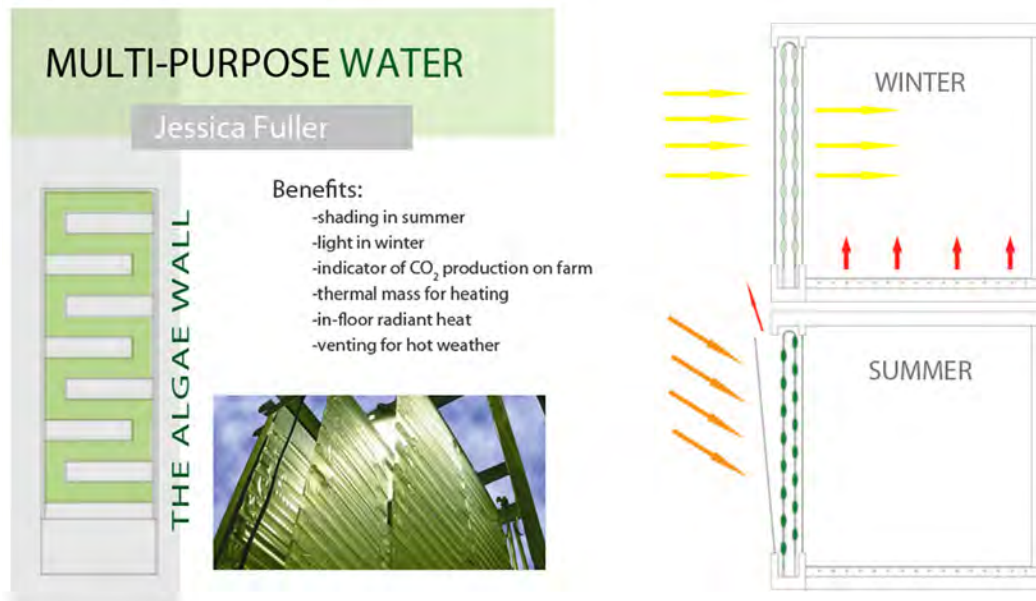

The algae wall system is double-layered and has clear spaces left in it to allow for maximum control of thermal mass, light, and shade.

The wall can be rotated in different seasons to allow more or less light to pass through.

The system can be used to heat a radiant floor system during the day, and has sufficient thermal mass to provide heat at night as well.

In the summer months, the radiant heat can be turned off and the window opened.

The algae wall will provide shade, and the extra heat gain will be let off through the open window to minimize heat gain during warm days.

Since algae thrives on sunlight, the algae will become darker and more dense during the summer months, providing even more shading.

Algae walls are usually maintained at plants where CO₂ is being produced constantly.

Since many farm and agriculture processes produce CO₂, the algae can be fed by farm by-products.

The color and density of algae will then become an indicator of CO₂ production on the farm.

The by-products of this process are biogasses which can be used for a number of things including running engines or converting to electricity.

Jessica Fuller

Algae Energy

WEDNESDAY, NOVEMBER 4, 2009 AT 12:23PM

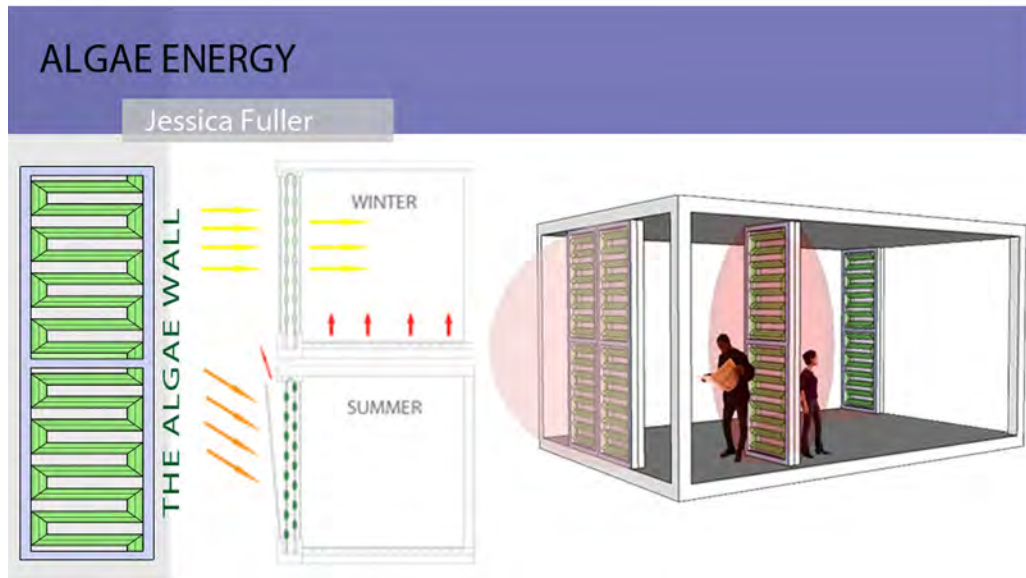

Building on my water idea from last week, I continued with the algae wall. I was exploring the idea of having energy available at the point of its need. To do this with the algae wall I broke the panels into smaller, more manageable pieces. Each panel can slide from one position to another with minimal effort by the user. The two-layered panel still

Building on my water idea from last week, I continued with the algae wall, I was exploring the idea of having energy available at the point of its need.

To do this with the algae wall, I broke the panels into smaller, more manageable pieces.

Each panel can slide from one position to another with minimal effort by the user.

The two-layered panel still provides options for more or less shading and thermal mass, but now it is moveable, as well.

This will allow residents to collect heat during the day (filtering out any unwanted heat and light and moving it to where it is needed at night.

The user could then move the panel closer or farther from them depending on what their needs are.

The algae system can also be used to create biomass and fuel that can be used for mechanical or electrical energy.

Radiant heat tubes are also running through the algae to take heat to create hot water and radiant heat in the flooring.

Jessica Fuller

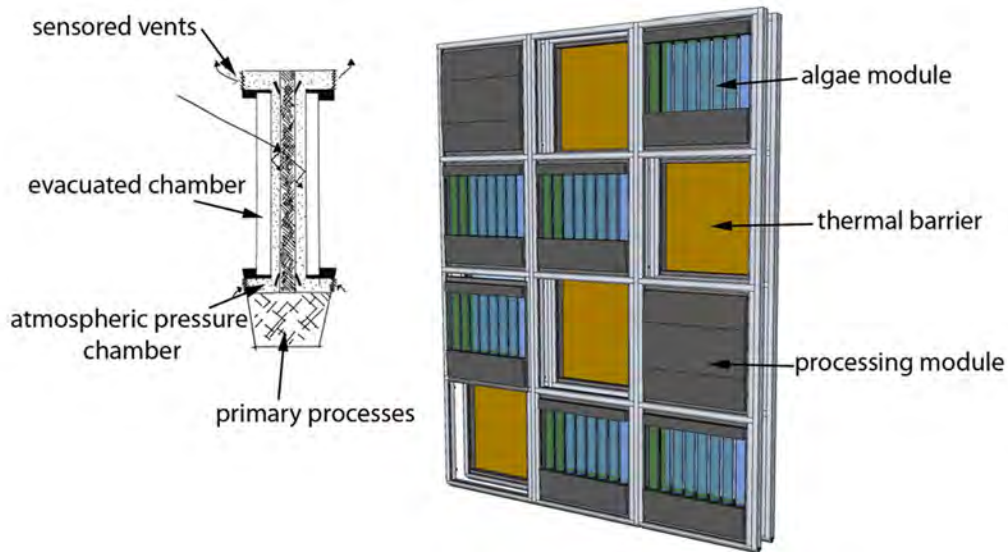

Algae are the common “new thing” for energy production, but that doesn’t mean the application of an innovative new process can’t be innovative itself. Once again taking my module system, I really thought about how and why I would take what is currently only applied to a grand grand scale. Today, what little in algae production is, of course in terms of innovation, built for the larger application of energy production for a scale of perhaps a neighborhood. At least that is where the innovation is taking place—for future grand scale application. Why not take a similar approach to the algae production and scale it to individual use, for instance, powering a microwave or a room. Furthermore, how can we take this system and make it architectural so that the user can be involved in the process at least visually, instead of ignoring the process in a greenhouse or shoving it in a closet.

By modulating the system, we get efficiency through redundancy. It may be expensive to engineer the similar system, but hopefully, through the redundancy and scale of the module, it may pay off quickly on the larger scale of the entire complex. The design of the module takes the idea of an evacuated tube taken from the system concept of Solar Thermal. The evacuated tube would be used to heat up the atmosphere for the algae to produce all year round, but as seen with Solar Thermal, it is too efficient. While water can overheat, the same cannot be said for successful algae production. A secondary atmospheric pressure chamber would be added in between the evacuated chamber and the algae chamber so that heat evacuation may be provided through sensory vents. The unit would be experiential, allowing different light qualities through each tube, differentiated by the density or progression of algae production. When the algae is new growth, it would be less dense and typically lighter (depending on the species), allowing a differentiated experience from the more ambient light of the older growth algae (denser and typically darker).

The preliminary process would happen locally in the module, where the algae is destroyed and fats and sugars are remaining. The fats and sugars would then be taken to a processing module where the more complex processes of separating the fats from the sugars would take place. Also here would be where the “fuel” from the fats would be produced. Lastly, the “fuel” would be converted into electricity locally and put into the grid for use, instead of taking a fuel cell and move it around the house when full. This would simplify the input required by the user. Perhaps if the processing system is “apple” engineered, the module could be glass fronted so that it can be further visually investigated by the user.

Brian Neu

Piezoelectric Walls Convert Wind To Energy

WEDNESDAY, NOVEMBER 4, 2009 AT 10:30AM

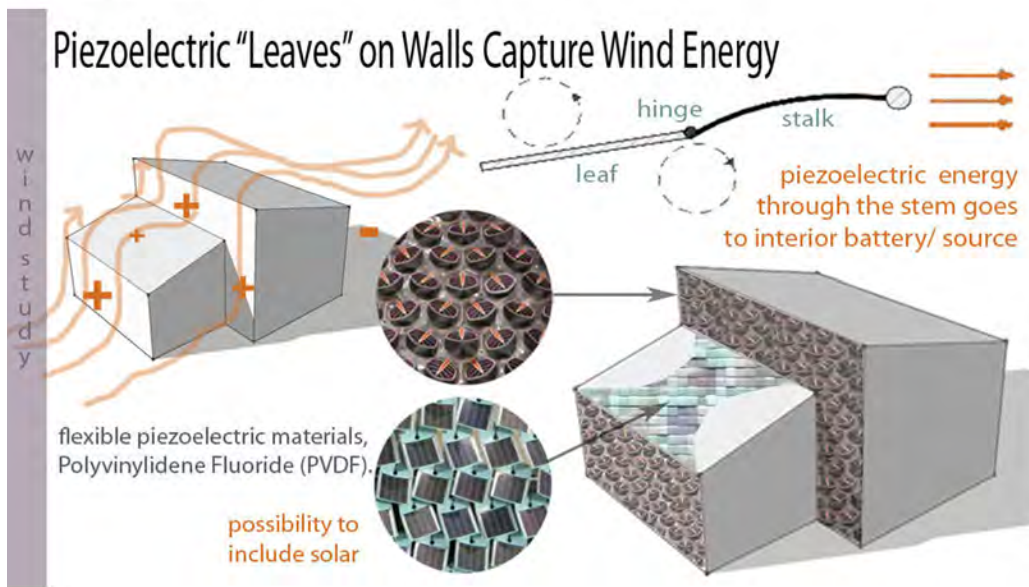

As opposed to wind turbines, there is a need to investigate *harvesting the wind as it flows around our buildings*. Here we see a new consideration to the exterior elements in terms of our building materials and tectonics- and most importantly, energy production. Being on site, especially on the southern acres and on the crest of the hills, one can tell that the wind can become quite strong. The idea that the exterior walls could capture the wind through piezoelectrics is plausible, yet the amount of energy that it could generate is still minimal. *Using the idea of vortex shedding, when the wind hits the walls, it will drive the "leaves" to bend downstream in the air wake allowing us to collect the AC signal from the flapping piezo-leaf.* The flapping motion is attributed to instability of the aero-elastic system, and considering the unpredictable wind strength and diverse outdoor ambient, that is why they would ideally be made out of a flexible piezoelectric material like Polyvinylidene Fluoride (PVDF). Once the AC signal is collected from the leaf, which is working on a periodic bending model, the electrical energy is stored in a capacitor after rectifying it with a full-wave bridge. Based around a modular brick system, the concept implies that each brick would have an allotted amount of "leaves" with a flexible piezo generator at their stem, which would then route the harvested energy to the connected network. Right now the energy generated may be enough to power a light-bulb or two, but over time the power could also be stored in a battery for later use.

Here are some cool sites regarding research on piezoelectrics

<http://ccsl.mae.cornell.edu/node/116> (research on the "leaf" idea by the Cornell Computational Synthesis Laboratory)

<http://peswiki.com/energy/Directory:Piezoelectric> (resources related to energy generation and harvesting using piezoelectric effects)

<http://www.treehugger.com/files/2008/03/grow-solar-piezo-electric-concept.php#ch02> (solar/ piezoelectric concept developed by SMIT for an Industrial Design Thesis; appeared at the MoMA's "Design and Elastic Mind" exhibition in NY in May 2009)

Mackenzie King

Food- A Cyclical System

WEDNESDAY, OCTOBER 7, 2009 AT 1:17PM

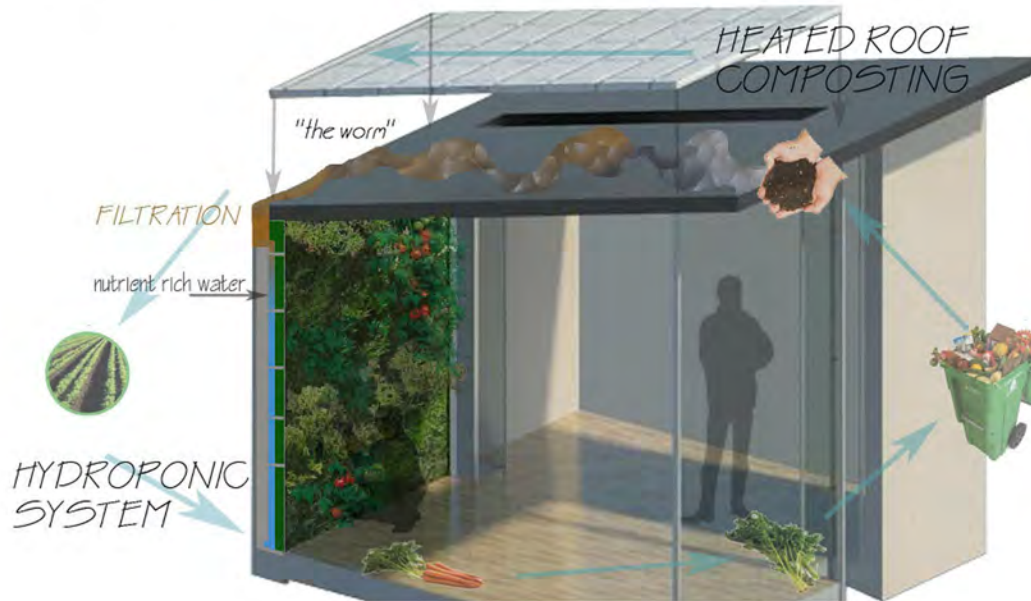

Making the produce, and the remains of the old compost an integrated cycle with the structure is advantages to not only the farm's output, but the building's as well. By taking selective compost, crop remains and monitored soils, it not only clears up space on the site, but uses the building's layering system and heat retention to enable a speedy decomposition.

With that, you could take the layering system of the roof, and sandwich the composting container between the panels to create a controllable temperature zone, using the sun's natural heat to warm the compost to the needed levels. By creating a new type of membrane we allow the waste to naturally rotate and move itself. You would get a peristalsis type effect, much like how your intestines or a worm would move food, using either biometric metals, or even piezoelectricity, as part of the skin fabric (woven into the membrane if possible). With that, energy and heat would cause the skin to move and contract in a way that would rotate and move the compost down the roof until it reached the final filtering stage. In the above image the filter is placed at the end of the "worm" system, and would feed into the hydroponic water system for the vertical farm.

If applied correctly, you would be able to derive nutrients from the compost and then feed them into the water (similar to what is called the "Nutrient Film Technique (NFT)"). Since hydroponics don't involve soils, nutrient-rich water is what sustains these living interior crops. A pump, along with optional timers and sensor controls, would then cycle through the water to the bed in which the crops are planted (from the case studies looked at, organic farming did seem a plausible option for this system, although it is a bit harder to accomplish because extra monitoring is required to meet organic codes).

One suggestion for this "bed," instead of soil, is Rockwool, which is simply ground up rock that is spun into threads making wool. This material is very light and often sold in cubes, making it easy to install, fitting nicely into the back grid-system in the wall, and also has a lot of space for air in between the little threads (so no matter how much water is present, the plants won't be overwatered). Serving as insulation to the house, and the plants, the rockwool has little effect on the cation exchange, except for a small effect on pH, and is long-lasting and biodegradable.

Sensing devices would be very beneficial in monitoring the nutrient levels and electro conductivity (within the hydroponic system, as well as temperature, humidity and things like carbon dioxide in the composting-roof system. Constant monitoring must occur so the first group of elements do not build up, which is very toxic to plant tissue. Yet the proposal here is not to complicate our system of food production, but to incorporate it on yet another cyclical level so that waste is minimal. With that, the overall design for the site would integrate the new, and old, principles of WSU's organic farm on a modern level.

Mackenzie King

Micro-Hydro-Turbine

WEDNESDAY, NOVEMBER 4, 2009 AT 1:08PM

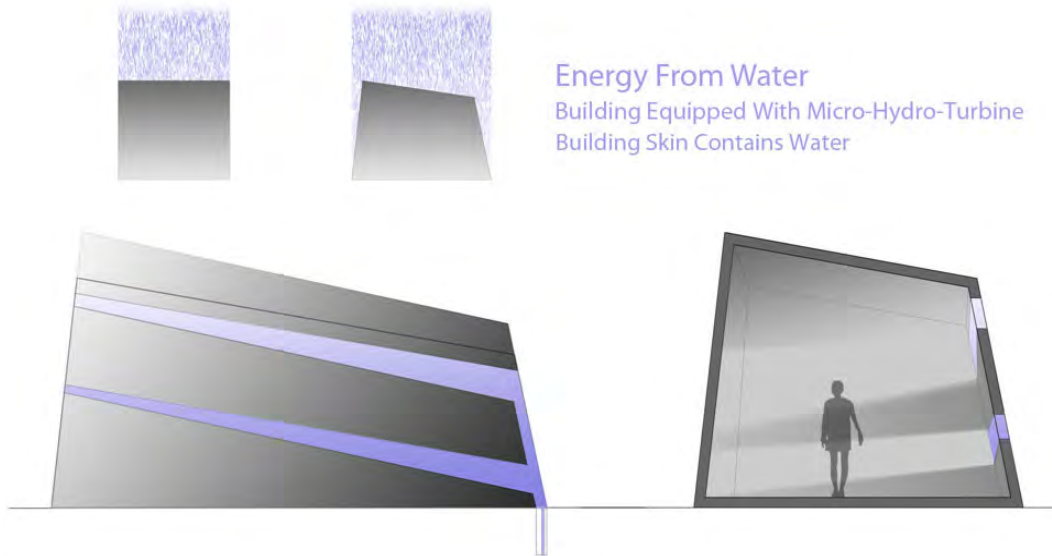

The idea here is for the skin of the building to hold rainwater that can then flow through a micro-hydro-turbine to generate electricity.

The form of the building is influenced to facilitate in capturing rainwater.

The water could be contained in the skin of the building and enhance the experiential quality of the space.

Jonathan Follett

Growing Food And Providing Shade

WEDNESDAY, OCTOBER 7, 2009 AT 1:03PM



The footprint of a building takes up land that could be farmed.

Losing this space drastically impacts the production of the farm.

This land could be recreated in the form of planters that could surround a building.

By providing a simple **structure system for the planting trays**, this system could provide the same growing area or more, than what the building footprint takes up.

This system would also provide shade for a building and could be thought of as a **“food producing skin.”**

Also, this system could be mechanized and operate with the growing season.

For example new plants could start out on the south side, and then mature as they move along the roof and harvesting could take place on the north side.

Jon Follett

Redevelopment Guidelines

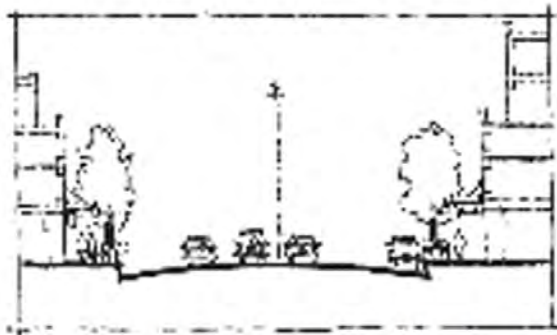
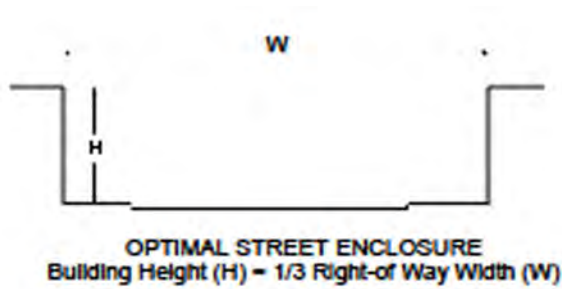

Recessing stories above the 5th floor of developments on arterials maintains natural light on the street and minimizes the impact of height on pedestrians.

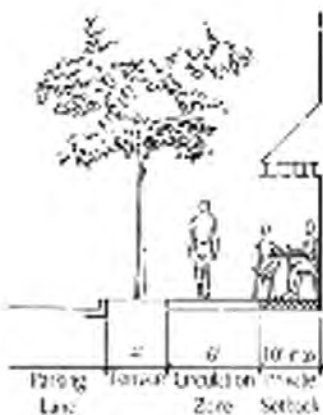

Building setbacks can provide space for outdoor cafes and landscaping.

BUILDING SCALE

The scale of a building has an important influence on the character of a place.

Recommendations for the scale of a new structure and its design elements should reflect the goals of the North Barstow Redevelopment Study and the desired character objectives for the area.

Scale should be pedestrian-oriented and appropriate to the orientation of the street.

No large-scale surface parking will be allowed

BUILDING SITING

The siting of a new building should:

Be conducive to pedestrian use

Have no more than a 10' setback

Locate service and parking areas to functional, yet unobtrusive locations

"North Barstow Area Redevelopment: Architectural Design Guidelines" February 2005. Date accessed: 4/17/2010. <http://www.eaclairedevelopment.com/docs/Architectural%20Design%20Guidelines.pdf>

Rear parking areas and entrances should contain pedestrian friendly amenities such as lighting, benches, landscaping, walkways, directory signage, etc.

Multiple walkways through parking lot and landscaping connect the site to the adjacent street(s) and create smaller parking areas in place of one large parking lot.

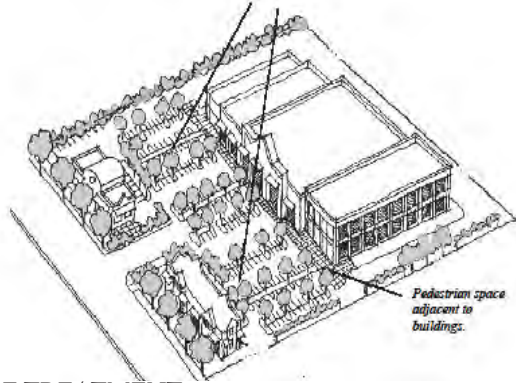

PARKING

Parking lots are discouraged in front of buildings.

Rear lot parking should be used.

Any Parking adjacent to the street should be perpendicular or angled parking--not parallel.

Pave, stripe, and light all parking areas.

Provide bicycle parking racks at public lots.

FACADE TREATMENT

Building facades should add to the vitality and pedestrian scale of the area.

The storefront is the street level portion of the building facade and is the most important architectural part of commercial buildings since customers tend to focus their attention on this part of the building first.

Storefronts should be composed largely of glass to expose store activity to pedestrians on the street and allow natural light into stores.

The cornice is the projected moulding at the uppermost termination of the building facade.

Cornices are one of the key design features of buildings in central business districts.

The addition of a simple cornice to a building will help the building fit better into the overall context of the street.

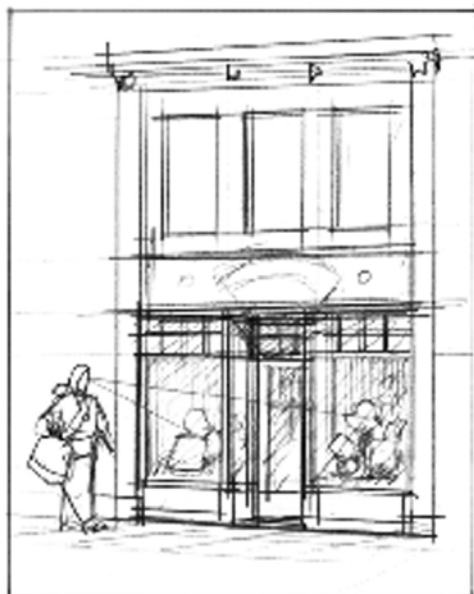

MATERIALS & COLOR

Afer scale and form, materials and color create the greatest impression and determine how a building will blend with its neighbors.

Buildings that experience pedestrian contact should be constructed of smaller scaled materials such as brick, etc.

Limestone and brick are recommended construction materials because of their traditional use in Eau Claire, their durability, and scale.

Colors should be chosen from a palatte that offers variety, yet, excludes radical deviations.

LEED

Project Totals (Certification Estimates)		110	Points
Not Certified	Certified: 40-49 points Silver: 50-59 points Gold: 60-79 points Platinum: 80+ points		

Impacts of US Buildings on Resources:

40%	primary energy use
72%	electricity consumption
39%	co ₂ emissions
13.6%	potable water consumption
75%	landfill space with construction and demolition debris
14%	freshwater resources
10-15° F	heat increase in urban areas as compared to surrounding suburbs due to heat island effect

LEED Catagories

- Sustainable Sites
- Water Efficiency
- Energy & Atmosphere
- Materials & Resources
- Indoor Environmental Quality
- Innovation & Design
- Regional Priority



Eau Claire is located in wind Zone I.

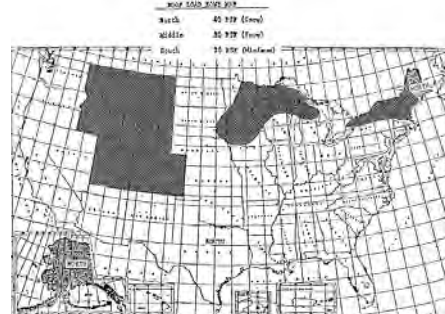

Eau Claire is located in the middle snow zone, thus requiring that roofs be capable of supporting a dead load of 30 psi.

(c) Wind, snow, and roof loads—(1) Wind loads—design requirements. (i) Standard wind loads (Zone I). When a manufactured home is not designed to resist the wind loads for high wind areas (Zone II or Zone III) specified in paragraph (c)(1)(ii) of this section, the manufactured home and each of its wind resisting parts and portions shall be designed for horizontal wind loads of not less than 15 psf and net uplift load of not less than 9 psf.

(iii) Eaves and cornices shall be designed for a net uplift pressure of 2.5 times the design uplift wind pressure cited in §3280.305(c)(1)(i) for Wind Zone I.

(iv) Skylights must be capable of withstanding roof loads as specified in paragraphs (c)(3)(i) or (c)(3)(ii) of this section. Skylights must be listed and tested in accordance with AAMA 1600/I.S.7-00, 2003, Voluntary Specification for Skylights

(d) Design load deflection. (1) When a structural assembly is subjected to total design live loads, the deflection for structural framing members shall not exceed the following (where L equals the clear span between supports or two times the length of a cantilever):

Floor— $L/240$

Roof and ceiling— $L/180$

Headers, beams, and girders (vertical load)— $L/180$

Walls and partitions— $L/180$

(2) The allowable eave or cornice deflection for uplift is to be measured at the design uplift load of 9 psf for Wind Zone I, and at the design uplift pressure cited in paragraph (c)(1)(ii) of this section for Wind Zones II and III. The allowable deflection shall be $(2 \times L_c)/180$, where L_c is the measured horizontal eave projection from the wall.

(e) Fastening of structural systems. (1) Roof framing must be securely fastened to wall framing, walls to floor structure, and floor structure to chassis, to secure and maintain continuity between the floor and chassis in order to resist wind overturning, uplift, and sliding, and to provide continuous load paths for these forces to the foundation or anchorage system. The number and type of fasteners used must be capable of transferring all forces between elements being joined.

(f) Walls. The walls shall be of sufficient strength to withstand the load requirements as defined in §3280.305(c) of this part, without exceeding the deflections as specified in §3280.305(d). The connections between the bearing walls, floor, and roof framework members shall be fabricated in such a manner as to provide support for the material used to enclose the manufactured home and to provide for transfer of all lateral and vertical loads to the floor and chassis.

(2) Interior walls and partitions shall be constructed with structural capacity adequate for the intended purpose and shall be capable of resisting a horizontal load of not less than five pounds per square foot. An allowable stress increase of 1.33 times the permitted published design values may be used in the design of wood framed interior partitions. Finish of walls and partitions shall be securely fastened to wall framing.

(g) Floors. (1) Floor assemblies shall be designed in accordance with accepted engineering practice standards to support a minimum uniform live load of 40 lb/ft² plus the dead load of the materials. In addition (but not simultaneously), floors shall be able to support a 200-pound concentrated load on a one-inch diameter disc at the most critical location with a maximum deflection not to exceed one-eighth inch relative to floor framing. Perimeter wood joists of more than six inches depth shall be stabilized against overturning from superimposed loads as follows: at ends by solid blocking not less than two-inch thickness by full depth of joist, or by connecting to a continuous header not less than two-inch thickness and not less than the depth of the joist with connecting devices; at eight-foot maximum intermediate spacing by solid blocking or by wood cross-bridging of not less than one inch by three inches, metal cross-bridging of equal strength, or by other approved methods.

(h) Roofs. (1) Roofs shall be of sufficient strength to withstand the load requirements as defined in §3280.305 (b) and (c) without exceeding the deflections specified in §3280.305(d). The connections between roof framework members and bearing walls shall be fabricated in such a manner to provide for the transfer of design vertical and horizontal loads to the bearing walls and to resist uplift forces.

Ching, Francis D.K. & Winkel, Steven R. *Building Codes Illustrated* Hoboken, NJ: John Wiley & Sons, Inc. 2003.

Performance space will foster interaction among the residents. It will also promote connections to the surrounding community. This falls under the occupancy group A-1.

Offices, as well as Home Offices, fall under the occupancy group B.

Retail falls under occupancy group M.

Day Care facilities fall under occupancy group E.

Apartments fall under occupancy group R-2.

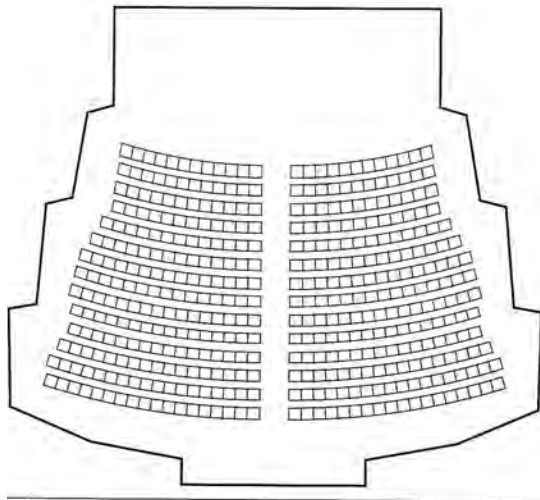

Assembly Group A

Group A-1 is assembly areas, usually with fixed seats, intended for the viewing of performing arts or motion pictures. The presence or absence of a stage is not a distinguishing feature. Most uses classified in this occupancy will have fixed seats. The egress requirements in Group A-1 occupancies recognize that light levels may be low and that people may panic in emergency situations under such circumstances.

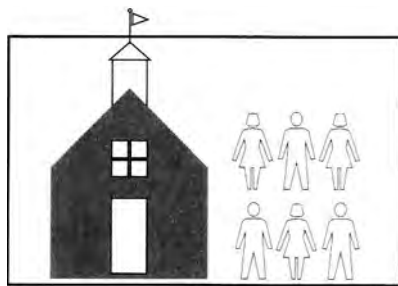

Educational Group E

Group E occupancies are used by six or more people for classes up to the 12th grade. Uses for the day care of five or more children over 2 1/2 years of age make up a subgroup of Group E occupancies. Those uses with fewer than five children are classified as Group R-3.

Assembly uses in school facilities are not excluded from this use group. However, most schools use their large rooms for assembly uses. Such facilities should be examined in light of Assembly Group A occupancy requirements.

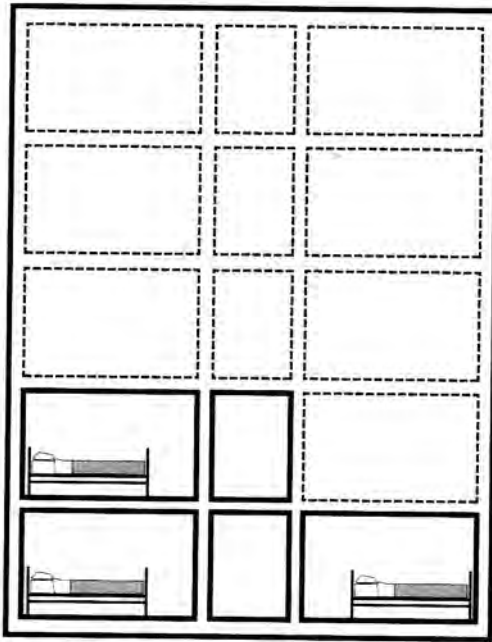

Residential Group R

Group R-2 occupants are permanent, sleeping in more than two dwelling units for more than 30 days. These include apartments, dormitories and long-term residential boarding houses.



Mercantile Group M



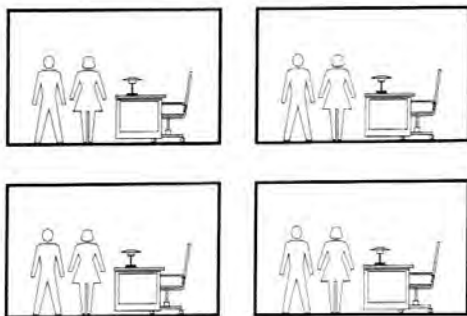







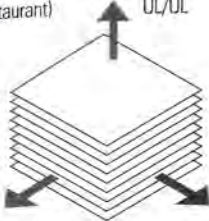



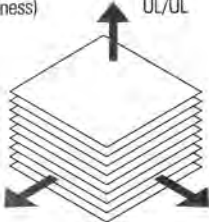
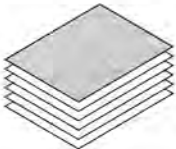

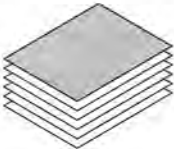
Uses in these groups are fairly self-explanatory. The occupancy group includes incidental storage of up to 10% of the total floor area considered as part of the same occupancy group. Larger storage areas would be classified as Group S. Most retail facilities, no matter what merchandise they sell, fall into this occupancy.

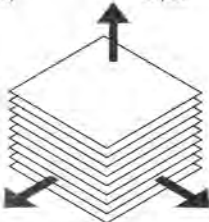

Business Group B

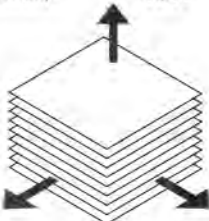
Office buildings are typically classified as Group B occupancies. Storage areas for offices, such as back-office file rooms do not constitute a separate occupancy... Educational facilities for junior colleges, universities and continuing education for classes above the 12th grade are considered Group B occupancies, not Group E. Assembly rooms for these facilities should be examined for conformance with the criteria for Group A occupancy.

Excerpt from IBC Table 503 (Showing Allowable Number of Floors and Proportionate Floor Areas)

Construction Type (See Table 601)	Type I A Fire-Rated	Type II A Fire-Rated	Type III B Nonrated	Type IV Heavy Timber	Type V B Nonrated
Occupancy					
A-2 (Restaurant)	UL/UL 	3/15,500 sf 3/(1440 m ²) 	2/9,500 sf 2/(883 m ²) 	3/15,000 sf 3/(1394 m ²) 	1/6,000 sf 1/(557 m ²) 
B (Business)	UL/UL 	5/37,500 sf 5/(3484 m ²) 	4/19,000 sf 4/(1765 m ²) 	5/36,000 sf 5/(3344 m ²) 	2/9,000 sf 2/(836 m ²) 
M (Retail)	UL/UL 	4/21,500 sf 4/(1997 m ²) 	4/12,500 sf 4/(1161 m ²) 	4/20,500 sf 4/(1904 m ²) 	1/9,000 sf 1/(836 m ²) 
R-2 (Apartment)	UL/UL 	4/24,000 sf 4/(2230 m ²) 	4/16,000 sf 4/(1486 m ²) 	4/20,500 sf 4/(1904 m ²) 	2/7,000 sf 2/(650 m ²) 

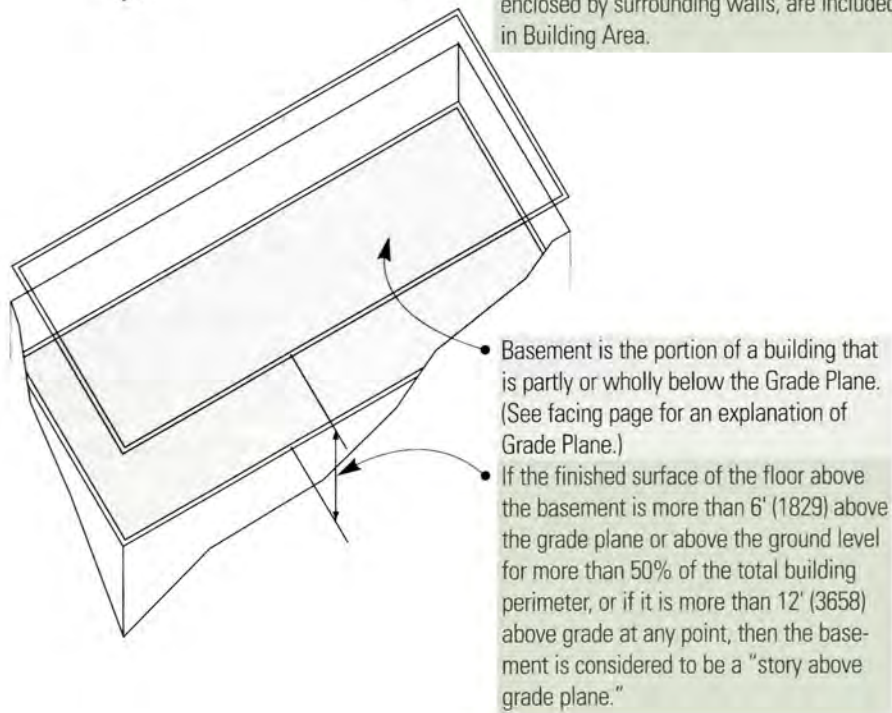
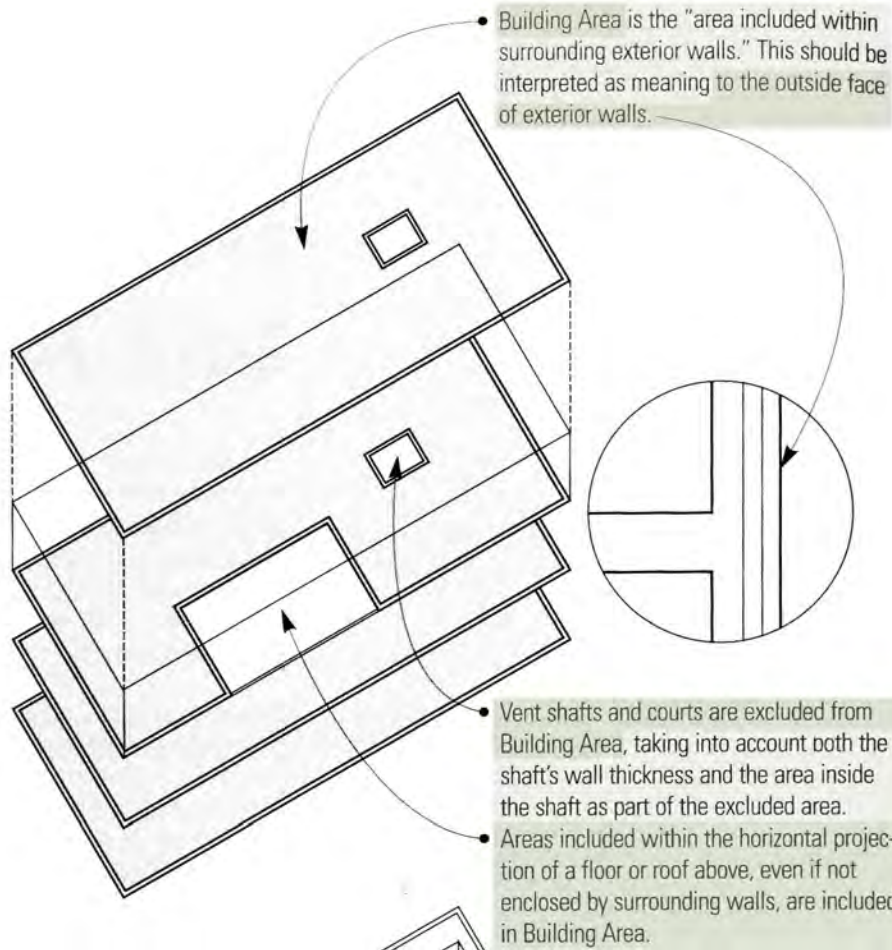

MEZZANINES

§ 505 considers mezzanines that meet the definition in § 502 to be part of the floor below them. If they meet the criteria limiting their area to one-third of the floor below, then they are not considered part of the overall building area, or as an additional story. However, the area must be counted toward the overall fire area as defined in § 702.

The top diagram shows a rectangular room with a mezzanine on the right side. A horizontal dimension line at the top is labeled 'Room Area'. A smaller horizontal dimension line on the mezzanine is labeled '1/3 Room Area'. A staircase is shown on the left side of the room. The bottom diagram shows a similar room with a mezzanine. A railing is shown along the edge of the mezzanine. A double-headed arrow indicates the width of the railing. A single-headed arrow points to the railing. A double-headed arrow indicates the width of the room. A single-headed arrow points to the railing. A double-headed arrow indicates the width of the mezzanine. A single-headed arrow points to the railing. A double-headed arrow indicates the width of the room. A single-headed arrow points to the railing.

- Mezzanines are limited by definition in § 502, and reiterated in this section, to one-third of the area of the space in which they are located. Such a mezzanine is not only excluded from the overall area but also from the total floor-area calculation for the room containing the mezzanine. Thus a 1,000 sf (93 m²) floor space can typically have a 333 sf (31 m²) mezzanine.
- Type I and II buildings housing special industrial occupancies get a bonus allowing the mezzanine to be up to two-thirds of the floor area.
- Mezzanines must be of habitable height, having a minimum of 7' (2134) clear headroom at the mezzanine level as well as in the floor area under the mezzanine.
- Enclosed portions of rooms are not included when determining the size of the room in which a mezzanine is located.
- Mezzanines are required to have two separate means of egress. This is typical except in certain conditions where there is a low occupant load, or if common paths of egress travel are very short. These limitations must be examined together in light of egress requirements in Chapter 10 of the Code.
- Mezzanines are conceived of by the Code as open areas set above other spaces in a room. The code makes an absolute sounding statement that all mezzanines shall be open and unobstructed to the room in which they are located, except for a railing-height wall at the edge. The statement is then followed by numerous exceptions. The basic idea is that if the mezzanine is small in area or occupant load, or is furnished with a clearly defined separate exit path, it may be enclosed.

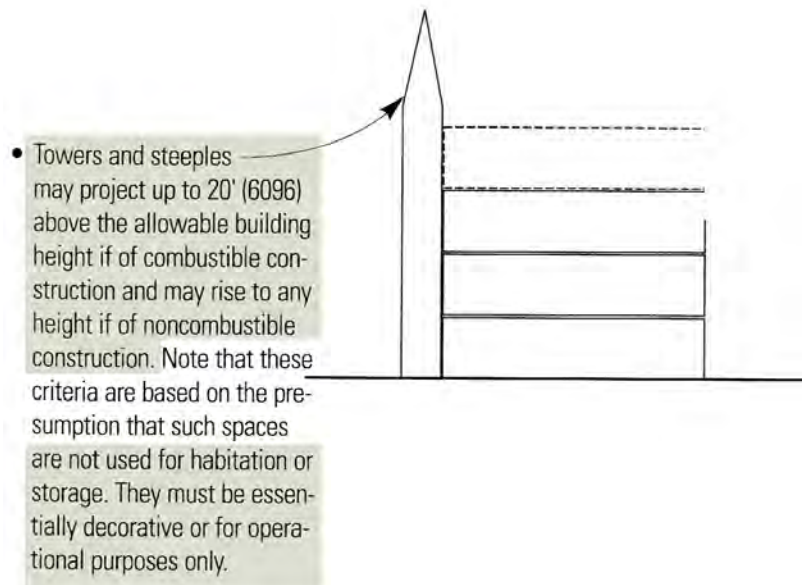
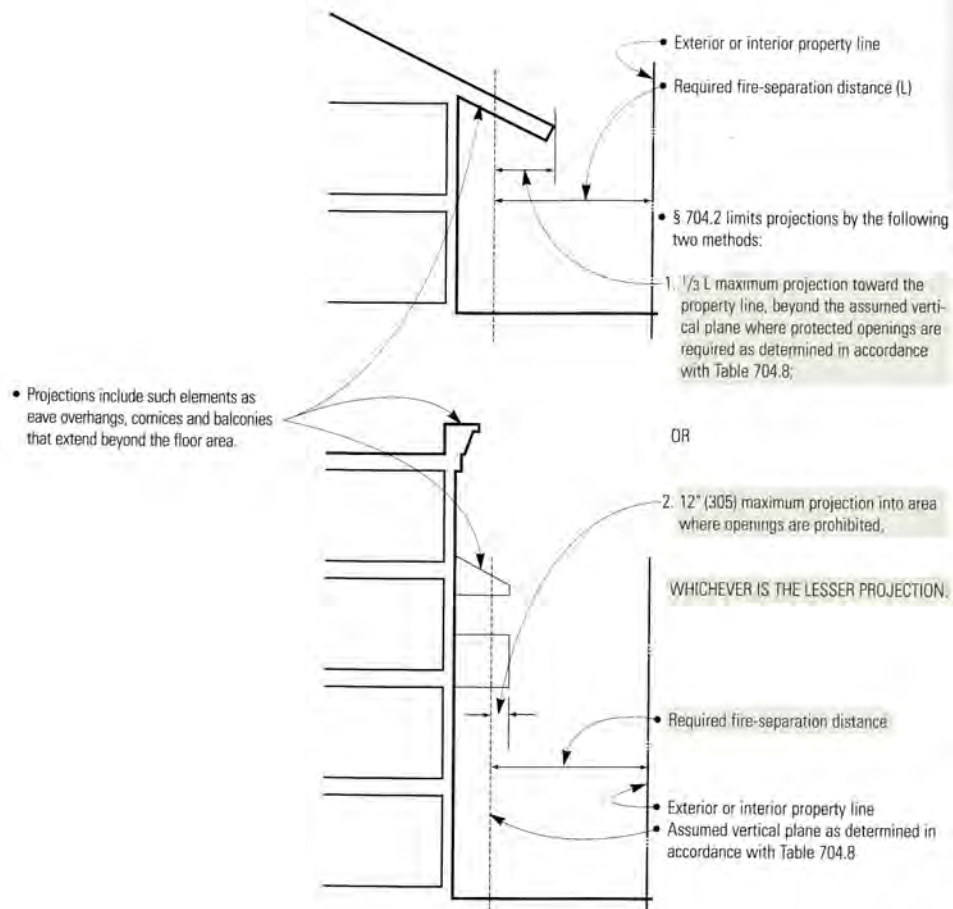

Occupancy	Per Table 1005.2.1				Per Section 1004.2.5	
	Maximum Occupant Load w/ 1 Exit	Minimum No. of Occupants with 2 Exits	No. of Occupants Requiring 3 Exits	No. of Occupants Requiring 4 Exits	Length of Common Path-of-Egress Travel** before 2 Paths of Egress Travel are Required	
All	—	Up to 500	501–1,000	> 1,000	Nonsprinklered	Sprinklered
A, E	50	51–500	"	"	75 (22 860)	75
B, F	50	51–500	"	"	75*	100
H-1, 2, 3	3	4–500	"	"	25 (7620)	25
H-4, 5	10	11–500	"	"	75	75
I-1	10	11–500	"	"	75	75
I-2	Per § 1004.2.3.2	1–500	"	"	75	75
I-3	10	11–500	"	"	100 (30 480)	100
I-4	10	11–500	"	"	75	75
M	50	51–500	"	"	75	75
R	10	11–500	"	"	75	75
S	30	31–500	"	"	75*	100
U	50	51–500	"	"	75*	75*

* Tenant spaces with an occupant load of less than 30 may have a common path-of-egress travel up to 100 feet (30 480).

**See illustration on page 167.

Occupancy	Corridor Required for Occupant Load	Fire-Resistance Rating Without Sprinklers	Fire-Resistance Rating With Sprinklers	Notes	Dead-End Distance [20' (6096) typical]	Minimum Corridor Width Per Table 1003.2.3; 44" (1118) typical
A, B, F, M, S, U	>30	1	0	No rating in open parking garages	50' (15 240) @ B & F when sprinklered	
E	>30	1	0	No rating if one door opens to outside		72" (1829) when occupant capacity >100
R	>10	1	1	No rating at corridors inside dwelling unit or guestroom		36" (914) within dwelling unit
All					Unlimited when dead-end is less than 2 1/2 times corridor width	24" (610) typical for mechanical access; 36" (914) with < 50 occupants

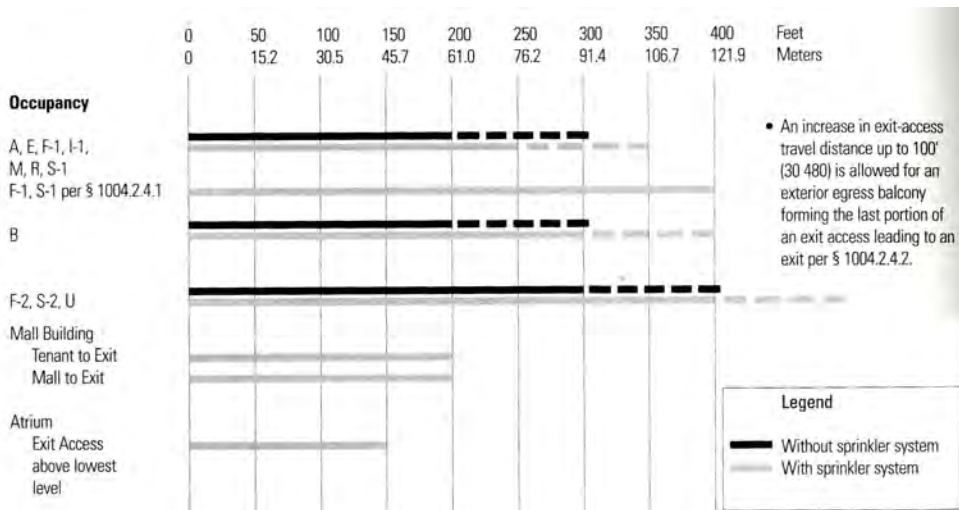

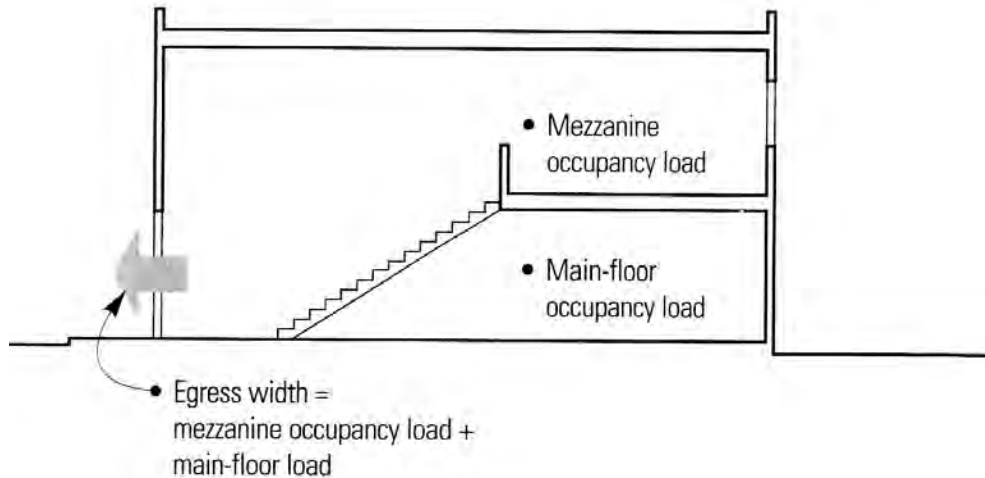
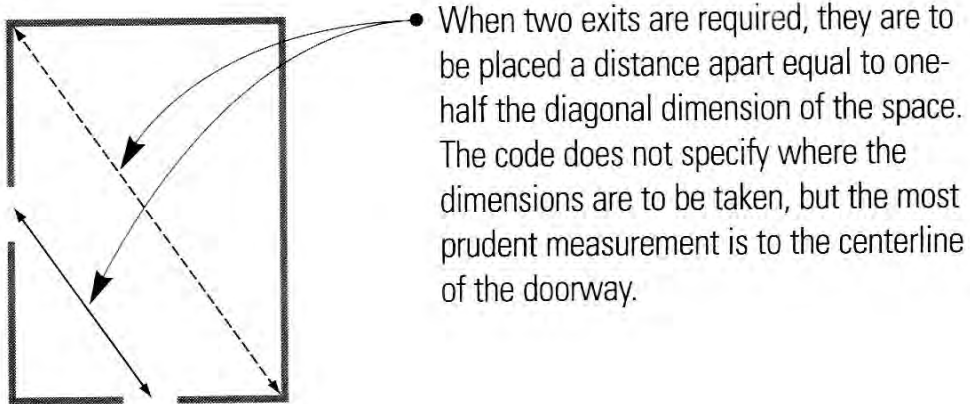
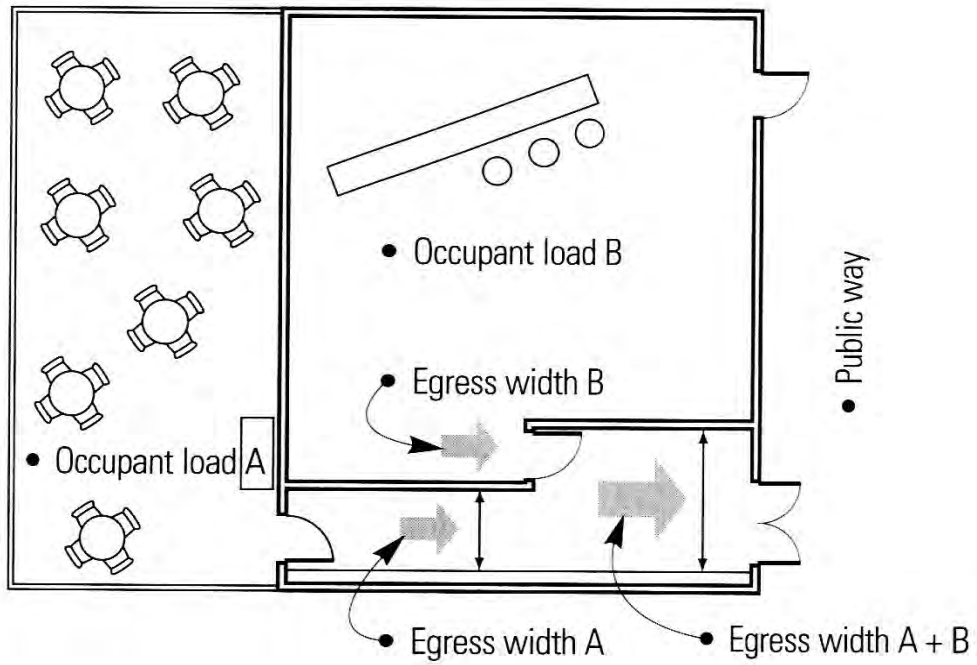

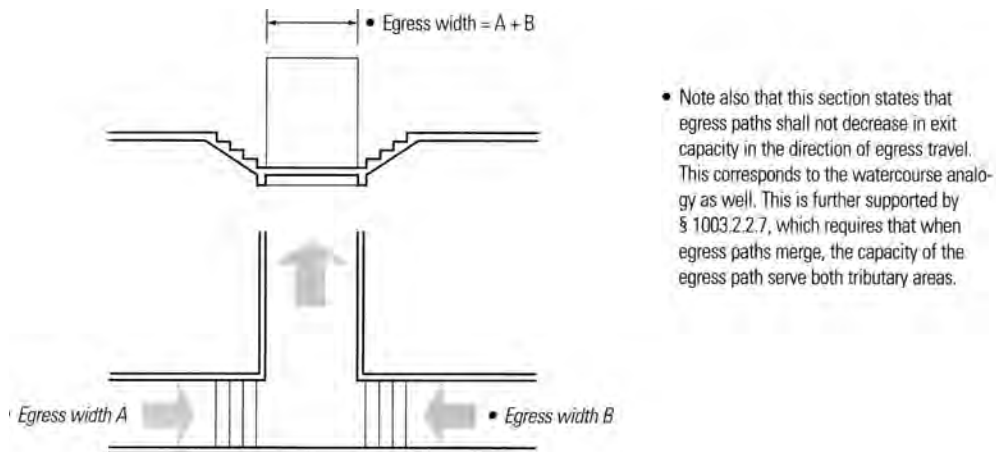
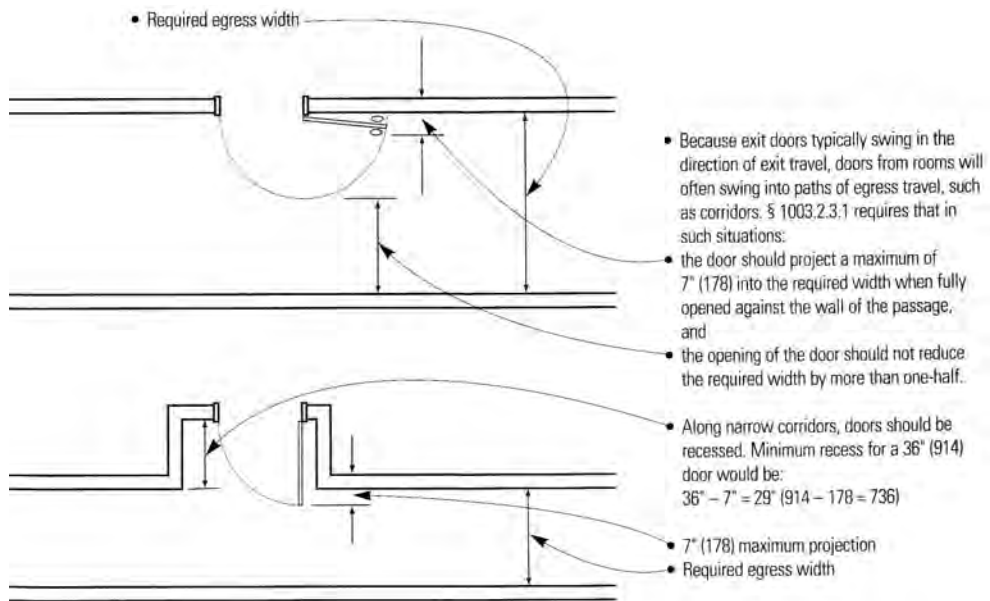
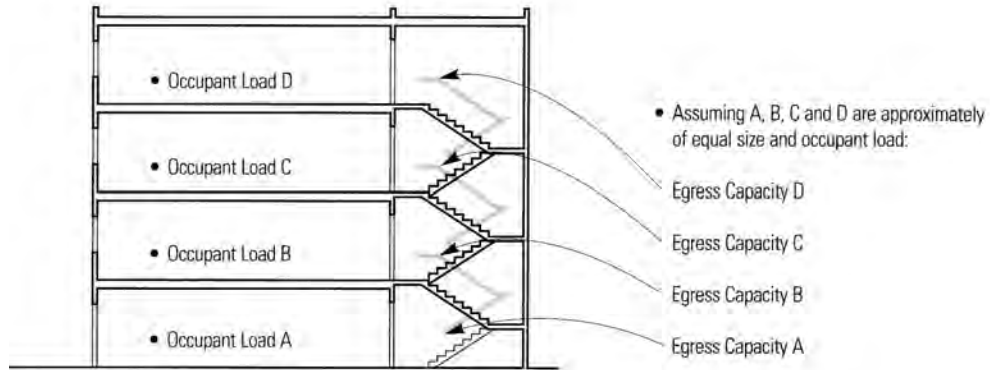

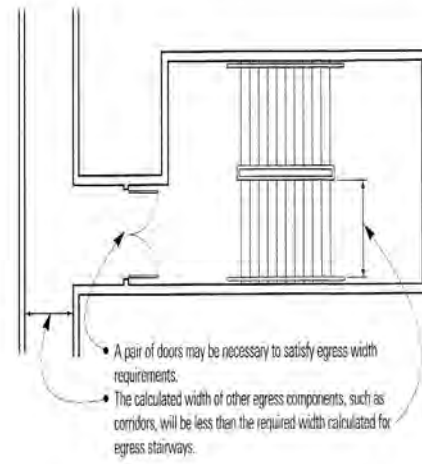

- Stairs are required to provide more width than corridors since people move more slowly in stairways than in corridors or passages. Thus a corridor with a given occupant capacity will be narrower than a stair in the same egress system.
- The table also requires greater egress widths for hazardous occupancies, recognizing the increased hazards in such occupancies.
- It also requires wider egress paths in institutional occupancies, recognizing the need for moving bedridden patients and the fact that occupants are often not fully capable of mobility or cognizant enough for self-preservation without assistance.
- The table also gives credit for provision of sprinklers by reducing the egress widths in sprinklered buildings.

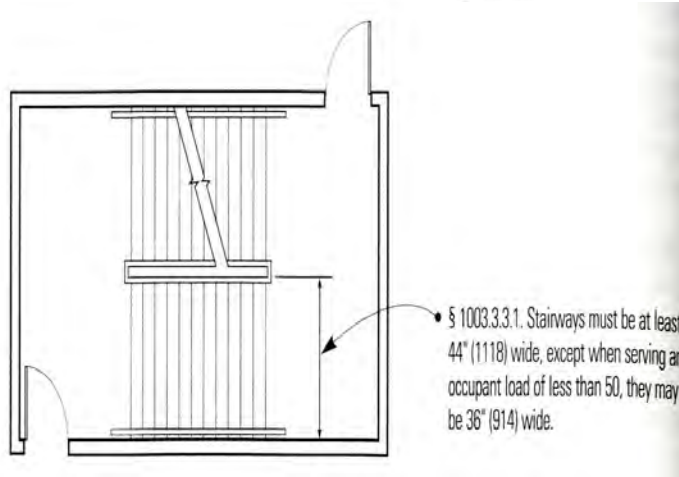

Stairs are required to provide more width than corridors since people move more slowly in stairways than in corridors or passages. Thus a corridor with a given occupant capacity will be narrower than a stair in the same egress system.

The table also requires greater egress widths for hazardous occupancies, recognizing the increased hazards in such occupancies.

It also requires wider egress paths in institutional occupancies, recognizing the need for moving bedridden patients and the fact that occupants are often not fully capable of mobility or cognizant enough for self-preservation without assistance.

The table also gives credit for provision of sprinklers by reducing the egress widths in sprinklered buildings.

Stairways must be at least 44" wide, except when serving an occupant load of less than 50, they may be 36" wide.

Guards

§ 1003.2.12 requires that railings or similar protective elements be provided where any grade change of 30" (762) or more occurs in a means of egress. This also applies when a means of egress is adjacent to glazing elements that do not comply with the strength requirements for railings and guards per § 1607.7.

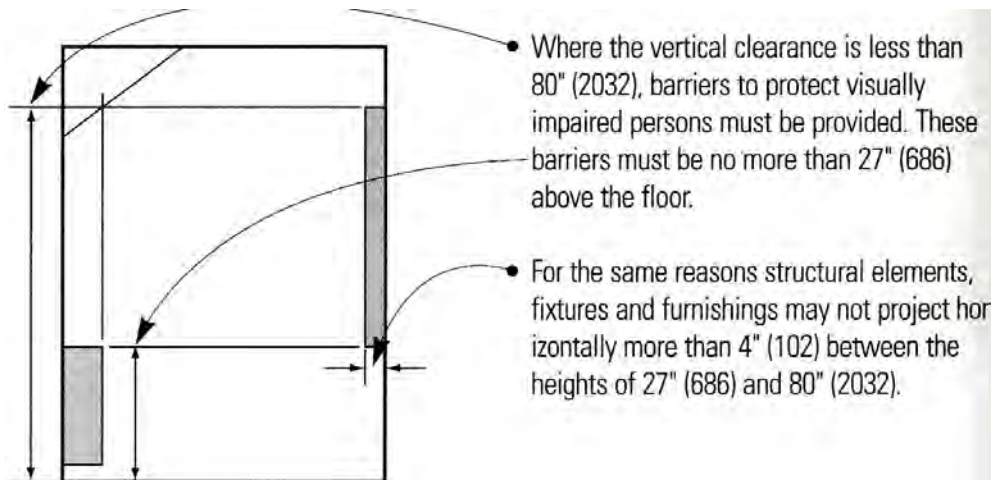
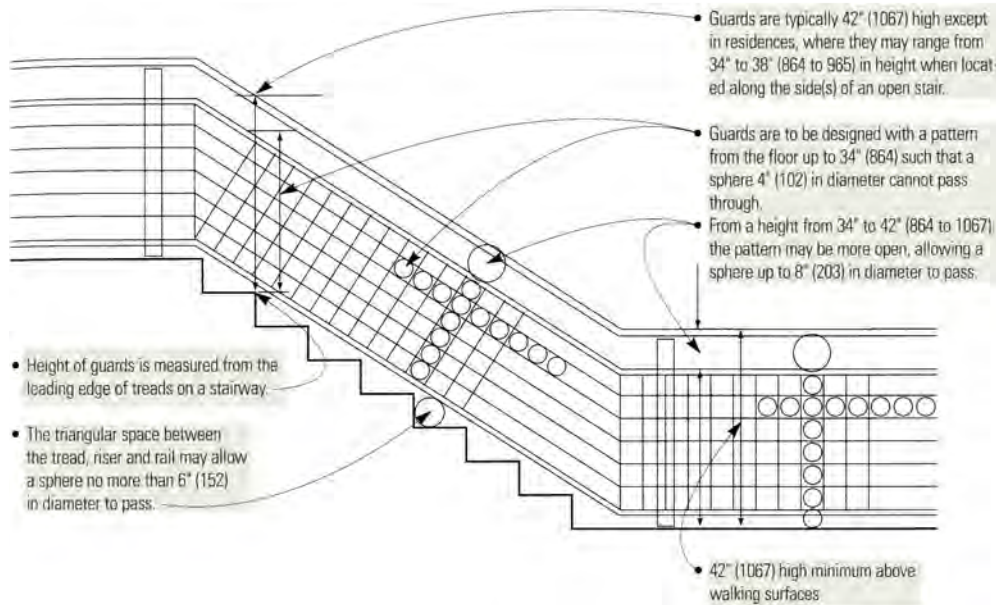

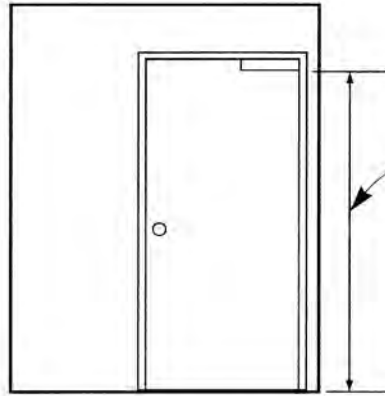

• Door closers and stops may not reduce headroom to less than 78" (1981).

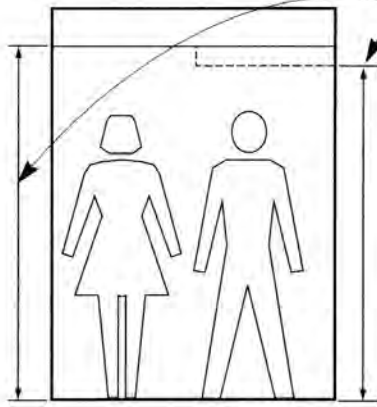

• 7' (2134) minimum ceiling height
• Not more than 50% of the ceiling area of a means of egress may be reduced to 80" (2032) height by protruding objects.

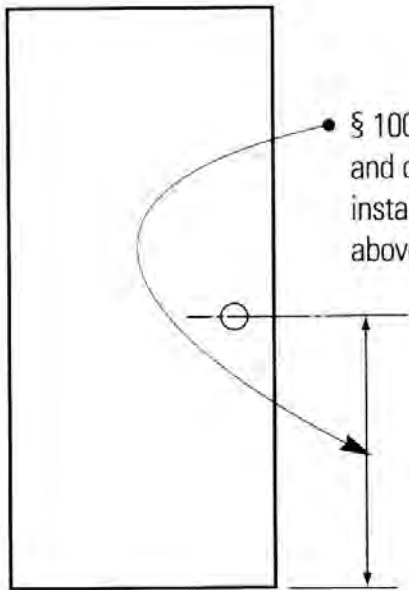

• § 1003.3.1.8.3. Door handles, pulls, locks and other operating hardware are to be installed from 34" to 48" (864 to 1219) above the finished floor.

Handrail Profiles

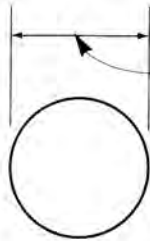

- Handrails are to be graspable, with a minimum radius of 1 1/4" (32) and a maximum diameter of 2" (51).
- Other shapes of equivalent graspability are acceptable. Note that the definition of graspability is subject to interpretation by the building official.

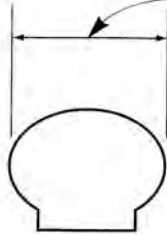

- Railings that do not have a circular profile shall have a perimeter dimension of at least 4" (102) but no greater than 6 1/4" (159) and a maximum cross section dimension of 2 1/4" (57).

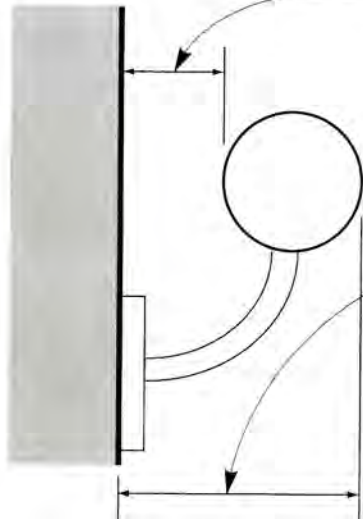

- Handrails require a minimum clearance from the wall of 1 1/2" (38) to allow for grasping.
- There are to be no sharp or abrasive elements to interfere with the ability of the stair user to grasp the handrail. Edges must have a minimum radius of 0.125" (3.2 mm).
- Projections, such as stringers and baseboards, are allowed at each handrail, but they cannot project more than a total of 4 1/2" (114) into the required width of the stairway.

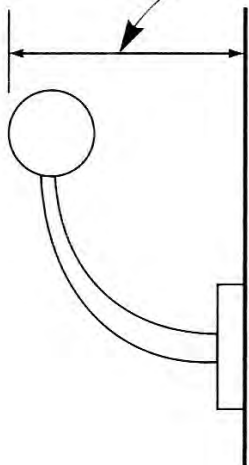

- Stair and ramp handrails may project 4 1/2" (114) from the wall. These requirements are compatible with the accessibility provisions of the Americans with Disabilities Act Access Guidelines (ADAAG).

Handrails

§ 1003.3.11 specifies that stairways are to have handrails on each side except in aisle stairs, where a center rail is provided, or in dwellings. Handrails are not required on decks having a single level change between two areas that are equal to or greater than a landing dimension, and in residences where there is only one riser.

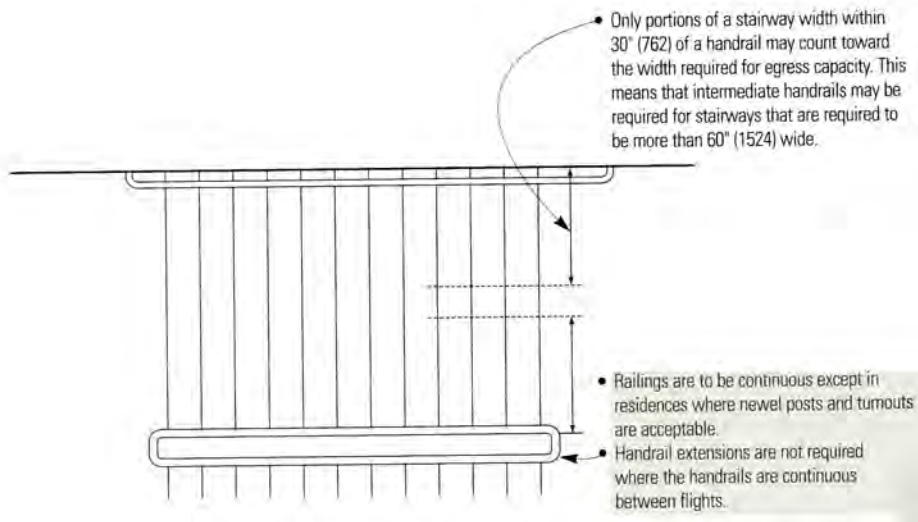
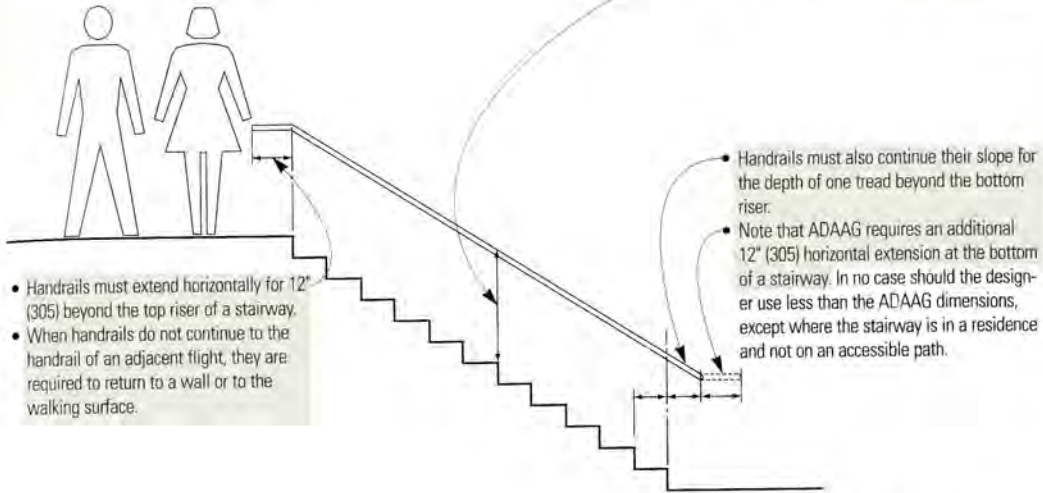

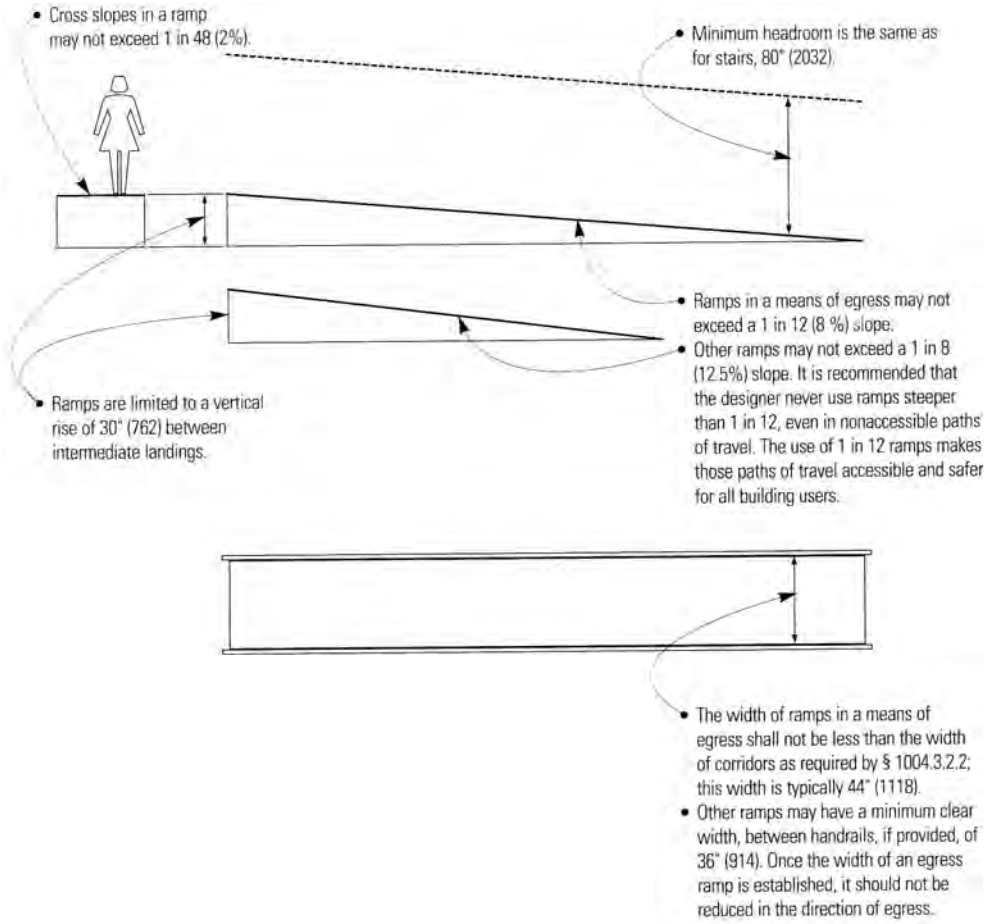

Accessible Means of Egress

For buildings with four or more stories, one accessible means of egress is to be provided by elevator with standby power and signal devices per § 1003.2.13.3. This section seems to reduce the floor elevation threshold for fully sprinklering buildings.

- Because an area of refuge is defined as being a place to await instruction, two-way communications are required between the area of refuge and a central control point, or via a public telephone if the central control is not continuously attended. The communications shall be both visual and audible.

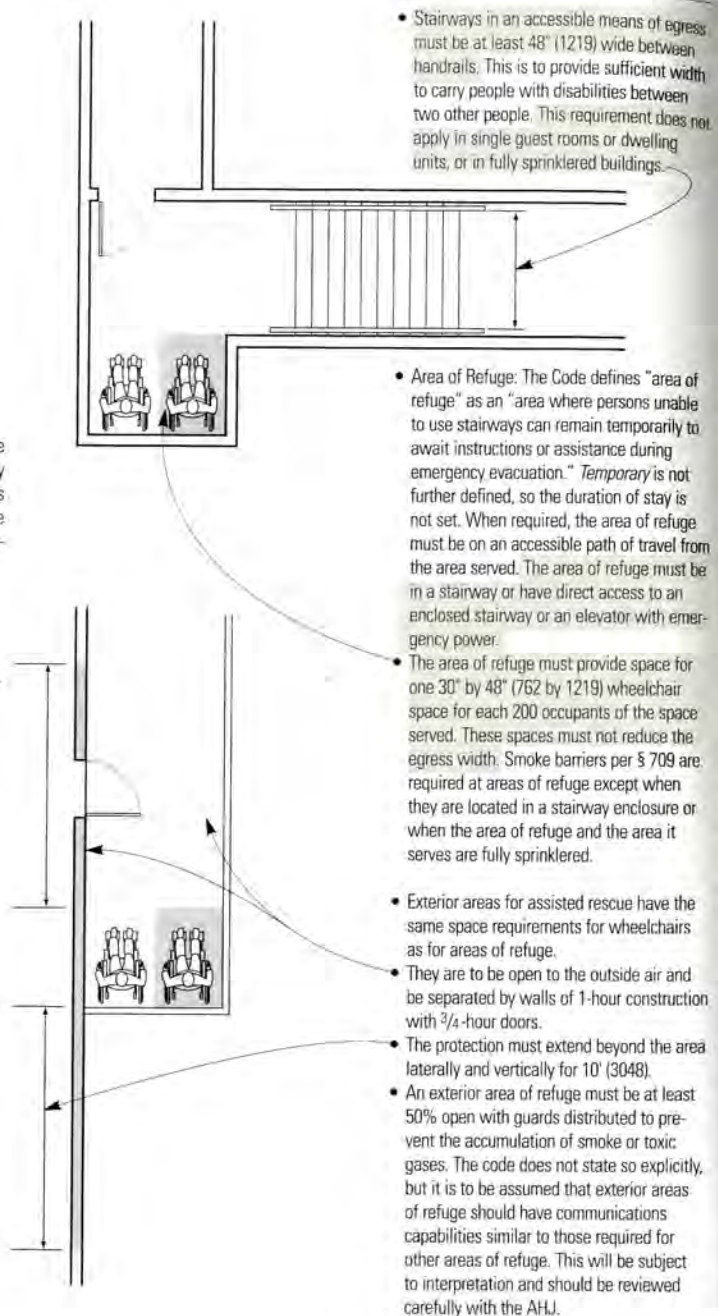

- Stairways in an accessible means of egress must be at least 48" (1219) wide between handrails. This is to provide sufficient width to carry people with disabilities between two other people. This requirement does not apply in single guest rooms or dwelling units, or in fully sprinklered buildings.

- Area of Refuge: The Code defines "area of refuge" as an "area where persons unable to use stairways can remain temporarily to await instructions or assistance during emergency evacuation." Temporary is not further defined, so the duration of stay is not set. When required, the area of refuge must be on an accessible path of travel from the area served. The area of refuge must be in a stairway or have direct access to an enclosed stairway or an elevator with emergency power.

- The area of refuge must provide space for one 30" by 48" (762 by 1219) wheelchair space for each 200 occupants of the space served. These spaces must not reduce the egress width. Smoke barriers per § 709 are required at areas of refuge except when they are located in a stairway enclosure or when the area of refuge and the area it serves are fully sprinklered.

- Exterior areas for assisted rescue have the same space requirements for wheelchairs as for areas of refuge.

- They are to be open to the outside air and be separated by walls of 1-hour construction with 3/4-hour doors.

- The protection must extend beyond the area laterally and vertically for 10' (3048).

- An exterior area of refuge must be at least 50% open with guards distributed to prevent the accumulation of smoke or toxic gases. The code does not state so explicitly, but it is to be assumed that exterior areas of refuge should have communications capabilities similar to those required for other areas of refuge. This will be subject to interpretation and should be reviewed carefully with the AHJ.

ACCESSIBILITY

Residence

Type A units are described in ICC/ANSI A117.1 and are meant to be fully accessible.

Type B units are also described in the standard, but are defined to comply with the technical requirements of the Federal Fair Housing Act Guidelines... Type B dwelling units therefore provide a minimum level of accessibility and are more easily thought of as adaptable units where minor modifications may be made to make them more accessible, if necessary, to accommodate disabled occupants.

1. In walk-up buildings, where no elevator is provided, neither Type A nor Type B dwelling units need be provided on floors other than the ground floor. The number of Type A dwelling units to be provided based on the total of all units in the building, not just at the ground floor. It should be assumed that in buildings with more than 4 and less than 20 units, the ground-floor units should all be Type B units.

2. In podium type buildings without elevators, where the dwelling units occur only above the ground floor, only the dwelling units on the lowest floor need comply with the requirements of this section. Thus on the lowest level of a building with 4 to 20 units, all of the units on the lowest level of dwelling units need be Type B units, but only on that level. When the total dwelling unit count exceeds 20, then Type A dwelling units would need to be provided as required in this section, but again only on the lowest dwelling unit level.

3. A multilevel dwelling unit without an elevator is not required to comply with the requirements for Type B dwelling units. Thus townhouse style multilevel dwelling units are not required to be Type B units. When elevator service is provided to one floor of the unit, however, that floor must meet Type B requirements and a toilet facility provided...

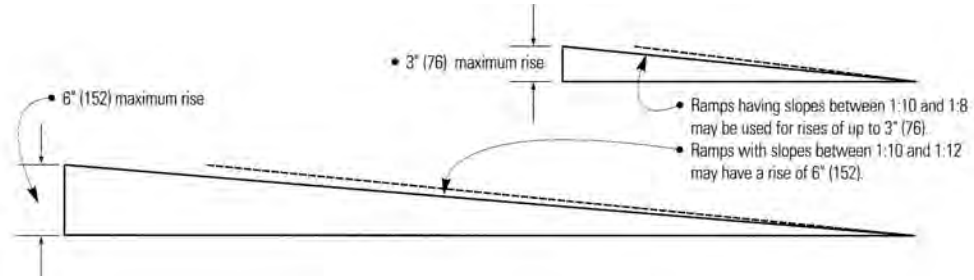

Elevators

IBC § 1108.6 requires passenger elevators on an accessible route to be accessible per ICC/ANSI A117.1.

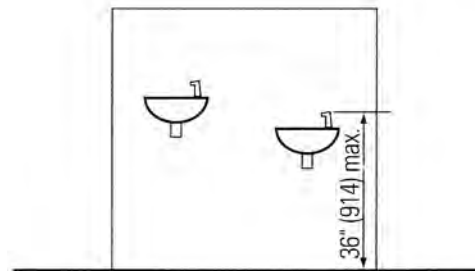
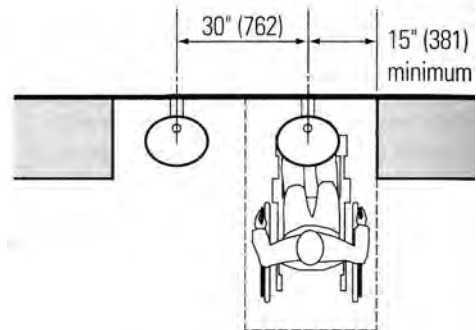
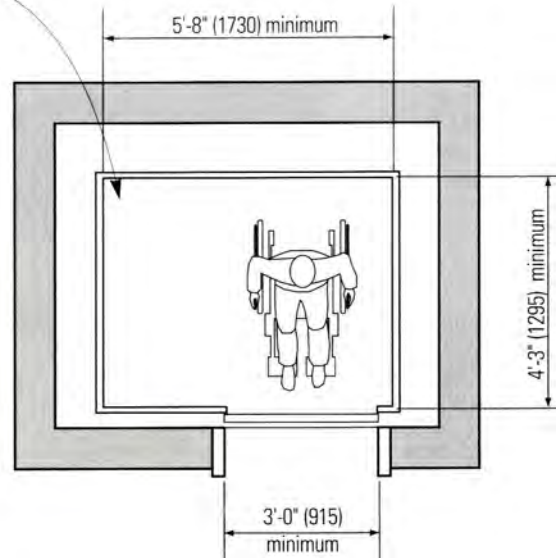

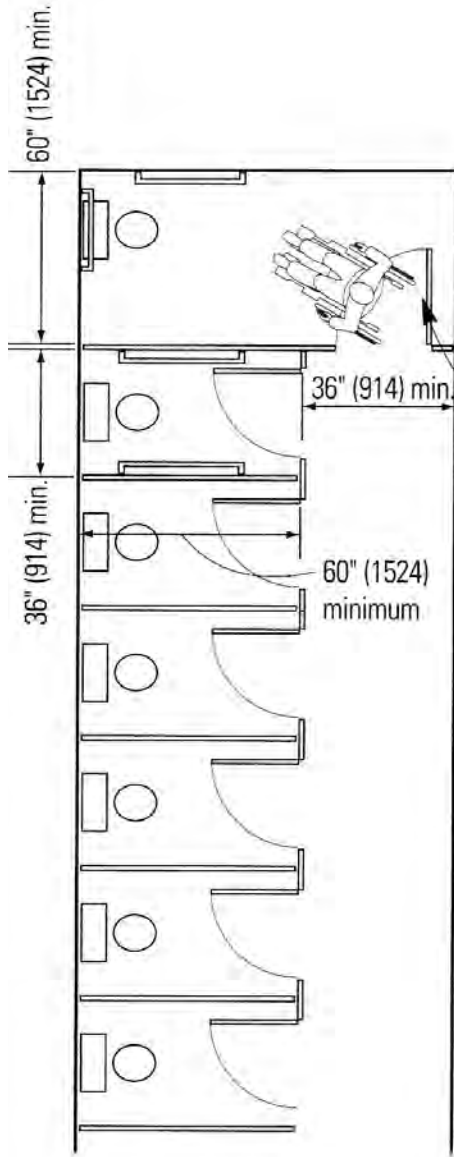

- When water closet compartments are provided, at least one should be accessible.
- When there are six or more toilet compartments in a toilet facility, then at least one compartment is to be an ambulatory-accessible stall per ICC/ANSI A117.1, in addition to the wheelchair-accessible compartment.

BedZed_Zed Factory ltd_Hackbridge, London_2002



Area: 189,147.0683 square feet

82 units: renters and owners

Sustainable systems:

Photovoltaic: 8,363 sf

Passive ventilation: wind cowls

Passive solar

Thermal Mass

Rainwater harvesting

Energy-use metering and monitors per resident

Roof Gardens: habitat and storm-water retention

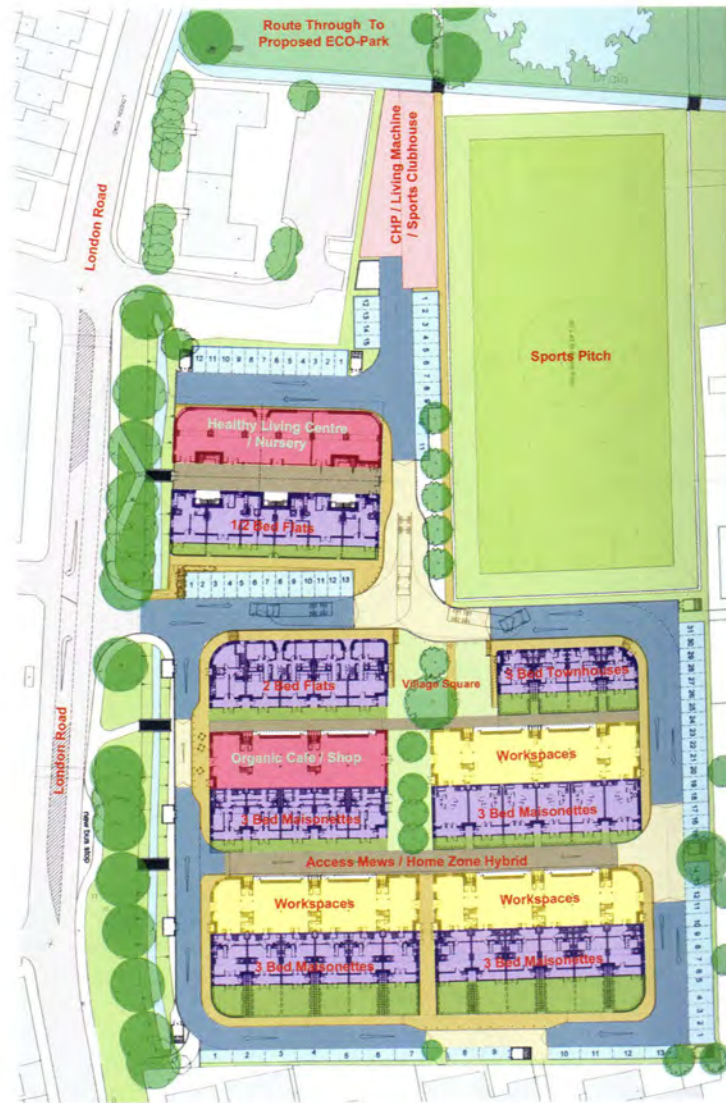

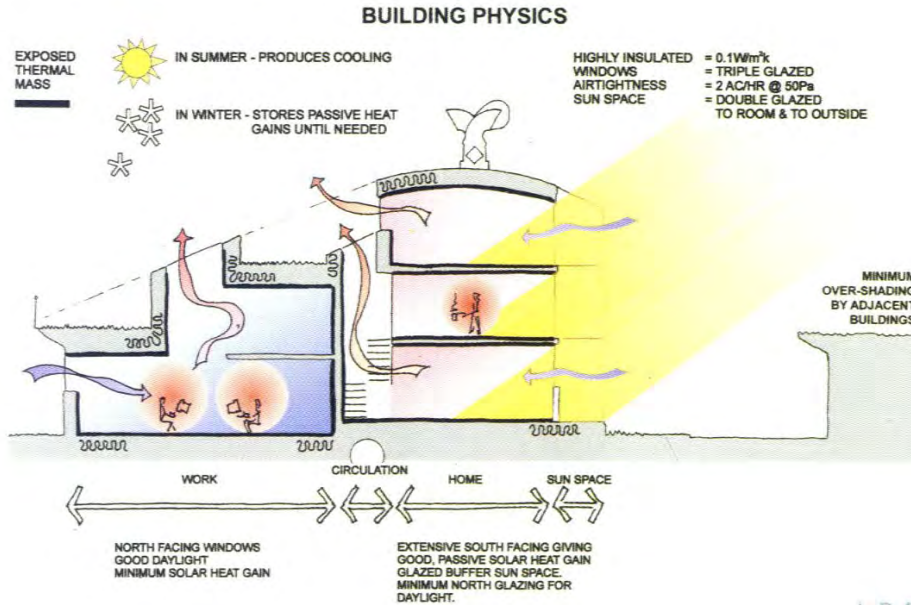

“We have placed gardens on the workspace roofs—which allows virtually every home to have a garden, showing how density can be increased at the same time as increasing amenity.” [“Bill” 82]

At the same time as providing most new homes with both a garden, a south facing conservatory, and the opportunity to avoid commuting by working on site. [“Bill” 82]

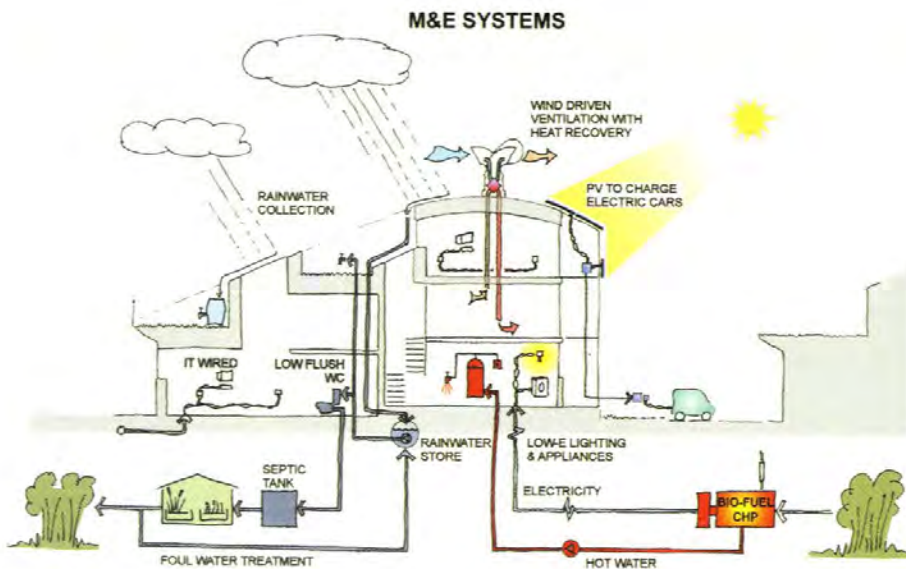



Built to densities that mean we could meet almost all the three million or so new homes required by 2016 on existing stocks of brownfield sites—without losing valuable agricultural land and green belt to low density traditional development. [“Bill” 82]

“Environmentally benign innovation will cost more, so we have enabled the developer to buy a site with outline planning permission for a housing estate with a maximum permitted density, and then add on office park without having to pay for land.” [“Bill” 82]



“So at BedZED we have tried to make it so easy and convenient to lead a near carbon neutral lifestyle that most people simply default into this way of living without conscious effort .”[“Bill” 82]

“If ZED standards became commonplace most of our habitat could be carbon neutral well before the start of the next century.”[“Bill” 82]

Linked Hybrid_Steven Holl_Beijing, China_2003-2009



PROGRAM:
728 apartments
public green space
commercial zones
hotel
cinema
kindergarten
Montessori school
underground parking

Pedestrian Oriented

Follows principles of feng-shui

Aims at LEED Gold

“An ultra-modern expression of 21st Century ecological urban living.” [“Steven” 228]



promotes interactive relations and encourages encounters in the public spaces that vary from commercial, residential, and educational to recreational. three-dimensional urban space in which buildings on the ground, under the ground and over the ground are fused together

Genzyme Center_Behnick Architekten_Cambridge, Massachusetts_2003



Area: 350,000 square feet

Central atrium:

Light

Connection with indoor gardens

Communication with colleagues

Control over the environment:

Temperature

Lighting

Ventilation

Vegetated roof

Recycled construction materials

Water efficient technology

Areas for:

Team interaction

Informal conversation

Formal presentations

“The ground floor of Genzyme Center is public space—some of it to be occupied by retail shops—which invites the public in and connects Genzyme with its neighbors.” [Genzyme]

“Genzyme Center serves as a cornerstone of a ten-acre development that will include a performing arts center, residences, a hotel, office and laboratory space, retail shops, and a park.” [Genzyme]

“stands as a highly visible expression of some of the core values that have driven the company’s success—innovation, transparency, collaboration” [Genzyme]





“Genzyme Center’s design enhances communication by encouraging informal meetings in the building’s common spaces, garden areas, and in the top-floor cafeteria with its sweeping views of the Boston cityscape.

Various terraces, corners and walkways are furnished to encourage spontaneous conversations.

Offices are kept small, while the amount of common space per employee is substantially greater than the average U.S. office building.

Transparent office walls invite colleagues in.

These features foster a higher level of interaction, collaboration, and creativity.”
[Genzyme]

Most offices and workspaces have direct views outside. “Eighteen gardens located throughout the building help bring the outdoors in.” [Genzyme]



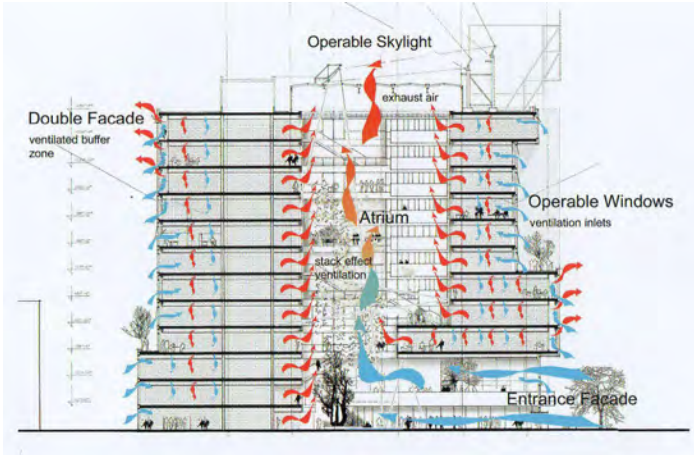

Heliostats track the sun-light and reflect it into an atrium.

The light is then dispersed by a reflective chandelier and reflective pool.

“Materials used in the building such as carpets and paints meet or exceed the highest standards for the emission of volatile organic compounds...”

Fresh air is introduced into the building in part through 800 operable exterior windows.

Air flows to the atrium and is released through exhaust fans near the skylight.” [Genzyme]

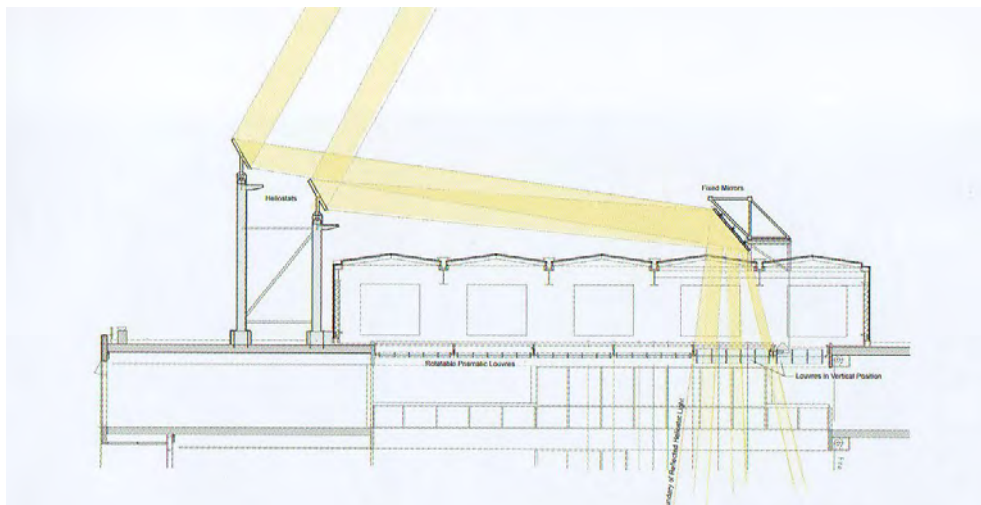
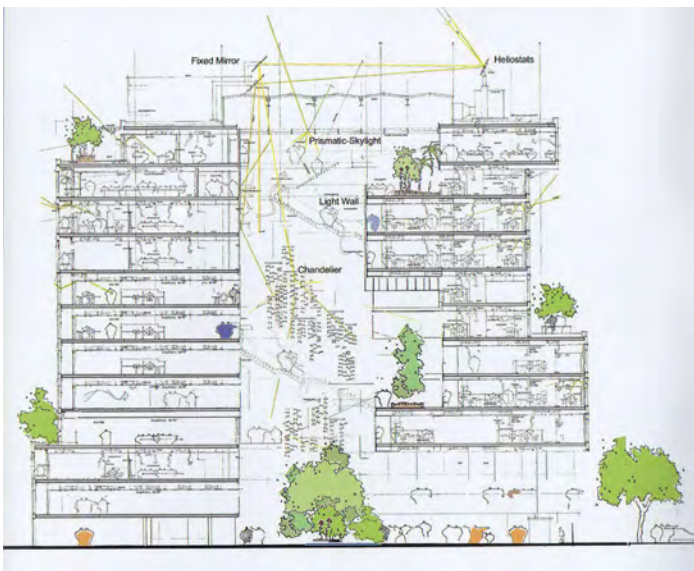

Ward Residence_ Marmol Radziner and Associates_ Pacific Palicades,
California_

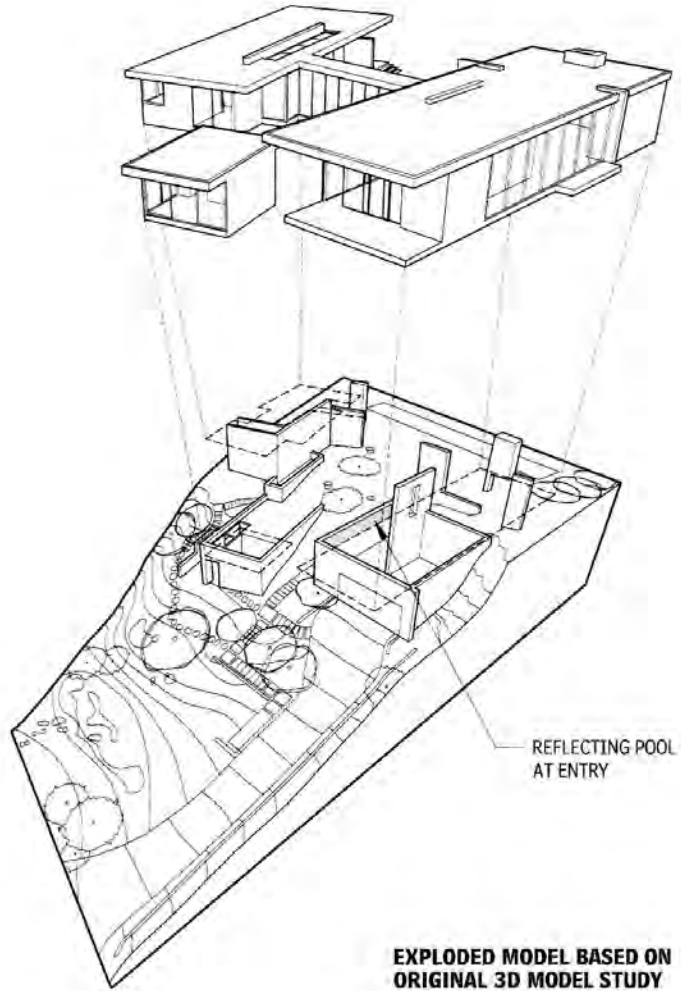



© Benny Chan and Marmol Radziner

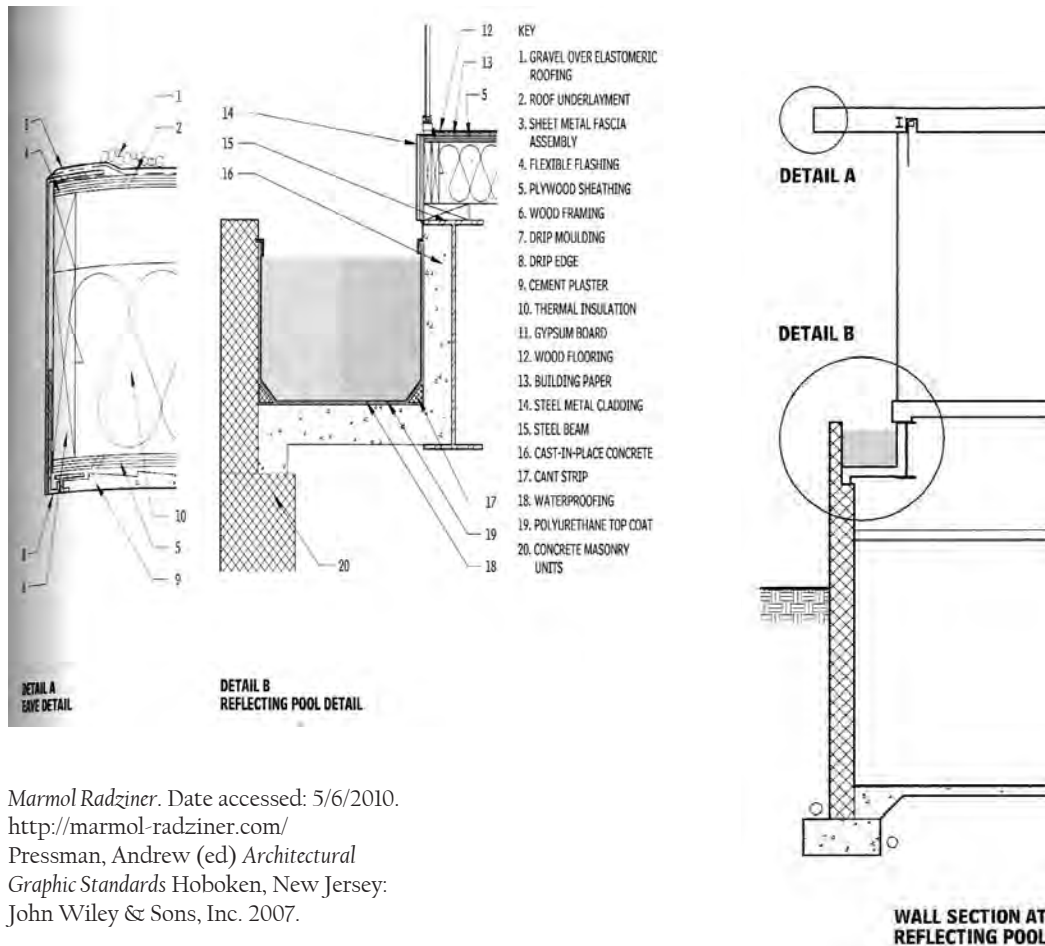

Marmol Radziner. Date accessed: 5/6/2010.
<http://marmol-radziner.com/>
 Pressman, Andrew (ed) *Architectural Graphic Standards* Hoboken, New Jersey: John Wiley & Sons, Inc. 2007.

State Gallery and Chamber Theatre_ James Stirling_ Stuttgart, Germany_1977-83



Point of Interest: Pedestrian Walk

“A **public footpath connects** the hillside areas of Stuttgart to the city centre, passing through the museum, round the rotunda, and down to an ample terrace with a car park under. The gallery entrance is located here, where a ramp and steps descend to a taxi drop-off point on the busy main road. The **pedestrian walk** continues along the terrace past a cafeteria, and under an archway where the building projects forward to give a **sense of enclosure** to the terrace and to **mark** the Chamber Theatre.” [Wilford 55]

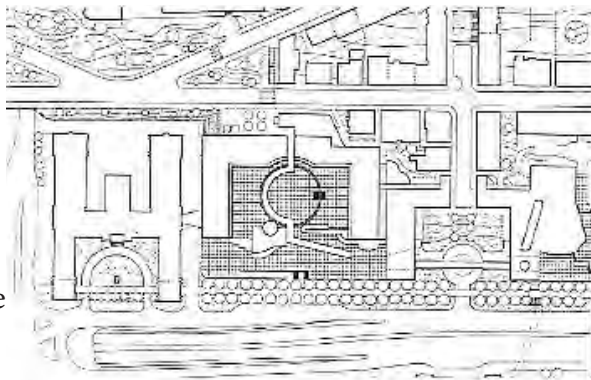



Rotunda and public walkway



Steps up to sculpture terraces

Anica Landreneau “Introduction to Sustainable Design” *Lecture at Roger Williams University School of Architecture, Art and Historic Preservation 9/10/2009.*

This slide show lecture provides an overview on the LEED system criteria and provides reasons for its implementation.

Bhatt, Vikram & Kongshaug, Rune. “Coalesce of beauty and utility for better cities.” *XXII World Congress of Architecture (UIA)*, Istanbul, July 3-8, 2005.

This article presents an argument for urban agriculture. It covers the history of city life in relationship to gardens and agriculture and a case study of community gardens in Montreal. Cities have in the past been closely tied to agriculture. Bringing agriculture back into urban areas can be beneficial to the community.

Bhatt, Vikram. “Project Background.” *Making the Edible Landscape: A Study of Urban Agriculture in Montreal*. Montreal Qc: Minimum cost Housing Group, 2005.

This text provides background information on the importance of urban agriculture. It postulates the reintroduction of agriculture into urban areas, for example, through green roofs. Several examples of this technique that are currently in effect are cited. Contributions of this technique are brought to light, as well as concerns to be considered in the development of urban agriculture. The social benefits of urban agriculture are also considered.

“Bill Dunster architects: BedZed Beddington Zero Fossil Energy Development, Beddington, Sutton, UK 1999-2001”. *A+U: Architecture and Urbanism* August 2004 n. 8 (407) p.[80]-86

This source contains photos, diagrams, plans, site plan, and computer drawings of the precedent BedZed.

Boehland, Jessica “Gish Family Apartments” *Green Source The McGraw-Hill Companies, Inc* 2010 date accessed: 4/27/2010 http://greensource.construction.com/projects/2009/01_GishFamilyApartments.asp

This website contains information on the Precedent Gish Apartments by OJK.

Campos, Cristian, *Plastic Design* Koln: Daab 2007.

This book contains images and text on the precedent Genzyme Center.

“Downtown Eau Claire” *Eau Claire* Eau Claire Area Economic Development Corporation: 2010, Date accessed: 4/17/2010. http://images.google.com/imgres?imgurl=http://www.eauclaire-wi.com/images/map_downtownec.jpg&imgrefurl=http://www.eauclaire-wi.com/market_info/market_stat/ecDowntown.php&usg=__LdO8IsSDo-cZNoIsb5bDbzHE-Xs=&h=373&w=380&sz=20&hl=en&start=22&um=1&itbs=1&tbnid=MfVIbuPSvnElOM:&tbnh=121&tbnw=123&prev=/images%3Fq%3Dnorth%2Bbarstow%2Bredevelopment%2Beau%2Bclaire%2Bwi%26start%3D21%26um%3D1%26hl%3Den%26sa%3DN%26rls%3Dcom.microsoft:en-us%26ndsp%3D21%26tbs%3Disch:1

This source provides a map of downtown as well as relevant information such as major attractions of Eau Claire.

Ching, Francis D.K. & Winkel, Steven R. *Building Codes Illustrated* Hoboken, NJ: John Wiley & Sons, Inc. 2003.

This book contains information on the International Building Code (IBC) covering the following topics: Building Codes, Navigating the Code, Use and Occupancy, Special Uses and Occupancies, Building Heights and Areas, Types of Construction, Fire-Protection Systems, Means of Egress, Accessibility, Interior Environment, energy Efficiency, Exterior Walls, Roof Assemblies, Structural Provisions, Building Materials and Systems, and Existing Structures. It includes text and diagrams.

“City of Eau Claire Sustainable Development Zoning Codes” 8/21/2009. date accessed: 1/3/2010 <http://www.ci.eau-claire.wi.us/community/green-page>

This website contains information on the implementation of sustainability in Eau Claire, Wisconsin. (2 pages)

“City of Eau Claire Comprehensive Plan Sustainability Chapter” 8/21/2009. date accessed: 1/3/2010 <http://www.ci.eau-claire.wi.us/community/green-page>

This website contains information on the implementation of sustainability in Eau Claire, Wisconsin. (35 pages)

“City of Eau Claire’s Comprehensive Plan Sustainable Development Policies”
8/21/2009. date accessed: 1/3/2010 <http://www.ci.eau-claire.wi.us/community/green-page>

This website contains information on the implementation of sustainability in Eau Claire, Wisconsin. (15 pages)

Dunnett, Nigel & Noël Kingsbury. *Planting Green Roofs and Living Walls*. Portland, Or.: Timber Press, 2004.

This source provides information on green roofs and living walls. It includes detailed explanations as to why and how they are beneficial as well as case studies. Information on how to construct and green roof is included. Although it focuses on extensive rather than intensive green roofs, information on intensive green roofs is also included.

“Eau Claire, Wisconsin” Avadameg, Inc: 2003-2010. Date accessed: 4/17/2010. <http://www.city-data.com/city/Eau-Claire-Wisconsin.html>

This website contains demographic information on Eau Claire, Wisconsin.

Genzyme Center Genzyme Corporation 2005.

This brochure contains information on the precedent Genzyme Center by Behnisch & Partner. It contains text on both the building and the company, photographs, diagrams, plans, and sections.

“Gish Family Apartments” *AIA/COTE Top Ten Projects*, date accessed: 2/22/2010, American Institute of Architects, 4/13/2010.

This website contains a brief overview of the Gish Apartments. It includes a brief description of the project’s environmental aspects, a brief program, and an exterior photograph.

Guterson, Mary “Living Machines: Putting human waste back in its place: at the bottom of the food chain” *In Context*

This article discusses the use and functional characteristics of Living Machines. It uses the Boyne River school as a precedent and quotes John Todd.

<http://www.freebirdhouseplans.net/>

This website includes information on how to build birdhouses for specific bird species and how to find the appropriate location for them.

IdeX Washington State University. Date accessed: 4/17/2010;5/14/2010. <http://www.idexstudio.org/>

This website contains information on innovative sustainable systems such as a “wall machine.” A wall machine is a living machine scaled to be integrated into the design of a single toilet to treat the waste water.

“Indoor Air Quality Concerns” *The Inside Story: A Guide to Indoor Air Quality*. U.S. Environmental Protection Agency. Last Updated: Monday, March 22, 2010 Date accessed: 3/23/2010. <http://www.epa.gov/iaq/pubs/insidest.html#Intro>

“Other research indicates that people spend approximately 90 percent of their time indoors.”

Marmol Radziner. Date accessed: 5/6/2010. <http://marmol-radziner.com/>

This website is the homepage of the architect Marmol Radziner who designed the precedent Ward Residence.

“North Barstow Area Redevelopment: Architectural Design Guidelines” February 2005. Date accessed: 4/17/2010. <http://www.eauclairedvelopment.com/docs/Architectural%20Design%20Guidelines.pdf>

This source details the design guidelines set forth for the redevelopment of the North Barstow area.

“North Barstow Redevelopment Area”, *City of Eau Claire, 1872-2009*. date accessed: 4/17/2010. <http://www.ci.eau-claire.wi.us/city-manager-home/971-north-barstow-redevelopment-area>

This source provides information on community interest in the redevelopment, including specific areas and goals of interest.

Keeler, Marian & Burke, Bill, *Fundamentals of Integrated Design for Sustainable Building*, Hoboken, NJ: John Wiley & Sons, 2009

This book contains information on integrated design.

It covers chemicals, air quality technologies, energy, resources, materials, water, waste, rating systems, and case studies.

“Linked Hybrid”, date accessed: 2/22/2010, www.stevenholl.com/project-detail.php?id=58

This website contains information on the precedent Linked Hybrid by Steven Holl. It includes photographs, diagrams, a google site plan, a description of the project, and brief reviews from journals and newspapers.

“Native Plants and Seeds” *Prairie Nursery 2010* www.prairienursery.com

This online catalogue contains listings of native prairie plants. It is also a growing guide.

Ockman, Joan. “City and Landscape” Victor Gruen . *Architecture Culture 1943-1968*. New York, NY: Rizzoli International Publications, Inc. 1993. pp.194-199.

This text contains the architectural theories of Victor Gruen. Gruen states that the world has been shaped into city and landscape, the former being further broken into four categories: technoscape, transportationscape, suburbcape, and subcityscape. Architecture, according to Gruen, should not be concerned with a single building but “all man-made elements which form our environments, with roads and highways, with signs and posters, with outdoor spaces as created by structures, with cityscape and landscape.” (194) Gruen admirably calls for a more integrated form of design that creates vital, healthy environments that support one another and which bring landscape back into our surroundings.

Pallasmaa, Juhani. “Hapacity and Time” in *Architecture Review* May 2000 pp. 78-84.

This article links all the senses to the sense of touch and discusses the negative impact that the dominance of the visual impact of design has had on architecture. Further, it discusses the issue of time and the fact that change is inevitable, constantly occurring, and can be beautiful if taken into consideration in design.

Pressman, Andrew (ed) *Architectural Graphic Standards* Hoboken, New Jersey: John Wiley & Sons, Inc. 2007.

This text contains construction details as well as precedent information, such as the Ward Residence by Marmol Radziner.

Staples, Sarah. "Edible Landscape Project turns Slums into Gardens." *Urban Agriculture Notes*. Can West News Service, October 25, 2004. Date accessed: 7/8/2009. <http://www.cityfarmer.org/edible.html>.

This text discusses Vikram Batt's plant to reform slums through the planting of gardens. The philosophy behind this is that "trees and greenery in a city should serve to keep people alive." (1) It is even suggested that crime rates can be lowered through agriculture. Urban agriculture in slums could provide food and income for the group that most needs it.

Steen, Sten, Bainbridge, Eisenberg *The Straw Bale House* White River Junction, Vermont: Chelsea Green Publishing Company 1994.

This text contains photographs, drawing details, and diagrams on straw bale construction.

"Steven Holl" *El Croquis* v. 141 2008.

This text contains information on the precedent Linked Hybrid by Steven Holl. It includes text, diagrams, photographs, plans, sections, elevations, etc.

Stirling, James & Wilford, Michael. *Buildings and Projects 1975-1992* Thames and Hudson 1994.

This book contains information on the precedent State Gallery and Chamber Theatre in Stuttgart, Germany. This was recommended to me as a precedent during the first review.

"Title 24:Housing and Urban Development" *US Laws*. Date accessed: 5/6/2010. <http://law.justia.com/us/cfr/title24/24-5.1.3.1.1.4.13.5.html>

This website contains information on structural design requirements. It includes information on wind and snow load zones.

Todd, John A *Living Machine for Teaching Ecology*

This article discusses Living Machines and uses the Boyne River School as a precedent.

Utah State Office of Education “Cycles” *Utah Education Network* Date accessed: 3/30/2011 <http://www.uen.org/themepark/cycles/nature.shtml>

This Website contains information on the cycles of nature. Information can be found in Technical Research_Nature’s Cycles

White, Stephen. *Building in the Garden: the Architecture of Joseph Allen Stein in India and California*. Oxford & New York: Oxford University Press, 1993.

This text not only contains the works of Joseph Stein but his concepts and theories as well. Further, those architects who had an influence on Stein are incorporated into the text where relevant. Stein advocates a sustainable future, one that puts architecture in touch with the environment while retaining a desire to meet human needs.

“Wisconsin Wind Data” *Wisconsin State Climatology Office* last revised: 7/20/2009. date accessed: 9/27/2010. <http://www.aos.wisc.edu/~sco/clim-history/stations/eau/eclwind.html>

This website contains information on wind patterns in Wisconsin.

Yeang, Ken. *Designing With Nature: The Ecological Basis for Architectural Design*. New York: McGraw-Hill, Inc, 1995.

This book discusses significance and strategy of ecological design. Humans and our built environment are part of an ecosystem, a closed-loop unit. Design should be concerned not only with the physical elements of a site, such as climate, but with the organic and biological elements, such as plant and animal communities. Ecology is a system of interactions, rather than a single environment.