

1980

The Malaysian Fishing Gears and Methods

Mohamed Ibrahim Bin Haji Mohamed
University of Rhode Island

Follow this and additional works at: http://digitalcommons.uri.edu/ma_etds

 Part of the [Aquaculture and Fisheries Commons](#), and the [Oceanography and Atmospheric Sciences and Meteorology Commons](#)

Recommended Citation

Bin Haji Mohamed, Mohamed Ibrahim, "The Malaysian Fishing Gears and Methods" (1980). *Theses and Major Papers*. Paper 21.

This Major Paper is brought to you for free and open access by the Marine Affairs at DigitalCommons@URI. It has been accepted for inclusion in Theses and Major Papers by an authorized administrator of DigitalCommons@URI. For more information, please contact digitalcommons@etal.uri.edu.

THE MALAYSIAN FISHING GEARS AND METHODS

by

MOHAMED IBRAHIM BIN HAJI MOHAMED

A MAJOR PAPER SUBMITTED IN PARTIAL FULFILLMENT OF THE
REQUIREMENTS FOR THE DEGREE OF
MASTER OF MARINE AFFAIRS

UNIVERSITY OF RHODE ISLAND

1980

PREFACE

The Malaysian Fishing Gears and Methods

There are more than 40 types of fishing gears operated in Malaysia. These gears are classified locally into 11 gear groups based on their principles of operation.

These gears have never been fully documented. In most instances, information on certain fishing gears can only be found by obtaining it from the operators, who may or may not be fully conversant with all the technical specifications of the net. This lack of basic information hampers the development efforts by Government and other National and International agencies in their attempts to improve the fishery.

This investigation attempts to document all the commercially important fishing gears in the country, the technical specifications, methods of operation, identify special differences in gears, operation and review the share/lay system operated in the industry.

The use and development of fishing gears evolve in different parts of the country primarily through uncoordinated efforts. Effective new methods of fishing are introduced into an area by fishermen through trial and error and experience. For instance, fishing nets are built by methods brought down as family traditions. Introduction of new

proven design are therefore very difficult. Thus present gears operated are those used by their forefathers with little or no changes except in dimensions as a result of introduction of engine power. This trial and error method of technology transfer is expensive and time-consuming.

Another result of uncoordinated development is the wide range of terminology used. Similar terms used in different parts of the country mean different things while different terms used may mean similar things. These features tend to retard efforts to improve fishing technology.

All these facts point towards the importance of a document to codify the various gears and their operation. Certainly, the first step towards technological improvement is to take an inventory of what is available and operated at the present time.

Codification of the Malaysian fishing gears will benefit a cross-section of the people involved in fisheries, including gear technologists, fishery development officers, economists, extension officers, international agencies involved with fishery development, teachers and fishery students.

It is hoped that this paper will contribute in a small way towards alleviating the lack of information concerning the Malaysian fishing gears.

ACKNOWLEDGEMENTS

I am indebted to Dr. Niels West, faculty advisor; the faculty members of the Department of Geography and Marine Affairs, University of Rhode Island; the faculty of Fisheries and Marine Sciences University Pertanian Malaysia for the financial support, and its many students who assisted in the surveys; Division of Fisheries, Ministry of Agriculture, Malaysia and Fisheries Development Authority, Malaysia, for arranging placements for the survey; and finally, the numerous fishermen without whose cooperation and generosity this document would not have been possible.

CONTENTS

PREFACE.	ii
ACKNOWLEDGEMENTS	iv
CONTENTS	v
LIST OF ILLUSTRATIONS.	viii
LIST OF PLANS.	ix
CHAPTER	
1 INTRODUCTION: THE MALAYSIAN FISHERY.	1
The fishery catch	
Catch by major gear groups	
Catch by area	
The fishing fleet	
Role of fishery	
Fishing vessels	
The effect of tide on fishing operation	
II CLASSIFICATION OF MALAYSIAN FISHING GEARS	10
III TRAWLING	12
Principle	
Trawl net	
Operation	
Species caught	
Trawling and the Fisheries Act	
Lay/Share system for trawlers	
IV SEINING	23
Purse seining	
Purse seine vessel	
Purse seines	
Complement of the vessel	
Operations	
Seining (Pukat Kenka)	
Principles	
Seine nets	
Operation	
V GILL NETS/DRIFT NETS	46
The net	
Operation	
Lay system	
Trammel nets	

	PAGE
VI LIFT NETS.	57
The net	
Operation	
Fish detection method	
VII TRAPS.	63
Principles	
Red fish pot	
Operation	
Share system	
Fishing stake	
Dimensions of the fishing stake	
Net	
Operation	
Processing	
Share system	
Jermal	
Construction	
Net	
Operation	
Share system	
VIII HOOK AND LINE.	77
Principles	
Hand lines	
Commercial operations	
The Gear	
Operation	
Long lines	
The Gear	
Operation	
Share system	
IX BAG NETS	85
Principles	
The net	
Operation	
Share system	
X PUSH NETS	90
The net	
Operation	
XI BARRIER NETS.	93
Principles	
The Net	
Operation	
Catch	

CONTENTS

	PAGE
XII SHELLFISH COLLECTION.	97
Catching implement Operation	
XIII MISCELLANEOUS GEARS	100
Squid jigging Cast net Crab liftnet Scoop net for shrimp Hooks for crabs	
XIV FUTURE DEVELOPMENT OF MALAYSIAN FISHING . .	105
Gears Improvement in fishing gear Fishing gear material Fishing gear design Selectivity of fishing gears Fishing methods	
REFERENCES	114

ILLUSTRATIONS

FIGURE		PAGE
1.0	Malaysia - Exclusive Economic Zone.	4
1.1	Profile of West Coast Fishing Vessel.	7
1.2	Profile of East Coast Fishing Vessel.	7
3.0	Deck Arrangement of Trawler Ready for Shooting.	18
3.1	The Towing Operation.	18
3.2	Hauling the Cod End Aboard.	19
4.0	Deck Arrangement of a Purse Seiner.	25
4.1	Purse Seining Operation	34
4.2	Transfer of Fish from Anchored to Mobile Lure Lines - Shooting the Gear.	37
4.3	Light Buoy.	37
4.4	Shooting the Seine Net.	44
4.5	Towing the Seine Net.	44
5.0	Shooting the Net.	48
5.1	A Gill Net Set in the Water	48
5.2	The Threadfin Gill Net Set.	50
5.3	Hauling the Net	50
6.0	Setting the Lift Net.	60
6.1	Handling the Catch.	60
7.0	The Redfish Pot	66
7.1	Setting the Traps	66
7.2	The Fishing Stake- Kelong.	70
7.3	The Jermal.	74
7.4	Flat Net for the Jermal	74
8.1	Some Common Handline Construction	78
8.2	Mackerel Handline	80
8.3	Lures for Mackerel Handline	80
9.0	The Bag Net (Gombang) Set	87
10.0	The Push Net.	92
10.1	The Push Net Operation.	92
11.0	The Barrier Net Set	94
12.0	The Cockle Rake	98
12.1	Dredging Operation.	98
13.0	Miscellaneous Gear.	104

FISHING GEAR PLANS

PLAN		PAGE
3.1	Fish trawl.	13
3.2	Shrimp trawl.	14
4.1	Mackerel purse seine.	27
4.2	Anchovy purse seine	28
4.3	Seine net	42
5.1	Threadfin gill net.	53
5.2	Spanish mackerel/wolf herring gill net. . .	54
5.3	Threadfin gill net (Senohong)	55
5.4	Trammel net	56
6.0	Lift net	62
7.0	Fishing stake net	69
7.1	The Jermal.	76
8.0	The Longline set.	82
9.0	The Bagnet (gombang).	89
11.0	The Barrier Net	96

CHAPTER 1

1.0. Introduction: The Malaysian Fishery

Peninsula Malaysia with a coastline of about 1200 miles long supports a relatively small but significant fishery. In the last two decades the annual marine fish landing has exhibited an increasing trend. Primary reasons for this increasing trend are: a) the mechanization of the fishing fleet; b) the introduction of trawling in 1965; and c) the government's commitment to develop the fishery.

1.1. The Fishery Catch

In 1978, the total fishery catch in Peninsula Malaysia was 564,898 metric tons (Annual Fishery Statistics 1978). This is an increase of 66,946 m.tons or 13.4% over the 1977 catch. Whereas the increase in catch in 1977 was 21.2% over the previous year, this year's increase indicates a slower rate of growth. On the average, the total catch has been increasing at a rate of 4.5% annually for the past decade.

1.2. Catch by Major Gear Groups

The Malaysian fishery is characterized by a large number of species. Jones (1976) suggested that the number of commercially important species is more than 300. Besides being a multispecies fishery, it is also a multigear fishery.

Fishing gear employed range from traditional traps, simple scoop nets, beach seines, and fishing stakes, to the more modern gears such as trawling and purse seining. The relative importance of these different fishing gears are illustrated in Table I representing catch by gear group for 1978.

Gear Groups	Catch in Metric Tons	% of Total Catch
Trawls	285,019	50.4
Seines	127,200	22.5
Shellfish collection	56,098	9.9
Gill nets/drift nets	31,508	5.6
Bag nets	26,916	4.8
Hook and Line	15,186	2.7
Lift net	10,410	1.9
) Fish pots	4,494	.8
Traps) Fishing stakes	4,363	.8
Push nets	963	-
Barrier nets	641	-
Miscellaneous	2,000	.4

Table I. Marine Fish Landing by Gear Groups

Source: Annual Fishery Statistics 1978, Ministry of Agriculture Malaysia.

Trawling accounts for some 50% of the total catch. Prior to the introduction of trawling in 1965 the two most important fishing gears in terms of catch were seining and fishing stakes. Shellfish collection has become the third most important year only since 1973. This is the result of cockle culture which proliferated after that year.

Corresponding to the amount of fish caught by the major gear groups, the total number of fishing gears licensed is 25,924 units. Gill nets represent the largest group

with a population of 12,794 units, trawls second with 4504, seine nets with 2615 units. This is followed by bag nets with 1784 units, 1264 shellfish collection units, 1214 units of hook and line, and the others below 1000 units each.

1.3. Catch by Area

Figure I.0 shows the position of Malaysia in relation to its neighbors, fishing areas and the extent of its exclusive economic zone. In Peninsula Malaysia, the fishing can be divided into east and west coast fishery. As a general rule the west coast lands 70% of the total catch while the east coast makes up the other 30%. This higher catch ratio in the west coast is attributable to the higher level of capital investment, mechanization and the number of fishing vessels in the west coast. West coast fishery has 72% of the nation's fishing fleet.

In 1978, the east coast contribution to the total catch rose to 37.5%. This is a result of increasing fishing activity in the east coast and the government's actions to develop the relatively underexploited east coast stocks.

1.4. The Fishing Fleet

There are 27,497 vessels in the Malaysian fishing fleet. Eighty-four percent of the vessels are below 15 gross tons, 16% between 15-25 gross tons and the remaining

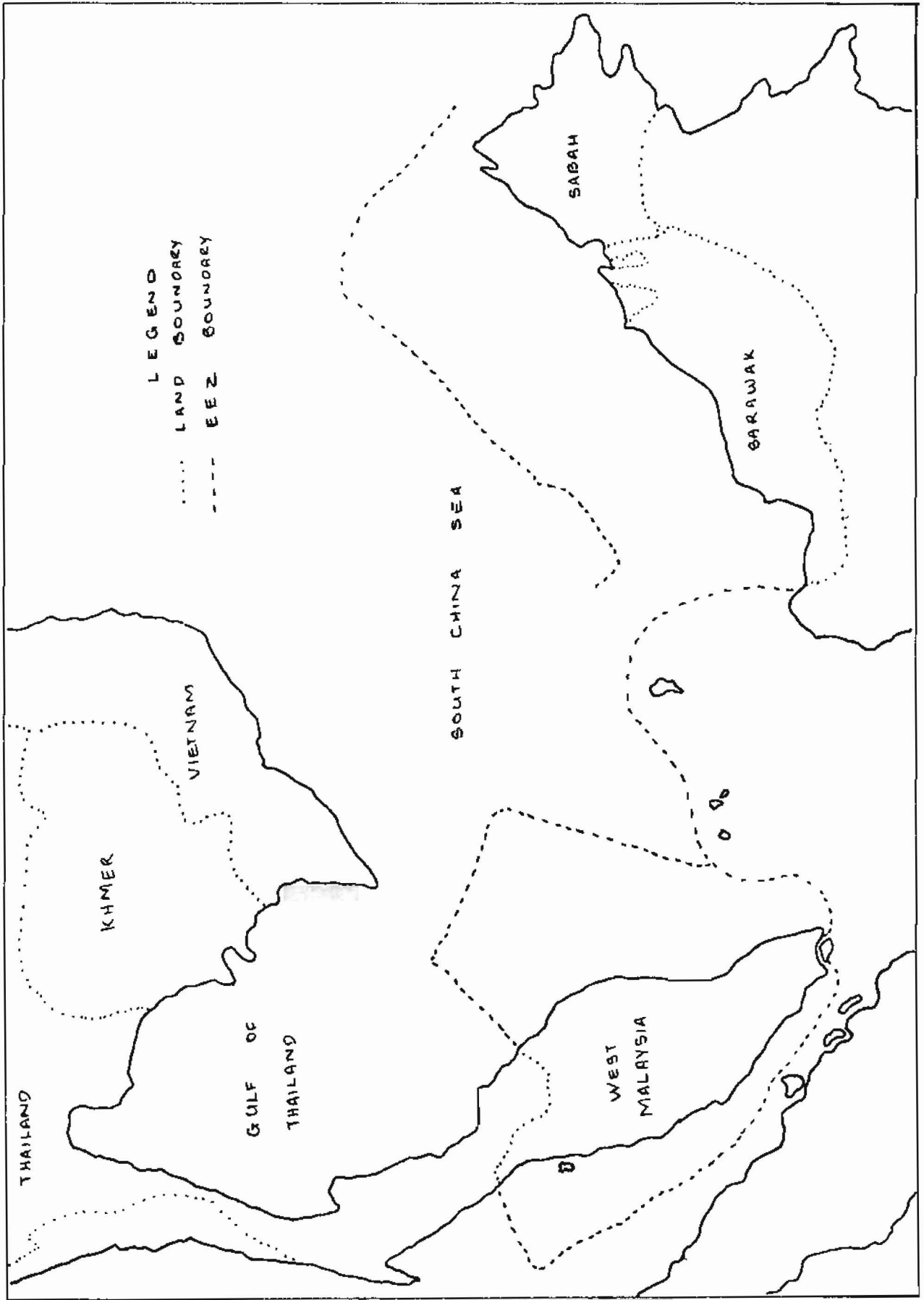

NOT TO SCALE

FIG 1.0 MALAYSIA - EXCLUSIVE ECONOMIC ZONE

SOURCE: PROCEEDINGS WORKSHOP ON DEMERSAL RESOURCES OF THE SUNDA SHELF (3.10.77 - 4.11.77)

10% between 26 and 100 gross tons. While 64.6% of the fleet are powered by inboard engines, some 13.4% are outboard powered, and the other 22% nonpowered.

The fishery is primarily inshore in nature with 90% of the operation carried out within 50 miles from the shore. Offshore fishing activities include fish traps and tuna long-lining, the latter operated as a joint venture with Japanese firms.

1.5. Role of Fishery

Fisheries play an important role in the Malaysian economy. It provides a much needed source of cheap (relative to meat and poultry) animal protein to the populace. It generates direct employment to some 83,000 fishermen mostly from the rural areas dotting the coastline and it earns foreign exchange.

The fishery sector contributes about 3 percent to the gross domestic product and absorbs almost 4% of the economically active labor force. Rice and fish constitute a staple diet of Malaysians. The per capita consumption of fish in Malaysia averaged about 62 lbs. (28 Kgs) in 1974.

1.6. Fishing Vessels

Two types of design are predominant in Malaysia. Amazingly, regardless of the type of operation the vessel is engaged in, its design is practically similar. This is

the result of traditional boat building methods whereby the skilled boat builders are only familiar with one type of design and are reluctant to change. Whereas sizes may differ, the shape and construction methods are strikingly similar. Recently more current design of vessels has been added to the fleet.

In the west coast the fishing vessels are characterized by V-shaped hulls, only a slight shear, and little or no flare in the bow. Wheelhouse is located aft with a forward working deck. Figure I.1 following illustrates the general shape of west coast vessels.

In the east coast another set of characteristics predominate. Basically, the hull is more rounded, a more pronounced shear is exhibited, and with a flare at the bow. The wheelhouse is situated either amidships or forward with the working deck aft. Figure I.2 illustrates the general shape of the east coast vessel.

The evolution of design and shape of these vessels is prompted by the different weather conditions prevailing on the two coasts. In the west coast where fishing is done in the Straits of Malacca and vicinity, the waters are sheltered, consequently, vessels are more open, with little need for such features as shear and flare. In the east coast, however, the more severe conditions and open seas are reflected in the design and construction of the vessels by having more closed areas, a sheltered working deck, a

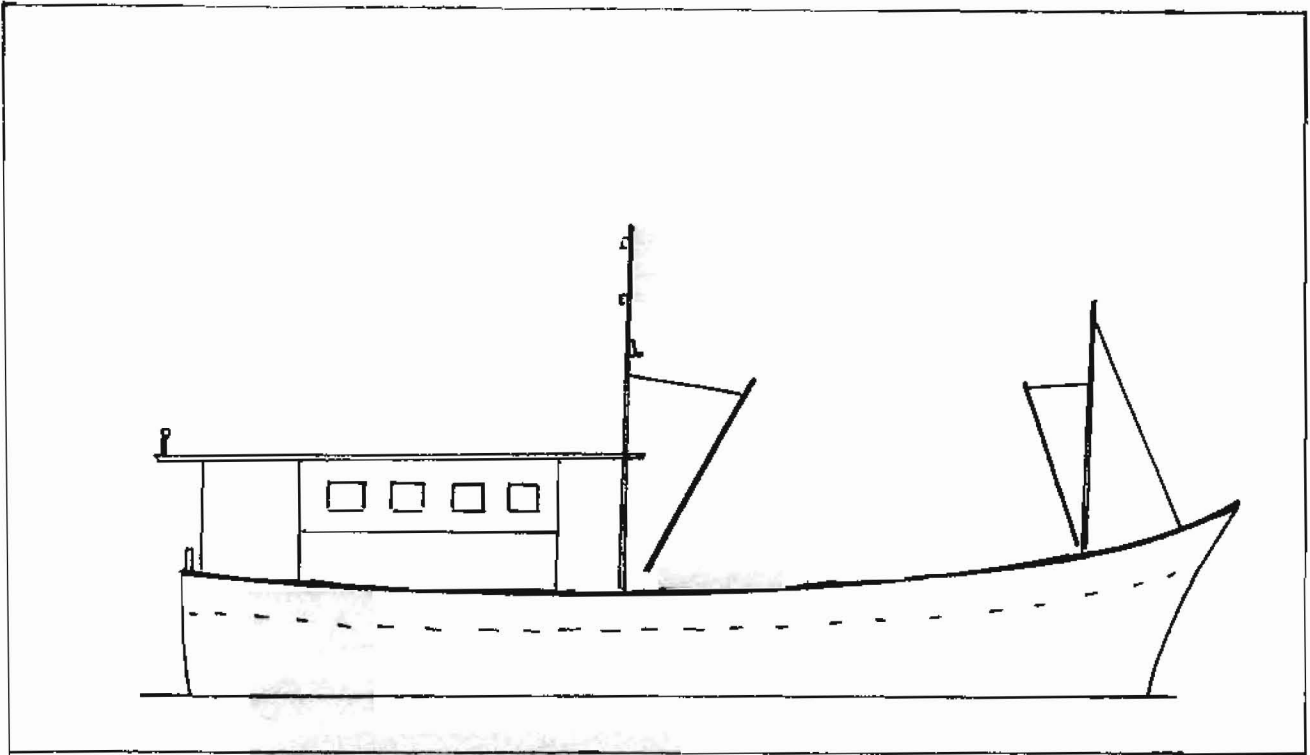

FIG 1-1 PROFILE OF WEST COAST FISHING VESSEL

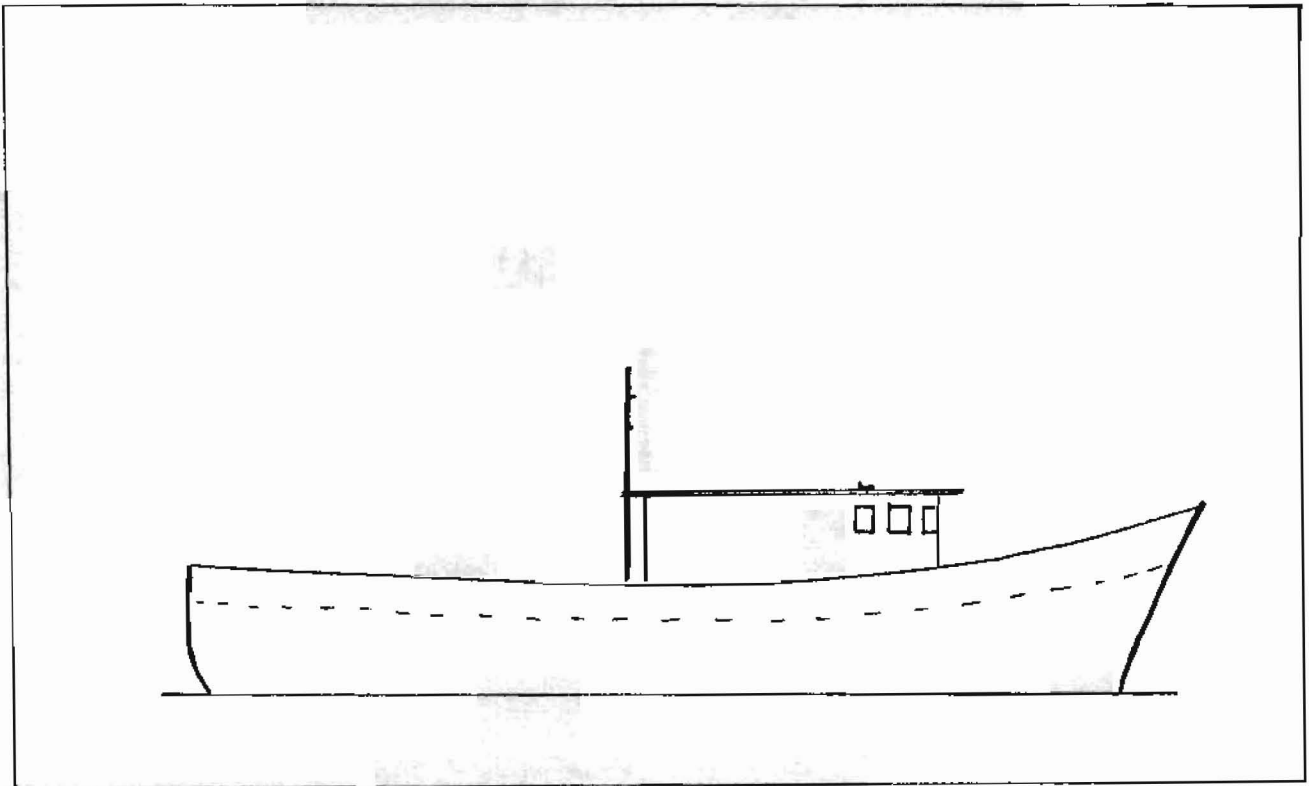

FIG 1-2 PROFILE OF EAST COAST FISHING VESSEL

more pronounced shear, higher freeboard and a flare at the bow to guard against pounding and to minimize shipping of water aboard.

Where differences end, similarity begins. Fishing vessels are normally constructed of wood. There are no formal galley accommodations or toilet facilities. Although these vessels are good sea boats, there is hardly any life-saving apparatus or fire-fighting equipment carried on board.

Navigational equipment normally consists of a magnetic compass. Except for the latest vessels no marine communication equipment is carried aboard. The prevailing trend of thought within the industry is to keep cost as low as possible. This, together with the mode of operating being day or short trips, it is not surprising that little or no equipment is carried on board except the essentials.

1.7. Effect of Tide on Fishing Operation

Most of the fishing operation in Malaysia is affected by tidal oscillation. For instance, stationary gears that filter the water require areas of large tidal differences to operate effectively. Floating gill nets require tides to carry them over large areas. Seining operations are more effective when assisted by strong tides. Consequently, spring tides are important fishing times while neap tides are poor fishing periods. On the lunar calendar 7th to 12th day and 22nd to the 27th day are periods of neaptides

while spring tides are from the 12th to 22nd and 27th to the 7th day of the months.

CHAPTER II

2.0. Classification of the Malaysian Fishing Gears

Fishing gears are classified in many ways. Von Brandt (1964) classified fishing gears into 16 classes. Sainsbury (1971) classified commercial gears into 4 main classifications; namely towed or dragged, encircling, static and other mobile gears.

Malaysian fishing gears are classified into 11 gear groups based upon the principles and operation of the gears. Table II illustrates the various groups and several examples representing each group. This list is by no means exhaustive but it represents most of the commercially important gears.

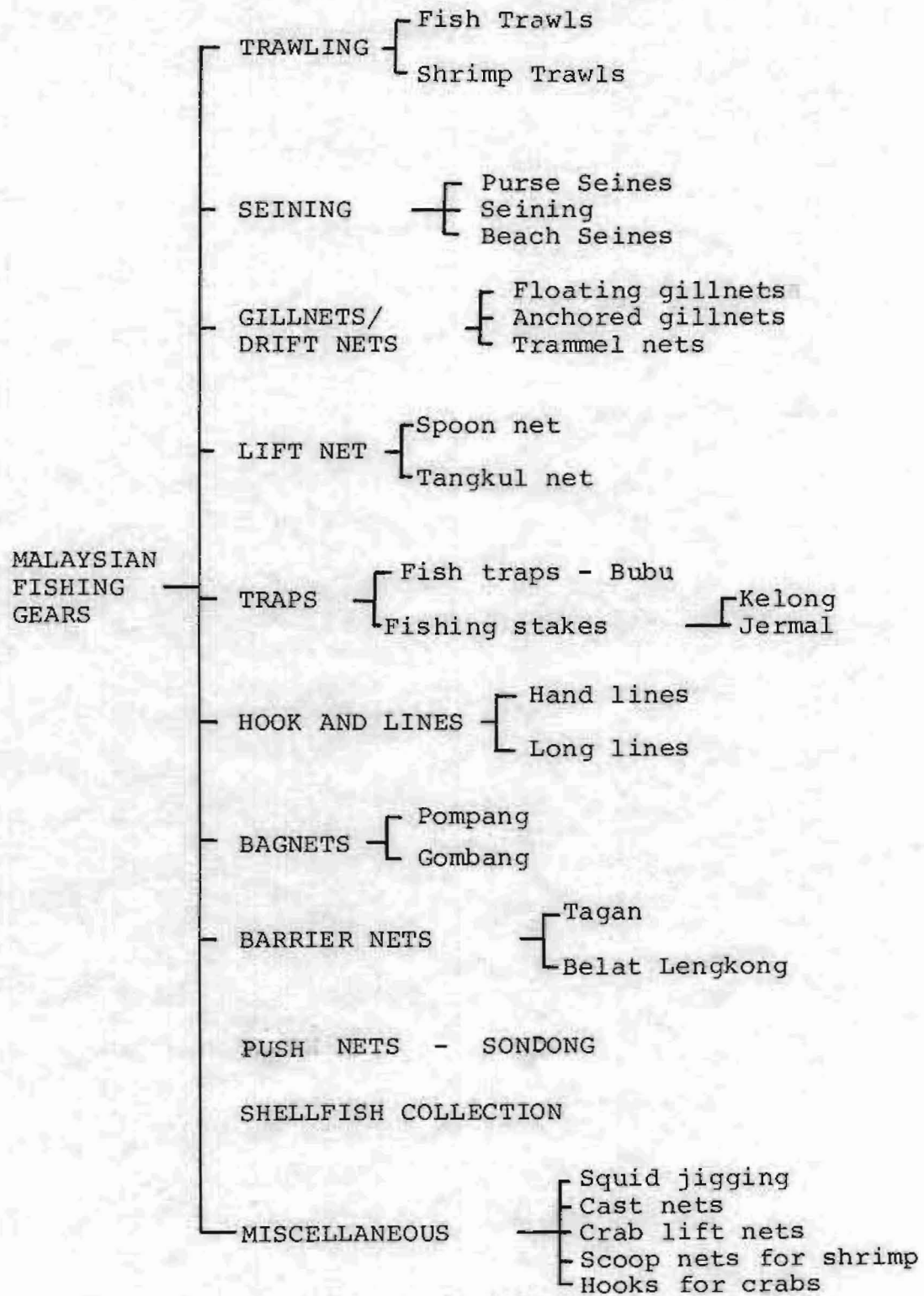

TABLE II. CLASSIFICATION OF THE MALAYSIAN FISHING GEARS

CHAPTER III

3.0. Trawling

Since first introduced in the mid-1965 from Thailand, trawling has become the most important class of fishing gear used in the Malaysian fishery. It is one of the most widely used gear throughout Peninsula Malaysia. Generally regarded as the most effective fishing gear it also accounts for almost all the illegal fishing¹ in the country.

3.1. Principle

The principle of trawling is to tow a conically shaped net through the water. This net is large at the mouth and tapers to the rear into a bag called a cod end. The mesh size of the netting gets progressively smaller from the mouth towards the cod end to ensure retention of the catch. The net may be towed on the seabed or the midwater column and is hauled aboard at suitable time intervals to empty the catch.

3.2. Trawl Net

There are basically two types of trawls operated in the fishery; fish and shrimp trawl. Plan 3.1 and 3.2

¹Fishing without a license or not in accordance with the terms and conditions of a license.

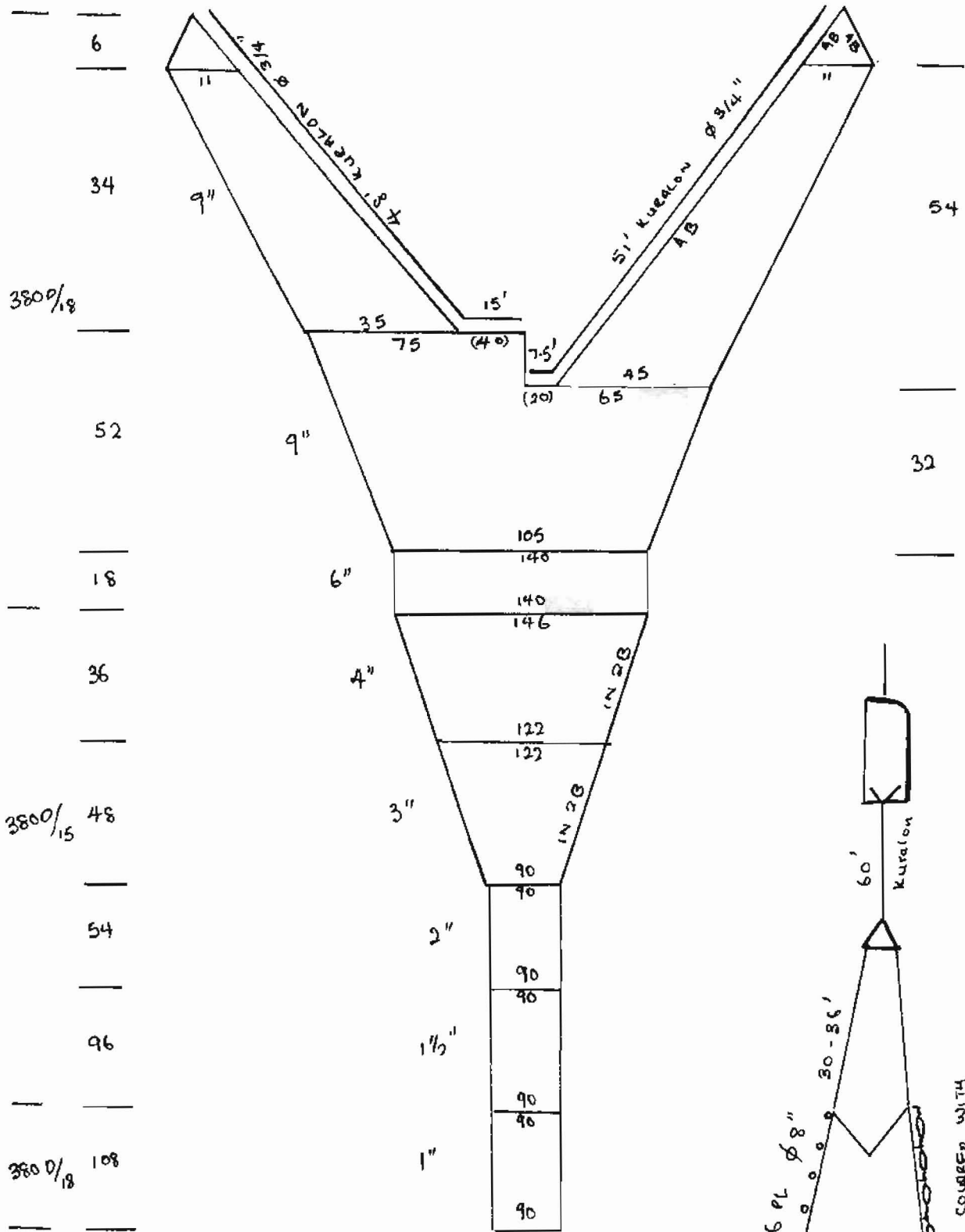

PLAN 3-1 FISH TRAWL.

PLAN 3-2 SHRIMP TRAWL

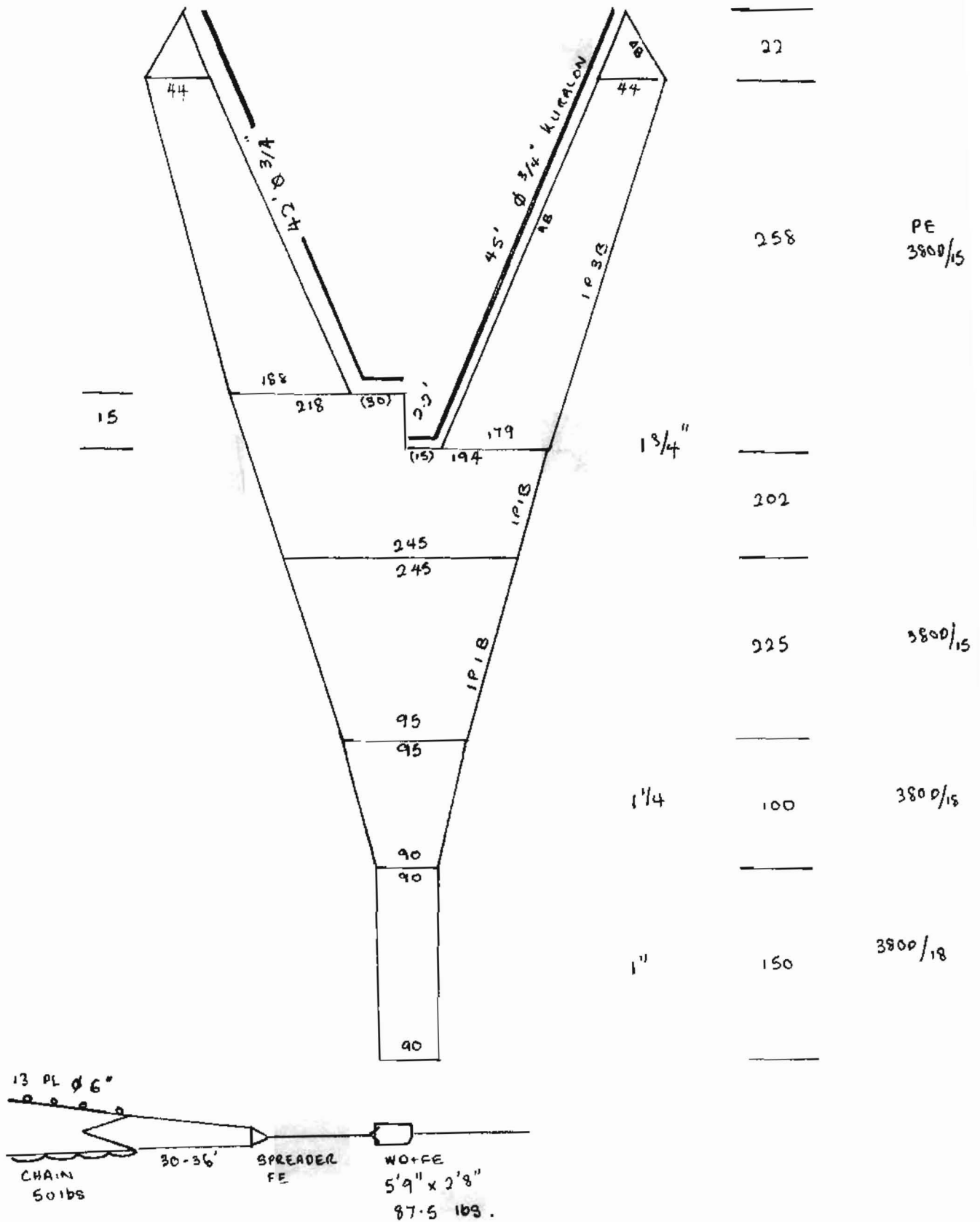

illustrate the trawls, respectively. In terms of design the two trawls are similar. The fish trawl are larger and longer. Mesh sizes range from 9 inches in the wings to 1 inch at the cod end.

Shrimp trawls are smaller in size and are made of small meshes. Wings are made of 1-3/4 inch progressively getting smaller to 1 inch or even 3/4 inch at the cod end.

The headrope and foot rope are made of hard lay Kuraton in one piece. There is a disadvantage to this type of construction as any break in the headrope or footrope will mean having to change the whole piece. Present gear built for larger vessels have combination steel wire headrope and are built in three pieces, i.e. two wing pieces and one bosom piece. For the older trawls a break in the rope can be spliced together overcoming the disadvantage mentioned earlier.

The netting material used is polyethylene and a cover of heavier twine envelops the cod end. This cod end cover is normally made of mesh sizes similar to the cod end.

3.4. Operation

All trawling operation in Malaysia is conducted by the stern. It is interesting to note however that due to the design of the vessel and lack of mechanization, the fishing operation is quite unique.

The net is laid at the stern of the vessel. The doors are attached to the bridles and the towing warps prepared

Two towing booms are attached to the side of the wheelhouse and lashed to the gunwale. The towing warp is slotted in a recess at the end of the boom. The rest of the towing warp is coiled properly on both sides of the wheelhouse ready for shooting. This ready position is illustrated in Figure 3.0.

A simple sound signal is used by the skipper operating the gear to indicate to the helmsman the speed of the vessel. These signals are given below.

<u>Signal</u>	<u>Vessel movement</u>
1 short blast	free the engine
2 short blasts	slow ahead
3 short blasts	astern
4 short blasts	full ahead

On the signal from the skipper the net is first shot with the vessel going slowly ahead. Once the net is in the water, a couple of turns are taken around the towing post. The vessel then picks up speed to spread the net.

Once the net is fully open the otterboards are shot followed by the towing warps. The vessel picks up speed to pay the the free-flowing trawl warps. When most of the warps are paid out the vessel slows down to avoid the sudden tension on the warps. Towing then commences. The shooting operation takes approximately 10-15 minutes.

The towing time varies from 2-4 hours depending on the concentration of fish, species aimed for and the nature of the fishing ground. These decisions are made by the

skipper who has full knowledge of the grounds. Figure 3.1 shows the position of the warps during the towing operation.

Hauling:

The vessel is slowed down, towing warp collected and put through the towing blocks at the side of the wheelhouse. Hauling is done by the use of two warping heads at the side of the wheelhouse. The warps are coiled on deck ready for the next shooting.

Once the otterboard is taken aboard a couple of turns are taken around the towing post. The vessel increases speed to raise the net and wash the catch into the cod end. Once the net surfaces, the vessel is stopped or goes astern carefully to assist the manual hauling of the net to the cod end.

The cod end is then taken forward of the wheelhouse. The catch is then taken aboard by the use of a block as shown in Figure 3.2. After emptying the catch the cod end is tied and reshot for the next tow. Four to six tows are carried out in one day's operation after which the vessel returns to port to discharge its catch.

Shrimp trawling operation is performed in the same manner as fish trawling described above.

3.5. Species Caught

It is not uncommon to find 20-30 species of fish in one trawl. This includes shads, flatfish, groupers, red snappers, snappers, barracudas, pomfrets and numerous other

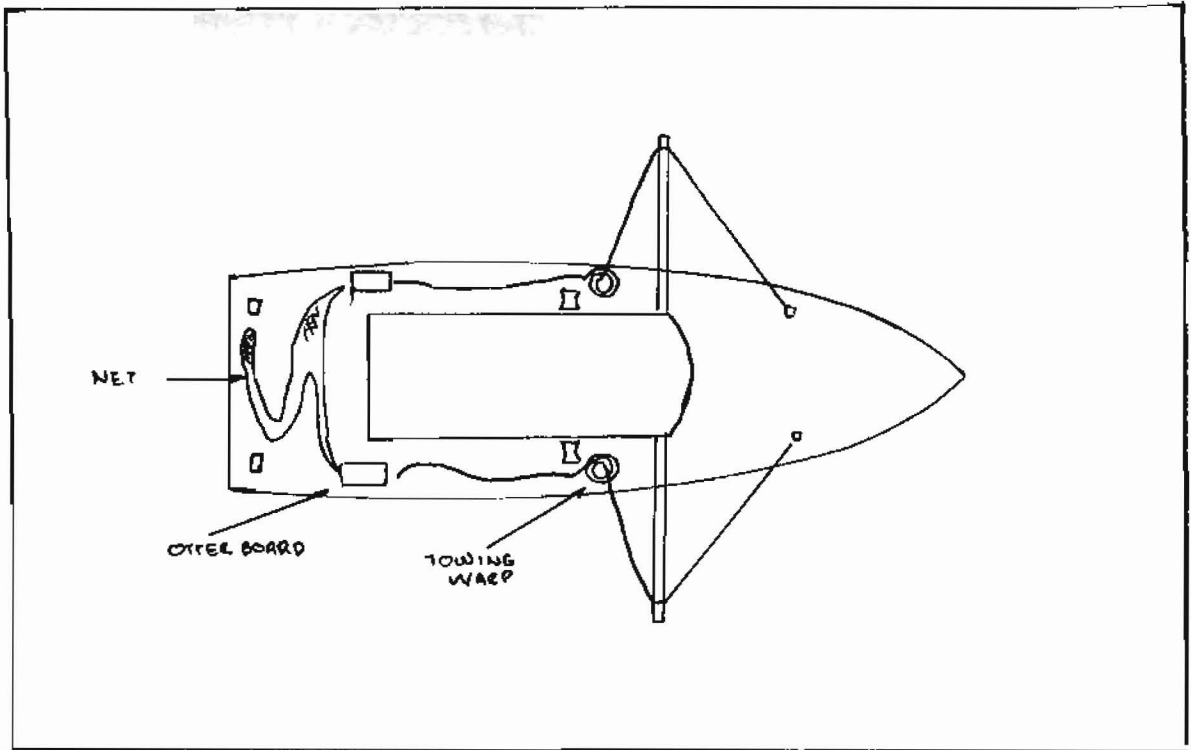

FIG. 3.0 DECK ARRANGEMENT OF TRAWLER READY FOR SHOOTING

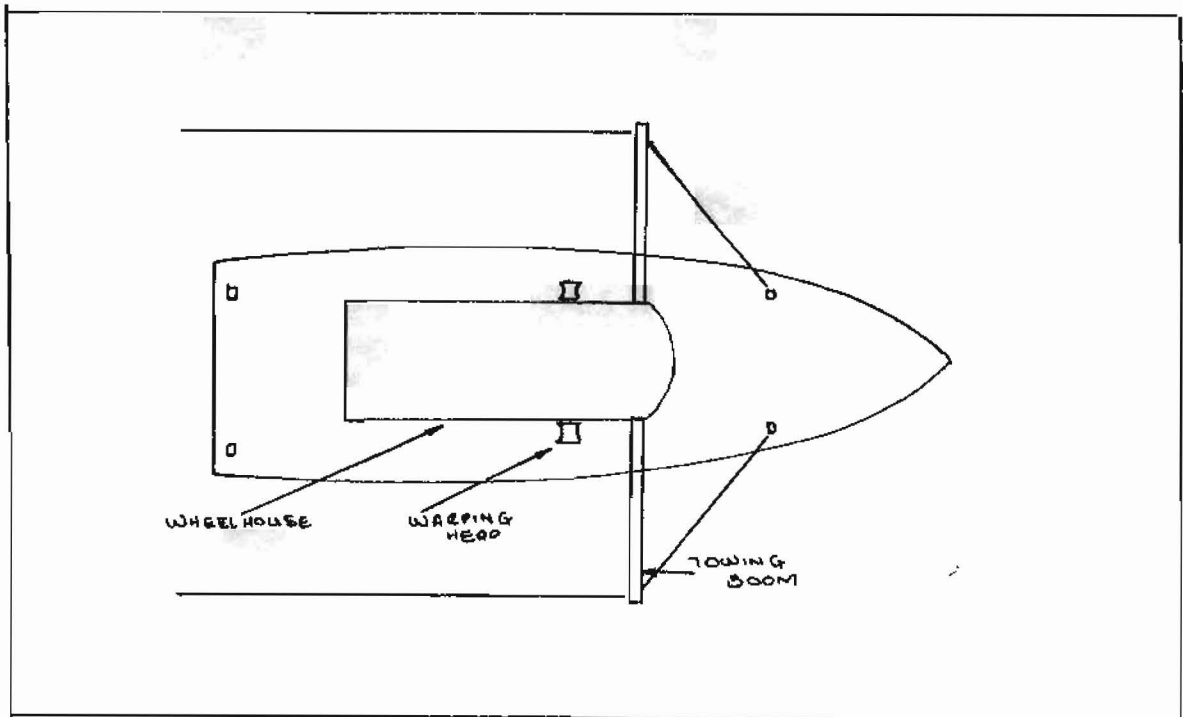

FIG. 3.1 THE TOWING OPERATION

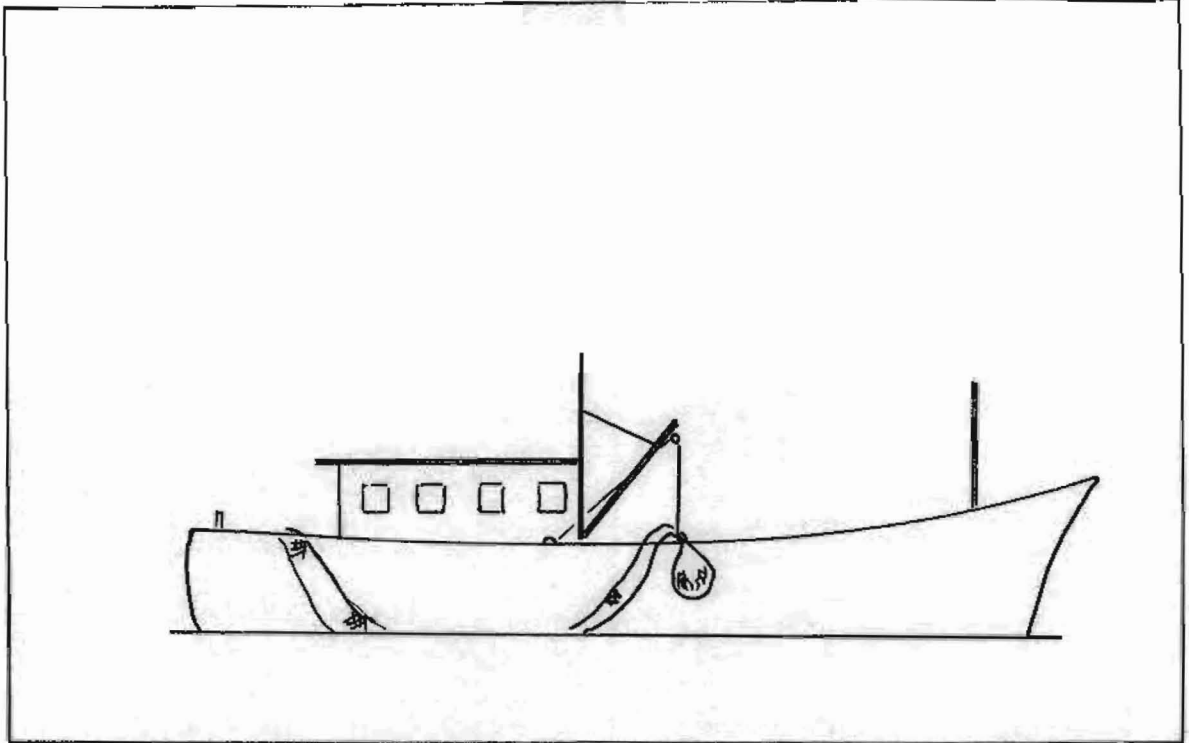

FIG 3-2 HAULING THE CODEND ABOARD

species of mullets, mackerel and prawns. Pelagic species such as herring and sardines are also caught in these demersal trawls. The catch is then sorted, graded, washed and iced in the holds.

The trawling method described is the predominant method practiced in Malaysia. New stern trawlers that are found in the fishery are in the east coast. These vessels are constructed similar in design to small trawlers (40-60 tons) found in the northern hemisphere. Fishing gear operations on these vessels are also similar. However, the equipment carried by these vessels are simple, locally made winches, while the navigation and electronic equipment is almost absent.

3.6. Trawling and the Fisheries Act

Under the fifth schedule (Regulation 4(4), Terms and Conditions of License for Trawl Fishing, several restrictions and regulations are specified for trawling. Important provisions include cod end mesh size of not less than one inch stretched.

Vessels of 100 gross tons or greater with 200 HP or greater shall only be used beyond 12 miles from the shore. Twenty-five tons and greater with 60 HP shall be used beyond 7 miles and those below 25 gross tons and less than 60 HP shall be used in waters beyond 3 miles from the shore. Fishing vessels of the third category can only fish in the daylight hours between 6:00 a.m. to 6:00 p.m.

3.4. Lay/Share System for Trawlers

Several types of wage schemes are found in the trawling industry. They may be wage system, share system or a combination of both. In a share system all running costs such as fuel, lubrication, ice, and food are subtracted from the gross revenue to give a net revenue. Shares are then divided from the net revenue.

Small trawlers:

It is just as common to have fixed wages or share system on small trawlers. With the fixed wages a monthly wage of \$80-\$150 is normal depending upon the skill and experience of the fishermen.

Small vessels are manned by a two-man crew. With a share system, the net revenue is divided in four shares. They are then divided as follows:

Boat owner - 2 shares

Crew member - 1 share each

Large vessels:

Similarly, both systems of wages are operated on large trawlers but the share system is more common of the two.

Fixed wages: \$130-\$250/month, depending on skill, experience.

Share system: The net revenue is divided into seven shares. The boat gets 3 shares, crew member 1 share and the skipper 1 1/2 shares.

It may be odd to see the skipper getting the same share as his crew member. However, as most skippers are also the owner of the vessel he also takes the boat's share.

In some areas, the Fishery Development Authority operates boats. The wage scheme on these vessels is a combination of fixed wages, share and bonus. All the crew members receive a fixed salary of \$160 a month. In addition the engine driver receives an extra allowance of \$170/month. In addition to the fixed wages, the crew members share 50% of the net revenue according to the shares below:

Captain	1 to 1-1/2 share
Crew member	1 to 1-1/4 share
Engine driver	1 share

A further \$30 bonus is given for every \$1000 of net profit. This is shared among the crew in the same proportion as the shares.

CHAPTER 4

4.0. Seining

The seines contribute 22.5% of the total landings in Peninsula Malaysia amounting to 127,200 m.tons in 1978. This figure represents an increase of 30.5% over the previous year's catch.

The seine group includes purse seining, two boat seining (pukat kenka) and other forms of beach seining (pukat kisa). While two boat seining is used primarily in the N.W. of Peninsula Malaysia (in the state of Perak, Kedah and Perlis), beach seining is commonly found around the country for subsistence and bait fishery. Both these gears are estimated to contribute only a small percentage of the total catch of the seine group making purse seiners the most important gear in the group.

4.1. Purse Seining

The main centers of purse seining in Peninsula Malaysia are Penang, Perak and Kedah in the west coast and Johore and Trengganu in the east coast.

4.1.1. Purse seing vessel:

The design and construction of purse seiners follow the traditional shape of fishing vessels in Malaysia. They are of wooden construction with the wheelhouse in the aft.

The hull is normally V-shaped, necessitated by traditional boat building methods and working deck forward of the wheelhouse. There are no formal galley or accommodations. Cooking is done on the port quarter. Sleeping quarters are arranged on raised platforms aft of the wheelhouse. In some instances where the vessel is maneuvered by means of a large tiller, the sleeping accommodations will be on the raised platform forward of the tiller.

The deck arrangement on these vessels is illustrated in Figure 4.0. Two warping heads on each side of the wheelhouse act as winches for the purse line. These warping heads run directly from the main engine by means of a mechanical drive through a gearing arrangement. Deck equipment

(See page following for Figure)

Fig. 4.0. Deck arrangement of a typical Malaysian purse seiner.

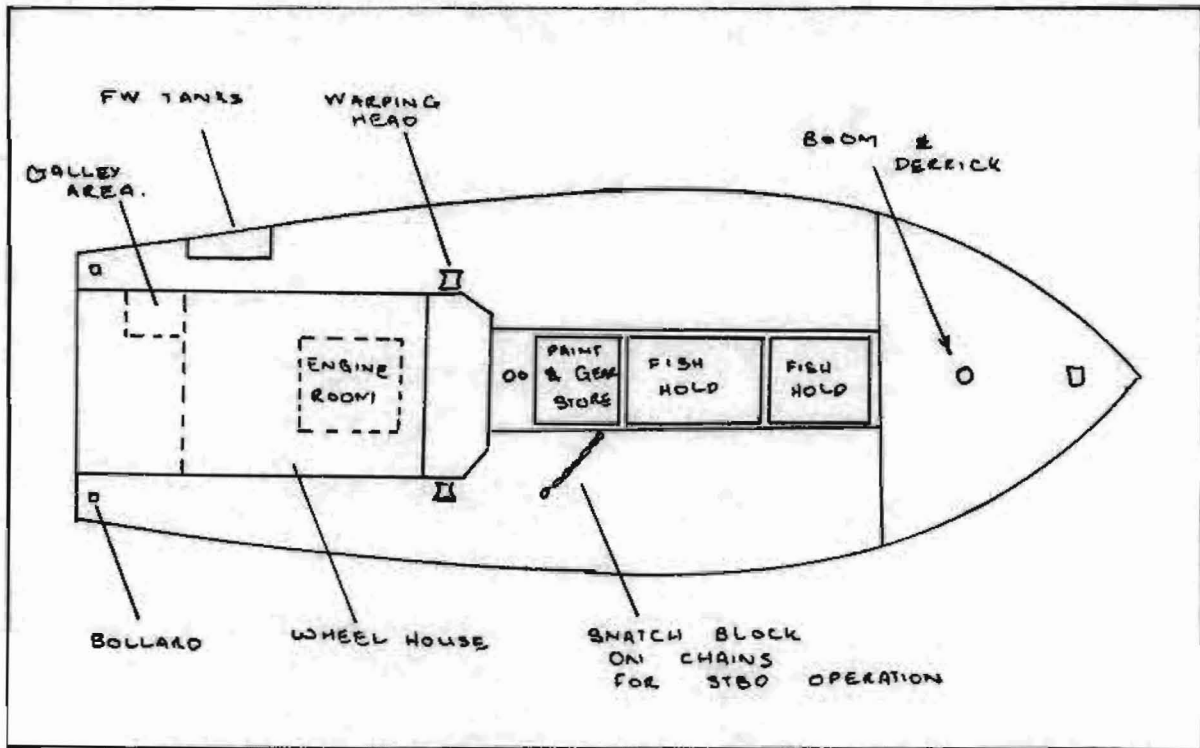

FIG. 4.0 DECK ARRANGEMENT OF A PURSE SEINER

on board is normally very simple and minimal but effective for the job at hand. It consists of an anchor, with manual or mechanical windlass, pursing blocks, running rigging, and brailers to haul the catch aboard. A small nonpowered skiff of approximately 14' x 5' is carried aboard, used in shooting the net.

The purse seine is stored on the starboard side of the vessel. The distinguishing feature of a purse seiner from other fishing vessels is a crow's nest or platform near the top of the mainmast where fish detection is done. In the east coast purse seiners carry 10-15 light buoys on the vessel used as a fish attraction device.

The normal dimensions of purse seiners are 45-65 ft. long and 14-16 ft. beam with gross tonnage of 35-70 tons. New additions to the fleet are in the 80-ton class.

4.1.2. Purse seines:

Basically there are two types of purse seines operated in Malaysia (Plans 4.1 and 4.2). Anchovy purse seines are normally 400 fathoms long and 40 fathoms deep. The mesh size used is 1/2" at the wing end, progressively getting smaller to 2/10" at the bunt in the center. The mackerel purse seine is normally 260-320 fathoms long and 42 fathoms deep with mesh sizes of 1".

Both types of seines are similar in design. A snag belt of larger mesh size and bigger twine surrounds the net. A certain measure of tapering towards the wing end of the

400 FTMS
400 FTMS
0.3 INS TEVLON
0.3 INS TEVLON

437.5 FTMS

400 FTMS
0.3 INS TEVLON

2400 FOAM RUBBER FL
8" x 3.5"

10 PL FL 16" x 5"



1.5M PE KNOTTED. 23400

24480

0.5" PA KNOTLESS

5940

3840 5760 4800

0.375" PA KNOTLESS
0.375" PA KNOTLESS

30600

0.5" PA KNOTLESS

4" PP KNOTTED.

3775.

216 PB TOTAL 50 LBS.

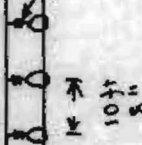

10 1/2
8"

430 FTMS
KUCALON Ø 1.2 INS.

1.8 LBS EACH.
BRASS.

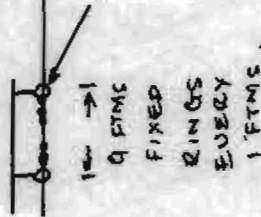

1" →
9 FTMS
FIXED
RINGS
EVERY
1 FTMS.

PLAN 42 MALAYSIAN ANCHOY PURSE SEINE

15
4
TSL
4"
PP



4"
PP
TSL



FE
Ø 1 1/2"

seine is achieved by bunching the two ends onto a 1-foot diameter metal ring. Variations in this feature are evident as some nets use 52 fathom depth pieces in the bunt and 42 fathom pieces on the wing. Other variations have developed mostly through the shippers' preference where parts of the net are differentiated by the use of different floats.

Knotless (raschel) nylon nets are normally used for the body of the net. Bottom snag belts are made either of polypropylene or saran nylon to decrease the amount of weights used. Although some nets use saran nylon material to increase the sinking speed of the gear, most nets are still made of nylon, preferring the strength factor of nylon compared to saran nylon.

4.1.3. Complement of the vessel:

The number of crew members on board varies from 15 in mackerel purse seine operations to 24 people in the anchovy purse seine vessel. The crew is divided into six categories of personnel according to duties and responsibilities.

An example of the manning of one vessel follows:

Skipper (Angkong)	=	1
Helmsman (Taikong)	=	3
Engine Driver	=	1
Fish spotter (orang tiang)	=	2
Cook	=	1
Crew member	=	<u>8</u>
Total	=	16

As evident later during the description of the operation, anchovy purse seining requires a processing vessel to follow the catcher vessel and process the fish immediately after capture. Six people are required to man the processing vessel as described below:

Helmsman	=	1
Chief processor	=	1
Processors	=	<u>4</u>
Total	=	6

4.1.4. Operations:

Four methods of operation are employed in Malaysia, namely:

- a) Mackerel purse seining
- b) Anchovy purse seining
- c) Lure line purse seining
- d) Purse seining using lights

The basic principle governing all the methods is common; i.e., the encircling of a school of fish, then the bottom of the net is pursed to create an artificial pond of netting containing the fish. The net is then hauled aboard progressively closing the artificial pond until the fish are concentrated in the bunt of the net for bringing the fish on board.

Considerable differences in operation have now developed in Malaysia evolving from differences of specie sought after, behavior and concentration of fish in the

east and west coast of Peninsula Malaysia. In the east coast except for anchovy purse seining, no large concentration of schools can be found, therefore, lure lines and light buoys are used to congregate the fish before a set is made. In the west coast, lure lines and light buoys are seldom used and fish is detected by fish spotters on dark moonless nights.

Mackerel Purse Seining

This method, also called night purse seining, is performed only on dark moonless nights and periods prior to the moon rise in the heavens. In one month the vessel can feasibly operate for approximately 20 days. The other 10 days, the vessels are tied up corresponding to periods of 5 days before and after the full moon.

The vessel normally leaves port at about 4:30 to 5:00 p.m. depending on the steaming time to arrive at the fishing ground before dusk. On arrival at the fishing ground the fish spotter stations himself on the crow's nest to detect fish schools. He is normally an experienced man who could determine the specie and size of the fish school spotted. Fish schools are located by sight.

The presence of fish schools is indicated by:

- a) Ripples in the water or schools jumping on the surface during periods of sunlight;
- b) Once dusk sets in, fish are detected by the presence of a slight red tinge in the water;

- c) On dark nights the sign to look for is a white shimmer in the water probably caused by bioluminescence as the school swims through the water.

After determining that the school is worth fishing for, the skipper replaces the fish spotter on the crow's nest. A set of signals are cleverly devised to denote speed and direction of the vessel between the skipper and the helmsman. In certain cases, by lifting his leg, the skipper directs the movement of the vessel. The amount of helm used is denoted by the degree of lift. Sound signals are used for the speed of the vessel; 1 blast for stop engines, 2 blasts for slow, and 3 for full ahead. Other methods of denoting directions are also common; i.e. by means of a manual rudder indicator operated by the skipper from his platform on the mast.

The skipper then determines the direction of the school carefully avoiding the school as it will dive if the boat hits the school. At this point any amount of white light, even if it is the lighting of a match, will cause the school to dive. Therefore, this operation is done in total darkness except for a small red light, located above the wheelhouse aft.

In the meantime the crew is already on standby. Two men go into the skiff attaching the appropriate lines ready to shoot the gear. The skipper positions the vessel

parallel and in the same direction as the movement of the school and shoots the net in a large circle encompassing the school of fish. Figure 4.1 illustrates the whole operation. As the large vessel approaches the skiff the front end of the gear is taken aboard by means of a messenger. Pursing then begins by using the warping heads. While pursing is in progress the vessel's engine is revved up and a large plunger is used on the water surface to drive the fish school away from the vessel towards the bunt end of the net.

Once pursing is done the net is hauled aboard from both ends using 5 to 6 men on each side (4.1.4). When the wing ends of the net are completely hauled aboard the catch is "dried up." The catch is then taken on board by means of a brailer and dumped into the fish hold. The catch is iced in a ratio of 2:1 fish to ice.

The net is now arranged on the starboard side of the vessel ready for the next set. Times for the various parts of the operation are as follows:

Shooting: 5 minutes; pursing: 10 minutes; hauling: 30-45 minutes; preparing the net 10 minutes. The whole operation takes 1 hour to 1.5 hours.

The vessel then continues its search for other schools. The number of sets per night depends on the time of darkness. On a dark night 6-8 sets are possible. Once the moon rises, the operation ceases and the vessel either returns to port or lays at anchor awaiting return to port.

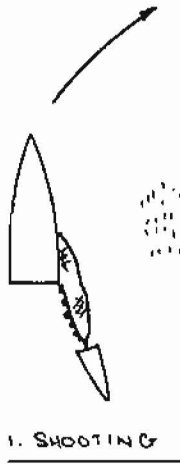

1. SHOOTING

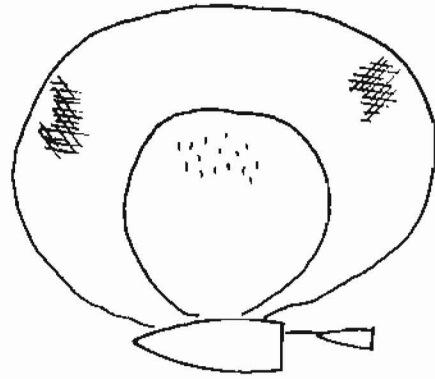

2. PURSING & BEGINS

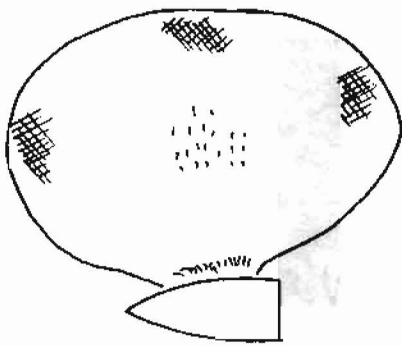

3. NET PURSED

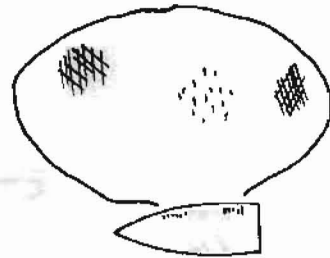

4. HAULING (BOTH ENDS)

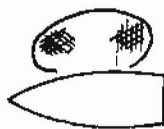

5 BRAILING

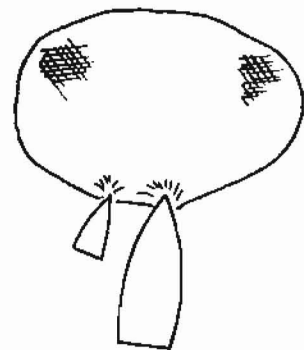

6 PURSING & HAULING IS SOMETIMES DONE FROM THE BOW

FIG 4.1 PURSE SEINING OPERATION

The vessel normally returns to port at 5:30 p.m. to enable the catch to be marketed on the same day.

Slight variations in operation occur where the net may be hauled at the bow of the vessel and hauling is done on board the vessel and skiff (4.1.6).

Anchovy purse seining:

This operation is done in the daytime. The purse seiner leaves port at about 5:30 a.m. and returns in the evening. This operation is done close to the shore and is characterized by the presence of a processing vessel. The catch is immediately transferred to the processing vessel where the anchovies are salted, cooked and brought back at the end of the day for drying on shore.

A typical cooker vessel is about 69'-00" LOA, 17'-00" beam, 6'00" ft. depth with a net tonnage of 62 tons. This vessel has a capacity of 18,000 lbs. with some eight large gas cookers to process the catch.

As the operation is done even as close as half a mile from shore, care is given to the movements of currents so as not to jeopardize the safety of the vessel and its gear. As a general rule operations are done closer to shore during ebbing tide and further out to sea on rising tide.

Purse seining using lure lines and/or lights:

This method of operation is common in the east coast of Peninsula Malaysia. As there are no large schools to

be found, schools of fish are congregated by means of lure lines in the daytime and light buoys at night.

A lure line is a line anchored on the seabed running through the water column to the surface. Coconut fronds and other leaves are tied in bunches at 2 fathom intervals to act as a shelter and attract fish. These lines are permanently set at sea in clusters of 15-20 units.

In the daytime the purse seiners will go out to these lure lines. An experienced fisherman, knowledgeable in the methods of fish detection named the diver inspects the concentration of fish by sight and sound and determines whether to combine the fish from different lure lines or shoot around one lure line if the concentration is large.

The diver determines the size of the school and type of fish by the noise of the fish and its swimming action through the water.

Before setting the net, the fish is transferred from the anchored lure line to a lure line carried on a small skiff by detaching the anchored lure line from its buoys and letting it sink. The purse seine is then set around the lure line (Fig. 4.2).

If there is a need to concentrate the schools, then the skiff will take the mobile lure line visiting each main lure line in turn sinking it and by his action transfer the fish school to the mobile lure line.

At night the functions of the lureline are replaced by the lighted buoys illustrated in Figure 4.3. As expected

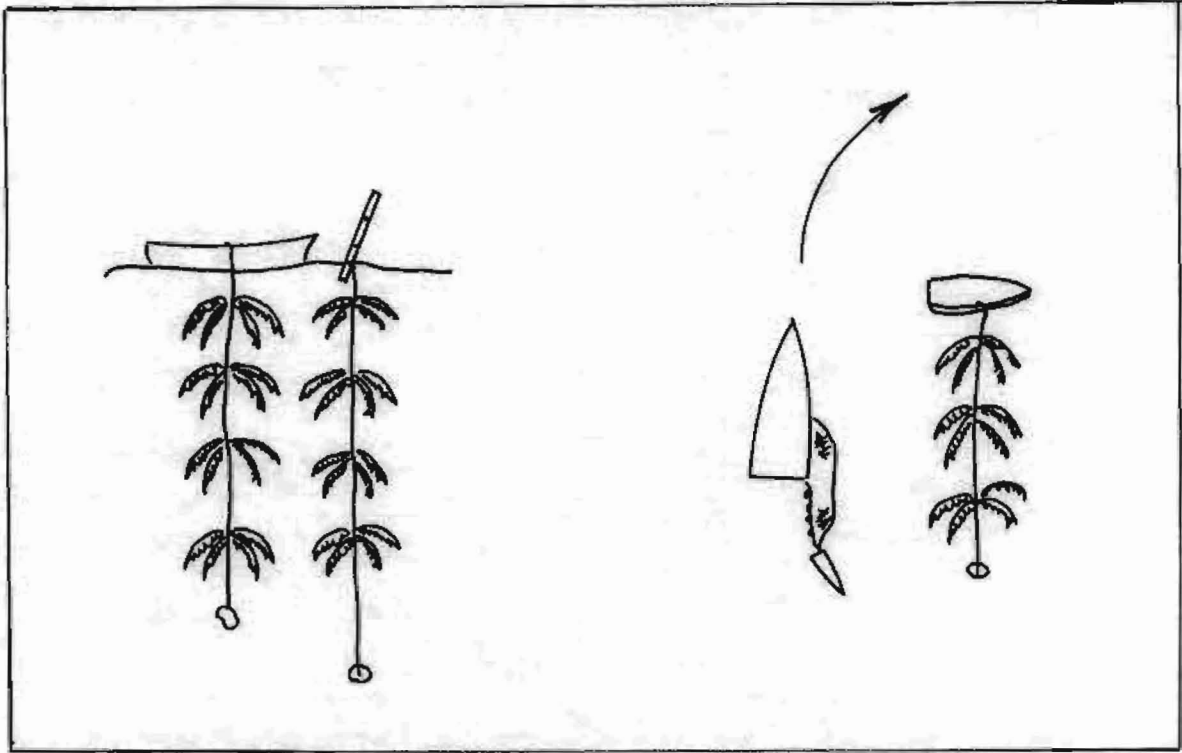

FIG. 4.2 TRANSFER OF FISH FROM ANCHORED TO
MOBILE LURE LINE - SHOOTING THE
GEAR

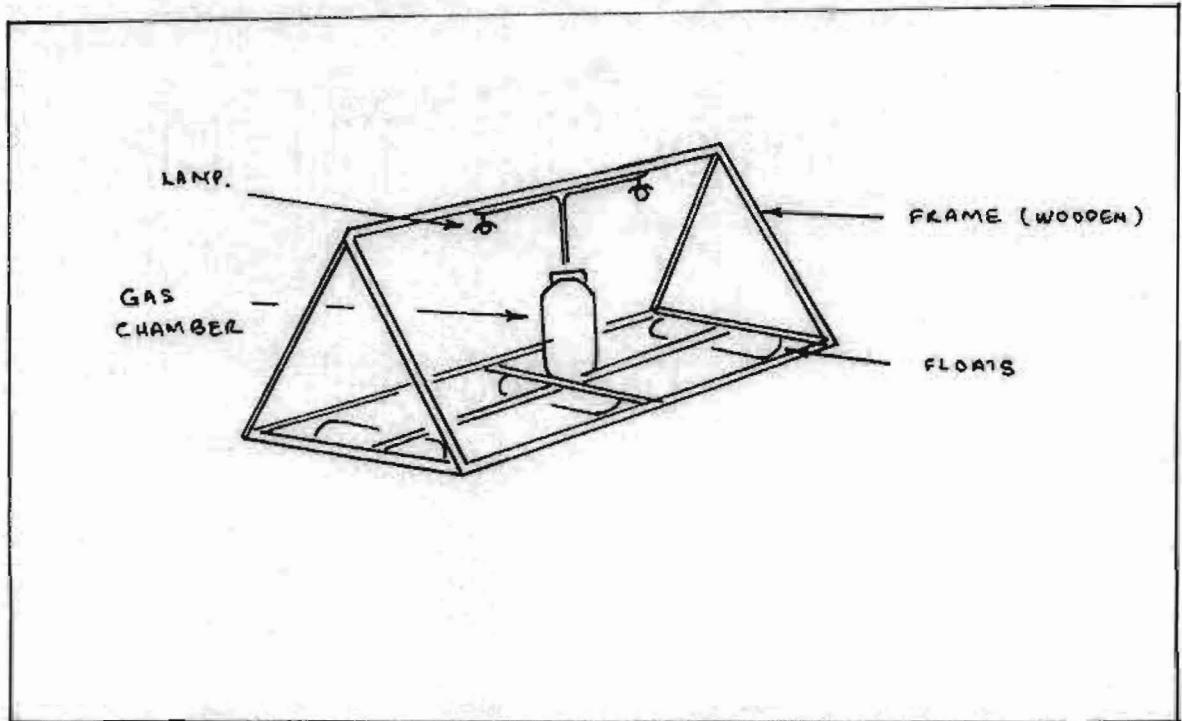

FIG. 4.3 LIGHT BODY

this operation can only be performed on dark moonless nights as fish do not surface and congregate on moonlight nights in accordance with normal diurnal migration.

In 1978, the South China Sea program brought sophisticated purse seiners from Belgium and Canada to determine the feasibility of operation in the South China Sea. Unfortunately these vessels were totally unsuccessful in their operation. This project has since been abandoned. In their subsequent reports, reasons for their failure were attributed to: a) no large schools of fish; b) the nets used were slow sinking to catch the fish; and c) unsuitability of such operation.

4.1.5. Share system/lay system in the purse seine fishing

An intricate share system is employed in the northwest sector of the industry; i.e., in Perak. A system of fixed wages, share and bonus is employed. Trip expenses, large or small, are first deducted from the total revenue. Fixed wages are then paid as follows: skipper = M\$320/month, helmsman, fish spotter, cook and engine man, each = M\$120/month, crew member = M\$90/month.¹

After the first 10,000 lbs., a share system is employed. Shares for various categories of ship's staff are shown below:

Skipper = 2 shares

Helmsman, fish spotter, cook and engine man = 1.5

Crew = 1 share

¹M\$2.1 = US \$1.00.

Bonus is also given at a rate of M\$1-2 for the skipper, .60 cts. for the helmsman, etc. and .40 cts. for the crew for every 100 lbs. over the first 10,000 lbs. For these portions of the share system, fish is bought by the boat owner at about 10% of its market price.

In addition to the above, another type of bonus is given called "Hokia." This is the portion of the catch that the boat owner will pay the crew at the full market price. The ratio of portions bought at full price is given below:

<u>Catch</u>	<u>Hokia</u>
10,000 lbs.	400 lbs.
25,000 lbs.	600 lbs.
60,000 lbs.	700 lbs.
90,000 lbs. and above	1100 lbs.

These revenues are paid according to the shares.

Finally there is a provision called "take home fish" where crew members are allowed to take home fish at pre-determined proportions. However, these may not exceed 65 lbs. Normally, the crew may in turn sell these fish at market prices.

Another method of share system is practiced in the Selangor and its vicinity. In this method net revenue is obtained by deducting all trip expenses (TE) from the gross revenue (GR).

Thus, $GR - TE = \text{Net Revenue}$

The net revenue is then divided as follows:

Boat owner = 4.5 shares.

Skipper, Engineman and Fish Spotter = 1.5 share, and
the rest of the crew = 1 share (9 crew members).

4.2. Seining

Seining method employed in Malaysia is somewhat similar to the Scottish seining method whereby the net is towed for some distance to close the seine warps prior to hauling the gear. This fishing method has evolved from a one-boat operation to a two-boat operation. The two vessels are generally of similar dimensions and closely equal horsepower. A typical seine boat has the dimensions of 36'-00" long, 7'-00" wide and a depth of 2'-00" with a gross tonnage of 5.5 tons.

4.2.1. Principles:

The catching principle of a seine net is to encircle an area with the net and warps. As the warps are towed they cause a cloud curtain as they pass over the seabed. This cloud curtain has a herding effect on fish and other demersal species. The net then collects the fish that have congregated between the warps. Seine nets are very effective on demersal species tight on the sea bottom such as flatfish and shrimp.

4.2.2. Seine net:

The seine net has close resemblance to a trawl net except that it is lower in headline weight and has a proportionately longer wing than the trawl.

The headrope and footrope is about 60 fathoms long. Unlike a trawl net a seine net has no overhang.¹ The netting material used is nylon with a mesh size of 3/4 inch throughout. The plan drawing of seine nets is illustrated in plan 4.3.

4.2.3. Operation:

The seine net is operated close to the shore, mostly in waters of less than 5 fathoms. The fishermen spend 8-10 hours in the fishing ground operating the gear 4-6 times in the day.

The operation of this gear is very much affected by tides. The net is set and hauled with the tide. This mode of operation increases the sweep area of the gear. During neap tides the catching efficiency of this gear drops tremendously, consequently no operation is done.

On arrival at the fishing grounds an anchored marker buoy is thrown overboard. The boat is left to drift to determine the direction of the tide. One end of the seine warp is then shot attached to a buoy. The vessel then pays the warp at first against the current while slowly making a large semi-circle. This is illustrated by Figure 4.3.

¹Footrope lag behind the headrope when the net is in operation.

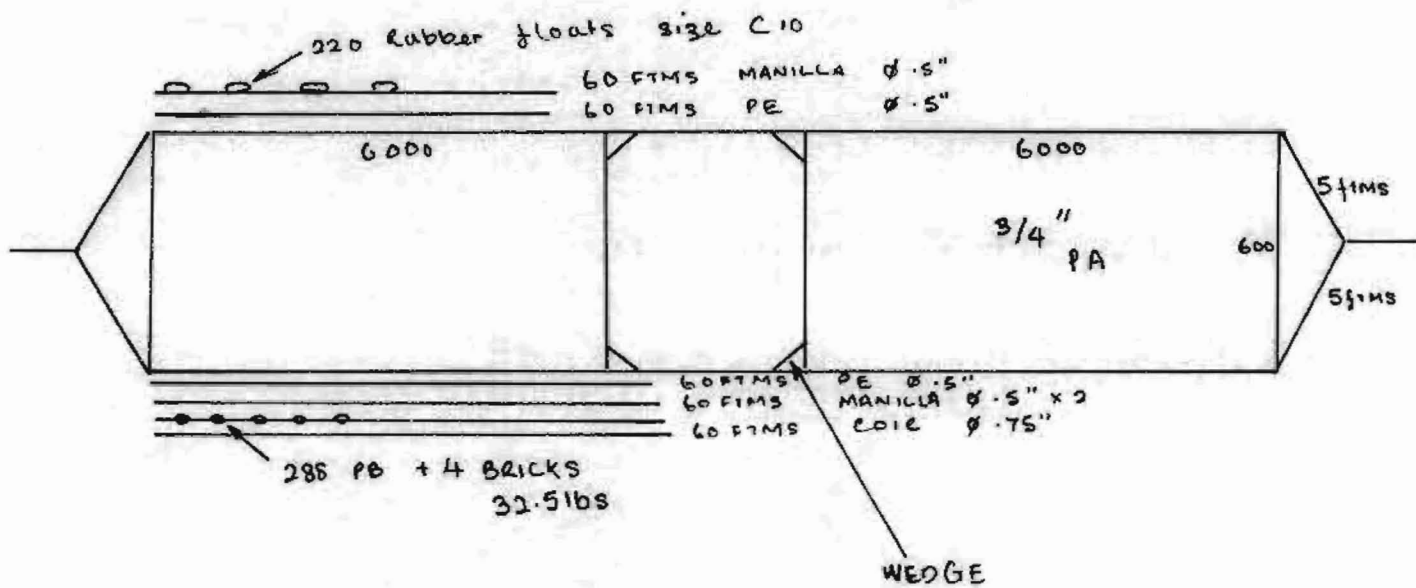
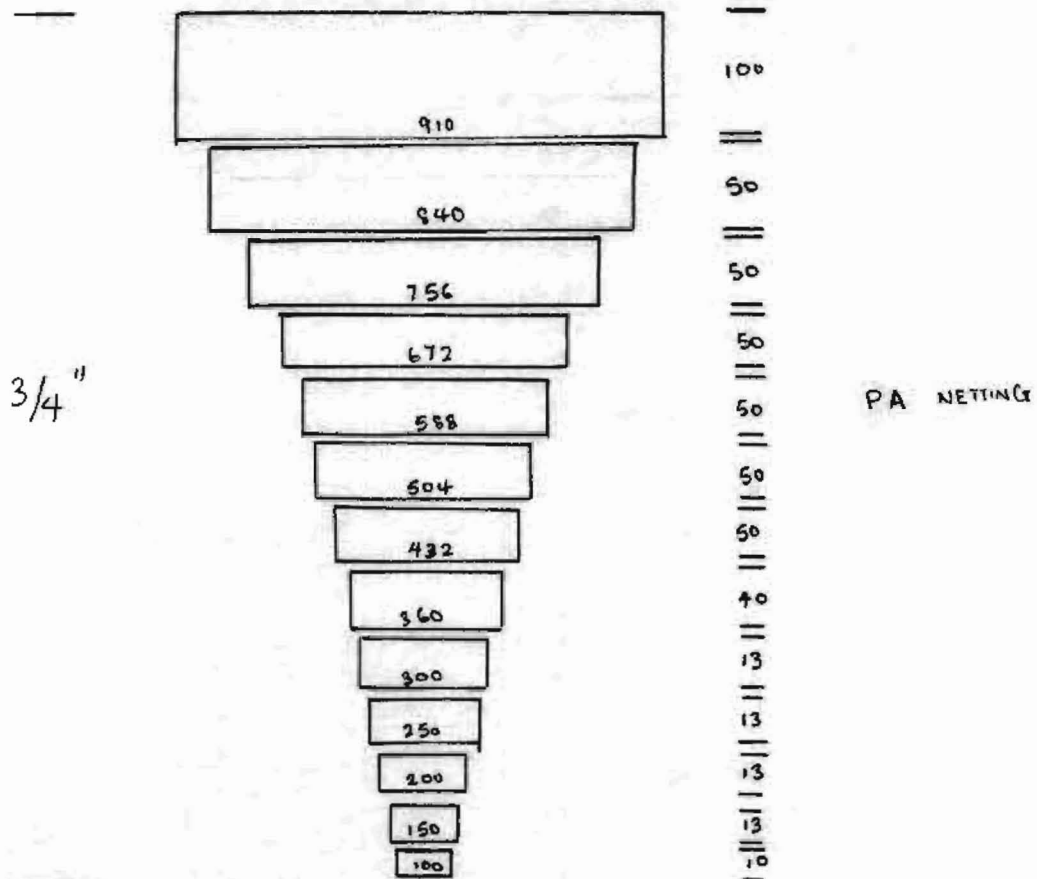

PLAN 4.8 SEINE NET.

The towing vessel then picks up the buoy and attaches it to a stern post ready to start the tow. Meanwhile, after paying the first warp the mother vessel pays the net followed by the second warp. Figure 4.4 illustrates this operation.

On completion of paying the second warp the towing operation begins. The towing angle between the two vessels is approximately 100° . Towing is done for approximately 20 minutes then the two vessels come together. At this point the two vessels pick up speed, the idea being to catch the fish that are now congregated. Both vessels then stop engines. The first warp is transferred to the mother vessel. Crew members from the towing vessel then go aboard the mother vessel to assist in the hauling process. Hauling is done manually with the mother vessel broadside to the wind and the net. During this process the towing vessel is tied leeward from the mother vessel. A sea anchor is used to ensure the vessel is kept broadside to the gear and does not ride over it. Figure illustrates the hauling process.

The main catch of this gear are the different species of shrimp and demersal fish, especially those found close to the bottom such as flatfish. The catch is sorted and iced to be sold to a wholesaler.

4.2.4. Lay/share system:

There are six crew members involved in a seining operation. Net revenue is shared into 9 shares and these

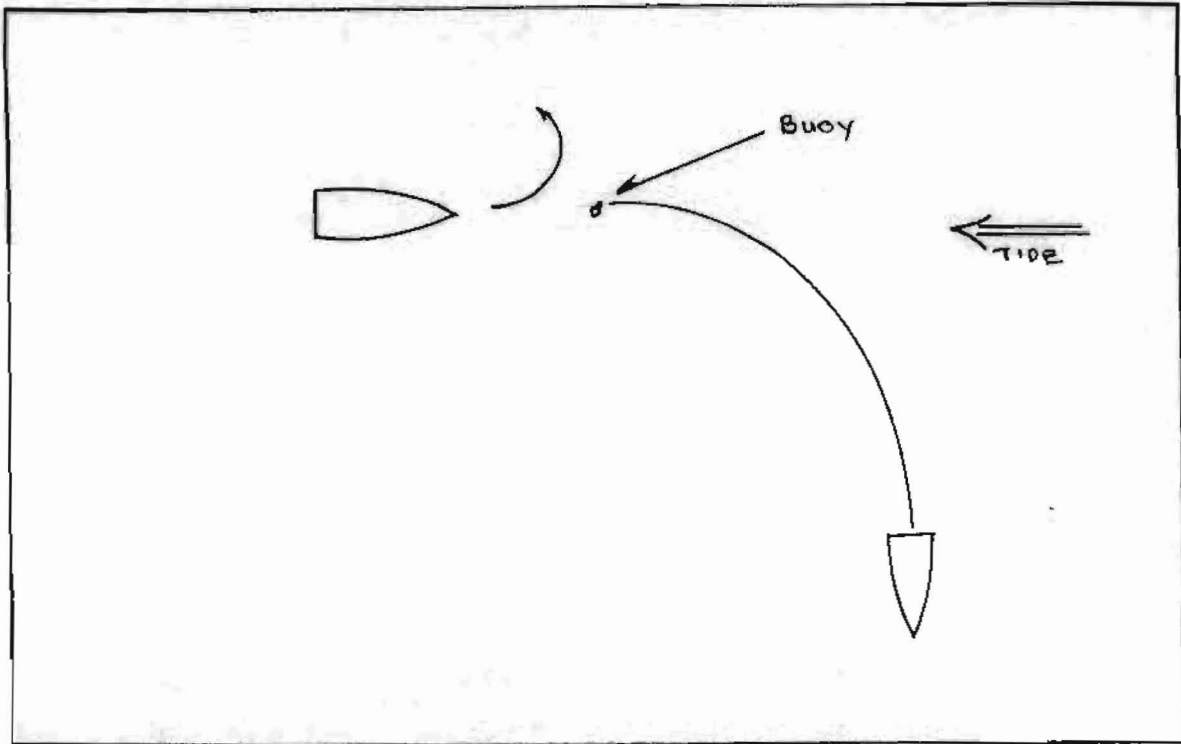

FIG 4.4 SHOOTING THE SEINE NET

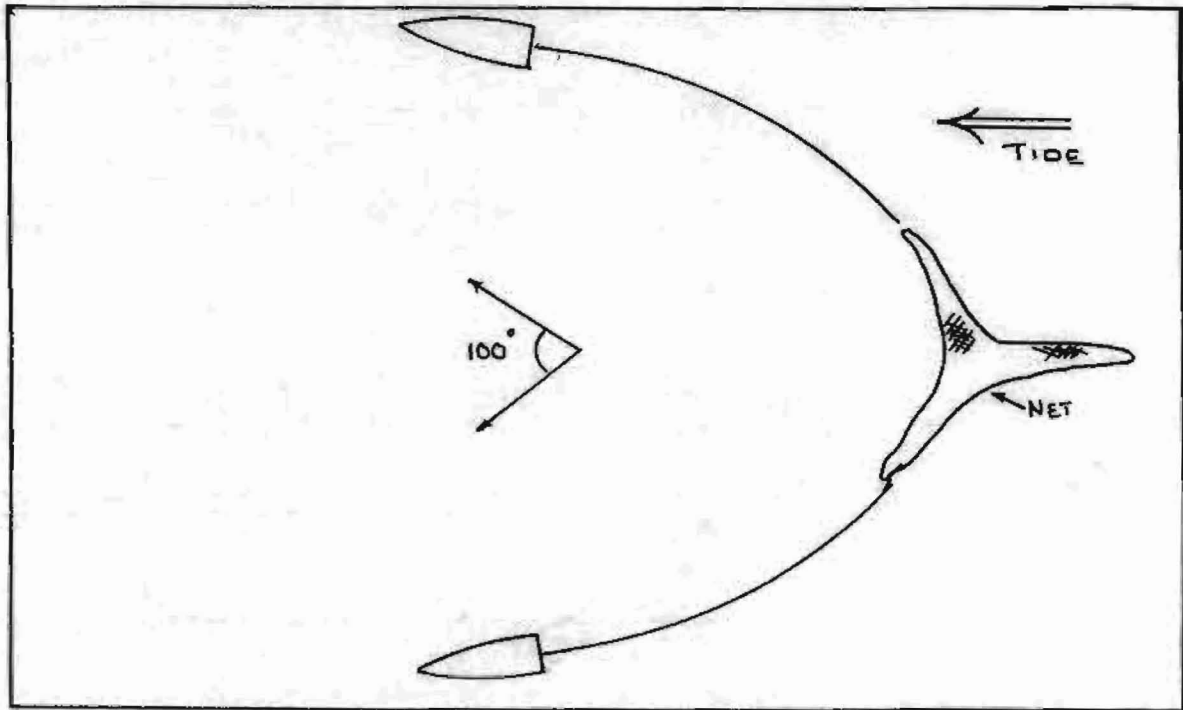

FIG 4.5 TOWING THE SEINE NET

are divided as follows:

Boat owner	2	shares (1/boat)
Net owner	1	share
Skipper	1	share
Engine driver	1	share
Crew	1	share each

CHAPTER 5

GILL NETS/DRIFT NETS

The fourth most important gear is the gill net group. There are 12,494 licensed units in the fishery. In 1978 it landed some 81,508 metric tons, an increase of 89% over the 1977 catch. Reason for the popularity of the gill net is its small capital outlay. A large variety of vessels operate the gill nets. It ranges from small rowing boats to inboard powered 25 gross ton vessels.

Principle:

The principle of the gill nets is gilling and enmeshing. The net is set vertical in the water at varying lengths normally 30 ftms long x 50 pieces. Schools of fish unable to detect the net strike the net and the gills get caught in it. Consequently the fish struggle and are sometimes enmeshed into the net.

The trammel net is a three piece gill net of small mesh, sandwiched between two large mesh nets. These gears are used on the seabed primarily for catching shrimp.

5.1. The Net

There are numerous types of gill nets ranging in mesh sizes from 1-1/2" (prawn gill net) to 7". Two types of netting materials are primarily used - monofilament or nylon

nets. Monofilament nets have weighted footropes, while the nylon nets have a 15 inch deep belt of saran netting at the foot of the net to replace the weights of the footrope. Saran being heavier than water will keep the nets vertical in the water.

Names given to these nets correspond to the species of fish they are intended for. Plans I, II and III illustrate three types of net operated. These nets exhibit longer footropes than headropes. This gives a crease effect at the bottom of the gear necessary to retain as much fish as possible.

5.2. Operation

Gillnet operations can be operated any time of the day or night. The operation is very much affected by tides. During periods of rip tides no fishing is carried out because of poor catches. The nets are normally prepared in the forward hold before arriving at the fishing grounds. Two types of shooting operation are common.

Shooting while going astern:

The gear is shot out perpendicular to the tide while the boat is going astern (Figure I). During the shooting one man steers the vessel while the other shoots the net. In some operations the engine is shut off and the vessel drifts with the tide. In this instant large oars are used to steer the vessel. Figure 5.1 shows the set in the water.

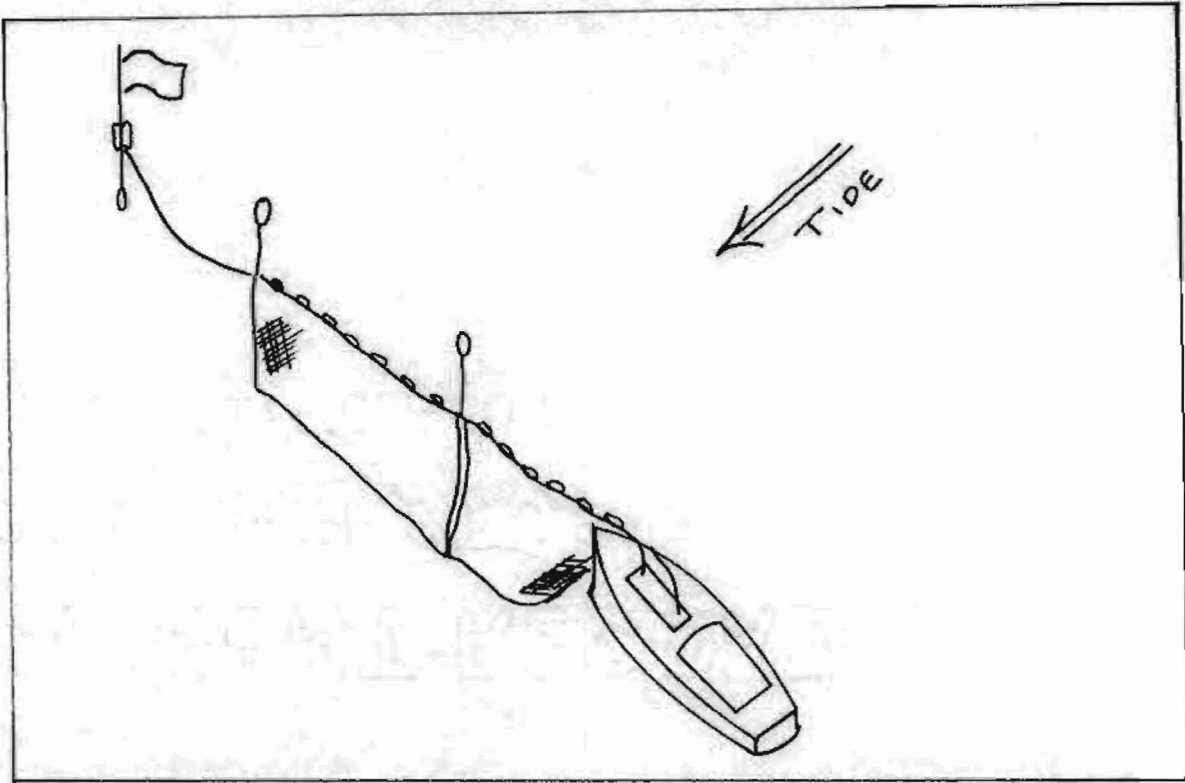

FIG. 5.0 SHOOTING THE NET

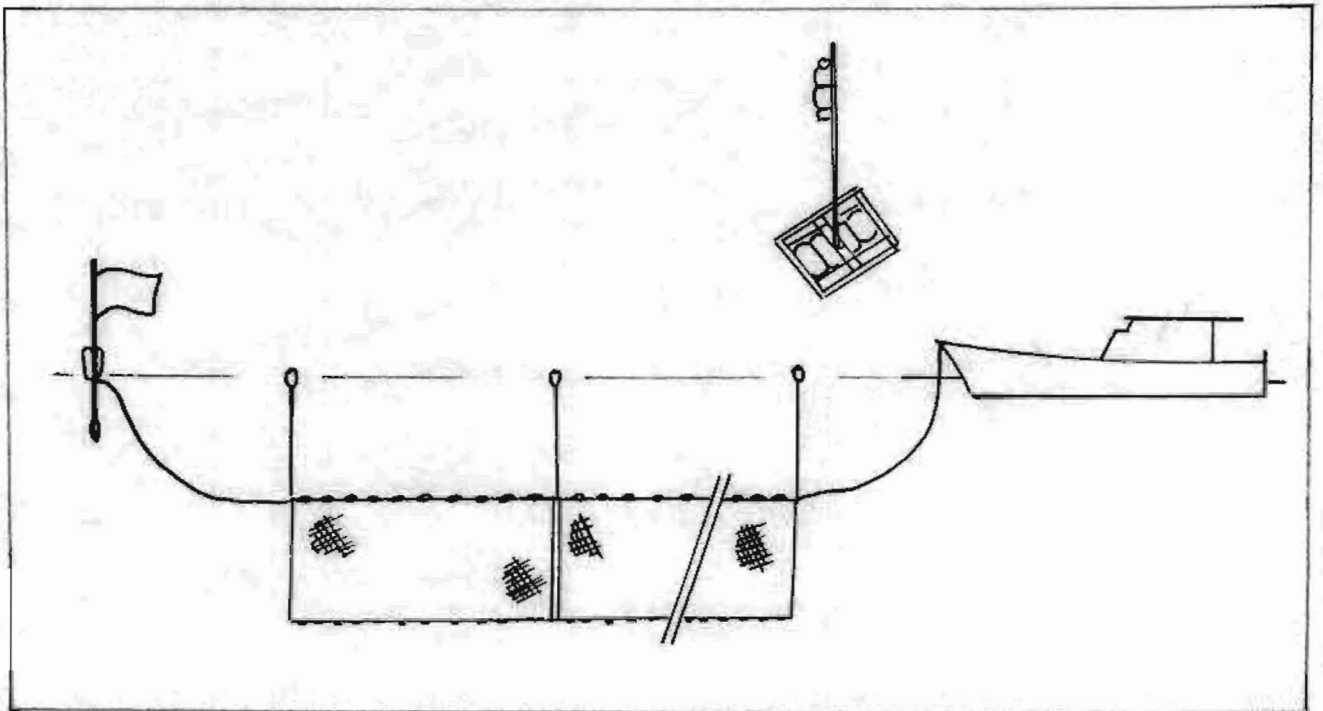

FIG 5.1 A GILLNET SET IN THE WATER

INSERT - LIGHT BUOY FOR NIGHT OPERATION.

Floating/drift gill nets are fished 2-3 fathoms below the surface. Besides catch considerations, this allows the other vessel to go over the net without snagging it. The last end of the net is attached to the vessel while waiting to haul the gear. In night operations, the flag buoys are replaced by light buoys. Figure 5.1 shows a light buoy. Shooting time will depend on the number of gill nets used. A 50-piece set normally takes about 40-60 minutes.

Shooting the gear while going forward:

With certain nets such as the threadfin gill net, the nets are set while the vessel is going forward. The nets are prepared in the net hold. These vessels have low gunswales and no protruding parts in the path of the outgoing nets. Flat boards are fitted over parts of the boat which may catch the net while shooting.

Again the nets are laid perpendicular to the tide in an elongated C. Figure 5.2 illustrates this.

The vessel starts shooting with the tide on the port beam, takes a large turn to point B and finishes the set at point C. The set only takes about 10 minutes with the vessel going almost full speed ahead. According to the fishermen, the corners in the set help to trap the fish. The vessel then drifts on the leeward side of the net for three to four hours before hauling.

Hauling:

Hauling is done in the starboard bow, one man hauling the head rope while another the footrope. Fish caught

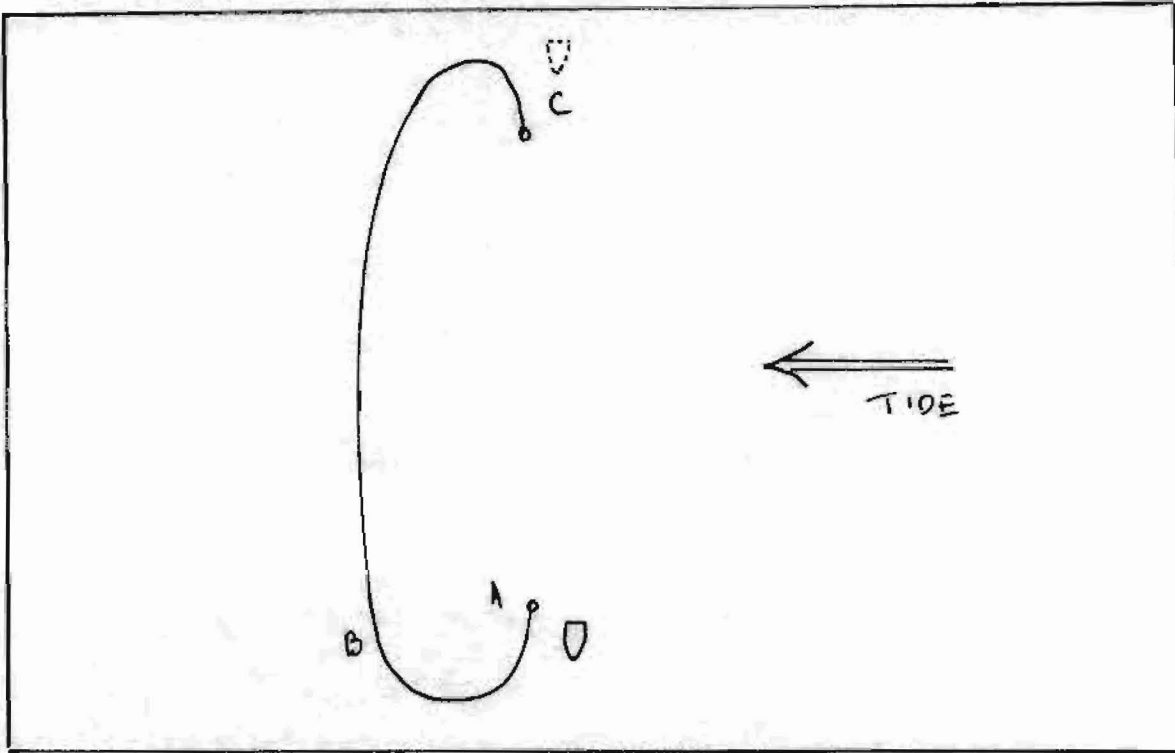

FIG 5.2 THE THREADFIN GILLNET SET

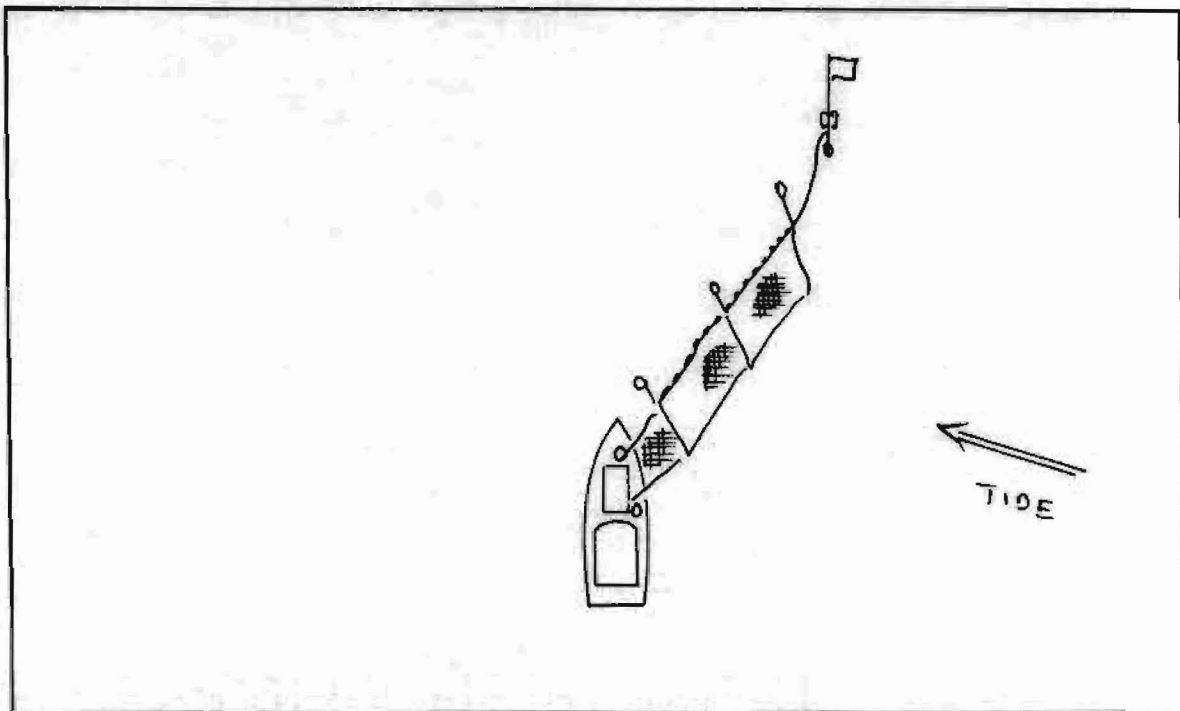

FIG 5.3 HAULING THE NET

are placed on deck. The engine is kept running at neutral and used occasionally for course correction to keep the net about 2 points on the starboard bow. Position of the vessel in relation to the net and tide is shown in Figure 5.3. The net is stored carefully in the hold ready for the next operation. Normally two operations are done in one day. Fish caught are sorted, graded, washed and kept in net baskets under ice in the holds.

5.3. Lay System

Three types of lay system are used in the industry; viz, share system, fixed wages and percentage of gross. As the gillnet fishery is mostly run as a family operation, various other schemes are also found in the fishery. However, the three systems described below are a close representation of the present situation.

Share system:

With the share system, ice, fuel and food are deducted from the gross proceeds.

The net revenue is then divided into 5 equal shares. The boat and net (accruing to the owner) receives three shares while each crew member will receive 1 share. All maintenance costs are borne by the owner.

Fixed wages:

A system of fixed wages are also employed. In this scheme the fishermen receive \$100-\$200/month with food provided for the trip.

Percentage of gross:

Yet another system determines wages as a percentage of gross. Normally 18 percent of gross revenue is given to the fishermen. In this system food for the trip is provided for by the boat owner.

5.7. Trammel Nets

Trammel nets are widely used only in the west coast fishery. These are anchored nets operated on the seabed primarily used for catching prawns. The catching principle of the net is tangling and enmeshing.

Plan 5.4. illustrates a constructional plan of the net. The nets are made of nylon twine with 1-3/4 inch meshes in the center netting and 10-inch meshes in the two outer netting. A 2-inch border is used at the headrope and footrope of the net. Each piece of trammel net is 35 fathoms long and 1.5 fathoms deep. Twenty-five to thirty nets are used in one setting. The net is operated similarly to other gillnets except for two anchors placed at the extreme end of the set.

The prawns are placed in a five-gallon can containing seawater. Premium prices are obtained if the catch is landed alive.

Fish caught in the net are washed, graded and stored in ice in the holds.

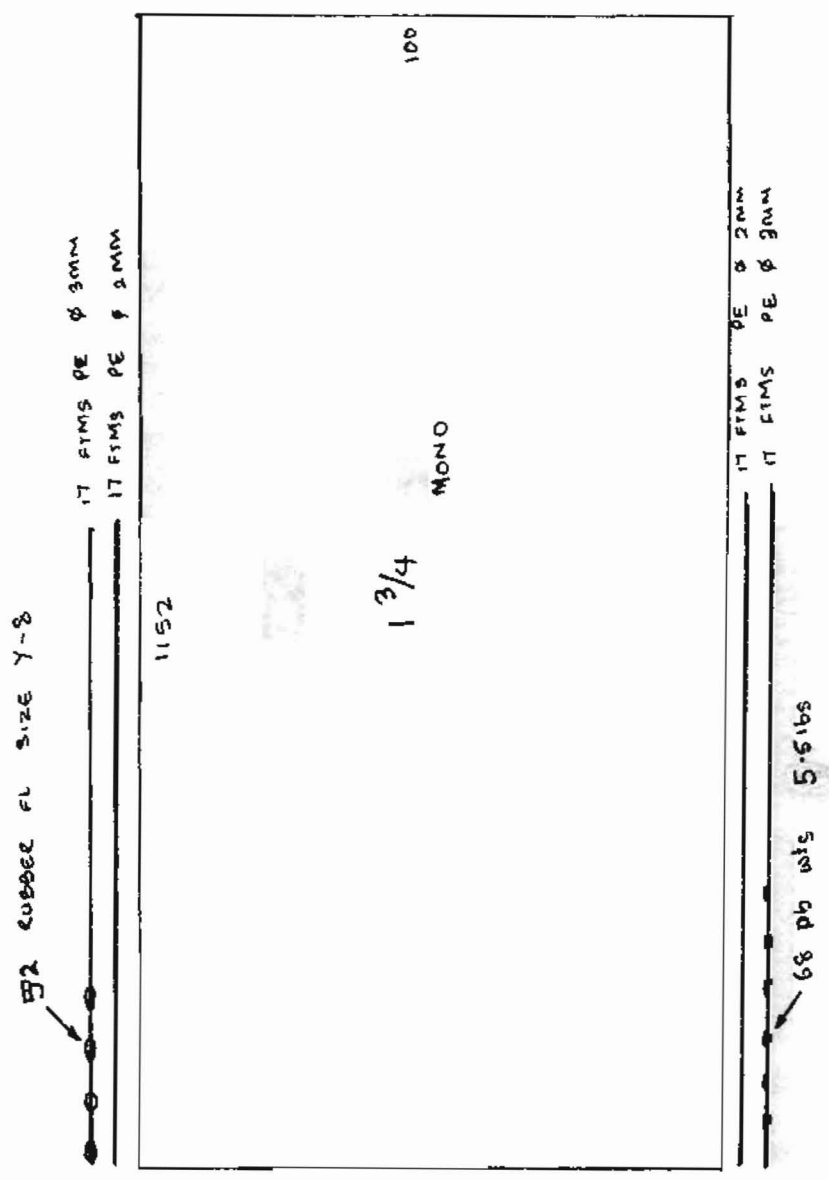

PLAN 5-1 THREADFIN GILL NET

3 large PL FLOATS
11" x 5"

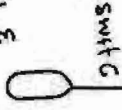

25 PL FLOATS size 7-8.

125 ft PE 4 mm
125 ft. PE 3 mm.

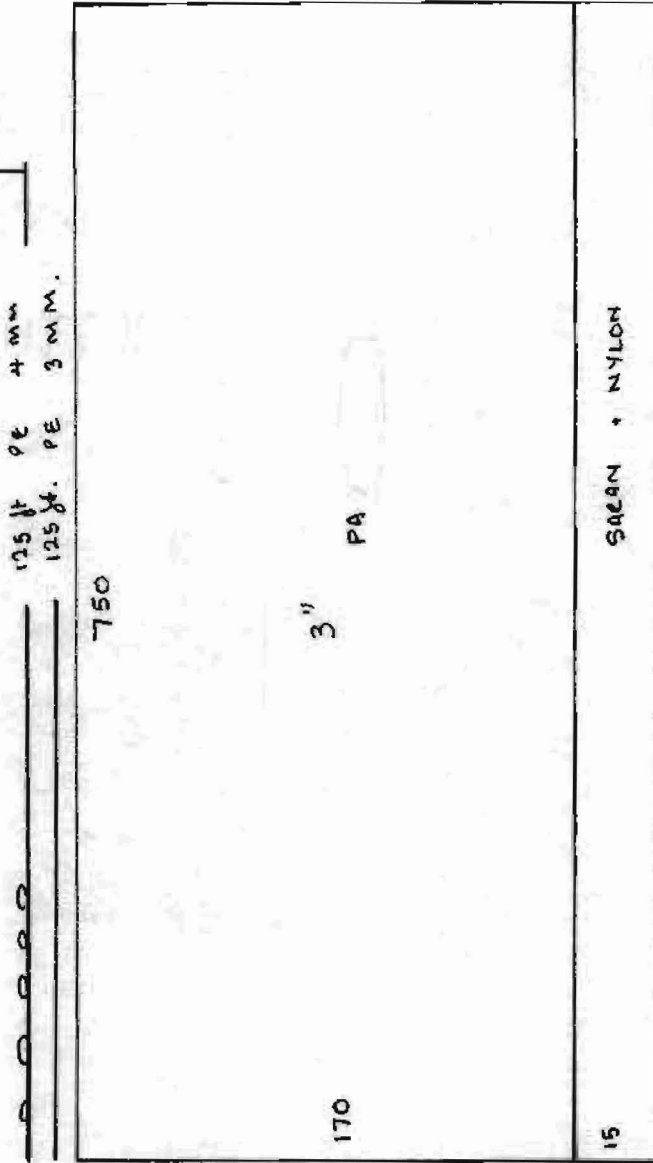

SARAN + NYLON

PLAN 5.2 SPANISH MACKEREL / WOLF HERRING GILL NET

22 RUBBER FLOATS
(8" x 2")

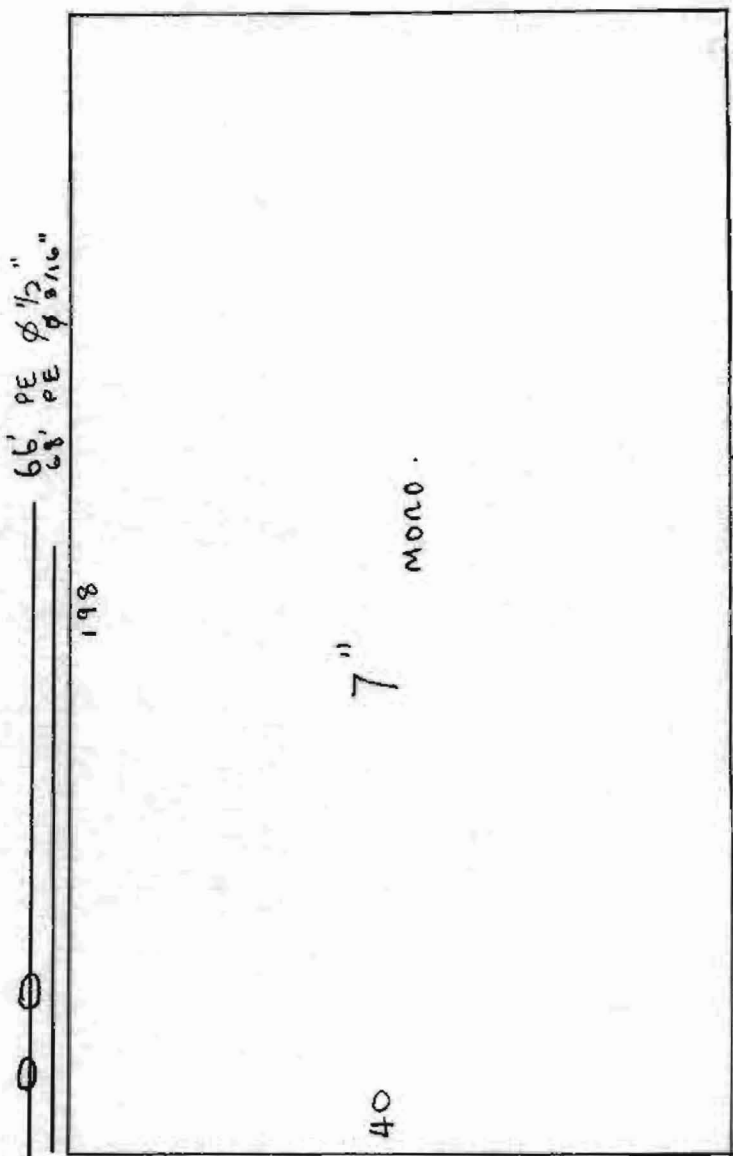

66' PE ϕ 1/2"
68' PE ϕ 3/16"

68' PE ϕ 3/16"
66' PE ϕ 1/2"

110 lb wts 10 lbs

PLAN 5.3 THREADFIN GILL NET (SENOHONG)

53 PLASTIC FLOATS (75 x 1.5")

105 ft. PE 4 MM
105 ft PE 3 MM

2"

1728

56 1 3/4"

MONO

10 X 10" MESHES
192 M.L. PA.

2" 1257

106 ft PE 3MM
106 ft PE 4MM

119 lb wts 4.5 lbs

PLAN 5.4 TRAMMEL NET.

CHAPTER 6

LIFT NETS

The lift net group produced about 10,460 M. tons of fish in 1978. Gears representing this group include the spoon net and 5 boat lift nets (pukat tangkul). Although some states in the east coast of Peninsula Malaysia operate these gears (Kedah, Selangor and Penang), lift nets are primarily operated in the east coast of Peninsula Malaysia.

There are a total of 430 vessels operating the lift net. All these vessels are below 50 gross tons.

Principles of operation:

Similar to the blanket net of the Philippines the five boat lift net operates on a principle of attracting a school of fish and lifting a net previously set below it to trap and capture the school.

6.1. The Net

The lift net is normally a square net 40 x 42 fathoms and made of such material as Livlon or saran nylon to facilitate sinking of the net. Figure 6.0 shows the plan of a lift net. Some six different mesh sizes are used ranging from 4" at the corners to 1/2" in the center belly.

6.2. Operation

The five boat lifenet as the name suggests, is operated by five boats. The whole fishing unit may consist of between 25-32 people. Between these five boats two nets are used in the operation. One of the boats carries the fishing skipper who performs the important task of locating the fish schools. This person called the diver will determine the availability of fish and whether a set should be made.

This operation is dependent upon attraction and schooling of fish by the use of lure lines. The use of lure lines to attract fish have been described in the purse seining operation using lure lines. Operation with the five boat lift net is somewhat similar (refer to Section 4.1.4).

6.3. Fish Detection Methods

The traditional method of fish detection is an art brought down from generation to generation of fishermen. It is the traditional belief that only certain people are gifted or meant to be blessed with the qualities needed to be good "divers."

The technique of detecting fish is the ability to use effectively the combination of the faculties of hearing, sight and feeling.

First and foremost the diver must be able to detect the inherent sounds of the sea. For instance he must be able to recognize the sound of soft bottom, hard bottom or simply the sound of the sea. Once this is achieved

then it is just a matter of dissociating the sound of the sea from that of fish.

Different species of fish give out different characteristic sounds. For instance Indian Mackerel sound like wind blowing through the trees. Scads make noises that sound like frying fish. Sardines produce a tapping sound in the water while the gold banded scad only makes sounds while it dives, sounding like cracking wood.

As a caveat it must be understood that these sounds are not absolute. More than anything else it must be recognized that these are the diver's interpretation of what he hears and feels. However, the sounds recorded above are a general consensus of different divers.

A good "diver" should be able to recognize species, directions and size of the school to determine whether the gear should be set.

After deciding that the size of the school is worthwhile, he signals the others to set the gear. The net is set leeward of the school in relation to the current as shown in Figure 6.0. The two forward vessels are anchored while the other vessel may or may not be anchored depending on the strength of the tide.

The diver's vessel carrying the mobile lure line congregates the fish and slowly takes it into position at the center of the set net. On his signal hauling begins. Once the net is hauled to the surface and most of the webbing taken aboard, the net is transferred to two vessels to handle the catch. (Figure 6.1.)

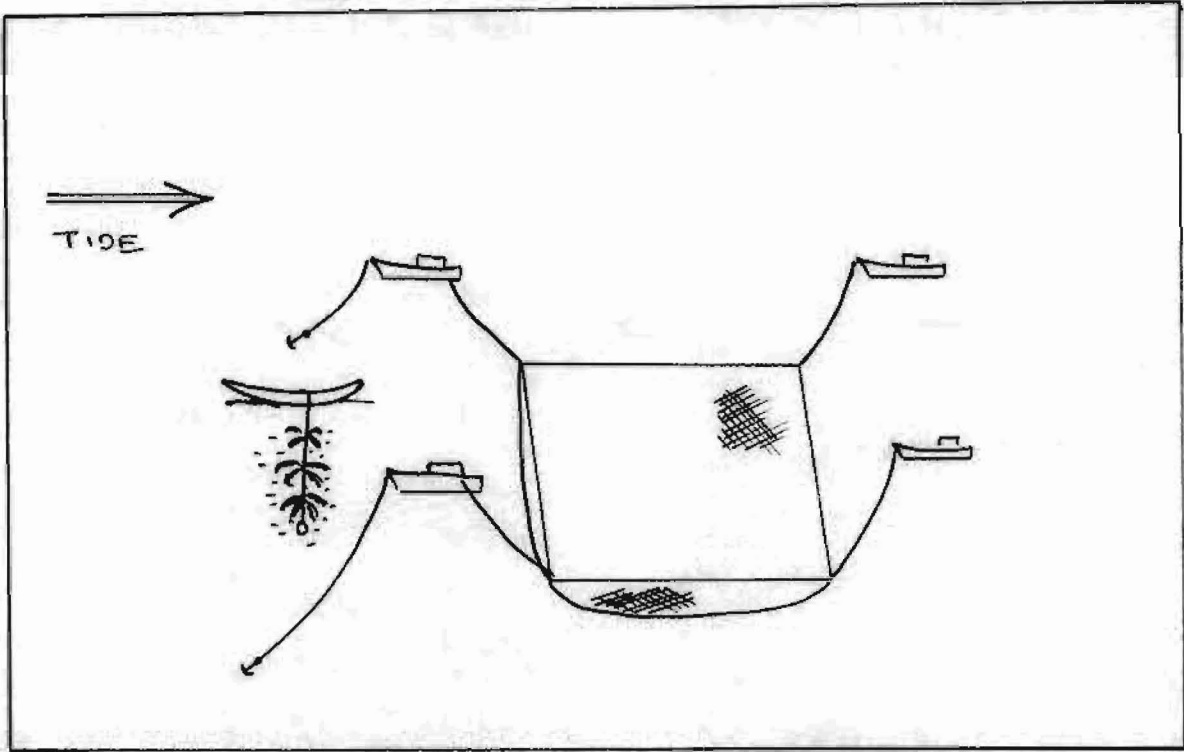

FIG 6.0 SETTING THE LIFT NET.

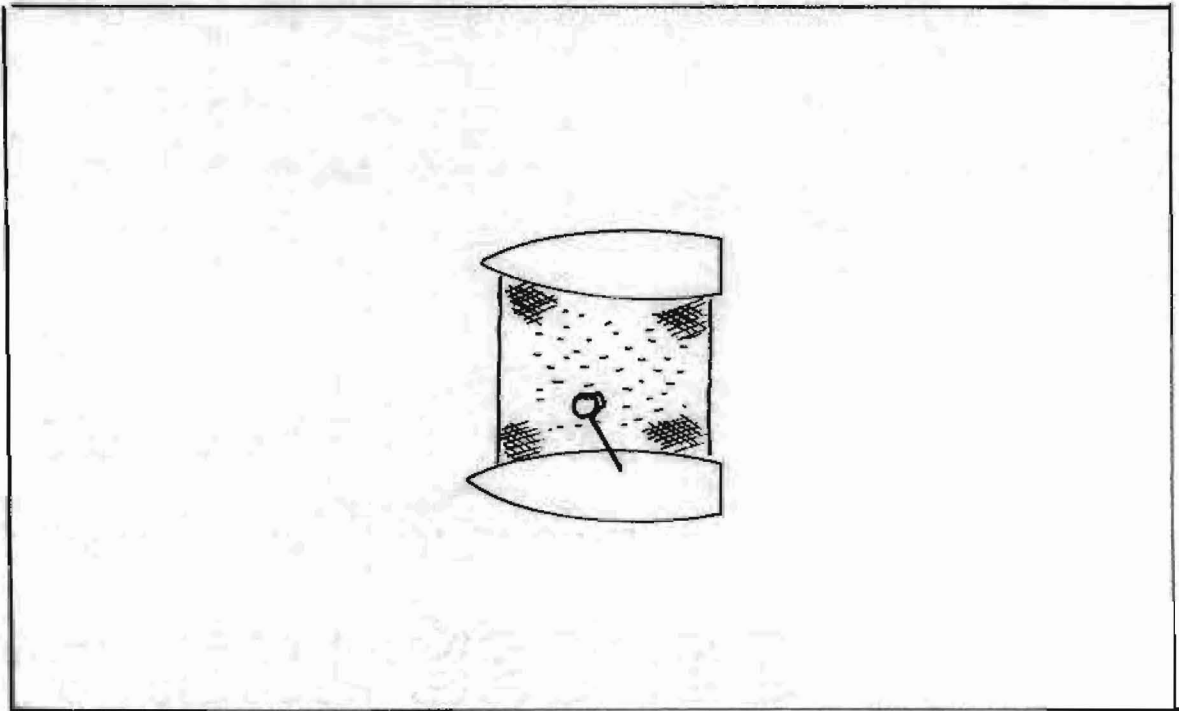

FIG 6.1 HANDLING THE CATCH.

The other three vessels and the diver go to another area to inspect other lure lines. The operation is then repeated.

In the evening, the functions of the lure lines are replaced by the light buoys much like the operation of the purse seines.

This method of fishing is slowly falling into disuse, as it is no more economically feasible. Pelagic species are now mostly caught by purse seines or strike net.¹

¹These are encircling gillnets. It is set by encircling a school of fish. The vessel and crew creates a lot of noise by using large plungers to scare the fish. When the scared fish scuttle away they are gilled in the net. The net is then hauled similar to a gillnet.

A RIGHT MADE
WITH ROPE
FOR HANDLING.

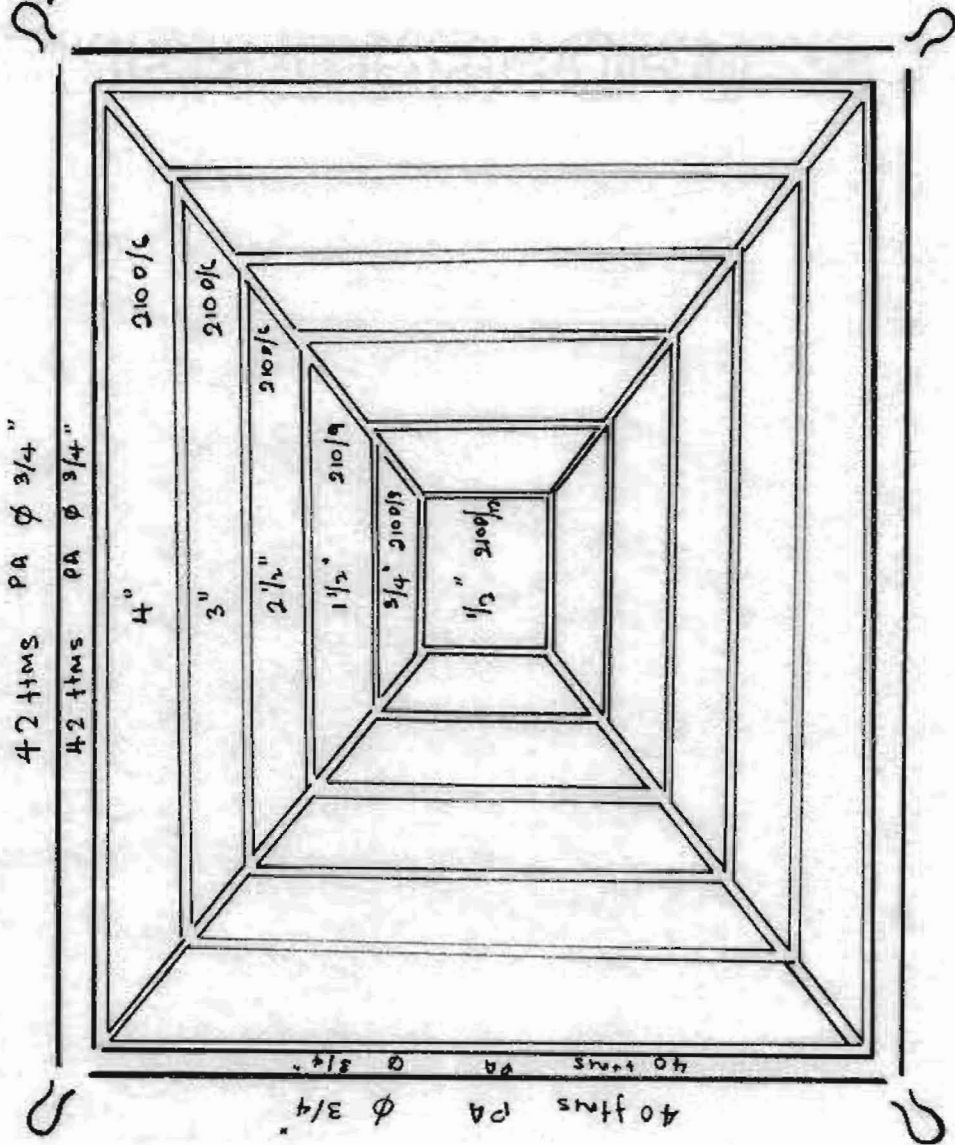

PLAN 6.0 THE LIFT NET.

CHAPTER 7

TRAPS

Malaysia and its vicinity are probably best known around the world for its large traps known as fishing stakes. The trap fishery in Malaysia consists of two distinct components; i.e. the fishing stakes and portable traps (flow pots). These groups of gears landed a total of 8857 in M. tons of fish in 1978. The fishing stakes landed 4,363 M. tons while 4474 M. tons were landed by the portable fish pots.

In the east coast the primary trap used is the portable trap. Of the 413 units operated in the country, 333 were operated in the east coast. In the west coast the more popular gear is the fishing stake. Two hundred seventeen of the 319 fishing stakes are operated in the west coast. The reason for this distinct special preference may be attributed to the more severe weather conditions of the open sea conditions in the east coast which prohibit the maintenance of the stakes through the monsoon season.

7.1. Principles

Basically the catching principle of traps involves guiding the fish into a situation whereby they find themselves unable to escape; the fisherman then hauls his traps and empties the catch.

7.2. Red Fish Pot

Many types of fish pots are operated in Malaysia. They range from heart-shaped pots (bubu jantung) to long cylindrical pots for crabs (enjab hetam). The method to be described is the most popular pot named Red Fish Pot (bubu ikan merah).

Design and construction:

The Red Fish Pot is 6 ft long by 5 ft wide and 4 ft high. It is semi-cylindrical in shape. The bottom frames are made of wood while the top (curved) frames are either made of rattan or bamboo. The whole structure is then encased in 2" chicken wire mesh. On one side of the net is the nonreturn entrance designed to allow fish to enter but not exit. The bottom of the trap contains a door for collection of fish. Figure 7.0 illustrates the plan of the fish pot.

7.2.1. Operation

These pots are operated near coral reefs both close to shore as well as in the open sea near shoals and coral reefs. The traps may be set singularly or on trawls with 10-15 pots per trawl.

In the normal mode of operation the pots are already set in several locations near coral reefs. The fisherman then goes out to his traps and collects the catch. Spare pots are carried aboard to replace damaged or lost ones.

Hauling

Figure 7.1 illustrates the setting of pots in a singular or trawl mode. The vessel approaches the marker buoy slowly keeping it on the starboard bow of the vessel. A grapnel or boat hook is used to pick up the buoy. The float rope is run on the roller to the warping head and hauling commences.

With singular pots, the hauling operation is fairly simple. With trawls the boat must be kept with the tide on the starboard bow so as not to override the lines.

Once the pots surface they are taken aboard and contents emptied by means of a hook through the door at the bottom of the trap. Depending upon the catch, the pots may be set in the same area or at another location nearby.

Should it be necessary to move the pots, they are stacked properly on deck. The vessel steams to a new location and sets the gear again.

Trap vessels working 80-120 miles away from shore, stay at sea for 5-7 days visiting the various pots twice before returning. Normally one fishing unit operates anything from 100-150 pots. Fish pots produce good quality commercial fish such as groupers, red snappers, white snappers, rays, sharks, etc. These are iced and stored in the hold for the return leg.

7.2.2. Share system

The boat owner does not have any share from the gross catch of the vessel. His revenue comes from taking all

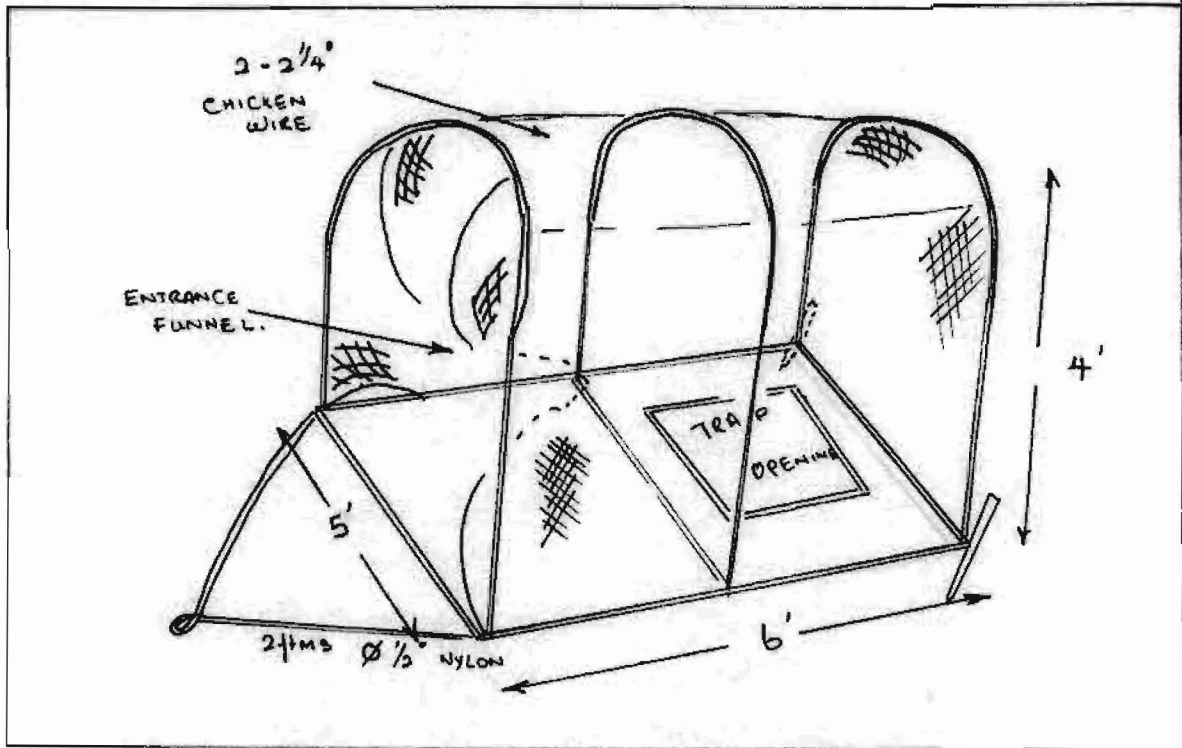

FIG. 7.0 THE RED FISH TRAP.

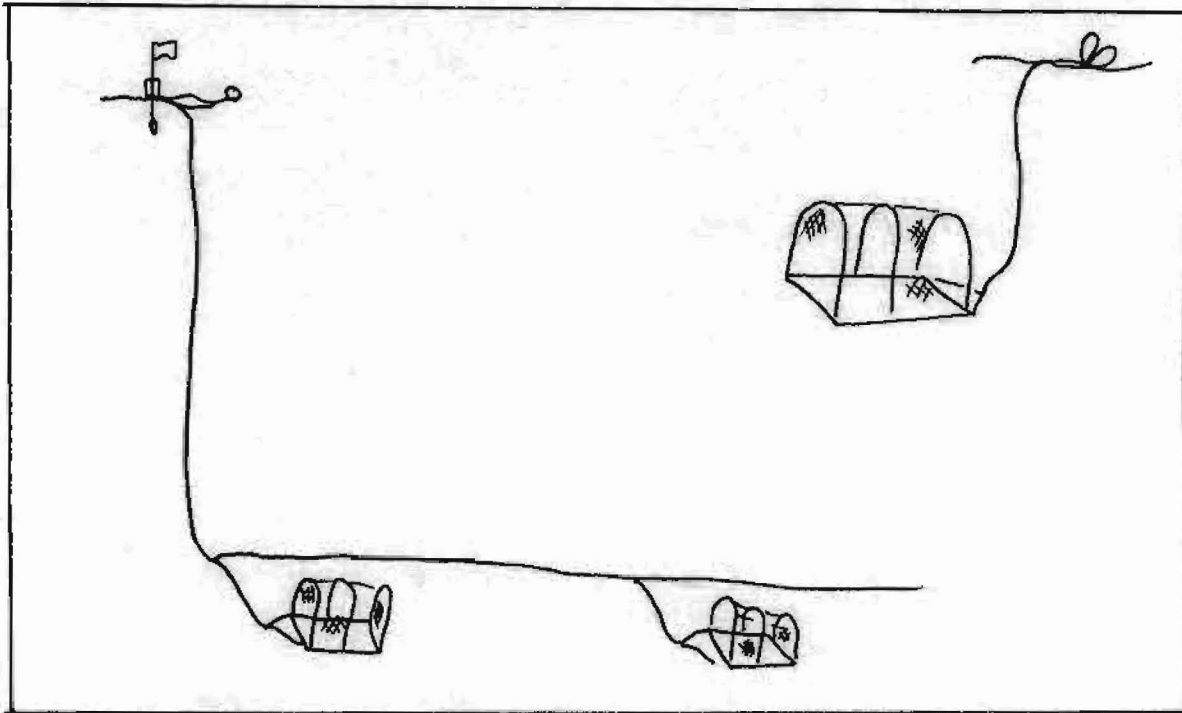

FIG 7.1 SETTING THE TRAPS

the fish at a low predetermined rate and selling it at market value.

From the total revenue all running costs are deducted to obtain a net revenue. This net revenue is then divided into shares as follows:

Skipper - 1-1/2 shares

Engine driver - 1-1/2 shares

3 Crew members - 1 share each

7.3. Fishing Stakes

These are large fish traps constructed of wood and placed in waters close to shore. Most fishing stakes are constructed in water between 6-18 fathoms deep. Figure 7.2 illustrates the construction of a fishing stake (kelong). The trap is placed facing shallow water. This is necessary because when fish meets the leader it turns towards deeper waters and thus into the trap enclosure.

7.3.1. Dimension of the fishing stake:

There are no hard and fast rules about the dimensions of the gear. In most cases the area and financial ability of the owner determine the size of the gear. Generally, however, the gear is 500-600 ft long. The leader is 500 ft. long and wing guides 30-50 ft long. The platform is 70x52 ft.

A hut is built on the side of the fish enclosure. This hut acts as shelter for the fishermen as well as the sorting and processing area for the fish.

7.3.2. Net:

The net is made of nylon with larger polyethylene borders. Mesh sizes are 1/4" at the center progressively getting larger towards the sides. The net is then enclosed by a 1-3/4" diameter metal frame. Construction of plan of the net is appended in Plan 7.0.

7.3.3. Operation:

The kelong is operated throughout the year. Seasonal abundance of fish species affects the catch of the net. Throughout a day 6-8 hauls are done.

Shooting the net:

The net is shot by releasing the winch and the net settles on the sea bottom. Older traps use hand operated rollers illustrated in Figure 7.3. Most of the new traps are hauled by means of a simple winch operated by 2-3 HP diesels. The shooting of the gear takes about 3-4 minutes.

Hauling:

After 3-4 hours depending on the season, the net is hauled. The weight line is then hauled. This is followed by hauling the support ropes that divide the net in four sections.

A long-handled scoop net is used to scoop the fish into baskets placed on the platform. The gear is then reset by reversing the hauling operation.

Types of fish caught include: anchovies, herring, pomfret, snappers, and trash fish.

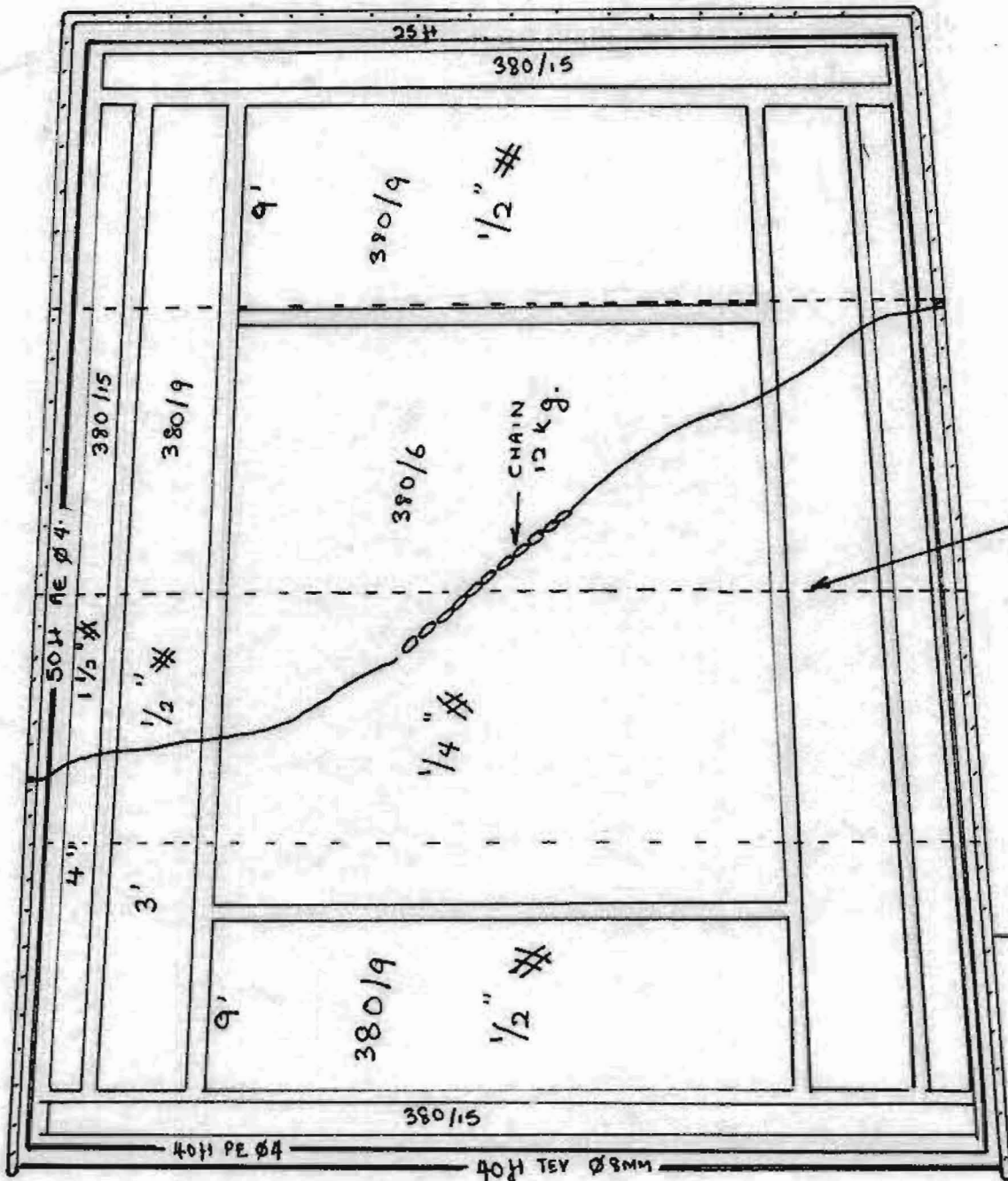
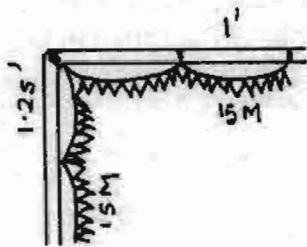

PLAN 7-0 THE FISHING STAKE NET.

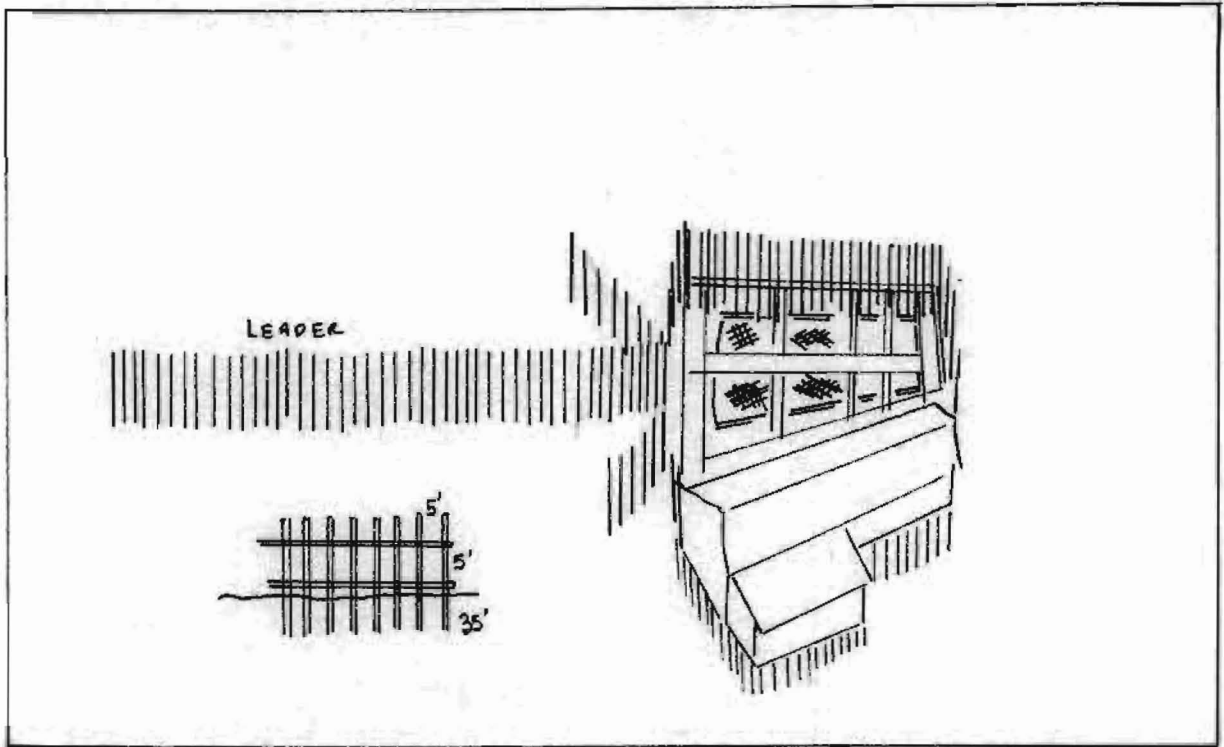

THE FISHING STAKE - KELONG

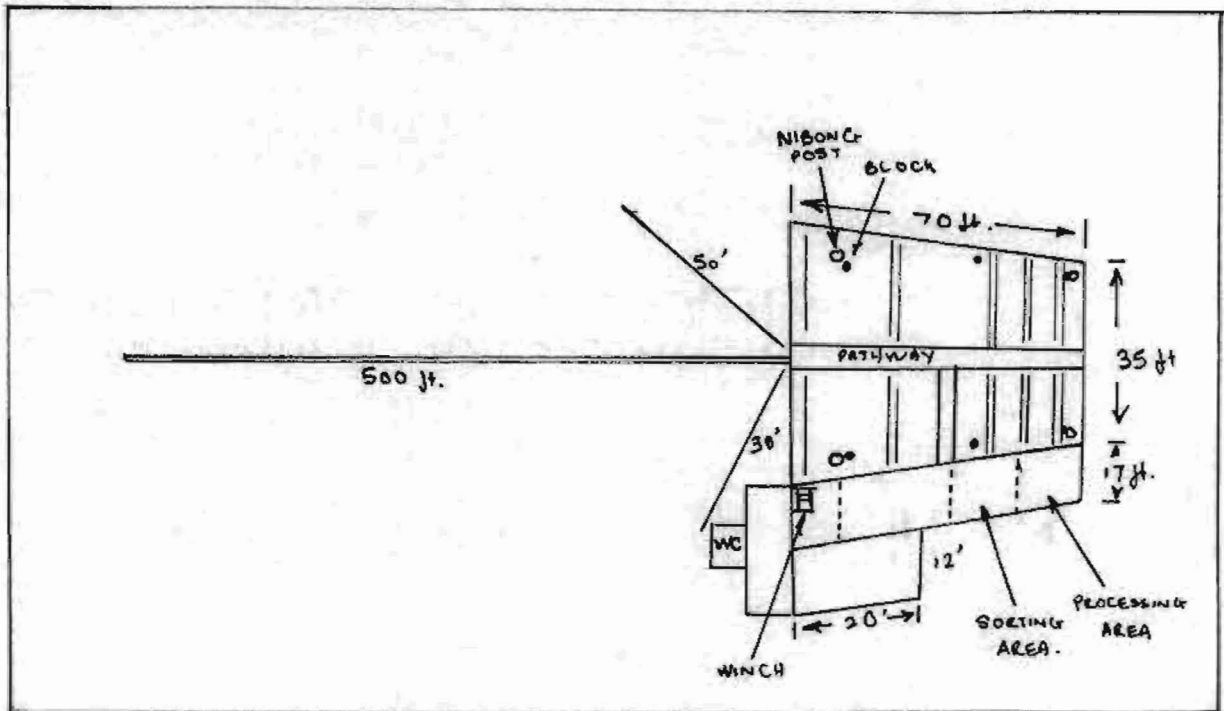

FIG 7.2 THE FISHING STAKE - PLAN

In the evening, two 100-watt lights are placed 3-4 feet above the water in the enclosure. This acts as a fish attracting mechanism, as well as a warning device to indicate the presence of kelong to ensure navigational safety.

7.3.4. Processing:

The catch is then sorted to different grades, I, II, and III in accordance with normal marketing procedures, and stored in iced styroform boxes. Anchovies, however, are first processed and will eventually be dried out and sold as dried fish. Processing of the anchovies involves boiling for 3-4 minutes in salted sea water. Ratio of fish is salt 4 lbs to 10 gallons of seawater to 20 lbs of fish.

The catch is brought to the beach every morning at sunrise to the fishing stake owner who will eventually sell it in the market.

7.3.5. Share system:

Fishing stake workers are paid monthly wages of \$200/month. Food on board is provided by the owners. All costs are borne by the owner who takes all the catch.

7.4. Jermal

Another form of fishing stakes operated primarily in the west coast of Peninsula Malaysia are called Jermal. These gears are not strictly traps but more bagnets in their principles of operation. However, as these gears are built using stakes very much like the Kelong, they are classified as fishing stakes and grouped under the classification of fishing traps.

Principle of operation:

These gears are found primarily in areas of large tidal differences. The nets then filter the water to collect fish and other marine organisms in a large conical bag.

7.4.1. Construction:

The Jermal is constructed of fishing stakes placed on the sea bed. On first observation it looks very much like the kelong. Closer observation, however, reveals that these gears do not have the leaders. Instead long guides are used to channel the water below the platform which contains the net to filter the fish. Figure 7.3 illustrates an elevation view of a jermal. The mouth of the gear is placed facing the direction of the ebb tide. This is the normal orientation of the gear as fishermen believe that the flow of the ebb tide is generally faster than that of the rising tide. Consequently, more fish are caught with this orientation.

7.4.2. Net:

The net consists of 2-3 pieces of flat net some 19x22 ft. This net acts as a step towards the conical bag. The flat net is made of interwoven rattan and is illustrated in Figure 7.4. Of late the materials used for the flat net are replaced with one inch plastic strips. This change is necessitated by the high cost of rattan as a result of its shortage. The expected lifespan of the rattan net is

approximately four months while the synthetic replacement lasts approximately three years.

The plan for the conical bag at the end of the gear is shown in Plan 7.1. The conical bag is made with "MOJI" netting. Moji nets are synthetic staple fibre nets and treated to give the required firmness and protection. Moji nets possess small square meshes and can be obtained with 100-200 meshes per foot of netting.

The flat conical net is then folded and its ends seamed to give it the necessary conical shape.

7.4.3. Operations:

Realizing the catching principles of the net, this operation is very much affected by the tide. The gear is operated some 20 days every month. During neap tides the gear is not operated and the people on the Jermal take their much needed leave.

At the height of the high tide, the net is lowered into the water. This is done by lowering a long pole that holds the mouth of the flat net. Other parts of the net are handled by ropes and pulleys. Simultaneously, the conical bag is also set. The cod end of the net is tied to a lazy line that is attached to the platform. To empty the cod end is simply done by hauling the lazy line. The cod end is emptied every hour. If fishing is good then hauling is done more often. The species caught are similar to those caught by the Kelong.

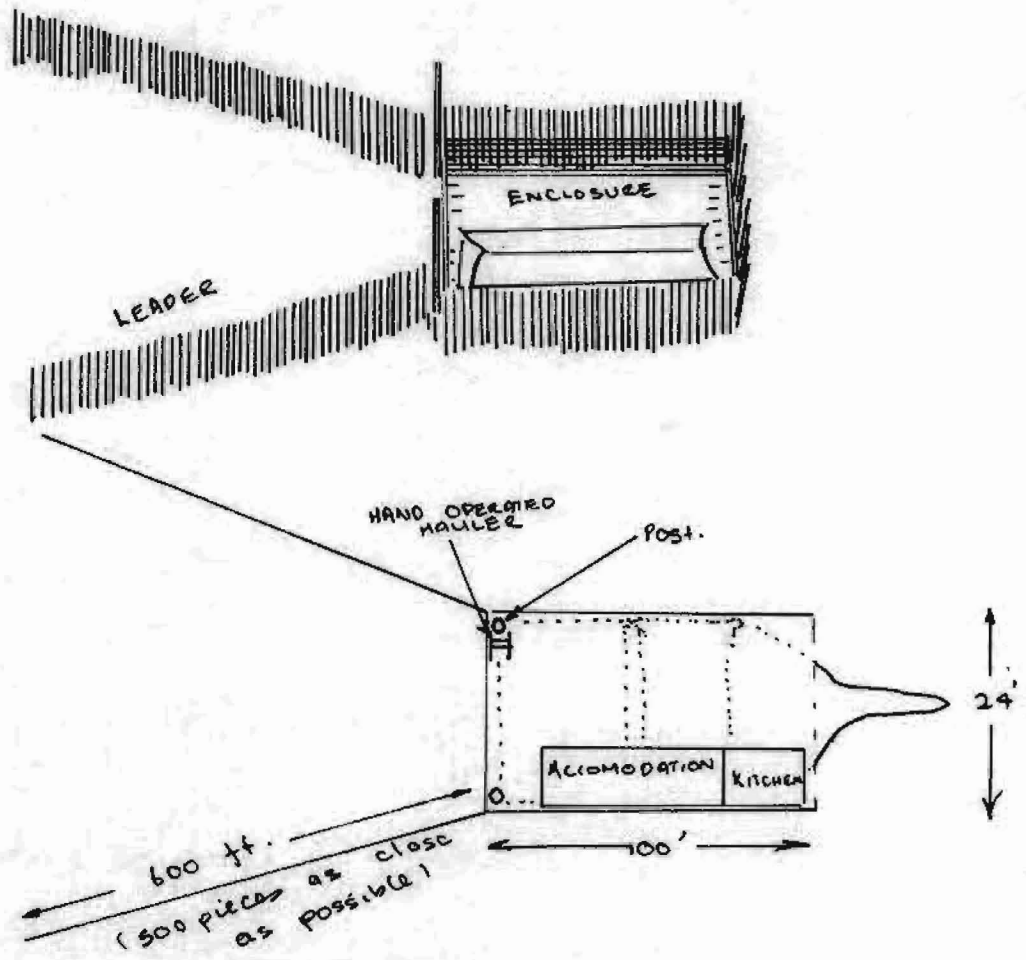

FIG 7.3 THE JERMAL - PLAN.

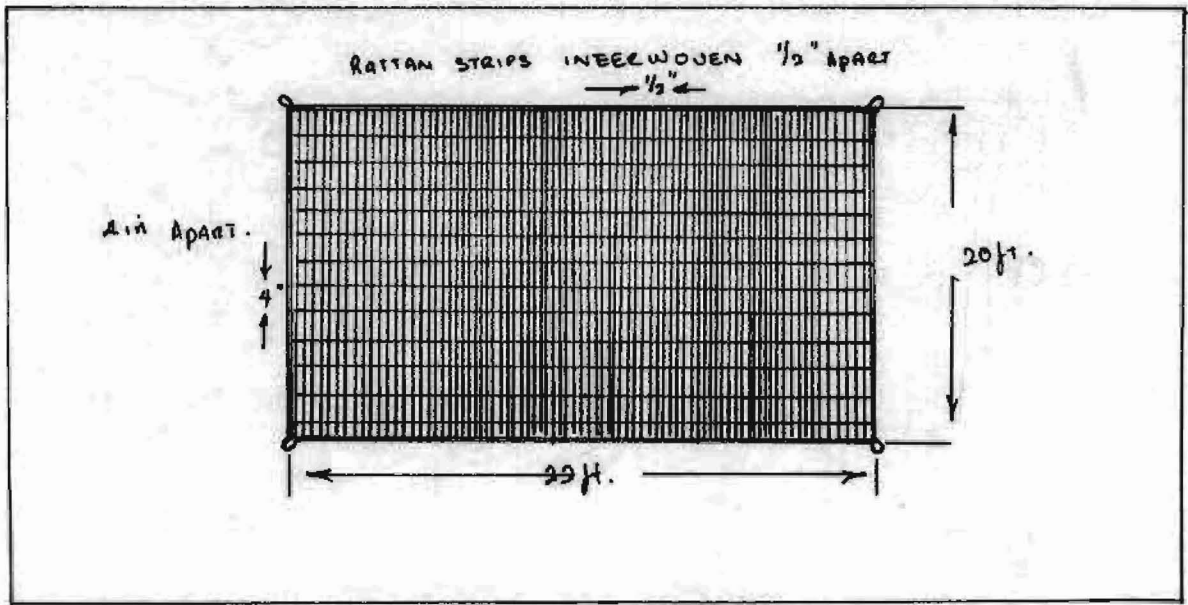
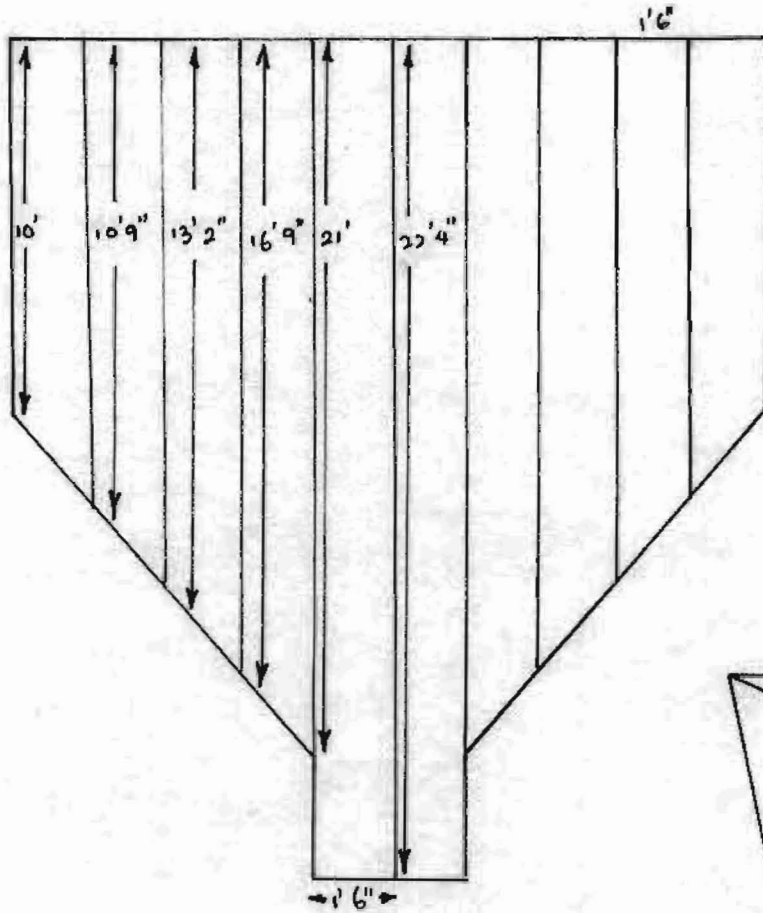

FIG 7.4 FLAT NET FOR THE JERMAL

Similarly anchovies landed are boiled and dried on board the Jermal. At the lowest tide before the water rises again the whole net is raised above the water line until the next high tide before setting is done again.

7.4.4. Share system:

The share system on a Jermal is a combination of fixed wages and shares. The fishermen receive a fixed \$40 wage for every 10 days aboard the Jermal. The net revenue is then divided into 60% for the owner and 40% for the workers to be shared equally. A jermal normally has 2-3 workers aboard.



MOSI NET
SARAN NYLON

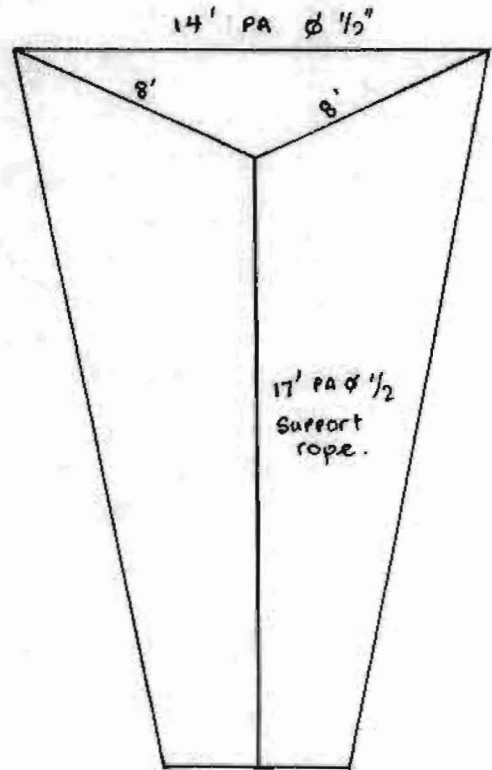

PLAN 7.1 THE JERMAL.

CHAPTER 8

HOOK AND LINE

Hook and line fishing is one of the oldest methods of fishing employed. It includes handlines and long lines. Almost every fishing vessel carries simple hand lines used in-between operations as a means of relaxation or to pass the time between shooting and hauling the gear - for instance in the gill net operations.

8.1. Principles

The catching principle of hook and line fishery is to bait fishing hooks which attract fish to them. Once the hook is taken it attaches itself into the mouth of the fish. The barb in the fish hook prevents the fish from escaping from the hook.

8.2. Hand Lines

A large variety of hand lines are used in the fishery. The large number of designs reflect the various concepts perceived by the fishermen as effective to catch the fish aimed for. Figure 8.1 illustrates some of the common hand lines operated.

Figure 8.1A shows a handline with a flexible balance which is said to compensate for the sudden pull of the fish.

Figure 8.1B. This type of construction is often attached to 2-3 hooks to increase the catch probability.

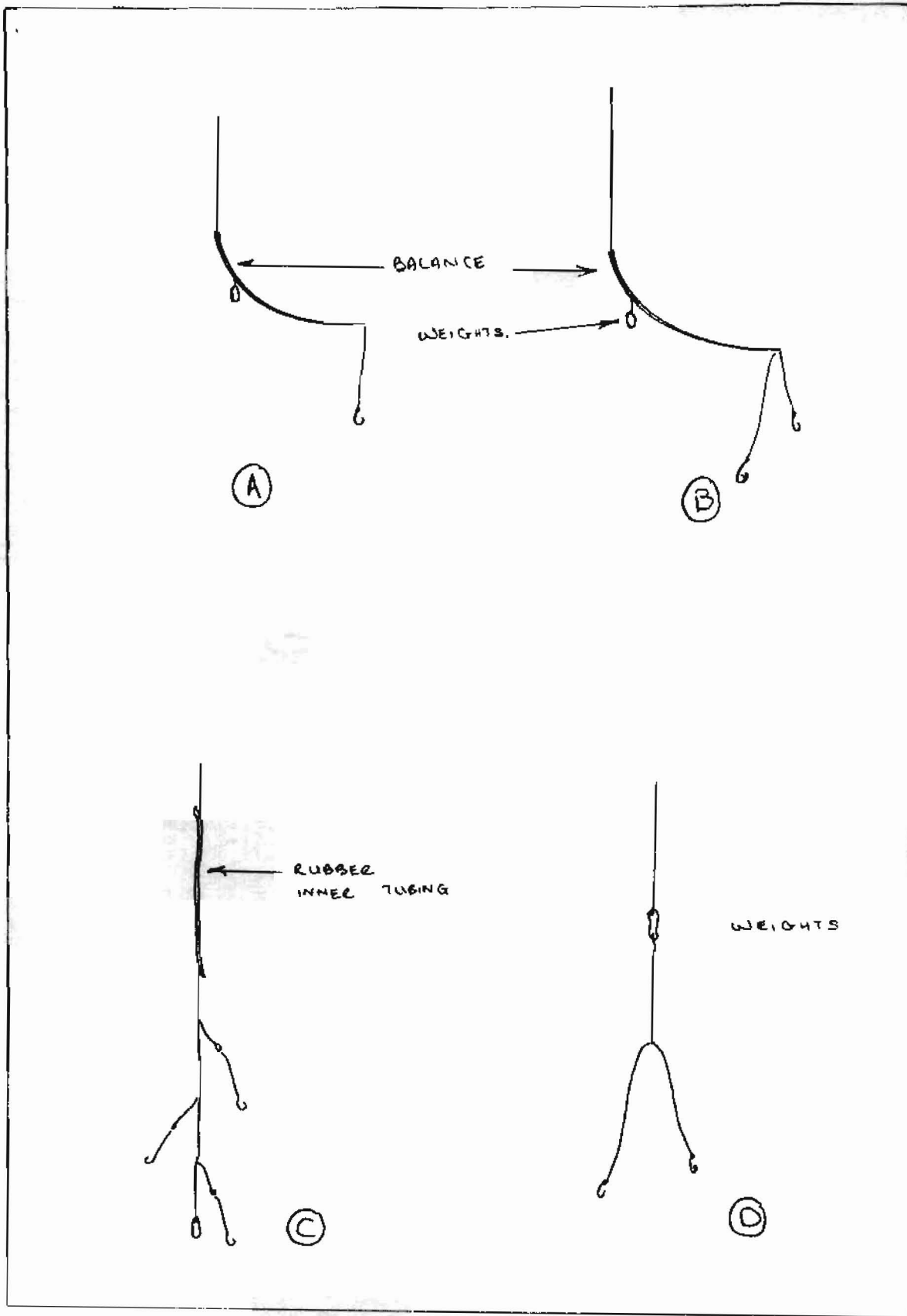

FIG 8.1 SOME COMMON HAND LINE CONSTRUCTION.

Figure 8.1C represents a construction that incorporates a shock absorber made of tire inner tubes. The hooks are attached to the main line with a swivel arrangement to take out any spin.

Figure 8.1D. This is the most common construction. It consists of hooks on a weighted line.

8.3. Commercial Operation

While most hand lines are operated as a supplementary device, some handline fishing is done as the main fishing activity. One such operation is mackerel handlining.

8.3.1. The Gear:

The gear is simply a handline with 15-20 hooks as shown in Figure 8.2.

This gear is made of monofilament lines. The distance 2Y is made less than X to ensure that the hooks do not get tangled with one another. This gear is not baited but uses small bits of multicolored nylon fibers attached to the hooks as lures. This is illustrated in Figure 8.3.

8.3.2. Operation:

During the mackerel season, hand line fishermen go out to the lure lines to fish for mackerel. It is not uncommon during good periods that all the hooks will catch a fish in one cast. A more important gear in this group of fishing gear is the longline.

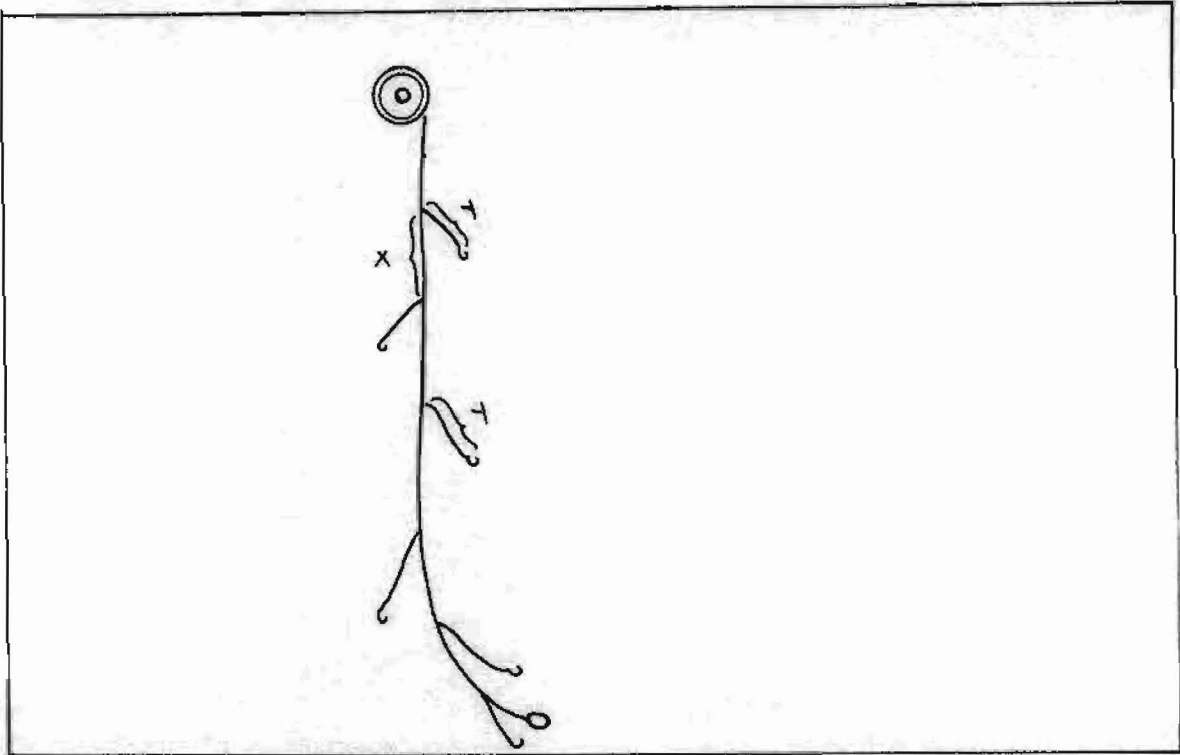

FIG. 8.2 MACKEREL HANDLINE

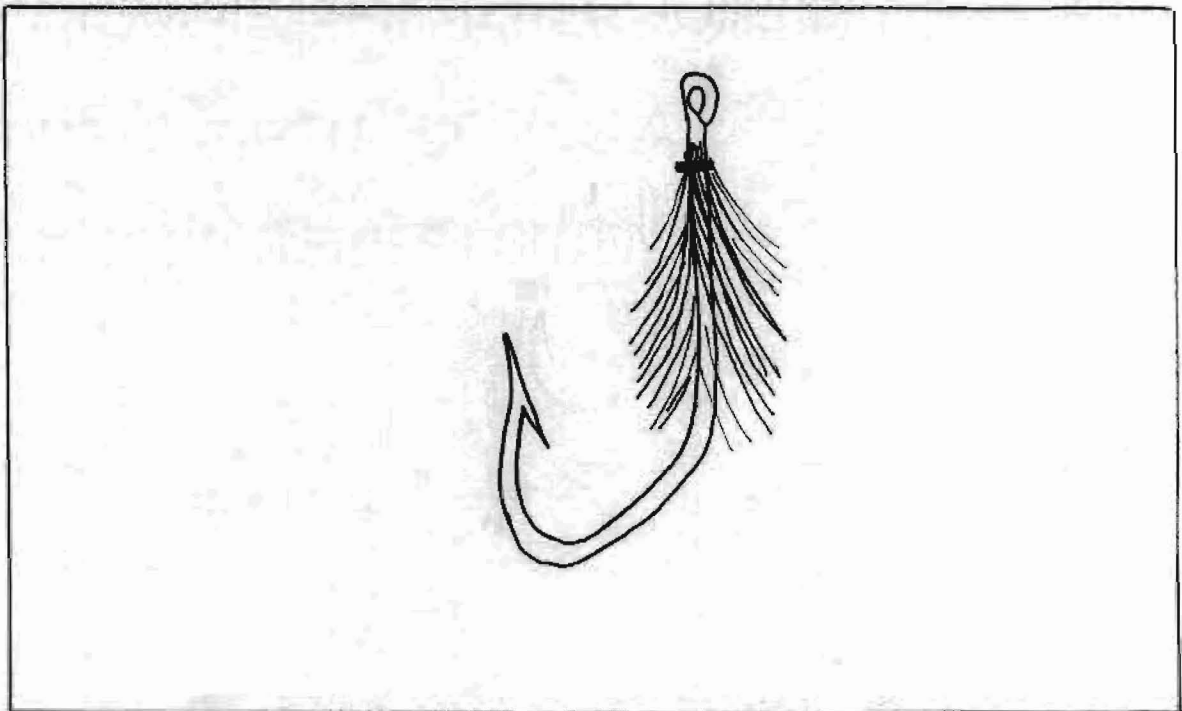

FIG. 8.3 LURES FOR MACKEREL HANDLINE

8.4. Longlines

Termed rawai locally, it is operated in inshore and offshore areas. Inshore longlines are operated on a daily basis while the offshore vessels operate from 5-7 days at sea. Longlines are a succession of small lines bearing hooks attached to a main line. These hooks are baited to attract fish to take the bait.

8.4.1. The Gear:

Longlines are 300-600 fathoms long each bearing some 300 hooks each. Constructional design of a longline is given in Plan 8.0.

The main lines are made of 3mm hard laid saran rope. Branch lines are a combination of 2-1/2mm saran rope and monofilament twine. The float rope is normally made of nylon.

When fishing in soft muddy bottom extra floats are attached every 100 fathoms to ensure that the lines are not carried under the mud. Each 300-600 fathom longlines are coiled in a basket in preparation for the fishing operation. In one set 2-4 baskets are used.

8.4.2. Operation:

On arrival at the fishing grounds the longlines are baited with cut trash fish and squids. Components of the gear are then attached and the vessel is ready to set the lines.

The gear is then set perpendicular to the tide to ensure that the branch lines/sudlines flow clear of the

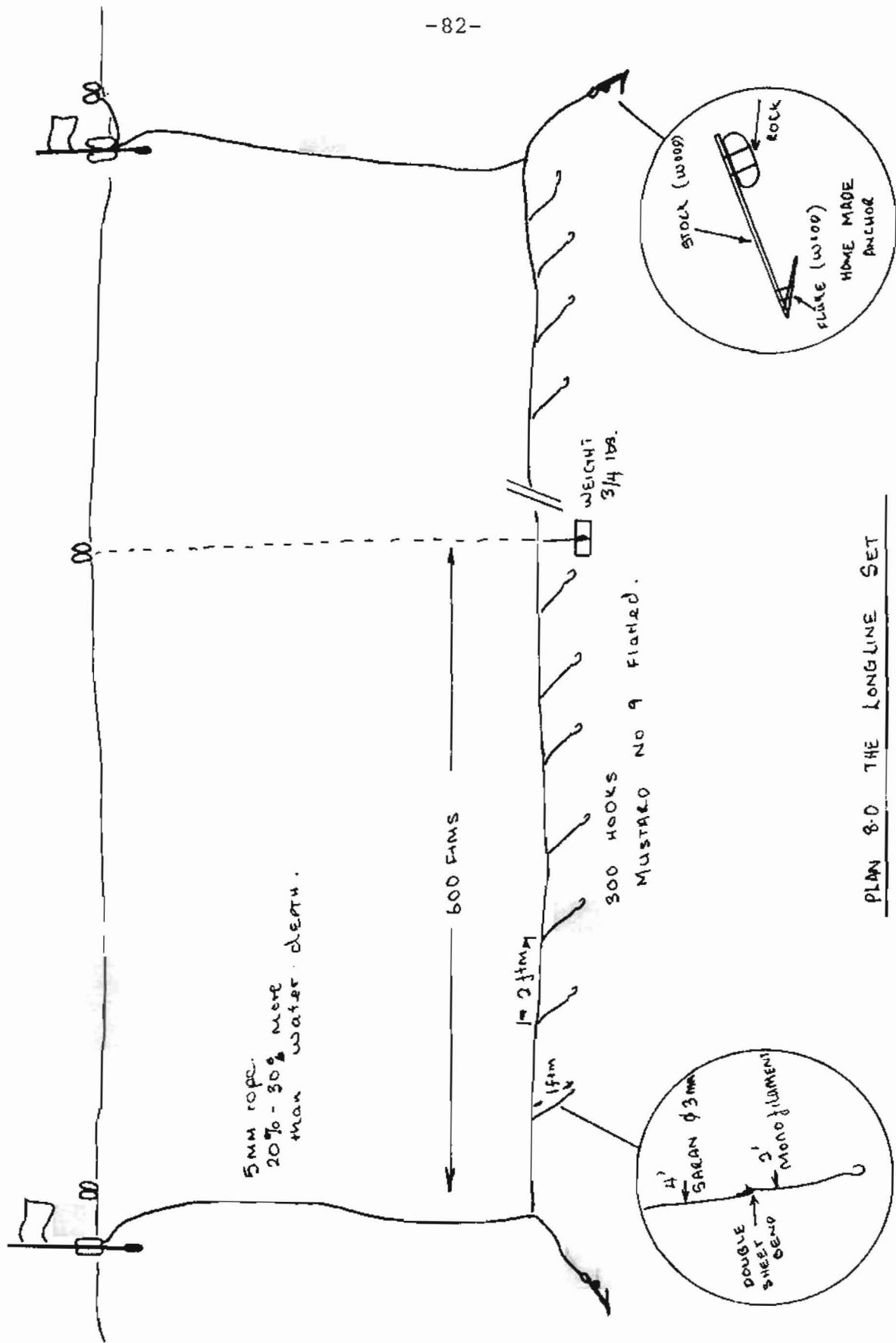

PLAN 8-D THE LONGLINE SET

main line. For two baskets of 600 fathom longlines the setting time is approximately one hour.

After setting the gear the vessel either anchors or is allowed to drift for 2-3 hours before hauling begins.

Hauling:

The gear is hauled manually. One man hauls the gear, cleans the bait and retrieves the fish. The other fisherman coils the lines in the basket. Meanwhile the skipper handles the vessel to ensure that the longlines are approximately 2 points on the starboard beam. Hauling may be done with the tide or against the tide.

Once the gear is retrieved the vessel steams away to another area to reset the gear. In the evening a lighted buoy replaces the flag buoys.

Longlines are used primarily for high quality demersal fish such as: red snappers, groupers, breams, barracudas, sharks, rays, ribbon fish, triggerfish. The catch is then sorted, washed and stored in ice.

8.4.3. Share system:

Share system employed in the longline fishery is a kind of pseudo lay system. The gross catch is divided equally among all the crew members. This gross revenue, however, is determined by the boat owner who takes all the fish at a price much lower than the market value. In this system however, all costs are borne by the owner of the vessel. During periods of poor fishing the boat owner advances cash to the fishermen. This loan is repaid over periods of better

catches. This system of wages tends to tie the fishermen to the boat owner through his debts.

CHAPTER 9

BAG NETS

The bag nets are represented by such gears as gombang, pompang, ambai and togok. These gears are important for the capture of shrimps, especially for a krill-like organism, *Acetes* spp. In 1978 the landings by the bag net group were 26,916 M. tons. Bag nets are found primarily in the west coast of Peninsula Malaysia.

9.1. Principles

These nets are located in areas of large differences in tide. Fish and other organisms are filtered by a conical bag. The large difference in tide ensures a large volume of water filtered. By this necessity, these gears are not operated during periods of neap tide.

9.2. The Net

The gombang net looks like a trawl net. The main difference is that the wing is short. The first three panels and the rod ends are made in one piece. The head rope and footrope are 75 ft. long. The net is made of polyethylene netting while the last three panels are made of saran netting. The end of the wings are attached to a 18" \emptyset diameter steel ring. These rings are used to attach the net to stakes embedded into the seabed to hold the net. Plan 9.0 illustrates a gombang net.

9.3. Operation

The Gombang nets are set by fixing them onto fishing stakes embedded into the seabed. Unlike the trap, Kelong, only two stakes are used to every net. Gombangs are set in a row of 10-16 nets.

An old boat is anchored near to the set for one fisherman to keep watch over the gear. Figure 9.0 illustrates a Gombang net. The gear is operated for 9-10 days, stopped for 5 days corresponding to period of neap tides, then operated again for 9-10 days. Each fishing period is termed 1 water. During the fishing period the fishermen stay aboard this boat. The net is hauled four times a day during slack tide. This is necessary to make the hauling easier. The owner of the net comes with a tender boat twice a day to assist in the hauling operation and collect the catch.

To haul the gombang the tender boat is used. The float above the head rope is hauled. The moment the net rises it is hauled to get to the cod end which is then washed by dunking it in the water several times and taken aboard into the hold. After releasing the catch into the hold, the cod end is then retied using natural twine placed inside the extension piece and thrown overboard. The idea of putting the cod end inside the extension piece is so that the changing tide catches the net from the opposite direction enabling the gear to catch fish in both ebb and flow situations. This operations takes 5-10 minutes. The vessel then moves to the next net and the hauling begins again.

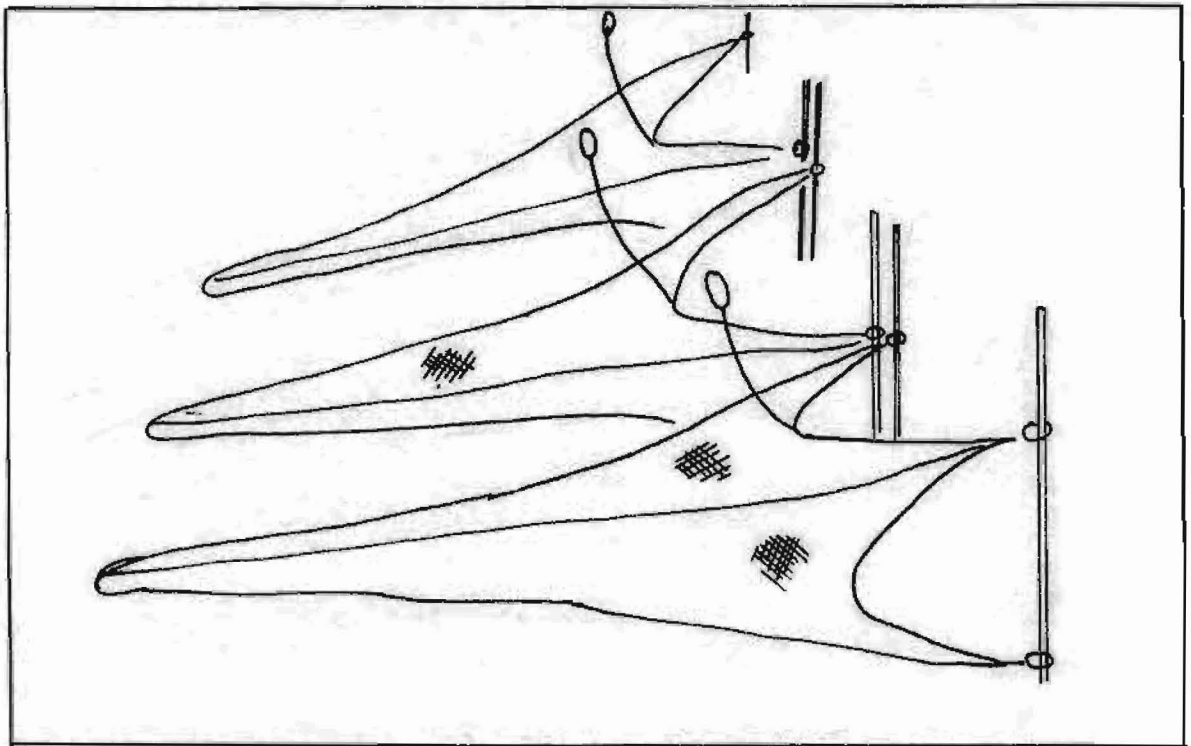
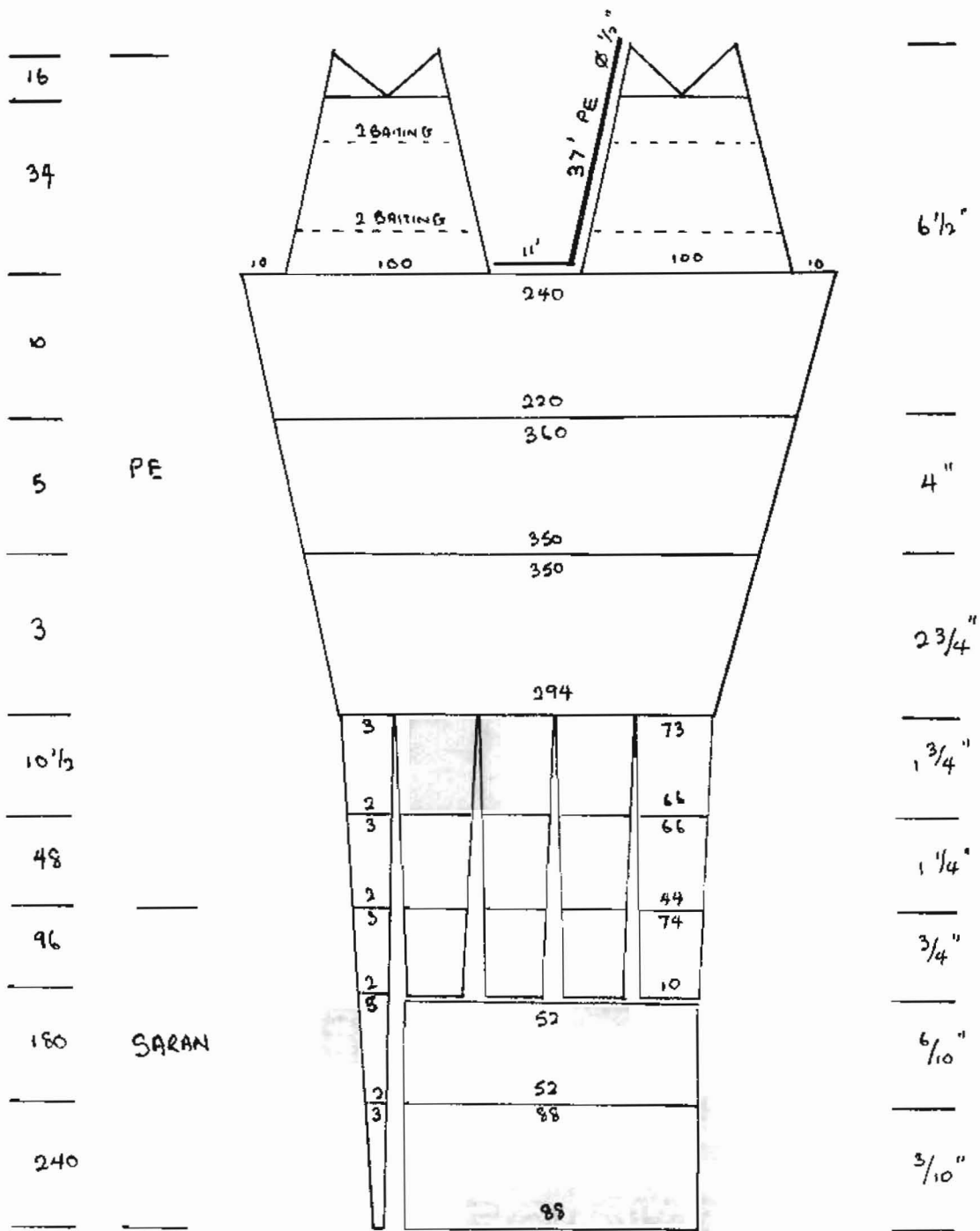

FIG 9.0 THE BAGNET (GOMBANG) SET.

After hauling all the nets the vessel returns to the anchored vessel. The catch is sorted. Fish and shrimps are iced in the holds. The Acetes Spp., a primary ingredient for shrimp paste, is salted and kept in baskets in the hold to be sold to the paste manufacturers. Normally the tender boat then waits for the next tide and performs another operation before returning to base with the catch.

9.4. Share system

The fisherman receives a fixed wage of \$240/month plus food. Shares for jellyfish, which fetches a good price, are divided equally among the owner and crew. All costs are borne by the owner.



PLAN 9.0 BAGNET (GOMBANG)

CHAPTER 10

PUSH NETS

Push nets are operated on the beach for the purpose of catching small krill like shrimp *acetes* spp., shrimp and small fish. While the shrimps are marketable the small fish are used for bait and home consumption. Push net groups account for 963 M.tons of the total catch for 1978.

10.1. The Net

The gear is made of triangular nets fixed on two wooden poles. The net is approximately 15 ft. wide at the mouth and about 11 ft. deep. The wooden poles are attached to make an X. This is illustrated in Figure 10.0. The foot of the pole is fitted with skids to allow the gear to glide over the bottom.

10.2. The Operation

The net is operated against the current taking advantage of the flow to carry *acetes* spp. with it. On arrival at areas of greatest shrimp abundance, the fishermen alight from the boat, lower the net and let the gear slide on the bottom. The net is pushed for 15-20 minutes. While pushing the net the boat is attached to the fishermen.

Before hauling the mouth of the net is closed and the poles are placed on the boat. The cod end is then lifted onto the boat and catch released. This operation is carried on for about 3 hours before the fishermen return to sell the catch. Figure 10.1 illustrates the push net operation.

There are several variations to this gear. A smaller version of the net is operated close to the beach. The floating container is now used to store the catch. These gears are operated during the low tide to allow the fisherman to operate his gear further away from the shore.

In the late 1960s, there was a proliferation of push nets operated by mechanically propelled vessels. This fishing method caused the destruction of natural fish spawning areas and coral bed. As a result of this the fisheries (prohibition of method of fishing) regulations 1971 (P. U. (A) 187 of 1971) was enacted which prohibit the use of such fishing method.

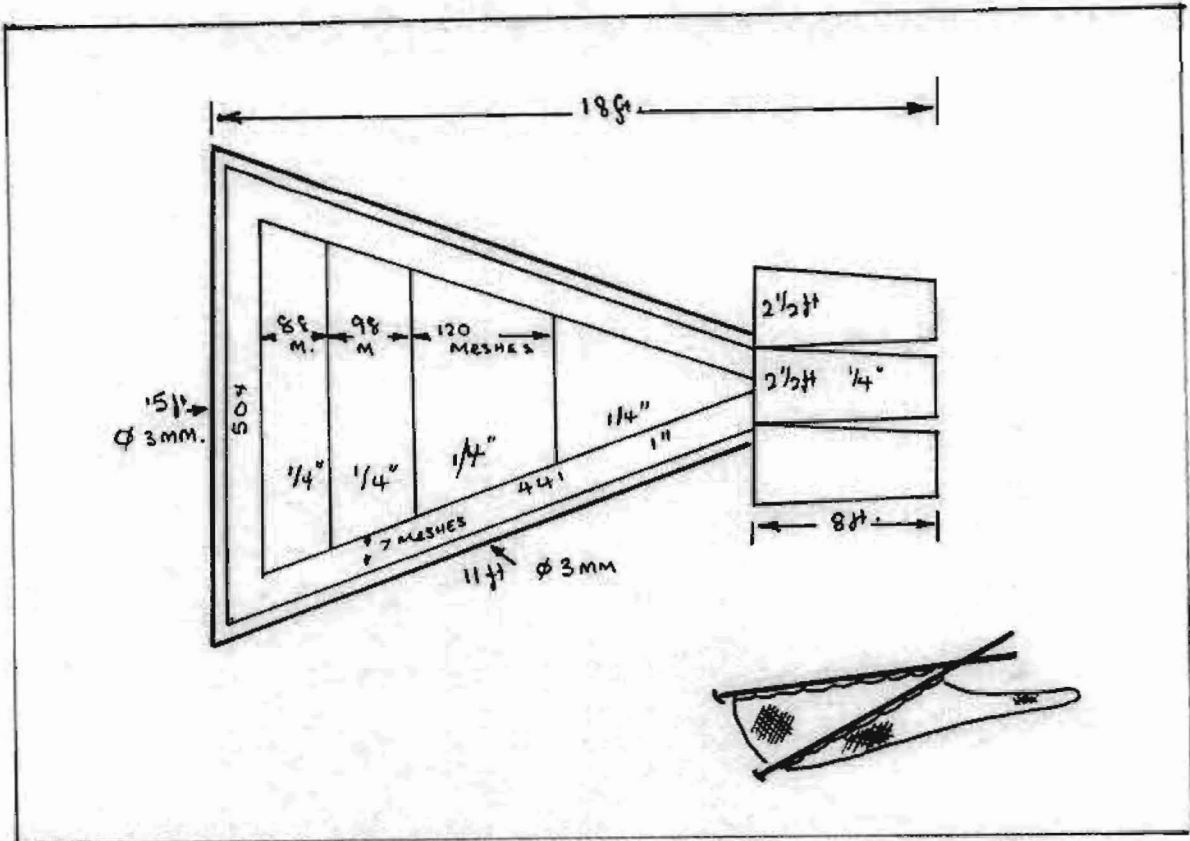

FIG. 10.0 THE PUSH NET

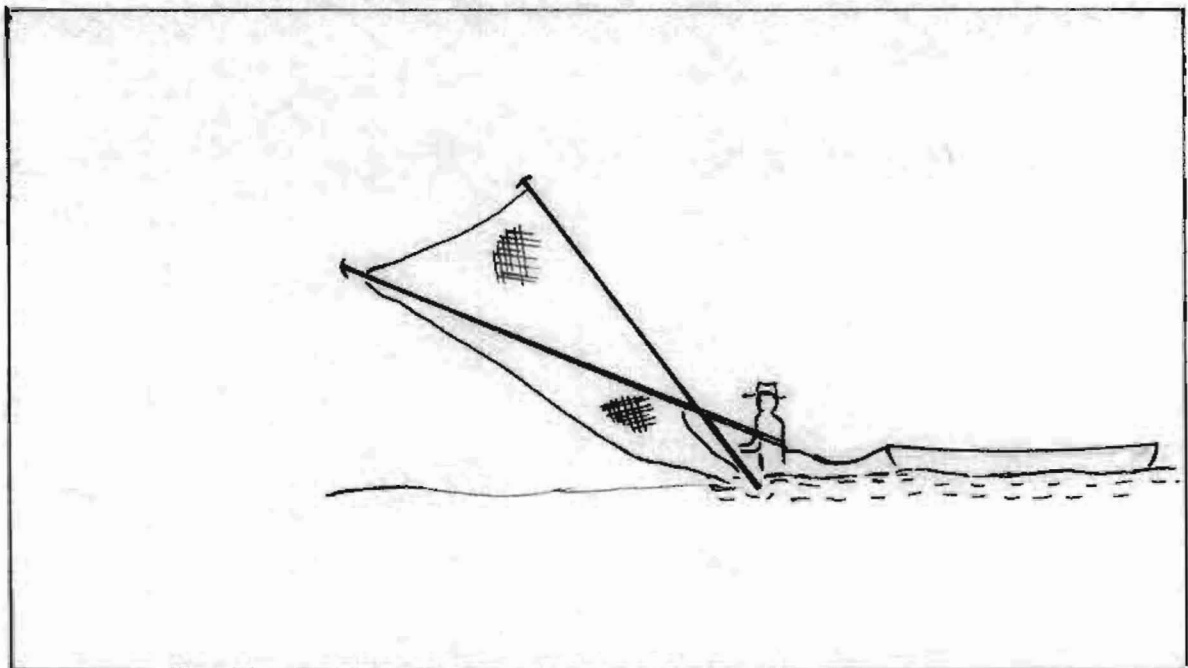

FIG. 10.1 THE PUSH NET OPERATION

CHAPTER 11
BARRIER NETS

Barrier nets are used about 20-30 fathoms from the shore. They are set in areas near mangrove swamps. In 1978 the catch from this gear was 963 M.tons.

11.1. Principles

The gear is set like a gill net in the water during high tide. However, this gear is anchored to the ground by using poles. As the tide recedes fish that are returning to the sea with the tide are gilled and enmeshed in the net.

11.2. The Net

Construction of the net is similar to the gill/net. Each net is 18 fathoms long and 6-1/2 fathoms deep. It is made of 3" monofilament with a polyethylene headrope and footrope. Floats and weight are attached to the headrope and footrope to ensure the nets hang vertically in the water. Plan 11.0 shows a construction plan of the net.

Twenty-eight pieces of net are joined to make the gear. Every two nets are attached to a 1-1/2 fathom long pole. These poles are used to hold the net in position to catch the fish (Figure 11.0).

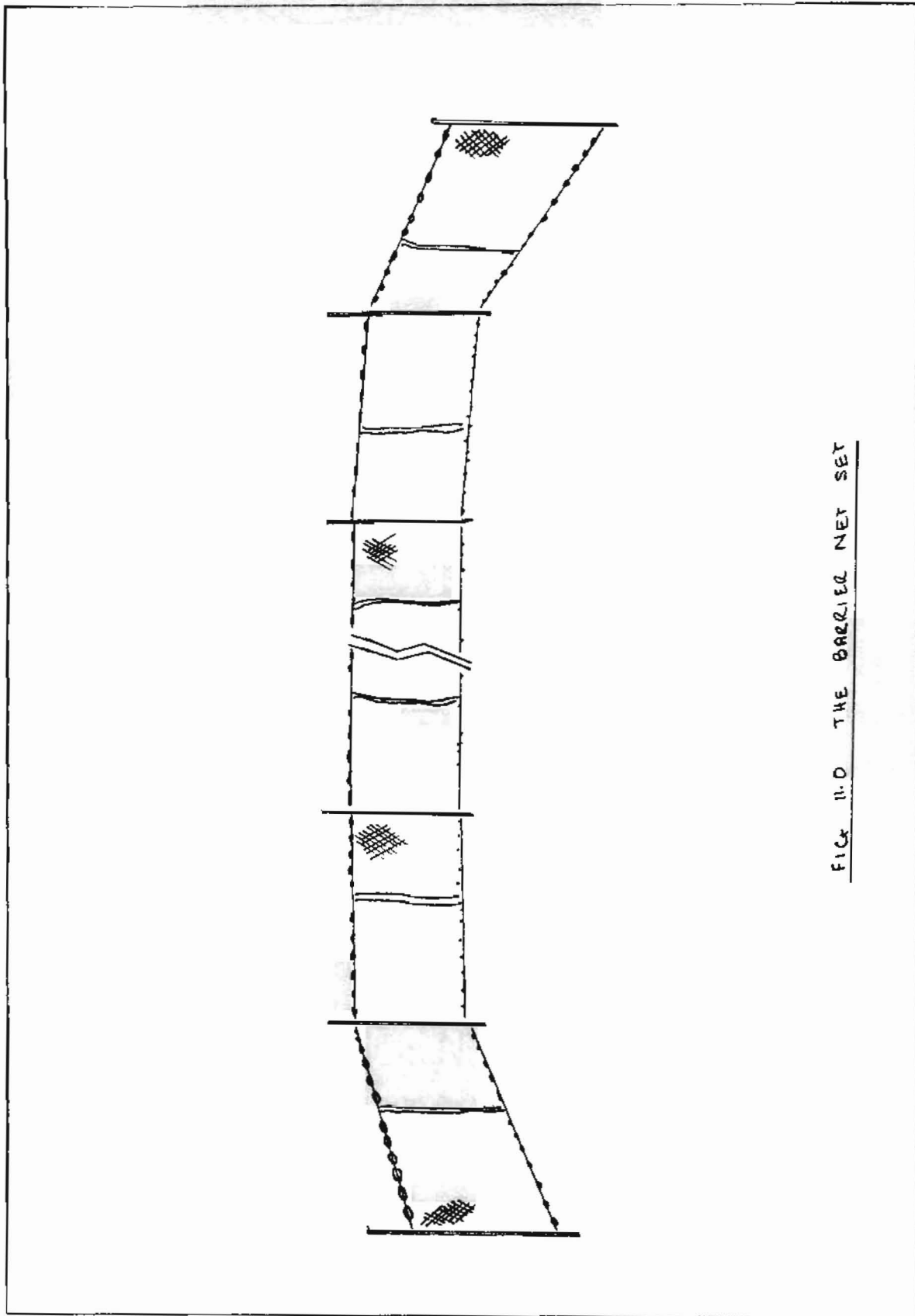

FIG. 11.0 THE BARRED NET SET

11.3. Operation

One or two persons operate the gear. The gear is set during high tide. The nets are attached to the poles which are in turn embedded into the ground. The net is then left in position until the tide recedes. During low tide the vessel returns to collect the catch. This net is left in position for another tidal cycle collecting the fish during the subsequent low tide. During the second operation the gear is hauled and will be set again in a nearby area during the subsequent high tide.

11.4. Catch

Some 30-40 lbs. of fish are caught in one collection. The catch comprises such fish as: tongue sole, jewfish, catfish, and treadfin. As this gear is a one-man or family operation, no share system is used. However, in cases of an operator working for an owner, the catch is divided equally between the operator, boat owner and gear owner.

Rubber floats (3 x 3/4" φ) x 35

18 fms PE φ 5mm.

18 fms PE φ 3mm

600

30

3" #
mono (0.6mm)

19 fms PE φ 3mm

19 fms PE φ 5mm

PB (1.5" x 0.5" φ) x 36

6'

PLAN II-D THE BARRIER NET.

CHAPTER 12

12.0. Shellfish Collection

Shellfish are collected on the beach, and mudflats in a variety of methods. However, the most important gear in this group is the cockle collection. This gear became important only after 1973 with the advent of cockle culture in natural beds.

Cockle culture is now very popular in suitable mud flats in the west coast. In this operation natural cockle spats are collected. These are then sowed into mudflats to grow for 6-8 months before harvesting. Prior to sowing the seeds, the natural grounds are prepared by raking. This operation clears the grounds from sunken wood and other objects. It also rejuvenates the ground by turning the soil to allow nutrients from the lower level to surface.

12.1. Catching Implement

The cockles are collected from the ground by means of a metal rake somewhat similar to a quahog rake. Its dimensions are 38" x 7" x 12" deep. Figure 12.0 illustrates the gear.

12.2. Operation

Collecting the cockles is done during low tide. The rake is attached to the bow of the collecting vessel by

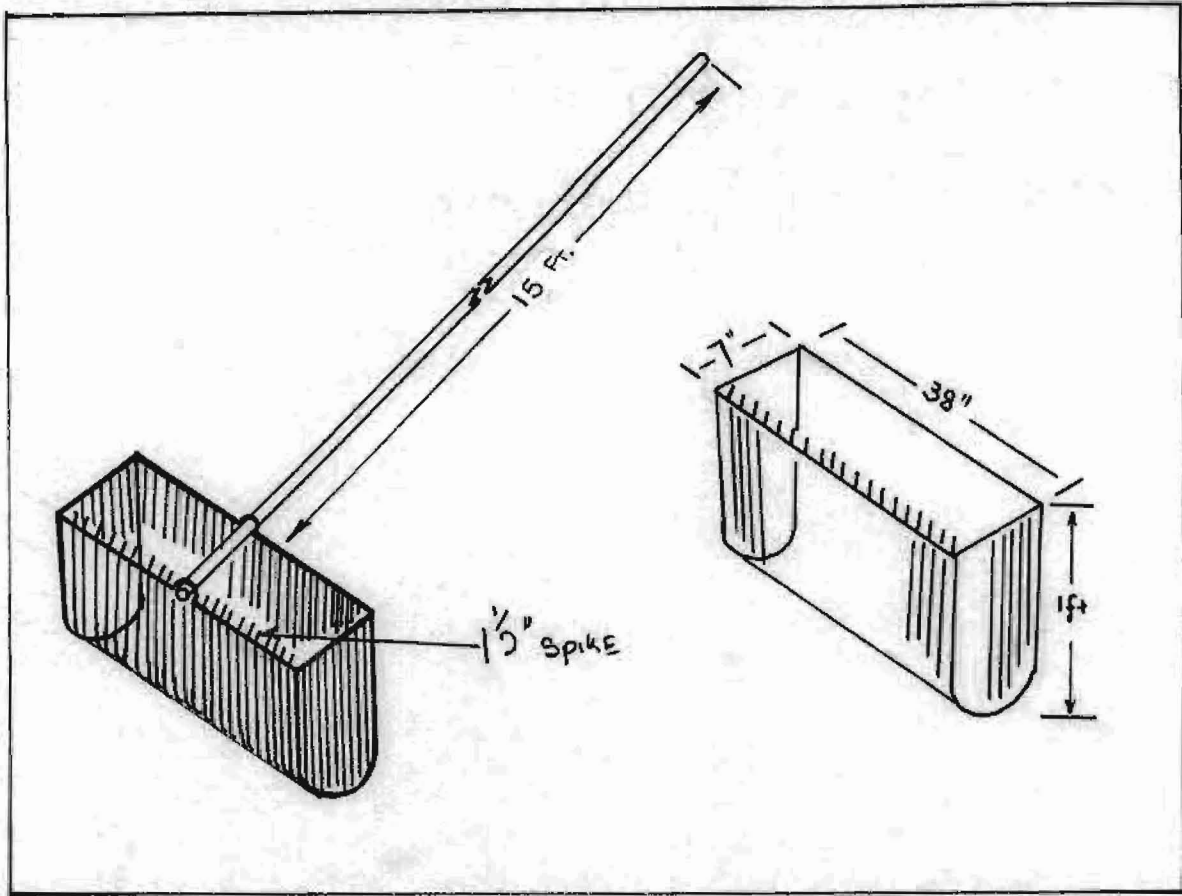

FIG 12.0 THE COCKLE RAKE

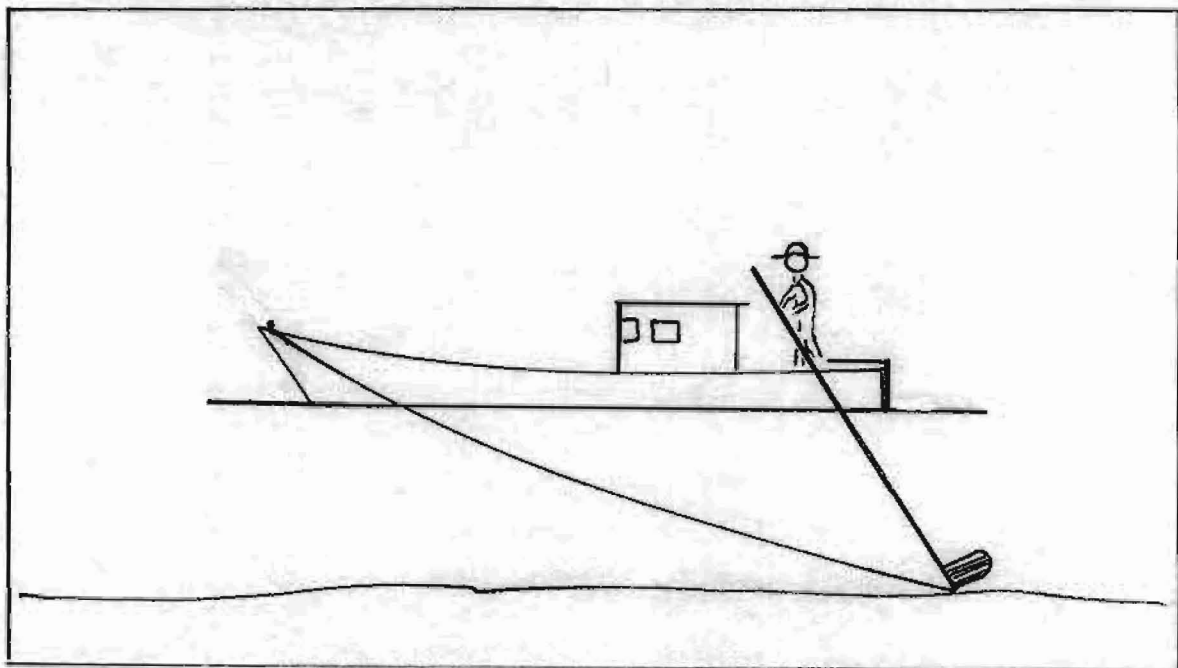

FIG 12.1 THE DREDGING OPERATION

means of a rope. The fisherman then handles the pole. Figure 12.1 shows the dredging operation. Every 4-5 minutes the rake is hauled, the catch washed, and placed in baskets. A normal dredging operation takes about 3-4 hours, collecting anything from a low of 6 to a high of 15 sacks each weighing 160 lbs.

The fishermen are paid for the number of sacks he collects. Payment for a sack of cockle varies from \$4.50/sack in sparsely populated grounds (grounds that have been worked on) to \$2.50/sack in heavily populated grounds. The price paid and grounds to be worked on are predetermined by the owner.

CHAPTER 13

MISCELLANEOUS GEARS

Small gears of every description not classified under the other 10 groups are classed under this group. This includes lift net traps for crabs, squid jigging, cast nets, scoop nets, hooks for rock crabs, and many others. In 1978 the estimated contribution of this gear group was 2000 M.tons amounting to .4% of the total.

13.1. Squid Jigging

Primarily operated in the east coast, squid jigging is operated in the evenings. One or two fishermen operate the gear close to the shore. The fishermen carry pressure lamps used to attract the squid. On arrival at the grounds the lamps are lit and suspended at the side of the boats. The jigger is made of normal fish hooks. Eight to 10 hooks are tied together. This is then welded to a stalk (Figure 13.0). The jigger is then tied to a monofilament line.

The jigger is then lowered into the water, moved in a brisk up and down movement. Squids attracted by the bright light school around the boat, attack the jig and are taken aboard.

13.2. Cast Net

Operated near the shore, lakes and rivers, cast nets

are used mainly for fish and shrimp. The net illustrated in Figure 13.0 is circular in shape with a diameter of between 6-12 feet. It is cast in a circular twist of the arm to spread it wide.

When hauled by means of a toggle string it forms a cone trapping any fish and shrimp in the net. Large cast nets are used from small boats in the mangrove areas for harvesting large prawns.

13.3. Crab Lift Nets (Binto)

Lift nets are used to catch crabs. The net is illustrated in Figure 13.0. With a dimension of 18" square, the net is baited and lowered into the water. Twenty to thirty traps are set in mangrove areas. The fishermen then lift the nets two to three times daily to harvest the catch.

Bait used for the trap include trash fish, fish offal and other bits and pieces of fish.

13.4. Scoop Net for Shrimp

Operated at night, scoop nets for shrimp are worked during low tide. The fisherman goes out to areas near the river mouth or mangrove areas where shrimp are found in abundance.

He carries a torch attached to his head and shines it into the water. When shrimp are caught by the rays of the torch they freeze, allowing the fisherman to use his

scoop net to catch the shrimp. In one evening the catch varies from three to seven pounds of shrimp.

The catch is sorted on the boat and sold in the market or to customers that had made prior arrangements with the fishermen. The gear can be worked from a boat or by the fishermen wading in the water. The equipment used by the fishermen is illustrated in Figure 13.0.

13.4. Hook for Crabs

Metal hooks attached to long poles are used to catch mangrove crabs. The operation is done during low tide. Fishermen will track along the mangrove swamp looking for burrow holes in the ground. The hook is then placed in the holes. If it is habited some movement can be felt. The hook is then worked such that it catches the crab between its walking legs and hauled towards the surface.

Once on the surface, the crab is held by pressing it into the ground. The claws are then tied followed by tying the legs. The fishermen then continues looking for other burrow holes.

Among the many other gears grouped under miscellaneous gears are fishing by means of poison or explosives. At one time these methods were commonly used.

The use of such fishing methods is now prohibited under the Fisheries Act of 1963. Section 12(1) of the Act specifies that any person who, except under the authority

of a license issued under this Act, uses any poisonous or explosive substance with intent to stupefy, poison or kill fish shall be guilty of an offense. This provision is further strengthened under Section 12(2). Any person who is found in possession of fish which has been captured with the aid of any explosive or poisonous substance and who does not give a satisfactory account as to how he came to be in possession thereof, shall be guilty of an offense.

The combination of laws regarding the use of such substances has been very effective. No such fishing methods are presently operated.



Squid Hook

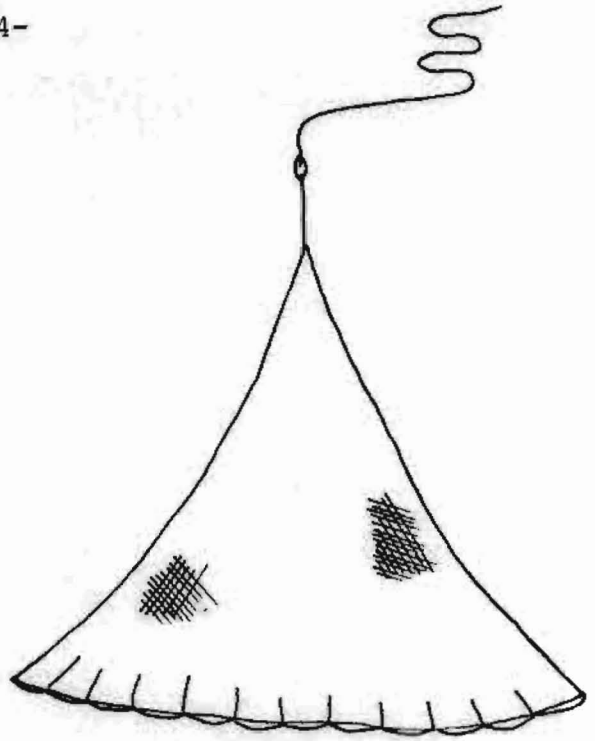

CAST NET

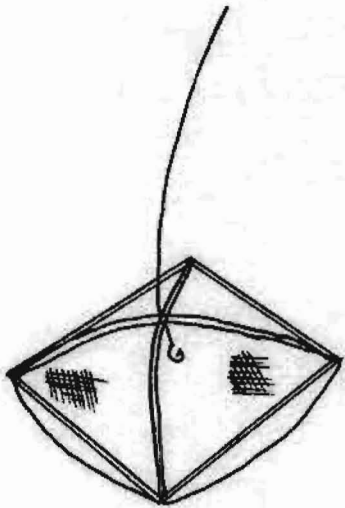

CRAB LIFT NET

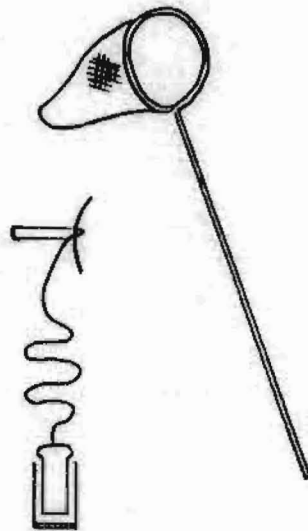

SCOOP NET



CRAB HOOK.

FIG 13.0 MISCELLANEOUS GEAR

CHAPTER 14

FUTURE DEVELOPMENT OF MALAYSIAN FISHING GEARS

There is plenty of room for improvement of the Malaysian fishing gears. The need for improvement encompasses every aspect of fishing such as fishing gears, fishing gear materials, ancilliary equipment, navigational equipment, life-saving apparatus and many others.

Considering that the fishery directly support the livelihood of 83,000 fishermen, deciding and implementing the desirable kind of improvements is not clearcut. Whereas super-efficient vessels can be designed and operated, this will displace the present number of fishermen. To some, the efficient units are the answer to ensuring optimum production at minimum cost thereby increasing economic rent and diverting excess investments to other sectors of the economy. Yet others believe that such a course of action will create great social externalities. There are no hard and fast rules to such alternatives.

The answer to this problem probably lies somewhere in between and will depend on the specific situation surrounding the case and the nation's development priority. Malaysia has addressed this problem by attacking both factors in its fishery development policy. It contains two primary elements; viz

- a) to manage and regulate the exploitation of the fishery resources with the view to realizing the optimum production of fish and fishery products to ensure availability at reasonable prices;
- b) to increase the productivity, income and socio-economic level of fishermen and fish farmers.

This policy incorporates both a production and social goal. These two policies are not always compatible. For instance, highly efficient vessels aimed at achieving the production goals will result in displacement of fishermen. Capital cost to improve fishing gear may be too prohibitive for the large portion of poor fishermen, causing greater social stratification. Yet again the overcapitalization of the presently exploited stock is certainly in conflict with the concept of optimum utilization.

How then should fishing gears be developed? One manner in which to approach the problem is to determine guidelines that will ensure development that will make the objectives compatible.

Suggestions of these guidelines are listed below:

- a) to improve the fishing gears
- b) fishing gear improvements should be channelled towards improvement of the socioeconomic level of the fishermen
- c) to improve the fishing methodology
- d) to keep cost of gear improvement low.

First and foremost the fishing gears should be improved to increase the productivity of the fishing industry. However, these improvements must be geared towards the social well-being and increasing the socioeconomic level of the fishermen. Improvements in fishing methods should lead to longer time ashore, decreasing manual labor through use of simple machinery.

These improvements must be achieved at the lowest possible cost. This will ensure that a major proportion of the fishermen can reasonably afford the improvements while adding no or little additional operating cost. This will also mean cheaper prices for the consumers.

Thus the development of the Malaysian fishing gears should be achieved by innovation within the present industry using cheap locally available material versus importation of sophisticated and expensive ancilliary gears.

Corresponding to the policy objectives and guide lines described, the expected future development in the Malaysian fishing gears are described below.

14.1. Improvement in Fishing Gear

Fishing gear materials:

Synthetic netting presently operated in the fishery is not satisfactory. Complaints of nets disintegrating after two years of usage are common. One of the likely reasons for this is the prolonged exposure to abundant

sunlight. Klust (1973) noted that UV rays from the sun affect the strength of synthetic fibers. Improved materials are expected to replace the present ones. Better materials will tend to lengthen the maintenance intervals giving more leisure time to the fishermen.

The use of knotless nets are only common with the purse seines. However, there are plenty of advantages of the knotless nets over the traditional knotted netting. Knotless nets require less volume for the same surface area thereby resulting in a lighter gear with less abrasion and damage to the catch. All this means is that the same size net should cost less (as netting is sold by weight) occupies less space and improves the quality of the catch.

Rigorous testing of hexagonal nets in Norway and Germany has indicated that these nets incorporate all the features of a knotless net while assuring the shape of the mesh opening. This may result in better mesh selectivity in the gear. When proven successful, these nets are expected to be employed to improve local gears.

Towed gears being the most important gears, are constantly being improved. In terms of materials, present innovations are in the doing away with floats. Materials placed on the top bosom act as a kite to cause the head rope to rise. The use of this innovation will incorporate necessary design changes in the traditional trawls. Such developments will lower the cost of nets and replace the need of floats in trawl headlines.

While for a long time chains were used to weight the trawl footrope, the use of bobbins is becoming more popular in Malaysian trawls. Bobbins protect the net while fishing on hard bottoms. Bouncer gears,¹ however, should not be encouraged if there is a tendency for such gears to be used in coral areas to harvest the rich resources of coral beds.

Fishing gear design:

Only in the last three to four years have the trawl nets in Malaysia exhibited the use of large 9-inch meshes in the wings. Prior to this a 3-4¹/₂ inch mesh size on the wings was common. The use of larger mesh sizes results in less drag on the gear allowing vessels of the same horsepower to tow a larger net. As larger swept areas can be equated with better catches, such improvements lead to more efficient gears. The Malaysian trawls are continually improved by incorporating design improvements to increase the sweep area by using longer ground ropes and using cut off or butterfly wing designs to increase the headline weight of the nets. Although four seam trawls are not operated presently, it is expected that with the introduction of midwater trawling such gears will be introduced.

Midwater trawling is presently introduced as a pilot project in the Malaysian fishery. These gears are operated in coral areas. Aimed trawling techniques mean less

¹A ground gear capable of bouncing the net off the ground when meeting any obstacle.

time required for locating fish schools and shorter towing time for larger catches. Developments in other gears include stronger and lighter materials for purse seines, use of monofilament gillnets, and use of braided headlines and footropes to minimize twisting.

Selectivity of fishing gears:

Fishing gear selectivity has not been fully addressed in the world. In a multispecies fishery like Malaysia, only token recognition has been accorded to gear selectivity because of problems related to capture of mature but small-sized species. Gullard (1974) addressed the problem that most fishery management plans tended to make fishing gears less efficient. This conflicts with the concept of optimum yield.

To ensure the achievement of optimum yield, the concept of selectivity must be changed towards more efficient gears through the introduction of selective features. For example, personal communications with the Rhode Island lobster fishermen have shown that most of them voluntarily have a 1-3/4" escape hatch in the lobster pots. This practice actually improves the catch of legal sized lobsters. The escape hatch allows sublegal size lobsters and crabs to leave the pot for legal size lobsters to enter it.

Larger cod end meshes allows a substantial portion of trash fish to leave trawls. This improves the productivity of the gear by decreasing time lost to sorting fish

and higher grade fish means higher value. This experience was communicated by a ranking officer with the Malaysian Fishery Development Authority. Although the present state of the art in gear selectivity does not allow specific recommendations, positive indications of effectiveness of gear selection acting compatible with optimum utilization is a step forward. In Malaysia more efforts towards the study of gear selection is needed. It is envisaged that this will be an important component of fishing gear development in the future.

Together with gear selectivity is the question of ghost fishing. This is a term used to describe the continued capture of fish by lost gear. Ghost fishing is gaining importance in any discussion of fishing gear developments and will play a role in future fishing gear development.

Fishing methods:

The present fishing methods employed in Malaysia are relatively archaic if compared to those of advanced fishing nations. However, it must be recognized that although traditional in nature, it has positive features such as low capital investment and effective enough for the present needs of the fishery. Efforts to improve fishing methodology must take into consideration these positive features. Immediate need of the industry is improvement in gear handling methods and should be geared to the development of simple winches, net haulers and other mechanical aids

developed locally through local materials and technology. This can be achieved at a fraction of the cost of imported ancilliary gears.

Improvements must be made to the present fleet rather than the purchase of large, sophisticated and expensive new vessels. A caveat is appropriate to clarify a point. In the development of offshore fishery in the exclusive economic zone the operation of larger, more sophisticated vessels is desirable. However, insofar as the present in-shore fishery improvements must be made to the present fleet.

The role of research in the development of Malaysian fishing gear is insignificant. Fishing gears have developed in an uncoordinated manner through the efforts of enterprising fishermen.

The result of such a developement is the proliferation of destructive gears rendering fishery management plans difficult to implement. The importance of fishing gear research is becoming more prominent and must be coordinated to achieve a fishing gear development program that satisfies the guidelines to achieve the objective of fishery development.

REFERENCES

1. Malaysia, Division of Fisheries, Ministry of Agriculture. Annual Fishery Statistics 1978 (Kuala Lumpur, Government Printing Office, 1949), p. 150.
2. Malaysia, Division of Fisheries, Ministry of Agriculture. The State of the Fishing Industry and Its Contribution to the National Economy (Kuala Lumpur, Division of Fisheries 1978), p. 20.
3. Selvadurai, S. Peninsula Malaysia Fisheries. Ministry of Agriculture, Malaysia 1978, p. 33.
4. Malaysia, National Committee. Final report of the Committee on the Utilization of Marine Living Resources. Working group 3-Fishing technology, infrastructure, capital investment and incentive. August 1979. Ministry of Agriculture, Malaysia.
5. Sainsbury, J. C. Commercial Fishing Methods - An Introduction to Vessels and Gear. Fishing News (Books) Ltd. London, 1971, p. 119.
6. Food and Agricultural Organization of the United Nations. FAO Catalogue of Fishing Gear Designs. Fishing News (Books) Ltd. London, 1972.
7. Brandt, A. J. Fish Catching Methods of the World. Fishing News (Books) Ltd. London, 1972, p. 240.
8. Gullard, J. A. The Management of Marine Fisheries. Dept. of Fisheries, Rome. University of Washington Press, Seattle, 1974.
9. Selected Works of Fishing Gear, trans. F.I. Baranov. Vol. 3. Commercial Fishing Techniques. Israel program for scientific translation. Jerusalem 1976.
10. Klust, G. Netting Materials for fishing gear. Fishing News (Books) Ltd. England, 1973.