

Influence of ceramic nanoparticles on fatigue life of Al 6061 prepared via ultrasonic aided rheo-squeeze casting process

Karthikeyan Ramachandran, Constance Linda Gnanasagaran, R Ram Subramani, Vignesh Boopalan & T Arunkumar

To cite this article: Karthikeyan Ramachandran, Constance Linda Gnanasagaran, R Ram Subramani, Vignesh Boopalan & T Arunkumar (2023): Influence of ceramic nanoparticles on fatigue life of Al 6061 prepared via ultrasonic aided rheo- squeeze casting process, *Advances in Materials and Processing Technologies*, DOI: [10.1080/2374068X.2023.2205673](https://doi.org/10.1080/2374068X.2023.2205673)

To link to this article: <https://doi.org/10.1080/2374068X.2023.2205673>



© 2023 The Author(s). Published by Informa UK Limited, trading as Taylor & Francis Group.



Published online: 27 Apr 2023.



Submit your article to this journal [↗](#)



Article views: 64



View related articles [↗](#)



View Crossmark data [↗](#)

Influence of ceramic nanoparticles on fatigue life of Al 6061 prepared via ultrasonic aided rheo- squeeze casting process

Karthikeyan Ramachandran ^{a,b}, Constance Linda Gnanasagaran ^a,
R Ram Subramani ^{c,f}, Vignesh Boopalan ^d and T Arunkumar ^e

^aSchool of Engineering and the Environment, Kingston University, London, UK; ^bSchool of Mechanical, Aerospace and Automotive Engineering, Coventry University, Coventry, UK; ^cDepartment of Management, Indian Maritime University, Chennai, India; ^dCO₂ Research and Green Technologies Centre, Vellore Institute of Technology, Vellore, India; ^eSchool of Mechanical Engineering, CMR Institute of Technology, Bangalore, India; ^fKuehne+Nagel International AG Ltd, India

ABSTRACT

The fatigue behaviour of Al 6061 along with its ceramic nanoparticles reinforced cermets fabricated through ultrasonic-aided rheo-squeeze casting technique are evaluated. The fatigue behaviour was studied under ambient and elevated temperature (250°C) conditions, and the effect of notches was also examined under same stress conditions. Al 6061 indicated service life of ~1.15 million cycles at low stress value which dropped to 15,470 cycles with increase in stress magnitude. Al cermet (ALST) showcased enhanced = fatigue life up to ~35% for hybrid cermet with highest service life of 1.71 million cycles due to load transfer mechanism. In elevated temperature condition, life of Al 6061 dropped by 37%, whereas the reinforced cermets remained higher with ALST revealing high service life cycles. Further, notch indicated drop in fatigue life of Al and its cermets with cermets prevailing better than Al. The elevated temperature notch represented the lowest fatigue life owing to stress concentration as well as the coefficient of thermal expansion mismatch.

ARTICLE HISTORY

Accepted 17 April 2023

KEYWORDS

Aluminium 6061; nanoceramics; Cermets; Rheo-squeeze casting; Fatigue behaviour; High temperature fatigue

1. Introduction

Aluminium-based alloys are widely used in automotive and aerospace industries in the areas such as wings, rudder, exhaust pipes and fuselage owing to its lower density, high strength-to-weight ratio, good creep resistance and chemical resistance along with rapid and lower manufacturing cost. Further, its utilisation is not only limited to aerospace but it also extends towards military, marine, construction, automotive, and other dynamic load-bearing applications [1]. Despite its extensive applications, use of aluminium is mostly limited to room temperature applications owing to its high thermal expansion, poor hardness, and service life at elevated temperatures, leading to need of reinforcements to enhance the

CONTACT Karthikeyan Ramachandran  K1825123@kingston.ac.uk  School of Engineering and the Environment, Kingston University, Roehampton Vale Campus, London SW15 3DW, United Kingdom

© 2023 The Author(s). Published by Informa UK Limited, trading as Taylor & Francis Group.

This is an Open Access article distributed under the terms of the Creative Commons Attribution-NonCommercial-NoDerivatives License (<http://creativecommons.org/licenses/by-nc-nd/4.0/>), which permits non-commercial re-use, distribution, and reproduction in any medium, provided the original work is properly cited, and is not altered, transformed, or built upon in any way. The terms on which this article has been published allow the posting of the Accepted Manuscript in a repository by the author(s) or with their consent.

Table 1. Sample composition and notations.

Samples	Composition
AL	Aluminium 6061
ALS	Aluminium 6061 + 2% SiC
ALSA	Aluminium 6061 + 2% SiC + 2% Al ₂ O ₃
ALST	Aluminium 6061 + 2% SiC + 2% TiO ₂

properties [2]. Ceramics such as Al₂O₃, SiC, TiO₂ and B₄C have been reinforced with aluminium to enhance the physical and mechanical properties [3–6]. However, owing to thermal expansion mismatch, weak interfacing bonding between ceramics and metal particles leads to lower thermal conductivity (TC) and undesirable degradation. Further, micro-sized reinforcements have failed to provide desired mechanical and thermal properties to aluminium [7].

Therefore, various researchers have tended their direction towards nanoparticles which utilise special reinforcement mechanisms like Orowan mechanism which is a thermal discrepancy technique to enhance the strength of the cermets based on applicational requirements [8,9]. There have been various techniques which detail the fabrication of Al-based cermets including techniques such as casting, infiltration, and powder metallurgy [10]. The development of high-performance cermets is crucial owing to the fabrication method where the floating of nanoparticles tends to provide a big challenge on the molten liquid as it leads to agglomeration and cluster formations [11]. Techniques such as double casting and vortex methods were developed to fabricate the cermets. However, high stirring speed allowed air traps, leading to enhanced porosity [12]. Hence, there were few research to control the speed and further determine the ideal stirring speed which led to non-uniform distribution of nanoparticles leading to agglomeration [13]. Researchers have replaced the vortex method with ultrasonication to enhance distribution which improved mechanical properties, but due to no external pressure, porosity still existed within the cermets [14]. Thus, an external pressure was necessary to deliver high-performance cermets, and squeeze casting was stated to replace the stir cast method due to the defect free surface with reduced cavities and porosities [15]. However, the technique failed to distribute the nanoparticles uniformly throughout the cermet, leading to agglomeration [16].

In our previous research, a novel fabrication technique was utilised which uses external pressure, ultrasonication and stir casting to produce high-performance cermet with reduced porosity and cavities, and its mechanical and thermal properties were reported [8,9]. In this paper, fatigue behaviour of cermets (Table 1) under ambient temperature and high temperature environment (250°C) which were fabricated through the ultrasonic-aided rheo-squeeze casting process will be investigated. This paper also studies the effect of material parameters and mechanical properties on fatigue notch sensitivity of AL 6061 and its cermets. The study signifies the need for lightweight materials in various structural application would potentially look for Al-based alloy as a replacement in aerospace structure including fuel tanks and bodies.

2. Materials and methods

2.1. Materials

Aluminium 6061 ingot alloy was fabricated utilising Al 6061 ingot, magnesium and hexachloroethane (degasser) as starting materials which were procured from Chemco Engineering Pvt. Ltd., Chennai. Nanoparticles of titanium oxide (TiO_2), silicon carbide (SiC) and aluminium oxide (Al_2O_3) with size ranging between “30 and 40 nm” were obtained from MK Industries, Canada, which were used as reinforcement ceramic materials.

2.2. Fabrication technique

The detailed fabrication technique of Al 6061 alloy and its cermets is described in previous research works along with its scanning electron microscopy (SEM) and energy dispersive x-ray spectroscopy characterisations [8,9]. The Al alloy was fabricated using tailor-made aluminium squeeze casting machine. The base alloy was heated to 650°C in a stir casting machine by subsequently adding in C_2Cl_6 to degas the alloy. Then, molten liquid was cooled into to a semi-solid form at 500°C to remove the clusters and agglomerations and reheated to 750°C with constant stirring at 300 rpm speed to improve wettability. The molten liquid formed was ultrasonicated at 20 kHz for 5 min for complete dispersion of clusters and poured into a preheated (400°C) steel die of required shape and squeezed at 50 MPa and then cooled down to room temperature. Finally, the samples were heat treated for 530°C for 5 h as per T6 procedure and quenched in water aged at 160°C for 24 h. Figure 1 illustrates the design of the fatigue samples prepared through casting process. In case of cermets, the nanoparticles were ball milled for 5 h at 300 rpm and pre-heated to 300°C and then introduced in the stage of stir casting followed with above steps.

2.3. Notch machining and testing technique

The effect of notch was studied by introducing a “V” notch on the middle of specimen through machining using a lathe with help of a diamond insert. The notch was made in such a way that it was 5% of both thickness and width of the sample. Ambient condition

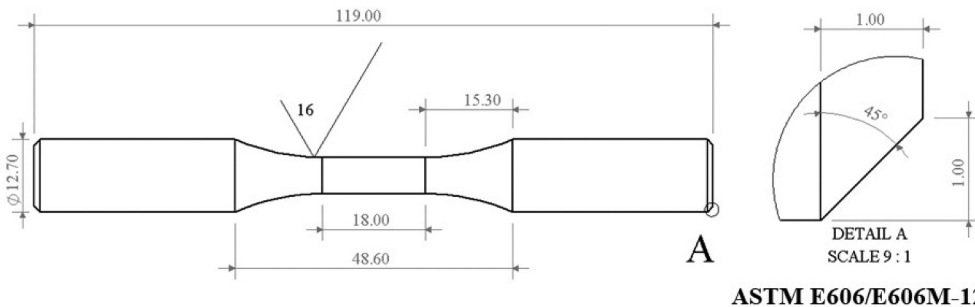

Figure 1. Schematics of fatigue testing samples prepared via fabrication.

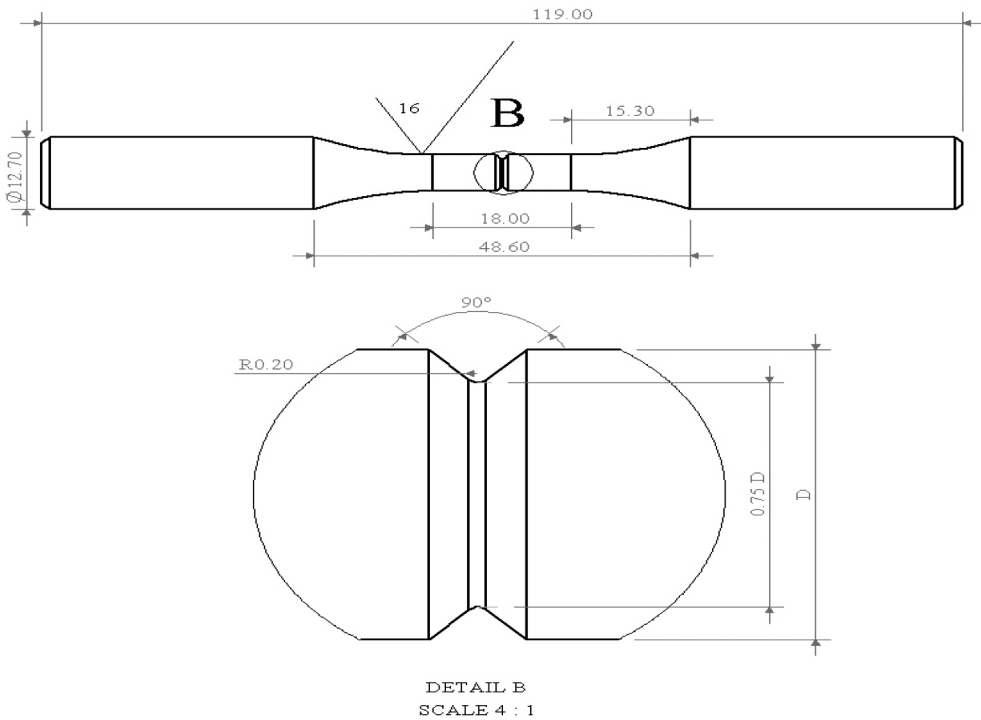

Figure 2. Dimensions of notches machined on the fatigue samples.

static fatigue behaviour of the Al 6061 and its cermets was conducted as per ASTM E606/E606M–12 standards using Zwick Roell Amsler HC 25 fatigue testing machine. The test was conducted with stress ratio of $R = -1$ and frequency of 10 Hz with test ending at either at failure or to endure maximum cycles of 5 million. Elevated temperature fatigue testing was conducted using MTS Universal testing machine at a temperature of 250°C with the same criteria as the ambient testing. Different stress range varying from 2 to 3.6 kN was studied and for each stress three test were conducted. The dimensions of the notches are provided in Figure 2. The fractured surfaces of fatigue samples were analysed for its failures through Zeiss Axio Imager 2 Pol (India) and SEM were attained through Zeiss Evo SEM (India).

3. Results and discussion

3.1. Ambient and high-temperature fatigue behaviour

Ambient temperature fatigue test was conducted with varying ultimate tensile strength (20–80%) which were applied to fabricated Al 6061 and its cermets to estimate the fatigue life. The ultimate tensile strength data were attained from previous work and are reported in Table 2 [8,9]. Figure 3 plots SN service life plot of Al 6061 and its cermets from which it is observed that there is a significant reduction in number of cycles with increase in UTS load. The results shows that the sample with 20% UTS failed after 1 million cycles whereas with higher stress of 60% UTS, Al 6061 failed at ~ 15000 cycles. On the other

Table 2. Percentage of ultimate tensile strength utilised for fatigue at room temperature.

Percentage (%)	Tensile strength (MPa)
20	286
30	270
40	253
50	236
60	219
70	202
80	185

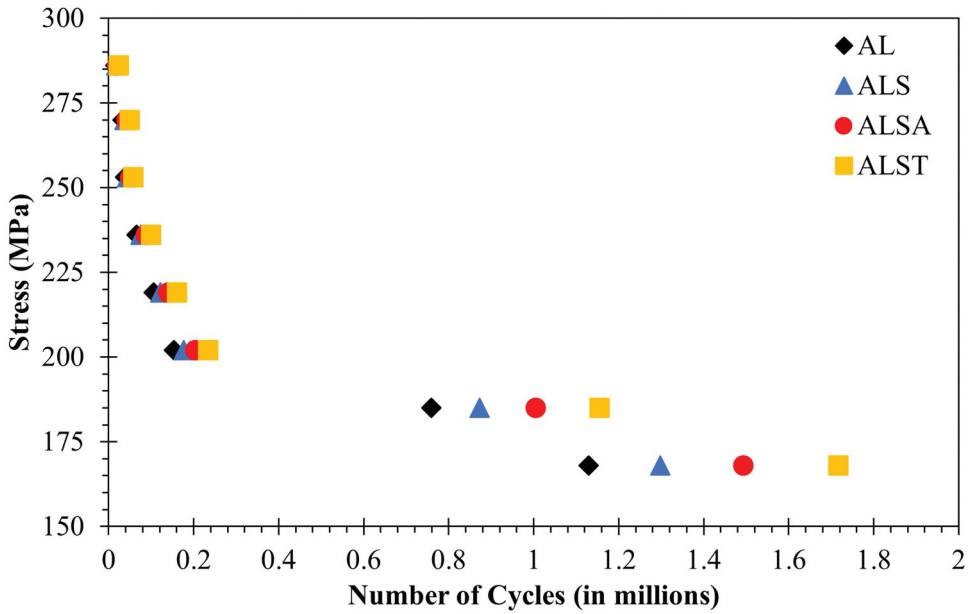

Figure 3. SN plot of Al 6061 and its cermet at ambient temperature.

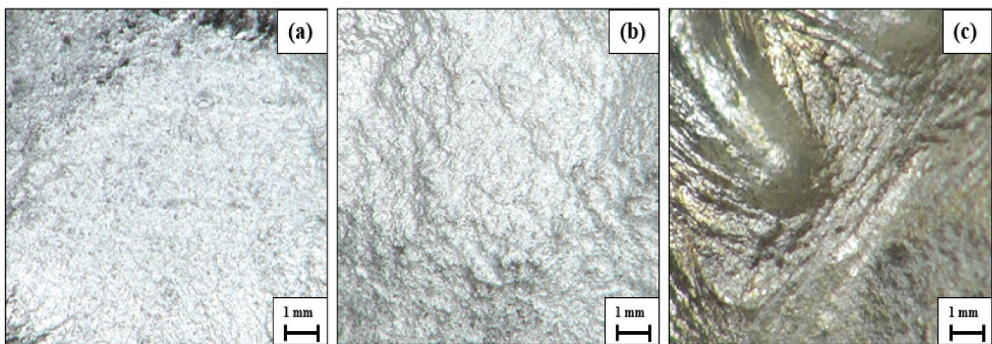

Figure 4. Fatigue damages of (a) low stress value, (b) medium stress values and (c) high stress value for Al 6061.

hand, ALS and ALSA cermets were able to withstand ~13% and ~24% more than Al 6061. The hybrid cermet with TiO_2 (ALST) evidenced an enhanced service life of ~34% compared to Al 6061.

Figure 4 displays the microstructure for the damaged area of Al 6061 at three different stress loading conditions, i.e. low stress (185 MPa), medium stress (236 MPa), and high stress values (286 MPa). From Figure 4, it is evident that Al 6061 had different behaviour with respect to loading conditions. With low stress values, Al 6061 showcased a clear surface with low parabolic dimples and large series of defects at the edges. However, dimples enhanced vertically with increase in the loading values/stress values with internal crack propagation. Further, some black spots were determined at closer observation indicating presence of defects on the surfaces. However, with increase in the stress values, there were a clear formation of dimples throughout the surfaces and initiated crack propagation at the corners when further enhanced with stress values. The high stress samples indicated huge amount of chips and dimples on the surface exhibiting ductile behaviour. Further, while observing the failures on Al 6061 it is noted that most of the failures were vertical in nature with principal stress under uniaxial tension which indicates that the dominant failure mechanism may be of brittle fracture with increase in loading values.

However, ceramic-nanoparticles-reinforced Al 6061 cermets indicated reduced crack propogations with limited vertical dimples as shown in Figure 5. Even at high elemental composition, cermets reinforced with SiC indicated a dense crack transversing internally whereas Al cermet reinforced with TiO_2 and SiC indicated no cracks attributed towards the strength mechanism which enhanced the load bearing capacity by transferring load of matrix to reinforcement particles [17]. Further, traces of defects were formed on the surfaces of the ALST as illustrated in Figure 5(b) which could have been due to the failure. Further to loading bearing behaviour, higher interfacial bonding between matrix and reinforcement which could have enhanced due to homogeneous distribution of particles might have inhibited nucleation and damage growth during fatigue [18]. Our previous studies correlates that the attained results could have been due to homogeneous distribution through ultrasonication prior to casting process. This allowed the metal matrix to attain structural stability with higher load transfer mechanism [8,9].

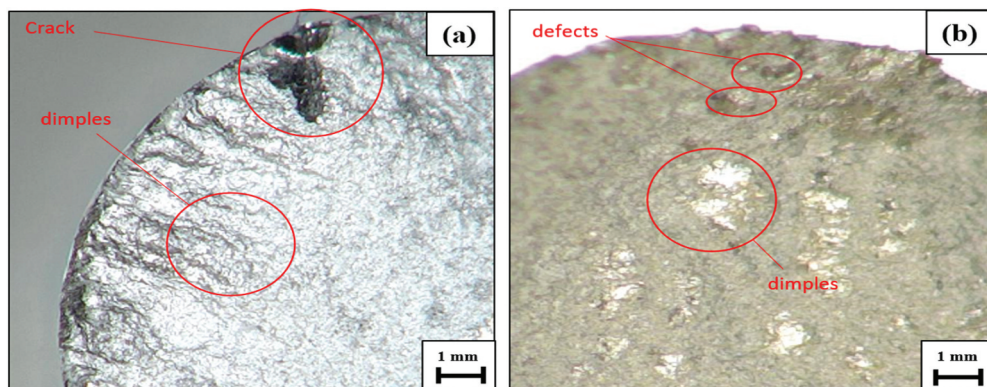

Figure 5. Microstructural damages after fatigue at high stress (60% UTS) of (a) ALS & (b) ALST.

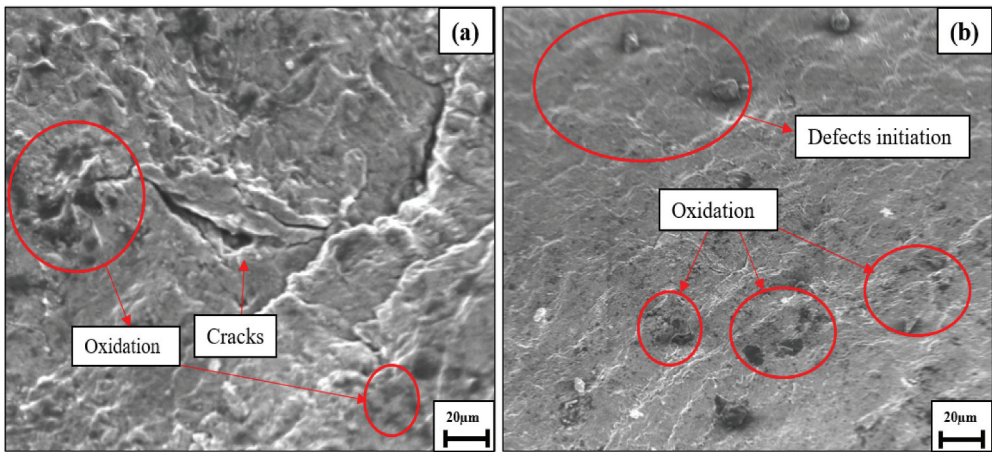

Figure 6. SE microstructure of high stress damage on (a) AL and (b) ALST.

SEM images of the fractured surfaces of AL and ALST are illustrated in Figure 6(a) and 6(b) and it can be seen that the AL initiated internal oxidation due to the casting temperature. Also, rapid cracks are visible which are propagating from the corner to centre. In contrast, ALST indicated clear surface with limited cracks and minimal defect initiation. There were some dark spots on the surface of ALST which could have been due to oxidation as well. The difference between AL and ALST was evident possibly due to the transformation of TiO_2 to its rutile structure while reinforcing in high temperature slurry [19]. The presence of rutile TiO_2

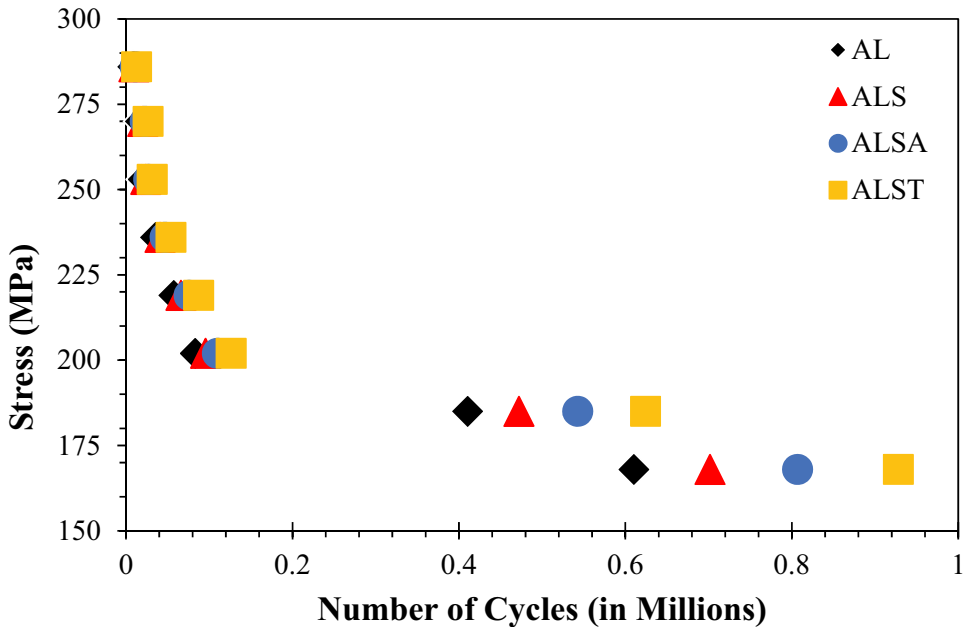

Figure 7. Fatigue service life of Al 6061 and its cermets at high temperature 250°C.

could have supported in enhancing the load transfer behaviour between matrix and reinforcement resulting in simultaneous increase in the fatigue life [20].

From data reported in Figure 7, addition of SiC, Al₂O₃ and TiO₂ nanoparticles enhanced the fatigue life behaviour in all loading conditions. The highest difference in number of cycles to failure could be seen in minimum loading conditions as AL samples failed at 91,538 cycles prior to ALS samples. Likewise, fatigue life of ALSA samples was more than AL and ALS cermet, this could have been due to addition of Al₂O₃ nanoparticles which decreased the amount of surface discontinuities as Al₂O₃ particulates tend to fill larger-grain boundary deformities [21]. On the other hand, hybrid cermet with TiO₂ (ALST) demonstrated the highest fatigue life (~928112 cycles) at elevated temperature. Such enhancement in fatigue life by incorporating ceramics have been reported previously by various researchers [22,23]. The failure at high temperature could have been due to the thermal mismatches as per our previous reported research [8]. The thermal mismatch due to the different in the TC and expansion coefficient enhances the local shear stresses at the particle-matrix interface at 250°C could probably lead to rupture at high cyclic loading conditions. Further, failure on Al cermet due to incorporation of SiC may also be due to the formation of the precipitates which could lead to dislocations where planar slip occurs which reduces the strengthening effect of cermet causing to rupture [24].

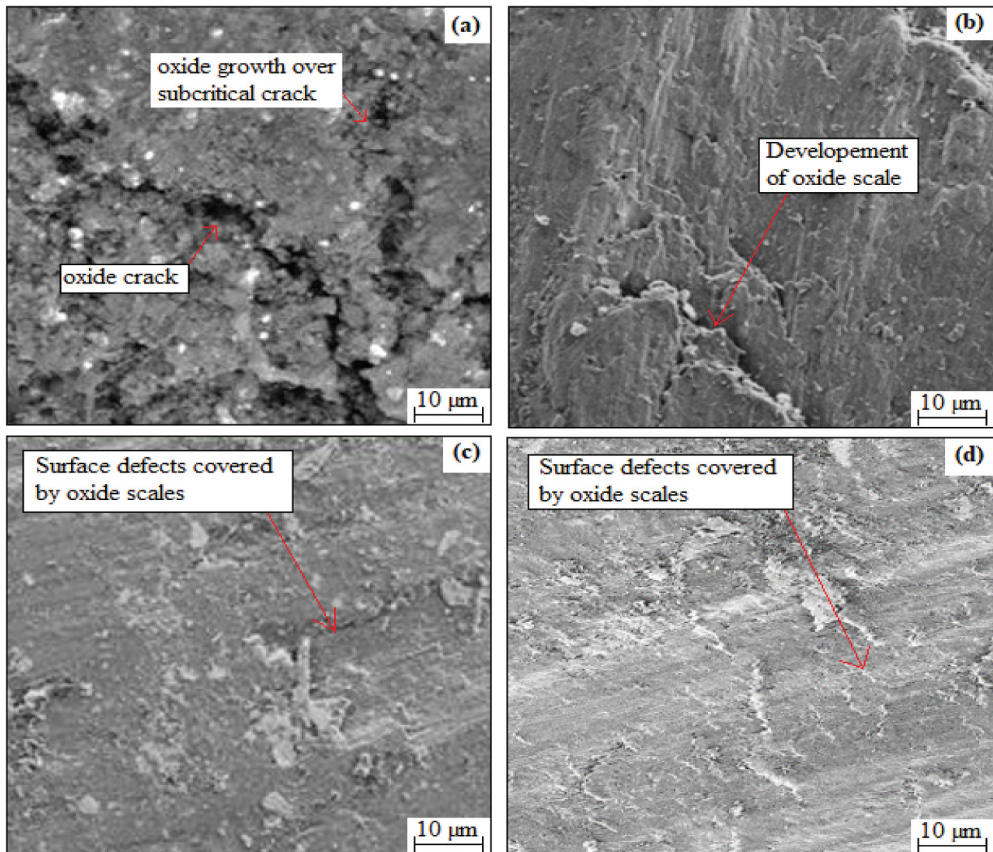

Figure 8. Microstructural surfaces of fractured region after (a) AL, (b) ALS, (c) ALSA and (d) ALST.

Figure 8 illustrates the fractured region of Al and its cermets after fatigue testing at 250°C. The fractured surface of Al indicated a coarse grain sizing due to the absence of ceramic reinforcements at the grain boundaries. Whereas other cermets which had ceramic reinforcements indicates a fine grain sizing between the particles owing to the bridging between the nanoparticles and metal. This particle bridging could have been due to the homogeneous distribution through ultrasonication [25]. SE images of fractured area of samples are illustrated in Figure 8 reveal partial oxidation on the internal surfaces due to the prolonged holding duration while being tested. The formation of oxide layers could also have supported enhancing the mechanical properties of the cermets. However, at high stress magnitude, the cracks formed on the surfaces of the samples may further oxide, leading to local thermal mismatch leading to enhanced dislocations at area of failure resulting in the accelerated crack growth promoting nucleation leading to rupture [26].

3.2. Effect of the notches at different temperatures

The effect of notches on the fatigue life of Al 6061 and all its cermets at ambient temperature is illustrated in Figure 9. Results indicates that all samples had significant reductions in the number of fatigue cycles where AL, ALS, ALSA and ALST had 40, 30, 19 and 17% of decrease in comparison to unnotched samples at 20–60% UTS. However, it is also noteworthy that the hybrid cermet with SiC + TiO₂ (ALST) still had the highest endurance amongst all the notched samples with only 17% reduction in fatigue cycle compared to un-notched ALST, followed by ALSA with only 19% difference compared to smooth ALSA. The significant reduction in fatigue life of notched samples could be contributed by the inhomogeneous stress concentration at the notch [27]. Owing to the critical location of the notch, the stress at the notch exceeds the yield strength (σ_Y)

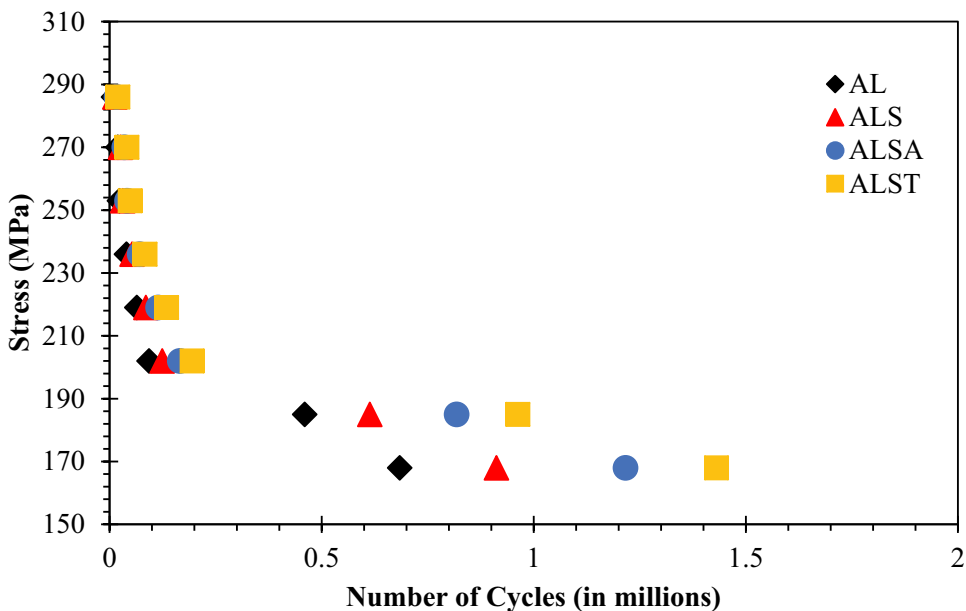

Figure 9. Fatigue behaviour of notched cermets at ambient temperature.

leading to plastic deformation. This deformation along with fluctuating stresses due to fatigue was enough to develop microstructural flaws that eventually lead to failures [28]. Owing to the smaller cross-sectional area at middle portion of the geometry compared to other regions, local stress accumulation takes place at the centre which could lead to failure in the location due to the fully reversed stress ratio of $R = -1$. This explains the failure of Al 6061 and its cermet sustained at higher fatigue stress magnitudes [29]. Further, as the middle region is a critical area for stress concentration, presence of a notch amplifies the stress intensity, hence contributing to premature failure compared to smooth samples.

Further, in our previous report we indicated that even with external pressure, squeeze casted Al alloy showcased presence of pores due to improper cooling profiles of molten metal [8,9]. However, in this case, due to presence of notches which already reduced the cross-sectional area had higher effect on fatigue life than porosity [28]. This explains the 40% reduction in number of cycles in notched AL compared to the similar unnotched sample. However, hybrid cermets indicated homogeneous distribution of nanoparticles with insignificant agglomeration and clusters with very minimal porosity. The incorporation of the ceramics onto the Al metal could have enhanced the load-bearing capacity of the metal due to the internal load transfer behaviour of reinforcement which could result in enhancing the hardness and other mechanical properties. This

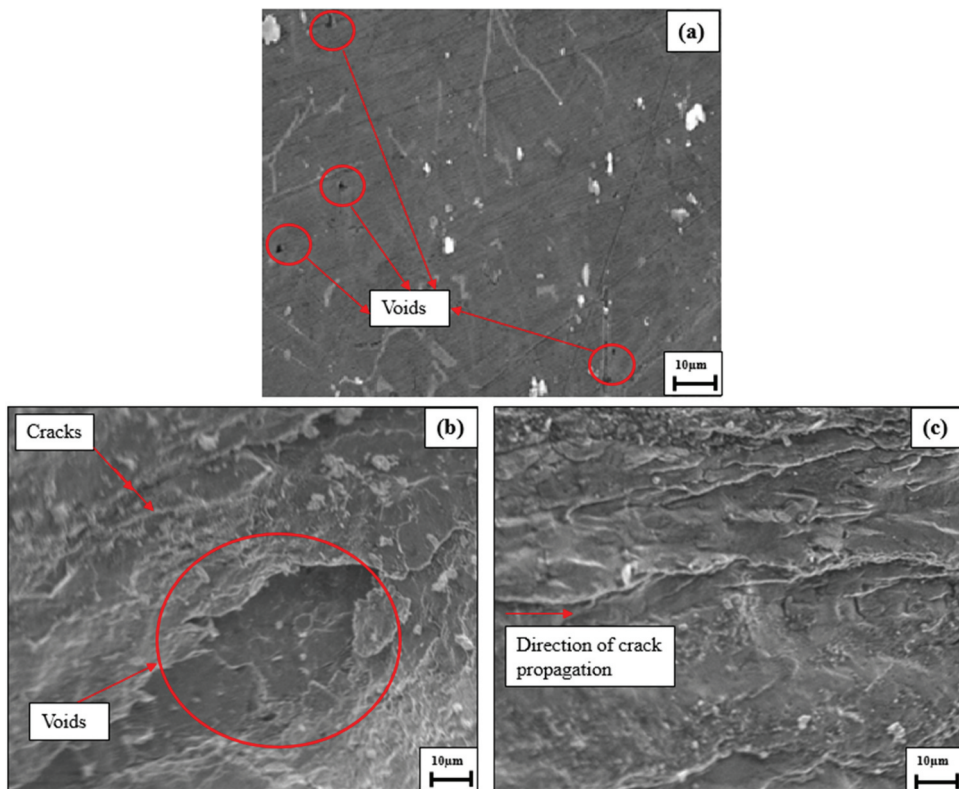

Figure 10. Cross-sectional microstructural area of (a) unnotched AL, (b) fractured surfaces of notched AL and (c) fractured surfaces of notched ALSA.

enhancement in the properties could have supported in increase in fatigue life of the cermets even with presence of notches.

The microstructural fractured surfaces of AL and ALSA cermets are illustrated in Figure 10. From Figure 10, it could be seen that the notched surface of Al had an internal void from which cracks propagated towards external area. Further, there were also lot of visible crack propagation from the external surfaces to internal of the voids. The presence of voids could have been due to the improper cooling profiles of the molten metal while squeeze casting process [8]. Further from microstructure, most of the cracks were denoted to be from external to internal region indicating the high stress concentration on the notches could have enhanced the fracture. Likewise, ALSA cermets also indicated internal crack propagation with patterned cracks on the surfaces. The cracks more likely to be only occurred on the external surfaces and left the centre domain least affected.

Figure 11 represents the effects of notched samples subjected to fatigue loadings at 250°C. Similar to the samples tested at ambient temperature, Al and its cermets demonstrated similar pattern of endurance as compared to smooth samples. With notch, Al failed at 122,000 cycles less (~29% reduction) than the unnotched sample at 20% UTS. It is also evident that except for Al, all the other cermets had ~50% less endurance at high temperature compared to ambient temperature when applied stress was below 200 MPa. The cermets had such significant reduction in fatigue strength at high temperature could be related to the thermal stresses induced within the structure [8,9]. As the notches were already subjected to high mechanical stress concentrations, machined notch area interacts has the effect on thermal stresses which promotes remature fatigue damage [30]. The early failure of samples in high temperature could also be related to varying thermal coefficient in Al its cermets. The variation in TC and coefficient of thermal expansion (CTE) for all the samples were reported in our

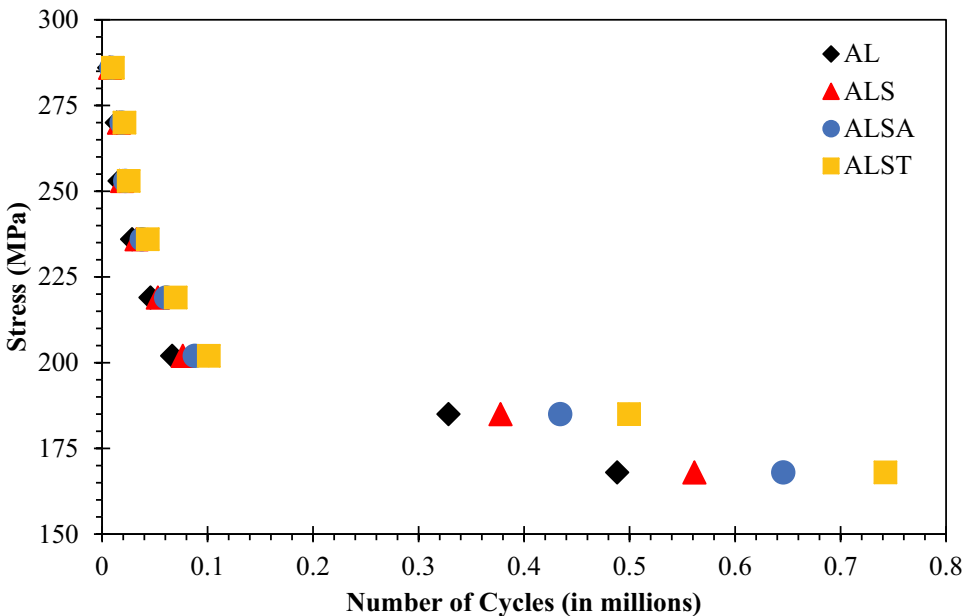

Figure 11. Effect of notches on high temperature.

previous study [8]. ASL, ALSA and ALST all showed significant reductions in both TC and CTE relative to Al 6061. This reduction could be due to the mismatch in the cermet matrix and reinforcement. Based on rules of mixtures, addition of ceramic nanoparticles has the possibility to reduce thermal expansion and CTE as ceramics have much lower CTE compared to Al [31]. The pre-existing stress concentration in the notch, and the accumulation of heat energy within the material as a result of limited thermal expansion could have resulted in much lower fatigue cycle endurance of all the cermets. It is hypothesised that there could have been matrix cracks especially around the notch area due to the mismatch in thermal coefficient between the matrix and the reinforcement. These matrix cracks serve as diffusion paths for oxidants, and cermets degrades faster when loaded with applied stresses, i.e. fatigue and thermal that induces appreciable failure profile [32]. The reduction in TC and CTE of the hybrid composites could also be a result of the lattice distortion at the mechanical and physical interfaces of matrix and reinforcements. This leads to reduced particle size with induction of thermal stress in the interface hence resulting in decrement in CTE. With the pre-existing vulnerability of the material with notch, this condition might have lead to an early fatigue rupture.

4. Conclusion

Al 6061 and its cermets prepared via novel rheo-assisted squeeze casting were evaluated for its fatigue behaviour at ambient and elevated temperature environments (250°C). Further, the effect of notches on same conditions were also verified to understand the fatigue life. Al 6061 indicated a fatigue life of ~1.15 million cycles at low stress magnitude which dropped to ~15000 cycles when increase in stress magnitude. Further, in high-temperature environments, AL indicated over~45% loss in fatigue life for 20% UTS. On the contrary, incorporation of ceramic reinforcements indicated closer or better service life in case of ALSA (2% SiC and 2% Al₂O₃) and ALST (2% SiC and 2% TiO₂) with ALST evidencing superior fatigue life of ~30% more than AL in both ambient and high-temperature environments. This could have been due to homogeneous distribution of ceramic nanoparticles which enhanced the load transfer mechanism between matrix and reinforcement. In case of notched specimens, fatigue life of ambient conditions Al 6061 dropped by ~40%, whereas cermets with TiO₂ reinforcement only represented ~17% loss. This reduction could have been due to the enhancement in the mechanical properties of the cermets due to the reinforcement. In high-temperature notched environment, owing to the variation in thermal properties like CTE and conductivity, there was a mismatch and potential lattice distortion which may have affected the service life. In simple terms, it is concluded that the addition of ceramic nanoparticles have proven to be beneficial towards the structural integrity of 6061 aluminium alloy in terms of withstanding continuous uniform or non-uniform loadings. The study on notch sensitivity of 6061 aluminium alloy also indicates that the addition of ceramic nanoparticles will enable the structure to hold its integrity in presence of tiny fractures or imperfections that could crop up as a result of continuous use under different conditions. This can be related to the dynamics of bridges and how incorporating ceramic nanoparticles to trusses could enable enhancement of service life of the bridge.

Disclosure statement

The authors declare that they do not have any known competing financial or personal relationship that could have appeared to influence the work in the paper.

ORCID

Karthikeyan Ramachandran  <http://orcid.org/0000-0003-2246-7309>

Constance Linda Gnanasagaran  <http://orcid.org/0000-0002-9982-8216>

R Ram Subramani  <http://orcid.org/0000-0002-5450-1041>

Vignesh Boopalan  <http://orcid.org/0000-0002-3184-8755>

T Arunkumar  <http://orcid.org/0000-0003-4425-2878>

References

- [1] Abdel-Gawad SA, Osman WM, Fekry AM. Characterization and corrosion behavior of anodized aluminum alloys for military industries applications in artificial seawater. *Surf Interfaces*. 2019;14:314–323.
- [2] Aboulkhair N, Simonelli M, Parry L, et al. 3D printing of aluminium alloys: additive manufacturing of aluminium alloys using selective laser melting. *Pro Mater Sci*. 2019;106(100578):1–45.
- [3] Gobalakrishnan B, Rajaravi C, Udhayakumar G, et al. Effect of ceramic particulate addition on aluminium based ex-situ and in-situ formed metal matrix composites. *Met Mater Int*. 2021;27:3695–3708.
- [4] Safi M, Hassanzadeh-Aghdam M, Mahmoodi M. Effects of nano-sized ceramic particles on the coefficients of thermal expansion of short SiC fiber-aluminum hybrid composites. *J Alloys Compd*. 2019;803:554–564.
- [5] Prakash S, Sasikumar R, Natarajan E, et al. Influence of feeding techniques in bottom tapping stir casting process for fabrication of alumina nano-filler-reinforced aluminium composites. *Trans Indian Inst Met*. 2020;73:1265–1272.
- [6] Velavan K, Palanikumar K, Natarajan E, et al. Implications on the influence of mica on the mechanical properties of cast hybrid (Al+10%b4c+mica) metal matrix composite. *J Mater Res Technol*. 2021;10:99–109.
- [7] Mazahery A, Abdizadeh H, Baharvandi H. Development of high-performance A356/nano-Al₂O₃ composites. *Mater Sci Eng A*. 2009;518(1–2):61–64.
- [8] Arunkumar T, Pavanan V, Murugesan V, et al. Influence of nanoparticles reinforcements on aluminium 6061 alloys fabricated via novel ultrasonic aided rheosqueeze casting method. *Met Mater Int*. 2022;28(1):145–154.
- [9] Thirugnanasambandam A, Selvakumaran T, Subbiah R, et al. Development of high-performance aluminium 6061/SiC nanocomposites by ultrasonic aided rheo-squeeze casting method. *Ultrason Sonochem*. 2021;76(105631):105631.
- [10] Zhang W, Du Y, Zhang P. Vortex-free stir casting of Al-1.5 wt% Si-SiC composite. *J Alloys Compd*. 2019;787:206–215.
- [11] Soltani S, Khosroshahi R, Mousavian R, et al. Stir casting process for manufacture of Al-SiC composites. *Rare Met*. 2017;36:581–590.
- [12] Khosravi H, Bakhshi H, Salehinejad E. Effects of compocasting process parameters on microstructural characteristics and tensile properties of A356-SiCp composites. *Trans Nonferrous Met Soc China*. 2014;24(8):2482–2488.
- [13] Naher S, Brabazon D, Looney L. Computational and experimental analysis of particulate distribution during Al-SiC MMC fabrication. *Compos Part A Appl Sci Manuf*. 2007;38(3):719–729.

- [14] Madhukar P, Selvaraj N, Gujjala R, et al. Production of high performance AA7150-1% SiC nanocomposite by novel fabrication process of ultrasonication assisted stir casting. *Ultrason Sonochem.* **2019**;58(104665):104665.
- [15] Chen L, Weiss D, Morrow J, et al. A novel manufacturing route for production of high-performance metal matrix nanocomposites. *Manuf Lett.* **2013**;1(2-4):62-65.
- [16] Vijayaram T, Sulaiman S, Hamouda A, et al. Fabrication of fiber reinforced metal matrix composites by squeeze casting technology. *J Mater Process Technol.* **2006**;178(1-3):34-38.
- [17] Xavier R, S JJ. Synthesis and characterization of AA7050-TiO₂ reinforced aluminium matrix composite. *J Mech Sci Technol.* **2021**;35(11):4917-4924.
- [18] Jarzabek DM. The impact of weak interfacial bonding strength on mechanical properties of metal matrix – ceramic reinforced composites. *Compos Struct.* **2018**;201:352-362.
- [19] Tang Z, Zhang J, Cheng Z, et al. Synthesis of nanosized rutile TiO₂ powder at low temperature. *Mater Chem Phys.* **2003**;77(2):314-317.
- [20] Ramachandran K, Carmine Z, Yoshida K, et al. Experimental investigation and mathematical modelling of water vapour corrosion of Ti₃SiC₂ and Ti₂AlC ceramics and their mechanical behaviour. *J Eur Ceram Soc.* **2021**;41(9):4761-4773.
- [21] Ceschini L, Morriab A, Toschi S, Seifeddine S, et al. “Room and high temperature fatigue behaviour of the A354 and C355 (Al-si-cu-mg) alloys: role of microstructure and heat treatment. *Mater Sci Eng A.* **2016**;653:129-138.
- [22] Chawla N, Habel U, Shen Y-L, et al. The effect of matrix microstructure on the tensile and fatigue. *Metall Mater Trans A.* **2000**;31A(A):531-540.
- [23] Yigezu B, Jha P, Mahapatra M. The key attributes of synthesizing ceramic particulate reinforced Al-based matrix composites through stir casting process: a review. *Mater Manuf Processes.* **2013**;28(9):969-979.
- [24] Rao PN, Singh D, Brokmeier HG, et al. Effect of ageing on tensile behavior of ultrafine grained Al 6061 alloy. *Mater Sci Eng A.* **2015**;641:391-401.
- [25] Arunkumar T, Anand G, Subbiah R, et al. Effect Of multiwalled carbon nanotubes on improvement of fracture toughness of spark-plasma-sintered yttria-stabilized zirconia nanocomposites. *J Mater Eng Perform.* **2021**;30:3925-3933.
- [26] Strawbridge A, Hou PY. The role of reactive elements in oxide scale adhesion. *Mater High Temp.* **2016**;12(2-3):177-181.
- [27] Gates N, Fatemi A. Notch deformation and stress gradient effects in multiaxial fatigue. *Theor Appl Fract Mech.* **2016**;84:3-25.
- [28] Majima T, Furukawa A. Stress and strain distributions in plastically deformed notched bars. *J Strain Anal Eng Des.* **1990**;25(2):67-74.
- [29] Adriano V, Martinez J, Ferreira J, et al. The influence of the fatigue process zone size of fatigue life estimations performed on aluminum wires containing geometric discontinuities using the theory of critical distances. *Theor Appl Fract Mech.* **2018**;97(1):265-278.
- [30] Emanuelli L, Molinari A, Facchini L, et al. Effect of heat treatment temperature and turning residual stress on the plain and notch fatigue strength of Ti-6Al-4V additively manufactured via laser powder bed fusion. *Int J Fatigue.* **2022**;162:1-12.
- [31] Valmikanathan P, Ravi K, P S-J, et al. The effects of nanoparticle addition on SiC and AlN powder-polymer mixtures: packing and flow behavior. *Int J Refract Metals Hard Mater.* **2013**;36:183-190.
- [32] Askarinejad S, Rahbar N, Sabelkin V, et al. Mechanical behavior of a notched oxide/oxide ceramic matrix composite in combustion environment: experiments and simulations. *Compos Struct.* **2015**;127:77-86.