



# Electron density fluctuation measurements using a multichannel microwave interferometer in GAMMA 10

著者	Yoshikawa M., Shima Y., Matsumoto T., Nakahara A., Yanagi N., Itakura A., Hojo H., Kobayashi T., Matama K., Tatematsu Y., Imai T., Kohagura J., Hirata M., Nakashima Y., Cho T.
journal or publication title	Review of scientific instruments
volume	77
number	10
page range	906-908
year	2006-09
権利	(C) American Institute of Physics
URL	<a href="http://hdl.handle.net/2241/101641">http://hdl.handle.net/2241/101641</a>

doi: 10.1063/1.2227445

## Electron density fluctuation measurements using a multichannel microwave interferometer in GAMMA 10

M. Yoshikawa,<sup>a)</sup> Y. Shima, T. Matsumoto, A. Nakahara, N. Yanagi, A. Itakura, H. Hojo, T. Kobayashi, K. Matama, Y. Tatematsu, T. Imai, J. Kohagura, M. Hirata, Y. Nakashima, and T. Cho

*Plasma Research Center, University of Tsukuba, Tsukuba, Ibaraki 305-8577, Japan*

(Received 2 May 2006; presented on 9 May 2006; accepted 16 June 2006; published online 27 September 2006)

Measurement of fluctuation in plasma is important for studying the improvement in plasma confinement by the formation of the plasma confinement potential. The density fluctuation is observed by microwaves by methods such as interferometry, reflectometry and Fraunhofer diffraction method. We have constructed a new multichannel microwave interferometer to measure the plasma density and fluctuation radial profiles in a single plasma shot. We successfully measured the time-dependent density and line-integrated density fluctuation radial profiles in a single plasma shot using the multichannel microwave interferometer. Thus, we have developed a useful tool for studying the improvement in plasma confinement by the formation of plasma confinement potential. © 2006 American Institute of Physics. [DOI: [10.1063/1.2227445](https://doi.org/10.1063/1.2227445)]

### I. INTRODUCTION

The tandem mirror GAMMA 10 utilizes an electron cyclotron resonance heating (ECRH) for forming a confinement potential.<sup>1-7</sup> The measurement of the fluctuation in the plasma is important for studying the improvement in plasma confinement by the formation of a plasma confinement potential.<sup>1,2,8</sup> Density fluctuation is observed using microwaves, such as interferometer,<sup>8-11</sup> reflectometry<sup>8</sup> and Fraunhofer diffraction (FD) methods,<sup>9,10</sup> and electrostatic probes.<sup>11</sup> Ultrashort-pulse reflectometry has an advantage of detecting fluctuation locally. The wave number can be obtained by the FD method. Electrostatic probes are used in the edge plasma region. We have constructed a new multichannel microwave interferometer to measure the plasma density profile and the density fluctuation profile in a single plasma shot. The fluctuation is excited in the hot-ion mode plasma.<sup>1-4</sup> When the ECRH is applied, the electron density in the central cell increases gradually due to an improvement in the plasma confinement potential. The intensity of the density fluctuation is suppressed when good plasma confinement is achieved in a good plasma condition. At this point, radial potential distribution, i.e., the electric field, varies along with the formation of plug potential. From this behavior, it is concluded that the fluctuation is closely related to the potential formation and confinement improvement. This article describes the initial results of the density and line-integrated density fluctuation measurements in the central cell of the tandem mirror GAMMA 10 by using the newly constructed multichannel interferometer.

### II. EXPERIMENTAL APPARATUS

GAMMA 10 is an effectively axisymmetrized minimum- $B$  anchored tandem mirror with a thermal barrier at both end

mirrors. This device consists of an axisymmetric central mirror cell, anchor cells with minimum- $B$  configuration, and plug/barrier cells with axisymmetric mirrors. The length of the central cell is 6 m, and both ends of the central cell are connected to the anchor cells, whose length is 4.8 m, through the mirror throat regions. The length of the plug/barrier cell is 2.5 m. In the tandem mirror GAMMA 10, plasma confinement is achieved by not only a magnetic mirror configuration but also a high potential at both end regions. The main plasma confined in GAMMA 10 is produced and heated by ion cyclotron range of frequency (ICRF) power deposition. The potentials at the plug/barrier region are produced by ECRH. In addition, neutral beam injection (NBI) is utilized at the plug/barrier cell to produce a sloshing ion. They cause an increase in the density in the central cell. The density and other fluctuations are excited in the central cell at several kilohertz. The typical electron density, electron temperature, and ion temperature are approximately  $2 \times 10^{12} \text{ cm}^{-3}$ , 80 eV, and 5 keV, respectively. There are several methods to observe the density fluctuation such as by using microwave interferometers, by microwave reflectometry and FD methods, and electrostatic probes. Each method has its own merits and demerits. We have constructed a multichannel microwave interferometer to observe the line-integrated density radial and the radial fluctuation profiles in a single plasma shot.

Millimeter-wave diagnostics have been developed to measure the density and their fluctuation components in magnetically confined plasmas. A single channel microwave interferometer with movable horns has been installed and is operational in the central cell of the GAMMA 10 tandem mirror. We have developed a multichannel microwave interferometer and applied it to measure the central cell plasma. The schematic diagram of the multichannel microwave interferometer system is shown in Fig. 1. It is designed using a Gaussian-beam propagation theory and a ray tracing code.

<sup>a)</sup>Electronic mail: [yosikawa@prc.tsukuba.ac.jp](mailto:yosikawa@prc.tsukuba.ac.jp)

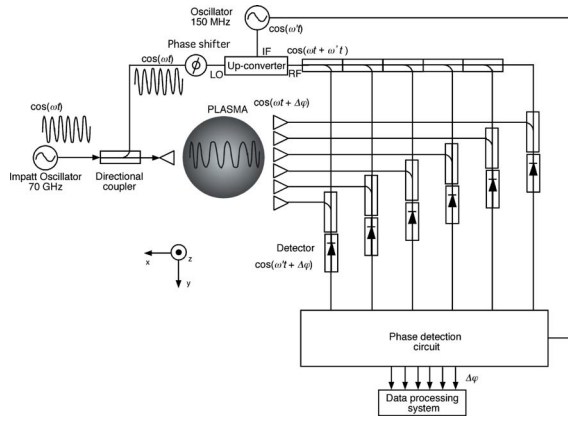

FIG. 1. Schematic of the multichannel microwave interferometer system.

The system is configured as a heterodyne interferometer consisting of a 70 GHz (1 W) impact ionization transit time (IMPATT) oscillator (Quinstar Technology, QIO-7030CL) and a 150 MHz oscillator (Vega Technology, VCO-132). The output of the IMPATT oscillator is divided into two microwave beams. The first is a probe beam that goes through the plasma, and the other is a reference beam that is combined with the output of a 150 MHz oscillator using an upconverter (Millitech, MUP-12-RSR). The probe microwave beam is injected into the plasma without a lens system from the upper port of GAMMA 10. The probe beam extends and is received by six horns positioned at the measuring distances of  $y=6$  cm (channel 1), 3 cm (channel 2), 1 cm (channel 3),  $-2$  cm (channel 4),  $-4$  cm (channel 5), and  $-7$  cm (channel 6) at the bottom, outside the port of GAMMA 10. The spatial resolution of the system is approximately 3 cm. The received signals  $\cos(\omega t + \Delta\varphi)$  in each channel, where  $\Delta\varphi$  is the phase change due to the plasma density, and the combined reference signal  $\cos(\omega t + \omega' t)$  are combined with a directional coupler and fed to a phase detection circuit (R&K, PSD-1G) through the detectors with low pass filters. The outputs of the phase detection circuits yield the dc signal components of  $\sin \Delta\varphi$  and  $\cos \Delta\varphi$ . The line-integrated electron density of each position is calculated numerically by considering the arctan( $\sin \Delta\varphi / \cos \Delta\varphi$ ). The phase change  $\Delta\varphi$  is determined by the electron density,

$$\Delta\varphi = \frac{\pi}{\lambda n_c} \int_l n_e(r) dx. \quad (1)$$

Here,  $n_c$  is the cutoff density, which is determined as  $n_c = \epsilon_0 m_e \omega^2 / e^2$ , and  $n_e(r)$  is the electron density at plasma radius  $r$ . The Abel inversion technique is then used for obtaining the electron density radial profile,

$$n_e(r) = -\frac{\lambda n_c}{\pi^2} \int_r^a \frac{d(\Delta\varphi)}{dy} \frac{dy}{(y^2 - r^2)^{1/2}}. \quad (2)$$

We combined the data of the movable interferometer at the measured position of  $y=15$  cm and those of the multichannel interferometer in order to obtain the plasma radial density profiles with a single plasma shot. When we use the movable interferometer, we have to use around ten plasma shots to obtain the plasma radial density profile.

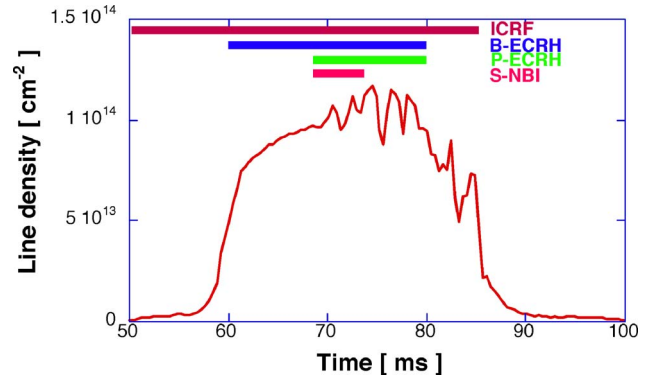

FIG. 2. Time variation of line-integrated density measured at the center of the plasma using the movable interferometer.

### III. DENSITY PROFILE AND FLUCTUATION MEASUREMENTS

The plasma is produced at 50.5 ms and sustained by ICRF. The barrier ECRH is then applied between 60 and 80 ms to create a thermal barrier potential, and plug ECRH is applied between 68 and 80 ms to create confining potentials. NBI is injected between 68 and 72 ms. The density in the central cell is measured by the movable interferometer and the newly installed multichannel microwave interferometer in a single plasma shot. Figure 2 shows the time variation in line-integrated density at the center of the plasma,  $y=0$  cm, measured by the movable interferometer with the heating sequence. Figures 3 and 4 show the line-integrated electron density radial profiles on the central cell (a) and time-dependent Abel-transformed electron density profiles (b), respectively. Figures 3(a) and 4(a) show the line-integrated electron density radial profiles before applying

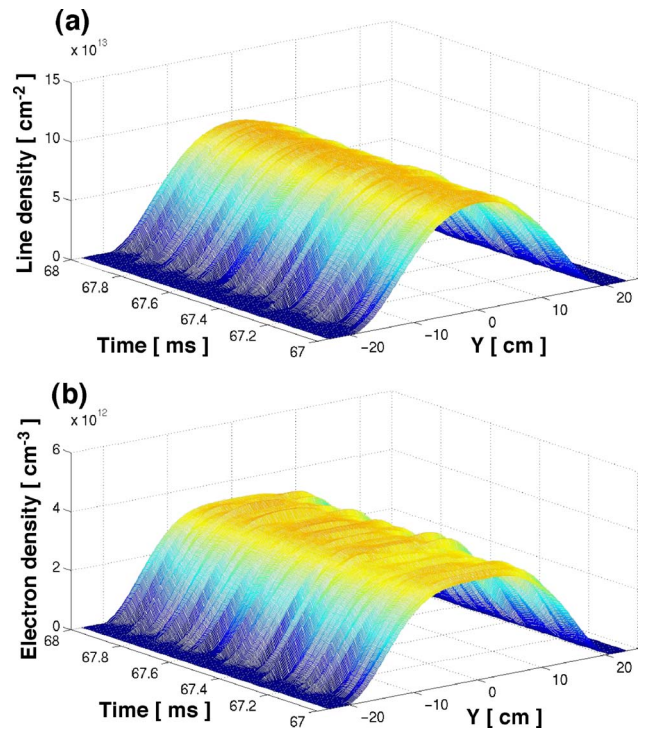

FIG. 3. Time-dependent line-integrated density radial profile (a) and electron density profile (b) before plug ECRH.

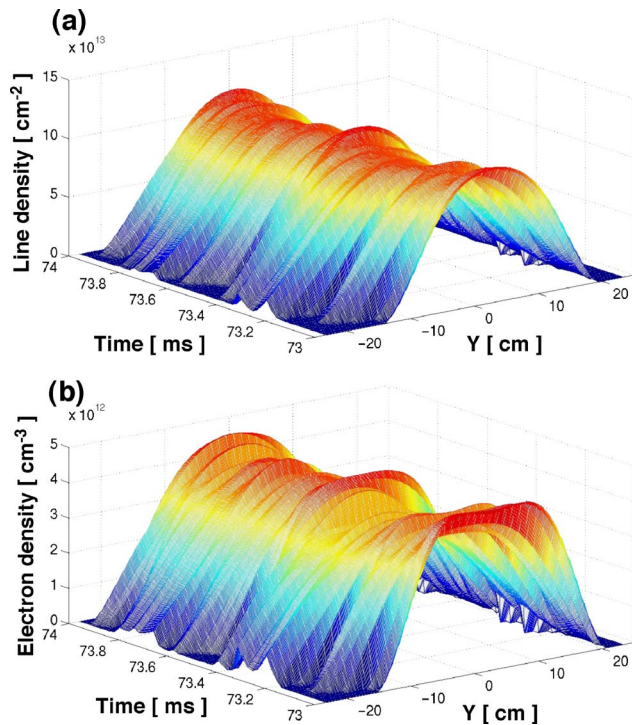

FIG. 4. Time-dependent line-integrated density radial profile (a) and electron density profile (b) during plug ECRH.

plug ECRH at 67–68 ms. Figures 3(b) and 4(b) show the electron density profiles while applying plug ECRH at 73–74 ms. The density on the plasma axis is  $2.9 \times 10^{12} \text{ cm}^{-3}$  without the plug ECRH and  $4.5 \times 10^{12} \text{ cm}^{-3}$  with the plug ECRH. The electron density peaked during the plug ECRH due to the formation of the confining potential in the plug/barrier region. The density fluctuation is clearly observed in Fig. 4(b). An error of approximately 20% is included in this measurement when compared with the results of the shot-by-shot movable interferometer measurement method.

Figure 5 displays the fast-Fourier-transformed (FFT) frequency spectra of the line-integrated densities measured at each position using the multichannel interferometer. Figures 5(a) and 5(b) show the FFT spectra before and during the plug ECRH, respectively. A strong peak is not observed in the spectrum on each channel before the plug ECRH. During the plug ECRH, the spectrum of each channel shows that the increase in the fluctuation is around two times greater than that before the plug ECRH, particularly at the higher frequency range. The coherent mode is near 4 kHz and its second order is observed. This coherent mode is due to  $E \times B$  drift.

#### IV. DISCUSSION

We have constructed a new multichannel microwave interferometer to observe the radial plasma density and density fluctuation. We can successfully obtain the time-dependent plasma density radial distribution using the Abel-transform technique for output signals of the multichannel microwave interferometer and the movable interferometer. Moreover, we

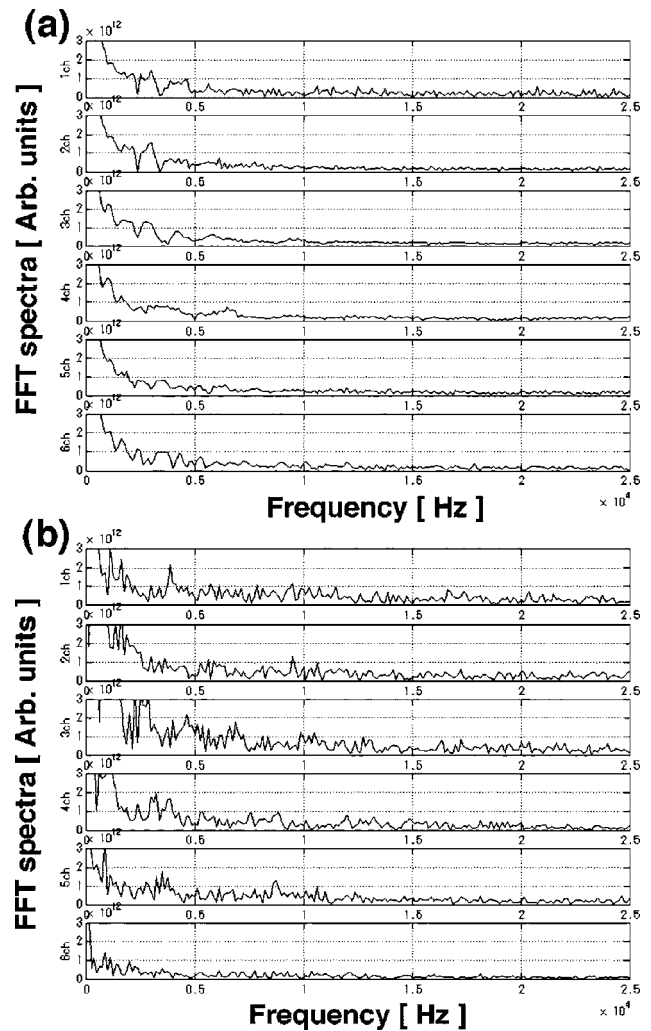

FIG. 5. FFT spectra of each channel before plug ECRH (a) and during plug ECRH (b).

can obtain the radial line-integrated density fluctuation spectra after the FFT signals for each channel. We thus prepared one of the diagnostic tools for studying the improvement in the plasma confinement.

#### ACKNOWLEDGMENTS

The authors would like to thank the members of the GAMMA 10 group at the University of Tsukuba for their collaboration. This work was partly supported by the Ministry of Education, Culture, Sports, Science and Technology and a Grant-in-Aid for Scientific Research in Priority Areas (No. 16082203).

- <sup>1</sup>T. Cho *et al.*, Phys. Rev. Lett. **94**, 085002 (2005).
- <sup>2</sup>T. Cho *et al.*, Nucl. Fusion **45**, 1650 (2005).
- <sup>3</sup>T. Cho *et al.*, Phys. Rev. Lett. **64**, 1373 (1990).
- <sup>4</sup>T. Cho *et al.*, Phys. Rev. A **45**, 2532 (1992).
- <sup>5</sup>M. Yoshikawa *et al.*, Fusion Sci. Technol. **43**, 189 (2003).
- <sup>6</sup>M. Yoshikawa *et al.*, Fusion Sci. Technol. **39**, 1553 (2001).
- <sup>7</sup>M. Yoshikawa *et al.*, Fusion Sci. Technol. **35**, 273 (1999).
- <sup>8</sup>A. Itakura *et al.*, J. Plasma Fusion Res. **76**, 1198 (2000).
- <sup>9</sup>A. Mase *et al.*, Phys. Rev. Lett. **64**, 2281 (1990).
- <sup>10</sup>A. Itakura *et al.*, Fusion Sci. Technol. **47**, 300 (2005).
- <sup>11</sup>H. Higaki *et al.*, Rev. Sci. Instrum. **75**, 4085 (2004).