

Modeling optimization for a typical VOCs thermal conversion process

Wencai Zhuo^{1,2}, Baiqian Dai^{2,3}, Kaibing Zhang^{1,2}, Yunpeng Yu³, Zhicheng Zhang⁵, Hailiang Zhou⁵, Bin Zhou^{1,*}

¹ School of Energy and Environment, Southeast University, Nanjing 210042, China; zzhouwencai@163.com (W.Z.); kzha0079@student.monash.edu (K.Z.)

² Department of Chemical Engineering, Southeast-Monash Joint Graduate School, SIP, Suzhou 215123, China

³ Department of Chemical & Biological Engineering, Monash University, Melbourne, VIC 3800, Australia; bai-qian.dai@monash.edu (B.D.)

⁴ Suzhou Industrial Park Monash Institute of Science and Technology, Suzhou 215127, China; 1057153525@qq.com

⁵ Suzhou Beyond Environmental Protection Technology Co., Ltd., Suzhou 215200, China; 13837143778@163.com (Z.Z.); 13401500707@139.com (H.Z.)

Abstract: Aiming at the current environmental problems, the thermal oxidation treatment for industrial VOCs emission is a common and effective measure. This paper studies on the optimization effect of one optimization method for direct VOCs thermal oxidation of a color aluminum spraying production line based on Aspen-Plus. According to the direct VOCs thermal oxidation process with a 30000 m³/h circulating air volume, propose the flue gas reflux and coating room drainage technology. Use the second law of thermodynamics, and the exergy flow analysis shows the methane consumption could be reduced 12%. Carbon emissions also decreased significantly, with 3.42% reduction. These findings are practical for industrial production cost saving and environmental protection problems solving.

1. Introduction

Volatile organic compounds (VOCs) generally refer to aromatic hydrocarbons, higher alkanes, olefins and nitrogen-containing sulfur compounds [1]. Most of these substances pollute the air environment and even cause serious harm to human health [2, 3]. In recent years, carbon emissions are also receiving increasing attention [4]. Policies on industrial VOCs emissions are also becoming more and more stringent [5]. Therefore, VOCs treatment is of great significance to industrial development and environmental protection.

VOCs of industrial waste gas is usually characterized by large amounts and low concentration. Thermal oxidation technology has become the first choice due to its low cost and high processing efficiency [6]. The combustion treatment rate of toluene, chloromethane, hydrocarbons, and other VOCs can be maintained at more than 95% [7]. Thermal oxidation technology can be divided into direct thermal oxidation, regenerative thermal oxidation, and catalytic thermal oxidation. Thermal oxidation technology needs adding accelerants to meet the ignition and combustion maintenance, because of low concentration of combustible components, and usually using methane [8, 9]. regenerative thermal oxidation technology such as two-chamber and three-chamber direction improves the energy utilization efficiency of the incinerator chamber [10, 11]. The use of precious metal or Cu, Mn, and other metal oxides as catalyst, can reduce the reaction temperature, become flameless combustion [12,

13]. Most factories choose the direct thermal oxidation and build an incinerator to directly incinerate the exhaust gas containing VOCs. Although the structure is simple, the energy utilization efficiency is low. An aluminum spraying factory chooses the direct combustion method and uses the three-stage heat exchanger to utilize the preheating in China [14]. It has the problems of high energy consumption and large carbon emission.

The technology of flue gas recovery and utilization is widely used in the research field of boiler [15]. Flue gas recirculation technology can reduce the energy consumption of coal-fired boilers [16]. The adsorption of VOCs by the zeolite runner can also change the concentration of industrial source exhaust gas [17]. Researchers have studied the adsorption VOCs in high concentration through experimental verification and Aspen-Plus software simulation [18, 19]. For direct thermal oxidation technology, the system structure can be changed by flue gas drainage and pre-treatment before waster gas input to be optimized.

In this paper, one method is proposed for the direct thermal oxidation for VOCs in the color aluminum spraying plant to achieve the purpose of improving energy consumption and reducing carbon emission.

2. Methodology

2.1. Direct thermal oxidation process modeling

The modeling data comes from the operation parameters

* Correspondence: zhoubinde@seu.edu.cn (B.Z.)

of the production line of a color aluminum spraying plant in Anhui, China. The production and operation air volume of the system is 22,000m³/h, and the circulating air volume is 30,000m³/h. Circulating air refers to the supply air volume required for internal circulation of the drying oven in the spraying plant. The operation of the system can be understood as the VOCs waste gas provided by the coating room and the drying oven, which is heated by the high, neutral, and low temperature three-stage preheater and

burned together with the auxiliary gas methane in the furnace. The drying oven is a unique system step in the color aluminum spraying factory. It is mainly used to dry the aluminum sheet sprayed with paint. It requires a temperature environment of about 450 °C, which will lead to the volatilization of massive VOCs. Paint raw materials are stored in the coating room, and little VOCs are volatilized in a low temperature environment. **Figure 1** shows the flowsheet of direct thermal oxidation process.

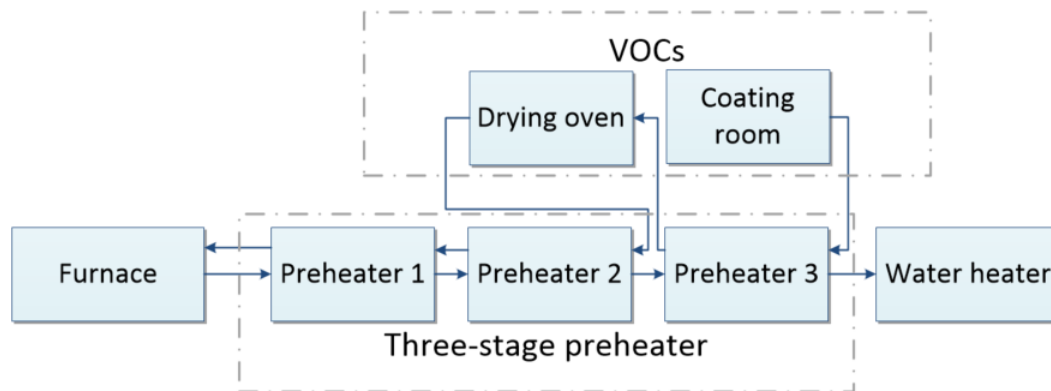

Figure 1 Flowsheet of direct thermal oxidation process

Table 1 shows the parameters of simulation in direct thermal oxidation. There are two sources of VOCs, one is from the drying oven which has high temperature and concentration, the other is from the coating room which

has low temperature and concentration. The methane consumption for stable operation of the system is about 180m³/h.

Table 1. Feed parameters of direct thermal oxidation

	Parameter	Value
Drying oven inlet	VOCs concentration (mg/m ³)	5000
	VOCs temperature (°C)	300
Coating room inlet	VOCs concentration (mg/m ³)	100
	Air consumption (m ³ /h)	2000
	VOCs temperature (°C)	25
Combustion inlet	Methane consumption (m ³ /h)	100
	Air consumption (m ³ /h)	3000
	Inlet temperature (°C)	25
VOCs-carried air volume flow (m ³ /h)		22000
Circulating air volume flow (m ³ /h)		30000
Water consumption (m ³ /h)		10

Table 2 shows the temperature of furnace and other heat exchangers. The combustion temperature of the furnace is 750°C. After circulating in the drying oven, the hot air mixed with two sources of VOCs is heated from

250 °C to 544 °C by the preheater 1 and 2, and sent to the furnace. The exhaust gas temperature is stable at around 140 °C.

Table 2. Temperature parameters of direct thermal oxidation

	Preheater 1	Preheater 2	Preheater 3	Water heater
Heat flow (°C)	750→621	621→488	488→433	433→140
Cold flow (°C)	421→572	264→421	25→185	25→72

2.2. Flue gas reflux and coating room drainage technology modeling

The flue gas reflux technology means part of the flue gas before the water heater is controlled by the valve to

enter the furnace. Since the heat of this part of the flue gas can supply the demand of the furnace and balance the energy of the inlet and outlet of the furnace, the consumption of methane to support combustion can be appropriately reduced, to achieve higher economy. The

coating room drainage technology means the air carrying little VOCs entering the low temperature preheater is controlled by a valve to replace the supporting air for methane combustion, to achieve the purpose of energy

saving and emission reduction from the perspective of reducing furnace load. The modeling of the two methods in Aspen-Plus is shown in **Figure 2**.

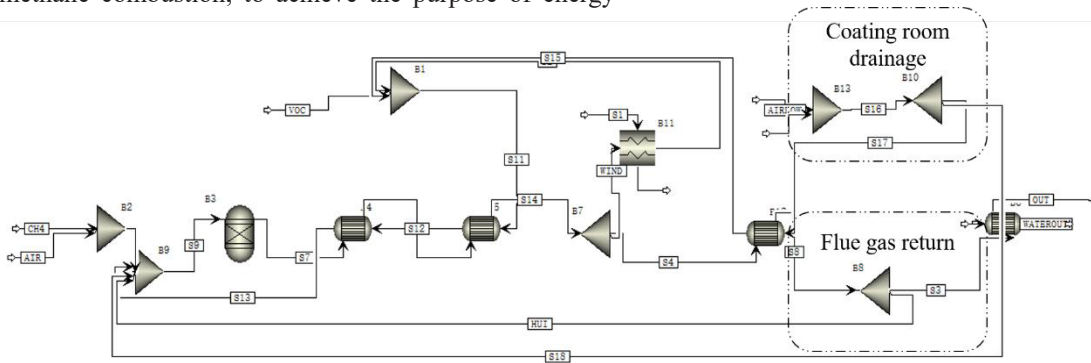

Figure 2 Model diagram of flue gas reflux and coating room drainage technology

The parameters of feed and heat exchangers are the same as those of direct thermal oxidation type.

2.3. Exergy analysis method

The exergy analysis is a numerical calculation based on the thermodynamic parameters of the inlet and outlet of different components for this system, including the physical exergy and chemical exergy of Formula (1)[20].

$$E = E_{ph} + E_{ch} \quad (1)$$

Where E_{ph} is physical exergy which is equal to enthalpy difference and entropy difference under corresponding working conditions and standard conditions, as shown in Formula (2).

$$E_{ph} = (H - H_0) - T_0 (S - S_0) \quad (2)$$

E_{ch} is chemical exergy which is related to chemical composition of each mixture, as shown in Formula (3).

$$E_{ch} = m \left[\sum x_i e_i + RT_0 \sum (x_i \ln x_i) \right] \quad (3)$$

Where m is molar flow, x_i is molar fraction of each component, and e_i is standard chemical exergy of each component.

3. Results and Discussion

3.1. Sensitivity analysis of flue gas and coating room drainage technology

The reflux rates of Case 2 were changed as independent variables to test whether the model dependent variables were reasonable. Methane consumption, combustion-supporting air amount and CO₂ emissions were set as dependent variables. **Figure 3** shows the results of that.

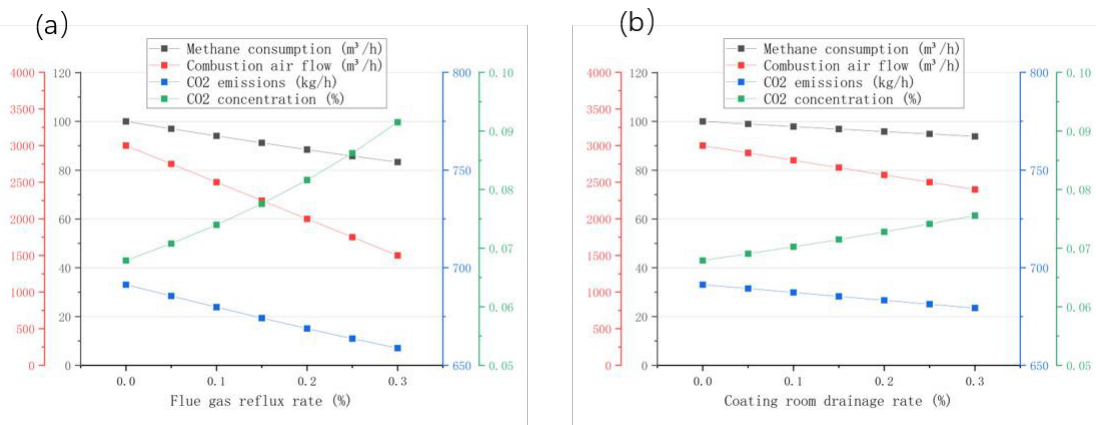

Figure 3 Sensitivity of reflux and drainage rates: (a) Flue gas reflux; (b) Coating room drainage

drainage rate is set to 0.3. With the reflux and drainage rate increasing, the methane consumption decreases, the CO₂ emissions decrease. The heat of flue gas can supply the demand of the furnace, balance the energy at the furnace inlet and outlet. Air carrying a small number of VOCs replaces the air supporting combustion gas to reduce furnace load. To meet the requirements of hot air system heating aluminum sheet, the combustion air quantity must be around 2500 m³/h. Flue gas reflux rate is set to 0.1, and coating room

3.2. Exergy analysis

After calculation, the exergy flow results of direct VOCs thermal oxidation and flue gas reflux and coating room drainage technology systems are shown in **Figure 4** and **Figure 5**.

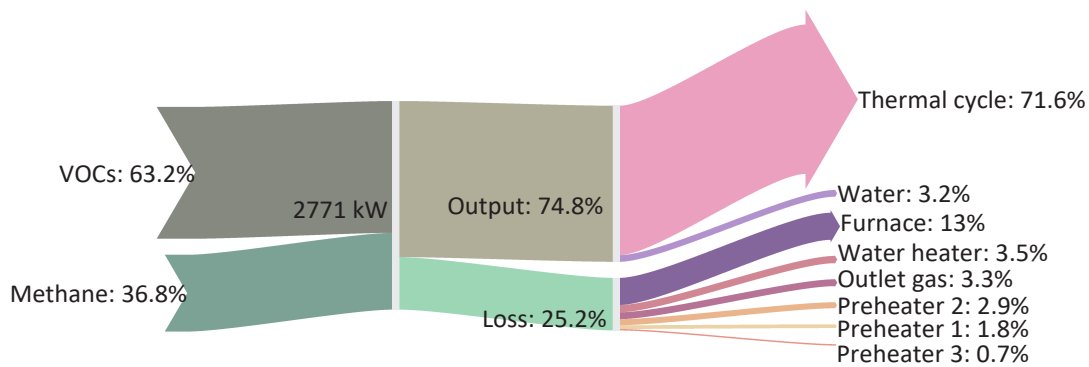

Figure 4 Exergy flow diagram of direct VOCs thermal oxidation process

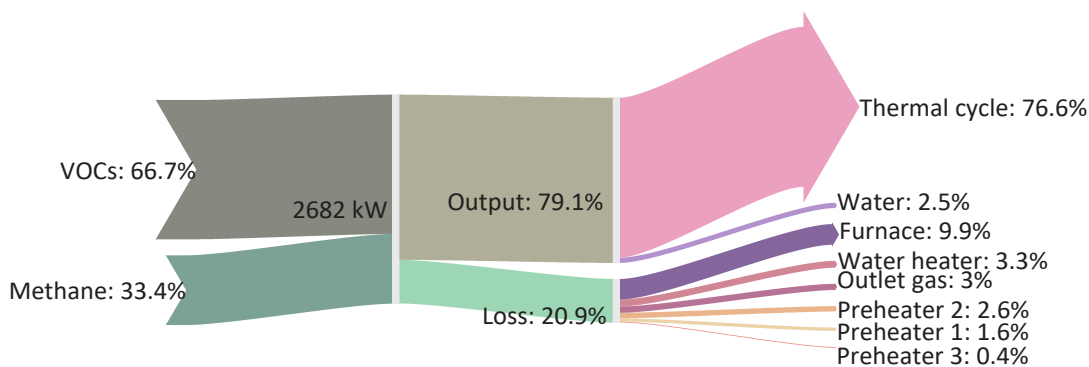

Figure 5 Exergy flow diagram of flue gas reflux and coating room drainage technology process

The optimization method is to set the flue gas reflux rate of 0.1 and the coating room drainage rate of 0.3, to provide heat recovery for furnace combustion and reduce the supporting air volume for methane, reducing the consumption of methane to 88m³/ h. To meet the heat supply required by the oven, its proportion increases from 71.6% to 76.6% as the input energy of the system decreases, while the methane saving rate is 12%. The exergy loss also decreased from 25.2% to 20.9%, of which the percentage of furnace exergy loss decreased most,

from 13% to 9.9%.

3.3. Carbon emission analysis

For the color aluminum spraying production line, due to the hot air demand of the oven, the amount of combustion air is guaranteed to be excessive, and the carbon in VOCs and methane is completely burned. Therefore, the carbon emission analysis mainly focuses on CO₂.

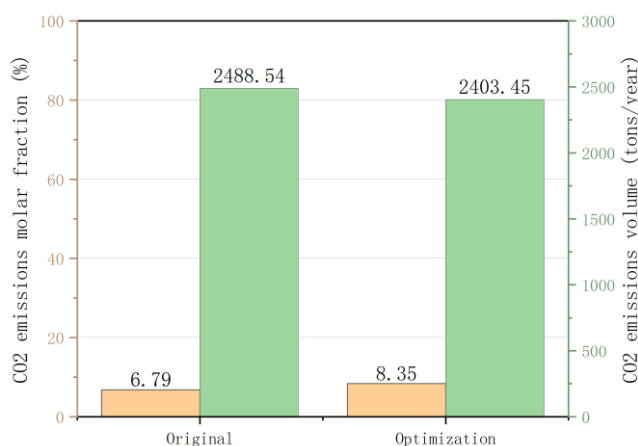

Figure 6 Carbon emission of two cases

As shown in **Figure 6**, the optimization methods have significantly CO₂ emissions reduction effect, and reduce CO₂ emissions by 85.09 tons/year, accounting for 3.42%.

4. Conclusions

VOCs thermal conversion is a common industrial VOCs processing technology. One optimization method is provided for the direct combustion method in this article. Use flue gas reflux and coating room drainage. The energy demand of hot air circulation is met, the proportion of energy utilization is increased from 71.6% to 76.6%, and the methane consumption is reduced to 88 m³/h with 12% reduction. Have significantly CO₂ emissions reduction effect, and reduce CO₂ emissions by 85.09 tons/year.

References

1. Y. Wang *et al.*, "Volatile organic compounds (VOC) emissions control in iron ore sintering process: Recent progress and future development," *Chemical engineering journal (Lausanne, Switzerland : 1996)*, vol. 448, p. 137601, 2022.
2. R. Atkinson, "Atmospheric chemistry of VOCs and NO_x," *Atmospheric environment (1994)*, vol. 34, no. 12-14, pp. 2063-2101, 2000.
3. M. L. Hatfield and K. E. H. Hartz, "Secondary organic aerosol from biogenic volatile organic compound mixtures," *Atmospheric Environment*, vol. 45, no. 13, 2011.
4. B. Jie, W. H. Lu, J. Zhao, and X. T. Bi, "Greenhouses for CO₂ Sequestration from Atmosphere," *Carbon Resources Conversion*, vol. 1, pp. 183-190, 2018.
5. S. Sultana, A. Vandenbroucke, C. Leys, N. De Geyter, and R. Morent, "Abatement of VOCs with Alternate Adsorption and Plasma-Assisted Regeneration: A Review," *Catalysts*, vol. 5, no. 2, pp. 718-746, 2015.
6. Y. Goldshmid, "Destroying organic wastes: Thermal oxidizer basics," *Chemical engineering progress*, vol. 101, no. 5, pp. 40-47, 2005.
7. W. Jian and L. Zhang, "Progress in the Treatment of Volatile Organic Waste Gas," *Guangdong Chemical Industry*, 2018.
8. N. Sheng, Z. Wei, M. Chen, Y. Sun, and X. Han, "Research progress in treatment technology for exhaust gas from spray paint process," *Chemical Industry and Engineering Progress*, 2017.
9. W. Luo, W. Dai, D. Li, H. Xiao, and T. Pan, "Research Progress of Common Treatment Technology of VOCs for Industrial Sources," *Guangdong Chemical Industry*, 2017.
10. J. Liu and Z. Peng, "Experimental and Numerical Investigations into Temperature Distributions and VOC Conversion Rate of RTO," *IOP Conf. Ser.: Earth Environ. Sci.*, vol. 943, no. 1, p. 12014, 2021.
11. G. Wenguang, Z. Jigang, Y. Dongling, S. Rongfeng, and P. Li, "Application Study on Three-Bed Regenerative Thermal Oxidizers to Treat Volatile Organic Compounds," *IOP Conference Series: Earth and Environmental Science*, vol. 170, 2018.
12. T. Gan *et al.*, "Pt/Al₂O₃ with ultralow Pt-loading catalyze toluene oxidation: Promotional synergistic effect of Pt nanoparticles and Al₂O₃ support," *Applied Catalysis B: Environmental*, vol. 257, no. C, 2019.
13. L. Wang *et al.*, "Preparation of LaMnO₃ for catalytic combustion of vinyl chloride," *Chinese Journal of Catalysis*, vol. 38, no. 8, 2017.
14. W. Zhuo, B. Zhou, Z. Zhang, H. Zhou, and B. Dai, "Process Modeling and Exergy Analysis for a Typical VOC Thermal Conversion Plant," *Energies (Basel)*, vol. 15, no. 10, p. 3522, 2022.
15. Z. Hu, M. Li, J. Fang, and R. Zheng, "Collaborative optimization for deep peak-shaving and ultra-clean emission of coal-fired boiler using flue gas recycling technology," *Energy Sources Part A Recovery Utilization and Environmental Effects*, 2020.
16. L. Deng *et al.*, "Effects of flue gas recirculation on combustion and heat flux distribution in 660MW double-reheat tower-type boiler," *Fuel*, vol. 321, pp. 123988-, 2022.
17. M. A. Kolade, A. Kogelbauer, and E. Alpay, "Adsorptive reactor technology for VOC

- abatement," *Chemical engineering science*, vol. 64, no. 6, pp. 1167-1177, 2009.
18. H. Sui *et al.*, "A novel off-gas treatment technology to remove volatile organic contaminants with high concentration," *Industrial & Engineering Chemistry Research*, p. acs.iecr.5b02662, 2016.
 19. X. Lv, Y. Zhang, L. Li, W. Zhang, and P. Liang, "Experimental study of ethanol adsorption using a multistage bubbling fluidized bed," *Process Safety and Environmental Protection*, vol. 125, 2019.
 20. B. Dai, L. Zhang, J.-f. Cui, A. Hoadley, and L. Zhang, "Integration of pyrolysis and entrained-bed gasification for the production of chemicals from Victorian brown coal — Process simulation and exergy analysis," *Fuel Processing Technology*, vol. 155, 2017.