



Investigation of Flood Monitoring & Detection System Using IoT Application

Muhammad Syafiq Zainal¹, Norazlianie Szali^{1*}

¹College of Engineering,
Universiti Malaysia Pahang, 26600 Pekan, Pahang, MALAYSIA

*Corresponding author

DOI: <https://doi.org/10.30880/emait.2021.03.02.003>

Received 21 September 2022; Accepted 22 December 2022; Available online 31 December 2022

Abstract: This research was conducted to investigate the performance of the Flood Monitoring & Detection System applying Internet of Thing (IoT) with solar system as a backup source. A flood is a catastrophe that happens unexpectedly and unpredictably. It is a disaster that often happens every year, especially once during the monsoon season. With the development of technology nowadays, it can help people's that live in the flood risk areas daily lives become easier. Flood Monitoring and Detection technology with warning system is built to monitor and warn people living in areas a high risk for floods so that they are always prepared for floods before it happens. This project is applying the Internet of Thing (IoT) which is applying the wireless connection concept. The system is completely controlled by one of the great Microcontroller technologies, namely the Arduino Mega, this microcontroller system can be designed according to a set program. This system requires some programming part for interfacing. Ultrasonic sensor is used in this to transfer the signal into the microcontroller board for the data output signal analysis. In current world, internet is the very most important thing nowadays, it also can be applied anytime and everywhere. Users can monitor the current situation of river water level on the application. In addition, this device also constructs as a back-up energy source with the presence of solar energy, which can be longer lasting and effective compared to conventional flood detection systems.

Keywords: Arduino Mega 2560, Internet of Things (IoT), flood detection, monitoring system

1. Introduction

The flood is one of the worst natural catastrophes in Malaysia. The floods can be characterized as overflow of rivers and lakes causing or endangering damage. Floods are severe natural disasters that annually cause deaths and monetary damage [1]. According to CRED, UNISOR, in Asia, flood is the most common natural disaster happened. Fluting is caused by natural forces such as severe precipitation, high flooding and high tides, etc, and by human factors such as channel obstruction or aggravation of drainage channels, poor land use, headwaters deforestation, etc. [2]. The growth in population leads to increased urbanization, permeability and less infiltration and a higher peak flood. The serious and regular flooding caused by the changes of climate, the socio-economic disruption, populations affected, public outrages and limited funds are becoming increasingly serious problems. In developing countries, the economic effect and impact of natural disasters are greater [3]. Natural disasters could lead to significant levels of stress and other mental disorders (e.g. trauma) for the people affected [4]. The prevention and mitigation of flood losses includes structural flood control activities such as dam building or water dikes and non-structural policies such as flood prediction and notification, management of risks and flood hazards, public engagement and institutional arrangements, etc. Malaysia experiences severe floods in 2010, with negative effects on the economy and society in general in numerous states [5]. In Malaysia, the average rainfall is about 2000 mm to 3000 mm per year, making it one of the world's heavy rainfall countries [6]. Homes were flooded and people were forced to evacuate in several instances. The flow of traffic was disturbed and often lives lost due to drowning. In addition, in Malaysia most people are concern less about environmental issues, in particular, because they consider the issue a trivial problem that the district or local

*Corresponding author: azlianie@ump.edu.my

authority can address, and expect the government to be the only flood insurer in the event of floods. In order to minimize flood damage and provide early warning about flood probability, governments or authorities have established a flood delivery mechanism to speed up recovery. The delivery system usually specifies protocols for the implementation of government services for local authorities that are more reliable and efficient. The aim of preparation is to minimize residual risk by using early warning systems and action to mitigate flood disaster effects. Problems associated with flooding have developed considerably, and an effective flood impact study is required to identify and manage the problem [7]. The management of flood response is quite difficult and requires an excellent computer support system so that suitable action may be performed quickly [8].

2. Literature Review

Based on the STATISTA, the statistic of the risk index natural disaster in Malaysia show that flood disaster is the second highest natural disaster happen [9]. This natural disaster is the common thing happen compared to the others natural disaster. Every year our country suffered a big losses due damages happen from this natural disaster and also took peoples life. Generally, There are three types of river flood, flash flood and coastal floods in Malaysia [10]. These types of floods are frequently happening every year. But on this paper, we focusing on very common type of flood which is river flood and flash flood.

2.1 GSM & Web-based Flood Monitoring System

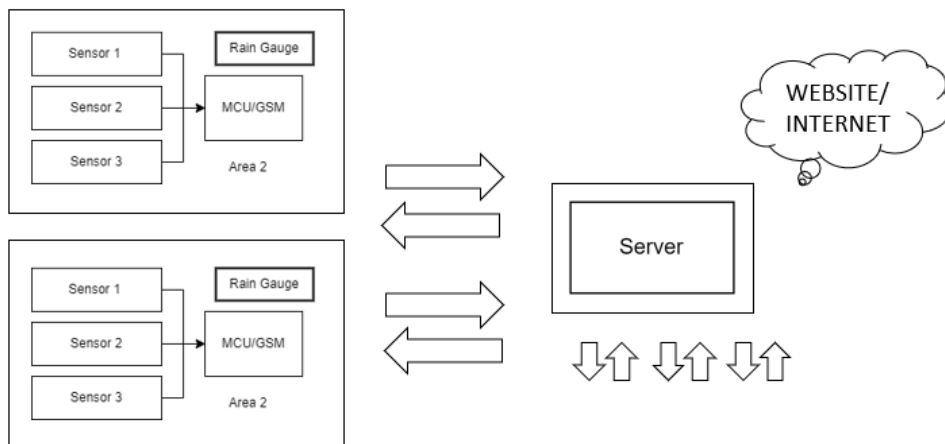

Fig. 1 - The project overall system design[11]

This project builds a prototype to detect current water levels across the river Mandulog and its neighboring areas. The physical area of the river was separated into areas with sensors. When a sensor is switched on, the output signal is sent on to an alert SMS message to the server. The output signal activates the attached GSM modem [11]. After that, a text message will automatically send to the numbers that have been stored in the database. In addition, the device then automatically uploads a warning message to social media websites such as Facebook and Twitter. As the water level rises and activates the next sensor, the process is repeated. After the level of the water hits its critical level, it will transmit to the surrounding areas a message warning. In addition, the communities will be asked by sending a message via keywords.

2.2 LabVIEW Based Flood Monitoring System

To detect and monitor the water level, this project is using LabVIEW as their main platform. This system is fully coordinated and program in LabVIEW software. LabVIEW is a forum for system design and a visual programming language development environment by the National Instruments. This software requires both the front and back-end panels. A dam and pipe tank knobs and the dam level warning indicator can be held at the front end. The back end will keep the circuit Virtual Instruments consist of the circuits. The data of the system will always flow to the data sinks from the data source [12]. In addition, this system will show the inflow and outflow rates. The sensor will be triggered the buzzer if the water level reached the danger level, and it will also be displayed on the monitor.

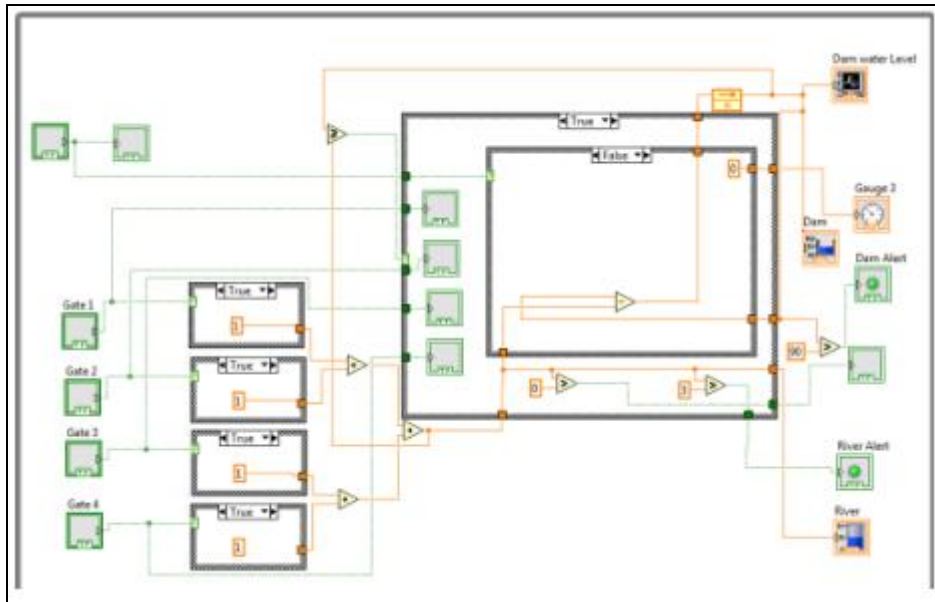

Fig. 2 - Back-end panel shows the program's system [12]

2.3 Flood Detection and Alert System based on IoT

The main unit of this system is Raspberry Pi in which this microprocessor will act as a controller to control all the components that are connected to it. Furthermore, the system are using dht11 temperature & humidity sensor, water level sensor and the raindrop sensor [13] as their input. The water level sensor will detect and measure the level of water with defined measurement as an indicator to indicate the situation of the water levels. It will run continuously to monitor the variety of water levels and will give an alert to the authorities using varieties of platform such as using Twilio platform by using GSM messaging. The system also can be monitored by using IoT platform to give a live situation of the water level. In addition, users also can use the Live Camera Feed on YouTube. Temperature and humidity can be measure on this system and the buzzer also will trigger if the water level reached the critical level and will alert the users.

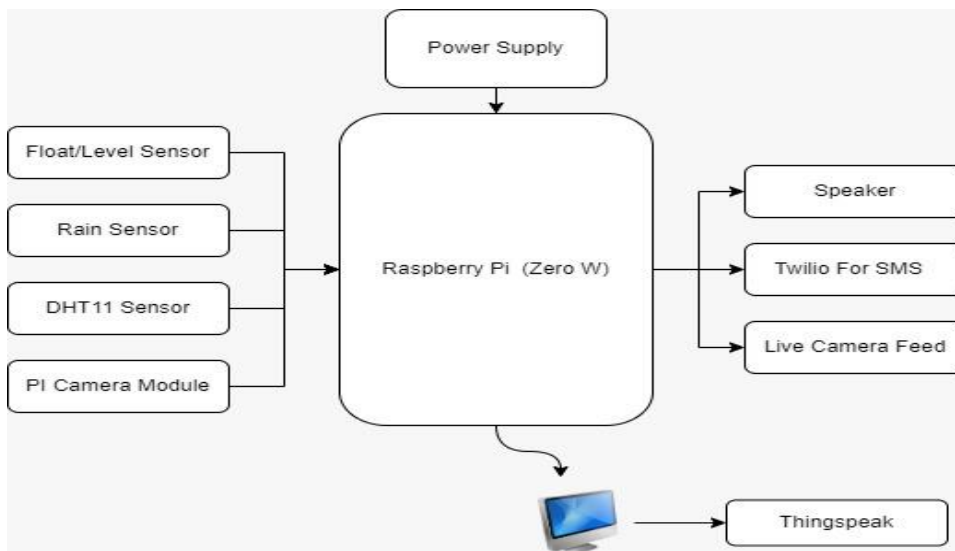

Fig. 3 - Block diagram of the system [13]

2.4 Flash Flood Warning System Using SCADA Systems

This research aimed of development of innovations to help the authorities to able in handling the incoming flood and to recover from it [14]. The current system is focusing on the SCADA systems. This model is a flash flood warning system that controlled by SCADA system. It is developed and implemented in CoDeSys platform. PLC are completely very usual with CoDeSys (Controlled Development System) [14]. They are using PLC to perform the logical operation

in which to notify the peoples that are live in flood effected area to well-prepared to save their properties and life. SCADA is system that acts as a main unit. The HMI will show the result as the interest area on the contour map.

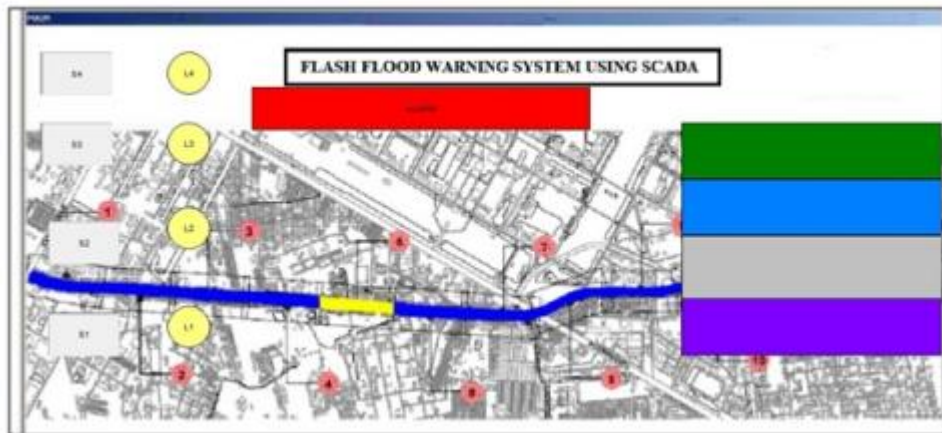

Fig. 4 - Display view of SCADA [14]

2.5 Flood Detection using Sensor Network and Notification via SMS and Public Network

In this system, the authors are using wireless sensor network in advance way. The main part of the system divided by two consists of hardware and software development. The figure 7 show the process of the system's process. PIC16F877A as main unit conduct as a controller to control all of the devices interfaced to it. Programmed codes will be installed inside PIC in C language form [15]. Components consist of water level sensor, PIC16F877A, radio frequency and Global System Communication Mobile (GSM) are the main part in this system. At the first stage, the system will detect the water level by using water level sensor, then PIC will read the data to transmit it by using radio module to the receiver. If the receiver receives the transmitted data, then in will be analyze data and display the result on monitor. After that, GSM will be triggered to send a SMS to the user to inform about the current water level situation. At the same time, system will send the details information to the flood management via Facebook and Twitter to give a warning to the communities.

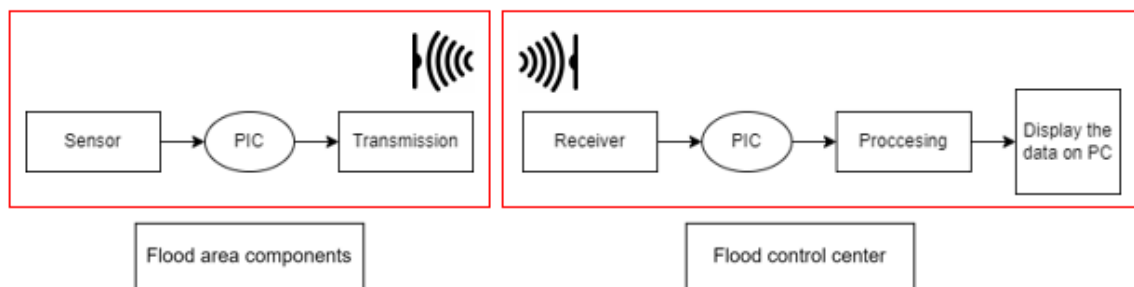

Fig. 5 - Block diagram shows the system's process [15]

3. Methodology

3.1 Flow Chart

A flowchart is a diagram that representing a workflow or process. In this flowchart, it will explain the process and the workflow of this flood monitoring system. The figure above shows the process of the system. This system will interpret the signal from the Ultrasonic sensor if the sensor triggered. The sensor will be triggered if it detects the water level of the river is exceeding the safe level. Then, it will send the signal to the Arduino. The motherboard will read the signal and transmit it via ESP32 Wi-Fi Module to the Blynk Application. From there, the user will get the warning notification about incoming flood.

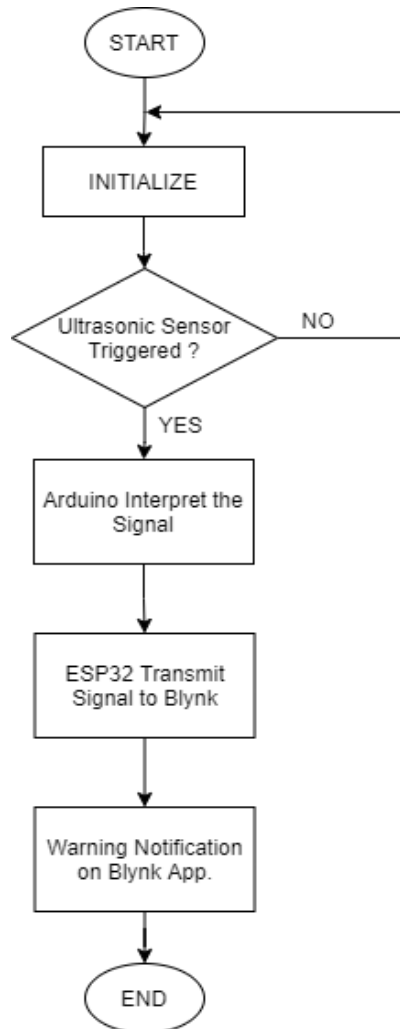

Fig. 6 - Project flowchart

3.2 Circuit Diagram

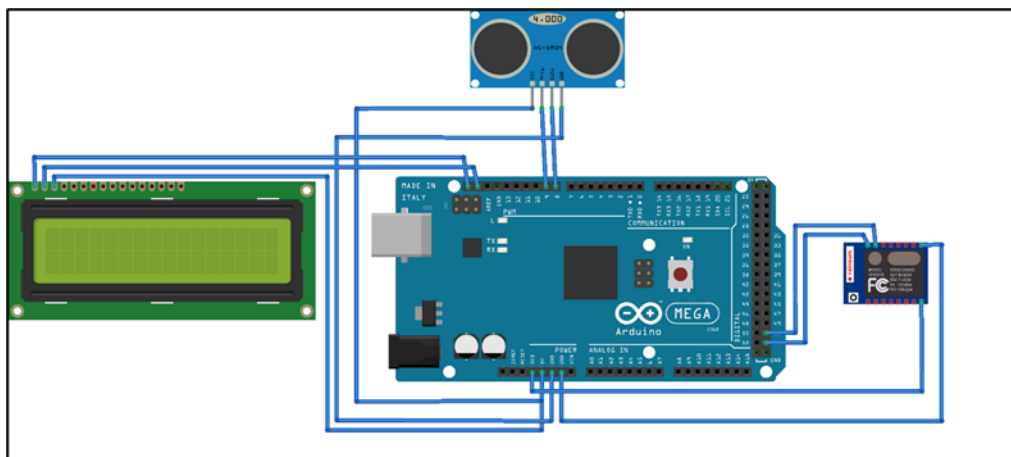

Fig. 7 - Circuit diagram in 2D

This circuit diagram will indicate the connection of the system. The main component is Arduino Mega 2560 as a controller. The sensor is connected to the Arduino Mega pin while the others connected to the Ground and Voltage Source pin. LCD Display will show all of the information needed such as current water's level and percentage of the water's level to indicate the current situation whether in a safe or danger situation. The pin of the LCD Display will

connect to the SCR and SDA pin since it is an I2C LCD Display, rest of the pin will be connected to the VCC and GND pin. The diagram also shows a ESP8266 Wi-Fi Module used to connect the system with Internet of Things (IoT).

4. List of Components

4.1 Arduino Mega 2560 Microcontroller Board

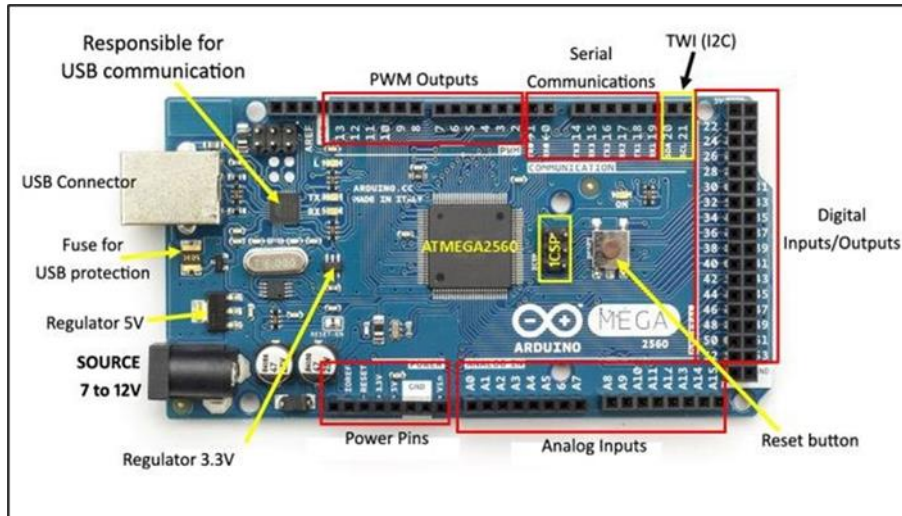

Fig. 8 - Arduino Mega 2560 board architecture[16]

Arduino Mega 2560 board based on ATmega2560 microcontroller applied. There are 54 optical input/output pins (with 15 of them being PWM outputs) and 16 analogue inputs and several power pins [17]. It includes 54 pins (of which 14 are PWM-usable), 16 analogue inputs, 4 UARTs, a 16-MHz crystal oscillator, a USB connection (a power connector), a power jack, an ICSP-header and a reset-button [18]. It was generally used to write and upload programming code to the physical board. The Arduino Mega2560 has a range of device, Arduino or other microcontrollers to communicate with. The Arduino programme contains a serial monitor which can be sent to and from the board with simple text data. The Arduino Mega2560 is designed to reset it in software running on a connected device instead of having a physical press on the reset button before the upload is made. The reset line falls long enough to reset the chip when that line is asserted (turned down). You can download code using this Arduino programme by simply pressing the upload button in the Arduino environment.

4.2 HC-SR04 Ultrasonic Sensor

For instance, the system employs ultrasonic sensors in conjunction with a microcontroller board. The ultrasonic sensor's primary function is to measure the distance between the water surface and the sensor. HC-SR04 is a ultrasonic sensor that can transmit and receive the wave signal. With an overall range of precision of up to 3 mm, this low-cost sensor gives non-contact measures between 2cm and 400cm. Each HC-SR04 module has an ultrasonic transmitter, recipient and control circuit. It all begins with at least 10 microseconds of trigger pins. In response, a sonic burst of 8 pulses at 40 kHz transmits the sensor. This 8-pulse pattern uniqueness makes the "ultrasonic signature" special in the system such that the transmitted pattern can be distinguished from the ambient ultrasonic noise. If those pulses are reflected back the Echo pin goes low as soon as the signal is received [20]. This results in a pulse with a range ranging from 150 μ S to 25 mS, according to the time it takes to get the signal.

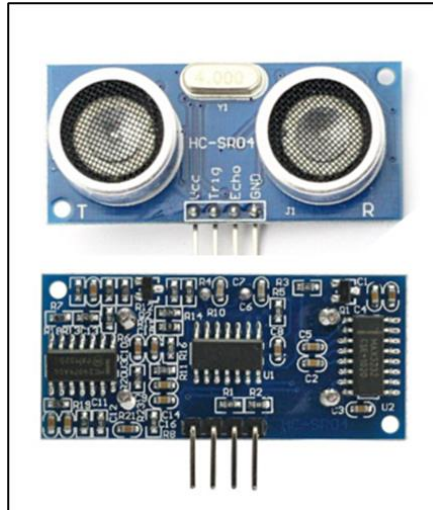

Fig. 9 - HC-SR04 ultrasonic sensor [19]

4.3 I2C 16x2 LCD Display

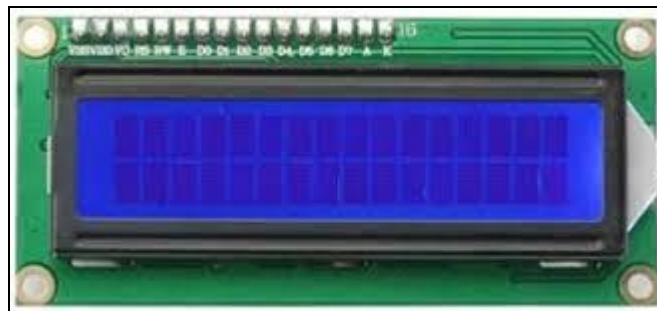

Fig. 10 - I2C 16x2 LCD display [21]

The display will deliver the information related to the system. It will show the information on it and act as a main interface of the system. The adapter is powered by a PCF8574 8-Bit I/O Expander chip and the I2C data from the Arduino is converted to the parallel data required by the LCD display using this chip [22]. Serial Data (SDA) is a pin. This line is used for transmitting and receiving data. Connect to the Arduino's SDA pin. The SCL pin is the Serial Clock pin. This is a bus master device-supplied timing signal.

4.4 ESP32 Wi-Fi Module

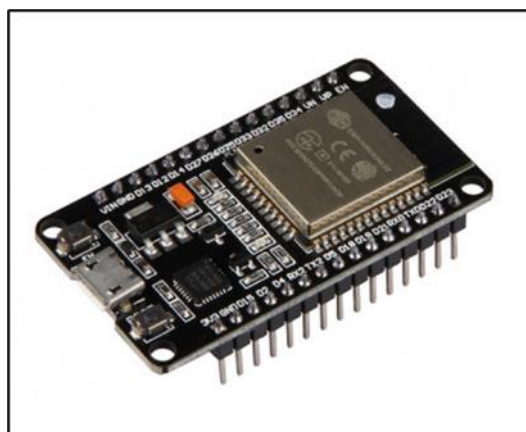

Fig. 10 - ESP32 Wi-Fi module [23]

ESP32 is a low-cost system-on-a-chip family of micro-controllers with integrated Wi-Fi and Bluetooth dual-mode. This ESP32 Series has a Tensilica Xtensa LX6 microprocessor, a dual-core and single-core system, as well as integrated antenna switches, RF baluns, amplifiers, low-noise amplifiers, filters and module power management. Figure 3.8 shows the architecture of ESP32 Wi-Fi Module. This module will be use in this project as a medium to connect with Internet of Thing (IoT) communication system.

4.5 Simulation Software: Arduino IDE, Proteus and Blynk

Arduino is a platform for open-source electronics focused on simple hardware and software. Arduino boards are able to read inputs - light on a sensor, a finger on a button, or a Twitter message - and turn it into an output - activating a motor, turning on an LED, publishing something online [24]. Many other microcontrollers and platforms for physical computing are available. Parallax Basic Stamp, MIT Handy board, BX-24 of Netmedia, Phidgets, etc. provide similar features. All these tools take on microcontroller programming specifics and bundle them into a kit that is simple to use.

The Proteus Design Suite is a proprietary software tool suite used primarily for electronic design automation [25]. The primary objective of this programme is to give diagrams and electronic prints for electronic design engineers and technicians to produce printed circuit boards. In this project, this software is mainly used to create the circuit diagram and also to run the simulation.

Blynk is a tech company that develops infrastructure for the internet of Things. Businesses of any size, from new start-ups to big enterprises, use our software to build and manage connected products [27]. For Internet of Things, Blynk was created. It can remotely monitor hardware, show data sensor, store data, view it, and do much more.

5. Hardware Development

In this part all of the components will be installed with a proper execution. It will be assembled in order to test the system whether it can run smoothly or got some errors. The ultrasonic sensor will be test frequently either it is able to transmit the data to microcontroller. This issue is essential since the sensor is the main component and very important to this system in order to achieve the objective of this prototype. The first thing that need to be done is to make sure that the system can be turn on.

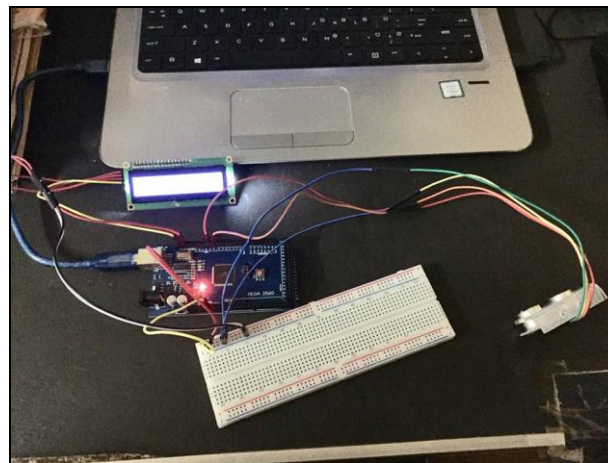

Fig. 11 - Prototype when switched on

After that, the testing begins with the ultrasonic sensor measurement. Then, the information will be converted to the percentage form and display it on the I2C LCD Display. The testing will start with three stages of the measurement. The first situation, the sensor can indicate the safe situation if the water level is below or at the normal level. This situation stated that the flood is rarely can be happen with that level of water. Then, it followed by the awareness situation is when the citizens at that area must precaution and alert because the level of the water showing increasing. This situation indicate that the water level can reach the dangerous level anytime and can prepare their self. The last situation is danger situation where the system indicate that flood will happen and peoples who lived at the area must be evacuated immediately before the it happens.



Fig. 12 - LCD Display for (a) safe level green alert; (b) cautious level orange alert and; (c) danger level red alert

This result is taken from the testing that can be done with Ultrasonic sensor to detect the water level. The level of the water level will be indicated as safe level which is the normal level of the water, then the others are indicate as level 1, level 2 and level 3 where it will be a warning. This method can monitor the rise of the water level at the river.

Table 1 - Measurement of ultrasonic sensor [26]

Level	Distance (in cm)	Notice	Action
Safe	=> 20	-	No need for relocation
Level 1	19 > 15	WARNING - level 1-!	No need for relocation
Level 2	14 > 10	WARNING - level 2-!	No need for relocation
Level 3	9 > 0	WARNING - level 3-!	Relocation

6. Conclusion

Flood is a natural disaster that can kills peoples and also can make a major damage if it happened. Every year this issue is frequently can be heard from the television, media social etc. It will make the government losses and have to expand the budget in order to redevelop the city or area. Development of flood detection system is an alternative solution to reduce the value of people’s death and also to reduce the value of losses. This system can give a warning notification to the users to prepare and save the important things before the flood happened.

Acknowledgement

Author would gratefully acknowledge the financial support from the Universiti Malaysia Pahang and Ministry of Higher Education under grant RDU210314.

References

- [1] L. Lopez-Fuentes, C. Rossi, and H. Skinnemoen, “River segmentation for flood monitoring,” *Proc. - 2017 IEEE Int. Conf. Big Data, Big Data 2017*, vol. 2018-Janua, pp. 3746-3749, 2017, doi: 10.1109/BigData.2017.8258373.
- [2] T. Tingsanchali, “Urban flood disaster management,” in *Procedia Engineering*, Jan. 2012, vol. 32, pp. 25-37, doi: 10.1016/j.proeng.2012.01.1233.
- [3] M. S. Mai Syaheera, M. Z. Abd Karim, and B. H. Basri, “Flood disaster and GDP growth in Malaysia,” *Eur. Law Rev.*, vol. 8, no. 2, pp. 01-01, 2016, doi: 10.21859/eulawrev-08023.
- [4] Z. Mohd Taib, N. S. Jaharuddin, and Z. Mansor, “A Review of Flood Disaster and Disaster Management in Malaysia,” *Int. J. Account. Bus. Manag.*, vol. 4, no. 2, pp. 98-106, 2016, doi: 10.24924/ijabm/2016.11/v4.iss2/98.106.
- [5] M. S. Bin Khalid and S. B. Shafiai, “Flood Disaster Management in Malaysia: An Evaluation of the Effectiveness Flood Delivery System,” *Int. J. Soc. Sci. Humanit.*, vol. 5, no. 4, pp. 398-402, 2015, doi: 10.7763/ijssh.2015.v5.488.
- [6] M. E. Toriman, M. B. Gazim, M. Mokhtar, S. a. S. Mastura, O. Karim, and N. A. A. Aziz, “Integration of 1-d Hydrodynamic Model and GIS Approach in Flood Management Study in Malaysia,” *Res. J. Earth Sci.*, vol. 1, no. 1, pp. 22-27, 2009.
- [7] M. Muqtada *et al.*, “Flood Impact Assessment in Kota Bharu , Malaysia : A Statistical Analysis Faculty of Earth

- Science , Universiti Malaysia Kelantan , Jeli Campus , School of Quantitative Sciences , Universiti Utara Malaysia ,” vol. 32, no. 100, pp. 626-634, 2014, doi: 10.5829/idosi.wasj.2014.32.04.422.
- [8] N. Katuk, K. R. Ku-Mahamud, N. Norwawi, and S. Deris, “Web-based support system for flood response operation in Malaysia,” *Disaster Prev. Manag. An Int. J.*, vol. 18, no. 3, pp. 327-337, 2009, doi: 10.1108/09653560910965673.
- [9] “• Malaysia: risk index for natural disasters 2020 | Statista.” <https://www.statista.com/statistics/920888/malaysia-risk-index-for-natural-disasters/> (accessed May 22, 2021).
- [10] “Floods.” https://www.who.int/health-topics/floods#tab=tab_1 (accessed May 22, 2021).
- [11] Y. A. Shokova, G. Di, C. Yang-jian, and L. Qiang, “GSM & web-based flood monitoring system,” 2015, doi: 10.1088/1757-899X/79/1/012023.
- [12] M. S. Journal, “LabVIEW Based Flood Monitoring System,” no. April, pp. 254-260, 2020.
- [13] P. V. B. Deokamble, “FLOOD DETECTION AND ALERT SYSTEM BASED ON IOT,” no. 09, pp. 1084-1090, 2020.
- [14] S. A. Rahaman, “ISSN No : 2348-4845 Flash Flood Warning System Using Scada Systems ISSN No : 2348-4845,” vol. 2, no. August, pp. 68-75, 2015.
- [15] M. I. K. Alfahadiwy and A. Suliman, “Flood Detection using Sensor Network and Notification via SMS and Public Network,” *Student Conf. Res. Dev. (SCoReD 2011)*, no. June, pp. 1-7, 2011.
- [16] “Block Diagram 1. ArduinoMEGA2560: The Arduino Mega 2560 is a type of.. | Download Scientific Diagram.” https://www.researchgate.net/figure/Block-Diagram-1-ArduinoMEGA2560-The-Arduino-Mega-2560-is-a-type-of-microcontroller_fig5_281538436 (accessed May 23, 2021).
- [17] “Arduino Mega 2560 Board: Specifications, and Pin Configuration.” <https://www.elprocus.com/arduino-mega-2560-board/> (accessed May 19, 2021).
- [18] م. غ. س. , كوچكى ع. و. م. غ. س. , “No Title زراعى گياهان فيزيولوژى (ترجمه),” vol. 2560, pp. 68-70, 1377.
- [19] “Complete Guide for Ultrasonic Sensor HC-SR04 with Arduino | Random Nerd Tutorials.” <https://randomnerdtutorials.com/complete-guide-for-ultrasonic-sensor-hc-sr04/> (accessed May 23, 2021).
- [20] “How HC-SR04 Ultrasonic Sensor Works & How to Interface It With Arduino.” <https://lastminuteengineers.com/arduino-sr04-ultrasonic-sensor-tutorial/> (accessed May 18, 2021).
- [21] “Using I2C LCD display With Raspberry PI Pico and MicroPython - peppe8o.” <https://peppe8o.com/using-i2c-lcd-display-with-raspberry-pi-pico-and-micropython/> (accessed Dec. 21, 2021).
- [22] “In-Depth: Interfacing an I2C LCD with Arduino.” <https://lastminuteengineers.com/i2c-lcd-arduino-tutorial/> (accessed Dec. 20, 2021).
- [23] “Programming an ESP32 NodeMCU with the Arduino IDE • AranaCorp.” <https://www.aranacorp.com/en/programming-an-esp32-nodemcu-with-the-arduino-ide/> (accessed May 23, 2021).
- [24] “Arduino - Introduction.” <https://www.arduino.cc/en/guide/introduction> (accessed May 18, 2021).
- [25] “Proteus Design Suite - Wikipedia.” https://en.wikipedia.org/wiki/Proteus_Design_Suite (accessed May 18, 2021).
- [26] “Blynk IoT platform: for businesses and developers.” <https://blynk.io/> (accessed May 23, 2021).
- [27] “Blynk IoT platform: for businesses and developers.” <https://blynk.io/> (accessed May 19, 2021).