



Munich Personal RePEc Archive

**Perception of service quality in  
agrotourism accommodations: Impact on  
guest loyalty and re-visit intentions**

Chatzigeorgiou, Chryssoula and Simeli, Ioanna

Hellenic Open University, University of Macedonia

27 March 2017

Online at <https://mpra.ub.uni-muenchen.de/87914/>  
MPRA Paper No. 87914, posted 16 Jul 2018 16:32 UTC

# Perception of service quality in agrotourism accommodations: Impact on guest loyalty and re-visit intentions

**Chryssoula Chatzigeorgiou**

Hellenic Open University, Greece

**Ioanna Simeli**

University of Macedonia, Greece

Some rights reserved.

Except otherwise noted, this work is licensed under: <https://creativecommons.org/licenses/by-nc-nd/4.0>

A previous version of this paper was published in: Journal of Tourism, Heritage & Services Marketing, Volume 3, Issue 1, 2017, pp. 33-41, <http://doi.org/10.5281/zenodo.401375>

**Abstract:** *This study presents the development of a conceptual model that demonstrates the dynamic nature of the relationship between service quality and guest satisfaction in the agrotourism accommodation sector, based on theories derived from social psychology and previous research in the marketing, management, and services literature. The model was tested using sample data from guests of four different agrotourism firms, and was modified because of empirical results. The final model improves understanding of the relationship between service quality and guest satisfaction because these constructs were examined from the process perspective of an agrotourism accommodation experience; it portrays service quality and satisfaction in the context of a complete system.*

**Keywords:** Agrotourism marketing, guest satisfaction, service quality, re-visit intentions

**JEL Classification:** L83, M1, O1

**Biographical note:** Chryssoula Chatzigeorgiou holds a doctorate in agrotourism marketing from the University of the Aegean and is a distance learning tutor at the Postgraduate Program in Tourism Management of the School of Social Sciences, Hellenic Open University, Greece. Ioanna Simeli is a doctoral researcher at the Department of Applied Informatics, the University of Macedonia, Greece. Corresponding author: Chryssoula Chatzigeorgiou, e-mail: chatzigeorgiou.chryssoula@ac.eap.gr

---

## 1 INTRODUCTION

---

Agrotourism accommodations have unique characteristics that differentiate them from other industries as well as from other hospitality products. Unlike other industries, which have their own distinct products or services, agrotourism accommodations usually contain multiple products or services, and these often involve the cooperation of several suppliers. Due to the intangibility, heterogeneity, and inseparability of a significant part of the agrotourism hospitality product, it is not easy for visitors to evaluate the quality of agrotourism accommodation services. However, monitoring their perceptions of quality is of vital importance to the viability of agrotourism accommodation providers; those agrotourism firms and organisations that demonstrate a commitment to excellent service provision will almost certainly emerge as more viable entities than their competitors. The elements of service quality and satisfaction have both been central concerns in tourism and hospitality services marketing; improvement in guest satisfaction and service quality is

assumed to result in increased profits for businesses and organisations operating in service sectors. Thus, practitioners in the agrotourism industry are interested in the roles of guest satisfaction and service quality in influencing post-consumption behaviours (Prentice, Witt & Hamer, 1998). Factors as revisit intentions, word of mouth, and switching behaviour are of interest, as they enhance future agrotourism firms' revenues and assist the development of guest loyalty. Service quality and guest satisfaction are key factors in winning market share in the agrotourism industry; yet, it is not clear to agrotourism managers which of the two constructs is the means to an end, or even whether they are separate constructs (Haber & Lerner, 1998; Christou, 2003; Bazera & Gomes, 2015). For example, if they are the same construct, managers of agrotourism accommodations need to focus on improving either guest satisfaction or service quality. But, if they are two different constructs, agrotourism businesses must understand the interrelationship between them—because, given limited resources, their managers might be unable to invest in improving both constructs simultaneously. Hence, a

clear understanding of the relationship between the two constructs will enable agrotourism firms to know which of these factors is of greater significance in influencing the behavioural intentions of guests.

Both service quality and guest satisfaction are important aspects of a hospitality service. The goal of agrotourism marketers is to improve both service quality and the level of guest satisfaction. However, it has been recognised that service quality is an elusive concept for researchers and practitioners to understand (Brown, 1999). The relationship between service quality and guest satisfaction is an important issue in agrotourism marketing. Understanding the relationship between them is likely to assist agrotourism organisations in determining those aspects of an accommodation service that should be measured, which procedures should be associated with measurement of the constructs, and which are most likely to best predict the behaviours of their guests.

The central focus of this study is to examine the relationship between service quality and satisfaction of visitors and guests at agrotourism accommodations. The purpose of studying this is to understand the extent to which each of these concepts influences the intended future behaviour of guests. The work carried out here is aimed at viewing overall service quality and overall guest satisfaction as *different attitudes*. Thus, it aims to examine the process of how these attitudes are formed, the psychological processes that underlie them, and their behavioural consequences.

---

## 2 LITERATURE REVIEW

---

### 2.1 Agrotourism

Scholars and developers acknowledge that the economic development and the continuing expansion caused major (mostly negative) environmental, economic and sociocultural changes among farmers and their communities. Once modern agriculture was adopted, a massive rural outmigration took place which intensified in the 1960s and the 1970s (Anthopoulou, 2008). Soon, the negative impacts of modern agriculture and the effects on social and physical environments became a widespread concern. The realization of the environmental effects was the ideological underpinning of the concept of sustainable development (Paniagua, 2002; Günlü Küçükaltan & Pinar, 2016).

Generally conceptualizing the sustainable development, it refers to those social and ecological conditions necessary to support human life at a certain level of well-being through future generations. The core idea of sustainable development is that current economic, political and social policies should not damage prospects for maintaining or improving living standards in the future (Boo, 1990; Martins, 2016).

Given the numerous assessments of the negative consequences of the mass tourism on local systems, scientists supported the idea of a “new tourism” that lies within the natural and cultural “capacity” of the destination area. Thus, “new tourism” has been presented as a “sustainable” alternative to mass tourism. For many, sustainable tourism development holds great potential to revitalize rural areas (Tsartas, 2001; de Almeida Ramos & Fernandes, 2016).

Throughout Europe, tourism has been widely promoted as the lever to face the social and economic challenges isolated areas confront with, primarily those associated with the decline of traditional agrarian industries (Sharpley, 2002). Rural areas have been projected in the debate on tourism and sustainable development for two main reasons: first, because rurality embodies all those qualities that are missing from the urban and modern society, the urban citizen’s need to reunite with nature and rural culture (Butler et al., 1988, Logothetis, 1988). The second relates to the numerous empirical attempts in many Western countries to enjoy sustainable development as a starting point for rural policies. (Butler et al., 1998, Anthopoulou, 1998).

Gorton et al., (1998) highlighted that most tourism initiatives in rural areas initiate from urban citizens who usually invest the money they get from selling a house to a tourism business in the countryside where the investment cost is usually low. Just 6-18% of these tourism activities start from farmers who usually in crisis periods choose rather to decrease their costs from differentiating their product (Jenkins et al., 1998). However, Sharpley (2002) questioned the panacea character given to agrotourism being a “magic wand that will speed up economic progress”.

The new roles that agriculture is challenged to confront with are the protection of environment, natural life, conservation of cultural heritage and familiarity with local culture (Tsartas, 2001, Anthopoulou, 2008). Increasing interest in tourism activities developed in rural areas led within the last decade to increasing researches whereas public agencies encourage the establishment of small medium enterprises by rural population so as to keep residents in rural areas and increase employment and social welfare. (Fleischer & Felsenstein 2000). However, these small scale, highly seasonal agrotourism enterprises face many challenges among which the inability of local communities to combine the agricultural values with the guest – service values (Fleischer and Pizam, 1997) as well as the fact that the quality of products and services don’t match customers’ expectations and demands (Sharpley, 2002). Researchers have proven that tourists to rural areas look for rest and new experiences (Iakovidou 2000; Albacete-Saez et al., 2007) while simply providing accommodation facilities is not sufficient to attract visitors (Sharpley, 2002) but rather active holidays with educational and natural activities (Spilanis, 2000). Agrotourists are motivated by the formula of 3Fs (initials of the Greek words for Nature – Friendship – Hospitality) rather than 3Ss formula (Sea – Sun – Sand) (Iakovidou, 1995).

### 2.2 Service quality and satisfaction at agrotourism accommodations

A service is produced by the integration of various tangible and intangible components, and involves several employees working with a purpose to satisfy the varying wants of potential customers (guests, visitors, travellers, internal customers, and so on). An agrotourism accommodation service might be provided to a person, to an organisation, or to both. Hence, a service system can be conceptualised as a production system in which various inputs are processed, transformed, and value-added to produce outputs, which provide benefits to customers (Christou, 1999). Evaluations of service quality

embrace not only the service delivered, but also the way it is delivered. Thus, Grönroos (1984) suggested that there are two types of performance quality to evaluate—*technical quality* and *functional quality*. The former refers to the performances that the customers receive, whereas the latter refers to the process of service delivery. Similarly, Lehtinen and Lehtinen (1982) proposed three quality dimensions—*physical quality*, *corporate quality*, and *interactive quality*. Whereas *physical quality* relates to the technical aspects of the service, the latter two dimensions emphasise the corporate image of the service organisation and the interactive processes that occur between a conference organiser and its delegates.

A consideration of the numerous approaches taken to explain the nature of service quality reveals that most of the work in the field has identified two major dimensions to quality—that of the service offering (as perceived by the service provider), and that of the received service (as perceived by, for example, the delegate of a conference) (Ekinci & Riley, 2001). This approach has subsequently been refined into the ‘gap’ concept of Parasuraman, Zeithaml & Berry, (1985; Wu, 2013). Their notion identifies five discrepancies (or ‘gaps’) which can interfere with the service experience. A further refinement of the ‘gap’ concept was the development of the SERVQUAL model—an instrument that can be used as a research tool for more rigorous quality monitoring (Parasuraman, Zeithaml & Berry, 1991). Since then, several researchers have developed models that can be used for monitoring, measuring, or rating service quality (Kandampully & Butler, 1998; Tan & Pawitra, 2001; Krishnamurthy et al., 2010) or for assessing customer satisfaction (Theodorakis, Kambitsis & Laios, 2001; Wisniewski, 2001; Christou, 2011; Nella & Christou, 2016). Holbrook and Corfman (1985) and Zeithaml et al. (1996) emphasised the difference between objective and perceived quality. They said that consumers do not understand the term ‘quality’ in the same way as researchers and providers do—the latter often realising it too conceptually. The term ‘objective quality’ is normally used in the literature to illustrate the tangible technical superiority or excellence of goods or services. In contrast, the ‘perceived quality’ is the consumer’s opinion of an entity’s overall excellence or ascendancy.

Spreng, MacKenzie and Olshavsky (1996, p. 17) stated that customer satisfaction can be also defined as ‘... an overall affective state that is the emotional reaction to a product or service experience’. More specifically, this overall affective state is influenced by a consumer’s satisfaction with the product or service itself (attribute satisfaction) and with the information used in choosing a product or service (information satisfaction) (Spreng & Droge, 2001). According to Spreng MacKenzie and Olshavsky (1996, p. 17) ‘... attribute and information satisfaction are themselves produced by a customer’s assessment of the degree to which a product performance is perceived to have met or exceeded his or her desires and expectations (expectation–disconfirmation)’. However, many other researchers (for example, Cadotte, Woodruff & Jenkins, 1987; Mattila, 2001; Chen & Chen, 2010) have argued that this customer satisfaction is usually operationalised at a global level, as well as at an attribute level. The literature suggests that satisfaction can be described as either an end state or a process (Rust & Oliver, 1994; Schofield, 1999). Both views of satisfaction (as a *state* or as an *appraisal process*) involve a comparative framework by

which perceived reality is compared to expectations. They differ in that the former emphasises the outcome of the experience process, whereas the latter focuses upon the unique components of each of the stages in the experience process that combine to generate satisfaction (Lee, 1991; Vikas, Jerome & Pankaj, 2001; zabkar et al., 2010; Christou, 2015). The present study has adopted the *end state perspective* when defining satisfaction with a specific transaction (that is, quality of experience), and has adopted the *process perspective* in depicting overall satisfaction.

### 2.3 Formulation of hypotheses

The proposed model (see Figure 2) suggests that, before customers visit an agrotourism accommodation establishment, they have two kinds of expectations—*desired* and *predicted* expectations. In literature, expectations are considered to be pre-experience beliefs or evaluative beliefs about the service or product (Oliver & Winer, 1987; Zhao et al., 2012). Thus, visitors’ desired service expectations and predicted service expectations co-exist, but they are independent of each other. After visitors interact with the service, they perceive what the actual service performance is. The difference between visitors’ predicted expectations and their perceptions of actual performance constitutes disconfirmation, contributing to visitors’ levels of satisfaction (Oliver & Bearden, 1985).

Figure 1: Hypotheses tested in the study

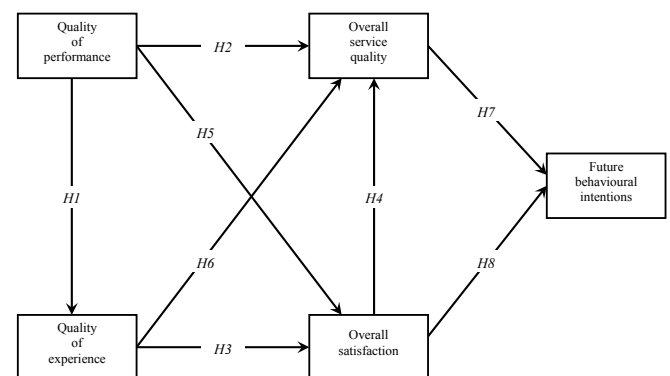

After guests interact with the accommodation service at agrotourism establishments, they perceive what the actual service performance is. If the perceived performance is different from what they had predicted, disconfirmation is likely to occur. The difference between the visitors’ predicted expectations and their perceptions of actual performance constitutes disconfirmation—which, in turn, contributes to the visitors’ levels of satisfaction. In satisfaction processes, disconfirmation is a subjective assessment that ‘... reflects the degree of perceptual distortion inherent in consumers’ own judgements of perceived reality’ (Oliver & Bearden, 1985, p. 79). It is not just a difference in numerical scores between expectations and performance; rather, it is an independent psychological state (Oliver, 1980). Guests at agrotourism accommodations compare their perceptions of actual service performance with their notion of a desired service performance, and the resulting discrepancy directs the visitors’ perceptions of quality of performance—that is, their evaluations of individual service attributes of a service. After

visitors compare their perceptions of actual performance of the service with their predicted expectations, the resulting predicted disconfirmation leads to visitors' assessments of quality of experience—which is the psychological outcome that visitors obtain during their accommodation-stay experience (Tse & Wilton, 1988; Jhandir, 2012; Liu et al., 2015). Guests' feelings of how much psychological benefit they get during the accommodation stay depend on how much disconfirmation emerges from their comparison of prior expectations with what they receive from the accommodation service. If visitors perceive quality of performance to be high, they are likely to receive more psychological benefits. Hence, *quality of performance positively influences guests' quality of agrotourism accommodation experience* (hypothesis 1).

Visitors' perceptions of performance quality on each attribute determine their overall perceptions of accommodation service quality, whereas quality of accommodation experience (which is benefit-specific satisfaction) leads to overall visitor satisfaction (Lue, 1992; Theodorakis et al., 2013). Like quality of experience and overall satisfaction, *quality of performance* and *overall service quality* are two distinct constructs. Quality of experience is the specific benefits which visitors obtain during their stay at an agrotourism accommodation, whereas overall satisfaction is the guests' level of satisfaction towards their total experience with the accommodation service (that is, it is the summation of the specific benefits). Hence, the quality of performance relates to evaluation of specific service attributes, whereas overall service quality is the evaluation of the quality of the service in general, rather than that of the attributes (Chatzigeorgiou et al., 2009; Valeri, 2016). Over time, the summation of guests' evaluative beliefs about individual service attributes will contribute to their overall evaluation of the service quality of the accommodation product. Similarly, the overall satisfaction of guests must be a summary state of all their psychological outcomes. As Bitner and Hubbert (1994) pointed out, multiple positive and/or negative experiences, which occur within the accommodation stay, will lead to a high (or low) level of overall satisfaction. Hence, *perceptions of the quality of individual agrotourism accommodation attribute performance influence perceptions of overall service quality* (hypothesis 2). In addition, it can be proposed that *perceptions of quality of agrotourism accommodation experience with individual facets influence overall satisfaction* (hypothesis 3).

It is proposed to consider overall conference service quality and overall accommodation satisfaction as two different attitudes; following the conceptualisation of the relationship between service quality and satisfaction (Zeithaml, Berry & Parasuraman, 1996; Ona et al., 2013), the proposed model predicts that, at the global level, guests' levels of satisfaction contribute to their attitudes towards overall service quality. Although they are not the same construct, overall service quality and overall delegate satisfaction can be highly correlated. Visitors' high levels of satisfaction lead to perceptions of high service quality, whereas low levels of satisfaction result in perceptions of low service quality. Support for conceptualising overall agrotourism accommodation satisfaction as an antecedent to overall accommodation service quality stems from the notion that service quality at the global level appears to have a wider scope than satisfaction (Teas, 1993; Wu, 2013). Overall service-

quality perceptions can result from any dimension, irrespective of whether they are experience-related. In contrast, guests' levels of satisfaction are purely experiential. Thus, *overall agrotourism accommodation stay satisfaction influences overall accommodation service quality* (hypothesis 4).

At transaction level, quality of performance is service quality, whereas quality of experience is guest satisfaction; transaction-specific service quality and satisfaction contribute to long-term attitudes of visitors towards the agrotourism accommodation service (Moreno et al., 2015). Therefore, quality of performance not only influences overall service quality, but also influences overall guest satisfaction. Similarly, visitors' quality of experience influences their perception of overall service quality, and contributes to overall satisfaction. When guests perceive high quality-of-service attributes, they tend to have high levels of overall satisfaction with the accommodation service; the more psychological benefits which guests obtain from the visit, the more positive the attitude that they are likely to have towards overall service quality (Nella & Christou, 2014). Hence, *quality of performance positively affects guests' levels of overall accommodation satisfaction* (hypothesis 5). In addition, it is suggested that *quality of experience positively affects guests' perceptions of overall agrotourism accommodation service quality* (hypothesis 6).

Once guests form an overall attitude towards accommodation service quality and towards overall accommodation satisfaction, it is suggested that these attitudes should affect guests' future behavioural intentions. Thus, when a visitor perceives an agrotourism accommodation to have high overall service quality, he/she is likely to say positive things about this accommodation unit, and to come back and stay in it again. Similarly, if a visitor's overall level of satisfaction with the accommodation is high, the individual is likely to disseminate positive word-of-mouth recommendation about the agrotourism unit, and is likely to visit it again. Thus, *overall agrotourism accommodation service quality is positively associated with guests' behavioural intentions* (hypothesis 7), and *overall agrotourism accommodation satisfaction is positively associated with visitors' behavioural intentions* (hypothesis 8). All hypotheses developed here are summarised in Figure 1.

---

### 3 RESEARCH METHODOLOGY

---

For the need of the survey reported here, four different agrotourism accommodations were selected, all of them at the island of Lesbos in Greece; the target population was guests at these four accommodations. A convenience sample of 400 (100 at each accommodation) was considered sufficient for valid and reliable analyses to be conducted; regarding data analysis, a sample of 200 is the minimum required for the use of structural equation modelling technique (Bollen, 1989). The sample was contacted by personal interviews and the research instrument was a questionnaire; there was surveyed every fifth guest who exited from each accommodation building. The guests were approached and asked to assist in the survey. Participants were requested to answer specific questions which

were written in a questionnaire. The responses to questions were recorded on the questionnaires by the interviewers.

The items and scales included in the questionnaire were adapted by a variety of sources. For measuring quality of performance, items were adapted by SERVQUAL (Parasuraman, Zeithaml and Berry, 1988), while the measurement of quality of experience was based on scales adapted from the Recreation Experience Preference scales which have been used in past research on leisure and tourism benefits (Manfredo, Driver & Tarrant, 1996). Since overall service quality was operationalised as an attitude towards the agrotourism accommodation, it was measured with a one-item scale which asked about the respondents' perceptions of overall quality of the service attributes at the accommodation. A 10-point scale was used to provide a wide range of variance; The scale ranged from 1 = 'extremely low quality' to 10 = 'extremely high quality'. Guests' overall satisfaction was also operationalised as an attitude towards the accommodation. However, it was postulated to be a different attitude from overall service quality. The measure for overall satisfaction was a 4-item, 7-point modified semantic differential scale (satisfied–dissatisfied, pleased–displeased, favourable–unfavourable, positive—negative). This scale was originally adapted from Crosby and Stephens (1987) who measured consumer satisfaction with the insurance industry. Later, the scale was used in the tourism field by Childress and Crompton (1997), and found to be very reliable—with a Cronbach's alpha of 0.98. Last, a 7-item, 7-point likelihood scale was used to measure guests' future behavioural intentions; Zeithaml, Berry and Parasuraman (1996) originally developed this scale. Baker and Crompton (1998) modified the scale and applied it in the context of a festival.

The data collected were first examined by descriptive statistics such as frequencies, means, and standard deviations. The purpose was to develop profiles of the total sample and to identify distributions of the variables. These descriptive analyses demonstrated: (i) the demographic characteristics of respondents, including their age, gender, education level, work status, annual household income, and country of residence; (ii) their guest characteristics, such as the number of times they had visited the specific accommodation, and their group type; and (iii) respondents' perceptions of service attributes and overall service quality of the accommodation, psychological benefits they obtained from staying at the accommodation, levels of their overall satisfaction, and their behavioural intentions.

Next, the hypotheses proposed earlier in the study were tested. A structural equation modelling (SEM) procedure was employed to test these hypotheses. SEM is an approach that can be used for the analysis of causal models with multiple indicators of latent variables of measurement errors (Bollen, 1989; Chenet, Tynan & Money, 2000). The constructs under study—such as quality of performance, quality of experience, overall guest satisfaction, and behavioural intentions—are all unobservable concepts, the measurement of which is dependent on manifest indicators.

#### 4 RESULTS, DISCUSSION AND HYPOTHESES TESTING

To test the hypotheses, the AMOS extension in the SPSS program was used. The analysis procedure followed up a two-step approach recommended by Anderson and Gerbing (1988) and Hatcher (1994). With this approach, the first step involved the conducting of confirmatory analysis to examine the fitness of the measurement model to the data, and to see if the indicator variables really were measuring the underlying constructs of interest. The second step was to test the fitness of the theoretical model (the structural model) to the data. The structural model specifies causal relationships between the latent variables themselves. The path analysis with these latent variables provided evidence of whether each hypothesis could be supported or not. The final structural model is presented in Figure 2; fit indices and Parameter estimates for the final structural model are presented in Table 1 and Table 2 respectively. The summary of outcomes of the hypotheses' testing is presented in Table 3.

Results showed that when guests perceive higher quality of individual service attributes, the benefits received from the experience are perceived as higher. At each service encounter, guests first evaluate the quality of service; the outcome of this evaluation directly contributes to the quality of a delegate's experience from staying at the agrotourism accommodation. Quality of performance is taken to be guests' evaluations of individual service attributes, and is therefore cognitive in nature. Quality of experience describes guests' psychological benefits received from interaction with the service attributes, and is affective in nature. The support for Hypothesis 1 has provided empirical support of appraisal theories, which postulate that cognition strongly influences affect.

Figure 2: Final structural model and standardised parameter estimates

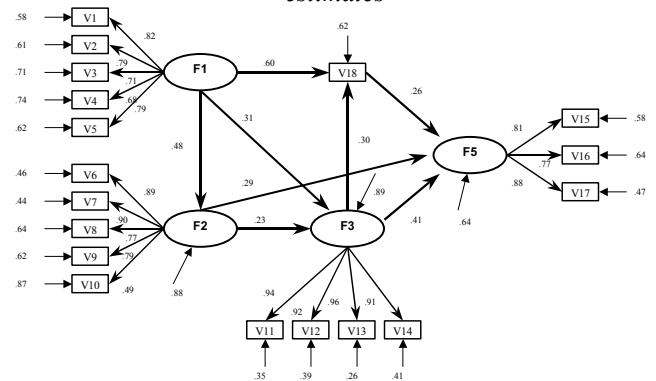

The results of the study supported both Hypotheses 2 and 3; however, the results showed that the influence of quality of performance on overall service quality was much stronger than that of quality of experience on overall satisfaction (total effects of 0.72 and 0.23, respectively). The results provided evidence to support the conceptualisation of service quality and satisfaction at different levels. The recognition of both transaction-specific and overall service quality and satisfaction helps to clarify confusion in the conceptualisation of the relationship between the two constructs. This study tested effectively the framework proposed by others (Dabholkar, Thorpe & Rentz, 1996; Baker & Crompton, 1998) that both service quality and satisfaction can be viewed at the transaction and global levels.

Table 1: Fit indices for the final structural model

Fit Index	Value
Non-Normed Fit Index (NNFI)	0.92
Comparative Fit Index (CFI)	0.94
Goodness of Fit Index (GFI)	0.86
Adjusted Goodness-of-Fit Index (AGFI)	0.81
Parsimonious NFI	0.73
RNFI	0.99
Chi-Square Test	$\chi^2 = 291.74$ $df = 124$ $p = 0.0001$

Results showed that the psychological benefits guests obtained from staying at the agrotourism accommodation did not contribute to their attitude of service quality in a major way. Benefits obtained by guests contributed to overall service quality only indirectly—through overall guest satisfaction (indirect effect of 0.07). This demonstrated that overall service quality is a cognitive-based attitude because, although evaluative quality of performance directly contributed to overall service quality (direct effect of 0.60), quality of experience did not directly influence overall service quality. Quality of experience refers to benefit outcomes, and is therefore subjective. In contrast, overall service quality is guests' relatively objective evaluations, and is therefore not easily changed by their affect. This finding of the study contradicts the position of those service-quality researchers who insist on the influence of transaction-specific satisfaction on attitude towards service quality (Parasuraman, Zeithaml & Berry, 1988; Bitner, 1990; Bolton & Drew, 1991; Hernández et al., 2016). One explanation for this contradiction lies in the different conceptualisations of satisfaction at the transaction level. The present study viewed satisfaction at the transaction level as an affective response, whereas service-quality researchers usually consider it as an evaluation of individual service attributes (Bolton & Drew, 1991), or as overall satisfaction with the service (Bitner 1990). The difference between the conceptualisations of satisfaction in this study and those in other studies (such as those conducted by the researchers described above) is that the present study distinguished satisfaction at both the transaction and global levels. In addition, the present study emphasised the affective aspects of transaction-specific satisfaction and the attitudinal characteristic of overall satisfaction; whereas service-quality researchers have viewed satisfaction as being only transaction-specific.

The hypothesised relationship between quality of performance and overall satisfaction was supported. Guests' perceptions of quality of performance directly contribute to their levels of overall satisfaction. When guests perceive high quality of service attributes, they tend to report a high level of satisfaction with their overall experience from staying at the agrotourism accommodation. The influence of quality of performance on overall satisfaction (total effects of 0.42) was stronger than that of quality of experience on overall satisfaction (total effects of 0.23). This shows that both cognition and affect are immediate determinants of overall satisfaction. However, evaluation contributed more to satisfaction attitude than affect. Thus, overall satisfaction as an attitude consists of both cognitive and affective elements, but is mainly a cognitive-based attitude.

Table 2: Parameter estimates for the final structural model

Parameter	Unstandardised Estimate	Standard Error	t value	R <sup>2</sup>
L1	0.978	0.06	17.78	0.67
L2	0.895	0.05	16.35	0.62
L3	0.936	0.07	13.61	0.50
L4	0.806	0.07	12.23	0.46
L5	1.054	0.06	16.93	0.62
L6	1.008	0.04	23.19	0.79
L7	1.155	0.05	24.95	0.81
L8	0.917	0.06	16.28	0.59
L9	1.092	0.06	18.04	0.62
L10	0.726	0.09	7.78	0.24
L11	1.012	0.04	24.25	0.88
L12	0.939	0.04	23.02	0.85
L13	0.949	0.04	26.49	0.93
L14	0.913	0.04	22.34	0.83
L15	0.918	0.05	18.07	0.66
L16	1.294	0.06	22.11	0.60
L17	1.183	0.05	23.36	0.77
B1	1.088	0.09	12.49	
B2	0.632	0.09	7.29	
B3	0.300	0.11	2.82	
B4	0.320	0.06	5.46	
B5	0.264	0.06	4.57	
B6	0.525	0.14	3.85	
B7	0.173	0.05	3.79	
B8	0.288	0.05	5.98	
F2				0.23
F3				0.21
V18				0.61
F5				0.59

In marketing literature, there has been confusion in differentiating the concepts of overall service quality and overall customer satisfaction. Several studies which tried to differentiate the two constructs at the global level failed to find supporting empirical evidence (Spreng & Olshavsky, 1993; Bitner & Hubbert, 1994; Dabholkar, 1995; Imrie, Cadogan & McNaughton, 2002; Samy, 2016). For example, Spreng and Olshavsky (1993) studied overall satisfaction and service-quality perceptions, but did not find any discriminant validity between the two constructs. However, the present study did find discriminant validity between overall service quality and overall satisfaction; results showed that the total effect of overall satisfaction on overall service quality was relatively low (0.30). This implied that, although they are correlated, overall service quality and overall satisfaction are not the same construct. A more detailed analysis showed that evaluative quality of performance had stronger influence on overall service quality (total effects of 0.72) than on overall satisfaction (total effects of 0.42). Affective quality of experience had stronger influence on overall satisfaction (total effects of 0.23) than on overall service quality (total effects of 0.07). Overall service quality and overall satisfaction should therefore be viewed as different attitudes. Although both attitudes consist of cognition and affect, overall service quality is more cognitively based, whereas overall satisfaction is more affectively based.

Results of the study supported the hypotheses relating to the influence of overall service quality and overall satisfaction on guests' future behavioural intentions. High levels of guest satisfaction, and/or perceptions of high service quality, are both likely to reinforce guests' intentions of staying at the agrotourism accommodation again in the future and their engaging in positive word-of-mouth communications with

their family and friends. These findings confirmed the predicative power of overall service quality and satisfaction on guests' future behavioural intentions—as has been reported in previous studies (Baker & Crompton, 1998, 2000). However, the influence of overall service quality on behavioural intentions was found to be much weaker than that of overall satisfaction. In fact, results showed that, of all the variables examined, overall service quality contributed the least to behavioural intentions (total effects of 0.26).

Table 3: Summary of hypotheses tested and results

No.	Hypothesis	Results
H1	Quality of performance positively influences guests' quality of agrotourism accommodation experience	Supported
H2	Perceptions of the quality of individual agrotourism accommodation attribute performance influence perceptions of overall service quality	Supported
H3	Quality of agrotourism accommodation experience with individual facets influence overall satisfaction	Supported
H4	Overall agrotourism accommodation stay satisfaction influences overall accommodation service quality	Supported
H5	Quality of performance positively affects guests' levels of overall accommodation satisfaction	Supported
H6	Quality of experience positively affects guests' perceptions of overall agrotourism accommodation service quality	Not Supported
H7	Overall agrotourism accommodation service quality is positively associated with guests' behavioural intentions	Supported
H8	Overall agrotourism accommodation satisfaction is positively associated with visitors' behavioural intentions	Supported

In a specific service encounter, guests' perception of quality of performance is a deciding factor in the experiential benefits (that is, satisfaction) received from staying at an agrotourism accommodation. Because guest satisfaction at the transaction level is affective in nature, it is a relatively short-term effect. Guests' satisfaction with a service experience eventually contributes to their long-term satisfaction with the service in general.

## 5 CONCLUSIONS

Two aspects of the present study are of great importance to agrotourism accommodation marketers. First, the study has confirmed that improved service quality and guest satisfaction can result in repeat accommodation visitation and positive word-of-mouth—which might increase the profits of agrotourism organisations. Secondly, the study clarified the relationship between service quality and satisfaction, finding that each construct has an independent effect on guests' future behavioural intentions. Agrotourism accommodation managers should recognise that guest satisfaction and service quality are *not* the same thing. The relationship between the satisfaction and service quality does *not* imply that practitioners should focus only on improving service quality—because, as this study has demonstrated, overall service quality and satisfaction can each contribute independently to guests' future behavioural intentions. In fact, the influence of overall satisfaction on behavioural intentions is stronger than that of overall service quality.

This study suggests that two factors which directly influence guests' overall satisfaction are quality of performance and quality of experience. To increase the level of satisfaction, accommodation managers need to improve the performance of the individual service attributes. This will assist guests to increase the benefits they receive from the service experience. Overall service quality and satisfaction are

*attitudes*. A change in attitude starts with changes in perceptions of quality of performance and quality of experience. Thus, the priority of accommodation managers should be on the transaction level of service quality and satisfaction.

The major contribution of the present study is that it developed a conceptual model that demonstrates the dynamic nature of the relationship between service quality and guest satisfaction at agrotourism accommodations, based on theories derived from social psychology and previous research in the marketing, recreation, hospitality and tourism literature. The model was tested using sample data from delegates of four agrotourism organisations in Greece, and was modified because of empirical findings. Follow-up studies on the issue are strongly encouraged. Refinement of the instruments used in the study, and their replication in other tourism, travel and hospitality settings, will enable both researchers and managers to understand the relationship between service quality and satisfaction more fully.

## REFERENCES

- Albacete-Saez, C., Fuentes-Fuentes, M. M., & Llorens-Montes, F. J. (2007). Service quality measurement in rural accommodation. *Annals of Tourism Research*, 34(1), 45–65.
- Anderson, J.C., & Gerbing, D.W. (1988). Structural equation modelling in practice: a review and recommended two-step approach. *Psychological Bulletin*, 103, 411–23
- Anthopoulos Th., (2008). *Women of countryside and food*. Vol 1. Athens: Gutenberg.
- Baker, D.A., & Crompton, J.L. (2000). Quality, satisfaction and behavioural intentions. *Annals of Tourism Research*, 27(3), 785–804.
- Baker, D.A., & Crompton, J.L. (1998). Exploring the relationship between quality, satisfaction and behavioural intentions in the context of a festival. *Annals of Tourism Research*, 25(2), 301–13.
- Bezerra, G.C.L. & Gomes, C.F. (2015). The effects of service quality dimensions and passenger characteristics on passenger's overall satisfaction with an airport. *Journal of Air Transport Management*, 44(4), 77–81
- Bitner, M.J. (1990). Evaluating service encounters. *Journal of Marketing*, 54(1), 69–82.
- Bitner, M.J., & Hubbert, A.R. (1994). Encounter satisfaction versus quality: the customer's voice. In R.T. Rust, & R.L. Oliver, (Eds.), *Service quality: New directions in theory and practice* (pp. 124–147). Thousand Oaks, CA: Sage Publications.
- Bollen, K.A. (1989). *Structural equations with latent variables*. New York: John Wiley and Sons.
- Bolton, R.N., & Drew, J.H. (1991). A longitudinal analysis of the impact of service changes on customer attitudes. *Journal of Marketing*, 55(1), 1–9.
- Boo, E., (1990). *Ecotourism: The Potentials and Pitfalls*, WWF, Washington, D.C.
- Brown, R.N. & Swartz, T.A. (1989). A gap analysis of professional service quality. *Journal of Marketing*, 53(1), 92–8.
- Butler, R., C. Michael Hall, and J. Jenkins, eds. (1998). *Tourism and Recreation in Rural Areas*. Chichester. Wiley.
- Chatzigeorgiou, C., Christou, E., Kassianidis, P. & Sigala, M. (2009). Examining the relationship between emotions, customer satisfaction and future behavioural intentions in



- agrotourism. *Tourismos: An International Multidisciplinary Journal of Tourism*, 4(4), 145-161.
- Chen, C.F. & Chen, F.S. (2010). Experience quality, perceived value, satisfaction and behavioral intentions for heritage tourists. *Tourism Management*, 31(1), 29-35.
- Chenet, P., Tynan, C., & Money, A. (2000). The service performance gap: testing the redeveloped causal model. *European Journal of Marketing*, 34(3/4), 472-3.
- Christou, E. (2003). Guest loyalty likelihood in relation to hotels' corporate image and reputation. *Journal of Hospitality & Leisure Marketing*, 10(3/4), 85-100.
- Christou, E. (2010). Investigating attitudes towards mobile commerce for travel products. *Tourism: An International Interdisciplinary Journal*, 58(1), 7-18.
- Christou, E. (2011). Exploring online sales promotions in the hospitality industry. *Journal of Hospitality Marketing & Management*, 30(7), 814-829.
- Christou, E. (2015). Branding social media in the travel industry. *Procedia – Social & Behavioral Sciences*, 175, 607-614. <http://dx.doi.org/10.1016/j.sbspro.2015.01.1244>.
- Christou E., Sigala M. (2001). Assessment of Service Quality and TQM Performance for Hotels: The HOSTQUAL Model. *Proceedings of the 56th International CHRIE Convention*. Toronto, Canada.
- Dabholkar, P.A. (1995). The convergence of customer satisfaction and service quality evaluations with increasing customer patronage. *Journal of Consumer Satisfaction, Dissatisfaction & Complaining Behaviour*, 8(1), 32-43.
- Dabholkar, P.A., & Thorpe, D.I. (1994). Does customer satisfaction predict shopper intentions? *Journal of Consumer Satisfaction, Dissatisfaction & Complaining Behavior*, 7(1), 61-171.
- Dabholkar, P.A., Thorpe, D.I., & Rentz, J.O. (1996). A measure of service quality for retail stores: scale development and validation. *Journal of the Academy of Marketing Science*, 24(1), 3-16.
- de Almeida Ramos, G.M. & Fernandes, J.J.L. (2016). Tourism territories in low density areas: The case of Naturtejo geopark in Portugal. *Journal of Tourism, Heritage & Services Marketing*, 2(1), 14-21. <http://doi.org/10.5281/zenodo.376330>
- Grönroos, C. (1984). A service quality model and its marketing implications. *European Journal of Marketing*, 18(1), 36-44.
- Fleischer, A. & Felsenstein, D. (2000). Support for Rural Tourism. Does it Make a Difference? *Annals of Tourism Research*, 27(4), 1007-1024.
- Fleming, J.H., Asplund, J. (2007). *Customer Satisfaction: A Flawed Measure*. Excerpted from Human Sigma: Managing the Employee-Customer Encounter, Gallup Press.
- Günlü Küçükaltan, E. & Pirnar, I. (2016). Competitiveness factors of a tourism destination and impact on residents' quality of life: The case of Cittaslow-Seferihisar. *Journal of Tourism, Heritage & Services Marketing*, 2(1), 22-29. <http://doi.org/10.5281/zenodo.376332>
- Jago, L. K., & Deery, M. (2005). Relationships and factors influencing convention decision-making. *Journal of Convention and Event Tourism*, 7(1), 23-42.
- Jenkins, J.M., Hall, M. and Troughton, M. (1998). *The restructuring of rural economies: rural tourism and recreation as a government response*. Tourism and Recreation in Rural Areas, ed. R. Butler, C.M. Hall and J.Jenkins: 43-67. Chichester, John Wiley and Sons.
- Jhandir, S.U. (2012). Customer satisfaction, perceived service quality and mediating role of perceived value. *International Journal of Marketing Studies*, 4(1), 68-78.
- Haber, S., & Lerner, M. (1998). Correlates of tourist satisfaction., *Annals of Tourism Research*, 25(4), 197-201.
- Halim, A.H.A., & Mokhtar A.R.M (2016). Creating memorable visitor experiences by assessing the satisfaction level and behavioural consequences of attendees. *Procedia Economics and Finance*, 37, 1-6.
- Hall, M., & McArthur, S. (1993). The marketing of heritage. In M. Hall, & S. McArthur (Eds.), *Heritage management in New Zealand and Australia* (pp. 212-233). Oxford: Oxford University Press.
- Hanly, P. (2012). Measuring the economic contribution of the international association conference market: An Irish case study. *Tourism Management*, 33, 1574-1582.
- Hatcher, L. (1994). A step-by-step approach to using the SAS system for factor analysis and Structural Equation Modelling. Cary, NC: SAS Institute.
- Hernández, M.R., Santana Talavera, A. & Parra López, E. (2016). Effects of co-creation in a tourism destination brand image through twitter. *Journal of Tourism, Heritage & Services Marketing*, 2(2), 3-10. <http://doi.org/10.5281/zenodo.376341>
- Iakovidou, O. (2000). Agrotourism: The small, beautiful and feminine face in tourism. In Tsartas, P., (ed). *Tourism Development Multiscientific Approaches*. Athens, Exantas (in Greek).
- Iakovidou, O. (1995). *Rural Tourism*. Conference proceedings "Rural Economy and Politics: New orientations and pursuits". Athens, 10-12 December (in Greek).
- Imrie, B., Cadogan, J., & McNaughton, R. (2002). The service quality construct on a global stage. *Managing Service Quality*, 12(1), 10-19.
- Lehtinen, J.R. & Lehtinen, O. (1982). *Service Quality: A Study of Quality Dimensions*. Helsinki: Service Management Institute.
- Liu, H.C.R., Jing, P.H.A. & Chiu, Y.Y.J. (2015). Investigating wedding quality characteristics: Evidence from Kaohsiung. *Journal of Tourism, Heritage & Services Marketing*, 1(1), 10-15. <http://doi.org/10.5281/zenodo.376325>
- Logothetis, M., (1988). *Rural Tourism – An alternative solution*. Lefteris Rigas, Athens (in Greek).
- Lue, C.C. (1992). An exploratory analysis of multi-destination pleasure travel behaviour. *Unpublished PhD dissertation*, College Station, TX: Texas A&M University.
- Mair, J., Thompson, K., (2009). The UK association conference attendance decision - making process. *Tourism Management*, 30, 400-409.
- Martins, M. (2016). Gastronomic tourism and the creative economy. *Journal of Tourism, Heritage & Services Marketing*, 2(2), 33-37. <http://doi.org/10.5281/zenodo.376346>
- Moreno, F.C., Prado-Gasco, V., Hervás, J.C., Nunez-Pomar, J. & Sanz, V.A. (2015). Spectator emotions: Effects on quality, satisfaction, value, and future intentions. *Journal of Business Research*, 68(7), 1445-1449.
- Nella, A. & Christou, E. (2014) Segmenting wine tourists on the basis of involvement with wine. *Journal of Travel & Tourism Marketing*, 31(7), 783-798.
- Nella, A. & Christou, E. (2016). Extending tourism marketing: Implications for targeting the senior tourists' segment. *Journal of Tourism, Heritage & Services Marketing*, 2(1), 36-42. <http://doi.org/10.5281/zenodo.376336>
- Oliver, R.L. (1980). Measurement and evaluation of satisfaction processes in retail settings. *Journal of Retailing*, 5(3), 25-48.
- Oliver, R.L., & Bearden, W.O. (1985). Disconfirmation processes and consumer evaluations in product usage. *Journal of Business Research*, 13(2), 235-46.
- Oliver, R.L., & Winer, R.S. (1987). A framework for the formation and structure of consumer expectations: review and propositions. *Journal of Economic Psychology*, 8(4), 469-99.

- Ona, J., Ona, R., Eboli, L. & Mazzulla, G. (2013). Perceived service quality in bus transit service: A structural equation approach. *Transport Policy*, 29(2), 219-226.
- Paniagua, A., (2002). Urban – rural migration, tourism entrepreneurs and rural restructuring in Spain. *Tourism Geographies*, 4(4), 349-371.
- Parasuraman, A., Zeithaml, V.A., & Berry, L.L. (1988). SERVQUAL: a multiple-item scale for measuring consumer perceptions of service quality. *Journal of Retailing*, 64(1), 12–37.
- Petrick, J.F., Backman, S.J., (2002). “An examination of the construct of perceived value for the prediction of golf travelers’ intentions to revisit”. *Journal of Travel Research*, 41(August): 38-45.
- Petrick, J. F., Morais, D. D., & Norman, W. C. (2001). An examination of the determination of entertainment vacationers’ intentions to revisit. *Journal of Travel Research*, 40(August), 41–48.
- Prentice, R.C., Witt, S.F., & Hamer, C. (1998). Tourism as experience: the case of heritage parks. *Annals of Tourism Research*, 25(1), 1–24.
- Samy, H. (2016). Exploring Factors that Influence Domestic Tourists' Satisfaction with Budget Hotel Services in Egypt. *Journal of Tourism, Heritage & Services Marketing*, 2(2), 17–22. <http://doi.org/10.5281/zenodo.376344>
- Seaton, A.V., & Bennett, M.M. (1996). *Marketing tourism products: Concepts, issues, cases*. London: International Thompson Business Press.
- Severt, D., Wang, Y., Chen, P. & Breiter, D. (2007). Examining the motivation, perceived performance and behavioral intentions of convention attendees: Evidence from a regional conference. *Tourism Management*, 28, 399-408.
- Sharpley R., (2002). Rural tourism and the challenge of tourism diversification: the case of Cyprus, *Tourism Management*, 23(2), 233-244.
- Sharpley R., Roberts L. (2004). Rural Tourism – 10 years on, *International Journal of Tourism Research*, 6,119-124
- Shi, Y., Prentice, C. & He, W. (2014). Linking service quality, customer satisfaction and loyalty in casinos, does membership matter? *International Journal of Hospitality Management*, 40(1), 81-91.
- Spilanis, G., (2000). Tourism and regional development. The case of Aegean islands. In Tsartas, P., (ed). *Tourism Development Multiscientific Approaches*. Exantas, Athens (in Greek).
- Spreng, R.A., & Olshavsky, R.W. (1993). A desires congruency model of consumer satisfaction. *Journal of the Academy of Marketing Science*, 21(1), 169–77.
- Teas, R.K. (1993). Consumer expectations and the measurement of perceived service quality. *Journal of Professional Services Marketing*, 8(2), 33–54.
- Theodorakis, N.D., Alexandris, K. & Karvounis, S. (2013). Predicting spectators’ behavioural intentions in professional football: The role of satisfaction and service quality. *Sport Management Review*, 16(1), 85-96.
- Tsartas, P., Kokkosis, H., (2001). Viable tourism Development and Environment. Kritiki, Athens (in Greek).
- Tse, D.K., & Wilton, P.C. (1988). Models of consumer satisfaction formation: an extension. *Journal of Marketing Research*, 25(3), 204–12.
- Valeri, M. (2016). Networking and cooperation practices in the Italian tourism business. *Journal of Tourism, Heritage & Services Marketing*, 2(1), 30–35. <http://doi.org/10.5281/zenodo.376333>
- Var, T., Cesario, F., & Mauser, G. (1985). Convention tourism modelling. *Tourism Management*, 6, 194–204.
- Wei, W., Lu, Y., Miao, L., Cai, L. & Wang, C. (2017). Customer-customer interactions (CCIs) at conferences: An identity approach. *Tourism Management*, 59, 154-170.
- Westbrook, R.A. (1987). Product/consumption-based affective responses and post-purchase processes. *Journal of Personality & Social Psychology*, 37(7), 1211–20.
- Witt, S. F., Sykes, A. M., & Dartus, M. (1995). Forecasting international conference attending. *Tourism Management*, 16(8), 559–570.
- Wu, C.W. (2013). An empirical study of the effects of service quality, perceived value, corporate image, and customer satisfaction on behavioral intentions in the Taiwan quick service restaurant industry. *Journal of Quality Assurance in Hospitality & Tourism*, 14(4), 364-390.
- Zeithaml, V.A., Berry, L.L., & Parasuraman, A. (1996). The behavioural consequences of service quality. *Journal of Marketing*, 60(1), 31–46.
- Zabkar, V., Makovec-Brencic, M. & Dmitrovic, T. (2010). Modelling perceived quality, visitor satisfaction and behavioural intentions at the destination level. *Tourism Management*, 31(4), 537-546.
- Zhao, L., Lu, Y., Zhang, L. & Chau, P.Y.K. (2012). Assessing the effects of service quality and justice on customer satisfaction and the continuance intention of mobile value-added services: An empirical test of a multidimensional model. *Decision Support Systems*, 52(3), 645-656.