

**DEPARTMENT
OF GEOGRAPHY
DISCUSSION
PAPER SERIES**

ENERGY ISSUES IN CANADA
Edited by M.L. Barker

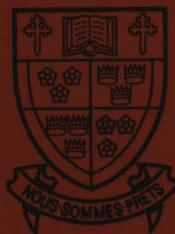

**SIMON FRASER
UNIVERSITY**

BURNABY BRITISH COLUMBIA, CANADA

\$1 per copy

ENERGY ISSUES IN CANADA

edited by M.L. Barker

February, 1978

DISCUSSION PAPER NO. 1

Disclaimer: Simon Fraser University, Department of Geography. Discussion Papers are prepared or edited by Department members for private circulation to interested individuals. Since these papers may represent preliminary work in progress, their contents should neither be quoted nor referred to in published work without written consent of the author.

Comments are invited.

ACKNOWLEDGEMENTS

I would like to thank the following people
for their contributions to the lecture series:
Dr. A.J. Hepworth, Mr. T.J. Newton, Mr. H. Maciej,
Mr. E.R. Macgregor, Dr. T.A. Ledwell and
Mr. G.M. MacNabb.

My thanks, also, to Dr. Niki Gamm of
Continuing Studies, Simon Fraser University,
who helped to organise the series.

TABLE OF CONTENTS

	PAGE
INTRODUCTION.....	1
M.L. Barker, Department of Geography Simon Fraser University	
ENERGY SUPPLY AND DEMAND IN CANADA AND BRITISH COLUMBIA.....	5
A.J. Hepworth, Director, Energy Resource Management, B.C. Energy Commission, Vancouver.	
ENERGY CONSERVATION.....	27
T.J. Newton, Manager, Energy Services Division, B.C. Hydro and Power Authority, Vancouver.	
THE FUTURE OF OIL AND GAS IN CANADA.....	51
H. Maciej, Technical Director, Canadian Petroleum Association, Calgary.	
COAL AS A MAJOR ENERGY RESOURCE.....	72
E.R. Macgregor, Assistant Deputy Minister, Ministry of Mines and Petroleum Resources, Victoria.	
CANADA'S ENERGY STRATEGY.....	108
G.M. MacNabb, Deputy Minister, Department of Energy, Mines and Resources, Ottawa.	

INTRODUCTION

M.L. Barker
Department of Geography
Simon Fraser University

During the Fall Semester, 1977 the Department of Geography and Continuing Studies, Simon Fraser University presented a public lecture series, 'Energy Issues in Canada.' The series was intended as a forum for public debate, with six lectures presented by experts playing significant roles in today's energy decisions. The lectures addressed a range of topics, including energy supply and demand forecasts, the problems and potential of fossil fuels, the opportunities offered by renewable energy sources, and energy conservation. The final lecture in the series focussed upon current federal energy policy.

In response to the interest shown in the series, we decided to issue a volume of proceedings in order that the information and viewpoints presented in the lectures could reach a wider audience. The following papers are arranged in order of presentation. Unfortunately it has not been possible to include the discussion of renewable energy sources and technologies given in the fifth lecture of the series.¹

Most authors address the Canadian and provincial energy scene in the context of world trends: the price increases introduced by OPEC (Organisation of Petroleum Exporting Countries) in 1973, and the looming gap between world demand and supply of petroleum which will result in a deficit sometime during the 1980s. These trends have undermined our sense of energy security, forced a reexamination of present energy use patterns, and given support to the idea of energy conservation.

¹ 'Alternative Energy Sources and Technologies', a lecture presented by T.A. Ledwell, Technical Advisor, Renewable Energy Resources, Department of Energy, Mines and Resources, Ottawa.

Having agreed upon the origins of our present dilemma, the authors offer a variety of alternative views of our energy future, including massive investments to develop the Alberta tar sands, substantial new coal developments in western Canada, more intensive use of renewable sources such as solar energy, and the need for a major effort in energy conservation.

In his discussion of energy supply and demand forecasts, Hepworth reviews British Columbia prospects within a broader Canadian context. Assuming world deficits in crude oil production between 1983 and 1987, and recognising the need to reduce Canada's reliance on imported petroleum, Hepworth foresees natural gas playing a key role in B.C.'s future energy mix. The future contributions of oil and natural gas, electricity, wood wastes, coal and renewable energy are reviewed in his paper. Hepworth also discusses the probable impact on energy demand in B.C., and the role of the province and federal government in energy policy-making and management.

In his paper, Newton defines the purpose of energy conservation: to prolong the life of finite energy resources and to make optimum use of renewable energy supplies to meet social goals. Actions suggested range from improving the efficiency of energy consumption without altering the purpose of energy use (e.g. more efficient cars), retro-fitting existing buildings (e.g. installing better insulation) and improving maintenance, to substantial changes in our lifestyle. Newton briefly reviews the potential for energy savings in the residential, farm, commercial, transportation and industrial sectors. In each case, he states that conservation can be achieved by a variety of approaches involving different degrees of infringement on personal freedom, from education to regulation and rationing. He summarises some of the energy conservation programmes adopted at the federal and provincial

level, and discusses the nature of energy savings that could be achieved by a B.C. Hydro designed home.

In discussing the future of oil and natural gas, Maciej emphasizes the position of Canada in the global energy context. This leads him to elaborate upon the opportunities which set Canada apart from most oil-consuming nations: our potential to become self-sufficient in petroleum, thus removing us from competitive bidding for scarce world resources.

Given a domestic shortfall predicted to occur between 1981 and 1983, the negative impacts of growing oil imports on the balance of payments, and the rising costs of the Oil Import Compensation Programme, Maciej foresees a continued all-out effort to find remaining conventional supplies and a great opportunity provided by the development of Alberta's tar sands. He points out the economic and technological frontiers to be overcome in such a development. Given the nature of the challenge and the long lead times required, Maciej predicts changes in the Canadian petroleum industry and raises questions concerning the role of government in such developments.

Macgregor states that trends in energy demand and the predicted shortfall in petroleum supply have led to a renewed interest in coal, the largest fossil fuel resource in the world. He stresses the considerable potential of coal resources, albeit recognising a number of significant constraints. These include transportation logistics and costs, manpower recruitment and training, large capital requirements, negative environmental impacts, mining technology, technology of coal utilization, and government policies. Macgregor focusses in particular, on emerging technologies for coal gasification and on recently adopted government policies, including the B.C. Coal Policy and the Coal Development Assessment Procedure.

In the final paper of the series, MacNabb discusses federal energy policy. Global and national trends in oil supply and demand are assessed, with particular attention drawn to the growing gap which must be bridged in the short-term (to 1990) by insecure oil imports, interfuel substitution and conservation. Renewable technologies may meet 3 per cent of the total demand by 1990. (This may seem a small contribution but it is equivalent, for example, to 50 per cent of the projected heating requirements).

Given that there are no simple solutions - new technologies will contribute but not meet our pre-1990 energy requirements - MacNabb argues that we need more aggressive action concerning energy conservation and development of the available resource base. Given the lengthy lead times, decisions must be made soon.

MacNabb reviews recent actions taken by the federal government (e.g. negotiations for new heavy oil developments, the recent northern gas pipeline approval, increased research into alternative energy sources, steps taken to encourage and enforce energy conservation) and concludes with a discussion of oil pricings and federal government revenues.

The amount of information contained within this volume is considerable, the viewpoints varied. We hope that these papers, by defining the present situation, emerging problems and alternative solutions, will help the reader to evaluate priorities and make the choices in the ensuing debate.

ENERGY SUPPLY AND DEMAND IN CANADA AND BRITISH COLUMBIA

A.J. Hepworth, Director,
Energy Resources Management,
B.C. Energy Commission

Before I comment briefly on the probable long range requirements for energy in British Columbia, I intend to spend much more time talking about the energy world we now inhabit. Regrettably, British Columbia is not an energy self-sufficient island and we must shape our policies accordingly.

It is widely known that the world price of oil took a dramatic jump at the end of 1973 as a result of the actions of the OPEC cartel. In fact, we experienced an approximately threefold increase in oil prices literally almost overnight. But the actions of the cartel have had another impact. They have caused us to devote far more attention to assessing just what we have available in the energy warehouse and to how we should be pricing our stores. What amounts of natural gas, coal, electricity, and of course, oil, can we really rely upon? What are the emerging trends as we search for new supplies? And how should the changing scene be reflected in fuel prices in the marketplace?

In Canada, as elsewhere, our analysis of supply potential has provided a rude awakening. In the five-year period, 1971 to 1975, we produced three times as much oil as we found: 2.75 billion barrels and .82 billion barrels, respectively (see Table 1). We have entered a stage of inventory drawdown. For natural gas the picture has been only slightly brighter: 15.0 trillion cubic feet of additions to proven reserves compared to 15.1 trillion cubic feet consumed over the same period (see Table 2). Fortunately, the past two years have seen a marked upswing in finding rates for natural gas, and so we have been able to add a little to our known reserves. Nevertheless, all in

TABLE 1
 CRUDE OIL, CANADA
 GROSS ADDITIONS TO RESERVES VS PRODUCTION
 1971-1975
 (million barrels)

	Gross Additions to Proved Reserves	Production
1971	254.2	476.3
1972	205.1	541.9
1973	279.7	636.0
1974	98.2	596.8
1975	<u>- 15.4*</u>	<u>504.1</u>
Five Year Totals	821.8	2,755.1

* Due to downward revisions in reserve estimates.

Source: Canadian Petroleum Association Statistical Yearbook
 1971-1975.

TABLE 2
 NATURAL GAS, CANADA
 GROSS RESERVE ADDITIONS VS PRODUCTION
 1971-1975
 (Bcf)

	Gross Additions to Proved Reserves	Production
1971	4,039.3	2,598.2
1972	- 272.7*	3,005.1
1973	1,776.9	3,216.6
1974	6,633.7	3,129.5
1975	<u>2,597.9</u>	<u>3,155.1</u>
Five Year Totals	15,047.7	15,104.4

* Due to downward revisions in reserve estimates.

Source: Canadian Petroleum Association Statistical Yearbook,
 1971-1975.

all, it is a gloomy picture.

Figures 1 and 2 show oil and gas supply/demand balances prepared by the federal Department of Energy, Mines and Resources in 1976. According to Figure 1, Canada will have to import more than a million barrels of oil per day by the late 1980's. At today's oil price of \$14/barrel this represents an expected foreign exchange liability of approximately \$5 billion/year. This prospect is particularly daunting when it is realized that Canadian exports of natural gas, currently worth about \$2 billion per year, are scheduled to terminate at about the same time.

It is becoming increasingly doubtful whether it is realistic to assume even the kinds of growth in oil demand shown in these 1976 forecasts. Enormous pressures will be brought to bear to minimize our foreign trade deficit on the energy account, and to attempt to ensure that we do not reach the outcome shown.

Figure 3 shows a more recent forecast of oil supply and demand in Canada released by the National Energy Board in February, 1977. This projection shows greatly reduced growth rates in demand for oil but also less optimism about future domestic supply. The shortfall has grown! (see also Table 3) The most recent National Energy Board forecast of supply and demand for natural gas was released in June, 1977. This report shows demand outstripping southern-basin supply by 1990, with a rapidly deteriorating situation thereafter.

What about our ability to purchase offshore oil to balance our expected deficiencies? Figure 4 shows a CIA forecast of OPEC's expected ability to supply future free world oil needs. A deficit in supply is shown for 1983.

FIGURE 1

CRUDE OIL DEMAND VS POSSIBLE PRODUCTION LEVELS IN PRESENT PRODUCING REGIONS

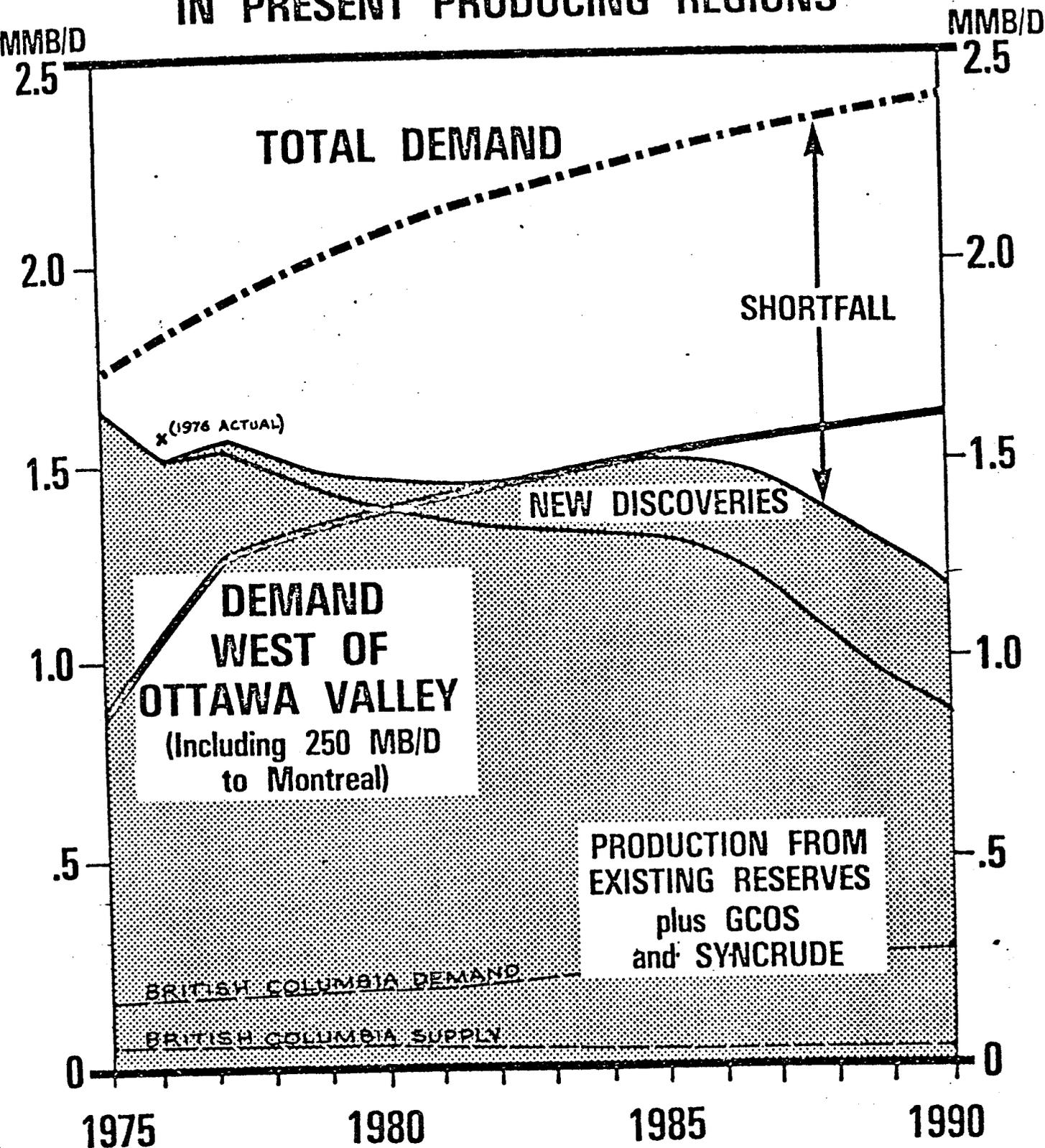

FIGURE 2

NATURAL GAS DEMAND VS POSSIBLE PRODUCTION LEVELS IN PRESENT PRODUCING REGIONS

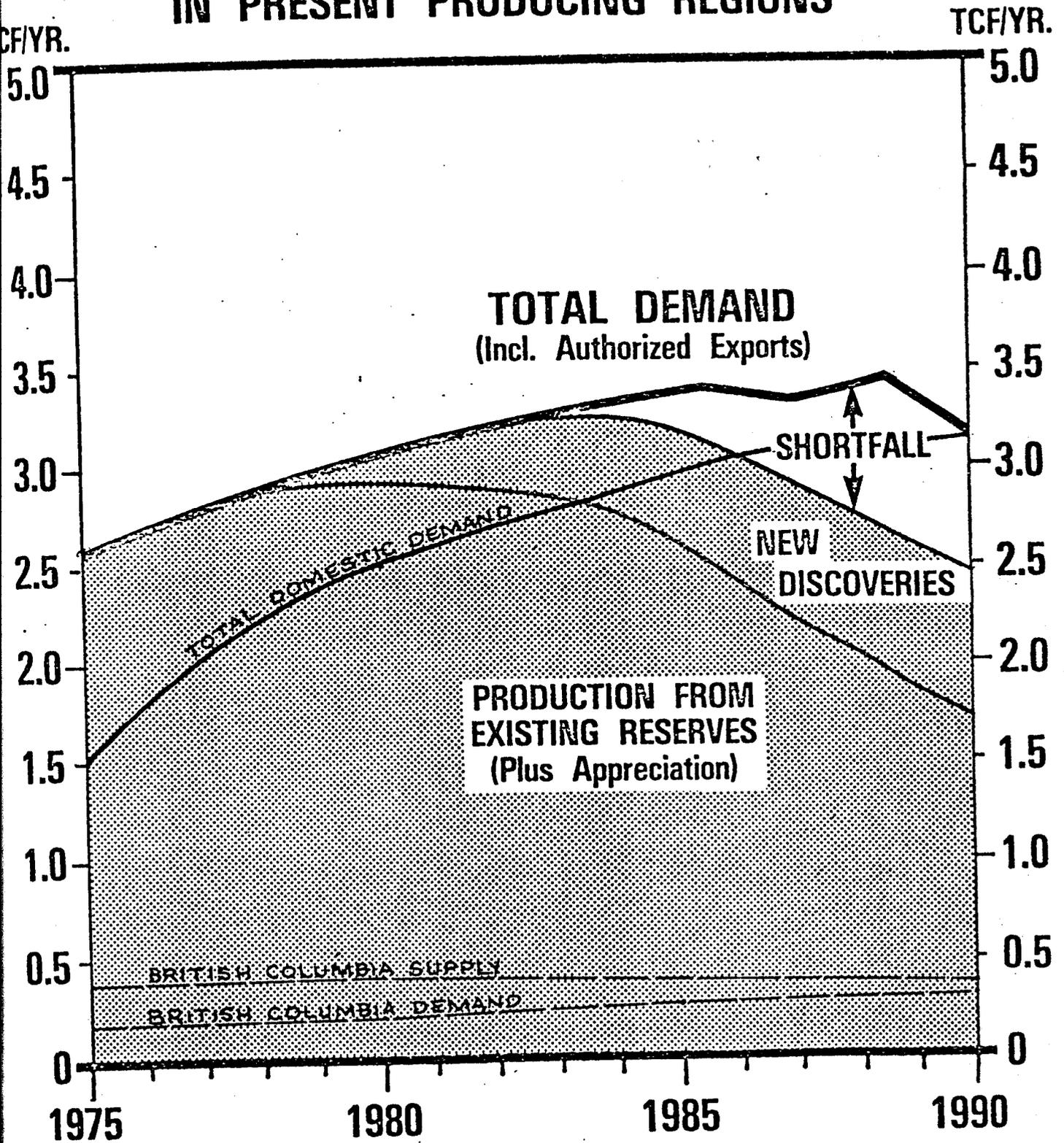

FIGURE 3

CANADA'S OIL SUPPLY/DEMAND BALANCE

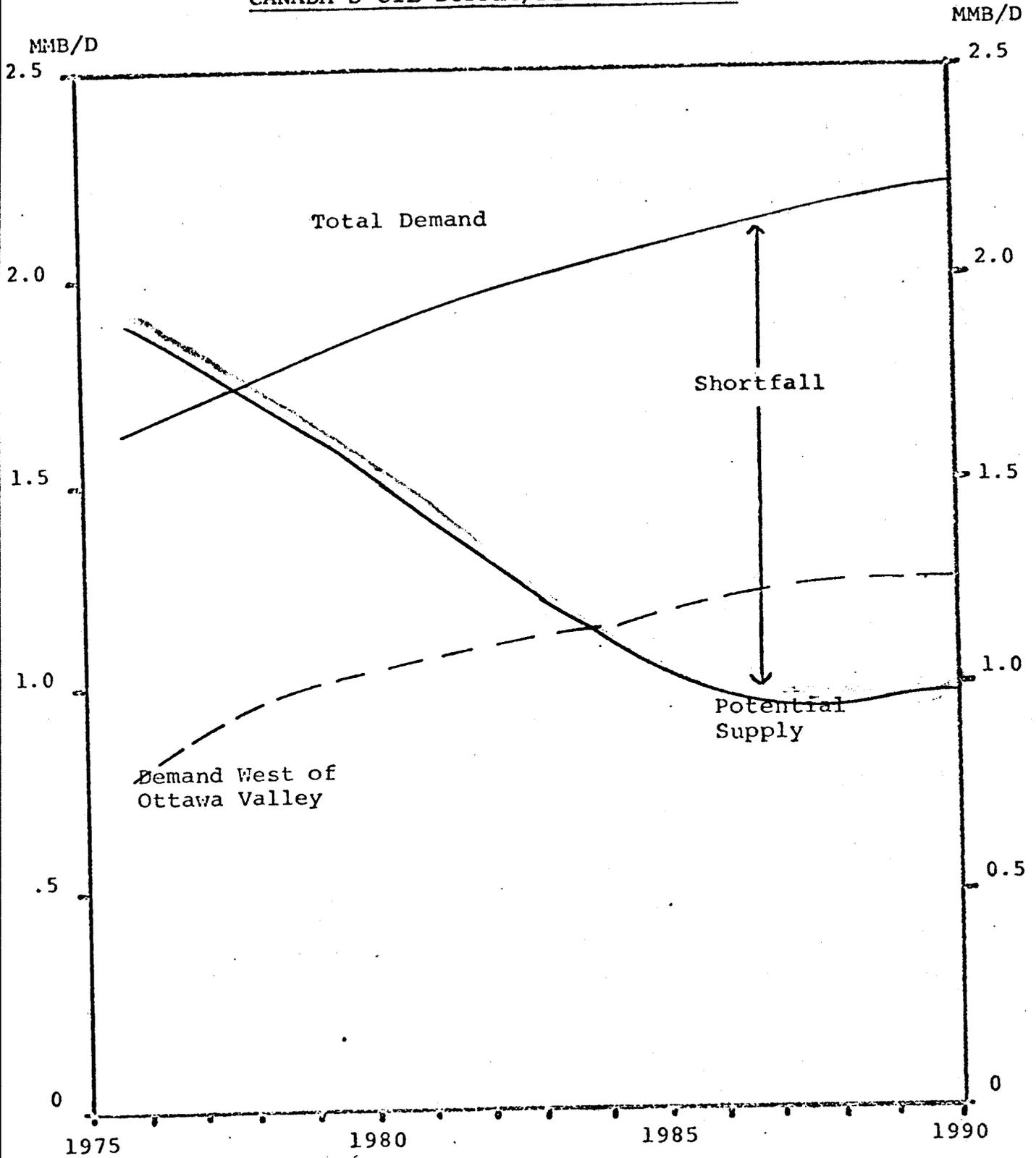

TABLE 3
 CRUDE OIL SUPPLY AND REQUIREMENTS
 CANADA
 (thousand b/d)

	Canada	W of Ottawa Valley	E of Ottawa Valley	Potential Supply	Deficit
1977	1,760	950	810	1,837	(77)
1978	1,826	992	834	1,726	100
1979	1,872	1,021	851	1,640	232
1980	1,922	1,056	866	1,533	389
1985	2,099	1,146	953	1,057	1,042
1990	2,231	1,244	987	959	1,272
1995	2,431	1,358	1,037	1,032	1,399

Source: National Energy Board, Canadian Oil
 Supply and Requirements.

Another forecast prepared by the federal Department of Energy, Mines and Resources shows the deficit in supply occurring by 1987 (see Figure 5). Even if these reports prove too pessimistic, we have good cause for concern.

In its 1976 energy policy document An Energy Strategy for Canada, the Federal Government sets out a strategy to deal with this impending difficult energy supply situation. A major target is the limitation of our net dependence on imported oil in 1985 to one third of our total oil demands. Other targets are the raising of oil prices to world levels; reducing the average rate of growth of energy in Canada to 3.5 percent per year; maintaining self reliance in gas supply until frontier supplies become available; and doubling exploration and development activity in Canada by 1979. One important policy element set out in the federal report as a required step for the achievement of these goals is interfuel substitution: in short, the substitution of more abundant for less abundant forms of energy.

In Canada, management of energy resources is the responsibility of the Provinces in the first place. Only when energy resources move across provincial or international boundaries does the Federal Government assume jurisdiction. For this reason both the Federal and Provincial Governments have energy planning offices.

In British Columbia the Energy Commission fulfills the energy policy formulation and management role. Advice is provided to the Government covering a wide spectrum of energy matters. Of course a major and on-going element of the Commission's work is to prepare British Columbia forecasts of energy supply and demand to provide a sound basis for long-term provincial energy planning.

FIGURE 4

OPEC OIL: THE SUPPLY/DEMAND GAP

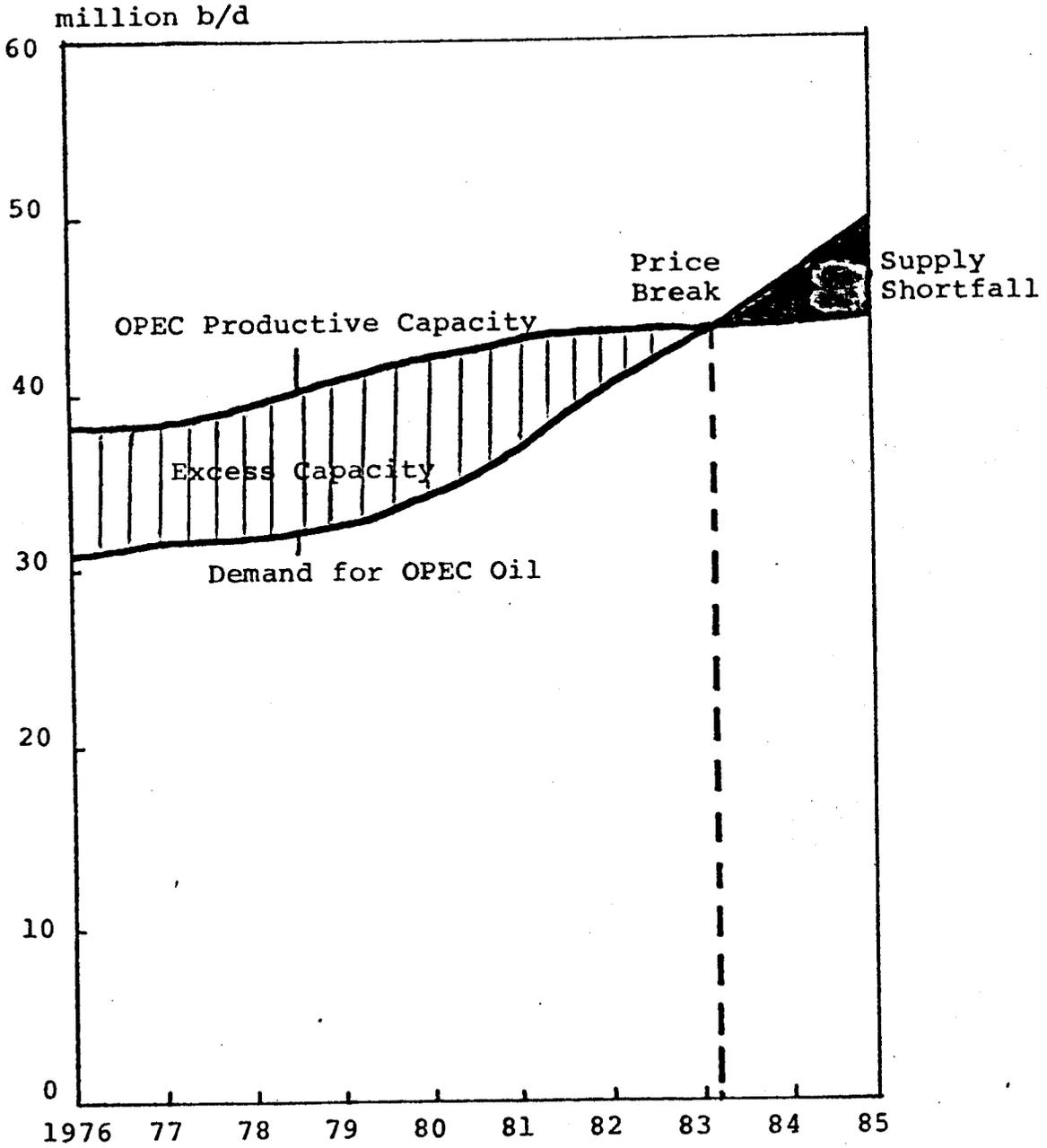

Source: CIA, The International Energy Situation to 1985.

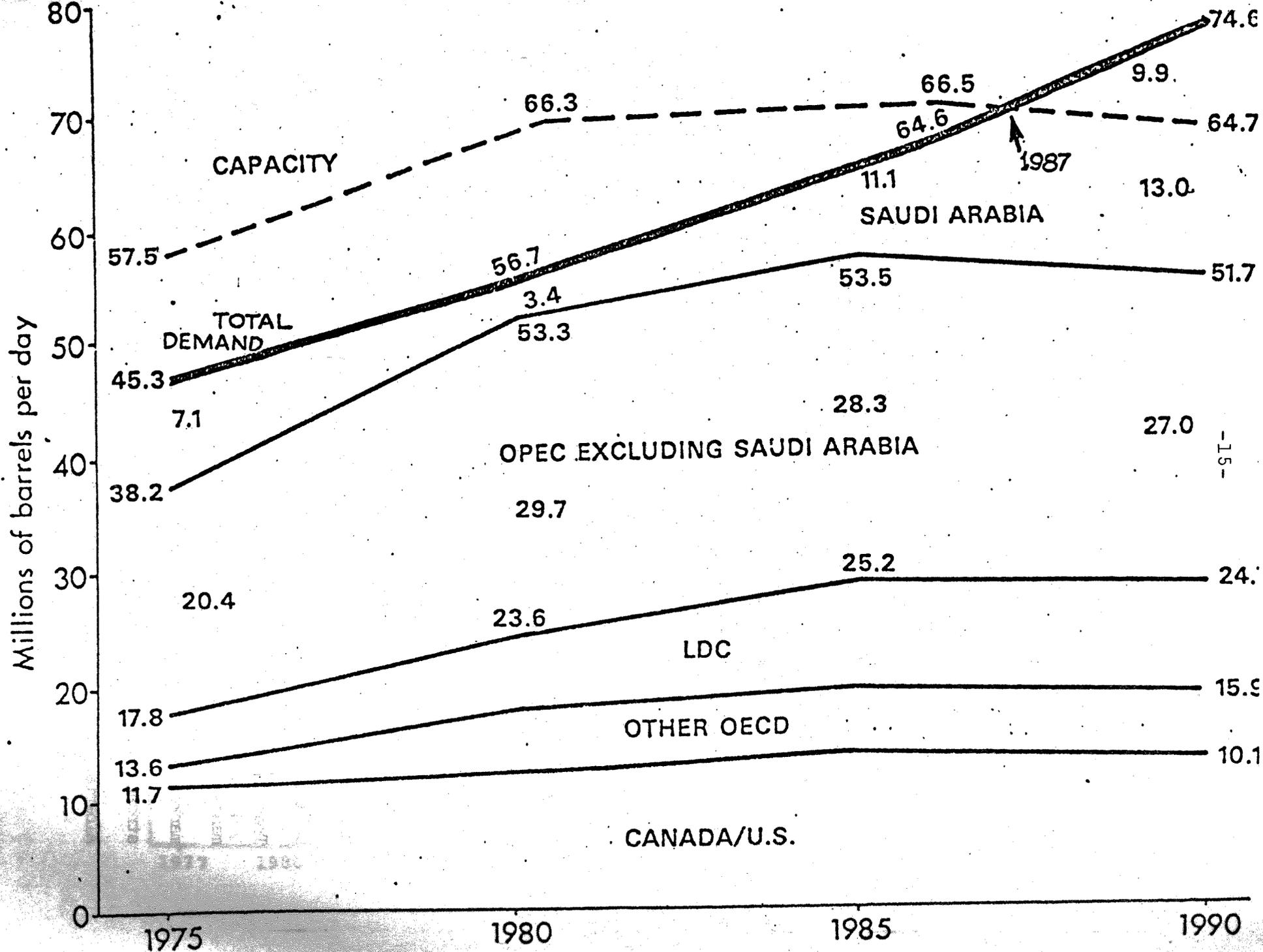

In British Columbia our two principal fuels are oil and natural gas, which represent 51 percent and 20 percent, respectively, of the total supply. Electricity supplies about 19 percent of provincial energy requirements.

a) Natural Gas

Natural gas is a key fuel in British Columbia. We are gas rich in that we produce almost twice as much as we consume, with the balance being sold into the export market (principally for use in Seattle, Spokane, and Portland). Over the long run there is a good opportunity to reduce our dependency on oil by substitution of natural gas.

Figure 6 shows a recently prepared supply/demand forecast for natural gas in British Columbia. It is a rather complicated diagram as it attempts to show the effect of the termination of the export contract in 1989. The important conclusion illustrated by the graph is that supplies are expected to be adequate to meet growing provincial requirements for many years to come. Over the very long haul it is possible that coal gasification may provide a supplement to conventional supplies of gas.

b) Crude Oil

Figure 7 shows British Columbia's oil supply/demand balance. Unfortunately B.C. domestic production is now rapidly declining, with the balance of our supplies provided by Alberta through the facilities of the Trans Mountain Pipeline Corporation. As Alberta production falls below demands in its traditional markets (i.e. west of the Ottawa Valley) those markets will have to find new sources of supply. Our province has taken a strong position that B.C. requirements should continue to be supplied from Alberta. The deficiency in supply would then be accommodated by supplies from

FIGURE 6

PROVINCIAL NATURAL GAS SUPPLY/DEMAND BALANCE
(Low Requirements Forecast)

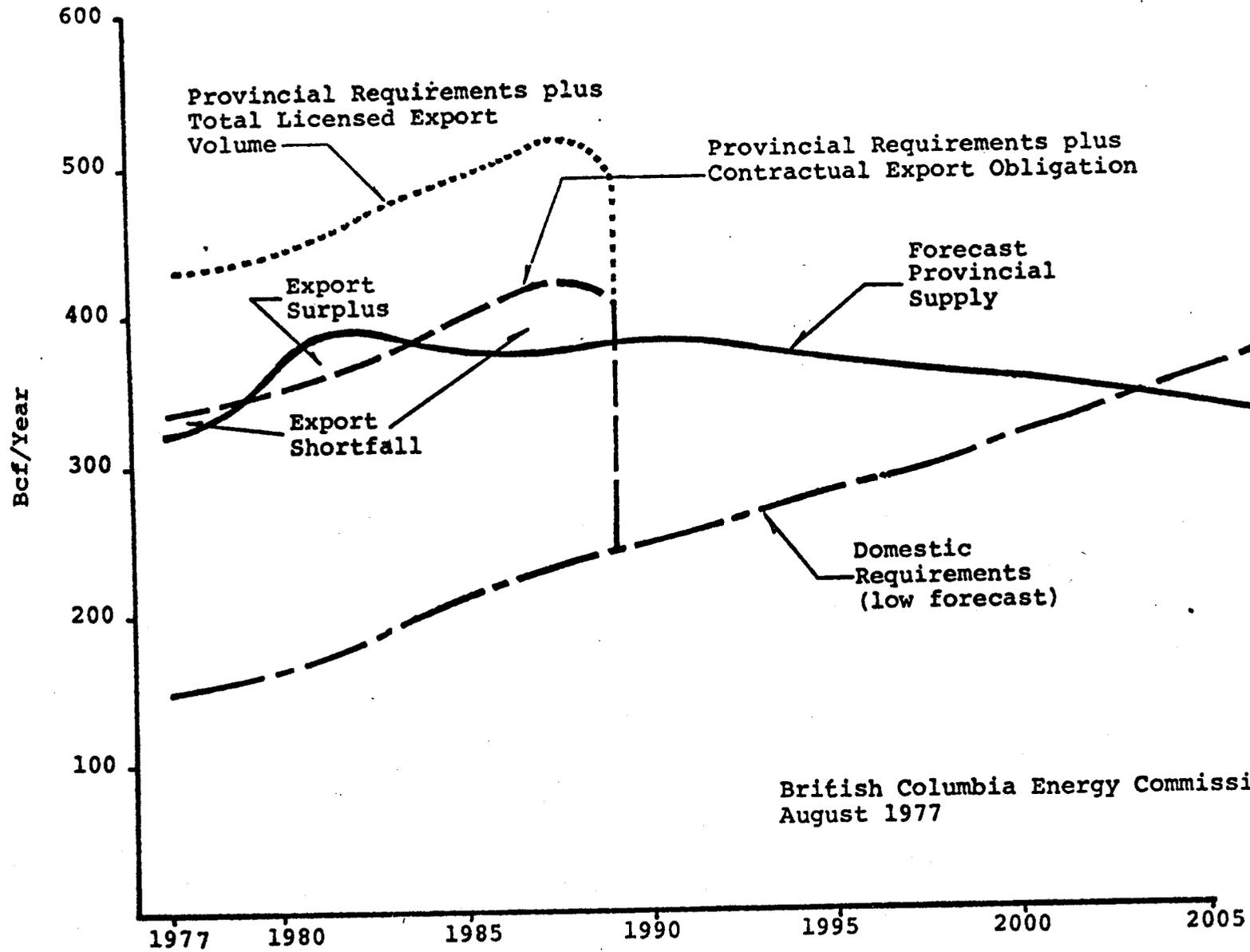

British Columbia Energy Commission
August 1977

Figure 7

B.C. CRUDE OIL SUPPLY AND DEMAND 1976-1991

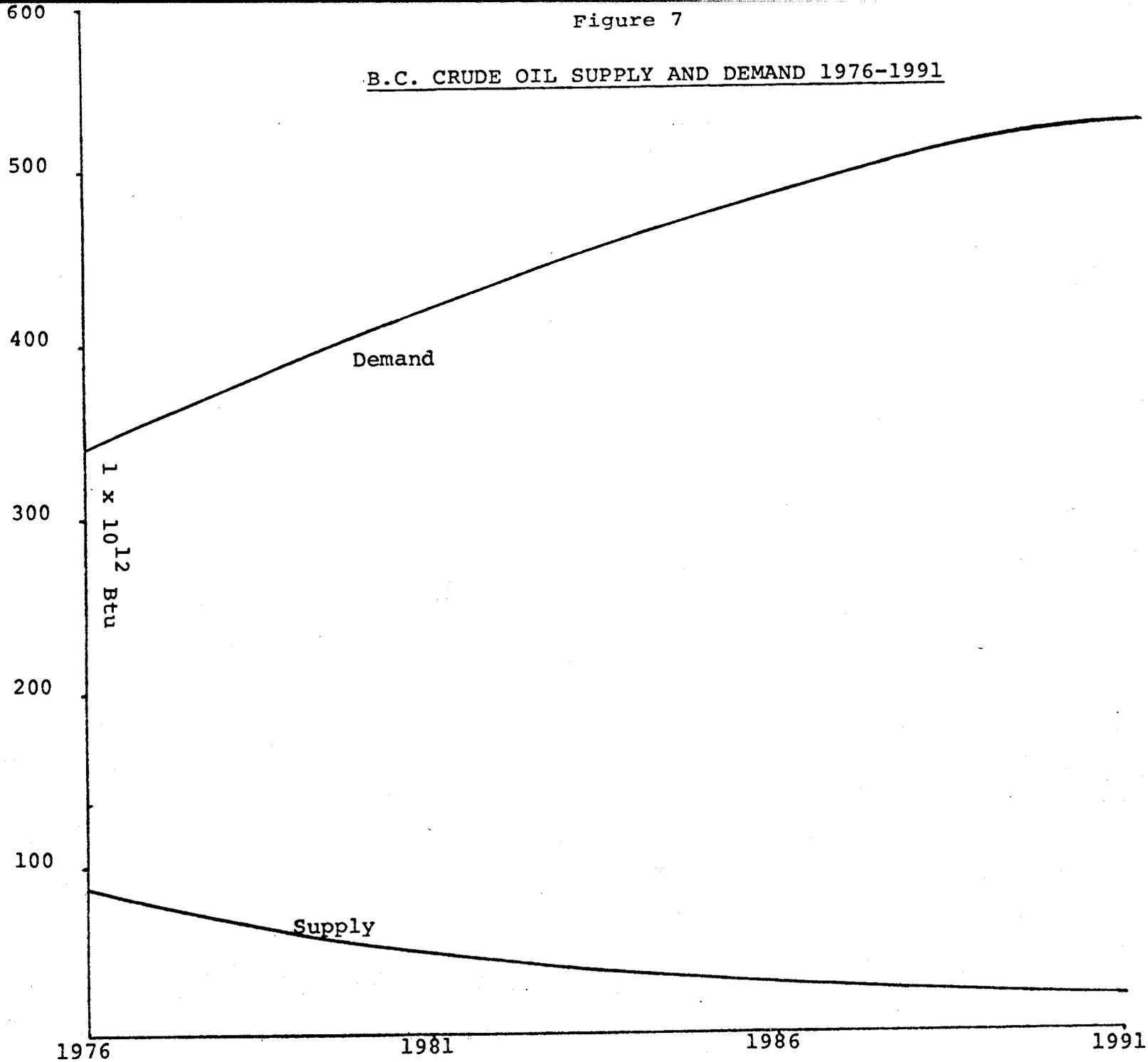

offshore moving into Ontario markets west of the Valley.

c) Electricity

I have not shown a graph of electricity supply and demand as there is little doubt that generation facilities, either hydro or coal, can be provided to meet growing requirements. Current forecasts by both B.C. Hydro and ourselves place expected growth at between 6 and 7 percent per year in Hydro's system.

d) Wood Waste and Coal

I would be remiss if I did not comment briefly on two fuels which are once again becoming important energy sources, namely wood waste and coal. It is difficult to estimate precisely what growth these fuels can expect, but there is no doubt that they will find increasing application as the prices for alternative fuels rise.

Already we are seeing a widespread use of waste wood by the forest industry, and this trend will grow. The Energy Commission is presently undertaking studies jointly with the Council of Forest Industries and the Federal government to develop more efficient applications of wood waste. Similarly, B.C. Hydro and the Federal government are studying more efficient ways to use our very large provincial coal resources.

e) Renewable Energy

As in the case of wood waste and coal, it is not yet possible to prepare realistic forecasts showing the impact of renewable energy in British Columbia. During this coming year we will be conducting an assessment of the potential contribution to supply by wind, solar and tidal energy. Preliminary work shows that solar is the most promising, but

it will be several decades before we can expect any of these sources to make a substantial contribution.

f) Energy Conservation

Finally, I would like very briefly to illustrate the probable impact of energy conservation on energy demand in British Columbia.

Figure 8 shows the impact on residential energy requirements from introducing a new building code and from upgrading insulation in old housing stocks.

Figure 9 shows the impact on energy consumption by the commercial sector of the proposed energy-efficient building standards for commercial buildings.

Figures 10 and 11 shows the effect of new Federal government mileage standards for new automobiles.

The demand curves can obviously be bent down by conservation, and in the following paper some of the ways that this can be done are discussed.

What is important about carefully prepared forecasts of energy requirements is not that they show us with great precision where we will be in, say, two to fifteen years. Rather they show us the dangers of our present course. They allow us to test the outcomes of different energy management strategies designed to limit growth. They allow us to examine the extent to which we can hope to redirect consumption towards more abundant energy forms. They provide the essential base for sound long range energy planning.

FIGURE 8

RESIDENTIAL DEMAND FORECASTS

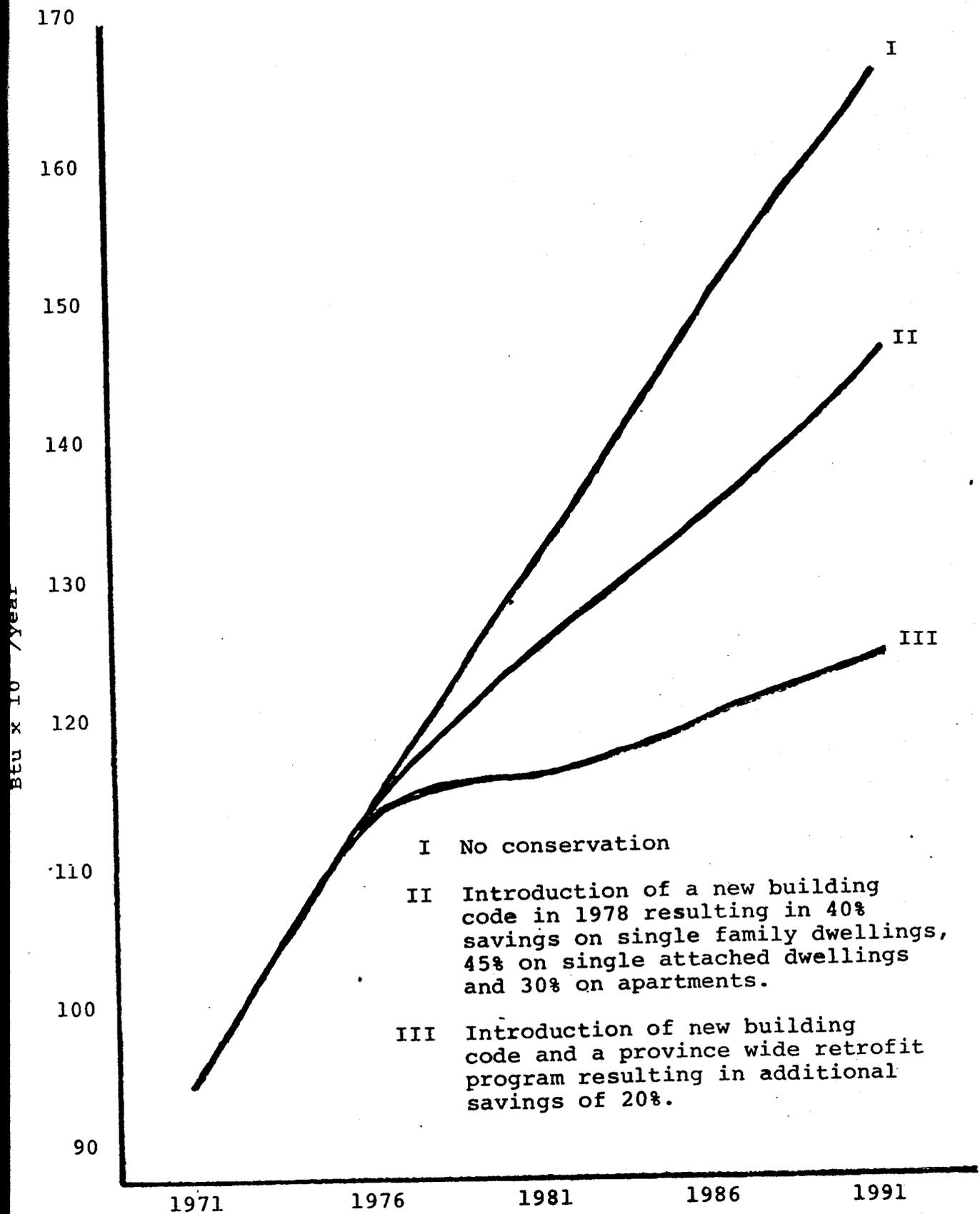

FIGURE 9

COMMERCIAL DEMAND FORECAST

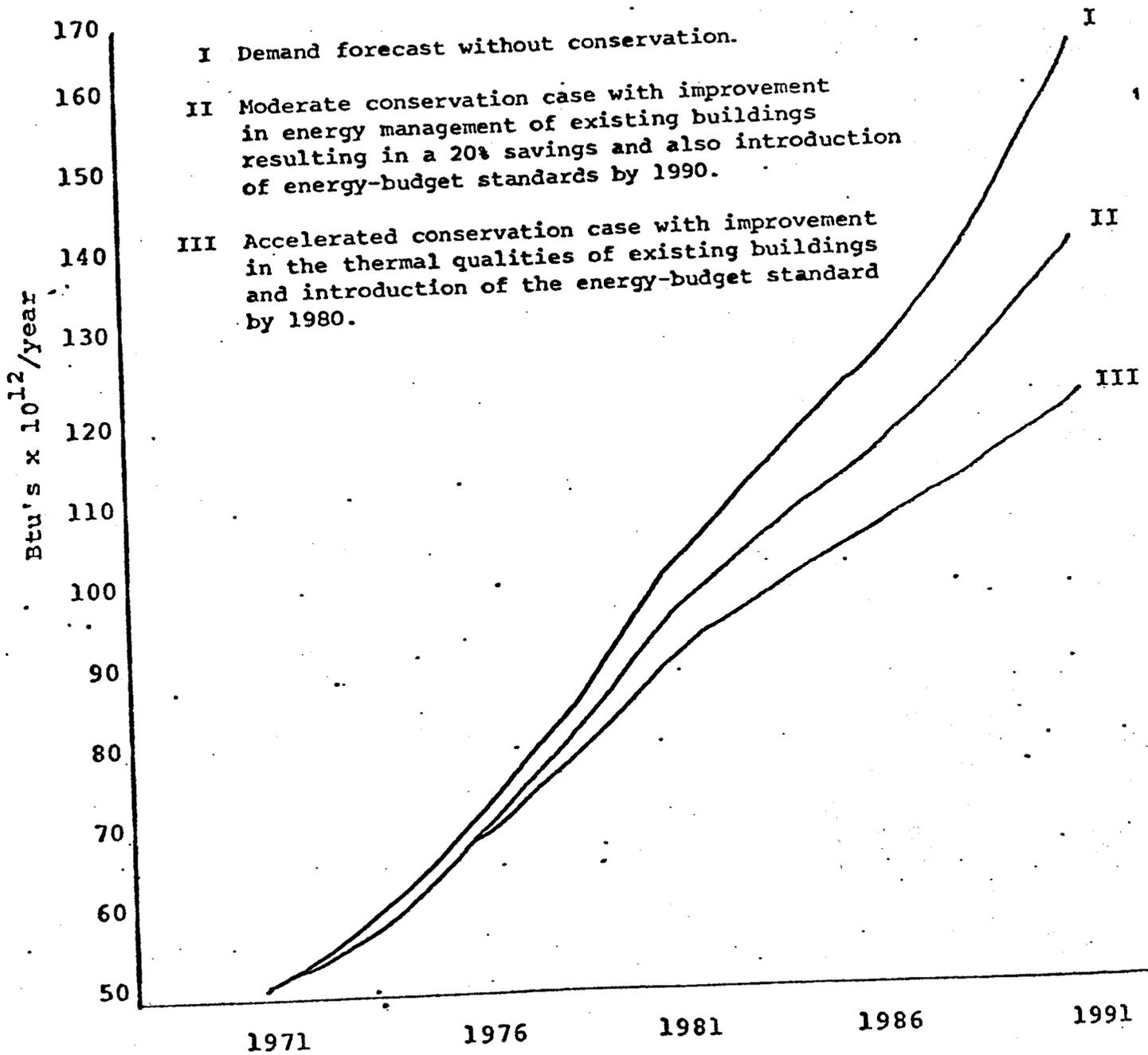

FIGURE 11

TRANSPORTATION DEMAND FORECASTS

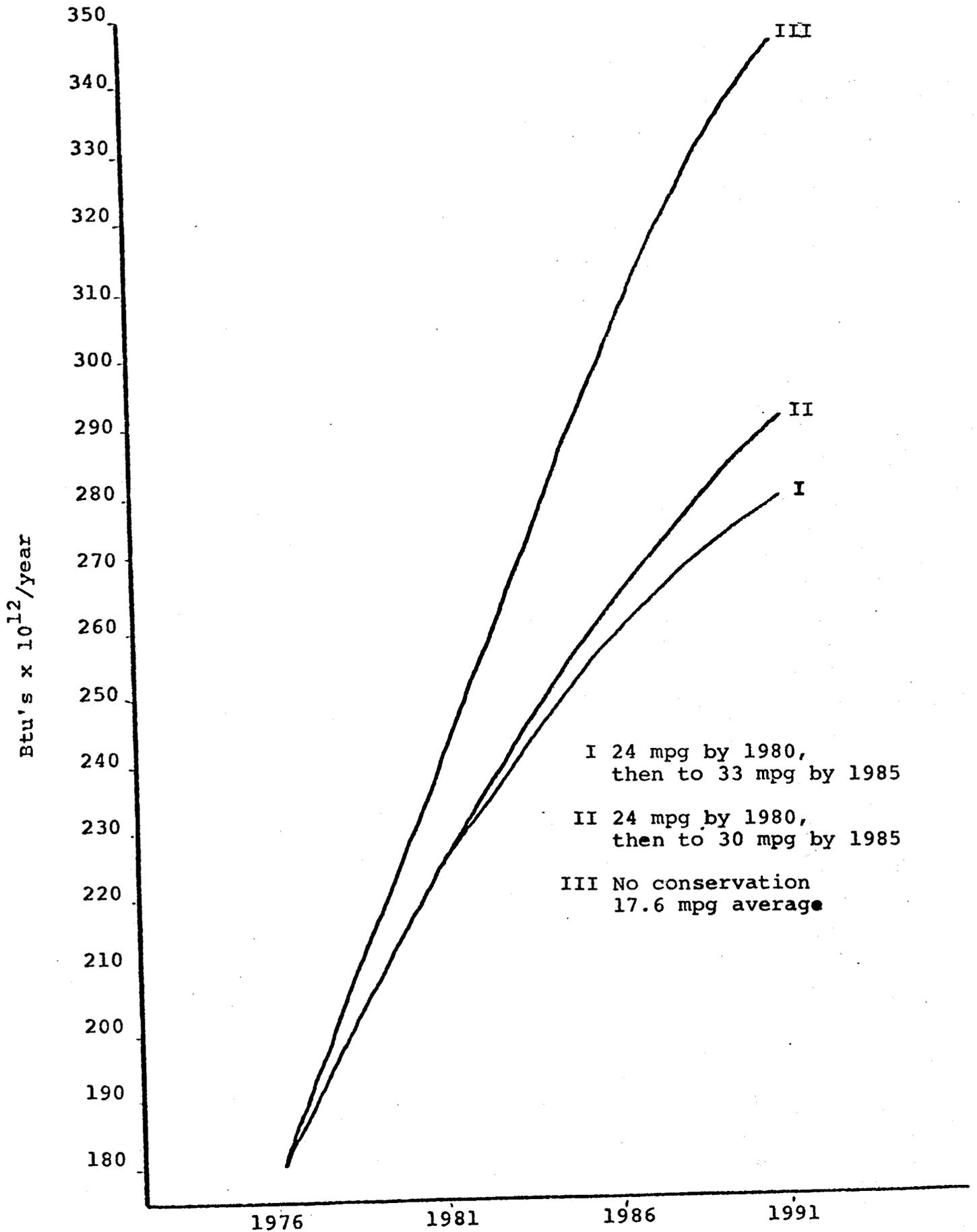
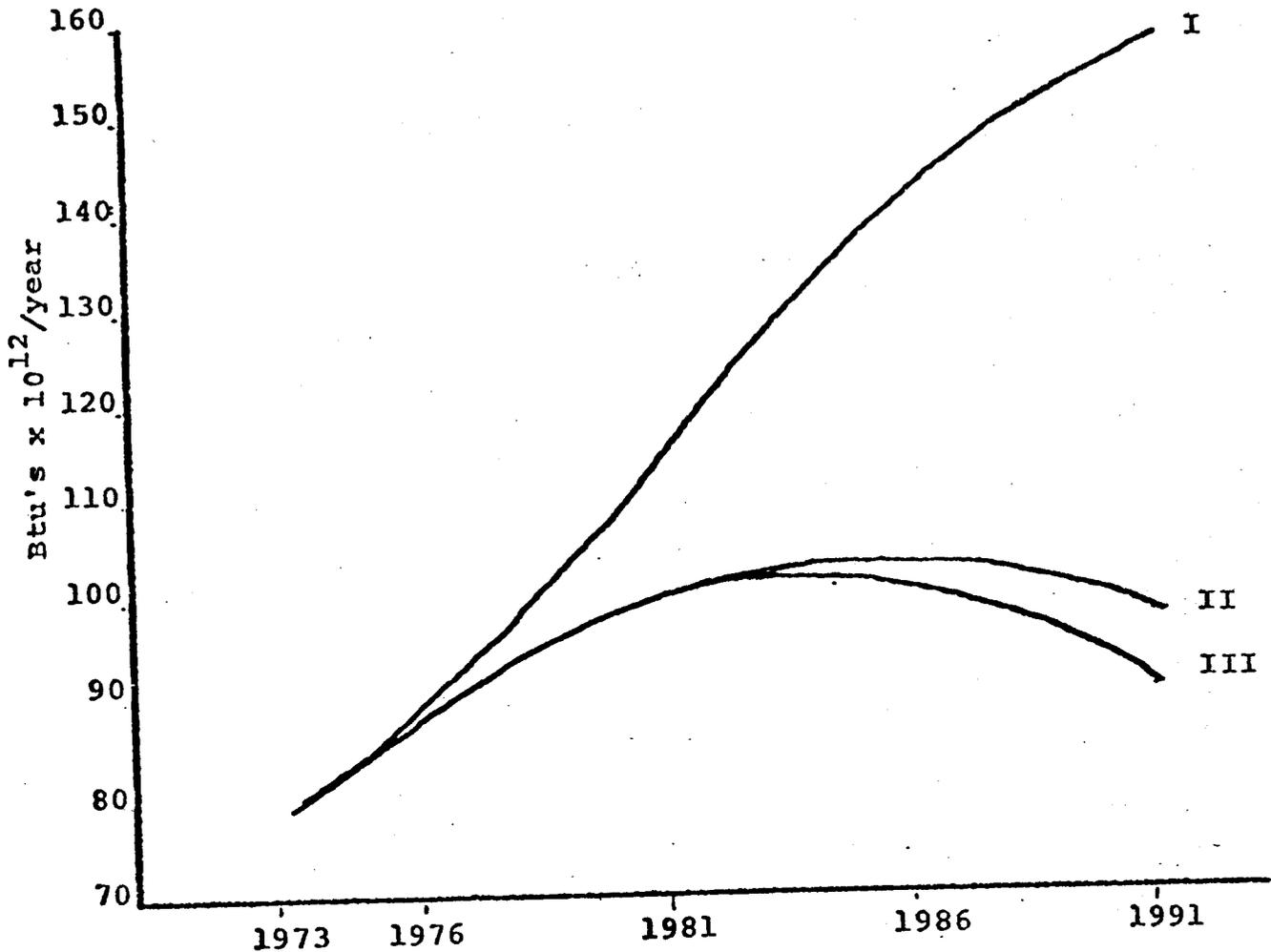

FIGURE 10
ENERGY DEMAND FOR PASSENGER AUTOS



It is clear from these forecasts that large energy savings can be easily attained in this sector with present technologies. This is especially fortunate because motor vehicles are a primary user of B.C.'s scarce oil resources.

Appendix

GROWTH RATES

Canada

1971 - 1975	Crude Oil Production	1.1%
1971 - 1975	Natural Gas Production	4.0%

		EMR	NEB
1975 - 1990	Crude Oil Demand	2.3%	2.1%
	Crude Oil Supply	-2.0%	-4.2%
	Natural Gas Demand (including exports)	1.4%	
	Natural Gas Demand (domestic)	5.2%	
	Natural Gas Supply	-0.3%	(increases to 1985 and then decreases)

World

		CIA	EMR
1976 - 1985	Crude Oil Demand	5.5%	-
	Crude Oil Supply	1.6%	-
1975 - 1990	Crude Oil Demand	-	3.4%
	Crude Oil Supply	-	1.6%

British Columbia

1977 - 1990	Natural Gas Demand (domestic)	4.3%
	Natural Gas Supply	-
1976 - 1991	Crude Oil Demand	3.0%
	Crude Oil Supply	-8.0%

British Columbia Energy Demand By Sector 1976 - 1991

	I	II	III	IV
Residential	2.8%	1.9%	0.9%	-
Commercial	6.0%	4.9%	3.9%	-
Transportation				
Automobiles	4.2%	1.4%	0.8%	-
Total	3.0%	3.3%	4.5%	-

ENERGY CONSERVATION AN OVERVIEW

T.J. Newton, Manager
Energy Services Division
B.C. Hydro & Power Authority

Introduction

The importance of energy to human existence has always meant that fuels have been looked after carefully and used as efficiently as the technology of the time permitted. Our main fuel today is oil, which until very recently appeared unlimited within the normal planning horizons we individually and collectively use, and was almost as cheap as water to produce. Until this decade it seemed that energy was getting cheaper all the time in relation to other commodities. The promise of nuclear, both fission and fusion, suggested this trend would continue and we became lulled into ignoring one of our most vital resources. The decade of the seventies has shattered that sense of security, and forced us to revise our use of energy, giving renewed importance to the concept of energy conservation. I would now like to discuss some of the ideas that are beginning to form the basis for the science, art or phenomenon of energy conservation.

Energy Conservation

The term itself is used widely and seems to mean something slightly different to each person. It means horse sense to some, while conjuring up visions of depression or totalitarian government control for others. To me, energy conservation covers the whole spectrum of ideas that contribute to prolonging the life of finite energy resources, and the optimum use of renewable

energy supplies to meet both short and long term social goals. Having defined my topic so broadly, I would like to explore some aspects in more detail.

Technical-fix

This term was first given wide publicity by the energy policy project of the Ford Foundation. The findings of the project were published in the book A Time to Choose in 1974. The timing was perfect. The project started before the oil embargo and subsequent price escalation, but was at a point where the immediate reaction to this dramatic turn of events could be used to good advantage. The study tried to develop three alternatives described as scenarios. The Historical Growth proposition was supposed to reflect the business as usual pattern of growth in energy. This position was widely held by decision-makers in the energy supply and primary industries.

To provide a counter-balancing point of view, the study also investigated a Zero Energy Growth alternative that envisaged the United States energy requirements reaching a plateau by the year 2000. This proposal includes many of the objectives of environmental and special interest groups opposed to the apparently unlimited expansion of energy supplies. The proposal stated emphatically that it did not contemplate zero economic growth, but relied on the ability to uncouple energy growth and economic growth.

Neither of these two alternatives could be described as an outer limit, but both had sufficient advocates to make them quite plausible. Perhaps in an attempt to produce a compromise, the study developed a third scenario, that of technical-fix. This proposal includes the ideas of improved energy conversion and technical measures to reduce the need for energy without changing the

purposes for which energy is used. Examples include producing more efficient cars, insulating homes and using better designed heating and air-conditioning systems.

Retro-fit

Although technical fixes could easily be introduced in new facilities this still left the present stock of energy using equipment. Under the lower energy growth proposed by the Zero Energy Growth and Technical Fix scenarios, this part of the energy load takes on added importance so that the idea of applying technical fixes to existing houses, cars and refrigerators gave birth to the expression 'retro-fitting'. In cases where the equipment has a short life there is usually little justification for retro-fitting, but in the case of buildings, for example, the possible savings in energy can be considerable. Insulation, storm windows, and insulating jackets for water heaters, are all examples of retro-fitting currently being used quite widely.

Maintenance Measures

Sometimes known as good house-keeping, this is probably the most universally attractive way of conserving energy. The principle is that equipment was designed to function efficiently when installed but wear, dirt or changing conditions have caused the device to waste energy. Ideas that come quickly to mind are servicing private automobiles, changing furnace filters, cleaning the coils of a refrigerator or re-adjusting the heating system of a building after installing additional office equipment such as copiers or computers. At a more complex level, there is increasing use of automatic devices such as

computers to watch energy use continuously and then indicate when the efficiency has deteriorated significantly.

Life-style Changes

Anyone measuring the use of energy soon finds out that only so much variation can be traced to technical reasons. In some cases the unaccounted variation is quite considerable, and can be traced to the way the equipment or installation is used. This life-style aspect becomes a very tempting area for energy conservationists, as the savings are substantial and the direct economic costs are negligible. Examples are reduced temperatures in heated areas or higher temperatures in cooled areas, lower speed limits and reduced lighting levels.

Conserver Society

The life-style changes appear so effective that it is important to study the concept further. I am not sure who coined the phrase but it was through the Science Council of Canada that I first heard of the Conserver Society.⁽¹⁾ Initially it was proposed simply as an alternative to emphasize some of the short-comings of the present consumer society, but the idea became the centre of considerable discussion which was often reduced to social and ethical issues. The Federal Government commissioned the GAMMA Group, a Montreal think tank, to develop the idea further. Three proposals were presented and can be summarized as follows:

1. Doing more with more - a mild technical fix proposal.

2. Doing more with less - a more severe technical fix with some life-style changes. (This approximates the Zero Energy Growth proposal of the Ford Foundation study.)
3. Doing less with less - a major social restructuring which would actually reduce the use of energy when fully implemented.

The positive aspects of the less-with-less proposal are said to be greater individual control over a person's destiny, however, there is also the need for strong regulation to give birth to this type of society. It is this problem of individual freedom versus the central control required to ensure that substantial energy conservation is achieved that will become a central issue in future conservation/supply discussions. The Science Council's recent report seems to follow the more-with-less path, and will provide an important focus for future efforts aimed at conserving all our resources, especially energy.

Why is Energy Conservation Needed?

Now that we know what we are talking about, it is important we examine the reasons given for conservation. Simply assuming that it is a good thing and should be done does not give us the ground rules for judging the complex questions that arise when energy conservation conflicts with safety, employment or monetary considerations. Clearly stated reasons for conservation can bring more fundamental differences of opinion to the surface and allow the most important issues to be discussed.

For Future Generations

Fossil fuels - the coal, oil and natural gas developed about 5 billion years ago; the fossil remains of sun power that fell on the earth during the Paleozoic age - have only been extensively used in the last 200 years and could last, optimistically, for another 300. Time on this scale is so incomprehensible that perhaps the following perspective will help. Let's contract time to "mankind-lives". Mankind was "born" about a million years ago and is now reaching the age of discretion at age 21. On this scale, fossil fuels took 4,000 generations to form. Mankind will use them in four days. It is unthinkable that we use all of our precious 21st birthday present in one four-day binge, hoping that as we wrestle with the hangover we'll discover a new source of energy income to live on.

Perhaps that is too heady for today's discussion, but even on a more imaginable scale today's three year old will be buying a house at the turn of the century. Will we have left her with a fuel she can afford to heat that home with? The issue of whether today's generation should provide the capital for the energy needs of the next generation is at the base of much of the energy pricing policies being presently explored.

To Minimize Environmental Effects

Conservation has been described as the best form of environmental protection. If you don't need the energy, the energy development, production, transmission and distribution systems aren't needed and the environment is left untouched. The solid support for energy conservation provided by such organizations as Friends of the Earth, Sierra Club, Energy Probe, and locally by

SPEC, testifies to this advantage of energy conservation.

The use of energy usually introduces changes in the environment. Air pollution is one particularly pervasive side effect. Fossil fuels ideally burn to form carbon dioxide and water which, in turn, are easily converted by plants back into hydro-carbons. However, there are often sulphur impurities which ultimately produce sulphurous and sulphuric oxides, and at high temperatures the nitrogen in the air combines with oxygen to give nitrous and nitric oxides. These oxides then form acids which can cause adverse environmental effects.

Since all energy ultimately ends up as heat, thermal pollution can be an adverse result of energy use. Energy conservation can reduce all these forms of environmental change.

To Buy Time

The more we delve into energy matters the less we seem to know for sure. Each of the experts you hear from during this series will have to admit to large margins of error; each will close some issues with the remark "only time will tell". Energy conservation will delay the time when the supply and demand lines part company, with demand sailing away from supply. Hopefully, we can use this time to examine the alternatives in more detail, develop superior technical options, develop more appropriate social, political and ethical systems and so make the world a better place. Although mistakes are still possible the probability of a good decision increases with more time for the basic research to reduce the number of unknown factors.

To Provide Security

The oil embargo by the Arba nations showed them the power they had to set prices well in excess of production costs. However, the lessons were not all one-sided, and the oil-consuming nations have not forgotten how vulnerable they are to having their supplies cut. Words like self-sufficiency, self-reliance and energy independence are common in national energy policy statements. Perhaps security of energy supplies has been most dramatically illustrated by the spectacle of the President of today's most powerful nation declaring the moral equivalent of war on reducing dependence on foreign oil, on the basis of a document prepared by its military intelligence agency. (2)

Not only at the national level does conservation provide security. Better insulated homes, for example, will make better use of energy and also keep the heat for longer in the case of energy shortages.

To Save Money

This is of particular importance to the purchaser of energy. Unless he is getting the energy for free there will always be savings from using less energy. Most often the decision to spend money on energy conservation will be based on the savings exceeding the initial cost including such considerations as income tax, inflation and interest charges. Many ideas are attractive in these terms because of rapidly increasing energy costs and the corresponding increases in savings. The short term effects on energy suppliers and the rest of society are more complicated, but very often the effect is still positive if the reductions are fairly small or if they can be anticipated well enough in advance. It is slightly ironic that the same energy supply industries

that stressed the importance of planning sufficient supply to ensure that supply exceeded demand, are the first to blame energy conservation when there is in fact excess supply.

To Reduce Capital Investment

There is an economic law known as the law of diminishing returns. What this means is that as you use more of something useful the less effective each extra unit becomes. This law applies to many situations and now seems to cover the capital needed for new sources of energy. As surface deposits of oil and gas diminish, new wells must be drilled deeper at considerably greater cost per well. New sources of hydro power are more difficult to develop and further from the point of use, requiring more capital for transmission lines. It is estimated that this need for capital will require 25% to 30% of all private investment of a productive nature in Canada according to figures quoted in the report Canada's Energy Opportunities.⁽³⁾ A federal official in a talk last week quoted a figure of \$36 billion for new energy sources up to the mid 1980's. B.C. Hydro anticipates it will require almost \$5 billion over the next five years. Energy conservation allows the economy a longer period in which to generate these astronomical sums. A slower demand for capital allows interest rates to drop, lowering costs and also making funding available for other uses.

Where Do We Conserve Energy?

This is a simple question to answer - whenever it issued, of course. Energy is one of the most pervasive resources available so we are faced with a problem of enormous proportions. The appeal of an Alaska pipeline or Mica dam can drive

hundreds of engineers and construction workers to a frenzy of activity, and yet we hope energy conservation will accomplish the same end result, with hardly anything dramatic to show for it. The magnitude of this task is too great to deal with as a whole - it must be broken into smaller pieces.

Residential Sector

This is a nice clean slice of the whole. The functions we all perform in our castles are similar, so the way we use energy is equally uniform. Each home uses some form of fire or furnace to provide warm temperatures. More fuel is used to provide hot water for cleaning. Energy is used for preparing food and preserving food. Energy is used for cleaning and drying our clothes, and for providing entertainment. Each of these uses must be examined, better habits developed, the effect on our enjoyment of life assessed, and new devices developed which can do the tasks more efficiently. Human motivation must be studied and buying habits researched, so that energy saving ideas are used in our homes. I have described this sector and the needed approach in some detail as this is the simplest case!

Farm Sector

Farms seem to fit between the residential and commercial sectors, and in fact have some factors similar to industry. The farmhouse can be treated as a residence, however, the problem then becomes related to the type of farm involved. Crops require energy to run the machinery used in cultivation, and also substantial quantities of energy in the form of fertilizer. Livestock farms require energy for providing suitable living conditions, supplying food and in many cases

for actually processing the final product, such as milk. Intensive agriculture, such as battery farming or greenhouse operations, usually uses substantial quantities of energy. Some ideas can be applied only to particular processes: for example, a heat pump can extract the energy from warm milk to heat the large quantities of hot water needed in the dairy, while cooling the milk for shipment or storage. Other ideas like insulating barns and greenhouses have more general applications.

Commercial

The Commercial sector always sounds so nice and tidy, but in reality it's a euphemism for "everything else". Banks, offices, supermarkets, warehouses, schools, hospitals, stores and service stations are all examples of energy users included in this category. Each must be identified, examined and specific measures developed. Heating, air-conditioning and lighting systems do show some similarities, and measures aimed at these uses can be applied quite broadly. However, many ideas relate to specific operations. Many office buildings have fairly large computer installations which, in turn, require additional cooling. In mid-winter it should be possible to use the heat from the computers to heat the building. Semi-industrial operations such as bakeries and printers have areas where heat is produced that can be used to heat adjacent areas. The commercial sector is probably a most promising area for energy conservation simply because it is so diverse that a systematic analysis has yet to be completed.

Transportation

The private automobile has been singled out as the one use that will play

the largest role in energy conservation programmes. Because of the major dependence on oil and its unreliable supply as demonstrated by the oil producing cartel, strict measures have been adopted both here and in the United States to assure the improved performance of cars. Small cars are definitely becoming more prevalent and informative labelling is widely used in advertising, hopefully encouraging the introduction of the more efficient models.

Air, water, rail and other forms of road transportation use different amounts of energy to move goods and people at different speeds. The most promising area for conservation is in encouraging the use of the less energy intensive forms of transport. Approaches such as containerisation will hopefully allow each form of transport to be used when it is most suited. Rail transportation presently poses one of the most difficult problems, especially in the United States where rail traffic appears to be losing more and more to road transportation.

Industrial

Industry is a slightly simpler sector to deal with, although the energy savings are extremely difficult to estimate. The industrial user consumes large amounts of energy and therefore is the most sophisticated in his energy use decisions. Price is likely to have a marked effect on energy conservation, so that the general increase in energy costs will reduce consumption noticeably. The level of market activity, however, also dictates energy use to a great extent, both in absolute levels and in relative intensity. What this means is that when there is a strong demand the factory produces more product, and uses all of its equipment. Not only does it use a lot of energy but even the most

inefficient equipment is used. When demand slackens, the older, less efficient equipment is shut down first, so that the energy consumption per unit of output drops, as well as the total energy used.

Tax concessions, specific advice aimed at the particular process, and price increases all promise to improve the energy efficiency of industry. In most cases this will require additional capital, but the capital required will be less than that needed for new supplies. The reason for this is the substantial difference in payback anticipated by industry and the energy supply industry. A new power project can take 20 or 30 years to pay for itself, industry expects its money back in 3 or 4 years.

Who is Doing What

Energy conservation is typically a middle to upper income, developed nation phenomenon. The poor are struggling for survival. The developing nations would love to have the productive capacity of the developed nations in spite of the attendant appetite for energy. The charge of energy elitism now facing energy conservation has yet to be judged.

World-Wide

Most of the energy conservation activity is to be found in the developed nations. One of the best documented reports on these activities is the review by The Organization for Economic Co-operation and Development (OECD), published last year. The main findings were:

1. Conservation accomplishments and progress by International Energy Agency (IEA) nations have been substantial;
2. Nonetheless significant potential still exists for reducing future energy demand in almost every country;

3. The prospects for a continued aggressive conservation thrust in many IEA nations are uncertain.

The report also examined each nation's performance and in the case of Canada singled out the low cost of gasoline, the lowest automobile efficiency, the low urban load factor, and the low energy efficiency of the pulp and paper, and petroleum product industries. The final summary states:

Canada had below average conservation results when compared to the other IEA nations, experiences very poor specific efficiencies in transportation and industry, and has adopted a conservation program that includes some strong elements, but needs strengthening in several areas.

Nationally

Certainly the best energy conservation effort is that being made by the Federal Office of Energy Conservation. Consisting of a highly motivated and energetic staff of engineers, economists, environmentalists and others, the material and reports they have published are prodigious. Such publications as "100 Ways to Save Energy" and "Keeping the Heat In" have been widely circulated, while others provide reference material for those involved in energy conservation programs. The Office tends to maintain a high profile which has earned it many critics within the Federal Civil Service, but which has also allowed it to exert an influence larger than its comparatively small budget and staff would have suggested. It has apparently adopted a 'get the job done at speed' approach which does not allow for much consultation with Provincial agencies although it does sponsor federal/provincial meetings at regular intervals. Often the Provinces are faced with a virtual fait accompli or a take it or leave it option.

Of the Provinces, Ontario has by far the oldest and furthest reaching program, probably because of its dependence on oil and its desire to be independent of the Federal Government. It is often difficult to tell whether a program is federal or provincial in Ontario as there is a definite air of rivalry between the two levels of Government. For example, the energy bus concept for assisting small and intermediate sized industries was pioneered by the Ontario Provincial Government, but was quickly duplicated by the Federal Government.

Provincially

Our own Province introduced a few energy conservation measures within various departments, as early as 1974, however, there was very little coordination or systematic planning. In its 1976 Energy Forecast, the British Columbia Energy Commission included a number of specific energy conservation considerations, but it was only this year that they were provided with the funding needed to establish a major role in energy conservation. The BCEC intends to play a coordinating role using whatever other resources are available within the public sector, and to some extent the private sector, to actually execute programs. It also hopes to play the role of a catalyst in researching and examining energy alternatives. At present the BCEC is acquiring the necessary staff and, I hope, developing overall plans.

Locally

At this point I find it impossible to remain objective since I feel that B.C. Hydro has developed a program that need take second place to no other

known utility. Having said that, I will simply refer to our report describing the more interesting projects selected from about 100 recently completed, currently underway or planned shortly. (4)

The Federal Government has been active locally and this summer saw four of their programs in the Lower Mainland:

1. The Enersave program for residential insulation;
2. Furnace testing for oil furnaces;
3. Energy audits for small businesses;
4. A puppet show on energy, for children.

Many local firms are starting their own energy conservation programs and some of these are most promising. It seems that a common factor in many of these is an enthusiastic individual, who considers energy conservation his personal crusade. A number of public bodies such as schools, universities and municipalities are exploring possible energy management programs. As mentioned earlier, the Society for Pollution and Environmental Control (SPEC) is involved in energy concerns in general and energy conservation in particular, and is currently using a federal grant to develop a school program on energy.

How is Energy Conservation Achieved?

Now that you are all convinced that we should save our energy resources the natural question is, how do we go about it? The following list of alternative strategies is given in order of increasing harshness in infringing on individual freedom. Recent public opinion polls confirm that the measures meet with increasing resistance.

(1) Education:

The basic principle is that once the public is convinced of the need and told how to conserve energy, they will respond. It allows maximum freedom and, unless considered as brainwashing, is not controversial. It appeals to any government or corporate body that is responsive to public opinion, and therefore is widely used. Advertising, seminars, booklets and information programs abound, and the effectiveness depends on the familiar principles used in marketing such as timing, relevance, exposure and profile.

(2) Encouragement:

Education can be made more effective by adding inducements, often financial, to conserve energy. Again the individual's freedom is not restricted, but there is a hidden additional cost to those who do not respond. Tax concessions, government grants, lower interest rates and preferential energy rates are examples. Again they have considerable appeal to public sensitive bodies, but they do introduce the risk that those not participating or not eligible will see the subsidy as being at their expense.

(3) Price:

The increasing price of energy resources can cause direct reduction of energy use by providing a larger incentive to save. There is also the added effect of making substitution more attractive; often additional capital or labour can be employed to reduce energy use. In economic jargon, this reduction in energy resulting from increasing price is attributed to a negative price elasticity. This elasticity seems to show wide variations from one

economic researcher to another, a fact which is to be expected when you bear in mind that all other possible effects on energy use must be excluded or offset.

The pure economist, if such a person exists, would argue that there should be no other form of energy conservation. If energy is priced at its true cost, the normal operation of the market should ensure the optimum use of energy. Such an approach ignores many real problems, such as how the market mechanism works during periods of substantial change and the difficulties of expressing social costs such as environmental degradation, health and security in dollars. There is evidence of growing pressure to increase prices in order to discourage use; however, public opinion polls show one of those interesting quirks that send policy makers to early graves. Individuals think that it is a great idea for the other guy to pay more, but consider it outrageous when they must pay the same high price for their own consumption.

(4) Penalties:

The notion that if high prices work well, higher prices should work better, seems to be the driving force behind penalties. Since there is usually a social stigma attached as well, this can be a most effective strategy when a use is discovered that is generally considered wasteful. Additional taxes for air-conditioning, road taxes based on vehicle weight, additional taxes on automobile gasoline and specific fines can all be used - and many are. However, the target must be carefully selected or considerable opposition will appear. The present acute difficulty Mr. Carter is experiencing in having his energy policy implemented is a clear example of this idea. The elected members of the house are quite prepared to consider the incentive measures, but are firmly

resisting any of the penalty provisos, even when these will apply only in the future, and only when certain conditions are not met.

(5) Regulation:

Penalties still allow the affluent to practice anti-social habits, so regulation seems a more democratic approach to ensuring energy conservation. The advantage is that there is an element of assurance here that is missing in the methods discussed so far. Building codes are perhaps the most topical at present. The disadvantage is the considerable loss of freedom, which, while admittedly protecting us from those who only do the minimum, also makes it more difficult for the inventive to rise above the norm. One further aspect that is very often ignored is enforcement. A speed limit will usually be ignored if there is no enforcement. Building inspectors will have to be trained to determine if a house meets the insulation level specified in the code. This could be an extremely difficult task since insulation effectiveness is closely tied to the quality of workmanship.

(6) Rationing:

When all else fails, energy can be rationed. The loss of freedom is intense, effectiveness is high, and administration can become a nightmare. Such a measure is only likely to be used in an emergency of significant proportions. However, emergencies usually happen quickly and rationing takes planning, so that terms such as contingency plans are becoming common. A recent statement by a federal official from the Office of Energy Conservation that ration books for gasoline had already been printed was received quite

calmly by the audience.

Of course, energy conservation measures do not fit precisely in the categories described, but it is important to realize that there is a spectrum of possible actions, and that the desired level of conservation can probably be attained using different methods, each with its associated financial penalties and limits on individual freedom, and each with a different probability of success. The final strategy will require a trade-off to be made between the conflicting goals.

When Should We Conserve Energy?

(1) At the time we plan our supplies:

Since energy supply is a capital intensive endeavour, interest payments must be made even when the energy they deliver is not used. To benefit from reduced interest, conservation must complement reductions in supply. In the case of depleting resources such as oil or gas, the future value of the resource could still justify its conservation even with the pipelines in place. In the case of renewable resources, such as hydro-electric energy, once the project is built, there is little justification for saving the energy since it will otherwise be wasted. Although there has been very little experience to date, it does seem that demand might be easier to manipulate, in the short term, than supply; but the rule is that supply and demand should be planned together as far as possible.

(2) In time to have an effect:

The logistics involved in wide ranging programs must be considered. It

takes time to design, test, and establish an organization for conservation projects just as it does for supply projects. For example, the insulation financing B.C. Hydro introduced last April was based on employee programs begun almost three years ago. The legal form took two months to develop, and involved about a dozen people, including myself, and yet we ended up with a five part form, with four sheets of carbon, which required a signature on the back! Energy conservation plans must make allowance for these time delays.

(3) In time to allow for social changes:

To change habits takes a long time, so allowances must be made. This is an area that could prove to be the most surprising in the future, however. We all know that many decisions are not justified economically, but satisfy other social needs. If we can introduce the idea that energy waste is stupid or anti-social, there could be quite an abrupt change in energy use.

(4) Start yesterday:

The sooner each one of us starts saving energy the sooner we will benefit. One of the programs included on the information sheet is the well-insulated home program.⁽⁴⁾ These homes are now saving about \$200 a year in energy. At the time they were built the additional insulation cost \$500. Not only has the cost of insulation increased, but the savings have already covered the cost. B.C. Hydro provided the \$500 as part of our research into insulation, since no builder would consider providing the level we requested as a normal feature of the house. Under the new building code those homes will only just meet the minimum standards. The sooner the measures are taken, the sooner the

benefits start and the greater is the total energy saved.

What Can Be Done

The first law of thermo-dynamics is known as the law of conservation of energy. It states that energy is neither created nor destroyed. This means that it can be used again and again. Heat produced by lights and appliances helps to heat the home. Perhaps we could invent a perpetual motion machine that would not require new supplies of energy.

The second law, however, says this cannot happen. Translated, it says that energy has an ability to do work and that this ability does get used up. It is this fact which causes thermal electric plants to have low efficiencies. It is this fact that makes it impossible to get back a cup of boiling water after you have poured it into a bowl of cold water. Since the ability to do work depends on the temperature, one promising idea is to use the high temperatures to produce mechanical and then electric energy and then use the energy at lower temperatures to heat homes and hot water.

Finally, let us see how much energy can be saved using some of these principles. Figure 1 illustrates the nature of the savings that could be achieved by such projects as the B.C. Hydro HUDAC-PNE Energy Conservation Home.

¹ Science Council of Canada. 1977. Canada as a Consumer Society: Resource Alternatives and the Need for New Technologies. Report No. 27, Ottawa.

- ² U.S. Central Intelligence Agency. 1977. The International Energy Situation: Outlook to 1985. Pub. No. ER77-102400, Washington, D.C.
- ³ Science Council of Canada. 1975. Canada's Energy Opportunities. Report No. 23, Ottawa. See also, F.H. Knelman, 1975. Energy Conservation. Science Council of Canada, Background Study No. 33, Ottawa.
- ⁴ B.C. Hydro & Power Authority. 1977. A Report on B.C. Hydro's Energy Conservation Programs. Vancouver.

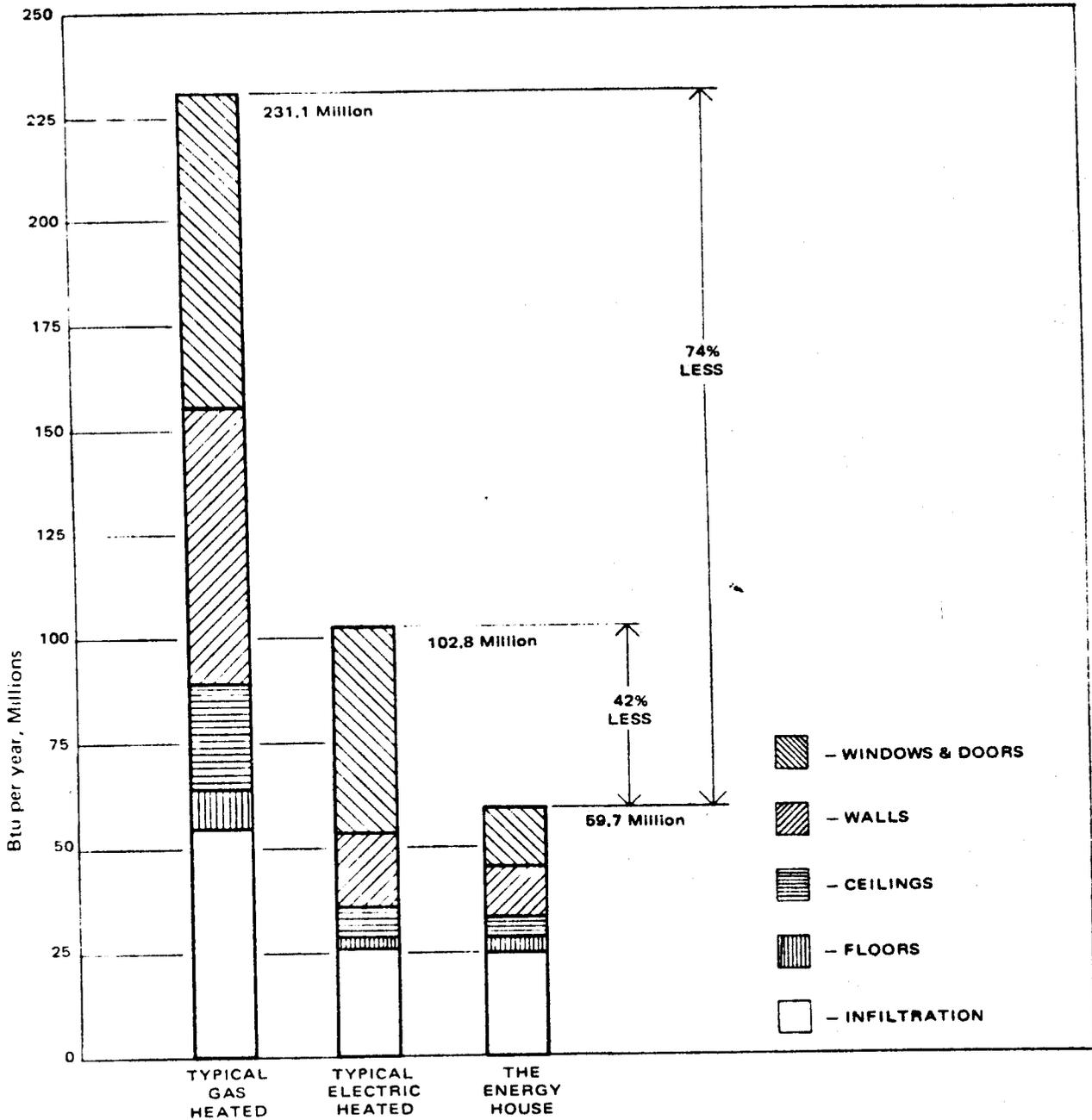

ANNUAL HEATING ENERGY PROPORTIONS

Figure 1 above illustrates the contribution of better insulation levels to energy conservation. These improved insulation levels are readily available at reasonable cost.

Source: Report on the B.C. Hydro HUDAC-PNE Energy Conservation Home.
Energy Services Division, B.C. Hydro, July 1976.

THE FUTURE OF OIL AND GAS IN CANADA

H. Maciej
Technical Director
Canadian Petroleum Association

This particular lecture series deals with one of the most critical issues, not only facing Canada, but mankind at large and so I am personally grateful for the opportunity to participate in this discussion and I hope I can make a contribution toward understanding of what is facing us in the decades ahead. I also want to commend you personally for enrolling in this lecture series; the collective understanding of the long term energy situation by the public at large is one of the most critical issues in arriving at a solution. Any transition in our economic life as momentous as the one the world now faces is bound to cause dislocations, and will not be without pain. The Conservation Commission of the World Energy Conference, in a recent draft report, stated:

Among all the obstacles separating the technical possibilities of petroleum production from the effective realisation, the most difficult to surmount is failure to believe that they exist. The scale of investment necessary requires that the general public should be convinced that the problems confronting it are real and should be willing to help solve them. The amount of information published on the subject in the last three years and the present abundant supplies even if people are beginning to recognise that these are temporary and largely artificial, have created an almost universal skepticism with regard to the problem of petroleum resources. What can be said now to make people believe in it? Will some event that interferes with the daily lives have to occur for them to be convinced? Should we after all hope that such an event does not come too late.

This indicates that public apathy is world wide, and I don't suggest that we take any comfort from it. In view of this public attitude one wonders, therefore, what merit there is in any attempt to discuss the future of energy supply, especially since any positive statements are sure to evoke an outcry depending on whose ox is going to be gored. Nevertheless, I believe discussion

must be continued for the same reason that previous talks have been held, namely a forlorn hope that somebody is going to listen. Each time, I suppose, every speaker actually believes that something truly significant is going to happen as a result of his warning with regard to the limits of future oil and gas supplies. This type of forecast not only shares the low credibility of all forecasts, but probably more importantly, it contains unpleasant thoughts and we do not want to hear anything unpleasant. Neither Canadians, nor Americans, nor the Japanese or Europeans really believe that their standard of living is in jeopardy. We have always had unlimited supplies of energy, therefore (and note the unpredictable logic) we always will.

I don't think we can discuss the Canadian situation in isolation and so with your indulgence let me discuss first the global aspects and then zero in on the Canadian situation. The energy situation certainly is in an upheaval and some extremely important events are in the making, not just here in Canada but also in the United States, and on a global basis.

When OPEC put the industrialised world into a state of shock by quadrupling oil prices, the major concern was the real transfer of wealth from the industrialised nations of the world to OPEC. The problem seemed to be how to come to terms with the OPEC capability to buy up western businesses, the backbone of our way of life and standard of living. After taking care of their domestic programs, the money left over to OPEC was running at about sixty billion dollars a year. That equates to roughly seven million dollars an hour or one hundred and fifteen thousand dollars a second. At that rate OPEC could have acquired the equity of all companies listed on all the world's major stock markets in about fifteen and a half years. With the income of only seventy nine days they could have acquired EXXON, the world's largest oil company.

To take over British Petroleum they only had to save their nickels and dimes for fifteen days. At the height of the concern one OPEC country bought fourteen percent of the equity of the renowned German firm of Daimler Benz - two days of savings was all that was needed.

Needless to say it sent shivers down the spine of the industrialised world. Economists everywhere agreed that OPEC had us by the proverbial, and while we are still faced by disturbing world wide trends in current account deficits, inflation and unemployment, I believe we are coming to grips with the problem of adjusting to the real transfer of wealth to the oil producing countries set into motion by those massive price increases back in 1973. Three years of ups and downs have since gone by. The economic situation in numerous countries has passed through serious crises and no one is yet sure that the end has been reached. Actually the OPEC governments have done a good deal in the last two years to ensure that their surplus cash was not being immobilised but used to lubricate the wheels of the world economy. A recent report by the U.S. Treasury Department indicates that OPEC's surplus of \$135-\$145 billion is finding its way back into the industrialised economies and also, more importantly, into the less developed countries. In recent months the portion of the flow back going into long term investment, with an emphasis on debt securities, has been growing significantly.

Looking back, I would have to say we became somewhat pre-occupied with the transfer of wealth aspects and overlooked the real issue. It appears to me now that the Arabs made that assessment back in 1973 when they had to appraise the possibility of success or failure of the pricing action. In re-reading some of the statements made by OPEC leaders at that time, perhaps their statements with regard to the future world oil supply were less glib than our criticism

There were a number of studies available that predicted that sometime in the 1980's oil needed will exceed oil produced. But since most of these reports had been prepared by oil companies they were being disregarded as being self serving.

It was not until President Carter in his April 20th speech endorsed the CIA Report that by 1985 there will probably not be enough oil to go around that the message began to sink in. One can argue the precise date since figures for oil production and consumption eight years hence are only a best estimate. But it doesn't matter: if not in 1985 maybe in 1990. Or even as early as 1983? Amongst my own peers, some are very critical of the CIA Report as being far too pessimistic. They firmly believe that there is a lot of oil left to be found and I agree with them. The problem, however, is, can we put enough of it on production to meet the growing consumption. This is what the CIA study tried to assess. Their report intended to show what present world conservation and production policies would achieve. The CIA was not unique in its finding when they concluded that the world cannot save itself out of the tight supply situation approaching. The fact is that we are using more oil than we are finding and we are thus eating into existing reserves at an accelerating rate. The rate of oil discoveries has averaged fifteen to twenty billion barrels per year since the 1940's. The major portion of this oil was found in the Middle East.

The first oil in the Middle East was discovered in 1908 in southern Iran. For nearly twenty years Iran was the only producer until, in 1927, oil was found in Iraq, then in Bahrain and later most importantly, in Saudi Arabia. Since then oil reserves have increased dramatically from 214 billion barrels in 1965 to more than 370 billion in 1976, and now comprise almost 60 percent of

the world's total. In the past ten years discoveries outside the Middle East have steadily increased - both in pursuit of supply diversification and because it appears that most of the major fields in the Middle East have already been found. The world finding rate has also dropped in recent years. If we assume that the future finding rate in the non-Communist world will average 15 billion barrels annually, it is easy to foresee the day when we are in trouble since our consumption rate is rapidly moving toward the twenty billion mark. As production exceeds new discoveries by greater and greater amounts, the reserves we have built up particularly over the past twenty years will shrink. And so we face the distinct possibility that by the late 1980's oil supply, and therefore consumption, will be limited by the availability of discovered reserves.

When we look at productive capacity the prospects look even worse. At present OPEC has potential spare capacity of about six million barrels a day. I should emphasise "potential" spare capacity because some OPEC nations have put production limits on their oil fields and will not allow maximum production. In terms of replacement, the North Sea experience has shown that much longer lead times are now at play in placing new production on stream and so the spare capacity is going to disappear very quickly. Time has become one of the most critical factors. No matter how much oil is in the ground we will not be getting enough out to meet demand regardless of what the reserve situation is.

The final report of the MIT workshop on alternative energy strategies arrived essentially at the same conclusions as the CIA report. The report warns us that failure to shift reliance on oil could result in major political and social disorders as energy becomes a focus for confrontation and conflict. High prices and unpredictable competitive forces for oil supply would inevitably depress world economies. Will there be enough goodwill left between competing

nations to bridge the critical period until we develop a less oil dependent world economy? I invite you to ponder that question.

Another study dealing with the world oil situation that made the headlines in recent months was the U.N. report resulting from last summer's UNITAR Conference held in Austria. The U.N. study concluded that the world's oil supplies may last a hundred years or more if reserves are effectively exploited. Our hip-shooting media critics immediately condemned the findings of the CIA Study and later questioned the MIT Workshop Report on the same basis. Actually, there is no conflict between the three reports. The principal difference between the CIA-MIT reports and the UNITAR report is that, whereas the first two emphasised increasing world consumption versus relatively finite production capabilities, the UN Study was premised on increased production, albeit at substantially higher cost. The Report stated that there are significant resources yet to be discovered since "most of the world, particularly in the developing countries, offshore and on the ocean floor has never been systematically explored for oil and gas." The UN study took into account in its projections, improvements in technology (secondary and tertiary recovery methods) and the development of non-conventional resources such as heavy crude oil and oil from the tar sands and oil bearing shale, although uneconomical to produce at existing price levels. In the latter category the U.S. alone is estimated to have some 1.8 trillion barrels of proven reserves in oil shale deposits. Canada, of course, has some one trillion barrels of bitumen in place in the Alberta oil sands.

The most recent study that has come to light is the report of the Conservation Commission of the World Energy Conference which was unveiled in its draft form at the Xth Congress in Istanbul in September. I was fortunate to participate in the deliberations. The findings are no different. Perhaps

the amazing part was the amount of agreement amongst the world's foremost experts which were asked by WECO to give their predictions in a delphi-type poll. Two-thirds of those people polled clustered around an estimate of two trillion barrels for the ultimate recovery of oil in the world. But like any other estimates of this type it was not without dissenters. The highest estimate was 3.7 trillion and the lowest 1.6 trillion. But again the inevitable conclusion was that sometime between 1990 and 2010 demand will outrun production; the timing will depend on growth and demand and any political action to hold down production and many other factors.

In the midst of this atmosphere of gloom arising from the predictions about impending energy imbalances as soon as the early 1980's, the energy ministers of the nineteen industrialised nations (excluding France) which make up the International Energy Agency met last month in Paris. The mood of gloom of that Conference was contrasted by the current world market mood engendered by a surplus of oil supply over demand, rising oil stocks in leading consuming countries and the resulting selective price cutting by several OPEC members. Frankly, the governments represented at the IEA meeting have taken little positive action since the 1973-74 oil crisis, but on the surface at least it looks like the message is beginning to sink in. The ministers adopted a program of conservation and alternative energy measures aimed at reducing dependence on OPEC oil. The weakness perhaps is that the program is voluntary and no crude oil import targets were set for individual member countries.

Against this global background let me now move on and discuss briefly the U.S. Energy situation and particularly President Carter's energy plan as presented to Congress on April 20th. The massive plan, which Carter implied would be the "moral equivalent of war" on the energy crisis facing the U.S., attacks the energy problems through a major conservation effort to be realised

through such mechanisms as sizable taxes on gas-guzzling cars, tax credits for home insulation, a standby gasoline tax, phased price increases for crude oil to 1977 world prices through a complicated oil tax system etc. President Carter's heavy emphasis on energy conservation did not come as a surprise to international observers of the energy scene. The American waste of energy has encountered increasing criticism from her allies and trading partners. Some have accused the United States of hastening the day of the inevitable oil crunch through the wasteful and inefficient use of energy. I am sure that the President's energy message and his forthright attack on the profligate American waste of energy was designed to pacify some of the criticism. Personally I judged the President's message as being extremely timely and important. It is a very ambitious program (113 separate proposals), yet it has some serious deficiencies.

You will ask why should we be concerned about the American energy program. The reason is simple. Whatever they do below the 49th parallel is going to impact directly on our own situation. For example, U.S. pricing policies will determine our own government's course of action. Mr. Gillespie has repeatedly stated that Canadian oil and gas prices will move towards world levels but, and this is where the U.S. enters the picture, under no circumstances can Canadian prices be allowed to exceed U.S. prices. I have a certain amount of sympathy for this proposition but two wrongs don't make a right. There are different ways of skinning the same cat.

What really surprised me about Carter's energy plan was that I thought it was totally un-American. I expected that the President would opt for the traditional American way and would mobilise the enterprising spirit of the American entrepreneur to find a way out of the dilemma. Instead the President tried to justify his approach by saying that an effective and comprehensive

policy is possible "only if government takes responsibility for it." Ladies and gentlemen, that is not going to work in the United States, nor in Canada, nor in Germany, or for that matter in any industrialised nations of the non-Communist world. Regulation is never going to be the answer or solution to our energy problems.

We know from the publicity and newspaper reports the President's program still has a hard road ahead. Numerous changes have already been made, many more are needed to arrive at an effective plan. Hopefully the tight regulatory leash on the private sector will be loosened to allow the oil industry to respond to the dynamism of the market place. The Oil & Gas Journal in a recent editorial severely criticised some aspects of the government's control plan:

Suppose Jimmy Carter the farmer were asked to design a scheme to stimulate peanut production. Would he slap a lid on prices for all peanuts except those produced in fields ploughed for the first time after April 20th 1977, located no closer than two and a half miles to any other fields existing on that date, and planted at least a thousand feet deeper. That makes no more sense for peanuts than it does for petroleum.

It is important to us in Canada, and to all the other industrialised nations, that the U.S. solves her energy problems particularly in the light of the anticipated tight world supply situation which I discussed earlier. The U.S. now imports just under half of the oil it consumes, that is as a single customer they buy one-third of the total oil exported in the world. This illustrates the magnitude of impact that the U.S. situation has on the global picture and it is understandable that those economies that must rely on imported oil are apprehensive about the political and strategic consequences if the United States do not find a solution. That brings me to the Canadian scene.

You are going to hear about Canada's energy strategy now entitled,

Policies for Self Reliance, from Gordon MacNabb in the next few weeks I understand. I wish he had been here last week and told you all about it. It may have made a difference as to how you view what I have to say in the next few minutes. Let me look at Canada with a different slant. Before I do so I would like to direct a few comments to an issue that appears to have been overlooked in the current debate in Canada. I am referring to the role the petroleum industry can play in securing for Canada a place of unequalled strength in coming decades.

Since the dawn of the new energy situation in 1973, nations throughout the world have been forced to adapt to the reality of higher prices, the prospect of diminishing oil and gas supplies and an energy crunch, possibly as early as the mid-1980's. The reaction of governments to this reality has varied from country to country. But one fact sets Canada apart from the rest. If you place to one side the OPEC nations, and one or two others like Great Britain and Norway that have recently been developing new indigenous oil reserves, Canada stands out as one of the privileged industrialised countries in the world with the potential to become self sufficient in oil and gas supplies. Indeed, I would not hesitate to revive an old cliché and suggest that the next quarter century belongs to Canada simply because of our energy potential. Should Canada be successful in translating potential into reality the implications will be broad. In the first place Canada would remove itself from the world market as a bidder for a resource that will eventually diminish. The beneficial impact of such a move would be dramatic. Just imagine an economy based on domestic energy supplies while competitors abroad sought energy not at a high price but at any price. As a businessman and as a Canadian I believe that the pursuit of energy self-sufficiency can be an important force to pull this country together

and retain all its components. The price of energy self-sufficiency is our quality of life, security and jobs, and avoidance of social upheavals that are bound to happen in energy deficient nations when the crunch comes.

Let me now outline why I believe Canada has this unique opportunity. Four years have passed since OPEC action not only changed the structure of the petroleum industry but of the entire world economy. Virtually overnight governments all over the world were forced to adapt to the new situation. They did so through new policies that varied over a wide range. Some used shock treatment and their national economies simply had to adjust without transition. Others opted for cushioning the impact through price controls, subsidies and other measures. Because of our substantial indigenous production, the Canadian government opted for a mechanism to hold Canadian crude oil prices below world levels through an oil import compensation program. Under this program importers of foreign oil pay the full world price but are reimbursed for part of the cost. By this means it has been possible to assure similar crude oil prices in all parts of Canada. But let me hasten to add this policy has contributed nothing towards the solution of the energy problems controlling us. The principal of a single national price was established by the federal and provincial governments early in 1974. This policy avoided serious distortions in the cost of energy between regions in our country. We in the industry endorsed this policy as one that was in the interest of Canada and national unity. While there were other options we believe that this policy has brought about acceptable results and is certainly commendable when we look at some of the confused and contradictory policy actions taken by some other countries.

It is important, however, to realise that the economic price of the

Canadian policy has been substantial and would continue to grow if our crude oil prices were not moved to world level. Over four billion dollars have already been paid out under the Oil Import Compensation program. The main beneficiaries have been the Maritime Provinces and Quebec, and to a lesser extent, Ontario. The revenue receipts from the Oil Export Tax generated from the sale of crude oil to the United States at international prices provided the major portion of funds for the compensation program. But with Canadian conventional oil supplies declining, exports are being curtailed and revenues are falling accordingly. That Canada could not afford to subsidise oil imports indefinitely and depress domestic price levels has been apparent for some time, and the recent pricing action, to move the price up in an orderly fashion, was the proper response. While higher prices will never be popular with the consumers it provides us with a unique opportunity to solve our future energy supply problems.

The National Energy Board has told us that a shortfall in supply of indigenous oil to meet the demand in Canadian markets now supplied with Canadian oil will almost certainly occur between 1981 and 1983. Domestic oil supply is expected to fall short of requirements in those markets by about 450,000 barrels a day in 1985. The Board also said that imported oil will be required in the early 1980's in areas that are now served by indigenous crude and so we are even looking at a reversal of the oil pipeline recently extended to Montreal.

The outlook for natural gas despite the present surplus and deliverability is not that rosy either. There is no room for complacency. In its recent decision the National Energy Board found that a pipeline to transport Mackenzie Delta gas to Canadian markets will be needed during the first half

of the 1980's. The NEB concluded from its supply and demand assessment that there will be a need for additional gas for Canadian markets over and above that forecast to be available from the southern area to meet the "most likely" forecast of Canadian demand plus existing export commitments as early as 1981 or as late as 1985 depending on certain policy options open to the government.

Exploration for natural gas is progressing aggressively in Alberta and British Columbia. The industry's effort has been accompanied by success and we have been able to replace production and add to our reserves. We can currently deliver more gas than the established markets can absorb. In this connection it is important to observe that the market for gas in Canada outside Alberta has been almost stagnant in recent years. It is understandable that users will not contract for gas supplies without a five to ten year guarantee of supply. Customers need assurance that their investment is going to be protected for its life and that long term supplies will be available if they decide to heat and run their business or factory on natural gas. This assurance was not possible until recently but the industry's exploration success together with the assurance that there will definitely be a delivery system for the gas discovered in the northern frontier regions has changed this. Prospective users of natural gas can now be assured of long term supplies.

We must, however, recognise the tough interfuel competition that exists in the marketplace, particularly in the industrial sector. It is one thing to propose extension of the gas delivery system beyond Montreal to the Maritimes. It is another to develop a base load which would have to come from the industrial users to make such a pipeline economically viable. At the moment it is almost impossible to predict the eventual use pattern that will exist after the marketplace has sorted out the ramifications of higher gas prices and the

complex relationship in the fuel oil sector caused by changes in yield patterns and requirements.

Clearly, any oil scarcity situation would have a traumatic effect on the economy of our country and the rest of the industrialised world. Reduction in energy use will come at the expense of employment, which in turn indicates social upheaval. There are ample historic precedents to look at in order to predict the repercussions. A slumping economy in Germany, Japan or in the U.S., our most important trading partners, could be really difficult for Canada. But at the same time we must not overlook the opportunity to strengthen our own position. Even if OPEC is willing to meet the higher demand and thus delay any shortage and avoid a bidding war, the impact of large oil imports on the Canadian economy and balance of payments could be disastrous.

It is reasonable to predict that OPEC oil prices will continue to rise at a minimum at the average inflation rate of the OECD countries. The experts predict that this rate will not drop below 5 percent until 1985. This means that the laid-down cost of OPEC oil in Montreal will be about \$22.00. If we accept the NEB's "most likely" case projection for Canada's import oil needs of one million, one hundred and fifty thousand barrels daily it would mean a foreign exchange bill of over nine billion dollars in 1985 and, if nothing is done about it, the bill could increase to about thirteen billion by 1990. I have no idea what this will do to the value of the Canadian dollar, but it would be reasonable to speculate that it would be much lower than today with such a balance of payments deficit.

What are the options? What is the petroleum industry doing about it? Exploration activity last year set a new record and this year's expenditures will be at least one-third higher. Unfortunately the all out effort does not

encompass all regions. Actually, some of the most promising areas with potential for major discoveries are idle. The Labrador shelf is tied up in a jurisdictional dispute, in the Mackenzie Delta drilling has slowed well below expected levels. There has been public concern expressed about our industry's willingness to reinvest the gains from higher prices. The fact is that last year the petroleum industry's reinvestment in exploration and development exceeded cash flow from operations. The difference, of course, had to be made up from new borrowings, some equity issues, drilling funds, government incentive schemes such as the Alberta ALPEP program, injection of funds through Crown corporations, and investment in the Syncrude Project. And so the record speaks for itself. Just looking at the competition at recent government land sales leaves little doubt that the all out effort to find the remaining undiscovered conventional oil and gas supplies is in high gear.

As the international oil price rises it affords Canada with a unique opportunity, an opportunity that is probably not available to any other industrialised nations, to solve our future oil supply problem. I am of course referring to the oil sands and heavy oil potential that we have in Canada. In the combined heavy oils in the oil sands area Canada has over one trillion barrels of known oil deposits in place. It provides the opportunity and the challenge. Realisation is confronted with an economic and technological frontier. Time also is a vital factor. But we must face the challenge because any other oil related energy options have all but been exhausted and, as I pointed out earlier, greater reliance on imported oil courts economic disaster for Canada.

Now let us make no mistake about it; they will be high-cost supplies.

The capital requirements will surpass anything the petroleum industry has faced before. It will change the nature of the industry and it will also require drastic and innovative changes in government policies, particularly in the fiscal sector. We may have to develop means of raising capital never thought of before. We can mine oil from the tar sands today at cost which would be competitive with the price of imported oil. A third mining plant could be viable but the extent of direct contributions to government fiscal take from such a project will need to be reassessed. The cost of the next plant including capitalised interest during construction will probably run in the order of four billion dollars or forty thousand dollars per barrel of daily capacity. Full production from such a plant cannot be expected until past 1985. Construction of a commercial size Cold Lake in situ project could parallel the third mining plant and the capital requirements will be of similar magnitude. Large scale testing of in situ techniques is under way in Alberta. In the order of half a billion dollars are now dedicated to this phase. Considerable assistance in funding has come from the Alberta government, particularly through AOSTRA, but also from the Federal Government through tax write-offs that allow us to defer income tax obligations. Unfortunately these are projects with very long lead times. It takes about three years to build a pilot plant, another five years will be needed to test technology and the scale up to commercial production will take many more years. Thus, any sizable contribution to indigenous oil supplies will probably not be seen until the second half of the 1980's. The progress that has been made in this field is certainly encouraging and the number and size of pilot projects is increasing. Experimental crude oil production in Alberta, although still modest, has increased ten-fold in the past ten years. Last year output more than doubled from 1.3

million barrels to 2.7 million barrels. This year we expect that experimental projects will produce about 4 million barrels.

There is a possibility for fairly early additional oil supplies, namely production from our extensive heavy oil reserves in Alberta and Saskatchewan. Two consortiums are investigating the construction of upgrading plants. An engineering study is underway for an upgrading plant which could provide an extra 100,000 barrels a day of premium feed stock for Canadian refineries. Again it is a costly proposition requiring a new approach to financing and economic viability. We are probably looking at 500 to 700 million dollars for the upgrading plant plus a back-up investment in the neighbourhood of one and a half to two and a half billion dollars. Discussions with the federal and provincial governments have been encouraging and hopefully the first plant will be approved soon. Here we are dealing with known technology which will shorten the lead time. We can thus beat an expansion to the Syncrude plant or the completion of the third mining plant for an earlier start up and be operational by 1981.

All the projects I have mentioned are high cost in nature, but surely it makes more sense to begin developing even these high cost resources than to continue paying the increasing cost of imported oil which would merely mean a transfer of our people's wealth to OPEC. I also want to mention the possibility of increased production to enhance exotic recovery schemes. Industry is not neglecting this area. Encouraged by the recent change in the royalty treatment of such projects in Alberta and British Columbia, industry is now looking at several possibilities. The availability of funds from the newly created Federal Saskatchewan Research Fund has also encouraged pilot projects for tertiary recovery in the heavy oil fields of Saskatchewan.

If I look at the options open to us I can see the opportunity for our nation, not only for greater self-reliance in oil supplies but for self-sufficiency. The resource base is there; we only have to turn it into flowing supplies. The capital required doesn't frighten me. Most economists agree that it will be well within the capacity of the Canadian economy. The producing provinces are channelling substantial amounts of their oil and gas receipts back into the petroleum sector through incentive programs and contributions towards research to overcome technological barriers. The federal government is playing an important roll by providing a fiscal regime that encourages aggressive action by the private sector. But that may not be enough. The consuming provinces may yet have to assume a more prominent roll in providing the necessary capital. I would like to define this part more clearly but I can't.

Our objective should be to maximise new oil supplies from the oil sands and heavy oil areas complementary to accelerated exploration and development of gas in the frontier and the established southern regions. All of these supplies will be needed. This must go hand in hand with a determined effort for energy conservation and elimination of all energy waste. The alternative is an increasing dependence on imported oil. As I mentioned earlier forecasts of the world energy situation are such that Canada cannot afford to enter into a bidding war.

In summary, we need a fresh look at our energy position against the background of the new global situation which is now beginning to shape up. When I suggest that we review our strategy for self-reliance I recognise the challenge we face. Let's first acknowledge that in terms of world prices our indigenous oil supplies have always been on the fringe of the marginal cost.

The OPEC price hike actually moved much of our potential supplies into the range of economic viability provided that the fiscal take is reasonable. The fact that our new oil and gas supplies will be high-cost resources and will only be able to enter the marketplace at substantially higher than current prices received official government recognition in the last green paper. Indeed, the era of cheap energy is over.

I am confident that our industry is about to break the technological frontier. The conquest of the economic frontier will depend on new and innovative fiscal policies to create an investment climate that will generate the necessary capital. The petroleum industry has always been capital intensive. The future needs, however, will surpass anything we have faced in the past. We need energy policies that are stable and long term, and that does not imply complete inflexibility which would hinder reaction to new and unexpected circumstances. For a high risk industry such as the oil and gas business, where short term returns are usually not obtainable, uncertainty must be minimised. The excuse so often used by our politicians, that they cannot commit future governments, is no longer acceptable. Take an oil sands mining project as an example. During the time it takes to plan, construct and put on full production, such a project, we may have three or more changes in federal government and a like number of elections in the province. How can anyone be expected to risk four billion dollars without stable legislation? And so I would propose that all key factors be anchored in legislation itself and not be left up to regulation (which can be changed almost at will) or ministerial discretion, and that subsequent governments don't tinker with the established principals. We also need to remove any arbitrary pre-judgement of what constitutes a reasonable rate of return or

profit.

Agreement between governments and the industry about what is and what is not an adequate rate of return will always be difficult to achieve. Each will usually suspect the others motives. The happy mean cannot be determined in advance; it will be determined in the marketplace. It is a level that brings forward the required investment without leaving that industry's profit out of line with those of other sectors of the economy. The ultimate test of a reasonable rate of return is whether market conditions tend over time to equalise the attractiveness of investing in different industries. No government and no bureaucrat is smart enough to determine that in advance.

Let's also acknowledge one basic principal that makes our industry tick. An integral part of the industry's perception of exploration as a fair gamble has always been the powerful lure of the "big strike". This "bonanza effect" operates in the oil industry as it does in any other activity in which there is a wide dispersion of individual returns around the average. Men eagerly invest in activities in which there is a small chance for a big price, even when they know in advance that the average return is negative. And if you doubt that proposition I invite you to spend a few hours observing the action in Las Vegas. Any successful lottery operates precisely on that same principal. The consumer as well as the public interests have benefited tremendously from this particular characteristic of the petroleum industry. Why kill this powerful incentive? I would put it to work.

When I look back at our country's short history I see a continued chain of challenges to a nation that many contend should never have been. We survived the past and the future is ours if we don't back away. I hope we have that determination while there still is time. Upon the Scandinavian Peninsula, up where Norway, Sweden and Finland come together, lives a tiny

animal, a distant relative of the field mouse, called the lemming. From time to time these creatures experience a population explosion and when that happens thousands of these animals migrate across the upland surface in a search for food. They have poor leadership. When they come to a cliff overlooking the sea, over the cliff they go. Those who have a high I.Q. say, "My god, we are going to drown!" But not the ones behind them on the upland surface. They say, "I don't see any cliff!" Let's try to avoid that cliff.

COAL AS A MAJOR ENERGY RESOURCE

E.R. Macgregor
Assistant Deputy Minister
Ministry of Mines and Petroleum Resources

The development of industrialized society throughout the world has been dependent on the ready availability of low cost energy. Coal was the principal energy source for the Industrial Revolution which, in North America began in the 1860's. By 1910, it supplied 90 per cent of the demands of the energy market in the United States and in 1950 it still accounted for 40 per cent of that country's energy consumption. A similar growth pattern developed in Canada. Since the Second World War, the relative position of coal as an energy source rapidly declined as petroleum and natural gas became the dominant fuels for transportation, space heating, and industrial processing. By 1972, coal use in Canada had been confined principally to power generation and coke production, and accounted for only 10 per cent of the national energy supply. Petroleum and natural gas however, supplied 44 per cent and 19 per cent, respectively, of Canada's energy demands (see Figure 1).

The Middle East war in October 1973 and the actions of the Organization of Petroleum Exporting Countries (OPEC) in 1974 dramatically focused world attention on the heavy dependence that had been placed on imported oil as a low-cost energy source. Since that time, all countries have undergone significant readjustment to the economic pressures caused by higher energy prices and the resultant balance-of-payments problems, escalating rates of inflation, reduction in real economic activity, recognition of the finiteness of non-renewable energy resources, and awareness of the need to develop and adapt to new energy

FIGURE 1

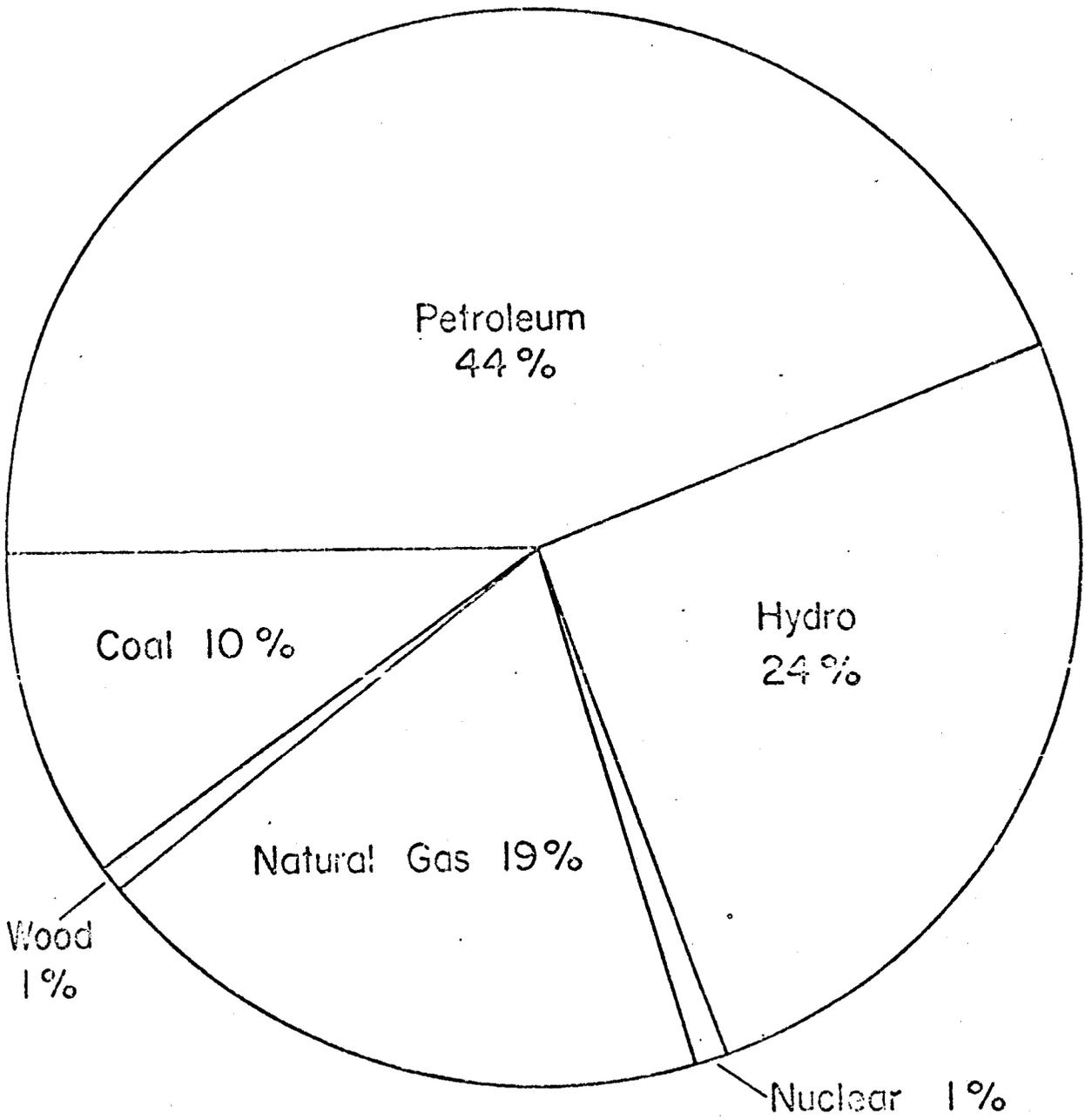

CANADA

systems on the longer term. For the next half century and beyond, Canada and other industrialized nations will face a continuing challenge to balance energy supply and demand in a way which involves the least economic, environmental and social disruption. During this period, industrialized society must shift from its almost total dependence on non-renewable resource (particularly oil and gas) to a more appropriate mix of energy sources. One of the most important means of providing an orderly transition to a greater reliance on renewable energy sources is to make optimum use of the world's large coal resources. Canada is very fortunate to have significant coal resources, which when balanced with petroleum, natural gas, uranium and conventional renewable resources such as hydro, can permit this transition to be made effectively.

During the Tenth Triennial World Energy Conference held in Istanbul in September 1977, it was indicated that if industrial development is to continue at even "modest" rates of about 3 per cent per year, energy requirements are estimated to increase threefold between now and the year 2020. For "high" economic growth of about 4 1/2 per cent per year, energy demand by then could be four to six times its present level. Yet gas and oil reserves are thought to be such that from about 1990 onwards, output will be unable to meet demand unless there is a major switch to alternative fuels. Thus coal requirements are expected to increase sharply, especially after the mid-1980's, to between four and six times the present level by the year 2020. Coal output in the world's eleven leading coal-mining countries was thus forecast to rise from 2.2 billion tons in 1975 to about 8 billion tons by 2020.

In 1976, Energy Mines and Resources Canada published, "An Energy Strategy for Canada", which forecast a 94 per cent increase in the total Canadian demand

for energy by 1990 (see Figure 2). However, coal is expected to supply an increasing share of that energy demand, and will increase 136 per cent from the current consumption of 28 million tons per year to about 66 million tons in 1990 (see Figure 3). By the year 2000, coal consumption could reach 100 million tons annually, principally for industrial and thermal power generation (see Table 1). However, the share that coal will contribute to the total energy equations (estimated by Energy, Mines and Resources at 8.6 per cent) will be dependent upon the assumptions made concerning the availability of oil and gas, and the construction of additional hydro and nuclear capacity. A shortfall from any one of these sources could cause a significant increase in the demand for coal. For example, in an address to the 29th Canadian Conference on Coal, Mr. R.N. Sanders pointed out that curtailment of any new nuclear facilities by Ontario Hydro until after 1980 for environmental, financial or other concerns could increase Ontario's coal requirements by an additional 49 million tons or 2 1/3 times their current projected use with a planned nuclear program. A recent publication of the Canada West Foundation speculates a changing energy mix over the next 50 years (see Figure 4). You will note that the contribution of coal in 1990 is in excess of 10 per cent of the total energy demand. However, these are not intended to be firm forecasts but rather indications of the direction in which the energy picture may develop in the future. Regardless of the forecast chosen, it is obvious that coal will have a significant role to play in achieving Canada's goal of energy self sufficiency.

In order to determine whether coal may indeed satisfy the demands that will be placed upon it as an energy source, a review of our knowledge of the resource base is required. Before doing so, it is important to understand

FIGURE 2

Demand for energy by source: two scenarios

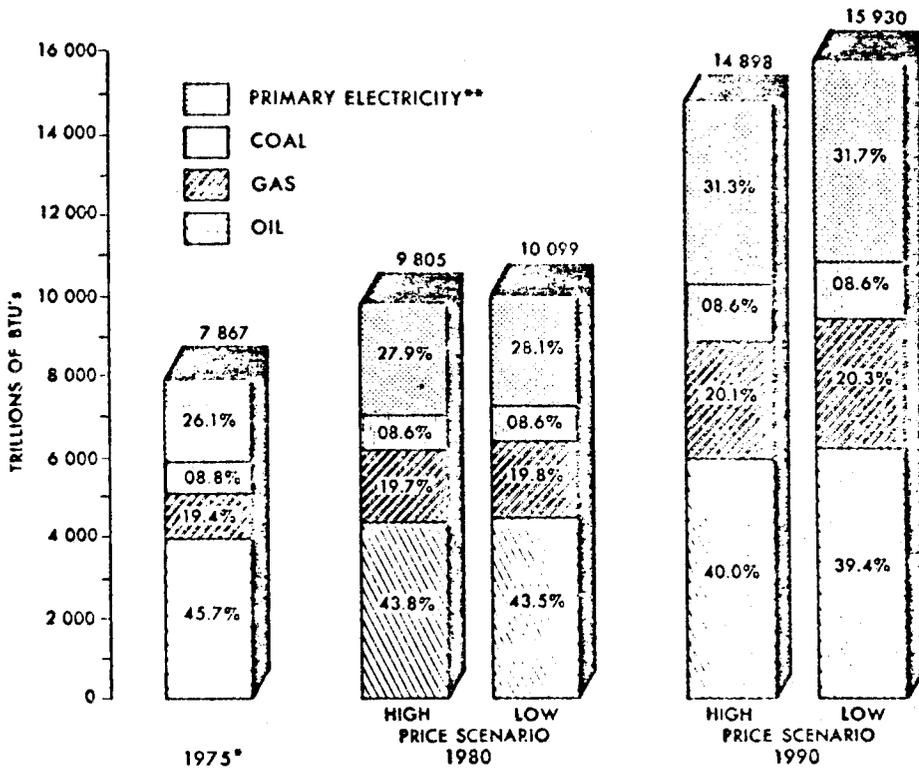

* Estimate.

** Primary electricity is hydro and nuclear valued at a fossil-fuel displacement value of 10,000 Btu/kilowatt-hour.

SOURCE: An Energy Strategy for Canada,
Energy, Mines and Resources Canada 1976

FIGURE 3

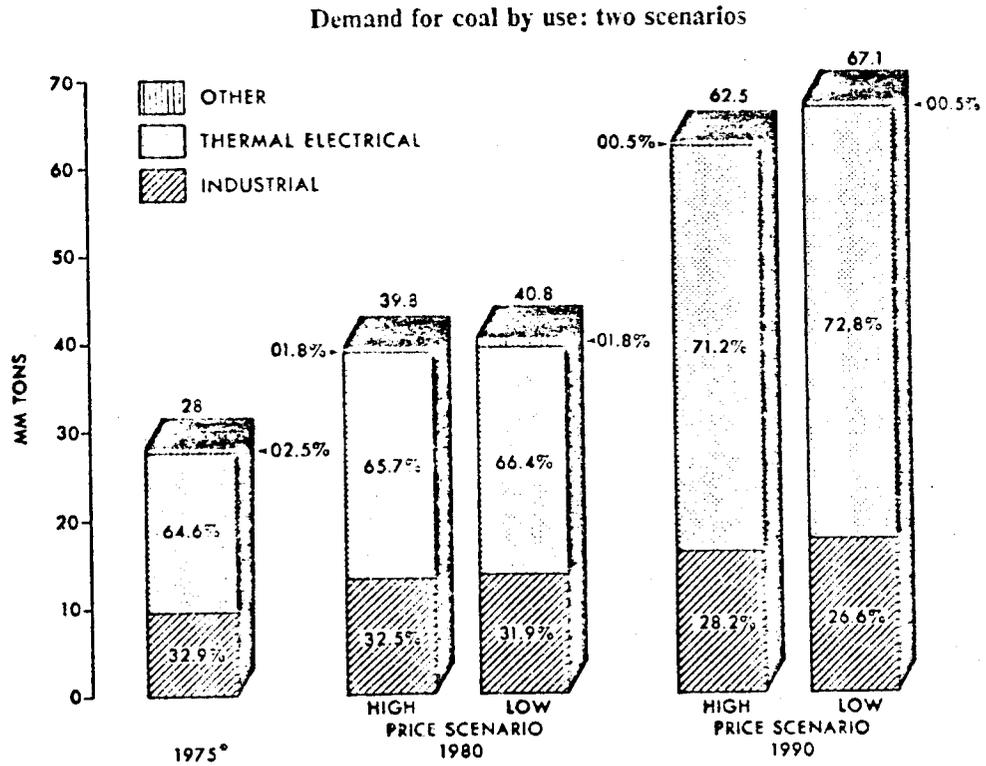

* Estimate

SOURCE: An Energy Strategy for Canada
Energy, Mines and Resources Canada,
1975

TABLE 1

CANADA

Coal Production, Imports, Exports and Consumption

1970 - 2000

(Millions of Metric Tons)

<u>YEAR</u>	<u>PRODUCTION</u>	<u>IMPORTS</u>	<u>EXPORTS</u>	<u>CONSUMPTION</u>
1970	13	17	4	26
1975	23	15	12	26
1985	35	25	15	45
2000	115	25	40	100

Source: Energy, Mines and Resources
Canada

FIGURE 4

THE CHANGING ENERGY MIX
A 50 YEAR SPECULATION
OF PERCENT USAGE
CANADA 1975 - 2025

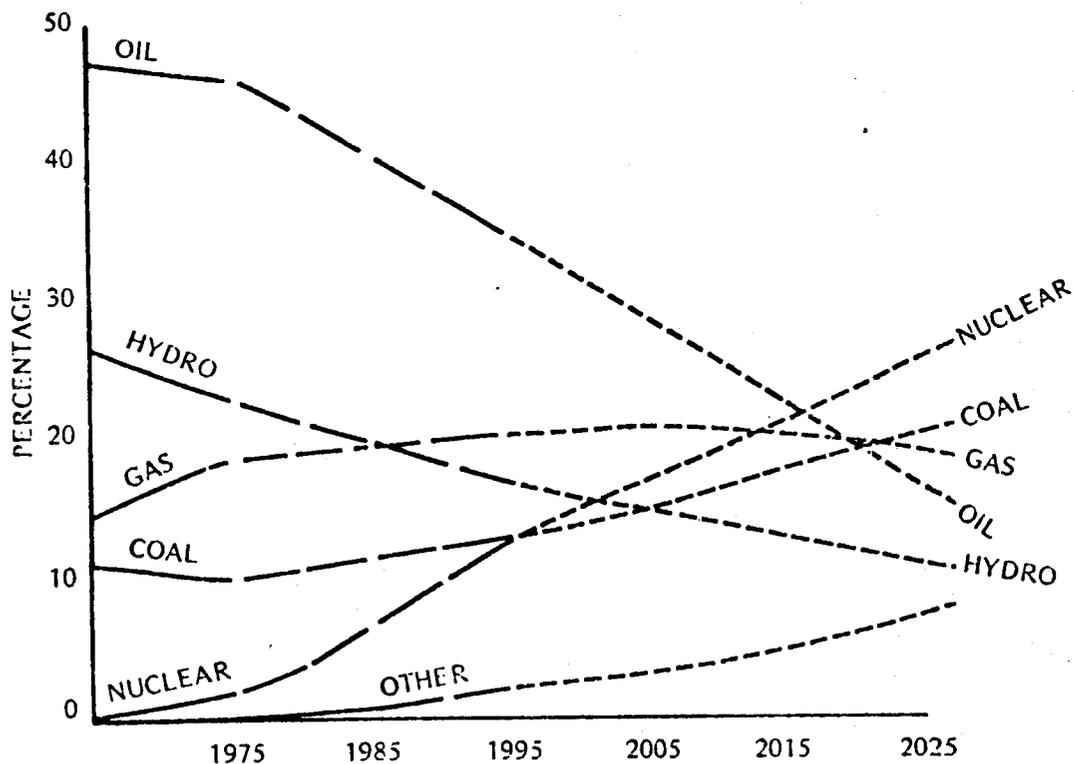

Source: Appendix D

SOURCE: Canada's Resources and the National Interest
Canada West Foundation, January 1977

the definitions used in describing the resource. The scheme adopted in British Columbia is essentially that proposed for Canada by the Department of Energy, Mines and Resources (see Figure 5). This classifies reserves according to degree of assurance of existence, and economic feasibility of production. Coal resources are natural concentrations of coal which occur in a form and place that make economic extraction feasible or feasible, within an arbitrary period of time (25 years in this schema). Coal reserves are those resources that have been accurately measured as to quality and tonnage, and are considered mineable under current economic and technological conditions.

Coal represents the largest resource of fossil energy in the world and is estimated at nearly 12×10^{12} tons, with a present resource to demand ratio of over 3500 years. Coal resources which are classified as in-situ reserves amount to about 1.9×10^{12} tons, which represents a reserve to demand ratio of 500 years. Economically recoverable reserves are estimated to be 0.5×10^{12} tons, which represents a reserve to demand ratio of 200 years.

Geographically, about 89.5 per cent of the world's coal resources are concentrated in the USSR, USA, and China; 8.8 per cent are located in Europe, Australia and Canada; Africa and India have 1.3 per cent, and the rest of the world has only 0.4 per cent. This distribution is shown in Figure 6.

Canada has approximately one per cent of the world's recoverable coal reserves and a reserve/demand ratio of about 500. The distribution of measured reserves and indicated resources of coal in Canada are outlined in Table 2. These two classes of resources have been combined in this table solely for purposes of comparison with Alberta and Saskatchewan, where the figures are available in this form only. The geographic locations of the coal fields in

FIGURE 5

VARIABLES: MONEY, RESOURCE BASE, TECHNICAL & GEOLOGICAL KNOWLEDGE

← INCREASING DEGREE OF GEOLOGICAL KNOWLEDGE

		RESERVES	RESOURCES		
		MEASURED	INDICATED	INFERRED	SPECULATIVE
INCREASING DEGREE OF ECONOMIC FEASIBILITY	ECONOMIC	GEOLOGICAL RAW CLEAN PROD- UCT RECOVER IN SITU			
	ECONOMIC WITH INCREASED DEMAND				
	UNECONOMIC				

VARIABLES: PRICE, MINING COSTS, TAXES

FIGURE 6

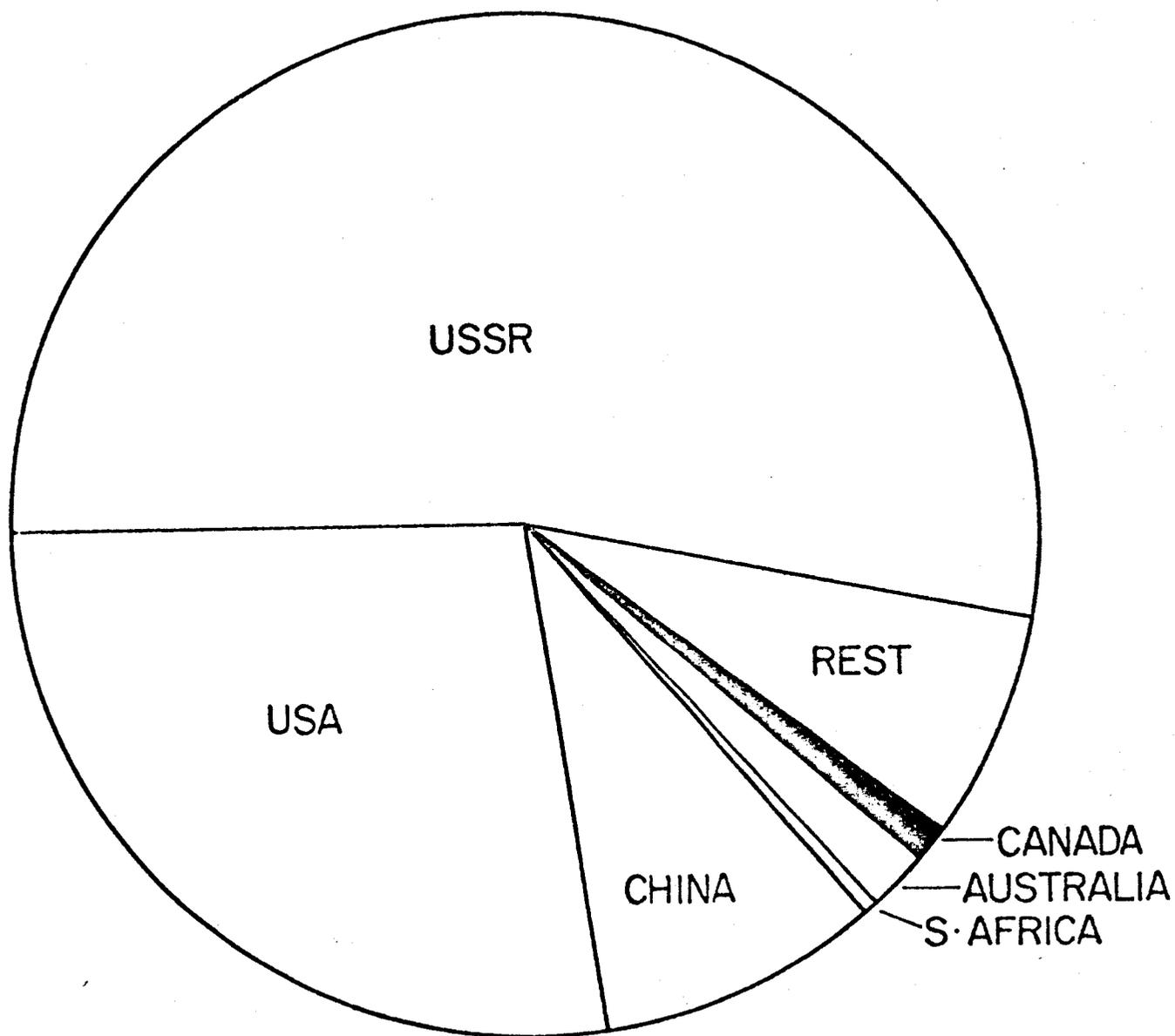

TABLE 2

COMBINED MEASURED RESERVES AND RESOURCES
OF CANADA
(BILLIONS OF SHORT TONS)

	Bituminous	Sub-bituminous
BRITISH COLUMBIA	9.8	1.925
ALBERTA	10.98	18.27
SASKATCHEWAN	-	5.7
ONTARIO	-	0.18
MARITIMES	0.4	-
	<hr/> 21.2	<hr/> 26.1

each province listed are illustrated in Figures 7, 8, 9 and 10.

I believe the resource base is capable of satisfying the foreseeable requirements for coal in our energy spectrum. However, there are a number of significant constraints to the realization of the role forecast for coal which can be resolved through a concerted effort by the public, by all levels of government, and by the coal industry and its related components. The areas that I feel are particularly significant are:

1. Transportation
2. Manpower recruitment and training
3. Environmental considerations
4. Capital investment
5. Mining technology
6. Technology of coal utilization
7. Government policies

The geographical location of coal deposits in Canada in relation to the major population and industrial centers has had a major inhibiting effect upon the development of a larger domestic coal market because of transportation logistics and costs. For example, in 1975, Canadian coal production was 23 million tons, and consumption was 26 million tons. However, 15 million tons of coal were imported and 12 million tons were exported. This resulted from the geographical relationship of producing and consuming areas of the country. Ontario, which essentially has no coal except for the lignite deposits of Onakawana, imports thermal and metallurgical coking coal for power

COAL PROPERTIES IN BRITISH COLUMBIA

PROPERTY	COMPANY
Sage Creek	Sage Creek Coal Ltd.
Corbin	Byron Creek Collieries Ltd.
Hosmer Wheeler	Kaiser Coal Canada Ltd.
Spanwood Ridge	Kaiser Resources Ltd.
Natal Ridge	Kaiser Resources Ltd.
Line Creek	Crowsnest Industries Ltd.
Fording River	Fording Coal Ltd.
Elk River	Elco Mining Ltd.
Quintette	Quintette Coal Ltd.
Bullmoose	Rometa Resources Ltd.
Sukwan	Condition Coal Ltd.
Cashan Creek	Oriskany Mines Ltd.
Mat Creek	B. C. Hydro and Power Authority

■ SURFICIAL EXPRESSION OF MAJOR COAL-BEARING FORMATIONS

- 1. N. P.
- 2. C. P.
- 3. P. P.
- 4. P. P.
- 5. P. P.
- 6. P. P.
- 7. P. P.
- 8. P. P.
- 9. P. P.
- 10. P. P.
- 11. P. P.
- 12. P. P.
- 13. P. P.
- 14. P. P.
- 15. P. P.
- 16. P. P.
- 17. P. P.
- 18. P. P.
- 19. P. P.
- 20. P. P.
- 21. P. P.
- 22. P. P.
- 23. P. P.
- 24. P. P.
- 25. P. P.
- 26. P. P.
- 27. P. P.
- 28. P. P.
- 29. P. P.
- 30. P. P.
- 31. P. P.
- 32. P. P.
- 33. P. P.
- 34. P. P.
- 35. P. P.
- 36. P. P.
- 37. P. P.
- 38. P. P.
- 39. P. P.
- 40. P. P.
- 41. P. P.
- 42. P. P.
- 43. P. P.
- 44. P. P.
- 45. P. P.
- 46. P. P.
- 47. P. P.
- 48. P. P.
- 49. P. P.
- 50. P. P.
- 51. P. P.
- 52. P. P.
- 53. P. P.
- 54. P. P.
- 55. P. P.
- 56. P. P.
- 57. P. P.
- 58. P. P.
- 59. P. P.
- 60. P. P.
- 61. P. P.
- 62. P. P.
- 63. P. P.
- 64. P. P.
- 65. P. P.
- 66. P. P.
- 67. P. P.
- 68. P. P.
- 69. P. P.
- 70. P. P.
- 71. P. P.
- 72. P. P.
- 73. P. P.
- 74. P. P.
- 75. P. P.
- 76. P. P.
- 77. P. P.
- 78. P. P.
- 79. P. P.
- 80. P. P.
- 81. P. P.
- 82. P. P.
- 83. P. P.
- 84. P. P.
- 85. P. P.
- 86. P. P.
- 87. P. P.
- 88. P. P.
- 89. P. P.
- 90. P. P.
- 91. P. P.
- 92. P. P.
- 93. P. P.
- 94. P. P.
- 95. P. P.
- 96. P. P.
- 97. P. P.
- 98. P. P.
- 99. P. P.
- 100. P. P.

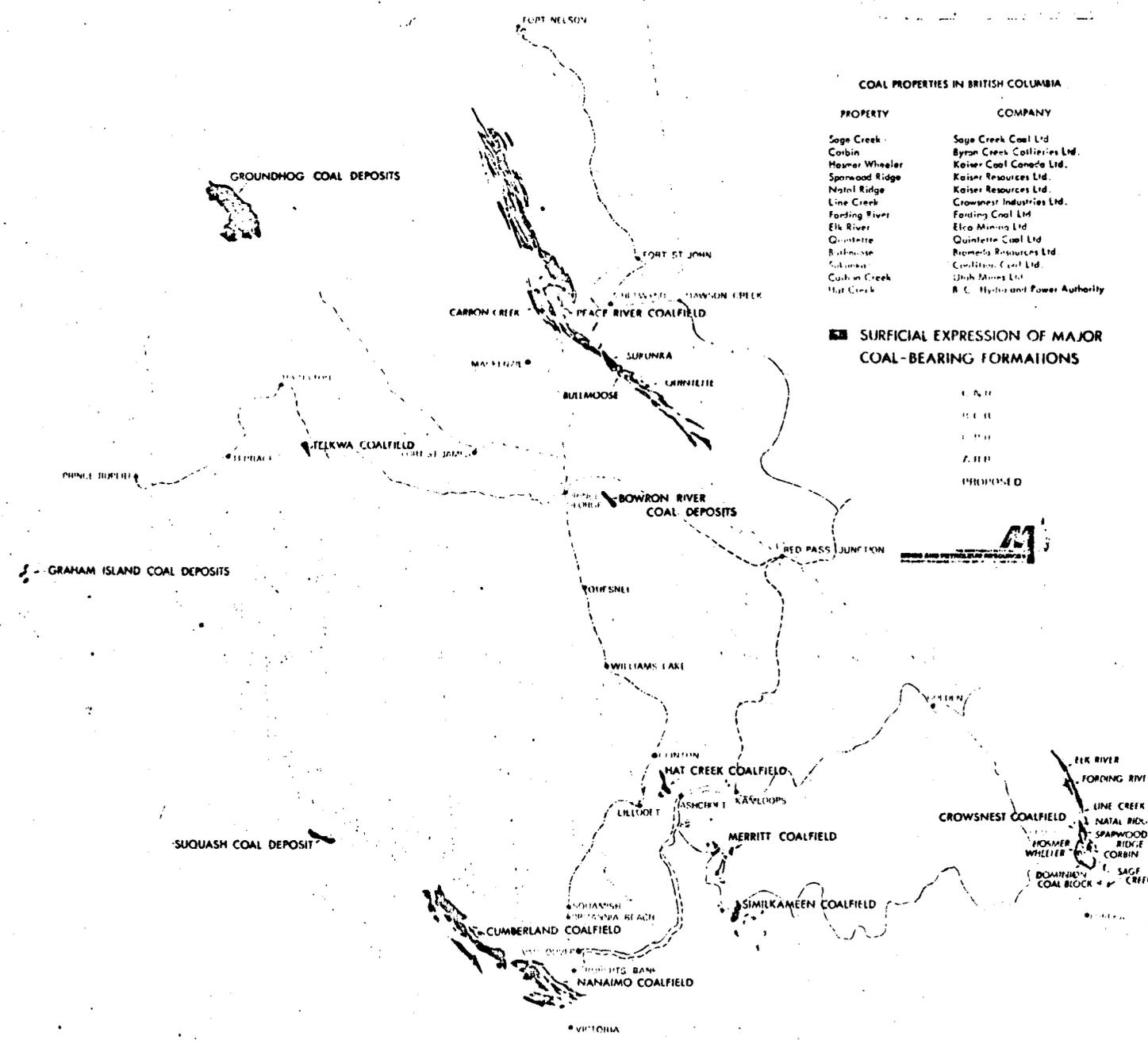
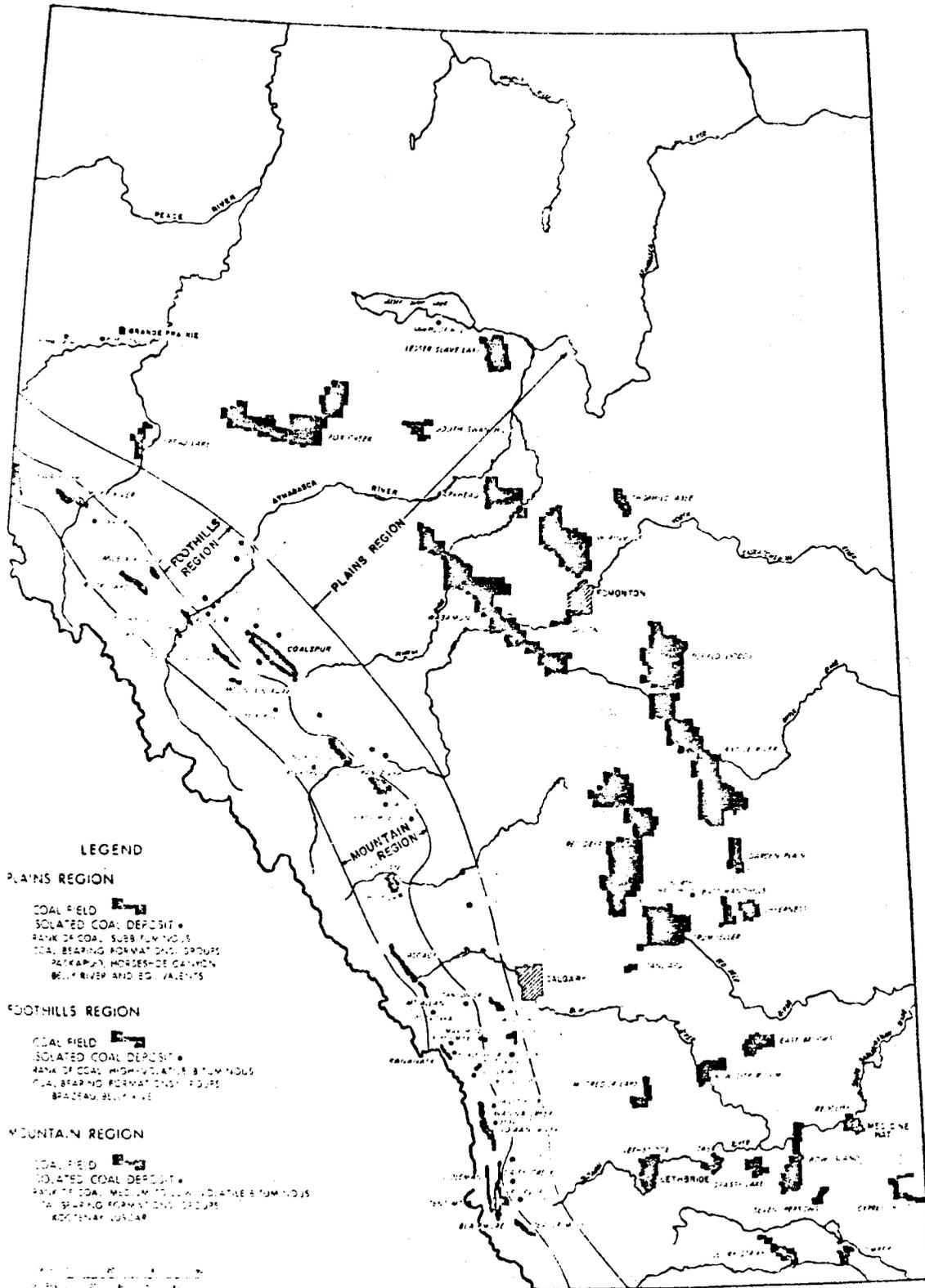

Figure 7

FIGURE 8



THE COAL REGIONS, DESIGNATED COAL FIELDS, AND ISOLATED COAL DEPOSITS IN ALBERTA

FIGURE 9

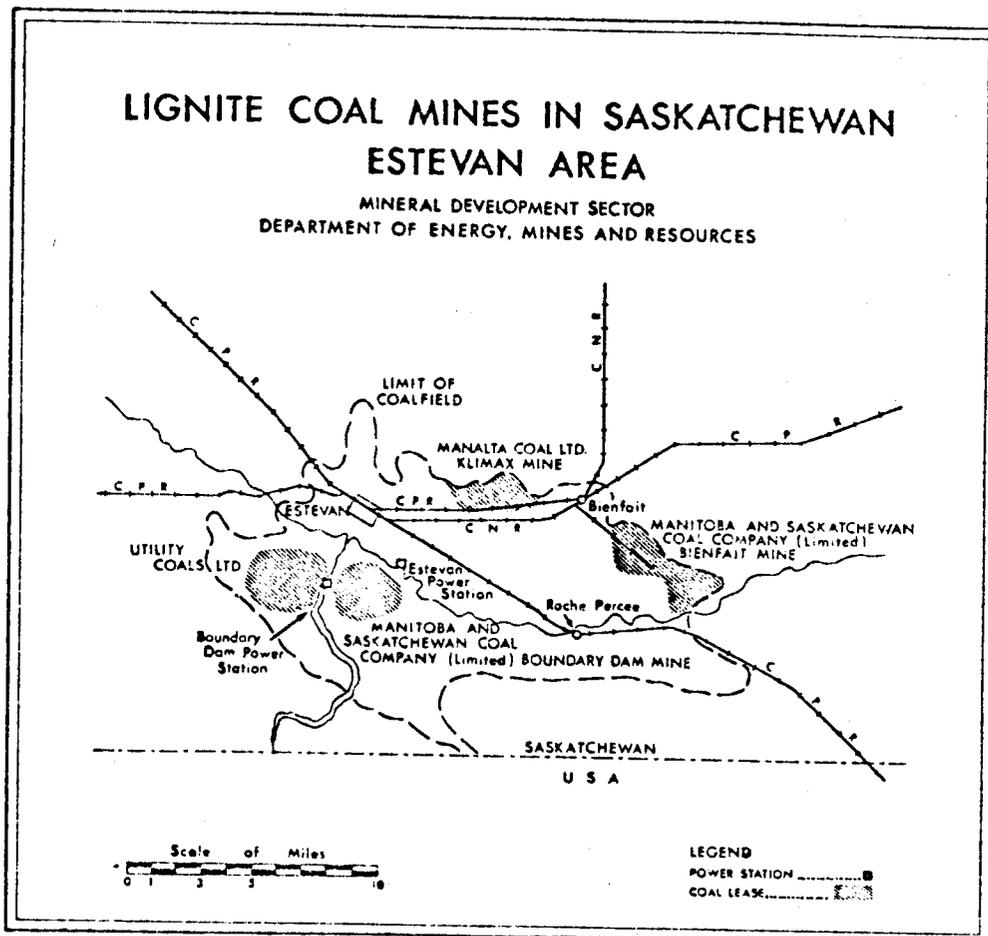

Figure 10

LEGEND

-  Productive coalfields, land areas
-  Submarine extensions of coalfields



N.B.

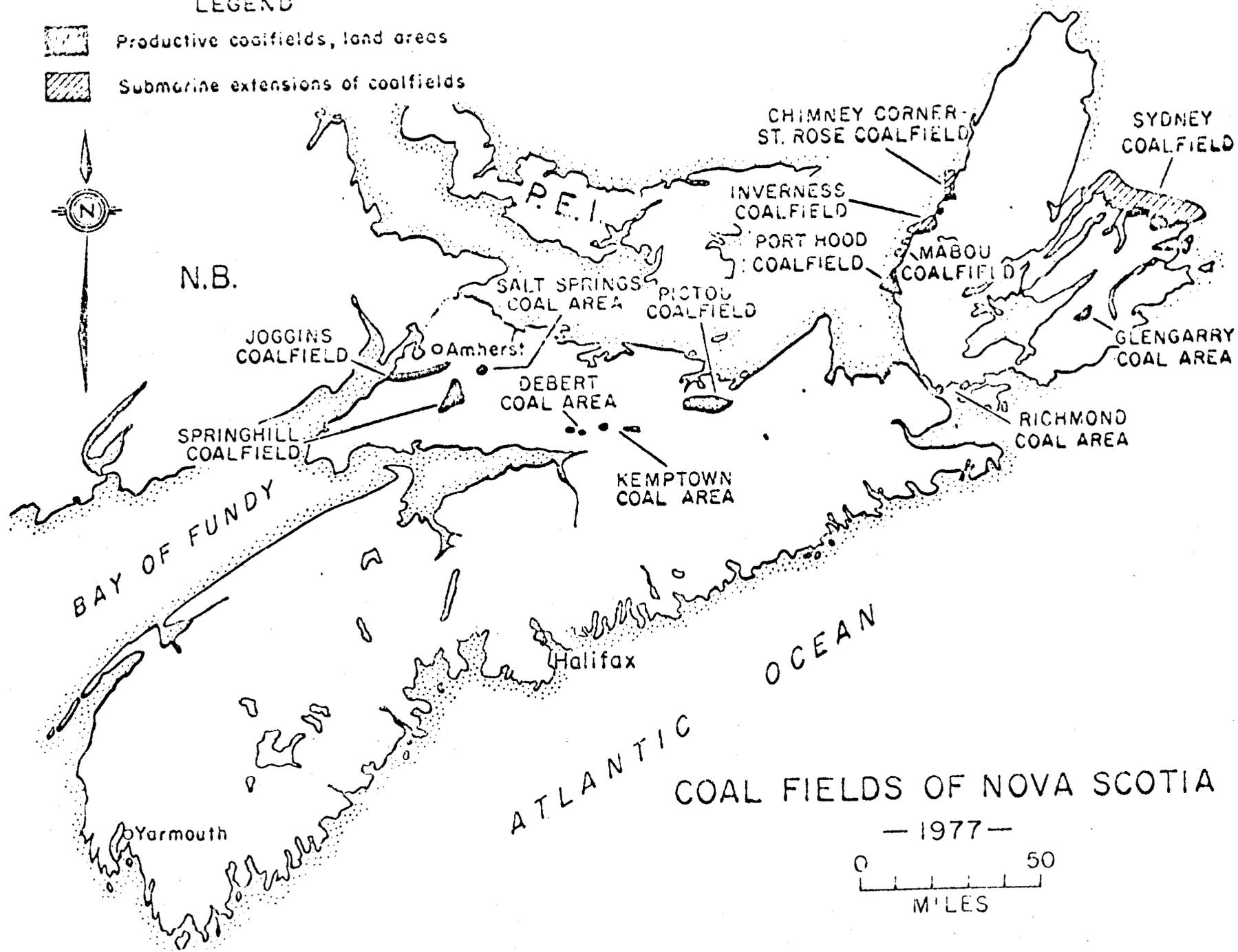

1881

ATLANTIC OCEAN

COAL FIELDS OF NOVA SCOTIA

— 1977 —



generation and steelmaking from the United States, principally from nearby Pennsylvania and West Virginia. Reasons for the development of such marketing relationships are obvious. Similarly, over 90 per cent of Canada's exports were of metallurgical coking coal from Alberta and British Columbia, destined for Japan and other Pacific Rim countries.

With the advent of the energy "crisis", coal prices in the USA, as in other parts of the world, have risen dramatically. In addition, energy shortages and environmental pressures on thermal power utilities for lower sulphur emissions in the United States have raised concerns in Canada regarding the potential scarcity of supplies of US coal and the availability of increasing supplies. Ontario Hydro, which currently uses about 7.5 million tons of US coal, expects to import up to 12 million tons by 1985. However, increasing production of western Canadian coal is forecast, and could reach 5 - 6 million tons by that year. Movement of western Canadian coals to eastern markets has now become feasible, and railroad upgrading plus development of port facilities at Thunder Bay have been necessary. Much of the experience in transporting coal by unit train from Alberta and eastern British Columbia to Vancouver for export has been invaluable in permitting efficient systems for eastern movement to be developed (see Table 3). Technological improvements in rail and port facilities will continue to be required to assure reliable, efficient and economical coal transportation. In addition, equitable determination of freight rates between shippers and railroads are required to permit western coals to be a viable alternative to other energy sources. Initial reaction by coal shippers to Bill C-33, which proposed amendments to the various Canadian transportation acts, was not favourable. It is hoped that final

TABLE 3

ESTIMATED RAILWAY INVESTMENT TO 1990*

(\$ MILLION)

1. BCR	
(a) Mine Access lines	38
(b) Mainline upgrading (Chetwynd-N. Vancouver)	81
2. CNR	
(a) Mainline upgrading-west bound (Prince George-Prince Rupert)	32
(b) Mainline upgrading-eastbound (Prince George-Red Pass)	22
(c) Mainline-eastbound (Red Pass-Thunder Bay)	1,000-2,000
3. CPR	
(a) Mainline-westbound (selected east-slope doubling)	70
(b) Mainline-eastbound (Golden-Thunder Bay)	220-400
4. Additions to Network	
(a) Clinton-Ashcroft (BCR-CNR/CPR link)	40
(b) CPR-Kootenay and Elk (connection to Burlington Northern)	16

*These costs do not include complementary yard and siding augmentation or the replacement of rolling stock and existing plant. This could double items 2(c) and 3(b).

SOURCE: Coal in British Columbia: A Technical Appraisal
Coal Task Force, 1976.

amendments will provide a satisfactory basis for rate determination.

Development of new coal mines, as well as tar sands treatment facilities, gas pipelines and other energy-related resource projects may create an acute demand for construction labour and investment capital. Thus a coordinated scheduling of major projects would be desirable. In 1974, the Economic Council of Canada made the following recommendation in its report entitled, "Toward More Stable Growth in Construction":

We recommend that simultaneous peaking of major construction projects be avoided as far as possible. The responsibility of preventing simultaneous peaking should lie mainly with the Federal Cabinet, which should undertake a periodic review of the schedules, and the prospective impact of the economy, of all forthcoming major projects in order to decide whether some rescheduling would be both feasible and desirable. In all cases, there should be advance discussion and periodic review with any Provincial Government concerned.

The recruitment and training of a skilled labour force for coal mining, particularly underground, will require a concerted effort by industry, government and educational institutions. Many of the skills associated with coal mining were lost in Canada during the period from 1945 to the late 1960's. Training facilities and programs will be required to permit a maximum number of Canadians to enter the industry, and to minimize problems associated with the recruiting of a skilled workforce through immigration. The recent report of the B.C. Coal Task Force (1976) estimated that a sevenfold increase in mine employment (from 1850 to 13,000 direct employees) could be anticipated by the end of the century in British Columbia coal mines. Although productivity per man shift is greater in open pit mines, a significant increase in employment may also be anticipated in the foothills and plains regions.

Development of coal mines in Canada, both open-pit and underground, result in disturbance of the surface and may have significant impacts on the existing environment, communities, transportation infrastructure and regional economy. Responsibility for establishing standards for coal mine development resides with the Provinces, and each has developed to a greater or lesser extent, a procedure of assessing, evaluating and managing such impacts during the planning and development stages of each project. The procedure used by British Columbia is outlined in Figure 11. A review process is conducted at the end of each stage of the project by the Coal Guidelines Steering Committee, which consists of personnel from the Ministry of Mines and Petroleum Resources, the Ministry of Environment, and the Ministry of Economic Development. The procedure covers the major economic, social and environmental implications of coal development and seeks a balance between these three factors. Where public funds are required for transportation or community infrastructure, and where significant environmental or social costs are involved, benefit/cost analyses are conducted to determine the appropriate course of action prior to granting of approvals. The process is based upon integrated resource planning, and requires a responsible and cooperative approach by Government, industry and the public at large in order that maximum benefit to the Province and the industry is obtained. Realistic environmental goals must be established, and met, in order that Canada's energy goals can be achieved in an acceptable manner.

Capital investment for an underground or open pit coal mine is high, as shown in Table 4. Although this applies to a metallurgical coking coal mine, it will be similar to the costs associated with thermal coal developments.

COAL DEVELOPMENT ASSESSMENT PROCEDURE

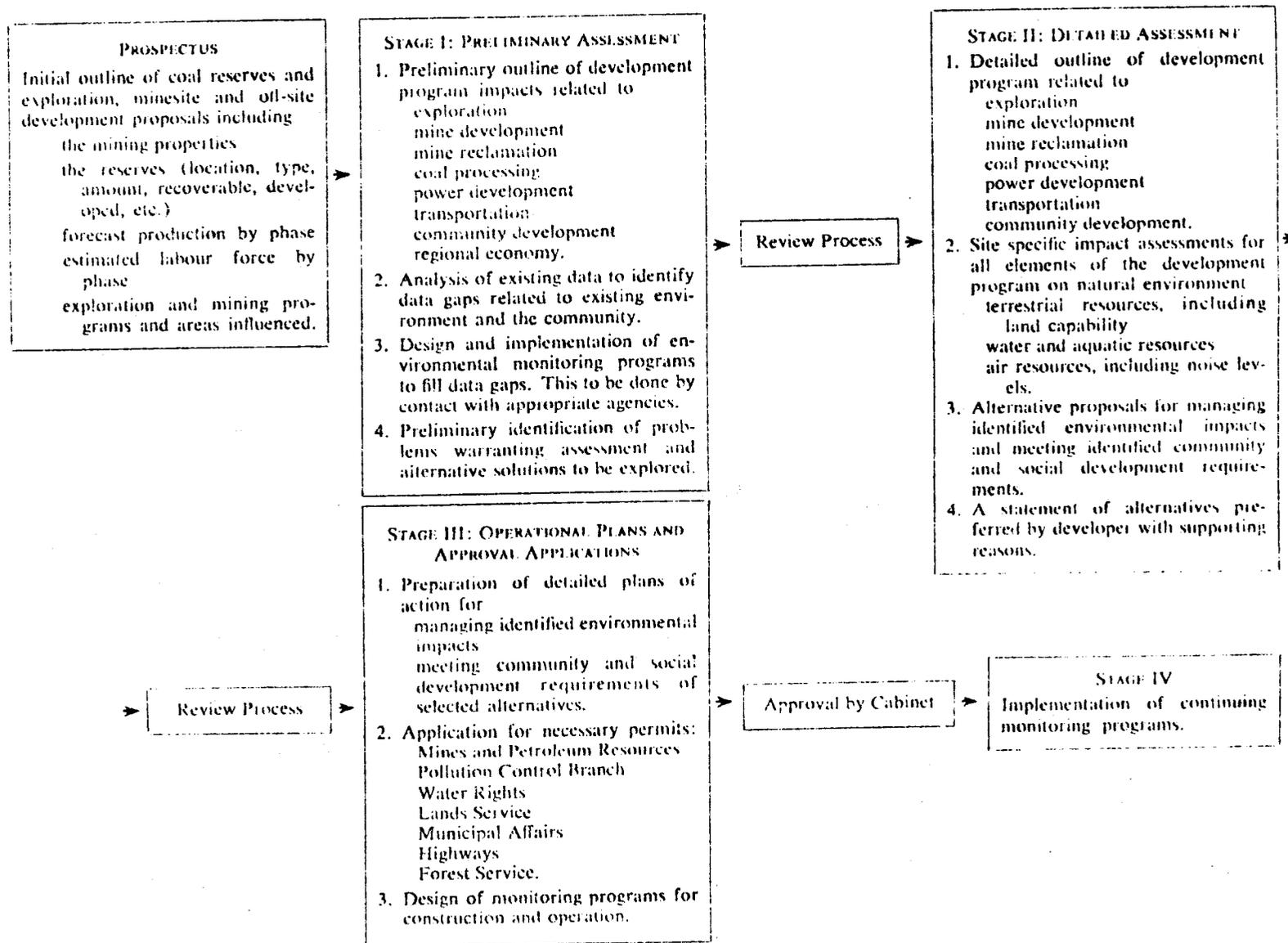

TABLE 4

TYPICAL CAPITAL COSTS TO PLACE NEW COAL MINE IN PRODUCTION

1975 \$Million/Million Tpy Clean Coal Production, Assuming 70% Recovery
From Raw Coal Mined and 3 Million Tpy of Clean Coal Production

A. Mining and preparation-	Cost (\$Million/Million Tpy)
Open-pit mine (including shovels, trucks, etc.) -----	15
or	
Underground mine (equipment and facilities) -----	20
Preparation and handling facilities -----	20
Ancillary buildings -----	5
Preproduction expenses-	
Open pit -----	5
or	
Underground -----	15
Cost range -----	<u>45-60</u>
B. Transportation-	
Unit trains -----	10-15
Spur lines -----	10-25
Port Facilities -----	10
Cost range -----	<u>30-50</u>
C. Infrastructure-	
Townsite -----	15-25
Access roads -----	5
Power supply -----	5
Cost range -----	<u>25-35</u>
D. Total-	
Cost range -----	100-145

It is not possible to generalize about economies of scale with larger mines, but the minimum size will usually be set by the throughput required to amortize infrastructure investment, and this will vary depending on the mine location.

Total cumulative investment over the period 1975 to 1995 is likely to be of the order of not less than \$3 billion.

As is shown, cost of production facilities is only one component of capital requirements. Transportation improvements and infrastructure development can more than double the investments in mining and preparation facilities, and thus proposed developments must be examined in terms of total costs.

In the present climate of inflation and heavy demands on world capital markets by governments and institutions, particularly for energy projects, there is increasing concern about the ability to raise funds for new projects. The trend in financing new coal projects is for the majority of the required funds to be supplied by the users of the coal. In the case of coal for thermal use, financing is already directly or indirectly undertaken by the utilities involved. Similarly, new metallurgical coking coal projects normally include financial involvement by the end user. Nevertheless, heavy investments are required to meet Canada's energy goals and the coordinated scheduling of major projects, mentioned previously, would be desirable. In an address to the Calgary Chamber of Commerce in October 1977, John A. Dawson, Executive Director, Canadian Energy Research Institute suggested that the total energy investment could rise to 5.2 per cent and perhaps as high as 5.6 per cent of GNP, probably reaching a peak over the period 1981 - 85 of at least 6.5 per cent as compared with 4.0 per cent of GNP during the previous peak period of energy investment from 1956 - 60. His review indicated that, after allowing for energy investment, roughly 19 per cent of GNP would be available for investment in other sectors of the economy as compared with an average of 20.4 per cent in the last 20 years. It was indicated that this adjustment was reasonable if one considers the reduction in social capital required for education, public health and residential construction that could take place

resulting from a lower rate of population growth than in the immediate post-war period.

Maximization of the recovery of the coal resource, particularly from underground mines, will require first the application and development of advanced mining technologies such as hydraulic mining. Previous experience with the difficult mining conditions encountered in the Rocky Mountain region indicates that major efforts will have to be made to obtain detailed knowledge of the geology of the coal deposits and to develop techniques for the early detection of roof instabilities and roof control. For surface mines, pit design, pit slope stability and waste disposal are significant problems which must be dealt with in order to maximize resource recovery. For example, the geological setting of the Hat Creek deposit will require relatively shallow pit slope angles which will limit pit depth and thus economic coal recovery by conventional surface mining methods. More complete recovery of coal from this location, as well as for the deeper plains coals, may require underground mining methods or in situ gasification techniques.

The second factor in maximizing recovery of the resource is concerned with beneficiation of the raw coal to a marketable product. Much of the mountain bituminous coals appear to beneficiate relatively easily, but the varying characteristics of coal deposits will require innovative designs for treatment plants to maximize economic recovery levels. Resource conservation also requires research and development programs to find economic processes for the use of reject materials, particularly those produced in the beneficiation of bituminous coals for the coking coal market.

Coal can be a direct or indirect source of energy, a direct or indirect

source of hydrogen, a source of carbon and a direct or indirect source of chemical compounds (see Figure 12). For the present, since non-fossil fuel sources of energy are still in the development and early exploitation stage, it is evident that fossil fuels, and particularly coal, will continue to be used as a source of heat and electricity. Also the blast furnace is projected to remain the dominant technique for making large tonnages of iron well into the next century and therefore coke-making will continue to generate a large demand for coal. However, in the long term the role of the so-called fossil fuels as an irreplaceable source of carbon for chemicals will come to be of primary importance. A recent study by Shell has indicated that the growth rate of the petrochemicals industry must halve by the end of the century because continuation at the recent growth rate would lead to all of the available fossil hydrocarbon production being used for petrochemicals manufacture by about the year 2020. This may be an overly pessimistic view in the light of our current knowledge and the reduced rate of growth in energy demand.

The major problems in coal utilization are associated with handling, because it is a solid; waste disposal, because it is not purely organic; pollution, because noxious gases and fine particulates are generated during its breakdown; and its variable chemical and physical properties, which arise from differing geologic factors in its formation. These problems profoundly influence the technology of the two present principal uses of coal, electricity production and carbonization, and a future potential use -- gasification for Syngas production.

The method of burning coal in existing large thermal generating stations

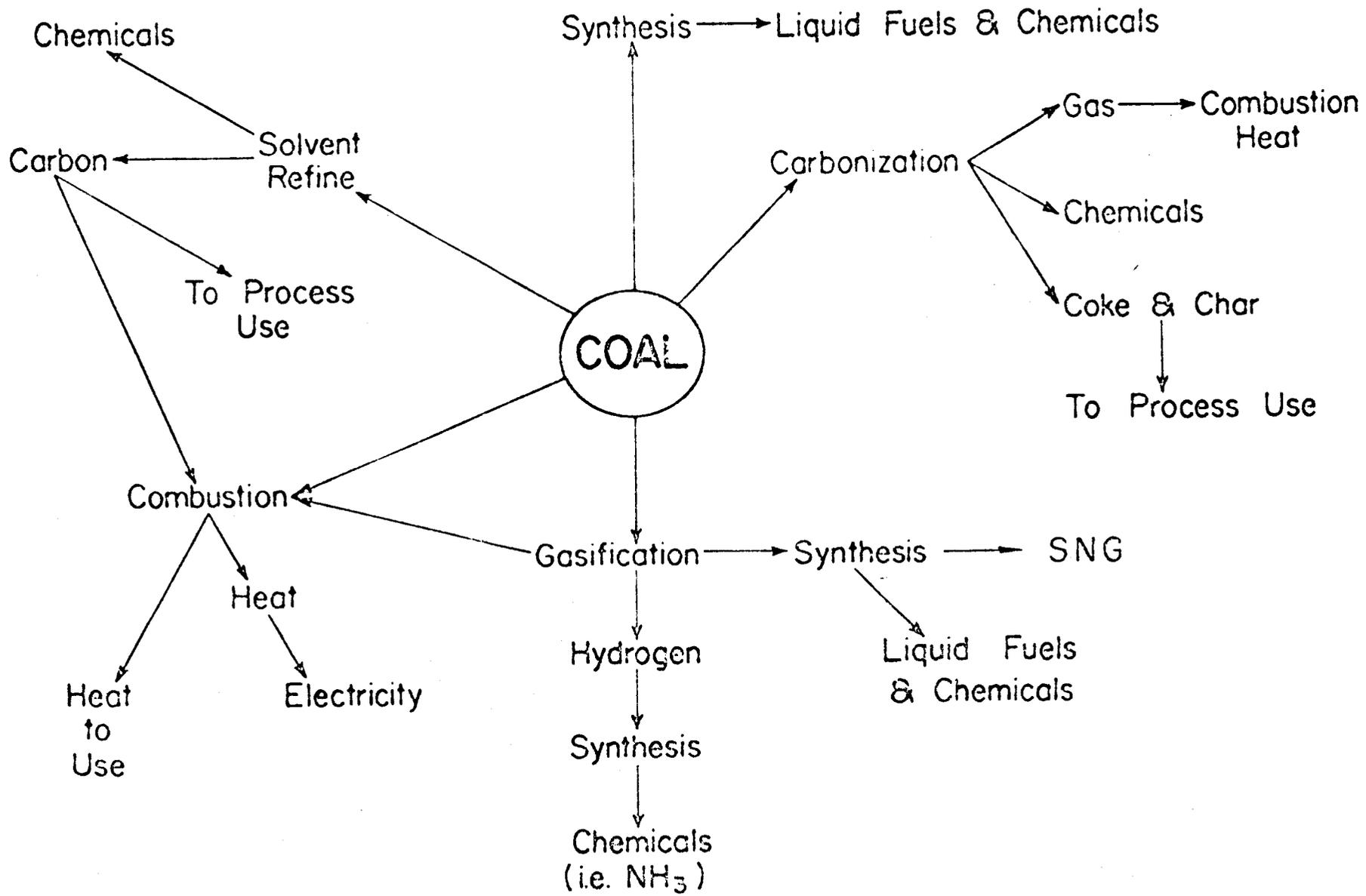

is by suspension firing. This method permits the use of a wide variety of coals but does have some problems with respect to combustion products such as fly ash, sulphur dioxide and oxides of nitrogen. The first may be effectively reduced by electrostatic precipitation and the second by gas scrubbing equipment, although the latter process is very costly and has not been fully satisfactory to date. Oxides of nitrogen can be controlled only by furnace design which reduces flame temperature, excess air and residence time.

New combustion techniques are currently under development. They are designed to use lower grade fuels while at the same time meeting more stringent pollution control standards. The techniques which show the most potential in this regard and which also offer the promise of higher efficiency employ fluidized combustion or gasification followed by combustion. Fluidized bed combustion appears to offer advantages in reducing the size and cost of boiler units, as well as much lower particulate and gaseous pollutants. Research programs are under way in a number of countries but the process is still untried for power generation on a larger scale. The principle of a coal-fuelled power plant employing a gas/steam turbine combined cycle based on the gasification of coal is under development in the U.K., United States and West Germany. Commercial-sized plants are not expected to be operational until the late 1980's. Overall energy conversion efficiencies of 40 per cent are anticipated with SO_2 , NO_x and particulate emissions well below that achieved for conventional plants. Figure 13 outlines a scheme utilizing fluidized bed combustion and coal gasification for combined power generation and industrial heating.

Figure 13

COAL UTILIZATION TRI-GENERATION

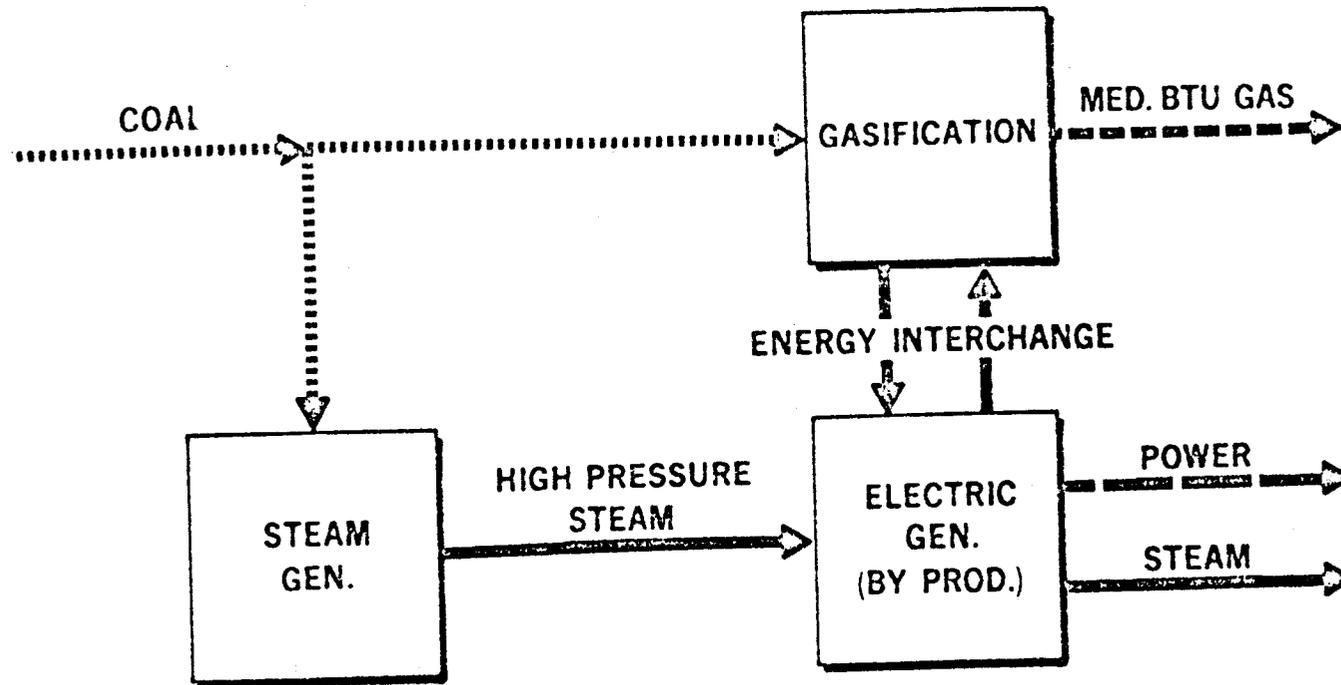

Gasification of coal to produce a synthesis gas as the raw material for combustion, substitute natural gas production, and petrochemical manufacture has been conducted in a number of countries, most notably in West Germany and South Africa. Gasification of coal as a separate process essentially involves the controlled addition of oxygen and hydrogen using steam and air or pure oxygen as reagents. The Lurgi process is a well known example of this technology (see Figure 14). Synthesis gas, a mixture of carbon monoxide and hydrogen, may be used as feed stock for production of ammonia, methanol and liquid hydrocarbons, or may be converted by a methanation step to SNG. To date, such processes have only been economically attractive where indigenous sources of petroleum or natural gas do not exist. Gasification for the manufacture of these products will assume greater importance as the supply of conventional hydrocarbons diminishes and their prices escalate.

While gasification has attracted the major share of research and development interest in North America in recent years, the production of liquids from coal must also be considered. With the possibility of quickly augmenting dwindling natural gas supplies, gasification is immediately attractive; but in the long term liquefaction may be of greater interest (see Figure 15).

There are four broad routes to liquids productions from coal, including pyrolysis (see Figure 16). The catalytic hydrogenation route, known in its early form as the Bergius process, was used extensively, along with the synthesis gas route employing Fischer-Tropsch synthesis, to produce gasoline in Germany during World War II. The former process was used for about 85 per cent of the German production and from the conversion standpoint remains

LURGI GASIFICATION

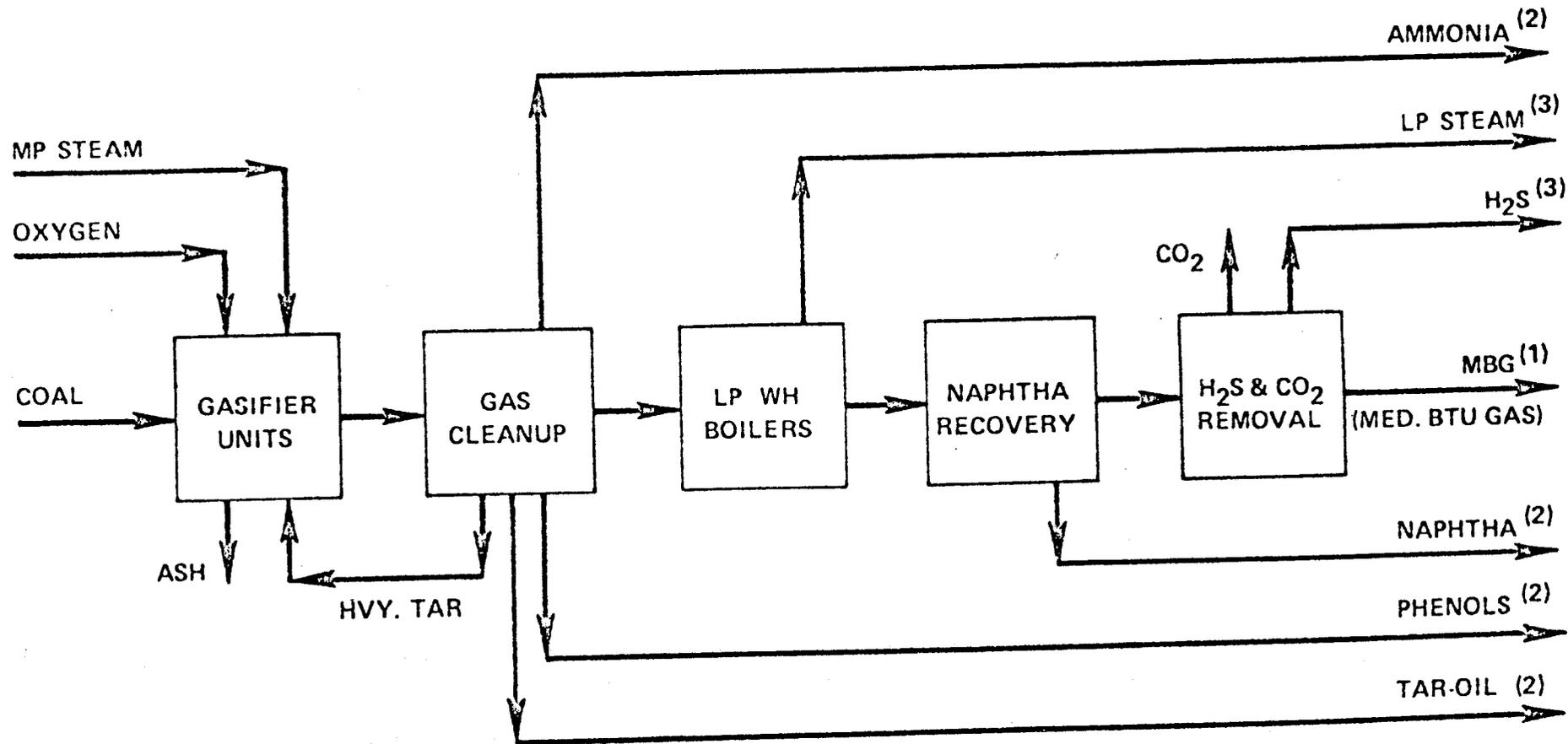

- (1) PRIMARY SEND-OUT PRODUCT
- (2) SEND-OUT BYPRODUCTS
- (3) PLANT SITE INTEGRAL USE

FIGURE 15

SNG PROCESS AND ALTERNATIVES

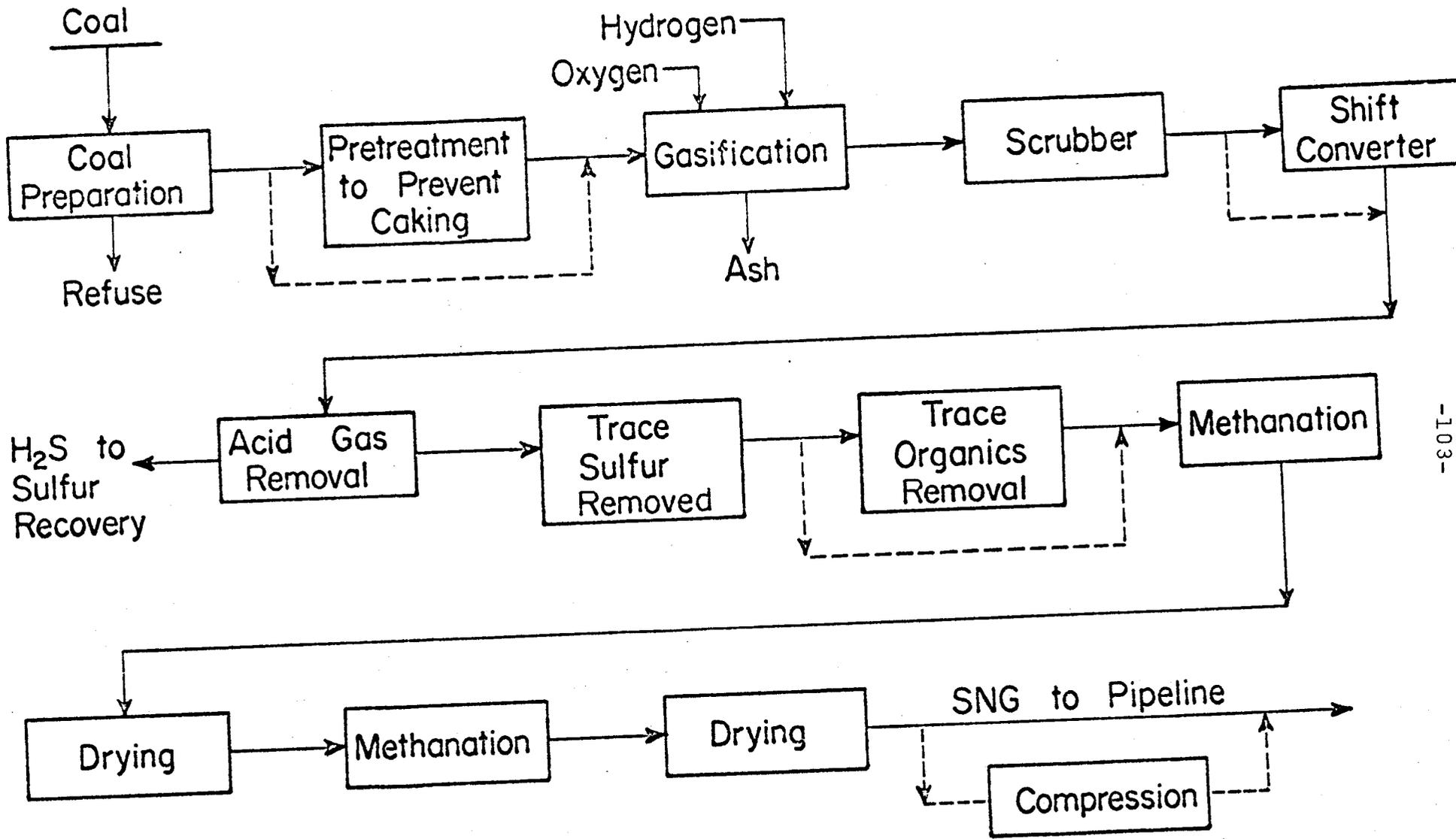
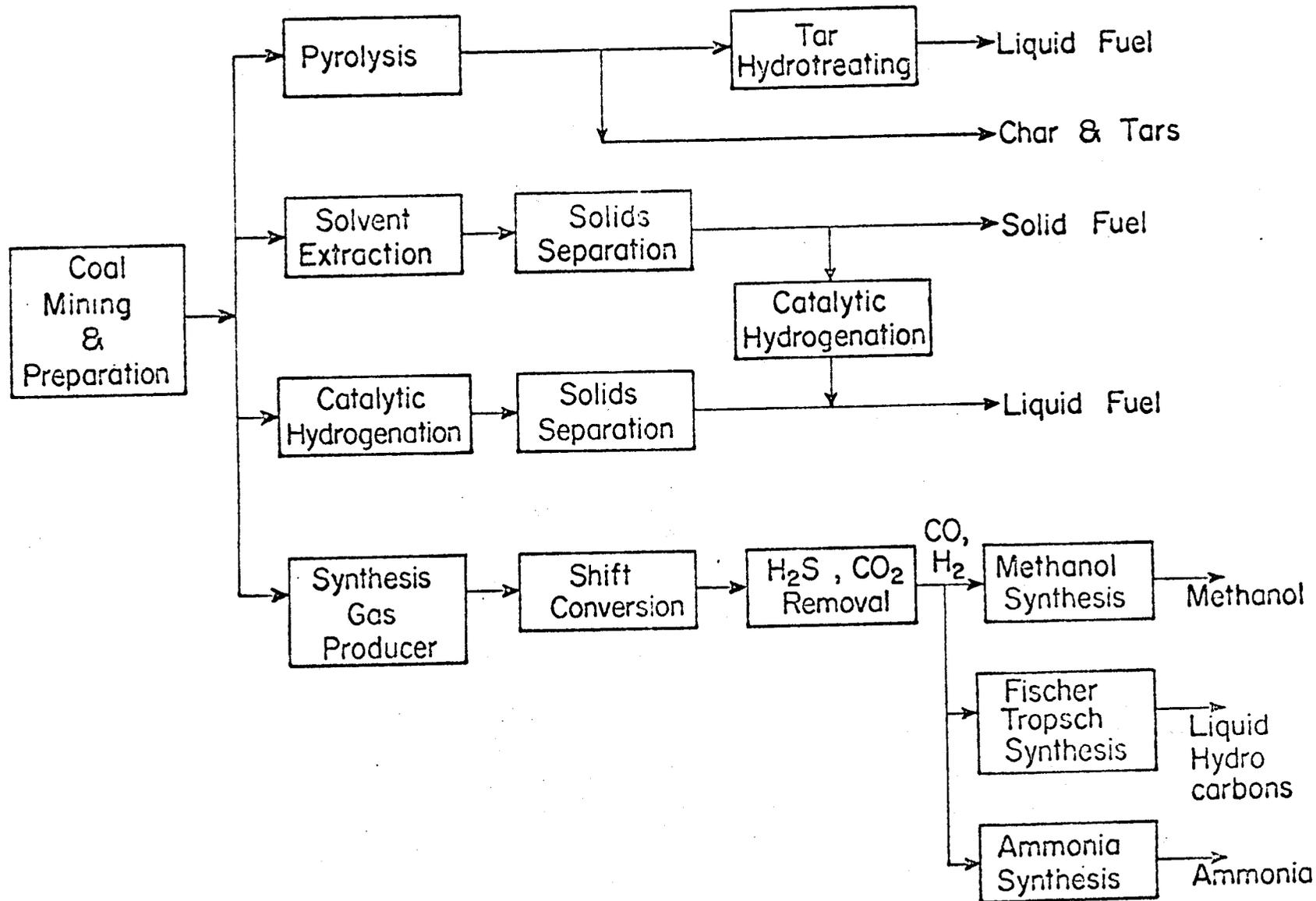

FIGURE 16

LIQUEFACTION ROUTES



preferable; the gas route gives an over-all conversion efficiency of only 38 per cent. Despite this objection, the gas route is a proven alternative, as the South Africans have demonstrated at their Sasol plant, which uses some 5 million tons of coal per year.

The major technical difficulty with the Bergius and solvent extraction process for coal treatment is in the separation of the inorganic residue from the liquid organic products. It appears certain that this problem will be solved, although it is unlikely that any major coal liquefaction facility could be considered for construction inside 10 years.

Alternatives to conventional coke-making techniques involve the manufacture of a product by carbonization of coal briquettes which have been shaped mechanically and heated beyond the decomposition temperature of the coal during the process. A typical sequence is shown in Figure 17. The resulting product, formcoke, has advantages over conventional blast furnace coke in that relatively cheap, indigenous, low-rank, non-coking coals can be used to make an acceptable blast furnace material. This technology will become increasingly important in the next decade.

A major determinant in meeting Canada's energy goals will be the climate that all levels of government create to foster the effective development of the coal industry. Alberta and British Columbia have announced coal policies, and Saskatchewan is expected to do so in 1978. In addition, the Federal Government is anticipated to further formulate and articulate policies concerning the role of the coal resource in the energy picture. A determined effort will be required to cooperatively develop such policies to minimize the constraints indicated previously and to equitably resolve current

FIGURE 17

THE FMC PROCESS FOR FORMCOKE PRODUCTION

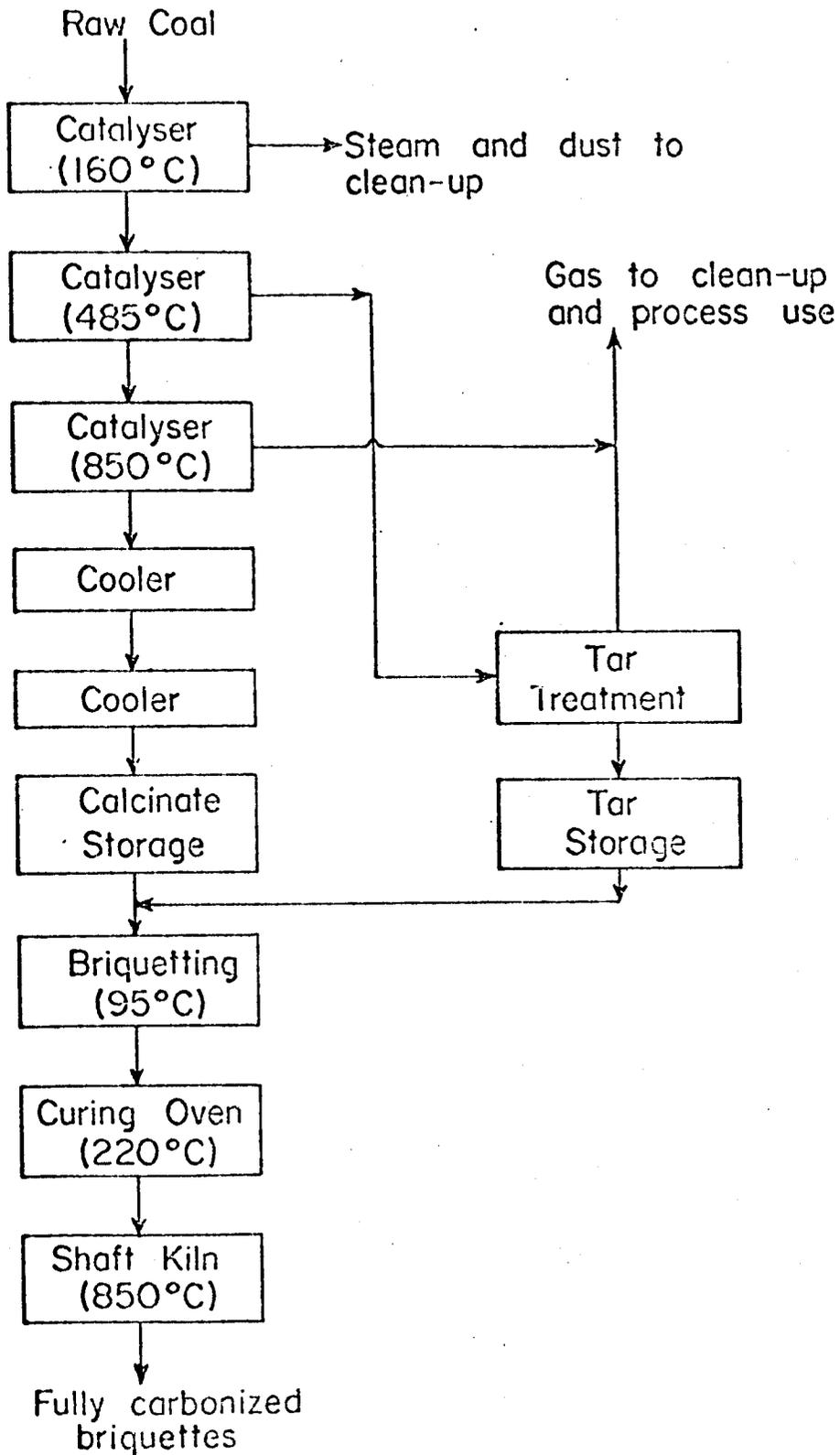

differences concerning resource industries.

Finally, a major effort is required to wisely conserve the energy resources available to all Canadians. It has been indicated by the Canada West Foundation that even a decrease of one tenth of one percent in the annual growth of our energy consumption would result, by 1990, in savings equivalent to the output of an entire oil sands plant with a cost in excess of \$2 billion.

CANADA'S ENERGY STRATEGY

G. M. MacNabb
Deputy Minister
Energy, Mines and Resources

It is a pleasure to join with you today in what hopefully will be an informal seminar on Canada's Energy Policy.

We are all concerned with Canada's future energy situation. Of course we cannot define precisely the national prospects 10, 15, 20 years hence - much will depend on the decisions we take this year. We can, however, establish a range of possibilities. This is in fact an essential base for policy planning. The basic energy planning document for the federal government is An Energy Strategy for Canada - Policies for Self-Reliance.

First of all, let's get rid of one misconception. There is no simple means of providing a secure energy future for Canada. Many people continue to place their faith in a new and novel cure-all arriving to not only solve supply, but also price problems. They, in effect, wish away the very real nature of the challenges we face and the changing conditions we must adapt to. But there is no cure-all in sight. New technologies will not meet our pre-1990 requirements although they will make a contribution. We must close the lion's share of the energy gap by much more aggressive action on our energy conservation efforts, and we must develop the resource base which is available to us. The latter is where a crisis of choice comes in. How much should we invest in expensive oil sands resources? How much in coal, or nuclear power which some people view as a necessary evil, some as an unnecessary evil. And what is the best timing for any given investment?

But before I go any further let me make some comments on the international energy prospects over the next 15 years. The comments you will be hearing will

be very similar to those I gave at an energy conference in Halifax some eight months ago.

Figure 1 shows the actual demand for oil in the Western World between 1963 and 1973 with the growth rates in brackets and three potential future growth rates projected from 1975.

During the ten years before 1973 the demand for oil more than doubled, and during the latter few years was growing at the same rate as GNP. Between 1973 and 1975, as a result of the general recession, the demand for oil dropped off in most of the western industrialized countries, but increased slightly in the lesser developed countries. It is perhaps interesting to note that the consumption of the lesser developed countries in 1975 - 20% of the total - was used by 72% of the Western World's population. They hope to improve that ratio significantly under the "New International Economic Order" and OPEC has said that they would help.

Between 1975 and 1990 we show three potential demands for oil based on compounded growth rates of 3.5%, 4%, and 4.5%, respectively. The upper case was designed to show what would happen if economic demand resumed at 4.5% per year and nothing was done to uncouple oil demand from economic growth by conservation or substituting other forms of energy. The 4% growth rate is that predicted in the OECD World energy outlook. These growth rates seem relatively modest in view of the fact that consumption last year was 47.9 million barrels per day - up 6% from 1975. Also the lowest estimate (3.5%) includes U.S. consumption at a rate of 22.3 million barrels per day in 1990 which is only a 2.1% compounded growth rate from their 1975 consumption. In 1976 U.S. consumption was 6.8% over 1975 (Canada's increase was 2.9%).

Figure 2 gives a projection of world oil supply to 1990. In 1975 the

WESTERN WORLD OIL CONSUMPTION

MILLIONS OF BARRELS PER DAY

80
70
60
50
40
30
20
10
0

1963

73 75

80

90

22.9

4.2

5.9

1.2

10.6

1.0

47.4

8.8

14.6

5.4

16.9

1.7

45.2

9.2

13.4

5.0

15.9

1.7

TOTAL (7.5%)

1963-73
LDC's (7.7%)

EUROPE (9.5%)

JAPAN (16.2%)

U.S. (4.8%)

CANADA (5.5%)

81.4 (4.0%)

75.7 (3.5%)

WESTERN WORLD CRUDE OIL PRODUCTION

1975 - 1990

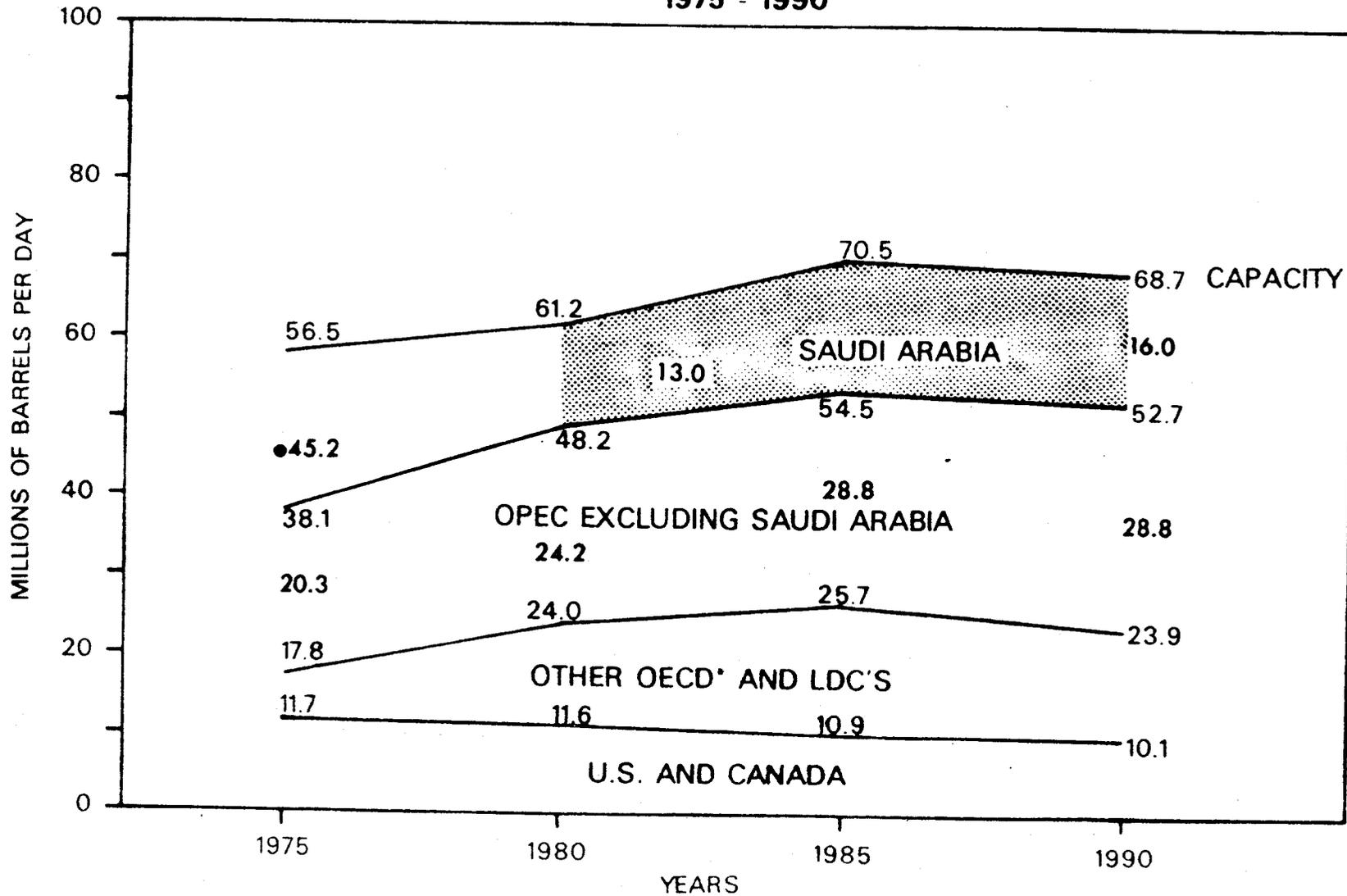

* INCLUDING IMPORTS FROM EASTERN BLOC & CHINA

U.S. and Canada produced 11.7 million barrels per day, Europe and the lesser developed countries 6.1 million barrels per day, OPEC, excluding Saudi Arabia, 20.3 million barrels per day, and Saudi Arabia 7.1 million barrels per day, for a total of 45.2 million barrels per day. Total capacity was 56.5 million barrels per day, a surplus of over 11 million barrels per day.

By 1980 production in the West, excluding OPEC, is expected to rise by approximately 6 million barrels per day principally as a result of increases in North Sea production and Mexico. OPEC capacity is expected to increase as well and Saudi Arabia capacity is expected to be 13 million barrels per day.

By 1985 capacity is expected to have risen to 70.5 million barrels per day mainly as a result of a projected expansion in Iraq plus an expansion of capacity in Saudi Arabia from 13 million barrels per day to 16 million barrels per day, the maximum which they are currently prepared to authorize.

By 1990 capacity will have decreased slightly as a result of production peaking off in the rest of the Western World outside of OPEC and no further expansions in OPEC production.

When we compare estimated demand with capacity (Figure 3) we find that in all cases in 1980 demand is within capacity. In other words, if the rest of the world produced to capacity Saudi Arabia would only have to produce between 5.5 million barrels per day and 8.1 million barrels per day.

By 1985, we have a potential problem. With the rest of the world producing to capacity, Saudi Arabia would have to produce between 9.3 and 15.7 million barrels per day to meet demand. While Aramco - the oil producing consortium in Saudi Arabia - has been authorized to increase production to 16 million barrels per day by 1982, Saudi Arabia could impose a ceiling on oil production at any time if the Arab countries judge that progress toward an Arab/Israel settlement is too slow.

WESTERN WORLD CRUDE OIL PRODUCTION

VS DEMAND

1975 - 1990

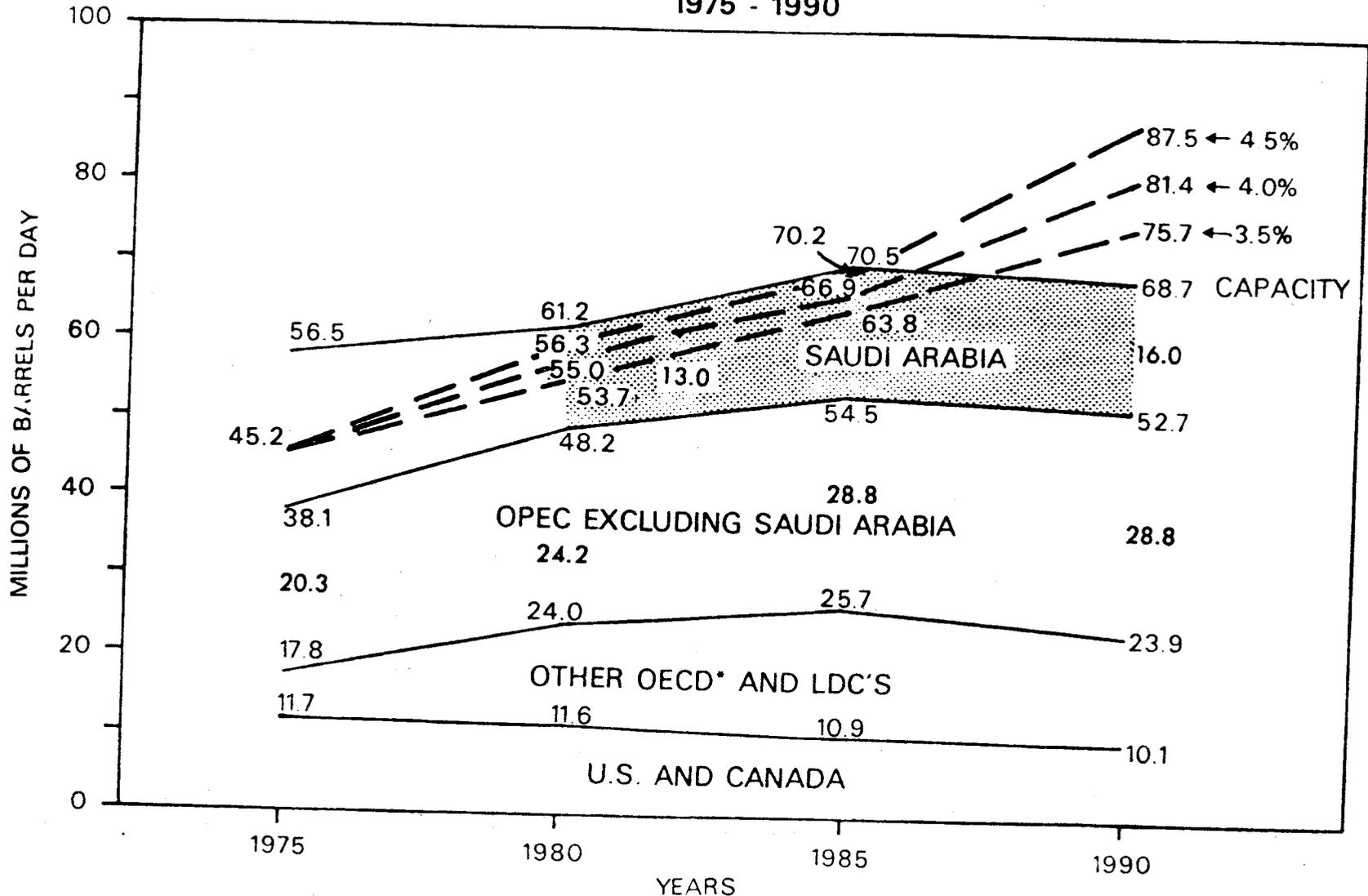

* INCLUDING IMPORTS FROM EASTERN BLOC & CHINA

By 1990, the problem is obvious. At that point, demand at the projected rates would out-strip capacity by 7 million to 19 million barrels per day.

To put it simply, with the rest of the world producing at capacity, Saudi Arabia would have to produce at a minimum rate of 23 million barrels per day and a maximum rate of 35 million barrels per day to meet demand.

The chairman of Aramco has stated that a future production rate of 25 million barrels per day is feasible, but at the moment the only authorized expansion is to an average of 16 million barrels per day.

It appears likely that even under the most optimistic (low) estimate of oil demand growth, demand will reach maximum capacity somewhere between 1985 and 1990 and at that point the OPEC price for oil will probably rise substantially.

You might ask about new discoveries between now and 1990. Certainly there should be some, but consider this; in 1976 the Western World consumed 17.5 billion barrels. Estimated proven reserves in the North Slope are 10 billion barrels and in the North Sea are 23 billion barrels. Put together they would meet our collective needs for only two years at present rates of consumption. Put another way, discoveries of oil over the past fifteen years in North Africa, West Africa, the North Sea and the North Slope total about 100 billion barrels - six years' supply based on current demands. Just over one year's supply at the projected 1990 level of demand. I hope these figures answer the question "Why self-reliance?"

Now, let's return to the domestic scene. Figure 4 is similar to projections made in "An Energy Strategy for Canada", published in 1976, and assumes that oil and natural gas prices have adjusted to international price levels by the late 1970's.

However, Figure 4 also incorporates some new assumptions. The demand curve

FIGURE 4
REVISED
OIL DEMAND AND AVAILABILITY
HIGH PRICE SCENARIO
1970 - 1990

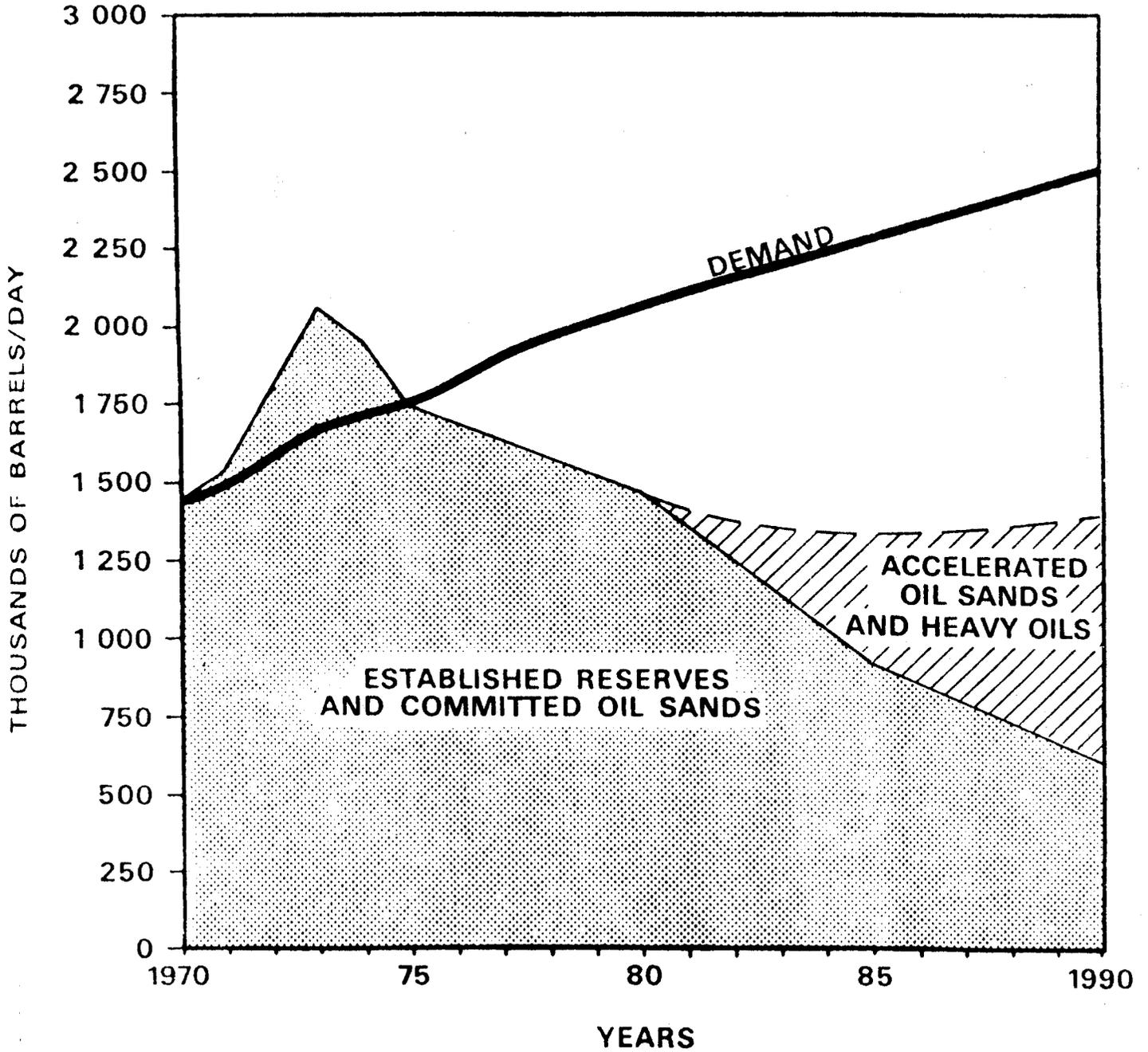

reflects "low" economic growth - not "average" growth as in the "Strategy". On the supply side we have removed any frontier oil - there is none in sight yet, other than the possibility of relatively small tanker deliveries from the Bent Horn District in the High Arctic. We have also updated production estimates from established reserves.

And now let's really be bullish and assume we can overcome the problem preventing a rapid development of oil sands and heavy oils. We pay the price required (at least international prices); we develop new fiscal systems; we build upgrading plants; we overcome environmental and social problems; and we resolve federal-provincial differences. What do we have? Conceivably one million barrels a day by 1990 with capital cost in the range of 15 billion dollars in today's dollars and an operating labour force of up to 20,000. Obviously this is an optimistic target, but when we enter it into the equation, it does little more than compensate for the drop-off in production capacity from our established reserves.

Having been optimistic about supply, let's have another look at demand. What could conservation measures do to that demand curve by 1990? Figure 5 shows a band of conservation impact with a potential 26% reduction in consumption by 1990. This reflects both voluntary and mandatory conservation measures. And yet the gap persists. A gap which has to be met by insecure imported oil or, where possible, by introducing natural gas or other forms into present oil markets (i.e. interfuel substitution). However even that has its limits i.e. transportation usage and most certainly its costs. New developments would have to be accelerated.

Now, let's look at the total energy situation. Let's assess the supply side first and build up our "assured" supplies. These are shown by Figure 6 and consist of:

**FIGURE 5
REVISED
OIL DEMAND AND AVAILABILITY
HIGH PRICE SCENARIO
1970 - 1990**

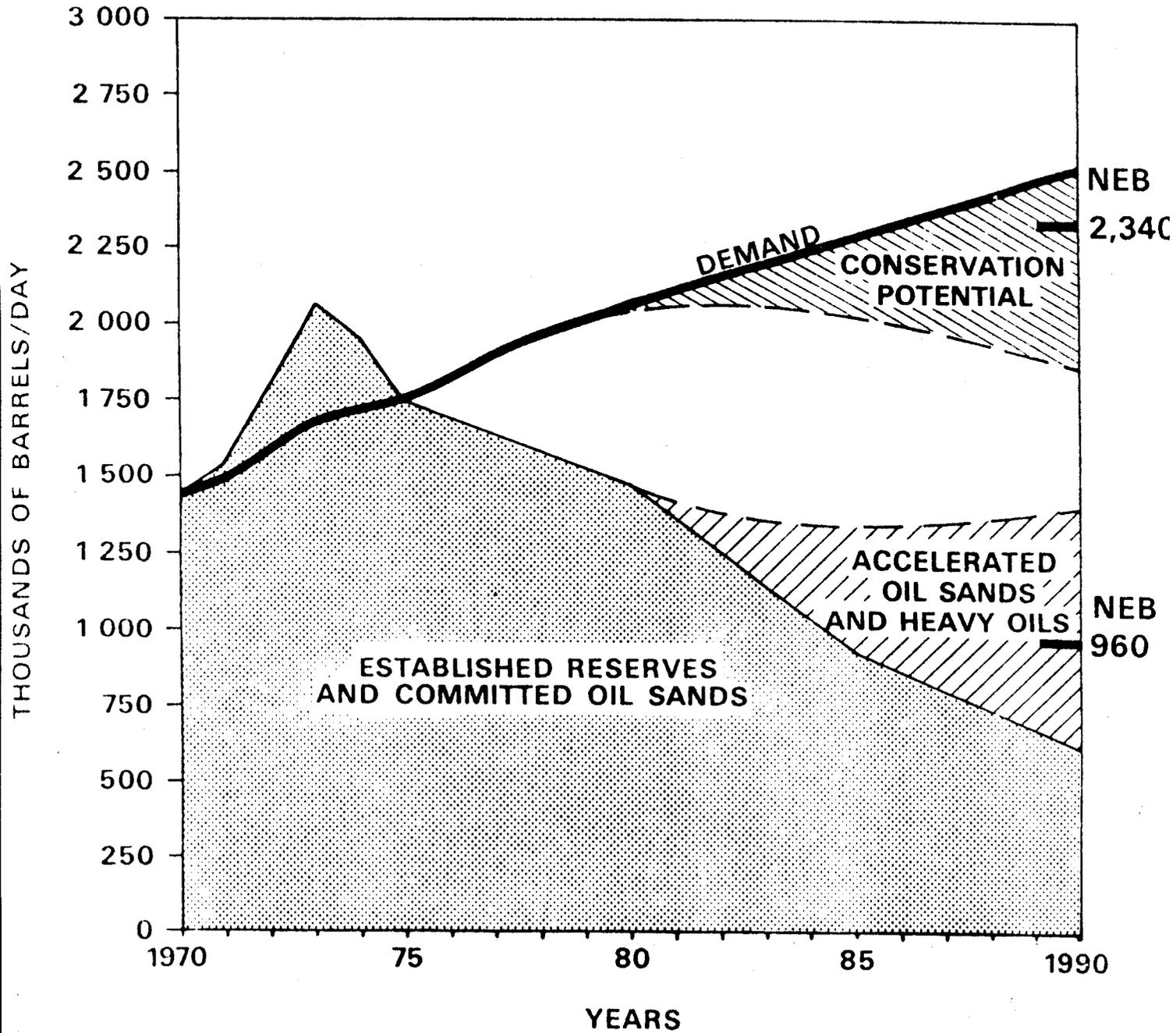

- a) The conventional oil reserves of Western Canada plus the Great Canadian Oil Sands and Syncrude oil sand plants
- b) The gas reserves of the conventional western areas (ignoring the possible impact of Alberta reserve policies)
- c) coal used for non-electrical purposes
- d) existing and under construction electrical generation.

If we stopped new development initiatives at this time these are the only resources which could be available to us. But even here I may be overstating them. For example, 30% of the band of gas supply by 1990 reflects gas which had not yet been found in 1976, and some of that coal will probably be imported.

Now let's assess the demand curve for total primary energy. Figure 7 indicates a range of possibilities varying or extending from the Energy Strategy projection of an average 4% growth rate between now and 1990, to a conservation projection as low as 2.1%. We should not forget that even this highest rate shown assumes that we get our oil prices up to international levels by the late 1970's, a target which our present policy would not achieve. The band of reduced demand shown in Figure 7 reflects such factors as:

- a) a lower rate of economic growth
- b) reduction in gasoline consumption
- c) improved insulation on existing homes
- d) a new building code - applied by everyone
- e) savings in industry, heating systems, appliances, etc.

How successful will we be in our conservation program? Well, the conservation policies which we have launched should ensure we achieve the Energy Strategy Report target of less than 3.5%. But to cut that again to get down to an average growth of 2.1% would clearly require disciplined measures by individuals, corporations and governments. Recent experience has shown no

FIGURE 6
"ASSURED" ENERGY SUPPLIES FOR 1990

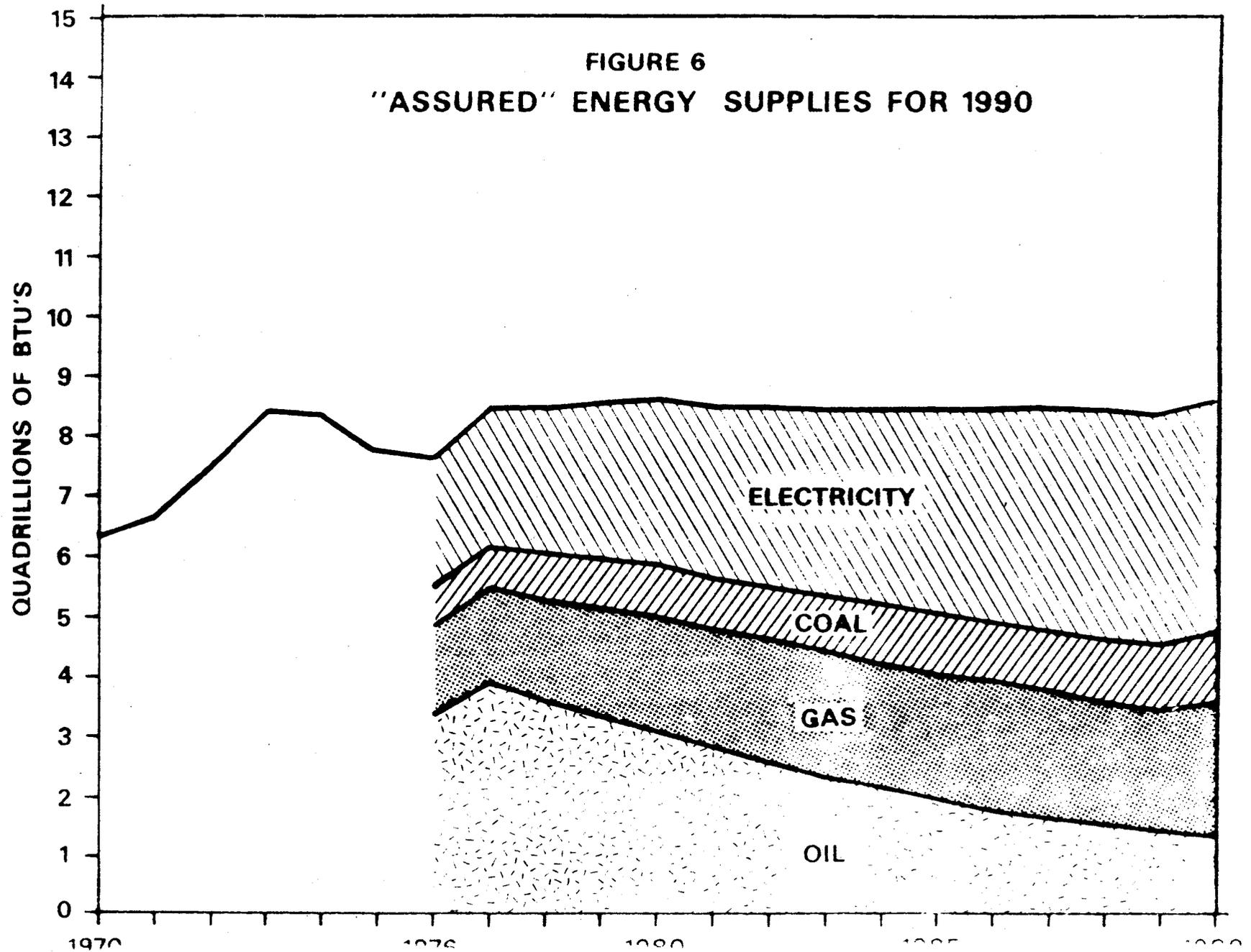

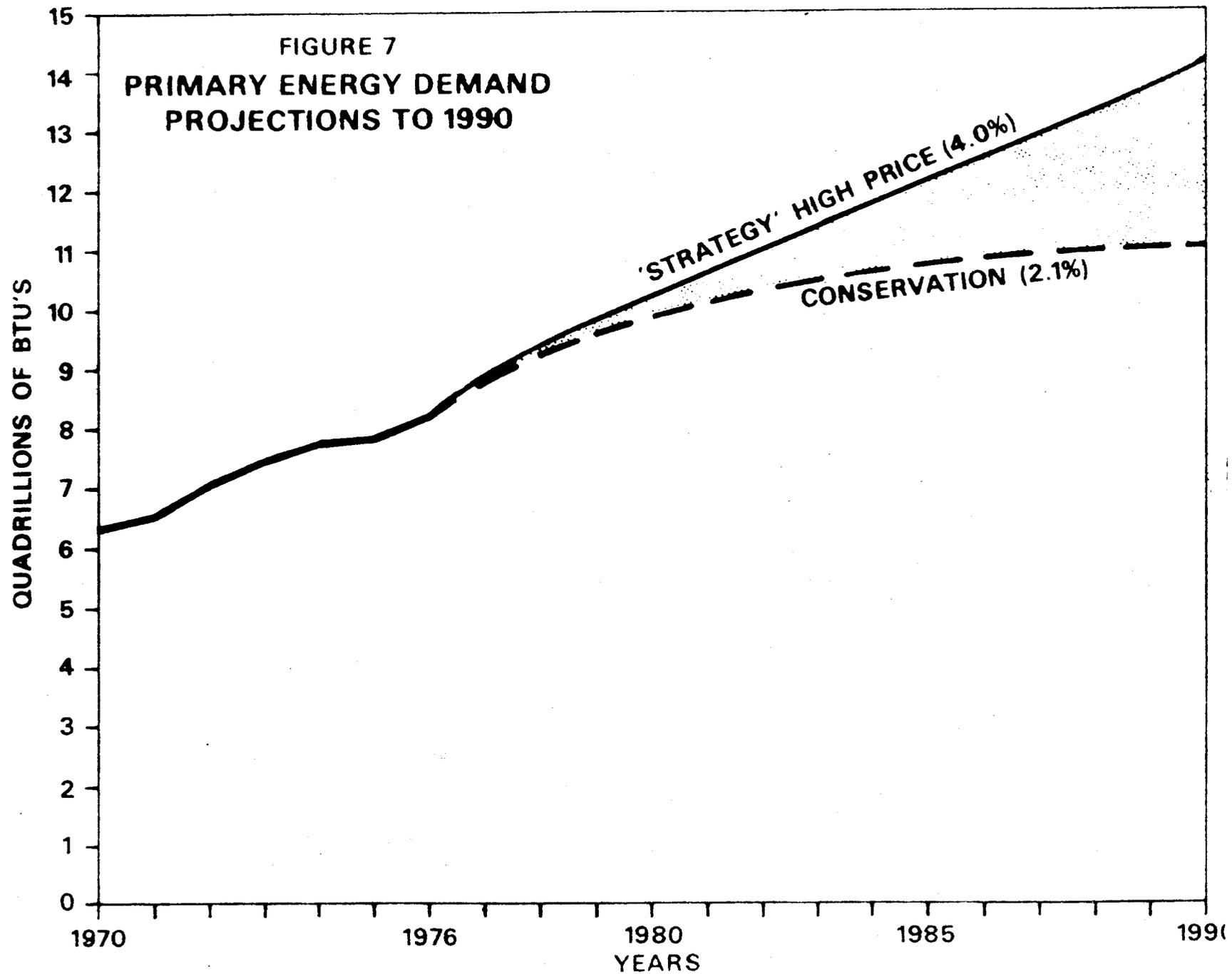

such inclination on the part of many individuals, which suggests that savings of the magnitude shown would have to come largely from imposed measures. Some of these will come; the mile-per-gallon standards for cars and new building codes are two examples. But will the Canadian populace respond positively to the national retrofit program of existing buildings? Will wasteful appliances be banned? Will lower speed limits be respected? Will we drive less? Will we lower thermostats? Will we spurn needless energy intensive packaging? The answers to questions like these will have a major impact on our degree of energy self-reliance by 1990.

Figure 8 compares "assured" supplies with the range of demands. A gap exists even under the extreme "conservation scenario". How can this be closed? Renewable technologies can't do it although they might meet 3% of total demand by 1990. That is not an insignificant amount of energy by the way. It is the equivalent of half the heating load for the projected 5 million single-family dwellings in 1990 - even before conservation savings are achieved.

So all this tells us that new "conventional" energy projects must be developed. How much and when are the unknowns? First of all we have seen from Figure 5 that even with conservation measures and greatly expanded production from our large reserves of oil sands and heavy oils we will still be dependent on imports. The challenges standing in the way of our achieving a target of 1 million barrels a day of production of oil sands and heavy oils by 1990 are immense. So for the purposes of this presentation let's assume in the next chart (Figure 9) that we meet three-quarters of that target.

How do we close the rest of the gap? First we must acknowledge that we have to import some oil and accept the exposure which goes with that. Next we must try to minimize those imports through the development of frontier gas and

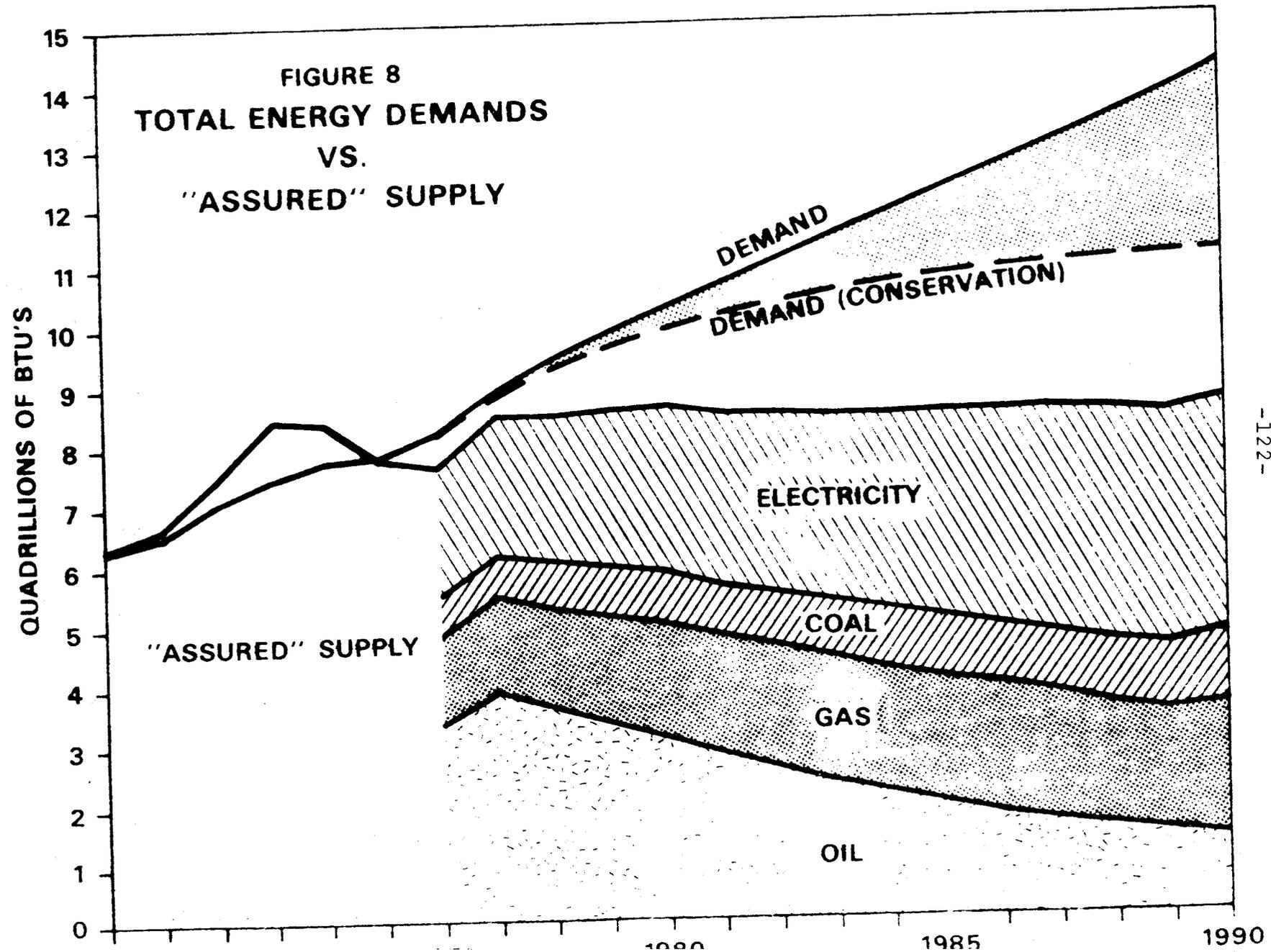

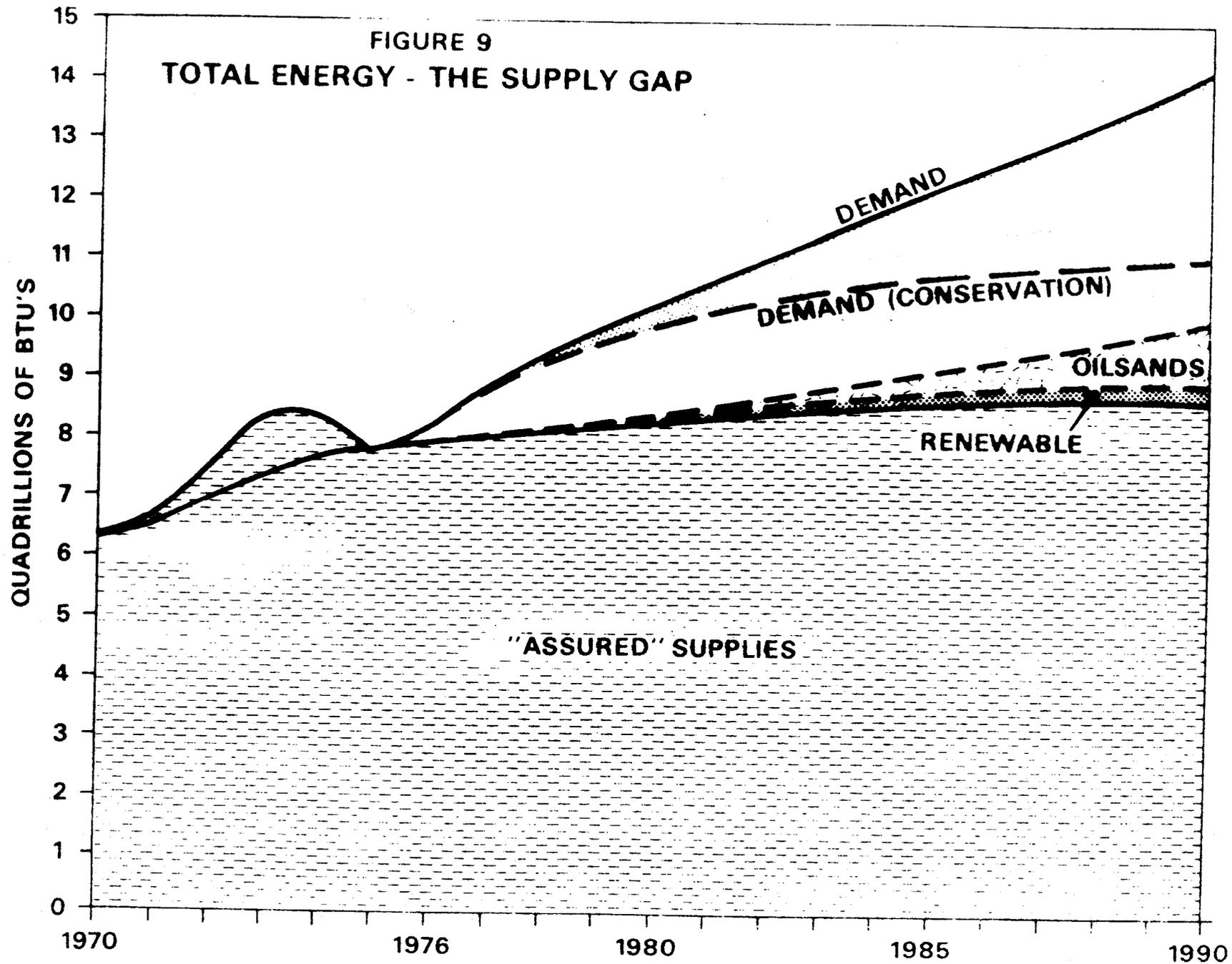

the penetration of gas into markets now served by oil. Next we should pursue the direct use of coal in non-electric applications. And finally, we must accept the fact that large new electrical developments are required. How many depends upon the success of conservation measures but clearly nuclear energy, whether you like it or not, will play an ever increasing role.

The conundrum we must resolve is:

- a) do we rely on conservation savings, reduce development plans and risk potential brownouts in 1990 (enforced conservation),
or
- b) do we plan for something closer to historic growth and pay the added price if it puts us into a surplus situation?

There are no easy answers. However, early answers are required. The lead time needed for construction to meet 1990 needs is disappearing. By 1990 we have to be able to bring into production or import the equivalent of between 9 to 21 new Syn-crudes, or 18 to 42 Pickering's. A formidable challenge for just over 10 years, and that's over and above the projects which are now under construction.

The actions required to meet the challenge are evolving albeit slowly. Conservation initiatives have been pursued. Negotiations are underway for new oil sands and heavy oil production. The proposed Northern Gas Pipeline should ensure access to new gas reserves in the Arctic. Higher prices and exploration incentives have had the desired effect - especially for the gas industry. New hydro has been committed. Increased research is going into new energy sources. However, while all of this will help action at all levels is critical to the closing of the gap. We must conserve, we must develop and we must accept that higher prices for energy will be a fact of life from now on.

This takes me to the contentious issue of oil pricing. Domestic oil prices have been subject to regulatory control since September 1973. Since then the

price has been increased in stages by nearly \$7 to \$10.75 a barrel at the wellhead.

Still, Canadian oil prices remain among the lowest in the industrial world - in Toronto and Montreal, for example, about \$1 a barrel under the prevailing price of oil delivered in Chicago and about \$3.50 less than the landed price of foreign crude oil in Montreal. Figure 10 compares existing and possible future prices in Canada with those in the United States.

Since 1973 we have tempered the increase in oil prices by limiting domestic price increases - and by providing compensating subsidies on foreign oil imported into eastern Canada. Rolland Priddle will be providing you with more detail on the compensation program.

It is important for all of us to acknowledge that the producing provinces have been making a substantial contribution to national unity in the face of the divisive pressures created by the sharp change in our energy situation. They have agreed to supply depleting oil and natural gas resources at prices that are substantially below world levels to the rest of the country. No other provinces have volunteered to subject themselves to such constraints on their resources.

I feel I should also respond to the frequent allegations that the federal government is reaping large new net revenues from the higher crude oil and natural gas prices as well as from the excise tax on gasoline. Table 1 shows that federal energy expenditures have roughly equalled federal energy revenues over recent years. Furthermore, federal income tax revenue from oil and gas production profits is influenced greatly by the extent to which the industry decides to reinvest its share of these incremental revenues.

For example, the federal government's take from two one-dollar increases taking place on July 1, 1977 and January 1, 1978 will depend on the level of

FIGURE 10
 PROJECTED CANADIAN AND U.S. CRUDE OIL PRICES
 CANADIAN ESCALATED AT \$1.00 EVERY SIX MONTHS
 \$1.00 CAN = \$0.95 U.S.

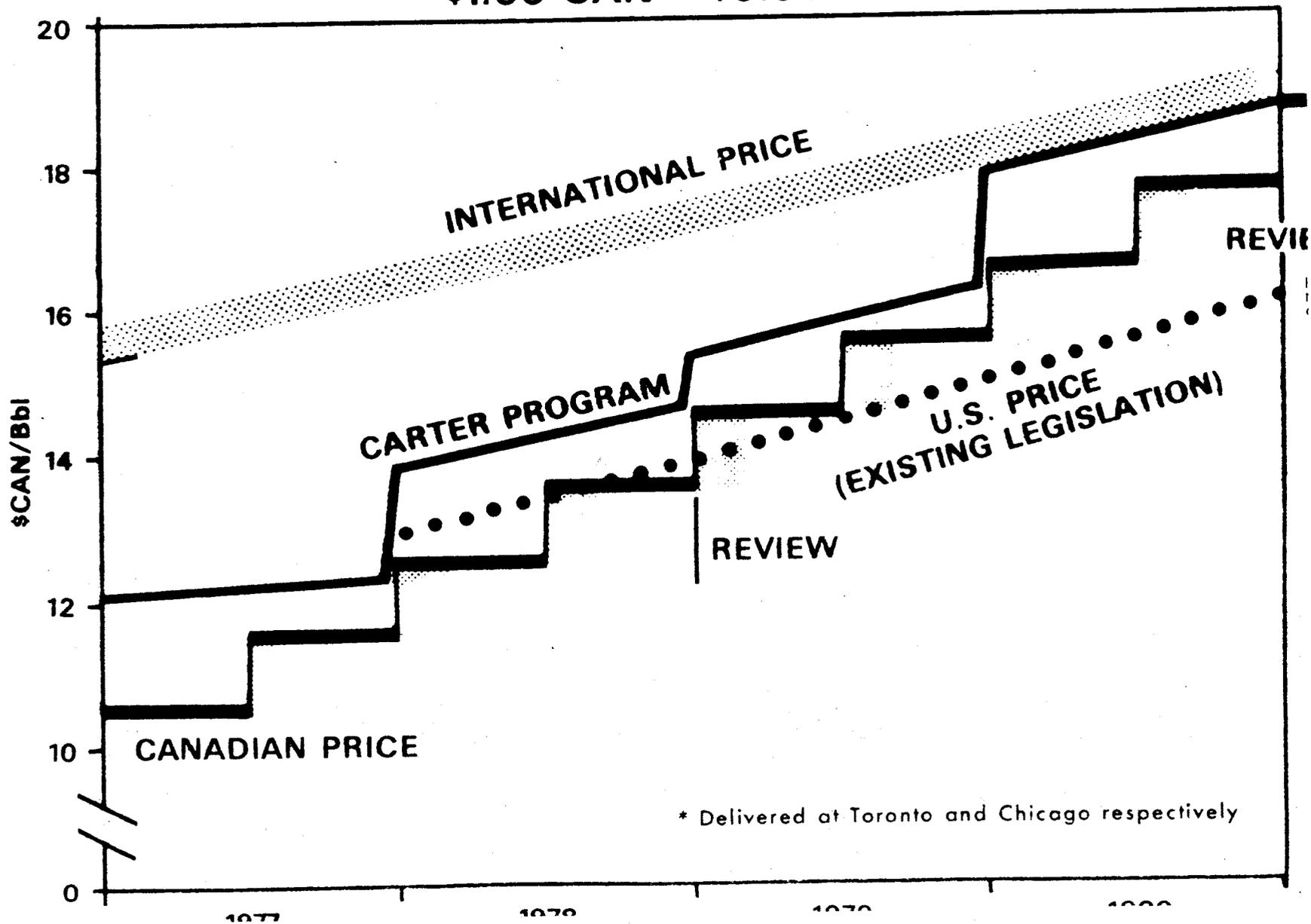

TABLE 1
 FEDERAL GOVERNMENT'S ENERGY-RELATED EXPENDITURES AND OIL- AND GAS-
 RELATED REVENUES 1973-77 IN MILLIONS OF DOLLARS

	1973-74	1974-75	1975-76	1976-77
ENERGY EXPENDITURES				
Oil Compensation Payments	157.0	1,162.0	1,582.0	945.3
Additional Equalization Payments attributable to Prov. Oil & Gas Revenues (assuming a \$2 increase in 1977-78)	253.0	370.0	448.0	484.0
Energy R & D	106.0	105.0	114.0	120.0
Energy Conservation				67.5
Other Energy Projects	<u>55.0</u>	<u>105.0</u>	<u>330.0</u>	<u>475.6</u>
TOTAL EXPENDITURES	571.0	1,742.0	2,474.0	2,092.4
OIL AND GAS RELATED REVENUES				
Oil Export Charge	287.0	1,669.0	1,063.0	660.0
Gasoline Tax			399.0	557.8
Corporate Income Tax	<u>220.0</u>	<u>504.0</u>	<u>770.0</u>	<u>862.0</u>
TOTAL REVENUES	507.0	2,173.0	2,232.0	2,079.8
BALANCE OF OIL AND GAS RELATED REVENUES LESS ENERGY EXPENDITURES	(64.0)	431.0	(242.0)	(12.6)

reinvestment by the industry. If 1976 is an indication of future investment behaviour, about \$280 million of the increased cash flow will be reinvested by industry. This would leave the federal government - after increased equalization payments to the provinces - with about \$50 million. In addition, there is a \$35 million tax credit earned by the industry and usable against income in future years.

The net potential gain to the federal treasury is therefore insignificant when compared to the federal government's commitments to energy development and conservation; e.g. Petro-Canada, the home insulation program and additional energy R&D.

I should also point out that the contribution of the petroleum industry to federal tax revenues reflects the preferential treatment given the industry during its earlier stage of development. Over the period 1947-72 federal income taxes amounted to approximately \$700 million out of total gross revenues of \$20 billion (3.5%). Even without the rapidly increasing value of the commodity since 1973 the federal tax take would have been expected to increase as the earning base of the industry matured.

