

University of Groningen

Socioeconomic Inequality and Student Outcomes in the Netherlands

Scheerens, Jaap; Timmermans, Antje; van der Werf, Greetje

Published in:
Socioeconomic Inequality and Student Outcomes

DOI:
[10.1007/978-981-13-9863-6_7](https://doi.org/10.1007/978-981-13-9863-6_7)

IMPORTANT NOTE: You are advised to consult the publisher's version (publisher's PDF) if you wish to cite from it. Please check the document version below.

Document Version
Publisher's PDF, also known as Version of record

Publication date:
2019

[Link to publication in University of Groningen/UMCG research database](#)

Citation for published version (APA):

Scheerens, J., Timmermans, A., & van der Werf, G. (2019). Socioeconomic Inequality and Student Outcomes in the Netherlands. In L. Volante, S. V. Schnepf, J. Jerrim, & D. A. Klinger (Eds.), *Socioeconomic Inequality and Student Outcomes* (pp. 111-132). (Education Policy & Social Inequality; Vol. 4). Springer. https://doi.org/10.1007/978-981-13-9863-6_7

Copyright

Other than for strictly personal use, it is not permitted to download or to forward/distribute the text or part of it without the consent of the author(s) and/or copyright holder(s), unless the work is under an open content license (like Creative Commons).

The publication may also be distributed here under the terms of Article 25fa of the Dutch Copyright Act, indicated by the "Taverne" license. More information can be found on the University of Groningen website: <https://www.rug.nl/library/open-access/self-archiving-pure/taverne-amendment>.

Take-down policy

If you believe that this document breaches copyright please contact us providing details, and we will remove access to the work immediately and investigate your claim.

Downloaded from the University of Groningen/UMCG research database (Pure): <http://www.rug.nl/research/portal>. For technical reasons the number of authors shown on this cover page is limited to 10 maximum.

Chapter 7

Socioeconomic Inequality and Student Outcomes in the Netherlands



Jaap Scheerens, Anneke Timmermans and Greetje van der Werf

Abstract In this chapter, we address the educational outcomes of students with low socioeconomic status (SES), both Dutch and with an immigrant background. We indicate how these outcomes have developed over time, and how this development might be related to educational policy measures that seek to enhance the educational opportunities for students with a disadvantaged background. We start with a description of the Dutch school structure and note that the highly tracked secondary school level and high school autonomy are significant features. Next, we provide a short description of the share of low SES parents and primary school students, and how these have evolved over time during the period 2008–2017, while distinguishing between Dutch and immigrant background. The main body of the chapter provides an overview of the outcomes of low SES and immigrant students in primary and secondary education. Finally, we critically comment on the effectiveness and efficiency of the Dutch educational equity policy.

Keywords Student achievement · Socioeconomic status · Inequality · The Netherlands

J. Scheerens (✉)
University of Twente, Enschede, The Netherlands
e-mail: j.scheerens@utwente.nl

A. Timmermans · G. van der Werf
University of Groningen, Groningen, The Netherlands

© Springer Nature Singapore Pte Ltd. 2019
L. Volante et al. (eds.), *Socioeconomic Inequality and Student Outcomes*, Education Policy & Social Inequality 4,
https://doi.org/10.1007/978-981-13-9863-6_7

7.1 Introduction: The Dutch School System¹

7.1.1 *The School Structure*

Figure 7.1 depicts the school structure in the Netherlands. There are perhaps two features that are particularly worth mentioning. The first is that there is a strong vocational strand, manifested by specialized vocational schooling at the junior and senior secondary level (vmbo and mbo). The second related feature is the strong structural differentiation or tracking at the secondary level combined with a relatively early selection moment for a particular track at the end of primary school.

Full-time education is compulsory from the age of 5 to the age of 16, but pupils can (voluntary) enter primary education at the age of 4. Students who have not acquired a start qualification for the labor market when they leave full-time education are required to follow part-time education until the age of 18. The Dutch education system is divided into three levels: primary, secondary, and tertiary education. Primary schools in the Netherlands cater for children from 4 to 12 years of age. Schools are usually arranged into 8-year groups. Grade retention during primary education is possible and whether a child is retained a grade is decided by the school the child attends. Children in need of special care and attention can attend special schools. Depending on the type of special educational needs, a child can be admitted to specialized schools.

Secondary education is divided into the following:

- Practical education (pro), 12–16 years, for students with special educational needs
- Junior vocational education (vmbo), 12–16 years. This type of education consists of four different tracks: the basic vocational track, preparing students for the lowest levels of senior vocational education (mbo), and the advanced vocational, the theoretical, and the mixed track, each of which prepares students for the two highest levels of senior vocational education. Students who have completed the theoretical or mixed track also can continue in senior general secondary education (havo, see below)
- Senior general secondary education (havo), 12–17 years, preparing for higher professional education or universities for applied sciences (hbo)
- Pre-university education (vwo), 12–18 years, preparing students for university.

Evidently, the system of secondary education is strongly stratified, both within and between schools. After primary education, pupils are selected into one or sometimes two adjacent tracks described above (Korpershoek, Naaijer, & Bosker, 2016). Selection is currently only informed by the primary school teachers' track

¹This section is based on Scheerens, Ehren, Slegers, and De Leeuw (2012) and Nusche, Braun, Halasz, and Santiago (2014). The latter study is a review of educational evaluation and assessment in the Netherlands by the Organisation for Economic Co-operation and Development (OECD); the former study is a national pre-study to the OECD review.

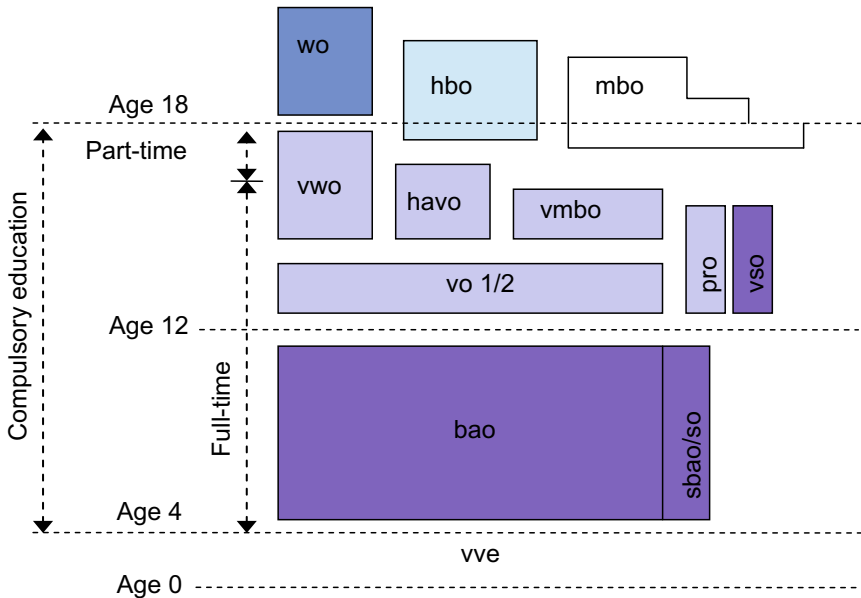

Legend:

- bao** Mainstream primary education
- havo** General secondary education
- hbo** Higher professional education
- mbo** Vocational education
- pro** Practical training
- sbao** Special primary education
- so** Special needs education
- vmbo** Pre-vocational secondary education
- vve** Early childhood education
- vso** Special needs education secondary level
- vwo** Pre-university education
- wo** University education

Fig. 7.1 The Dutch school system

recommendation. Before 2015, track selection was informed by student performance during primary education and the teachers' track recommendation (Timmermans, Kuyper, & van der Werf, 2013). The brightest students attend havo and vwo; the others go to vmbo schools. For many students, the track in which they were selected is decisive for their educational careers; however, grade retention and intermediate upward and downward mobility are possible.

From 1993 onwards, a shared curriculum for students during the first 3 years of secondary education was the official policy (the so-called *Basisvorming* or basic general education). The introduction of basic general education could be seen as an attempt to introduce comprehensive schooling. Despite this attempt, the reality in

most schools is streaming in which the differentiation at the upper secondary level is already “foreshadowed.” In this respect, the attempt to introduce comprehensive schooling was not successful. The failure of the *Basisvorming* is documented in the 2008 report of the ‘Parliamentary Inquiry Committee Educational Innovations’ (Ministry of Education, 2008).

At the upper secondary level, the differentiation consists of a havo, a vwo, and a vocational stream of upper secondary education (see below). Diplomas from the havo and vwo track are considered a basic qualification for entering the labor market. In these differentiations/tracks, students choose a particular set of school subjects (or profiles) at the end of grade 3, when the students are approximately 15 years old. In the vmbo tracks, the decision about school subjects is already made at the end of grade 2, when the students are approximately 14 years of age. This latter choice is very decisive as the choices in senior secondary vocational education are highly restricted by the set of school subjects chosen in vmbo (Vugteveen, Timmermans, Korpershoek, van Rooijen, & Opdenakker, 2016). For the havo and vwo tracks, the choice of profiles is, although important, less restrictive for further choices.

Senior vocational education, 16–20 years, is divided into four levels of training:

Level 1: training to assistant level, 6 months–1 year

Level 2: basic vocational training, 2–3 years

Level 3: professional training, 2–4 years

Level 4: middle-management training, 3–4 years, or specialist training, 1–2 years

Adult Education

The purpose of adult education, unlike vocational education, is not to train students for a particular occupation but rather to provide a solid foundation for vocational and secondary education courses and to enable adults to participate in society (social and life skills).

Tertiary education is divided into the following:

- higher professional education (hbo)
- university education (wo)
- open higher distance education (Open University).

Given the scope of this chapter, no further details about adult education and tertiary education will be provided.

7.1.2 Governance

7.1.2.1 School Autonomy and Freedom of Education

The Netherlands has one of the OECD’s most devolved education systems, with schools enjoying a high degree of autonomy. Responsibility for education is shared

almost entirely between schools and the central government, with no significant intermediate level of educational administration. With regard to ensuring teaching quality, the Dutch Government describes the distribution of responsibilities for educational reform as follows: “the government will establish the objectives of the policy measures (what) while the field itself will decide how best to pursue those objectives (how).”

School autonomy is grounded in the principle of “freedom of education,” which is guaranteed by the Dutch Constitution since 1917. Freedom of education gives the right to any natural or legal person to set up a school, to organize teaching, and to determine the (educational, religious, or ideological) principles on which teaching is based. This constitutional arrangement puts public and private schools on an equal footing, with all schools receiving public funding provided that they meet the requirements for schools in their sector. Parents have free school choice, and funding “follows the student,” which lays the foundation for potentially strong competition among schools (Nusche et al., 2014, pp. 20–21).

7.1.2.2 Central Steering and Support

The Ministry of Education, Culture and Science has the responsibility for the overall education system, but it does not interfere with the organization of individual schools. The Ministry’s responsibilities relate mainly to setting legislation and determining the structure and funding mechanisms of the education system. It can also control the system by setting quantitative or qualitative standards, attainment targets, and examinations. The Minister of Education is also responsible for the evaluation of the quality of education, which is carried out by the Dutch Inspectorate of Education.

Schools and school boards are responsible for ensuring quality at the school level, and the Inspectorate of Education checks that they do so effectively by means of monitoring student performance and school visits. There is also a large intermediary structure of organizations originally created to serve the interests of pressure groups that used to be organized according to religious denominations. In the 1990s, several of these bodies were secularized and merged into Councils for each of the educational sectors. The Council for Primary Education (PO-raad), the Council for Secondary Education (VO-raad), and the Council for Senior Vocational Education (MBO-raad) represent the employers (school boards) of their respective sectors and offer support services to schools, such as a team of “flying brigades” that work with schools identified by the Inspectorate as weak or very weak (Nusche et al., 2014, p. 22).

7.2 Distribution of Socioeconomic Status (SES) Among the Dutch Population and the Students in Primary Education

Parents' educational level is the regular indicator for SES that is used in the Netherlands by researchers, the Central Bureau of Statistics, and the Inspectorate and is usually operationalized as the highest level of education completed by one or both of the students' parents. Because the data that we will present in this chapter are mainly based on secondary sources, we will only use the parental level of education as an indicator of SES. Unfortunately, there is no consistency in the categorization of the level of education based on SES among the different sources. For this reason, we will, where appropriate, explain the details of the different categories of SES when discussing the tables. Also, because the category of low SES students includes a very substantial number of students with a migrant background, who—until very recently—were explicitly one of the most important target groups of the Dutch educational equity policy, we will present the data separately for Dutch students and students with a immigrant (Western and non-Western) background as often as possible.

Table 7.1 shows the distribution of the level of education in the Dutch population across the period from 2010 until 2017, in proportions of the total number of 15–65-year olds belonging to the inhabitants of the Netherlands with respectively a Dutch, a Western, or non-Western immigration background. The data are derived from population data available at Statistics Netherlands, which uses the following categorization of SES: Low = primary education, vmbo, junior havo, or junior vwo (grade 1–3) or mbo1 (no start qualification); Middle = senior havo or vwo, or mbo level 2, 3, or 4 (start qualification); High = Bachelor or Master from higher professional education or university, or a Ph.D. The data show that in all three groups (Dutch, Western, and non-Western background), the share of low SES people in the population is declining over time. The decline is strongest among the people with a non-Western background, from 46.4% in 2010 to 36.6% in 2017, and smallest among inhabitants with a Dutch background, from 31.8% in 2010 to 28.2% in 2017. Nevertheless, the share of low SES people in the population remains the largest among the people with a non-Western migration background.

Table 7.2 shows the distribution of students in kindergarten and primary school across the three levels of SES and migration background across the period 2008 through 2014, in percentages of the total number of students in each year in kindergarten, grade 3, and grade 6 classes, respectively. The data are based on the COOL^{5–18} cohort study reported in Driessen, Mulder, Ledoux, Roeleveld, and Van der Veen (2009), Driessen, Mulder, and Roeleveld (2012), and Driessen, Elshof, Mulder, and Roeleveld (2015). COOL^{5–18} is a large-scale cohort study monitoring student's educational career from age 5 (kindergarten) to age 18. Data collection took place every 3 years (in 2008, 2011 and 2014), in kindergarten, grade 3 and grade 6 of primary school and Grade 9 of secondary school. SES categories were defined in COOL^{5–18} as follows: Low = both parents have completed at the highest

Table 7.1 Educational level of the Dutch population between 15- and 65-year-olds from 2010 to 2017

Migration background	SES	2010	2011	2012	2013	2014	2015	2016	2017
Dutch	Low	0.318	0.324	0.321	0.303	0.300	0.296	0.295	0.282
	Middle	0.403	0.400	0.397	0.398	0.401	0.400	0.398	0.398
	High	0.273	0.269	0.275	0.286	0.292	0.299	0.302	0.312
Western	Low	0.310	0.316	0.296	0.262	0.266	0.256	0.247	0.248
	Middle	0.368	0.362	0.364	0.403	0.406	0.395	0.399	0.398
	High	0.314	0.314	0.330	0.304	0.304	0.323	0.327	0.329
Non-Western	Low	0.464	0.443	0.416	0.375	0.398	0.400	0.390	0.366
	Middle	0.335	0.345	0.366	0.404	0.380	0.368	0.366	0.379
	High	0.191	0.199	0.202	0.177	0.182	0.189	0.199	0.207

Source: Central Bureau voor de Statistiek (2008)

Table 7.2 Level of parental education for students in Dutch Kindergarten, Grade 3, and Grade 6 classes

SES	Migration background	Kindergarten			Grade 3			Grade 6		
		2008	2011	2014	2008	2011	2014	2008	2011	2014
Low	Dutch	12.2	9.5	8.5	13.4	9.9	8.4	16.7	11.8	9.0
	Non-Western	8.3	5.5	5.8	8.8	5.8	6.9	9.1	6.0	6.3
Middle	Dutch	40.2	38.6	37.6	40.1	38.9	39.6	39.2	39.9	40.3
	Non-Western	5.4	5.1	6.5	5.0	4.7	5.7	4.5	4.4	5.8
High	Dutch	31.0	37.5	37.4	30.4	37.7	35.7	28.1	35.2	35.5
	Non-Western	2.8	3.8	4.2	2.2	2.9	3.8	2.4	2.6	3.0

Note Numbers in the table are based on survey data with the following sample sizes

Kindergarten 2008 $N = 10069$; 2011 $N = 9261$; 2014 $N = 7279$

Grade 3 2008 $N = 9288$; 2011 $N = 10109$; 2014 $N = 7449$

Grade 6 2008 $N = 8545$; 2011 $N = 9444$; 2014 $N = 7909$

Sources Driessen et al. (2009, Table 4.4); Driessen et al. (2012, Table 4.4); Driessen et al. (2015, Table 4.4)

vmbo; Middle = one of the parents or both parents have completed at the highest havo, vwo or mbo; High = one of the parents or both parents have completed higher professional education or university. Furthermore, it is important to note that the minority status of the students is based on the country of birth of the parents. Migrant parents who were born in a Western country were included in the category Dutch. In a family with a mixed background, the country of birth of the mother was leading. In case of a one-parent family, the data of that parent was leading.

The data in Table 7.2 show that during the period 2008 through 2014, the SES level of the students in kindergarten and primary school increased, both among students with a Dutch (or Western migration) background and students with a non-Western immigration background. This is due to an increase in the percentage of higher educated and a decrease in the percentage of lower educated parents. For

example, for the final grade of primary education (grade 6) the percentage of Dutch students with highly educated parents increased from 28.1% in 2008 to 35.5% in 2014. The percentage of students from middle SES families remained rather stable in this time frame.

7.3 Socioeconomic Background and Student Outcomes

The tables presented in this section illustrate the differences in educational outcomes of students according to the level of SES of their family, and when the data are available, also to their migration background. In the description, we focus on primary and secondary education, for which data on both attainment and achievement² indicators are available. In addition, for primary education only data on non-cognitive outcomes are reported. For senior vocational, higher professional, and university education we only present data on attainment indicators, like participation, drop-out, and graduation rates.

7.3.1 Student Outcomes in Primary Education

7.3.1.1 Cognitive Outcomes and Attainment in Grade 6

Table 7.3 shows the development of the performance of students in year 8 (comparable to U.S. grade 6) over the years 2008, 2011, and 2014, as well as the track recommendation students received at the end of primary school, separately for the three levels of SES and the categories Dutch and migrant students (see also Table 7.2). The data are based on the reference group of schools participating in the COOL^{5–18} cohort studies in primary education, which is representative of the population of Dutch primary schools.

The performance scores include the composite score (range of scores 501–550) on the final school leaving test, a highly reliable high stakes test, consisting of the domains mathematics, Dutch language, and information processing. The table also presents student outcomes on the knowledge and skills part of a Citizenship Competence test, taken in the COOL^{5–18} cohort studies (range of scores 0–1 and 1–4, respectively). The data on the track recommendation include the percentage of students who were recommended to one of the academic tracks—that is, recommendation for havo, vwo, or combined havo/vwo track in secondary education.

The data in Table 7.3 show that the scores on the final school leaving test of the Dutch students are almost stable over time. The difference between the lowest and

²Attainment indicators refer to formal levels of education; achievement indicators are based on test scores or examination marks.

Table 7.3 Student average performance scores and attainment (in percentages) in Grade 6 of primary education, 2008–2014

	Low SES						Middle SES						High SES					
	Dutch		Migrant		Dutch		Migrant		Dutch		Migrant		Dutch		Migrant			
	<i>M</i>	<i>SD</i>	<i>M</i>	<i>SD</i>	<i>M</i>	<i>SD</i>	<i>M</i>	<i>SD</i>	<i>M</i>	<i>SD</i>	<i>M</i>	<i>SD</i>	<i>M</i>	<i>SD</i>	<i>M</i>	<i>SD</i>		
Final school leaving test	2008	529.1	10.2	527.6	10.1	534.1	9.5	531.8	10.1	539.1	8.3	532.9	10.4					
	2011	530.7	9.4	528.8	9.2	534.2	8.8	531.9	10.2	539.4	7.7	536.7	8.7					
	2014	528.5	10.3	528.7	10.6	533.2	10.0	531.8	10.5	538.5	9.1	536.5	9.9					
Civic knowledge	2008	0.73	0.17	0.70	0.17	0.77	0.16	0.74	0.17	0.82	0.16	0.75	0.18					
	2011	0.73	0.17	0.71	0.16	0.78	0.16	0.73	0.16	0.83	0.14	0.78	0.13					
	2014	0.71	0.18	0.69	0.17	0.77	0.17	0.73	0.16	0.83	0.15	0.77	0.15					
Civic skills	2008	2.96	0.40	3.13	0.40	2.99	0.39	3.16	0.42	3.05	0.38	3.08	0.42					
	2011	2.95	0.42	3.12	0.41	2.97	0.39	3.13	0.43	3.04	0.37	3.10	0.41					
	2014	2.93	0.45	3.17	0.45	2.99	0.40	3.16	0.42	3.05	0.38	3.17	0.40					
Percentage havo/vwo recommendation	2008	20.8		17.8		39.1		37.5		64.3		40.1						
	2011	21.5		18.2		38.3		33.9		64.6		51.0						
	2014	20.9		23.6		36.1		33.7		63.3		55.1						

Note Numbers in the table are based on survey data with the following sample sizes: 2008 $N = 8545$; 2011 $N = 9444$; 2014 $N = 7909$.

Sources Driessen et al. (2009, Tables 9.8, 10.4, 10.6); Driessen et al. (2012, Tables 10.8, 11.4, 11.6); Driessen et al. (2015, Tables 10.8, 11.4, 11.6)

highest SES group is around 10 points in every year, which is a difference of approximately one standard deviation. For the students with a migrant background, we see a similar picture over time. Comparing the data between Dutch and migrant students shows that for each SES category, the differences are very small. As regards the scores on the citizenship competences, we also see little changes over time. The higher the level of SES, the higher the scores are. A striking result is that the students with a migrant background score lower on civic knowledge, but higher in civic skills, which holds for each SES category.

Also, for track recommendation, we hardly see any changes over time with respect to the influence of SES, at least for the Dutch students. The percentages of students who receive a recommendation for the highest tracks in secondary education are similar in every year, with a difference between the highest and lowest level of SES of around 40%. In contrast, the percentage of students with a migrant background who receive a higher recommendation is increasing over time. However, this is only due to the migrant students in the highest SES category. As a consequence, the difference between low- and high-SES migrant students who receive a high track recommendation increased from around 20% in 2008 to 35% in 2014. Further studies of the track recommendations indicate that the differences in recommendations between high- and low-SES students remain existent, although more modestly, after taking the students' performance into account. These differences in track recommendations are very dependent on the particular primary school a student is attending (Timmermans, Kuyper, & van der Werf, 2015), and they cannot be explained by differences in the teachers' perceptions of work habit and engagement of these students (Timmermans, de Boer, & van der Werf, 2016). One of the most frequently mentioned explanations is that teachers take into account the parents' ability and resources to support their children (Ditton et al., 2005). Teachers deem parents from lower SES backgrounds to be less well equipped to assist their children with school work. Furthermore, parents from higher social classes exert more pressure on teachers to get academic track recommendations (e.g., Dronkers et al., 1998), while poorly educated parents rarely object to low track recommendations (Hillmert & Jacob, 2010).

7.3.1.2 Non-cognitive Outcomes

According to the Dutch Inspectorate of Education (Inspectie van het Onderwijs, 2014), Dutch students in primary and secondary education do like school very much but are on the other hand not very motivated to learn and to perform. This finding was confirmed by the Organisation for Economic Co-operation and Development (2016a) in its report about the Netherlands, which showed that the Dutch students score almost the lowest on motivation of all countries participating in the OECD studies. However, both the Inspectorate and the OECD did not present data about the relation with SES and how this relation developed over time. In Table 7.4, we present data from the COOL⁵⁻¹⁸ cohort study collected in 2008, 2011, and 2014 on

Table 7.4 Student well-being with teachers and classmates and motivation (average score) in Grade 6 of primary education

	Low SES						Middle SES						High SES					
	Dutch		Minority		Dutch		Minority		Dutch		Minority		Dutch		Minority			
	M	SD	M	SD	M	SD	M	SD	M	SD	M	SD	M	SD	M	SD		
Well-being with the teacher	2008	3.66	0.64	3.64	0.68	3.67	0.65	3.67	0.71	3.66	0.65	3.61	0.75					
	2011	3.72	0.65	3.68	0.70	3.73	0.65	3.68	0.73	3.76	0.63	3.65	0.69					
	2014	3.69	0.66	3.70	0.73	3.73	0.66	3.68	0.73	3.73	0.66	3.68	0.76					
Well-being with classmates	2008	4.13	0.67	4.22	0.58	4.18	0.64	4.18	0.64	4.15	0.63	4.15	0.64					
	2011	4.14	0.65	4.24	0.64	4.19	0.65	4.24	0.66	4.19	0.65	4.21	0.65					
	2014	4.16	0.69	4.25	0.64	4.21	0.67	4.22	0.64	4.19	0.65	4.24	0.64					
Mastery motivation	2008	3.64	0.58	3.98	0.60	3.66	0.56	3.99	0.62	3.71	0.57	3.92	0.58					
	2011	3.67	0.57	3.94	0.59	3.69	0.56	3.97	0.58	3.74	0.54	3.96	0.59					
	2014	3.67	0.63	4.06	0.60	3.70	0.57	4.03	0.60	3.75	0.58	4.06	0.54					
Performance motivation	2008	1.92	0.72	2.17	0.87	1.97	0.72	2.24	0.85	2.06	0.73	2.17	0.84					
	2011	1.97	0.76	2.31	0.90	1.95	0.76	2.22	0.87	2.06	0.77	2.27	0.89					
	2014	1.98	0.79	2.41	0.95	1.97	0.76	2.28	0.91	2.08	0.79	2.33	0.94					

Note Numbers in the table are based on survey data with the following sample sizes: 2008 $N = 8545$; 2011 $N = 9444$; 2014 $N = 7909$
Sources Driessen et al. (2009, Tables 8.4, 8.5, 8.10); Driessen et al. (2012, Tables 9.4, 9.5, 9.10); Driessen et al. (2015, Tables 9.4, 9.5, 9.10)

grade 6 students' well-being and motivation, again differentiated according to level of SES and migration background. The data on well-being (Peetsma, Wagenaar, & de Kat, 2001) and motivation (Ali & McInerney, 2004) were collected by means of a student questionnaire (score range 1–5).

Students indicate a relatively high level of well-being with their teacher and an even higher level of well-being with their classmates. There is hardly any difference in well-being between the different SES groups and only a small difference between Dutch and migrant students, in the advantage of the last category. With respect to the two indicators of motivation, the data show clearly that both Dutch as well as migrant students are more intrinsically motivated (mastery motivated, willing to learn) than motivated to perform. Higher SES students, both migrant as well as Dutch, are a bit more motivated (mastery and performance) than low SES students. But the most striking is that in all categories of SES, minority students are much more motivated than their Dutch classmates.

7.3.2 Student Outcomes in Secondary Education

7.3.2.1 Attainment Indicators

In the following, we first present data on student attainment in secondary education, followed by data on their performance in PISA. Because of the highly tracked system of secondary education in the Netherlands, already at the stage of the transition from primary to secondary school socioeconomic inequality may develop or even increase. In Table 7.5 we present data from the Dutch Inspectorate on students' track placement in grade 1 in secondary education, distinguished according to the level of SES. The Inspectorate used the original data on parental education of Statistics Netherlands, which imply that five categories were distinguished instead of three. The levels 1 and 2 in Table 7.5 are in agreement with (see Table 7.1) low SES (no start qualification), level 3 is similar to middle SES (start qualification), and level 4 and 5 are similar to high SES (higher professional or university). The figures in the table include the percentages of students who were placed in the track that corresponded with their score on the final school leaving test, respectively, half or one track lower or higher.

Table 7.5 shows that, in general, there is a very clear relation between the level of parental education and the chance of being placed in a higher school track compared to the track that might be expected given the students' performance. For example, in 2016 only 10% of the students with parents in the lowest category of education (Senior vocational education level 1, low SES) was placed one track higher than expected compared to 21% of the students with the highest educated parents (higher professional or University education, high SES). Furthermore, the chance of a higher track placement than indicated by the score on the final school leaving test increased over time for each category of SES. Nevertheless, this increase is more substantial among the students from higher SES families than

Table 7.5 Chance (in %) on being placed in a higher or lower track in secondary education compared to the expected track placement given the students' performance on the school leavers test

Parental education	Year	One track lower	Half track lower	Corresponding track	Half track higher	One track higher
Secondary vocational education level 1, low SES	2014	12	23	43	14	7
	2015	17	24	39	12	7
	2016	14	22	40	14	10
Secondary vocational education level 2 & 3, low SES	2014	11	22	43	15	9
	2015	14	22	39	14	10
	2016	11	20	40	17	12
Secondary vocational education level 4, middle SES	2014	9	21	42	17	11
	2015	12	21	39	15	13
	2016	9	19	40	18	15
Higher professional education, high SES	2014	6	18	43	19	13
	2015	8	19	41	17	16
	2016	6	16	39	20	19
University education, high SES	2014	3	14	49	20	19
	2015	4	14	45	20	17
	2016	2	12	43	22	21

Note Population data

Source Inspectie van het Onderwijs (2017)

among lower SES students. At the same time, the decrease in placement in lower tracks is higher for high SES students compared to students from lower SES families. All together, these data point to the conclusion that the already existing socioeconomic inequality due to the Dutch tracked system is increasing instead of decreasing. This is even more serious because track placement in the first grade of secondary school foreshadows the rest of the school career of students in secondary education in terms of promotion/degradation to a lower or higher track, drop-out, completed level of secondary education, and transition to senior vocational education and higher professional education and university. Figures of the Inspectorate (Inspectie van het Onderwijs, 2017) show that students in grade 9 of secondary education from the lowest SES categories have a much lower chance to be promoted to a higher track. Also, these students have a much higher chance of having to repeat a grade or to be referred to a lower track.

7.3.2.2 Student Performance

Table 7.6 includes the average performance scores of the Dutch students on the PISA assessment in 2015, for the domains mathematics, reading, and science. The level of education of the parents was based on students' reports (1% primary

Table 7.6 Results of Dutch students in the PISA 2015 assessment given the level of parental education

Parental education	Mathematics	Reading	Science
Primary education not completed	430	425	427
Primary education or vmbo	463	455	451
havo/vwo/mbo	501	488	492
hbo/wo	524	516	523
<i>Migration background</i>			
Dutch	520	510	517
Migrant second generation	474	470	462
Migrant first generation	452	434	438

Note Numbers are based on PISA data. $N = 5.385$

Source Feskens, Kuhlemeier, and Limpens (2016)

education not completed, 5% primary education or vmbo completed, 30% havo/vwo/mbo completed, and 64% higher professional education or university completed), as well as their migrant background, based on the country of birth of their parents.

Fifteen-year-old students originating from a high SES family (higher professional education/university completed) perform better in all three domains than students from lower educated parents. The differences are very large; the average difference between the lowest and highest SES category is around one standard deviation for all three domains.

The data regarding migration background in Table 7.6 show that immigrant students achieve less well than native Dutch students on all three domains of science, readings skills, and mathematics. The difference between native Dutch students and second-generation immigrants is very large: the largest for science (55 points), the smallest for reading (40 points), and mathematics in between (46 points). The differences between the second and third generation are not relevant, though it is interesting that the largest difference is for reading. Unfortunately, it is not possible to compare the data per SES category between Dutch students and students with a migration background. However, an interesting performance indicator developed in PISA is the performance gap between immigrant and non-immigrant students. Results for science performance, established in PISA 2015, indicate that the unadjusted performance gap for the Netherlands was 60 points on the PISA scale, above the OECD average gap of 43 points. When looking at this indicator after adjustment for socioeconomic background the Dutch gap reduced to 33 points, while the OECD average gap reduced to 31 (Organisation for Economic Co-operation and Development, 2016b, Table 1.7.4a, p. 427). These figures show the strong determination of performance differences by socioeconomic background (this is a finding that applies across OECD countries, but quite strongly

in the Netherlands). In comparison to results from PISA 2006, which also had science performance as the focal subject matter domain, the gap in 2015 was 16 points lower than in 2006, for unadjusted performance, where the gap at the OECD average reduced by 9 points. When considering the results adjusted for socioeconomic background, the gap in the Netherlands was reduced by 10 points while the OECD average showed a 6-point decrease in the gap (Organisation for Economic Co-operation and Development, 2016b, Table 1.7.15a, p. 440).

The trends shown on the basis of PISA 2006 and 2015 for science performance—namely a slow decrease of the gap between immigrant and non-immigrant students over time, the important influence of SES on the estimate of the performance gap, and the Netherlands scoring close to the OECD average on the estimates adjusted for SES—are corroborated by the results from PISA 2003 and 2012 with respect to mathematics performance. Between 2003 and 2012 the performance gap in mathematics between immigrant and non-immigrant students decreased from 66 points in 2003 to 57 in 2012 for the unadjusted results, and from 41 to 35 for the adjusted results (Organisation for Economic Co-operation and Development, 2013, Tables II3.4a, II3.4b, pp. 228–229). The overall picture from these data is that the achievement differences between Dutch and immigrant students have declined over time, that a large part of the differences can be explained by the level of education of immigrant students' parents, but that the influence of immigrant background nevertheless remains important for student performance in secondary education. Also, the performance gap related to SES is still rather impressive although it slightly improved during the period 2003–2015.

Another way to determine whether countries and economies are moving towards more equitable school systems is to see how they have promoted student resiliency. Resilient students are disadvantaged students (those in the bottom quarter of a country's or economy's distribution of SES) who perform in the top quarter of performance in all countries, after accounting for SES (Organisation for Economic Co-operation and Development, 2013, p. 41). Countries and economies in which the proportion of students who are resilient is growing are those that are improving the chances for disadvantaged students to become high achievers.

In PISA 2003, 6.4% of students in OECD countries were resilient; by 2012, this share had decreased slightly to 6.1%. Only in Germany, Italy, Mexico, Poland, Tunisia, and Turkey did the share of resilient students increase by more than one percentage point. In 11 countries and economies, the share of resilient students shrank—meaning that in these countries/economies it became less likely that disadvantaged students will perform at a high level. The resiliency score for the Netherlands remained virtually unchanged between 2003 and 2015, at a level slightly above the OECD average.

7.3.3 *Attainment in Senior Vocational Education, Higher Professional Education, and University*

To conclude this section, we present population data on SES related attainment of students who transfer from lower secondary education (vmbo) to senior vocational education, as well as from students who, coming from the two highest levels of secondary education (havo/vwo), continue their education career in higher professional education or university. The former is the educational sector where students can attain their start qualification for the labor market, the latter prepares for the well-paid jobs.

As regards the first category of students, the Dutch Inspectorate of Education (2017) showed that in the academic year 2014/2015 students from low SES families have a higher drop-out rate in senior vocational education than students from higher SES families. More detailed analyses of the data, taking into account several background characteristics of the students, like family income and migration background, show that students with a migrant background drop-out more often than Dutch students. Among Dutch students, the chance of getting a diploma is higher when their parents have a higher level of education or income.

Table 7.7 includes the percentages of students with a secondary school degree (havo, vwo, or senior vocational education level 4) who registered in higher professional education or university, distinguished by the level of education (SES) of their parents. The data are from the period 2008 through 2016. We see that there is a rather large SES related difference in the chance to continue the school career in higher education. The SES gap has become larger since 2015, which might be due to the fact that in that year the study grant for higher and university education was replaced by a study loan.

Table 7.7 Registration (in %) of students with a secondary school degree to higher professional and university education

Parental education	2008	2009	2010	2011	2012	2013	2014	2015	2016
Only primary education	65.7	66.2	63.9	62.3	60.9	62.2	59.0	57.3	58.0
Secondary vocational education level 1	66.2	64.3	61.9	60.5	59.8	60.8	58.7	54.3	55.4
Secondary vocational education level 2	65.4	65.7	61.5	62.5	60.2	59.6	59.1	55.6	56.6
Secondary vocational education level 3	70.2	71.6	69.0	68.2	67.4	67.7	67.5	63.2	62.1
Secondary vocational education level 4	75.8	75.7	75.3	74.5	73.7	74.5	72.3	69.9	70.2
Higher professional education	81.0	82.3	81.7	81.4	80.9	81.5	81.3	78.2	78.7
University education	87.4	87.7	87.1	86.1	86.5	88.0	87.6	85.1	85.2

Source Inspectie van het Onderwijs (2017)

7.4 Policy to Enhance Equity in Education in the Netherlands

Current and most recent developments in equity-oriented policies in Dutch primary and pre-primary education should be understood from a historical perspective spanning about 40 years.

The most constant policy instrument used in the Dutch equity-oriented policy has been the extra funding of schools based on school composition (Scheerens, 2014). Low SES and cultural minority students count as more than one student in the formulas for the school budget, which are based on the number of students enrolled. In the past (from 1986 to 2006) native Dutch students with low educated parents counted for 1.25 students and students with a non-Western immigrant background counted as 1.90. In the current “weights regulation”, a distinction between native Dutch and non-Western immigrant students is no longer made. Only the level of education of the parents determines the weight factor. Students whose (both) parents have completed at maximum lower vocational education count as 1.3, students of whom one of the parents have just completed primary education and the other only preparatory lower vocational education count as 2.2. Schools are eligible for extra funding when they have a certain percentage of students meeting the selection criteria for educational priority (see above); and, since the 2006/2007 school year, the threshold has been lowered from 9 to 6%. Since 2010, eligible schools in the so-called Impulse areas, zip code areas that are determined as poverty areas, receive another increment in their budget over and above the student weight-based formula.

Schools are expected to spend the extra funding on measures that enhance the position of their disadvantaged learners, but they are free to decide how they do so; extra teaching and support staff, partly used for class-size reduction, and bringing in external support are the main “treatments” that schools are likely to choose. Driessen (2018) concludes that the extra funding is predominantly spent on class-size reduction, although precise information on these funding decisions is hard to come by because schools cannot be held accountable for how they spend their budget. Moreover, the effectiveness of limited class-size reduction is quite doubtful. Finally, there are no evaluation studies that can attribute results of equity-oriented policies to the actual treatments that schools implement on the basis of their extra funding, not only because of local control over the use of the funding, but also because of frequent refusals from schools to participate in research and evaluation studies. Thanks to a long tradition of cohort studies, outcomes that are most relevant to equity-oriented policies can be monitored quite well, but it is very difficult to find schools that are ready to cooperate in experimental or process-outcome evaluation studies (Scheerens & Doolaard, 2013).

The most recent development is a proposal from the Central Bureau of Statistics (Central Bureau voor de Statistiek) to compute a new composite indicator to determine the level of disadvantage of the school, including education levels of mother and father, country of origin of the mother, duration of stay in the

Netherlands, and being eligible for debt compensation. This proposal is contested because it no longer identifies disadvantaged students, but just provides a school level estimate, on which funding is based. Critics say that this further perils the proper and targeted use of extra funding (Driessen, 2018).

From 1998 onward, pre-school education (vve) became a second major target area for equity-oriented policy, next to regular primary education. The reason for this policy was that pre-school education was considered to be a good measure for preventing SES related educational inequality. The policy levers are exactly the same as described above: extra funding based on the “weights regulation,” and pre-school institutions and schools free to choose treatments. Until now, the results of studies on the effectiveness of vve programs are not consistently positive and the effects on the longer term are still unknown (Centraal Planbureau, 2016).

Since 2010 extra measures have been stimulated by the government and key stakeholders, like employers of education. These involve different kinds of pull-out strategies, where special classes are formed of eligible students who get extra treatment like additional Dutch language education and extended learning time (longer school day, school week, or summer schools). Finally, equity stimulation more recently got an extra boost, when it was profiled as a dedicated component of more general educational policy that is aimed at enhancing quality and performance—known as *Basis voor Beter Presteren* (Driessen, 2013; Mulder & Meijnen, 2013).

7.5 Conclusion

When making up the balance on the position of low SES students in Dutch education, the strongly suppressing influence of low SES has been re-confirmed. This is also the case when concentrating on low SES students from immigrant groups. When considering student performance at the end of primary school, the influence is almost stable over time. The difference between the lowest and highest SES group is around 10 points every year. For the students with a migrant background, we see a similar SES related difference over time. Comparing the performance data between Dutch and migrant students shows that for each SES category, the differences are very small and almost stable over time.

As regards the performance in secondary education, also the SES influence is substantial and hardly decreasing over time. In comparison to other countries, the performance of both Dutch and immigrant students in secondary education depends on a relatively large share of their SES background. Taking the SES background into account, the performance difference between Dutch and immigrant students is slowly decreasing over time.

A similar picture regarding the influence of SES holds for the track recommendations students receive at the end of primary school and the actual track placement. Recommendations for higher track education are three times bigger for high than for low SES students. For Dutch students, the influence of SES on track recommendations has stayed stable as well. Only middle SES Dutch pupils have

experienced a decline in their recommendations. In contrast, the percentage of students with a migrant background who receive a higher recommendation is increasing over time. Migrant students with high SES status experienced the highest increase, but are still 8 percentage points less likely to receive a recommendation than their Dutch counterparts. As a consequence, the difference between low and high SES migrant students who receive a high track recommendation increased from around 20% in 2008 to 35% in 2014, a finding which points to an increase of socioeconomic inequality among migrant students.

All together, the performance data of primary and secondary education show that the socioeconomic inequality in the Netherlands is very substantial and persistent, in contrast to inequality related to migration background, which is almost absent at the end of primary education and decreasing in secondary education. The same holds for track recommendation and track placement, i.e. stable large SES related differences and no or very small differences between Dutch and migrant students. Also regarding attainment indicators in secondary education (drop-out, continuation to tertiary education) the socioeconomic inequality is still rather substantial and most recent data on continuation to tertiary education even show that this inequality is increasing. Because data about difference over time between Dutch and immigrant students, taking SES into account, are not available, nothing can be yet concluded about migration-related inequality.

When it comes to an assessment of the effectiveness and efficiency of the equity-oriented policies in the Netherlands, there is a striking consensus among all evaluators and reviewers of these policies. They invariably point to the lack of coherence, clear planning frameworks, and limited evaluability of the way schools use extra funding and work towards the rather general policy objectives (Driessen, 2018; Driessen & Mulder, 1999; Mulder & Meijnen, 2013; Scheerens, 1987). The implicit message is that school autonomy has long gone over the edge in the Netherlands and is preventing policies that are effective and efficient. In the most recent evaluation study, Mulder and Meijnen (2013) are very explicit in their recommendations to have clearer targets from the center, more explicitly planned programs, stricter accountability requirements, and better conditions for program evaluation. The inefficiency in equity-oriented policy is part of a larger syndrome in Dutch education, in which innovation and reform are framed to be “bottom up,” leading to many fragmented local initiatives in which the wheel is reinvented over and over again (Scheerens, 2013, 2014). Despite the recommendations in practically all evaluation studies, the counsel to make better use of evidence-based comprehensive school reform programs has never been followed up in a consistent way, so far (although there is a very recent initiative to implement the “Success for All” program in the Netherlands).

In summing up the basic situation of the Netherlands with respect to SES determinacy of educational outcomes, seen from an international perspective, the following points should be mentioned:

- Internationally, the Netherlands has an average position when the student level SES impact on performance is considered.
- The SES-related gap in student performance and attainment is substantial and persistent over time in primary and secondary education and increasing in tertiary education.
- The gap in student performance between migrants and Dutch students, taking into account the level of SES, is absent and stable over time in primary education, and declining over time in secondary education.
- The gap in student attainment between migrant and Dutch students, taking into account the level of SES, is absent and stable over time at the end of primary education (recommendation and track placement).
- The highly diversified structure of the secondary school system seems to reinforce inequalities, for instance when it comes to the high impact of SES on track placement and school drop-out. Another instance is the very high between-school variance in performance (Scheerens, 2014).
- Grossly inefficient educational policy to weaken SES determinacy of performance and increase equity (no demonstrable effects of very high financial investments).

References

- Ali, J., & McInerney, D. M. (2004). Multidimensional assessment of school motivation. In H. W. Marsh, J. Baumert, G. E. Richards, & U. Trautwein (Eds.), *Self-concept, motivation and identity: Where to from here?* Sydney, Australia: SELF Research Centre, University of Western Sydney. Retrieved from <https://www.researchgate.net/publication/314434491/download>.
- Central Bureau voor de Statistiek. (2018, August 14). *Statline: Bevolking; onderwijsniveau; geslacht, leeftijd en migratieachtergrond* [Population; education level; sex, age and migration background]. Retrieved from <http://statline.cbs.nl/Statweb/publication/?DM=SLNL&PA=82275NED&D1=0&D2=0&D3=1&D4=1,4-5&D5=0-1,7,12,1&D6=39,44,49,54,59,64,69,74-75&HDR=T,G1,G5,G2&STB=G3,G4&VW=T>.
- Centraal Planbureau. (2016). *Kansrijk Onderwijsbeleid* [Promising education policy]. The Hague, The Netherlands: Author. Retrieved from <https://www.cpb.nl/publicatie/kansrijk-onderwijsbeleid>.
- Ditton, H., Krüsken, J., & Schauenberg, M. (2005). Bildungsungleichheit – der Beitrag von Familie und Schule. *Zeitschrift für Erziehungswissenschaft*, 8, 285–304. <https://doi.org/10.1007/s11618-005-0138-x>.
- Driessen, G. (2013). *De bestrijding van Onderwijsachterstanden* [Fighting educational inequality: A review of effective approaches]. Nijmegen, The Netherlands: ITS.
- Driessen, G. (2018, April 1). Zo doorgaan met het onderwijsachterstandsbeleid [Should we carry on with the educational priority in this way?] [Web log post]. Retrieved from <https://didactiefonline.nl/blog/blonz/zo-doorgaan-met-het-onderwijsachterstandenbeleid>.
- Driessen, G., Elshof, D., Mulder, L., & Roeleveld, J. (2015). *Cohortonderzoek COOL⁵⁻¹⁸*. *Technisch rapport basisonderwijs, derde meting* [COOL⁵⁻¹⁸ cohort study: Technical report primary education, third measurement]. Amsterdam, The Netherlands: Kohnstamm Instituut. Retrieved from <https://www.bvekenis.nl/Bibliotheek/16-1106.pdf>.

- Driessen, G., & Mulder, L. (1999). The enhancement of educational opportunities of disadvantaged children. In R. J. Bosker, B. P. M. Creemers, & S. Stringfield (Eds.), *Enhancing educational excellence, equity and efficiency*. Dordrecht, Boston, London: Kluwer.
- Driessen, G., Mulder, L., Ledoux, G., Roeleveld, J., & Van der Veen, I. (2009). *Cohortonderzoek COOL⁵⁻¹⁸. Technisch rapport basisonderwijs, eerste meting 2007/08* [COOL⁵⁻¹⁸ cohort study: Technical report primary education, first measurement 2007/08]. Amsterdam, The Netherlands: SCO-Kohnstamm Instituut.
- Driessen, G., Mulder, L., & Roeleveld, J. (2012). *Cohortonderzoek COOL⁵⁻¹⁸. Technisch rapport basisonderwijs, tweede meting 2010/11* [COOL⁵⁻¹⁸ cohort study: Technical report primary education, second measurement 2010/11]. Amsterdam, The Netherlands: Kohnstamm Instituut.
- Dronkers, J., van Erp, M., Robijns, M., & Roeleveld, J. (1998). Krijgen leerlingen in de grote steden en met name in Amsterdam te hoge adviezen? *De relaties tussen taal- en rekenscores en advies binnen en buiten de Randstad onderzocht*, *Tijdschrift voor Onderwijsresearch*, 23, 17–30.
- Feskens, R., Kuhlemeier, H., & Limpens, G. (2016). *Resultaten PISA 2015 in vogelvlucht. Kennis en vaardigheden van 15-jarigen*. [PISA 2015 results in bird's eye view: Knowledge and skills of 15-year-olds]. Arnhem, The Netherlands: Cito. Retrieved from <https://www.lezenenschrijven.nl/uploads/editor/resultaten-pisa-2015-in-vogelvlucht.pdf>.
- Hillmert, S., & Jacob, M. (2010). Selections and social selectivity on the academic track: A lifecourse analysis of educational attainment in Germany. *Research in Social Stratification and Mobility*, 28, 59–76. <https://doi.org/10.1016/j.rssm.2009.12.006>.
- Inspectie van het Onderwijs. (2014). *De Staat van het Onderwijs 2012/2013* [The state of education 2012/2013]. Utrecht, The Netherlands: Author.
- Inspectie van het Onderwijs. (2017). *Technisch rapport hoofdstuk 1—Gelijke kansen. De Staat van het Onderwijs 2015/2016* [Technical report chapter 1—Equal opportunities. The state of education 2015/2016]. Utrecht, The Netherlands: Author.
- Inspectorate of Education. (2017). *Technisch rapport Hoofdstuk 1 - Gelijke kansen. De Staat van het Onderwijs 2015/2016*. Utrecht: Author.
- Korpershoek, H., Naaijer, H. M., & Bosker, R. J. (2016). *De inrichting van de onderbouw: Onderzoek naar de motieven en de beweegredenen van vo-scholen naar soort brugklas* [The layout of the substructure: Research into the motives of secondary schools by type of bridge class]. Groningen, The Netherlands: GION onderzoek/onderwijs.
- Ministry of Education. (2008). *Parlementair onderzoek Onderwijsvernieuwingen* [Parliamentary study on educational innovations]. Kamerstukken II 2007–2008, 31 007, nr. 8.
- Mulder, L., & Meijnen, W. (2013). *Onderwijsachterstanden in de BOPO-periode, 2009–2012. Een review* [Inequality in primary education in the period 2009–2011. A review study]. Nijmegen, The Netherlands: ITS.
- Nusche, D., Braun, H., Halasz, G., & Santiago, P. (2014). *OECD reviews of evaluation and assessment in education: Netherlands 2014*. Paris, France: OECD Publishing.
- Organisation for Economic Co-operation and Development. (2013). *PISA 2012 results: Excellence through equity* (Vol. II). Paris, France: OECD Publishing.
- Organisation for Economic Co-operation and Development. (2016a). *Netherlands 2016: Foundations for the future—Reviews of national policies for education*. Paris, France: OECD Publishing. <https://doi.org/10.1787/19900198>.
- Organisation for Economic Co-operation and Development. (2016b). *PISA 2015 results: Excellence through equity* (Vol. I). Paris, France: OECD Publishing.
- Peetsma, T. T. D., Wagenaar, E., & De Kat, E. (2001). School motivation, future time perspective and well-being of high school students in segregated and integrated schools in the Netherlands and the role of ethnic self-description. In J. K. Koppen, I. Lunt, & C. Wulf (Eds.), *Education in Europe: Cultures, values, institutions in transition* (pp. 54–74). New York, NY: Waxmann.
- Scheerens, J. (1987). *Enhancing opportunities for disadvantaged learners: A review of Dutch research on compensatory education and educational development policy*. Amsterdam, The Netherlands: North-Holland Pub. Co.

- Scheerens, J. (2013). *Educational Evaluation and Assessment in the Netherlands*. Addendum to the Country Background Report for the OECD Review on Evaluation and Assessment Frameworks for Improving School Outcomes. www.oecd.org/education/school/Netherlands%20CBR%20Update.pdf.
- Scheerens, J. (2014). *Country report on The Netherlands, concerning equity oriented educational policies and programs*. Contribution to the network of experts on social aspects of education and training (NESET) under the auspices of the European Commission. Unpublished manuscript.
- Scheerens, J., & Doolaard, S. (2013). *Review study on educational quality of Dutch primary schools*. Enschede, The Netherlands: GION/University of Twente.
- Scheerens, J., Ehren, M., Slegers, P., & De Leeuw, R. (2012). *Country background report for the OECD study on Evaluation and Assessment Frameworks for Improving School Outcomes*. Retrieved from <http://www.sici-inspectorates.eu/getattachment/caf46482-5270-4bc6-b985-2bdf75b57e5f>.
- Timmermans, A. C., de Boer, H., Amsing, H. T. A., & van der Werf, M. P. C. (In press). Track recommendations bias: Gender, migration background and SES bias over a twenty-year period in the Dutch context. *British Educational Research Journal*. Retrieved from <http://hdl.handle.net/11370/30914514-de3f-4388-93e8-1b64542d252b>.
- Timmermans, A. C., de Boer, H., & van der Werf, M. P. C. (2016). An investigation of the relationship between teachers' expectations and teachers' perceptions of student attributes. *Social Psychology of Education, 19*(2), 217–240. <https://doi.org/10.1007/s11218-015-9326-6>.
- Timmermans, A., Kuyper, H., & van der Werf, G. (2013). *Schooladviezen en onderwijsloopbanen: Voorkomen, risicofactoren en gevolgen van onder- en overadviesing* [School recommendations and educational careers: Prevention, risk factors and consequences of under- and over-advice]. Groningen, The Netherlands: GION/RUG Onderwijskunde.
- Timmermans, A. C., Kuyper, H., & van der Werf, G. (2015). Accurate, inaccurate, or biased teacher expectations: Do Dutch teachers differ in their expectations at the end of primary education? *British Journal of Educational Psychology, 85*(4), 459–478. <https://doi.org/10.1111/bjep.12087>.
- Vugteveen, J., Timmermans, A. C., Korpershoek, H., van Rooijen, M., & Opendakker, M.-C. (2016). *Overgangen en aansluitingen in het onderwijs: Deelrapportage 3: empirische studie naar de cognitieve en niet-cognitieve ontwikkeling van leerlingen rondom de vmbo-mbo overgang* [Transitions and connections in education: Partial report 3: empirical study on the cognitive and non-cognitive development of pupils around the vmbo-mbo transition]. Groningen, The Netherlands: GION onderzoek/onderwijs.