

University of Groningen

Modifications of center-surround, spot detection and dot-pattern selective operators

Petkov, Nicolai; Visser, Wicher T.

IMPORTANT NOTE: You are advised to consult the publisher's version (publisher's PDF) if you wish to cite from it. Please check the document version below.

Document Version

Publisher's PDF, also known as Version of record

Publication date:

2005

[Link to publication in University of Groningen/UMCG research database](#)

Citation for published version (APA):

Petkov, N., & Visser, W. T. (2005). *Modifications of center-surround, spot detection and dot-pattern selective operators*. University of Groningen, Johann Bernoulli Institute for Mathematics and Computer Science.

Copyright

Other than for strictly personal use, it is not permitted to download or to forward/distribute the text or part of it without the consent of the author(s) and/or copyright holder(s), unless the work is under an open content license (like Creative Commons).

The publication may also be distributed here under the terms of Article 25fa of the Dutch Copyright Act, indicated by the "Taverne" license. More information can be found on the University of Groningen website: <https://www.rug.nl/library/open-access/self-archiving-pure/taverne-amendment>.

Take-down policy

If you believe that this document breaches copyright please contact us providing details, and we will remove access to the work immediately and investigate your claim.

Downloaded from the University of Groningen/UMCG research database (Pure): <http://www.rug.nl/research/portal>. For technical reasons the number of authors shown on this cover page is limited to 10 maximum.

Modifications of center-surround, spot detection and dot-pattern selective operators

Technical report 2005-9-01 (20 January 2005)

Nicolai Petkov and Wicher T. Visser

Institute of Mathematics and Computing Science, University of Groningen
P.O. Box 800, 9700 AV Groningen, The Netherlands
petkov@cs.rug.nl

Abstract— This paper describes modifications of the models of center-surround and dot-pattern selective cells proposed previously by Kruizinga and Petkov. These modifications concern mainly the normalization of the difference of Gaussians (DoG) function used to model center-surround receptive fields, the normalization of center-surround cell responses for average local intensity, the way in which contiguous activity regions in the center-surround cell responses are reduced to single pixels to detect spots and eliminate responses to non-spot features, the way in which groups of spots are detected and the type of output. These modifications are used in the internet implementation of the mentioned models and corresponding biologically motivated image processing operators available at <http://matlabserver.cs.rug.nl>.

Keywords— center-surround cell, difference of Gaussian functions, DoG, dot, feature, group, image processing, lateral inhibition, spot, texture

I. INTRODUCTION

A model of a dot-pattern selective cell and a corresponding image processing operator that is selective for texture made up of dots or spots were proposed in [1]. In the course of re-implementing this model for use via the internet¹, we found certain modifications of the original model necessary. These modifications are described below. The sections and subsections of this paper follow the processing steps of the model. A model of a center-surround cell makes part of the model of a dot-pattern selective cell and some of the modifications concern that part. The detection of intensity spots is another intermediate step that can be used as an image processing operator on its own. For details and references concerning center-surround and dot-pattern selective cells we refer to [1].

II. CENTER-SURROUND CELL RESPONSES

The first step in the model of a dot-pattern selective cell according to [1] is computation of the responses of center-surround cells to an input stimulus (image). Such cells would respond strongly to intensity spots (intensity increments or decrements) of appropriate size and thus act as spot detectors. The responses of these spot detectors can then be used to detect groups (patterns) of spots or dots.

A. Convolution with a DoG

A.1 DoG normalization

A difference of (two) Gaussian (DoG) functions is used in [1] to model the spatial summation properties of a center-surround cell, whereby each of the two Gaussian functions involved is normalized to have an integral of value 1. The modified DoG we propose here has the following form ($\gamma < 1$):

$$DoG_{\sigma,\gamma}(x,y) = \frac{A_c}{\gamma^2} \exp^{-\frac{x^2+y^2}{2\gamma^2\sigma^2}} - A_s \exp^{-\frac{x^2+y^2}{2\sigma^2}} . \quad (1)$$

We select the values of the coefficients A_c and A_s in such a way that all positive values of $DoG_{\sigma,\gamma}$ sum up to 1 and all negative values sum up to -1:

$$\iint [DoG_{\sigma,\gamma}(x,y)]^+ dx dy = 1 , \quad (2)$$

$$\iint [DoG_{\sigma,\gamma}(x,y)]^- dx dy = -1 , \quad (3)$$

where $[w]^+ = \max(0, w)$ and $[w]^- = \min(0, w)$ are a positive and a negative half-wave rectification function, respectively.

The modified normalization (2-3) is motivated by the fact that for large values of γ (near 1) the two Gaussian functions in the originally used² DoG take almost equal values, so that that DoG takes very small values everywhere. The convolution of of an input image with such a DoG would lead to very small responses. In contrast, the modified normalization leads to response values that are in the same range as the intensity increments and decrements in the input image.

In the infinite continuous case of eqs. 2 and 3, the values of the coefficients A_c and A_s are equal. In practice, however, eq.1 is used to initialize a finite discrete filter kernel of a certain size and the integration range in eqs. 2 and 3 is restricted to the area of that size. In that case, the coefficients A_c and A_s need not have equal values and these values are evaluated numerically to satisfy eqs. 2 and 3.

²The normalization used in [1] corresponds to $A_c = A_s = \frac{1}{2\pi\sigma^2}$ in eq.1 and in general does not satisfy eqs. 2 and 3.

¹A simulation program is available at <http://matlabserver.cs.rug.nl>.

A.2 Variable center/surround size ratio

In [1] a fixed value $\gamma = 0.5$ of the ratio between the standard deviation of the center Gaussian (first term in eq.1) and the standard deviation of the surround Gaussian (second term in eq.1) of a DoG was used. In that case, the radius r of the zero crossing at which the function $DoG_{\sigma,\gamma}$ changes polarity, called the center radius, is related to the standard deviation σ of the surround Gaussian as follows: $r = 0.96\sigma$.

Our next modification concerns a generalization of the relation between r and σ in the general case of any value of γ ($0 < \gamma < 1$). The following relation between r , σ and γ can be derived from the equation $DoG_{\sigma,\gamma} = 0$:

$$r = \gamma\sigma\sqrt{\frac{2\ln(A_c/A_s) - 4\ln\gamma}{1 - \gamma^2}}. \quad (4)$$

While in the infinite continuous case the coefficients A_c and A_s are equal, in the finite discrete case their values are still very similar, so that the above equation can be simplified as follows:

$$r \approx 2\gamma\sigma\sqrt{\frac{-\ln\gamma}{1 - \gamma^2}}. \quad (5)$$

In practice, we use the center radius r and the center/surround size ratio γ as free parameters to be selected by the user in computer simulations of center-surround cell responses and compute the value of σ to be used as follows:

$$\sigma \approx \frac{r}{2\gamma}\sqrt{\frac{1 - \gamma^2}{-\ln\gamma}}. \quad (6)$$

B. Half-wave rectification

Similar to the original model [1], an input image $f(x, y)$ is convolved with the receptive field function $DoG_{\sigma,\gamma}(x, y)$ and the result is half-wave rectified:

$$u_{\sigma,\gamma}(x, y) = [f * DoG_{\sigma,\gamma}]^+. \quad (7)$$

C. Intensity normalization

Next, we apply the following intensity normalization:

$$v_{\sigma,\gamma}(x, y) = \frac{u_{\sigma,\gamma}(x, y)}{Cs_{\sigma_{max}}(x, y) + 1} \quad (8)$$

that is different from the contrast normalization used in [1]. C is a positive coefficient and $s_{\sigma_{max}}(x, y)$ is the local intensity (grey level) average computed by convolving the input image $f(x, y)$ with the Gaussian function $\frac{1}{2\pi\sigma_{max}^2} \exp^{-\frac{x^2+y^2}{2\sigma_{max}^2}}$ with the largest standard deviation σ_{max} among those used³.

³In case that a single receptive field function $DoG_{\sigma,\gamma}$ is used, the function deployed to compute the local average is $\frac{1}{2\pi\sigma^2} \exp^{-\frac{x^2+y^2}{2\sigma^2}}$. In case of multiple receptive field functions, the Gaussian $\frac{1}{2\pi\sigma_{max}^2} \exp^{-\frac{x^2+y^2}{2\sigma_{max}^2}}$ relates to the most extended receptive field function $DoG_{\sigma_{max},\gamma}$ among those used.

The modified normalization according to eq.8 is motivated by the following considerations: In the case $C = 0$ (no intensity normalization), the output $v_{\sigma,\gamma}(x, y)$ is equal to the half-wave rectified convolution result $u_{\sigma,\gamma}(x, y)$ and indicates local intensity differences. If C is different from 0, the local intensity differences are normalized with the average local intensity and the output $v_{\sigma,\gamma}(x, y)$ indicates contrast differences and follows approximately the Weber-Fechner law of perception. The use of one and the same normalization factor across all convolution channels prevents detecting spots in a wrong channel.

III. SPOT DETECTION

An intensity spot in the input image will result in a spot of activity in the center-surround cell response (convolution) image. In the spot detection step such a spot of activity is reduced to a single point that is positioned approximately in the center of the spot. Furthermore, the activity in the center-surround cell response image that is not due to intensity spots but to other features, such as edges, is eliminated. In the original model [1] this was achieved with partial success by a lateral inhibition mechanism. Here we propose two additional mechanisms, namely non-maxima suppression and low response removal that further improve results. A schematic view of the mechanisms involved in the spot detection process is given in Fig.1.

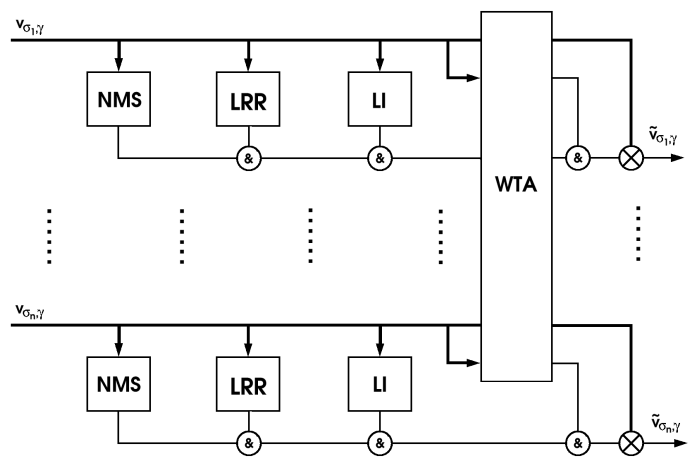

Fig. 1. Schematic view of the spot detection process in which a spot of activity in the center-surround cell response (convolution) image is reduced to a single point that is positioned approximately in the center of the spot.

A. Non-maxima suppression

A non-maxima suppression (NMS) module produces a binary mask $B_{\sigma,\gamma}^{NMS}(x, y)$ that has the value 1 in each point (x, y) in which the center-surround cell response $v_{\sigma,\gamma}(x, y)$ has a local maximum (on a 3×3 neighbourhood) and the

value 0 elsewhere:

$$B_{\sigma,\gamma}^{NMS}(x,y) = \begin{cases} 1 & \text{if } v_{\sigma,\gamma}(x,y) > v_{\sigma,\gamma}(x+i,y+j), \\ & i = -1 \dots 1; \quad j = -1 \dots 1; \\ & (i,j) \neq (0,0) \\ 0 & \text{else} \end{cases} \quad (9)$$

This new mechanism reduces contiguous activity regions to single pixels.

B. Low response removal

A low response removal (LRR) module produces a binary mask $B_{\sigma,\gamma}^{LRR}(x,y)$ as follows:

$$B_{\sigma,\gamma}^{LRR}(x,y) = \begin{cases} 1 & \text{if } v_{\sigma,\gamma}(x,y) > t_{LRR}M_{\sigma,\gamma} \\ 0 & \text{else,} \end{cases} \quad (10)$$

where t_{LRR} , $0 < t_{LRR} < 1$, is a coefficient that we call the low response removal threshold and

$$M_{\sigma,\gamma} = \max\{v_{\sigma,\gamma}(x,y) \mid \forall(x,y)\}. \quad (11)$$

is the maximum center-surround response for the considered convolution channel. This mechanism is used to eliminate low responses.

C. Lateral inhibition

Similar to the original model according to [1], a lateral inhibition (LI) module produces a binary mask $B_{\sigma,\gamma}^{LI}(x,y)$ as follows:

$$B_{\sigma,\gamma}^{LI}(x,y) = \begin{cases} 1 & \text{if } \rho v_{\sigma,\gamma}(x,y) > v_{\sigma,\gamma}(x',y') \\ & \forall(x',y') : \|(x',y') - (x,y)\|_2 = R_{LI} \\ 0 & \text{else,} \end{cases} \quad (12)$$

where ρ , $0 < \rho < 1$, is a coefficient that we call the lateral inhibition response ratio and R_{LI} is a distance parameter that we call the lateral inhibition distance. To compute $B_{\sigma,\gamma}^{LI}(x,y)$, the response $v_{\sigma,\gamma}(x,y)$ in a position (x,y) is compared with the responses $v_{\sigma,\gamma}(x',y')$ in a number of neighbouring positions (x',y') at a distance R_{LI} from (x,y) . In practice, not all but only a fixed number N_{LI} of positions (x',y') that lie on a circle of radius R_{LI} centered at (x,y) are probed. In [1] R_{LI} (denoted there by R_{lat}) was chosen as follows $R_{LI} = 1.36\sigma$. As a minor modification to the original model, here we make the following choice for R_{LI} :

$$R_{LI} = r, \quad (13)$$

where r is the radius of the center of $DoG_{\sigma,\gamma}(x,y)$. Reasonable results are obtained for $\rho = 0.5$ and $N_{LI} = 10$. The values of ρ and N_{LI} are related: larger values of N_{LI} should be taken for larger values of ρ in order to achieve effective lateral inhibition.

D. Winner-takes-all competition

The winner-takes-all competition (WTA) module used in [1] is not changed. This module is used in case that multiple convolution channels (with different kernel radii)

are employed. It produces a binary mask for each channel. The value of the binary mask of a given channel at position (x,y) is set to 1 if the center-surround cell response $v_{\sigma,\gamma}(x,y)$ at that point is larger than the center-surround cell responses at the same point for all other channels used. Otherwise, the value of the mask is set to 0. More specifically, a binary mask $B_{\sigma,\gamma}^{WTA}(x,y)$ is computed follows:

$$B_{\sigma,\gamma}^{WTA}(x,y) = \begin{cases} 1 & \text{if } \forall\sigma' \neq \sigma \quad v_{\sigma,\gamma}(x,y) > v_{\sigma',\gamma}(x,y) \\ 0 & \text{else.} \end{cases} \quad (14)$$

E. Spot detection output

The binary masks produced for a given channel by the NMS, LRR, LI and WTA modules are combined by pixel-wise multiplication and the resulting binary mask $B_{\sigma,\gamma}(x,y)$ specifies the positions at which spots (of a radius corresponding to that channel) are centered:

$$B_{\sigma,\gamma}(x,y) = B_{\sigma,\gamma}^{NMS}(x,y)B_{\sigma,\gamma}^{LRR}(x,y)B_{\sigma,\gamma}^{LI}(x,y)B_{\sigma,\gamma}^{WTA}(x,y). \quad (15)$$

The output $\tilde{v}_{\sigma,\gamma}(x,y)$ of the spot detection step at image positions for which this mask takes the value 1 is equal to the corresponding center-surround cell response $v_{\sigma,\gamma}(x,y)$; in all other positions the output $\tilde{v}_{\sigma,\gamma}(x,y)$ is 0:

$$\tilde{v}_{\sigma,\gamma}(x,y) = B_{\sigma,\gamma}(x,y)v_{\sigma,\gamma}(x,y). \quad (16)$$

IV. SPOT-GROUP DETECTION

In this step groups of spots are detected. The input to this step is the output $\tilde{v}_{\sigma,\gamma}(x,y)$ of the previous, spot detection step. The output $t_{\sigma,\gamma}(x,y)$ of the spot-group detection in a given point will be different from 0 only if a certain minimum number m of spots responses of a given minimum strength θ are found in a certain surroundings of the point:

$$t_{\sigma,\gamma}(x,y) = \begin{cases} 1 & \text{if } \text{card}\{(x',y') \mid \tilde{v}_{\sigma,\gamma}(x',y') > \theta, \\ & \forall(x',y') : |x' - x| < \zeta r, |y' - y| < \zeta r\} > m \\ 0 & \text{else.} \end{cases} \quad (17)$$

A modification of the original model according to [1] is that the surroundings of a point that is examined for presence of spot responses is a square window vs. circular one in the original model. The side of this window is $2\zeta r$ where ζ is a parameter used to specify the window side in units of the diameter $2r$ of the spots that are counted in the window. Another modification is that all points in the considered surroundings are taken into account whereas in the original model only a given number of such points are selected at random. One further modification is that instead of the binary output according to eq.17 the user can choose for density type output:

$$t_{\sigma,\gamma}(x,y) = \begin{cases} \text{card}\{(x',y') \mid \tilde{v}_{\sigma,\gamma}(x',y') > \theta, \forall(x',y') : \\ & |x' - x| < \zeta r, |y' - y| < \zeta r\} / (2\zeta r)^2 \\ \text{if } \text{card}\{(x',y') \mid \tilde{v}_{\sigma,\gamma}(x',y') > \theta, \\ & \forall(x',y') : |x' - x| < \zeta r, |y' - y| < \zeta r\} > m \\ 0 & \text{else.} \end{cases} \quad (18)$$

V. RESPONSE SMOOTHING

The next, final stage of the model of a dot-pattern selective neuron according to [1] is unchanged and is given here for completeness. In this stage the response $b_{\sigma,\gamma,\beta}(x,y)$ of a dot-pattern selective neuron is computed by a weighted summation of the responses of spot-group subunits by means of convolution with a Gaussian function $G_{\sqrt{\beta}\sigma}(x,y)$ with a standard deviation $\sqrt{\beta}\sigma$ ($\beta > 1$):

$$b_{\sigma,\gamma,\beta}(x,y) = G_{\sqrt{\beta}\sigma} * t_{\sigma,\gamma}. \quad (19)$$

The parameter β specifies, roughly speaking, the receptive field size of a dot-pattern selective neuron in terms of a number of center-surround fields. (In [1], $\beta = 8$ is used.)

VI. SUMMARY

In this paper we proposed the following modifications to the model of a dot-pattern selective cell described in [1]:

A. Center-surround cell responses

- The DoG filter kernel is normalized in such a way that all its positive values sum up to 1 and all negative values sum up to -1.
- A general relation between the radius r of the center of a center-surround receptive field function $DoG_{\sigma,\gamma}$ and the parameters σ and γ is derived.
- A different contrast normalization is proposed in which the same average intensity normalization factor is used across all channels.

B. Spot detection

- Non-maxima suppression mechanism is added to the spot detection step in order to reduce contiguous activity regions to single pixels.
- A low response removal mechanism is added to the spot detection step.
- The distance at which lateral inhibition acts is taken to be equal to the radius of the center of the DoG function used.
- The output of the spot detection step for a given convolution channel is a product of the corresponding center-surround cell response image and the binary masks computed by the NMS, LRR, LI and WTA modules.

C. Spot-group detection

- The surroundings of a point that is examined for presence of spot responses is a square window vs. circular one in the original model.
- All points in the considered surroundings are taken into account whereas in the original model only a given number of such points are selected at random.
- Next to a binary type output according to the original model, a density type of output can be selected.

D. Response smoothing

- While the type of processing (weighted averaging of spot-group detection responses) remains the same as in the original model, the type of input to this stage can be selected

between binary or density by setting the type of output of the previous spot-detection step.

REFERENCES

- [1] P. Kruizinga and N. Petkov, "Computational model of dot-pattern selective cells," *Biological Cybernetics*, vol. 83, no. 4, pp. 313–325, 2000.