

ABSTRACT

Title of Document: VALIDATING A THEORY-BASED MODEL OF L2 READING COMPREHENSION: RELATIVE CONTRIBUTIONS OF CONTENT-SPECIFIC SCHEMATIC KNOWLEDGE AND L2 VOCABULARY KNOWLEDGE TO COMPREHENDING A SCIENCE TEXT

Eunjou Oh, Ph.D., 2010

Directed By: Professor Peter Afflerbach, Department of Curriculum and Instruction
Professor Robert Mislevy, Department of Measurement, Statistics, and Evaluation

The study explores the question of what explains second language (L2) reading comprehension by proposing a comprehensive theory building on the Construction Integration (CI) model of reading comprehension (Kintsch, 1998) and conducting an experimental study within this theoretical framework. The proposed theory maintains that the construction of a *textbase* is a function of L2 proficiency and the construction of a *situation model* is a function of first language (L1) reading competence. The effect of two different types of intervention tapping into each representation system (*textbase* and *situation model*) is experimentally tested; vocabulary knowledge, conducive to building *textbase*, and content-specific schematic knowledge, facilitative to building *situation model*. Two different measures of reading comprehension for

both L1 and L2 reading comprehension are used to analyze how different cognitive processes are involved in L2 reading comprehension. Thirty two 9th grade Korean students were given a vocabulary acquisition activity and a content-specific schematic knowledge acquisition activity between a pretest and a posttest on science texts. The findings suggest that the ability to form macropropositions, as measured by a recall task, is a route through which L1 reading competence emerges. Thus, it is an influential factor for L2 reading comprehension. Different patterns in the role of L1 reading competence and L2 proficiency in different treatment conditions provide evidence for a reader constructing a *textbase* as a function of L2 proficiency and a reader constructing a *situation model* as a function of L1 reading competence. Three latent variables of *textbase*, *situation model*, and L2 reading comprehension were entered in LISREL to conduct structural equation modeling; the indicators of the *textbase* include the scores of vocabulary knowledge and the scores of listening comprehension (LC) and reading comprehension (RC) in an L2 proficiency measure; the indicators of the *situation model* include the scores of L1 reading competence and the scores of schematic knowledge; and the indicators of L2 reading comprehension include the scores of the pretests and the posttests. The fit indices of various Structural Equation Modeling (SEM) models of a given text demonstrate the viability of the comprehensive theory of L2 reading comprehension.

VALIDATING A THEORY-BASED MODEL OF L2 READING
COMPREHENSION: RELATIVE CONTRIBUTIONS OF CONTENT-SPECIFIC
SCHEMATIC KNOWLEDGE AND L2 VOCABULARY KNOWLEDGE TO
COMPREHENDING A SCIENCE TEXT.

By

Eunjou Oh

Dissertation submitted to the Faculty of the Graduate School of the
University of Maryland, College Park, in partial fulfillment
of the requirements for the degree of
Doctor of Philosophy
2010

Advisory Committee:
Professor Peter Afflerbach, Co-Chair
Professor Robert Mislevy, Co-Chair
Professor Robert DeKeyser
Professor Mariam Jean Dreher
Professor Bruce VanSledright

© Copyright by
Eunjou Oh
2010

Table of Contents

List of Tables iv

List of Figures vi

Chapter 1: Introduction		1
1.1 Organization of the Paper		1
1.2 Statement of Problem		7
1.3 Purpose of the Study		15
Chapter 2: Literature Review		19
2.1 Review of L1 Reading Comprehension.....		20
2.2 Review of L2 Reading Comprehension.....		23
2.3 The Construction Integration Model by Kintsch (1998)		26
2.3.1 General Construct		26
2.3.2 The Construction Integration Model for L2 Reading Comprehension		37
2.3.3 Role of Memory in the CI Model: Long-term Memory (LTM), Long-term Working Memory (LT-WM) and Working Memory (WM)		41
2.4 Role of Memory in Reading Comprehension		45
2.4.1 General Construct of Working Memory (WM)		45
2.4.2 Working Memory (WM) and L1 and L2 Reading		50
2.4.3 Episodic Buffer and Long-Term Working Memory (LT-WM).....		56
2.5 Theory for Instruction: Cognitive Load Theory (CLT)		70
2.6 The Foci of the Study		74
2.6.1 Cognitive Load Theory (CLT) and Advance Organizer		74
2.6.2 Vocabulary Knowledge and Schematic Knowledge		78
2.6.3 Relationship Between L1 Reading Competence and L2 Proficiency		82
2.7 Hypotheses Drawn from the Literature Review		85
Chapter 3: Method		93
3.1 Participants		93
3.2 Reading Text		97
3.3 Treatment		98
3.4 Instrument		100
3.5 Procedures		105
Chapter 4: Results		111
4.1 Scoring Procedure		112
4.2 Hypothesis 1		115
4.3 Hypothesis 2		119
4.4 Hypothesis 3		121
4.5 Hypothesis 4.....		126
4.6 Hypothesis 5		132

Chapter 5: Discussion		142
5.1 Hypothesis 1: Treatment Effect		142
5.2 Hypothesis 2: Associations of Variables (L2 proficiency, L1 reading competence, vocabulary knowledge acquisition, and schematic knowledge acquisition)		144
5.3 Hypothesis 3: Test of the Linguistic Threshold Hypothesis		144
5.4 Hypothesis 4: Effect of Different Kinds of Knowledge		155
5.5 Hypothesis 5: Fit Indices		165
5.6 Summary of the Hypotheses		166
Chapter 6: Conclusion		173
6.1 How the findings of the study address the purpose of the study		173
6.2 Implications		179
6.2.1 Theoretical Implications		179
6.2.2 Pedagogical Implications		181
6.2.3 Assessment Implications		185
6.3 Limitations of the Study		185
6.4 Future Directions		187
	Appendices	190
	Glossary	233
	Bibliography	236

List of Tables

- Table 1 Summary of the studies on the relationships among L1 reading competence, L2 linguistic knowledge and L2 reading comprehension
- Table 2.1 Memory in relation to L1 and L2 reading
- Table 2.2 Summary of major studies in working memory and reading
- Table 3.1 Administration of procedures
- Table 3.2 Learning standards of English reading for 9th graders in Korea
- Table 4.1 Terms for different measures
- Table 4.2 Descriptive statistics for treatment groups
- Table 4.3 Descriptive statistics for the control group
- Table 4.4 Paired sample correlations of the pretests and posttests (Control group)
- Table 4.5 Paired sample correlations of the pretests and posttests (Vocabulary knowledge acquisition group)
- Table 4.6 Paired sample correlations of the pretests and posttests (Schematic knowledge acquisition group)
- Table 4.7 Paired samples t tests (Control group)
- Table 4.8 Paired samples t tests (Vocabulary knowledge acquisition group)
- Table 4.9 Paired samples t tests (Schematic knowledge acquisition group)
- Table 4.10 Relative contributions of predictor variables to different L2 reading comprehension measures in different treatment conditions
- Table 4.11 Relative contributions of L1 reading competence to different L2 reading comprehension measures in different treatment conditions

Table 4.12 Relative contributions of L1 reading competence to L2 proficiency (the scores of TOEIC Bridge) in different treatment conditions

Table 4.13 Goodness of fit of the CI model with different L2 comprehension measures

List of Figures

- Figure 1.1 An initial cycle of the comprehension process
- Figure 1.2 A subsequent cycle of the comprehension process
- Figure 1.3 Detecting a comprehension problem and acting on it
- Figure 1.4 Consequences of the reading problem-fixing action
- Figure 4.1 Change of comprehension between the pretests and the posttests in three conditions
- Figure 4.2 Relative contributions of L1 and L2 to the vocabulary knowledge
- Figure 4.3 Relative contributions of L1 and L2 to the schematic knowledge
- Figure 4.4 L1MC (Korean reading comprehension measured by multiple-choice and T/F questions) with L2 CompMC (English reading comprehension measured by multiple-choice and T/F questions) in the pretest conditions
- Figure 4.5 L1MC (Korean reading comprehension measured by multiple-choice and T/F questions) L2CompRec (English reading comprehension measured by a recall task) in the pretest conditions
- Figure 4.6 L1Rec (Korean reading comprehension measured by a recall task) with L2CompMC (English reading comprehension measured by multiple-choice and T/F questions) in the pretest conditions
- Figure 4.7 L1Rec (Korean reading comprehension measured by a recall task) with L2CompRec (English reading comprehension measured by a recall task) in the pretest conditions
- Figure 4.8.1 L1MC (Korean reading comprehension measured by multiple-choice and T/F questions) with L2 CompMC (English reading comprehension

measured by multiple-choice and T/F questions) in the vocabulary knowledge acquisition condition

Figure 4.8.2 L1MC (Korean reading comprehension measured by multiple-choice and T/F questions) L2CompRec (English reading comprehension measured by a recall task) in the vocabulary knowledge acquisition condition

Figure 4.8.3 L1Rec (Korean reading comprehension measured by a recall task) with L2CompMC (English reading comprehension measured by multiple-choice and T/F questions) in the vocabulary knowledge acquisition condition

Figure 4.8.4 L1Rec (Korean reading comprehension measured by a recall task) with L2CompRec (English reading comprehension measured by a recall task) in the vocabulary knowledge acquisition condition

Figure 4.9.1 L1MC (Korean reading comprehension measured by multiple-choice and T/F questions) with L2 CompMC (English reading comprehension measured by multiple-choice and T/F questions) in the schematic knowledge acquisition condition

Figure 4.9.2 L1MC (Korean reading comprehension measured by multiple-choice and T/F questions) L2CompRec (English reading comprehension measured by a recall task) in the schematic knowledge acquisition condition

Figure 4.9.3 L1Rec (Korean reading comprehension measured by a recall task) with L2CompMC (English reading comprehension measured by multiple-choice and T/F questions) in the schematic knowledge acquisition condition

Figure 4.9.4 L1Rec (Korean reading comprehension measured by a recall task) with
L2CompRec (English reading comprehension measured by a recall task)
in the schematic knowledge acquisition condition

Figure 4.10 Measurement model of Construction Integration Model for L2 reading
comprehension

Figure 4.11 Construction Integration Model for L2 reading comprehension –
PreL2CompMC (English reading comprehension measured by multiple-
choice and T/F questions in the pretests)

Figure 4.12 Construction Integration Model for L2 reading comprehension –
PreL2CompRec (English reading comprehension measured by a recall
task in the pretests)

Figure 4.13 Construction Integration Model for L2 reading comprehension –
PreL2Comp (English reading comprehension measured by multiple-
choice and T/F questions and a recall task in the pretests)

Figure 4.14 Construction Integration Model for L2 reading comprehension –
PostL2CompMC (English reading comprehension measured by multiple-
choice and T/F questions in the posttests)

Figure 4.15 Construction Integration Model for L2 reading comprehension –
PostL2CompRec (English reading comprehension measured by a recall
task in the posttests)

Figure 4.16 Construction Integration Model for L2 reading comprehension –
PostL2Comp (English reading comprehension measured by multiple-
choice and T/F questions and a recall task in the posttests)

Chapter 1: Introduction

The present study is motivated by the recognition that there is no comprehensive theory explaining specific cognitive processes involved in L2 reading comprehension. How the awareness of this problem arises is elaborated in the statement of the problem. In order to address this problem, two purposes of the study are introduced: (1) to propose a comprehensive theory for L2 reading comprehension and (2) to conduct an experimental study that validates constructs extracted from the theory and investigates specific cognitive processes of L1 reading competence, L2 proficiency and L2 reading comprehension. The definitions of important terms used in the paper are provided in the glossary.

1.1 The Organization of the Paper

Chapter One elaborates the statement of the problem and the rationale for conducting the present study. Chapter Two includes the review of L1 reading comprehension, which gives a rationale for the selection of the CI model among contemporary theories on L1 reading comprehension available as of today. The CI model is introduced in detail followed by the extended CI model for L2 reading comprehension. One critical construct involved in various cognitive processes specified by the CI model is three types of memory; long-term memory (LTM), long-term working memory (LT-WM), and working memory (WM). The role of memory in the CI model will be discussed, followed by a general review on working memory;

the multi-component model by Baddeley and Hitch (1974) will be discussed in relation to reading in detail.

To explain how the design of the proposed study accommodates memory load at a readers' manageable level, Cognitive Load Theory (CLT) is introduced; CLT is the theory that suggests designing instruction based on an analysis of cognitive load involved in certain materials and activities. One particular design to be used as a form of treatment is an advance organizer. Since a task of L2 reading comprehension demands linguistically and informationally high cognitive load on readers, distributing such load into a two-step process is a desirable approach according to CLT. Thus, how an advance organizer can be facilitative to processing cognitively overtaxing information is discussed. Different characteristics of two treatment types, vocabulary knowledge acquisition and schematic knowledge acquisition, are elaborated in terms of the foci of the present study. How L1 reading competence and L2 proficiency are related to each other to explain L2 reading comprehension based on the proposed theory is explicated as well.

Five hypotheses drawn from the literature review are addressed. They are as follows:

- (1) The comprehension of L2 reading texts will significantly improve when the intervention of vocabulary knowledge acquisition or schematic knowledge acquisition is provided.
- (2) The effect of L1 reading competence and L2 proficiency will be different in the two treatment conditions.

- (3) The effect of different L1 reading competence upon L2 reading comprehension in the pretests for all conditions (one control and two treatment conditions) will be minimal due to the linguistic threshold or bottleneck effect.
- (4) There will be different effects of an intervention type upon comprehension, which will be shown in different reading comprehension measures and item types, such as multiple-choice and true/false questions and recall, as well as their related cognitive processes.
- (5) The textbase, or a mental representation of elements and relations directly derived from the text itself, (indicators include L2 proficiency and vocabulary knowledge) and the situation model, or the propositions elaborated by background knowledge, (indicators include L1 reading competence and schematic knowledge) will successfully explain L2 reading comprehension.

Chapter Three provides detailed information on the methods of the present study. The choice of Korean participants was made on the basis of logistic reasons; access to public schools in the U.S. for research is extremely difficult compared to Korean participants who volunteered to participate in the study over the summer vacation (how participants were recruited is explained in the Method section in detail). Choosing adolescent students was of prime interest because they are one of the groups that have least been studied for L2 reading comprehension and are at the stage of developing high level thinking skills along with L2 linguistic knowledge. Science text is selected because it imposes relatively less linguistic or verbal demands on readers but instead carries more condensed conceptual knowledge as opposed to history texts or language art texts. This particular feature is relevant to investigating

the questions raised in the present study; how schematic knowledge can affect L2 reading comprehension. In order to measure L2 proficiency, a standardized test (TOEIC, test of English for international communication, Bridge) that consists of listening comprehension and reading comprehension is used. This was intended to represent L2 proficiency more accurately. Two kinds of reading comprehension measures (multiple-choice and true/false questions and a recall task) allow finer-grained levels of analysis in both L1 reading comprehension and L2 reading comprehension. To analyze this complex design, Structural Equation Modeling (SEM) was used because it can operationalize latent constructs such as L1 reading competence, L2 proficiency, and L2 reading comprehension with specified indicators and the path among such latent variables. Above all, it makes it possible to analyze different combinations of variables as latent variables, which allows us to investigate the multidimensionality of the latent construct L2 reading comprehension.

The analyses of the results showed that both vocabulary and schematic knowledge acquisition activities facilitate statistically significant improvement in two measures (multiple-choice questions and recall) of L2 reading comprehension, whereas there was no significant change in either of L2 reading comprehension in the control group (the confirmation of the hypothesis 1). It is shown that L1 reading competence is a significant predictor for the acquisition of schematic knowledge, while L2 proficiency is a significant predictor for the acquisition of vocabulary knowledge (the confirmation of the hypothesis 2). The Linguistic Threshold Hypothesis (Cummins, 1979) is partially confirmed in the pretest conditions (the partial confirmation of the hypothesis 3). Since the scores of multiple-choice

questions showed no significant effect of L1 reading competence regardless of the measurement form (L2 reading comprehension measured by multiple-choice and true/false questions and a recall task), and the scores of the recall task had no significant effect on L2 reading comprehension measured by multiple-choice and true/false questions, it is deemed that the effect of linguistic threshold or bottleneck effect was held strong in these three models. However, since the scores of the L1 recall task were a significant predictor for L2 reading comprehension measured by the recall task, the Linguistic Interdependency Hypothesis is manifested in this model. Thus, the third hypothesis that tested the Linguistic Threshold Hypothesis is partially confirmed.

Concerning the treatment effects, L1 reading competence and L2 proficiency differentially contribute to L2 reading comprehension over a different treatment and different measures of comprehension (the confirmation of hypothesis 4). Interpreted within the proposed theory of L2 reading comprehension, the findings validate different levels of mental representations taxed during on-line L2 reading comprehension. Textbase, which gets enhanced by the vocabulary knowledge intervention from the impoverished textbase due to the lack of L2 proficiency in the pretest, decreased the dependence on L2 proficiency in all types of measures after the vocabulary knowledge intervention. However, the constructed textbase, which stays more or less impoverished after the schematic knowledge acquisition activity, but the elaborated situation model due to the intervention, increased the dependence on L2 proficiency in L2 reading comprehension measured by the multiple-choice and true/false questions but decreased the dependence on L2 proficiency in L2 reading

comprehension measured by the recall task. As to the L1 reading competence, no significant role of L1 reading competence measured by multiple-choice and true/false questions in the pretests remained the same in the posttest of both treatment conditions. However, the role of L1 reading competence measured by the recall task increased in explaining L2 reading comprehension measured by the recall task in both treatment conditions.

The results show how different representation systems (a textbase and a situation model) are connected to vocabulary knowledge and schematic knowledge respectively, and how L1 reading competence and L2 proficiency come into play in these processes. They also serve as evidence that textbase as a function of L2 proficiency and situation model as a function of L1 reading competence are indeed distinctive constructs, and each contributes to L2 reading comprehension. The CI model for L2 reading comprehension, when operationalized with the proposed indicators to represent the textbase and the situation model for L2 reading comprehension, was partially confirmed by the collected data in that not all the model fit indices showed good model fit, even though the meaning of the values in each fit index needs to be elaborated in relation to what comes to the foreground in each index (partial confirmation of hypothesis 5).

The findings summarized above are elaborated in detail in Chapter Five of the discussion section. Of the most interesting findings is that what is measured by the recall task explains cognitive processes that show the impact of L1 reading competence on L2 reading comprehension. Thus, it provides some answer to the question raised by Koda (2007), “how the transferred competencies, shaped in one

language, become functional in another (p. 30).” Chapter Six, the conclusion lays out the major findings of the study in terms of their significance to the field of L2 reading research. Implications, future directions and limitations are also discussed.

1.2 Statement of the Problem

The question of what cognitive processes account for first language (L1) reading has been explored in many different ways (Rosenblatt, 1938; Anderson & Pearson, 1984; Palincsar & Brown, 1984; Graesser & Kreuz, 1993; van den Broek, 1993; Pressley & Afflerbach, 1995; Kintsch, 1998). When it comes to second language (L2) reading, the question becomes even more complicated because the whole process of reading comprehension gets confounded with L2 language proficiency (Roebuck, 1998; Bernhardt, 2005; Koda, 2007). The relationships among L1 reading competence, L2 proficiency and L2 reading comprehension have been a focus of investigation among educators, L2 researchers, and test designers. Educators, who have often observed children with stronger L1 literacy skills become successful readers in L2, argue that second language reading can be better explained by individual differences in their L1 literacy skills, which led them to advocate for bilingual education. L2 researchers have also been interested in the degree to which linguistic knowledge as opposed to L1 reading competence or general cognitive abilities impacts L2 reading comprehension. Language test developers who need to ensure the construct validity of tests – whether what a test measures what it claims to measure – are another group of people who are interested in the interactions of L1 reading competence, L2 proficiency and L2 reading comprehension.

The relationship among L1 reading competence, L2 proficiency and L2 reading comprehension has been investigated in the context of two hypotheses, the Linguistic Threshold Hypothesis (Cummins, 1979) and the Linguistic Interdependence Hypothesis (Cummins, 1981). The former posits that the transfer of one's first language reading skills to the foreign language takes place only when one has reached a threshold level of competence in the target language (L2), whereas the latter holds that one's experience with literacy operation and constructs in either their L1 or L2 can be conducive to the development of literacy skills underlying both languages. Even though the studies conducted under these hypotheses (Carrell, 1991; Bossers, 1991; Bernhardt and Kamil, 1995; Brisbois, 1995) informed us of the general pattern of how the roles of L1 reading competence and L2 proficiency change at different L2 proficiency levels, the constructs of L1 reading competence and L2 proficiency were represented by aggregated scores of multiple-choice questions (Koda, 2007). For this reason, the interpretation of such scores is unidimensional, which does not allow fine-grained levels of analysis of different cognitive processes. In order to reflect multidimensional aspects of L1 reading competence, L2 proficiency, and L2 reading comprehension, it becomes necessary to use a solid theoretical model that identifies various cognitive processes involved in each construct and a statistical method that incorporates the multidimensionality of different cognitive constructs.

Despite the limitations of the studies, what they found is worth mentioning. Thus, the summary of the four studies (Carrell, 1991; Bossers, 1991; Bernhardt and Kamil, 1995; Brisbois, 1995) that have been designed specifically to address two

hypotheses is given and followed by the critique on them. Carrell (1991) compared two groups of L2 learners; Group 1 consisted of 45 native speakers of Spanish, whose proficiency was divided into three (intermediate ESL students in college, advanced intensive ESL in college, and those who were already accepted in the U.S. college with the sample sizes for each level, 8, 20, and 17 respectively) and Group 2 consisted of 75 native speakers of English who had been taking Spanish classes for one, two, and three years in college (the sample sizes for each level, 39, 23, and 13 respectively). Multiple choice questions about two reading passages with comparable contents and the same rhetorical formats (a problem/solution and a compare/contrast) were given to each group of students. The analysis of the General Linear Models, regression procedures and *post hoc* multiple regression showed that both of the L2 proficiency and L1 reading were significant contributors to L2 reading (39.7% of the total variance). However, an interesting pattern was that L1 reading was a stronger predictor than L2 proficiency for Group 1, whereas the pattern was reversed for Group 2. Carrell attributed this pattern to several potential sources such as different contexts (the target language for group 1 was a second language, whereas the target language for group 2 was a foreign language), the differences in absolute level of proficiency, or potential differences in directionality of the learning (English as a native language to Spanish as a target language or Spanish as a native language to English as a target language).

Bossers (1991) tested 50 adult native Turkish speakers learning Dutch as a second language. He collected data on their levels of L1 and L2 reading and L2 linguistic knowledge; he used multiple-choice questions about reading passages for

L1 and L2 reading comprehension that had been manipulated to match text structure, syntactic complexity, length, and the number of propositions among them. L2 linguistics knowledge was measured via Dutch-as-a-second-language test battery (Janssen-van Dielen, 1988), one that included vocabulary knowledge and grammar knowledge. The regression analyses showed that L1 reading and L2 knowledge together accounted for 73 % of the total variance of L2 reading – 19% contribution of L1 reading and 54% contribution of L2 proficiency respectively, confirming the fact that these two variables are most influential variables for L2 reading. In the following post hoc analysis, he found out that the 35 least skilled L2 readers and the 15 most skilled readers had different patterns. The 35 less skilled group had significant effect of L2 knowledge on L2 reading but not on L1 reading, whereas 15 more skilled readers had L1 reading as the only significant predictor for L2 reading. The results can be interpreted in such a way that they support both of the hypotheses. The less skilled group was confined to linguistic threshold that they could not make use of their L1 resources for L2 reading comprehension while the skilled group staying above and beyond this linguistic threshold made full use of their L1 resources transferred to L2 reading comprehension, which became a strong predictor for L2 reading.

Bernhardt and Kamil (1995) also investigated the same question with 167 adult native English speakers learning Spanish. They gave two English reading tests and one Spanish reading test to three different Spanish proficiency groups of learners (the sample size for each level is 124 for the level one, 21 for the level two, and 22 for the level three). The multiple regression analysis on the scores of each measure

indicated that L1 reading accounted for between 10% and 16% of the variance of L2 reading, whereas L2 proficiency indicated by the three levels of classes accounted for between 30% and 38%. They concluded that “while language proficiency accounts for a greater proportion of the variance, first language reading also makes a significant contribution” (p. 25). Using 88 beginners and 43 upper level students who enrolled in French at the U.S. Air Force Academy, Brisbois (1995) found that all of the independent variables – L1 reading measured by multiple choice and recall items, L2 linguistic knowledge measured by the size of L2 vocabulary and knowledge in L2 grammar – contributed significantly to L2 reading comprehension for beginners. This corroborated the finding by Bernhardt and Kamil (1995) who showed L2 proficiency as a stronger predictor with still significant contribution of L1 transfer to L2 reading. For the upper level students, L1 reading scores (recall) contributed nearly twice the variance (20.50%) as it did for beginners (11.09%).

All of the studies investigated the same question, the role of L1 reading competence and L2 linguistic knowledge on L2 reading comprehension and used the same multiple regression analysis to identify the contribution of each variable to L2 reading. From these studies emerges a consistent pattern: (1) the role of L2 proficiency plays a more critical role in the beginning stage of L2 reading, corroborating the Linguistic Threshold Hypothesis (Cummins, 1979); and (2) L1 reading becomes a stronger predictor for L2 reading at a more advanced level, which supports the Linguistic Interdependency Hypothesis (Cummins, 1981). Generally speaking, the finding may influence the design of effective pedagogical approaches to L2 reading comprehension; linguistically focused curriculum is designed for

beginning level students, and the focus is shifted to the curriculum that taps into the utilization of L1 resources to a great degree in later stages of L2 development. In a practical perspective related to diagnostic and placement testing, Brisbois (1995) claimed that students with strong L1 literacy should perhaps be placed in accelerated L2 courses.

However, as Bernhardt and Kamil (1995) suggested in the interpretation of the result, one should be careful to consider the unbalanced group size; all of the studies had a different sample size for different L2 proficiency with considerably more subjects at a beginner level. The measures of L2 proficiency and L2 reading competence employed also raise questions. The studies differed in the measure of L2 linguistic knowledge; for example, Carrell (1991) and Bernhardt and Kamil (1995) used the number of semesters that the students attended in the Spanish programs (different levels), whereas Bossers (1991) and Brisbois (1995) administered separate tests on L2 vocabulary and L2 grammatical skills. How to represent L2 proficiency differed in the studies without appropriate substantive rationales for the choice of each method of representation. The measures used to represent complex cognitive processes are a critical issue in the interpretation of the results in order not to overgeneralize the findings. Yet, the determination of (and argument for) specific measures or indicators is possible only with the presence of a comprehensive theory in L2 reading comprehension. With the guidance of such a theory, the components that explain L2 proficiency and how these components interact among themselves and with L2 reading competence can be examined in a more systematic and thus efficient manner.

In a similar vein, the measures of L1 reading competence need to be elaborated. There is a considerable body of research that explains different abilities in L1 reading. This indicates that L1 reading is not a unidimensional construct but a realization of various interacting abilities and processes such as recognizing surface structure, integrating background knowledge, detecting inconsistency, making inferences, and using strategies. However, all the previously cited studies took L1 reading as one construct that influences L2 reading, which led researchers to use the scores of multiple choice questions in order to account for L1 reading ability; except for Brisbois (1995) who included recall as well as multiple choice questions for L1 reading comprehension, all three studies used multiple choice questions only. The scores of such questions might be informative in terms of interpreting students' abilities in a norm-referenced framework; differentiating abilities within a certain group of students. In this sense, these measures met their needs in those studies. However, such a design does not give much useful information as to what kinds of cognitive processes are involved in L1 reading, what components of such cognitive processes make a strong contribution to L2 reading comprehension, and how these variables interact. Therefore, exactly the same issue as for L2 proficiency – a need for more comprehensive microscopic analysis and a theory – is pertinent to the investigation of the role of L1 reading competence for L2 reading.

In short, explanations of the use of L1 reading competence and L2 proficiency in a broad sense as included in the previous studies need to be refined through the accommodation of more detailed cognitive processes and analysis in relation to a comprehensive theory. Thanks to recent developments with cognitive

Table 1. Summary of the studies on the relationships among L1 reading competence, L2 linguistic knowledge and L2 reading comprehension

	Participants	Measures	Results
Carrell (1991)	. 45 native speakers of Spanish learning English and 75 native speakers of English learning Spanish in college	. Multiple-choice questions on two reading passages in Spanish and English	. Both L2 proficiency and L1 reading were significant contributors to L2 reading (39.7% of the total variance) . L1 reading is a stronger predictor for native Spanish speakers, whereas L2 proficiency was a stronger predictor for native English speakers.
Bossers (1991)	. 50 adult native Turkish speakers learning Dutch as a 2 nd language	. Multiple-choice questions on L1 and L2 reading passages . Dutch as a 2 nd language battery (vocabulary + grammar)	. L1 reading and L2 knowledge accounted for 73% of the total variance (19% of L1 reading and 54% of L2 proficiency). . L2 knowledge was the only significant predictor for less skilled L2 readers, whereas L1 reading was the only significant predictor for skilled L2 readers.
Benhardt and Kamil (1995)	. 167 adult native English speakers learning Spanish	. L1 reading: Nelson-Denny Reading Test (comprehension and rate) & English ABLE (adult basic learning examination, 48 multiple choice questions) . L2 reading: Spanish ABLE tests (48 multiple choice questions)	. While L2 proficiency explained 30%~38% of the variance, L1 reading still accounted for between 10%~16% of the variance of L2 reading, which is a significant contribution.
Brisbois (1995)	. 131 adult English native speakers learning French	. L1 Reading: Nelson-Denny reading test and recall . L2 linguistic knowledge: vocabulary & grammar . L2 reading: free recall protocols	. L1 reading accounted for 20.50% for the upper level of students, whereas L1 reading explained 11.09% for beginning students.

sciences (Kintsch, 1998), it appears to be feasible to explain L1 and L2 reading and L2 proficiency in a more fine-grained manner that incorporates various cognitive processes involved in them. Understanding at this fine-grained level would enable educators and researchers to diagnose reading problems that English language learners (ELLs) might face with more systematically, in turn resulting in a better design of curriculum, materials, instructional interventions, and assessments.

1.2 The Purpose of the Study

As described in the previous section, the existing theories such as the Linguistic Threshold Hypothesis (Cummins, 1979) and the Linguistic Interdependence Hypothesis (Cummins, 1981) do not provide what kinds of cognitive processes are involved in L1 reading competence, L2 proficiency, and L2 reading comprehension and how they interact because the definitions of such important constructs were not made clear. Thus, the first purpose of the present study is to propose a comprehensive theory that can identify specific cognitive processes involved in each construct (L1 reading competence, L2 proficiency, and L2 reading comprehension), delineate the roles of L2 reading competence and L2 proficiency in the process of L2 reading comprehension, and figure out paths of interaction among specific cognitive processes.

In terms of reading and language learning, Koda (2007) gave a thorough review on crosslinguistic constraints on second language reading development. Since second language reading has been investigated by numerous researchers in the fields of applied linguistics, psychology, and more recently cognitive sciences, the amount of research conducted as of 2007 on aspects of L2 reading comprehension is considerable, and it is extremely difficult to extract global perspectives on how L1 reading competence and L2 proficiency impact L2 reading comprehension. Koda (2007) still quite efficiently organized the information under various categories such as components in reading, linguistic knowledge in decoding, linguistic knowledge in text-information building, linguistic knowledge in reader-model building, mechanisms of learning, reading universal, metalinguistic awareness in reading

acquisition, crosslinguistic variations in metalinguistic awareness and learning to read, language transfer, mechanisms of transfer, impacts of L1 literacy experience, impacts of L2 literacy experience, and so on. While this comprehensive list of categories is a valuable contribution, the relationships among the categories are not clearly identified. This does not provide good guidelines for figuring out important aspects of L2 reading comprehension. In order to consider dual-language involvement, Koda (2007) argued:

Although there is a solid body of evidence that literacy-related competences transfer across languages, little is known how the transferred competencies, shaped in one language, become functional in another. ... However, obtaining such information is not easy because it requires systematic comparisons of qualitative and quantitative changes in particular reading subskills over time across learners with diverse L1 backgrounds. Moreover, such comparisons are practically impossible without solid frameworks through which critical decisions can be made regarding the specific subskills to be compared and the methods of comparison (p. 30).

I maintain that a framework is needed that can delineate global paths of important aspects of L2 reading comprehension and that defines L1 reading competence and L2 proficiency in relation to L2 reading comprehension. The theory of L1 reading comprehension that meets such need is the Construction Integration (CI) model by Kintsch (1998). It identifies three representation systems (surface structure, textbase, and situation model) that are related to specific global aspects of cognitive processes

involved in L1 reading comprehension. Since this model is one of the most widely adopted and respected theories among L1 reading researchers, it has a solid foundation that can be extended to accommodate aspects of L2 reading comprehension as well. Above all, it is the theory that allows for mapping the functions of L2 proficiency into the L2 reading comprehension in relation to L1 reading competence. The detailed introduction of the theory and its extension for L2 reading comprehension will be given in Chapter Two.

The second purpose of the study concerns the empirical investigation of how identified cognitive components such as vocabulary knowledge and L2 proficiency as a function of textbase and schematic knowledge and L1 reading competence as a function of situation model are at work during L2 reading comprehension. Since schematic knowledge is built in students' L1, it is related to L1 reading competence, whereas vocabulary knowledge is a predictor of students' L2 proficiency. Thus, these two variables that represent the textbase and the situation model respectively are explored under the CI model. There are three specific aspects to be explored: (1) whether or not two intervention variables, vocabulary knowledge and schematic knowledge, support and enhance on-line L2 reading comprehension; (2) how two important predictors for L2 reading comprehension, which are L1 reading competence and L2 proficiency, interact with these two treatment variables; and (3) how different types of comprehension measures explain the cognitive processes involved in (1) and (2) in the CI framework.

What is attempted via the experimental study in the specific context (Korea) with a particular group of ELLs who are 9th graders is to explore whether the CI

model for L2 reading comprehension is a viable model for further research and how the roles of different kinds of cognitive processes posited to be important change from the pretests to the posttests after two types of intervention. The role of L1 reading competence can vary depending on the students' educational background and how English is used in their schooling. If English is used as an instructional language, it is considered a second language, whereas if it is learned as one of the subjects in a school curriculum, it is considered a foreign language. English is learned as one of the school subjects in Korea and thus considered a foreign language. The Korean educational system is firmly established in the Korean language, indicating that students can develop their L1 reading competence to a fairly stable level. With this context in mind, thirty two 9th grade Korean students were recruited for participation in the study and tested on science texts before and after the treatment (vocabulary knowledge acquisition and schematic knowledge acquisition).

Chapter 2: Literature Review

Chapter Two fleshes out theoretical background on the proposed theory of L2 reading comprehension. A brief review of L1 reading comprehension provides perspectives on how theories have guided the research on L1 reading comprehension. A review of L2 reading comprehension foregrounds a need for comprehensive theory for L2 reading comprehension. Of several major theories of L1 reading comprehension, the Construction Integration (CI) Model by Kintsch (1998) is the theory that provides the most succinct structure for complex comprehension processes. The details of the theory for L1 reading comprehension is elaborated and extended to explain L2 reading comprehension within this chapter. Since the role of memory is crucial in the CI model, various kinds of memory such as long-term memory (LTM), long-term working memory (LT-WM), and working memory (WM) are elaborated in relation to L1 and L2 reading comprehension. To explain how the design of the proposed study accommodates linguistically and informationally challenging cognitive load at a level that is manageable for the reader, the Cognitive Load Theory (CLT) is introduced. The effects of reducing cognitive loads by means of acquiring different kinds of knowledge (vocabulary knowledge and schematic knowledge) are investigated in the form of advance organizers. Thus, a brief review on the effect of advance organizer is provided. Five hypotheses that are drawn based on the theoretical consideration are introduced in the last section.

2.1 Review of L1 Reading Comprehension

The understanding of the cognitive processes of L1 reading comprehension had gradually been expanded by the work of many researchers over the last 20th century (Rosenblatt, 1938; Baker & Brown 1984; Anderson & Pearson, 1984; Graesser & Kreuz, 1993; Kintsch, 1993; van den Broek, Fletcher, & Risdén, 1993; Kintsch, 1998). Several theories have contributed to the more comprehensive view on reading with their unique perspectives. Pressley and Afflerbach (1995) gave a succinct summary of these theories as of 1995. Unlike the traditional perspective of text having objective meanings, reader response theory (Rosenblatt, 1938) emphasized reader's interpretive variability of text, whose meaning involves "a transaction between a reader, who has particular perspectives and prior knowledge, and a text, which can affect different readers in different ways" (Pressley & Afflerbach, 1995, p. 84). That is, what is comprehended and represented in readers' minds can vary from a reader to a reader. With recognition of "better interpretations that account for more of the elements in a text" (p. 85), various components such as readers' interest in the topic of the reading, reader personality characteristics and attitudes, cognitive maturity, and background knowledge were identified as variables that drive different interpretations of a text among readers. Two different purposes of reading – efferent reading, referring to reading for learning, and aesthetic reading, referring to appreciation of the literature – were also introduced by Rosenblatt (1978), which would later contribute to interpretive variability of text among readers.

Pressley and Afflerbach (1995) identified what was missing in reader response theory as planfulness. They maintained that readers not only respond to text but also

anticipate meanings in text. In making such predictions rather than a simple reaction to a text, readers become highly planful, which requires readers to use various kinds of strategies and comprehension monitoring. This missing piece was complemented by Baker and Brown's (1984) metacognitive theory. Pressley and Afflerbach (1995) summarized this metacognitive view on reading that "mature reading involves active evaluation of understanding as reading occurs, with corrective actions initiated (e.g., rereading, slower reading) when miscomprehension is sensed" (p. 87). Due to unsuccessful monitoring of one's own comprehension state, less skilled readers become less strategic. The effect of metacognitive processes of comprehension monitoring was clearly shown in the study conducted by Palincsar and Brown (1984). When four reading strategies such as predicting, questioning, clarifying and summarizing were explicitly modeled and guided for practice, weak readers not only improved their comprehension right after the treatment periods but also were able to maintain this progress over a longer period of time.

Anderson and Pearson's (1984) schema theory, reinvented after Sir Frederic Bartlett's (1932) classic, *Remembering* (Anderson, Wang, & Gaffney, 2006), also made a big contribution. Schema, defined as "an active organization of past reactions, or past experience" (Bartlett, 1932, p. 201), is an abstract knowledge structure that "summarizes what is known about a variety of cases that differ in many particulars" (Anderson & Pearson, 1984, p. 259). For example, Anderson and Pearson explained that the typical person's knowledge of ship christening has six routine parts; it involves new ships and is done to bless ship just before launching by celebrity in a dry dock with a bottle broken on bow. According to Anderson and

Pearson (1984), these six “nodes,” “variables,” or “slots” are “instantiated” with particular information when this christening schema is activated and is used to interpret a particular event. They also elaborated that this instantiating process is constrained by categorical equivalence for substitution; “for instance, the <celebrity> slot could be instantiated with a congressman, the husband or wife of a governor, the secretary of defense or the Prince of Wales, but not with a garbage collector or barmaid” (p. 260). Thus, the activation of relevant schematic knowledge on the topic of reading not only permits reasonable inferences to be made about details of the event but also affect the allocation of attention to events associated with the topic (Pressley & Afflerbach, 1995).

Attending to the significance of inference making for meaning construction, Pressley and Afflerbach (1995) also included models of text inferential processes as one of the major reading theories. They explicated that many types of inferences such as causal, thematic, spatial, temporal, logical, lexical, and anaphoric had been investigated among researchers (Graesser & Kreuz, 1993; Kintsch, 1993; van den Broek, Fletcher, & Risdén, 1993). They reported that some types of inferences such as pronoun referents, superordinate goals, and causal antecedents showed more reliable impact during on-line reading (Graesser & Kreuz, 1993) than some others that seem to depend on numerous situation factors that include the type of text, the text processor’s orientation to the text, the criterion task the processor expects, and processor characteristics.

The last theory explicated by Pressley and Afflerbach (1995) in their review on L1 reading theories is van Dijk and Kintsch’s theory of discourse comprehension,

which focuses more on the bottom-up process of reading comprehension, initiated with word-level processing. The theory was later elaborated by Kintsch (1998) in detail comprehensive enough to address all the components identified in the previous theories although there exist differential degrees of emphasis and elaboration in each component. Since the Construction Integration (CI) model by Kintsch (1998) is a comprehensive model, which can identify the function of subcomponents of L2 linguistic knowledge, the rest of the section will be spent to explicate what the CI model posits about the processes of L1 reading comprehension and how it can incorporate L2 linguistic knowledge into its model. Before the introduction of the CI model, how L2 reading comprehension has been researched is briefly reviewed so in the following section.

2.2 Review of L2 Reading Comprehension

L2 reading comprehension has been investigated by L2 researchers with differential degrees of influence from such fields as applied linguistics, cognitive sciences, and educational research. The level of analysis and the foci of the investigation vary depending on the grain size that each field attempts to examine. Those from applied linguistics tend to focus on the micro-levels of L2 reading comprehension such as the effects of priming, decoding, morphological knowledge, or a particular linguistic structure (i.e., relative clauses, article, and pronoun). On the other hand, some L2 researchers whose background is educational research are more into the investigation of the social aspects of L2 reading. Those from cognitive sciences tend to emphasize the role of knowledge or schema at a finer level, thus

more psychological rather than linguistic. The complexity of L2 reading comprehension is well attested by this interdisciplinary nature of research.

The very interdisciplinary nature of L2 reading comprehension makes it difficult to develop a comprehensive theory that organizes a great deal of research findings into a economical conceptual framework. Bernhardt (2005) explicated that the 1970s and 1980s were the times that “second language scholars adopted first language conceptual frameworks for conducting research with second language learners” (p. 134), which merely produced many of the variables associated with the L2 reading process. According to Bernhardt (2005), Cummins’ (1984) view of Cognitive Academic Language Proficiency and Basic Interpersonal and Communicative Skills (CALP/BICS) was an important work that conceptualizes language use in different social settings, but it “does not stand as a model with explanatory or predictive power” (p. 136). The research during the 1990s became more systematic in the sense that overarching terms such as the bottom-up/top-down/interactive models (Carrell, Devine, & Eskey, 1998) were used as guiding tools to explain transfer and interference of one language to another (Block, 1992; Chikamatsu, 1996; Harrington & Sawyer, 1992; Horiba, 1996; Koda, 1996; Royer & Carlo, 1991; Tang, 1997).

The studies reviewed under the Linguistic Threshold Hypothesis (Cummins, 1979) and the Linguistic Interdependence Hypothesis (Cummins, 1981) in the statement of problem are the most recent work that has adopted a conceptual framework in relation to L1 reading competence. According to Bernhardt (2005), any models that do not address the influence of L1 literacy experience are not qualified as

a comprehensive theory for L2 reading comprehension because “the 20 % estimate [of L1 reading contribution] appears to hold over age groups and languages fairly distinct from each other” (p. 138).

The meta-analysis on L2 reading comprehension after Bernhardt’s (2005) work is Koda’s (2007). As discussed in the purpose of the study in Chapter One, the work was comprehensive in the sense that it included the findings from various fields that are reflected in the long list of subheadings in the article. Even though the rich findings from various fields are of great value, I concluded that no comprehensive conceptual framework that can explain the relationships among the categories in the list is available at present.

One effort to synthesize the literature in relation to schema theory was made by Nassaji (2002). He used the Construction Integration Model (Kintsch, 1998) to explain the role of knowledge in L2 reading comprehension in the context of schema theory. Nassaji argued that a considerable body of L2 research showed the importance of text-based and knowledge-based processes in L2 reading comprehension, but it failed to address how these processes operate. Since the Construction Integration models (Kintsch, 1998) are computational and memory-based models that “provide a system of rules and mechanisms for how texts are processed, understood, and recalled” (Nassaji, 2002, p. 468), Nassaji argued that it is possible to understand the nature of L2 reading comprehension processes in a more principled and theory-based manner if we apply the Construction Integration Model to the research on L2 reading comprehension. Critiquing the view of the unilateral and fixed effect of schematic knowledge for L2 reading comprehension, Nassaji

(2002) explained that the Construction Integration Model incorporates an interactive nature of bottom-up processing of textual information and top-down processing of schematic knowledge. Nassaji (2002) did not propose constructing a textbase as a function of L2 proficiency explicitly. However, he explicated that L2 readers should overcome more constraints such as inefficient processing of lexical and syntactic information that negatively affect in creating the appropriate textbase.

What has been reviewed in connection with L2 reading comprehension provides a good rationale for introducing a comprehensive theory for L2 reading comprehension. As Koda (2007), Bernhardt (2005), and Nassaji (2002) argued, there is a great need for a comprehensive theory that delineates distinct roles of linguistic knowledge and L1 reading competence or schematic knowledge for L2 reading comprehension, identifies cognitive processes involved in using these kinds of knowledge while reading L2 reading texts, and figures out how these processes interact. Thus, the following sections give an introduction to the Construction Integration Model (Kintsch, 1998) and how it is extended to incorporate L1 reading competence, L2 proficiency and L2 reading comprehension.

2.3 The Construction Integration Model by Kintsch (1998)

2.3.1 General Construct

In an attempt to explain the cognitive processes involved in L2 reading, the Construction Integration model by Kintsch (1998) is adopted and elaborated in a perspective of L2 reading. Using the same model for the analysis of L1 and L2 reading makes it possible to understand the fundamental nature of reading shared by

L1 and L2 reading processes and to compare the differences in these seemingly similar but quite different processes. Since the model identifies specific cognitive processes relevant to building a coherent mental representation of a text, it also makes it possible to identify various potential sources of failure to successful L2 reading comprehension.

According to Kintsch (1998), the initial mental representations of a given text are constructed largely in an associative, bottom-up manner by weak production rules that result in “disorderly, redundant, and even contradictory output” (p. 94). However, this loosely connected output undergoes a process of integration via a constraint satisfaction process in the form of a spreading activation mechanism, which in the end yields a well-structured mental representation. For example, Kintsch (1988) explained that the word, *bank* can activate the lexical nodes BANK1 (financial institution) as well as BANK2 (riverbank) with some of their associates when presented in a text; BANK1 activating MONEY or FIRST-NATIONAL BANK, and BANK2 activating RIVER or OVERFLOW. This rough representation is polished when a reader builds semantic associations with other words in a text such as DEPOSIT or ACCOUNT; the second lexical node is suppressed while the first is integrated into the coherent representation of the text. Kintsch (1998) explained that since this cyclical process that works in short sentences or phrases proceeds over the comprehension of the whole text, whatever has been constructed should be transferred into LTM (long-term memory), which could be retrievable by cues available in sentences except two or three central propositions that stay in WM (working memory) and anchor information into a coherent representation throughout

the text. At the end of reading, a reader is left with “a network of interrelated propositions of various strengths” (p. 103).

Kintsch (1998) proposed that three representation systems, surface structure, a textbase, and a situation model, are involved in comprehension processes. According to him, the surface structure contains exact wordings and syntax used in the text. That is, it concerns recognizing words exactly as they are written in the text and using them to build a mental model of propositions in a process of integration, which is a prerequisite step for building a textbase. The textbase refers to elements and relations that are directly derived from the text itself yielding a series of propositions. These propositions by themselves carry an impoverished or often even incoherent network, and “the reader must add nodes and establish links between nodes from his or her own knowledge and experience [in order] to make the structure coherent, to complete it, to interpret it in terms of the reader’s prior knowledge, and last not least to integrate it with prior knowledge” (p. 103). Thus, he explained that various sources of knowledge such as knowledge about the language, knowledge about the world in general, and about the specific communicative situation must be incorporated in the construction of situation models. He also pointed out that the mental text representation does not necessarily involve equal portion of the contribution from text-derived and knowledge derived information but a mixture of both; thus, either textbase dominance or situation model dominance is possible.

The visual representation of the CI model developed by Mislevy (2007) illustrates cyclical patterns that occur in readers’ mind. The words enclosed within a rectangle under the text are the surface structure of the text. The squares under the

Figure 1.1 An initial cycle of the comprehension process

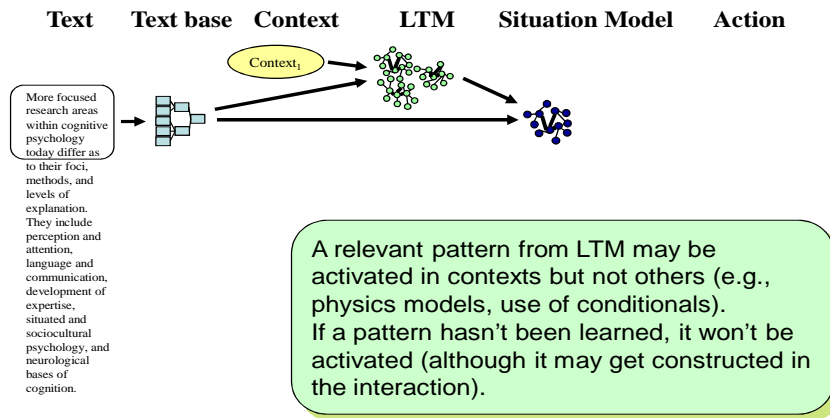

textbase indicate propositions built from the text; the propositions that reflect the same relationships as the surface structure but in different linguistic forms. The circles connected with several lines under the LTM are propositions that are available in readers' background knowledge. These propositions are connected with semantic associations represented by lines. The darkened circles under the situation model are the reader's propositional representation of the text, which is a mixture of textbase and retrieved propositions from their LTM, forming situation model. The arrows indicate the direction of progression or the comprehension of a given text.

Figure 1.1 that represents the CI model (Kintsch, 1988) graphically shows how one cycle of the comprehension process takes place in a sequential order. The construction of propositional representation begins with the recognition of words in a given text; that is, recognizing phrases such as "more focused research areas within cognitive psychology." in Figure 1.1. When these words are chunked in a grammatically accepted manner in a given language community, readers can form a textbase; for example, readers are able to chunk words, "more focused research

areas” as one noun phrase and “*within cognitive psychology*” as one prepositional phrase even if they may not be aware of the grammatical terms for each chunk. If these propositions are represented in exactly the same form as the text in readers’ mental space, it belongs to surface structure. However, studies from recall show that readers tend to remember the same information in different linguistic forms. For example, readers may remember these propositions as “*cognitive psychology has more focused areas for research.*” Thus, even though the semantic information is the same, the linguistic forms that carry it differ, which makes a distinction between a surface structure and a textbase.

These propositional representations can be expanded via long-term memory whose capacity is confined to the availability of relevant knowledge and is moderated by the retrievability of such knowledge. That is, the retrievability can be enhanced by active use of contextual information to the extent of available relevant background knowledge. For example, if readers have rich background knowledge in psychology, they may activate related information that will result in a richer situation model when reading the phrases such as “*more focused research areas within cognitive psychology.*” However, related information may include cognitive psychology as opposed to industrial psychology or more focused areas for research as opposed to more focused areas for practice. The situation model of those with more and better related knowledge will be richer than that of those without such knowledge. In addition, the retrieval of relevant knowledge may be moderated by the context. For example, to help readers make use of context, a title of the text can be provided. If the title of “*research in different areas of psychology*” were given, readers would be

oriented to search their knowledge about psychology, resulting in more active retrieval of relevant knowledge and thus a richer situation model. If the title of the text was “*research and its implications for practice,*” readers are more likely to search for the information on how the knowledge of cognitive psychology is utilized in real life situations. If no title were to be given, readers might not activate any of their background knowledge even if such knowledge is available in their long-term memory.

Figure 1.2 shows how another cycle of comprehension follows as a reader proceeds. For example, words such as “*today differ as to their foci, methods, and levels of explanation*” are recognized as two chunks; *differ* as a verb, and *as to their foci, methods, and levels of explanation* as one prepositional phrase with three noun phrases embedded in it. These relationships can be built as textbase such a way that “*today are different in terms of the foci that cognitive psychologists emphasize, methods that they use, and the details of their explanation.*” Even though the same relationships among words are expressed, the linguistic forms differ. The retrieval of resources in long-term memory plays a role in the same way as described in the first cycle. Thus, the final product, situation model is created as a function of the construction of textbase and the integration of resources in LTM, which can be moderated by contextual clues to some degree.

Figure 1.2 A subsequent cycle of the comprehension process

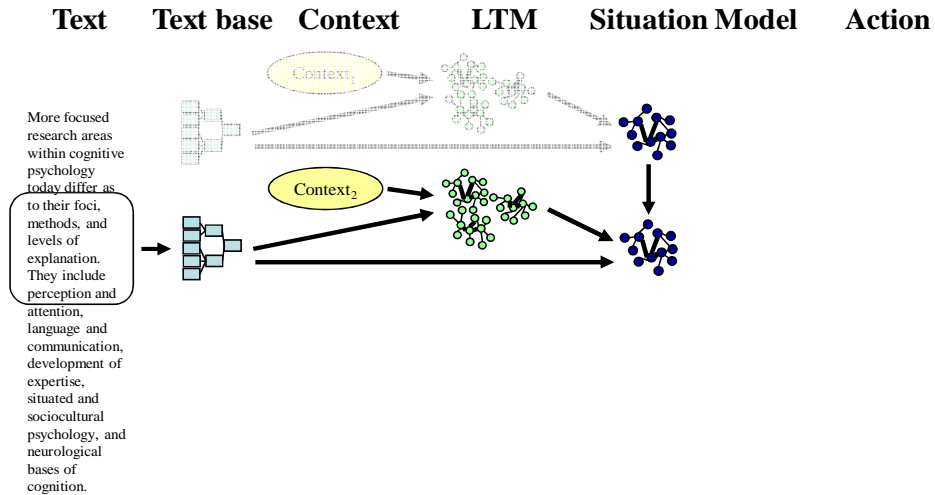

Figures 1.3 and 1.4 explain a scenario that a reader makes some changes in his or her environment by taking some action in order to compensate for the lack of resources in LTM or just to elaborate his/her situation models, such as checking an encyclopedia to clarify his/her understanding on some concepts. The more enriched situation model created by the action taken will bring about some impact on the cyclical task of constructing subsequent situation models.

Figure 1.3 Detecting a comprehension problem and acting on it

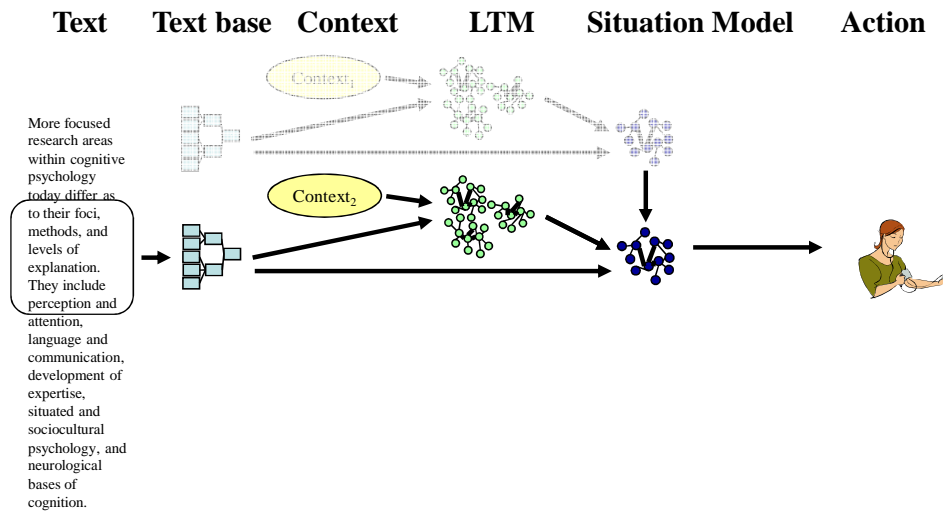
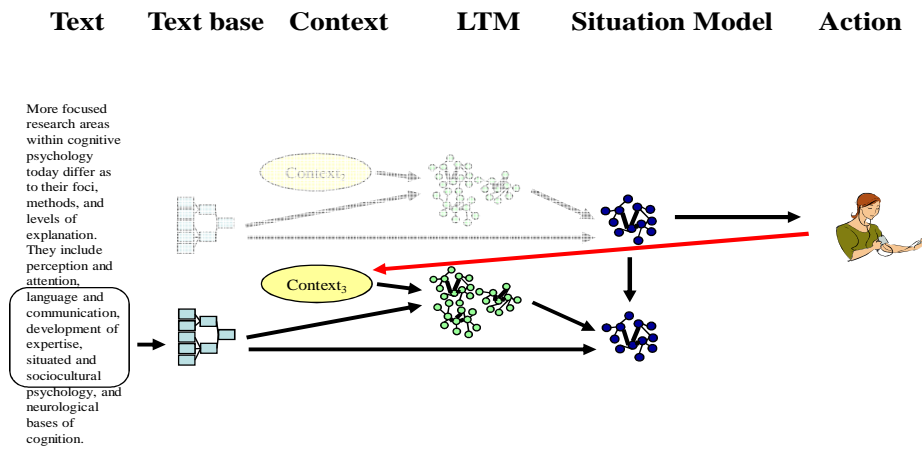

Figure 1.4 Consequences of the reading problem-fixing action



Figures 1.1 - 1.4 enable us to see major sources of information in comprehension and several cognitive processes involved in the comprehension

process and how they interact with each other to reach a final product, a coherent mental representation of a text. There are three external and one internal source of information that contribute to comprehension; text, context and action as external sources and LTM as internal sources. Text, context and action are external sources in that the sources of information in these components come from the outside of a reader's cognition or in that they serve as sources of input rather than the activation of existing knowledge.

As far as a textbase is concerned, the textbase alone does not provide all the necessary information to build a coherent mental representation of the text as Kintsch explained, and a reader should instead activate all the information relevant to the textbase in his or her LTM, in order to fill the semantic gaps in his or her textbase. Therefore, there is one internal source of information that contributes to comprehension, a reader's background knowledge in his or her LTM. The more relevant knowledge to the textbase a reader possesses, the easier the comprehension becomes. The role of resources in LTM has been confirmed by numerous studies that explored the impact of background knowledge or schemata upon reading comprehension; previous studies based on the schema theory have identified the role of schema as an abstract knowledge structure whose nodes or slots can be instantiated with specifics. Since the contextual clues can boost activating relevant background knowledge, the effects of context within a given text can moderate the use of resources in LTM.

In terms of cognitive processes, each source of information has its own characteristic process involved. The first source of information, text requires a reader

to recognize or decode a word and integrate it with other words surrounding it. Perfetti's (1985) verbal efficiency hypothesis addresses the impact of word recognition efficiency; rapid decoding or better word recognition frees up resources for higher-level processing, enabling readers to build more accurate and complete representations of text content. The integration process necessarily entails utilizing syntactic knowledge about a given language or 'parsing' – for example, figuring out what an agent and a patient are or what modifies what. When the language in a text is a reader's native language and readers have developed stable literacy skills, this process takes place more or less automatically. Readers at the beginning stage of literacy have shown that individual differences in phonological and decoding abilities serve as a strong predictor for better reading performances during the developmental stage of literacy (Stanovich, 1986; Siegel & Ryan, 1988, 1988, 1992; Gough, Juel, & Griffith, 1992; Rack, Hulme, Snowling, & Wightman, 1994; Share & Stanovich, 1995).

A reader's LTM, the second major source of information that contributes to building a coherent mental representation of a text, is involved in complex cognitive processes. A reader should first search whether he or she has any information available in his or her LTM that could be of any use to the textbase. At the same time, the information that is retrieved needs to be evaluated based on whether or not it needs to be integrated based on a degree of its semantic association with or relevance to the information in the textbase. It is also likely that a reader may activate information that is not relevant to the textbase and may be misled to reach a representation that is not consistent with textbase. Therefore, it seems critical to be

able to draw information available in one's LTM, evaluate its relevance to the textbase, and integrate it only when it is relevant. It appears that these processes take place unconsciously unless a reader attempts to use their metacognitive strategies. There could be also times that a reader finds that he or she does not have much relevant information to utilize and has to rely on inferencing to connect propositions in the textbase. In such a case, a reader's ability to make logical inferences maximally utilizing relevant information available can be crucial in consequent reading performances.

Even though the CI model did not include metacognitive aspects – the use of various strategies – as a separate entity for a parsimonious explanation of extremely complex processes, the issues addressed by Baker and Brown's (1984) metacognitive theory can be elaborated at this level. The use of pre-existing information, which is a simple retrieval of informational resources in LTM, and general reasoning and strategic problem solving abilities appear to function as independent contributors to reading comprehension as shown by Palincsar and Brown's (1984) study. Kintsch (1988) acknowledged these components; for instance, he described a basic and automatic construction integration process, as “more like perception [rather] than problem solving activity, but when it fails, rather extensive problem-solving activity might be required to bring it back on track” (p. 168). The action, which is the fourth source of information, can play a critical role at this stage, even though many of them can take place unconsciously. A reader may attempt to solve comprehension failure by searching related information on the web, by asking some experts available around them, or by simply summarizing what they have read and try to make active inference

on the problematic portion of comprehension. Unlike the cognitive processes aforementioned, which lie more within a perception realm, taking an action can take place more as a conscious and intentional activity.

2.3.2 The Construction Integration Model for L2 Reading Comprehension

It is supposed that largely the same cognitive processes take place when L2 readers read texts in their own native languages. However, when it comes to an L2, there are some changes to be made to the model. All the cognitive processes that are considered automatic and effortless at a perception level turn into highly conscious, effortful, and intentional activities even though the same variables such as text, textbase, LTM, context, action, and situation model are involved. Of all the components, the biggest difference comes from the textbase. Unlike native speakers of English who construct textbase largely automatically, L2 readers should invest a huge amount of effort in building textbase, including recognizing words and linking them based on the target language rules. Obvious sources of problems are lack of vocabulary knowledge and syntactic knowledge and less automatized retrieval of vocabulary and syntactic rules. In order to build a mental representation of interrelated propositions at a textbase level, this linguistic knowledge – vocabulary knowledge for word recognition and parsing knowledge for connecting words in the way that authors would like them to be understood – is essential, and that the degree of automatization in an access to vocabulary knowledge and syntactic knowledge makes significant impact on the efficiency and the speed of reading.

What is worth noting as to grammatical knowledge is that there are different kinds of grammatical knowledge involved. Skill acquisition theory (Anderson, 1982;

1983), applied to the field of second language acquisition (SLA) (DeKeyser, 2007), posits that the presence of declarative knowledge of grammatical rules is a prerequisite for the automatization of this knowledge for use but not a sufficient condition. . Declarative knowledge that stays in the readers' conscious realm has to be made "available as a ready-made chunk to be called up in its entirety" (DeKeyser, 2007, p. 98) in order for them to get efficiently useful for comprehension or production. The knowledge involved in this intermediate step is procedural knowledge. Unlike vocabulary knowledge, which does not implicate proceduralizing declarative knowledge, grammatical knowledge could be processed at any of the three levels of knowledge, which results in differential implications on comprehension.

The model for L1 readers depicted in Figures 1.1 – 1.4 (Mislevy, 2007) do not include a LTM component at a textbase level because native speakers of English who are said to be literate and educated are assumed to have a stable amount of vocabulary and syntactic knowledge about their native language and a subconscious, automatic access to them in their LTM. Few observations of individual differences are expected in this area due to ceiling effect. If texts are from some specialized fields, it is obvious that native speakers need to learn a considerable amount of vocabulary or concepts to comprehend given texts, which then becomes more like background knowledge rather than linguistic knowledge. Note that the resources in LTM for L1 readers concern more about world knowledge, subject domain knowledge, or word knowledge that has specialized meanings.

However, in the case of L2 readers, both types of LTM resources should be clearly addressed. The LTM resources for linguistic knowledge that accounts for

word knowledge, syntactic knowledge, and a degree of automatized access to them, determine L2 proficiencies. On the other hand, the LTM resources for world knowledge, subject domain knowledge and knowledge about specialized word meanings determine L1 reading competence. Even though these two resources are closely intertwined, which raised a question, whether L2 reading is a language problem or L1 reading problem (Alderson, 1984), the CI model identifies somewhat distinct paths of how each type of resources contributes to L2 reading performance; textbase is a function of L2 proficiency, and a situation model is a function of L1 reading competence.

As to the second type of LTM resources that play a role in building a situation model, it can be said that L2 readers go through mostly the same cognitive processes as L1 readers do – searching, evaluating, integrating, and inferencing. However, there are two potentially influential issues to be considered here. The first is that L2 readers tend to translate a given text into their native language and build a mental representation of the text in their native language, which is likely to consume more processing time and cognitive resources. Even though it is not clear at what levels of proficiency L2 readers start to process L2 textual information in L2, it has been shown that the better the L2 proficiency, the more thinking in L2 is observed (Leontiev, 1981; Cohen, 1998; Guerrero, 2005).

The second issue is that the kinds of information that L2 readers utilize from their LTM are more likely to be different from those that L1 readers bring to the task. There will be quite a big variation in this depending on topics and genres due to her or her knowledge about the world – how people should interact with each other and

how things are related to each other. This kind of knowledge can also vary from culture to culture and even from individual to individual as long as it is not about scientifically shared knowledge. Sets of schemata that work in one culture may have similar structure with similar nodes or slots in another culture, but it is highly possible that these schemata may differ drastically. The more cultural experiences L2 readers have about the target language, the more likely they are able to draw a similar mental representation that good L1 readers come up with.

Therefore, it is worth noting that L2 readers should build a coherent mental representation of a given text with quantitatively and qualitatively less complete information about the text in terms of linguistic knowledge and its automatization for the textbase and qualitatively dissimilar background knowledge for a situation model both at a conscious or intentional and unconscious level than L1 readers. This challenging condition leaves more room for strategic problem solving to play a role. It is commonly assumed that strategy use makes differences in performance when the task is something that is challenging rather than something that can be solved easily – easy tasks can be completed successfully without using any strategies.

Thus, the effect of reading strategies, problem solving strategies, and metacognitive approaches are likely to be more influential in L2 reading than L1 reading. Comprehension breakdown occurs more often in L2 reading and needs intentional, conscious efforts to fix this breakdown. Simple examples of problem solving strategies that utilize an external context component could be the use of dictionary, analyzing syntactic structures and marking them in the text while readers are engaged in L2 reading, or simply asking questions to more advanced readers.

Considering the potential impact of strategy use upon L2 reading, the CI model for L2 reading needs to elaborate the effect of various metacognitive strategies to greater details.

2.3.3 Role of Memory in the CI Model: Long-term Memory (LTM), Long-Term Working Memory (LT-WM), and Working Memory (WM)

Noting a stark contrast of memory between two subjects in a different context, Kintsch (1998) explained the importance of retrieval structures; a little girl who attended an enjoyable party a few days ago remembered a great deal about who said, did, and wore what in the party, whereas a subject who participated in paired-associate experiments with nonsense syllables as stimuli struggled to reproduce a list twice in a row. Noting subjects' dramatic increase of memory (the digit span recalled went up to 30 or more items) after being taught to develop and automate efficient encoding strategies to store digits in Long-Term Memory (LTM) (Chase & Ericsson, 1982), Kintsch explained that the encoders were able to "perceive familiar patterns in the digit sequences that are to be memorized and to associate these patterns with retrieval cues" (p. 219). He explained that schemata retrieved from LTM were activated to organize retrieval cues and turned into stable retrieval structures that supported the quick and reliable recall of the digit sequence to be learned.

In order for the LTM resources to work as an important variable, readers must first have a very rich knowledge base in their LTM that should provide systematic schematic retrieval structures. Readers also should be able to activate these structures and associate them with incoming textual information, which is a process of encoding. Since it is an on-line task under real-time constraint, the

activated structures under Long-Term Working Memory (LT-WM) can be useful only when the operations are rapid and automatic. Therefore, Kintsch (1998) maintained that LT-WM can be used in domains, in which a reader has good knowledge background in LTM, and that LT-WM is unavailable to the extent that such knowledge is lacking, which impacts both on comprehension and memory. This explains how a situation model, which is a function of LT-WM, can boost comprehension and memory of a given text.

Another critically important construct is Working Memory (WM), defined as the capacity to store and manipulate information over short periods of time (Baddeley and Hitch, 1974). WM is differentiated from LT-WM in that it addresses an ability to hold and process novel information without resorting to resources in LTM – this will be discussed in a following section in more details, whereas LT-WM concerns information or retrieval structures activated from LTM (LTM related to a situation model).

One important difference between LT-WM and WM is that LT-WM prerequisites readers to have rich background knowledge, without which there is no room for LT-WM to play a role, whereas WM addresses an ability to deal with novel information without much involvement of background knowledge, where individual differences as a trait can be discussed. As far as L1 reading is concerned, it is not too much of a stretch to say that reading competence is a function of an amount and a quality of background knowledge, which places LT-WM in a prime focal attention. However, when it comes to L2 reading, in addition to the effect of background knowledge, linguistic knowledge is critical, but unlike background knowledge, this

linguistic knowledge has few semantic associations or schematic retrieval structures. Thus, individual differences in WM are likely to be a stronger predictor for L2 reading performance than they are for L1 reading performance. The following table outlines what is addressed in different kinds of memory in relation to L1 reading and L2 reading.

To sum up, one problem identified in the previous section, the absence of theory that provides a comprehensive exposition on complex cognitive processes of reading comprehension was addressed in this section by introducing the CI model by Kintsch (1998). The two representation systems of the CI model have been explicated via graphic representations by Mislevy (2007) in terms of what they are and how they interact, illustrated by the cyclical nature of CI processes. These two components, the textbase and the situation model were expanded to incorporate cognitive processes of L2 reading comprehension in such a way that a textbase is a function of L2 proficiency and a situation model, a function of L1 reading competence; a surface structure was not elaborated in this paper because it involves very local processing levels of word recognition in relation to different L1 orthographic systems, which is not a major part of this study (refer to Koda, 2007 and Hamada and Koda, 2008 for more information on cross-linguistic differences on L2 reading comprehension). In other words, the biggest difference between the cognitive processes of L1 reading comprehension and L2 reading comprehension can be clearly illustrated in the graphic representations of the CI for L1 readers by Mislevy (2007) by inserting a component of L2 linguistic knowledge resources in LTM.

Table 2.1 Memory in relation to L1 and L2 reading

	Relevance in L1 Reading		Relevance in L2 Reading
LTM (long-term memory)	<ul style="list-style-type: none"> . Availability of background knowledge (topic-specific) . should be analyzed in terms of quantity and quality (organization of knowledge) 	+	<ul style="list-style-type: none"> . Availability of linguistic knowledge (vocabulary knowledge and grammatical knowledge) . should be analyzed in terms of quantity and quality (different degrees of automaticity)
LT-WM(long-term working memory)	<ul style="list-style-type: none"> . Activated knowledge from LTM serves as retrieval structures for processing current textual information. . The quality and quantity of activated knowledge critically moderate the amount of information to be understood and remembered. 	+	<ul style="list-style-type: none"> . Activated linguistic knowledge from LTM facilitates bottom-up processing but does not provide systematic retrieval cues for overall comprehension. . Different degrees of automaticity in linguistic knowledge play a critical role in the activation of linguistic knowledge. . LT-WM of background knowledge and LT-WM of linguistic knowledge have recursive relations (mutually facilitating effect).
WM (working memory)	<ul style="list-style-type: none"> . An ability to deal with novel information . The kind of new information is likely to be topic-specific. 	+	<ul style="list-style-type: none"> . Novel information is processed via LT-WM of linguistic knowledge, which is moderated by its different degrees of automaticity. . Less automatized linguistic knowledge poses greater burden on the processing of new information. . The shortage of linguistic knowledge creates many holes and gaps that need to be filled by inferencing, which taxes WM to a greater degree.

+ indicates that everything described about L1 is relevant to L2 reading.

Due to the cognitive complexity of and cognitive demands on L2 reading processes, the role of memory becomes an even more relevant issue to L2 reading comprehension than L1 reading comprehension. It was explained that LT-WM is a function of the availability of stable and systematic retrieval structures in readers' LTM (Kintsch, 1998) and moderates or even mediates what is remembered and comprehended during reading. Unlike informational resources in LTM, which are organized based on semantic associations among themselves, linguistic resources in L2 readers' LTM do not take on these systematic features. Thus, the role of WM that handles novel information becomes more prominent in L2 reading comprehension; retrieval of less automatized L2 linguistic knowledge and holding it

under the space of WM for on-line integration processes poses extremely demanding conditions on the function of WM. Considering these critical roles of WM and LT-WM in L2 reading comprehension, more thorough review is needed and provided in the following section.

2.4 Role of Memory in Reading Comprehension

2.4.1 General Construct of Working Memory (WM)

It appears that there is some debate over what Working Memory (WM) is composed of and how each component identified by a particular model functions despite a widely perceived consensus on its significance upon various cognitive processes relevant to reading. This is attested via a huge number of studies that have investigated WM over several decades. By cross-searching in PsycINFO database with the term, 'WM' and 'reading' together gives results of 964 studies in all fields and 133 studies in title words as of 2007. However, it could be misleading to use the term, 'WM' as one unitary entity when it is in fact a composite of several independent variables with some shared variances among them. This could be even more problematic when interpreting and synthesizing the results of various studies that have claimed that they have tested the function of WM unless the components that have been tested and the measures that have operationalized the components of WM are clearly defined. For this reason, it is necessary to begin with an overview of a model of WM that has identified its multi-components together with the measures that have been widely used to operationalize each component of the model and with

studies that have reported evidence for the multi-component feature of WM and its significance in reading.

The model of WM was introduced by Baddeley and Hitch in 1974. Even though the term 'WM' appears to have been invented by Miller, Galanter and Pribram (1960) and was used by Atkinson and Shiffrin (1968) according to Baddeley (2007), it appears that the three-system model that Baddeley and Hitch (1974) presented has been widely used and remained influential in neuroscience and developmental psychology as well as cognitive psychology due to its interpretive power with empirical data (Andrade, 2001). Unlike the unitary short-term store proposed by Atkinson and Shiffrin (1968), Baddeley and Hitch (1974) characterized the model with a multi-component nature of memory in the short-term store, which is composed of an attentional control system, the *central executive* along with two slave storage systems, the *phonological loop* and the *visuospatial sketchpad*. The latter two components are called slave systems in that they are always subject to the central executive component due to its controlling feature to execute each component. They argued that all three systems were limited in capacity with their own kinds of limitations.

According to them, the phonological loop is a system that holds speech-based and possibly purely acoustic information in a temporary store, whose storage is assumed to be dependent on a memory trace that would fade within seconds if not rehearsed in a form of either overt or covert vocalization. The second slave system, the visuospatial sketchpad concerns visual and spatial information. Baddeley (2007) explained that the visual aspects of the system are concerned with patterns or objects

while a spatial component is concerned with location, which makes it possible to make a distinction between them. He argued that studies on brain-damaged patients and studies of normal brain function using neuroimaging techniques (Jonides, Smith, Koeppel, Awh, Minoshima, & Mintun, 1993; Smith and Jonides 1997; Della Sala and Logie 2002) provided some evidence for multi-component of WM rather than unitary. Conway, Kane, and Engle (2003) also reported:

Storage-only tasks reveal activation primarily in areas related to the content of the to-be-remembered material (e.g., Broca's area for verbal material, right-hemisphere pre-motor cortex for spatial materials; Smith and Jonides, 1999), whereas storage-plus-processing tasks reveal content-specific activation but also domain-free activation in areas such as dorsolateral prefrontal cortex (DLPFC) and anterior cingulate (ACC) (Fiez et al, 1996; Jonides et al., 1998; Smith and Jonides, 1999) (p. 550).

The measure that has been most commonly used for phonological loop is a non-word repetition task or a serial recall task, where participants are given a digit/letter string or semantically unrelated word sequence and asked to recall the order. In order to recall the correct order of the serial or sequence, one is expected to have a better storage capacity for phonological information on hold before recall. The reading span task (RST), which was introduced by Daneman and Carpenter (1980) and have been widely used to investigate relations between WM and reading, is assumed to tap the central executive because it involves not only a storage component but also a processing component and an attentional control to inhibit or suppress irrelevant

information to recall the target word (Osaka et al. 2002). In the original RST task, subjects were given a series of sentences to read aloud and then asked to recall the final word of each sentence. The reading span was the number of final words recalled correctly. In a modified version, a simple comprehension question on the sentence was inserted to secure the component of processing in the task – for example, in the sentence span task by Swanson (1992). The visuospatial sketchpad, which has been relatively less frequently tested in relation to reading, was measured using a visual matrix (Swanson, 1995), where participants were asked to remember visual sequences of dots within a matrix, and mapping and directions (Swanson, 1992), where participants were to remember sequences of directions on an unlabeled map.

One study by Swanson and Howell (2001) showed evidence for the multi-component model of WM in reading; two slave systems (the phonological loop and the visuospatial sketchpad) are independent from each other but share some variances in common for a domain general system, the central executive. They compared two components of WM; 1) verbal WM operationalized in a reading span task, which is assumed to test the phonological loop and the central executive together, and auditory digit sequencing (numerical recall task), which is assumed to test the phonological loop; and 2) visual-spatial WM operationalized in visual matrix and mapping directions. The reading comprehension (the Woodcock Johnson Reading Mastery Test and Revised-Reading Comprehension subtests) and word recognition task (the Wide Range Achievement Test and Reading subject score) were used as dependent variables for hierarchical regression analyses. In the hierarchical regression analysis of data from the 100 fourth and ninth grade children, the verbal WM showed a

significant contribution to reading comprehension and word recognition after partialling out the effects of articulation speed and short-term memory (STM). When the visual-spatial WM was entered after the verbal WM, no significant contribution of the visual-spatial WM was found. However, when the order of entry was reversed, a significant contribution of the visual-spatial WM was found, with still a significant contribution of verbal WM.

Based on the results, Swanson and Howell (2001) argued that it was the verbal tasks that isolated the significant contribution of WM to word recognition and reading comprehension. The result of the second-order factor (variance from both the verbal and visual-spatial WM tasks significantly predicted both reading comprehension and word recognition) served as evidence that a domain-general WM system, the central executive, does contribute important variance to reading comprehension and word recognition beyond what is contributed by processes related to STM and articulatory speed. The significant variance by visual-spatial WM in the reversed order model (visual-spatial WM first entered) includes the portion that the verbal and visual-spatial WM share together, which is assumed to be central executive and the pure portion that the visual-spatial WM, which was not significant on its own. Then, the significant contribution that verbal WM made to reading comprehension and word recognition after partialling out other variables including the visual-spatial WM (verbal WM in the reversed order) is assumed to be the pure portion that verbal WM explains, the portion with the removal of the central executive. Therefore, the multi-component model of WM is supported by this study;

- 1) verbal WM, which is composed of pure verbal WM and domain-general central

executive, is significantly correlated to reading comprehension and word recognition respectively; 2) visual-spatial WM, which is the portion without domain-general central executive, is not significantly correlated to the dependent measures on its own; and 3) the domain-general central executive, which was included in the visual-spatial WM in the reversed order, had a significant contribution to the outcome measures.

2.4.2 Working Memory (WM) and L1 and L2 Reading

Cain, Oakhill and Bryant (2004) studied the relations between L1 reading and WM. They assessed the progress of one hundred and two 7-8-year olds in such areas as Neale word reading accuracy, Neale reading comprehension, verbal IQ, and British picture vocabulary scale to name a few, in which individual differences have been identified for reading. Two WM measures, sentence span task and digit span task, were used to assess the children's WM. In order to determine whether WM explained additional variance in comprehension, they conducted fixed-order hierarchical multiple regression analysis with reading comprehension as the dependent variable and WM (composite scores of sentence and digit span tasks) and component comprehension skills as independent variables after controlling for word reading, vocabulary, and verbal IQ. The results showed that the combined WM explained significant variance in reading comprehension above and beyond the contribution made by the other variables at each time point of the 8th, 9th, and 11th years. This led them to conclude that WM should be considered one of several factors that can influence comprehension ability and comprehension development.

Concerning the interplay of two WM span tasks, the sentence span task was more highly correlated with reading comprehension and the component skills than was the digit task. However, significant correlations between the two WM assessments found that at each time point it showed that both of the tasks tap a common construct. This is not surprising because a sentence span task is assumed to tap a composite of the storage and processing, while a digit span task is expected to address only storage aspect of phonological loop. This is consistent with the assumption of the multi-component model of WM that phonological loop is independent but subject to the central executive processing system. It seems that the phonological loop alone (digit span task or non-word repetition) does not have much power to explain the individual differences in reading comprehension because the digit task showed significant correlations only with reading comprehension and inferencing making at Time 2, and Vocabulary subset at Time 3 in addition to significant correlations with the sentence span task across all time points in this study.

This result of the digit task is consistent with what Daneman and Carpenter (1980) reported. They reported that when the standard digit span test or a probe digit span test was used, no systematic differences were found between good and poor readers who were classified on the basis of a general reading comprehension test. They also reported that letter strings or similar sounding words had been only slightly more successful as predictors of reading comprehension. However, Thorn and Gathercole (1999) also argued that “adequate short-term representations of the phonological forms of new words represent a critical stage in their becoming part of the permanent lexicon, and therefore that individuals with relatively poor

phonological loop function are less successful in learning in the sound structure of new words” (p. 303). This implies that phonological loop can be a good predictor for reading comprehension, given that vocabulary knowledge is significantly correlated to reading comprehension.

This seemingly conflicting evidence regarding the role of the phonological loop for reading comprehension had been addressed by the earlier study (Gathercole, Willis, Emslie, & Baddeley, 1992). They explored the developmental association between phonological memory and vocabulary knowledge at children’s ages of 4, 5, 6, and 8 years. They found a significant shift in the causal underpinnings of the relationship between phonological memory and vocabulary development before and after 5 years of age. Based on the data they collected, they argued that phonological memory skills appeared to exert a direct causal influence on vocabulary acquisition between 4 and 5 years but this pattern weakened because vocabulary knowledge itself took the role of the phonological memory afterwards. Although not fully disclosed, the role of phonological loop appears to play a critical role in the beginning stage of language learning. This influence in the earlier stage of language acquisition explains little significant contribution of digit span tasks to reading comprehension for adults or older children. This issue could be critical for second language acquisition(SLA) because most of the second language learners stay at the beginning stage of second language development over a considerably longer period of time than do those of native speakers, and it is highly likely that word knowledge would play a critical role in L2 reading as well.

The relation between L2 reading and WM was explored by Harrington and Sawyer (1992). In order to test the extent to which differences in L2 reading skill can be reliably related to differences in L2 WM capacity, three types of WM measures – digit span, word span, and reading span – were given to 35 Japanese advanced English language learners in both Japanese and English. TOEFL grammar, TOEFL reading, and 350-word cloze tests were used for L2 comprehension measures. The result of the study was that only the correlation between English reading span task and TOEFL reading was found to be significant. Both English digit span and English word span failed to show any significant effect on L2 reading, which is consistent with the findings of L1 reading. The correlation between L1 and L2 reading spans was significant but only at the $p < .05$ level, whereas the correlations between L1 and L2 digit and word spans were significant at the $p < .01$ level. Another study that investigated this issue was the study by Osaka and Osaka (1992). They compared L1 Japanese/L2 English participants for the relation between WM and L2 reading, using three kinds of WM measure; Daneman and Carpenter's (1980) RST, Japanese version of RST and an English-as-a-second-language (ESL) version. They found significant correlations between the Japanese and ESL versions of RST as well as between the Japanese version and Daneman and Carpenter's RST. In a follow-up study, Osaka and Osaka (1994) found the same result when they compared L1 German/L2 French participants.

As Harrington and Sawyer (1992) argued, an issue of whether L1 and L2 WM shows consistently significant correlations, independent of relative proficiency in the L2 is worth further exploring because it can provide insight into models of L2

aptitude. L1 WM is stable and is highly correlated with reasoning ability ($r = .80-.90$) (Kyllonen and Christal, 1990); Conway et al. (2003) reported that the review of recent studies have shown that WM and g are highly correlated but not identical. However, L2 WM is severely confined to L2 proficiency; unlike L1 WM, L2 WM capacity develops as L2 proficiency improves over a longer period of time. In this sense, L1 WM can be considered a trait but L2 WM may not. However, if L1 WM would be found to be correlated with L2 WM at all proficiency levels, we could infer that L2 WM capacity can be interpreted as a trait component after partialling out L2 proficiency. How the findings to be explored should be interpreted needs more consideration.

The central executive was explored by Osaka Nishizaki, and Komori (2002). Noting the function of inhibiting irrelevant information for better recall in the reading span task (RST) (Daneman & Carpenter, 1980), they investigated a processing aspect of WM, the central executive by creating two conditions (a focused RST and a nonfocused RST). In a focused RST, the word to be recalled is the focus word in meaning (no inhibitory process involved), whereas in a nonfocused RST, the word to be recalled is any word other than the focus word in the sentence, which consequently involves taxing an inhibitory function of the central executive for attentional control. In the first experiment, they tested the effects of focus word for recall. The recall task of 30 Japanese participants under the two types of conditions (focused RST and nonfocused RST) revealed that the mean span score was significantly higher for the focused RST than for the nonfocused RST, confirming the effect of focus word in meaning for better recall. In the further analysis on the intrusion error (the number of

nontarget words belonging to the set of sentences that were incorrectly recalled), they found that in the nonfocused condition, the rate of providing a focus word for recall was significantly higher than that of providing other nontarget words. This attests the stronger power of a focus word in meaning for recall than other nontarget words in the sentence.

In order to test individual differences in an ability to inhibit irrelevant information using focus word as a distractor for recall, they compared 23 high WM subjects with 23 low WM subjects using the same task in the first experiment. ANOVA revealed that there was a significant main effect of focus and WM group along with a significant interaction between them. Further analysis showed that recall was higher for the focused RST than for the nonfocused RST for the low WM group, whereas there was no significant difference in the recall between the focused RST and the nonfocused RST for the high WM group. The significant difference between the focused and nonfocused RST groups for the low WM group indicates that distractors (focus word in nonfocused RST condition) made a significant confusing effect in the recall task and those in the low WM group were not able to inhibit distractors successfully due to their low WM resources. However, this confusing effect of distractors was not found in high WM group because their high WM resource enabled them to successfully inhibit the distractors. These findings lead us to a conclusion that an ability to inhibit irrelevant information, which belongs to processing, does explain individual differences in recall. Even though this central executive component of WM was conducted at a sentence level in this study, we can safely extend its implication to text comprehension because text comprehension

involves building a mental representation of hierarchical information in its generality over an extended period of time across numerous sentences. In order to hold core propositions in memory successfully and efficiently, readers should suppress less important information and integrate incoming information with the core propositions remaining in their memory. Therefore, the central executive can be assumed to play a significant role in reading comprehension, and many of the studies that explored the relationship between reading and central executive, operationalized via reading span task, have indeed shown such a result (Daneman and Carpenter, 1980; Swanson, 1992; Cain, Oakhill, & Bryant, 2004).

2.4.3 Episodic Buffer and Long-Term Working Memory (LT-WM)

The newest component, the *episodic buffer* (Baddeley, 2000) is an addition to its original three component model. Baddeley (2007) explicated that the capacity to remember large chunks of prose that have been observed in many studies needs to be addressed in his model of WM. In fact, the concept of the episodic buffer was addressed by Ericsson and Kintsch (1995), who termed it as ‘LT-WM’ (LT-WM). They argued, “as WM has been considered in a wider range of complex tasks, theorists have found it increasingly difficult, if not impossible, to model the associated cognitive processes with only around four chunks in WM” (pp. 212, 213), the number which traditional short-term memory (STM) had generally found to be possible for memory, and which is mostly consistent with the limited capacity of WM for many unfamiliar tasks used in laboratory studies. According to them, the model Baddeley and Hitch (1974) proposed did not explain WM for skilled activities, in

which a huge amount of information held in the LTM can be activated for immediate use to meet current or on-line task demands as shown in the studies by Chase and Simon (1973). They found that chess experts could utilize a large number of specific patterns of chess pieces in LTM when given representative stimuli from their domain of expertise as retrieval cues while the expert's advantage disappeared with chess boards as stimuli that have randomly arranged chess pieces in the memory tasks.

Kintsch (1998) explained that more direct evidence of LT-WM for text comprehension comes from the study by Glanzer and his colleagues (Glanzer, Dorfman, & Kaplan, 1981; Glanzer, Fischer, & Dorfman, 1984; Fischer & Glanzer, 1986). The task they used was a text with an unrelated sentence inserted after each sentence of the text for various lengths of time. Surprisingly, they found no effect of the interruptions whatever on comprehension; furthermore, there was no difference in accuracy of comprehension questions between the interrupted text and the text without any interruptions. Kintsch (1998) argued that the classical theory of WM can not explain these results because reading an unrelated sentence was supposed to wipe out any traces of the prior text from the reader's STM in the classical model. He instead claimed that the theory of LT-WM readily accounts for the observed results by arguing, "The next sentence of a text following an interruption provides the cues in STM that can retrieve the LTM trace of the previous text from LT-WM. The mental structure that the reader has created in the process of comprehending the text itself functions as a retrieval structure" (p. 223). Thus, associative semantic strength among sentences in the text allowed subjects to suppress the effect of interruptions and enabled them to hold the coherent mental representation of the text. Baddeley

acknowledged that “performance on such complex tasks as reading comprehension could not be explained within the existing framework [the model of three-component WM], where memory storage was limited to the loop and the sketchpad, each of which could hold information only briefly, and which had no specified means of interaction” (Baddeley, 2007, p. 12). Then, he suggested that the episodic buffer, which is assumed to form an interface between the three WM subsystems and LTM, serves as a binding mechanism.

Even though no study has directly explored the role of episodic buffer as a separate independent variable in reading comprehension, there have been some studies that explored WM in relation to background knowledge or topic familiarity in reading. Since background knowledge comes from readers’ LTM and an episodic buffer is defined as an interface between the three WM subsystems and LTM, the studies on the impact of background knowledge on reading can address this construct of WM. However, it should be noted that the use of background knowledge reviewed here does not address the quality of retrieval structures but rather a presence of background knowledge, which can be activated promiscuously at all comprehension levels, rather than in a systematic expectation-driven manner in the way schematic knowledge works.

Miller, Cohen, and Wingfield (2006) hypothesized that contextual knowledge would increase reading efficiency by reducing demands on WM capacity, which would be supported by 1) increased reading efficiency among readers given prior contextual knowledge relative to those not given this knowledge and 2) larger differences in reading efficiency between high and low WM span groups among

readers without prior knowledge than among readers with prior knowledge. The 200 young and older adults in Miller et al.'s (2006) study were divided into either a title or a no-title group, which operationalized contextual knowledge within each age group (young vs. older). The measure for WM was a loaded sentence span task, in which the participants were asked to respond "true" or "false" to an increasingly larger set of sentence statements and were asked to repeat the list of sentence-final words from that set in a correct order. The reading efficiency was computed by dividing the median clause reading time for each passage by the number of propositions recalled for it, that is, time in milliseconds per proposition recalled. The findings supported their hypotheses; ANOVA (between subjects comparison) revealed a significant main effect of WM span, which indicates that the reading efficiency varied as a function of WM capacity (confirmation of the hypothesis #1), and significant interaction with contextual knowledge (title), which suggests that WM span was more important among participants who did not receive passage titles than among those who did (confirmation of the hypothesis #2). The findings indicate that the no title text created a condition where readers should tax more cognitive load for comprehension and this cognitively more demanding condition favored those with high WM who could spare additional cognitive resources to compensate for the lacking information. These findings confirmed the assumption about the compensatory function of WM and background knowledge for reading comprehension.

Topic familiarity in L2 Reading and WM was investigated by Lesser (2007). He reported that topic familiarity has been found to have a significant positive effect

(either main effect or part of complex interaction) in various L2 reading studies (for example, Johnson, 1982; Lee, 1986; Barry & Lazarte, 1995; Bugel & Buunk, 1996; Carrell & Wise, 1998; Chen & Donin, 1997; Pulido, 2004), although a few studies have not (Carrell, 1983; Peretz & Shoham, 1990; Hammadou, 1991). He analyzed the scores of topic familiarity and WM (the composite z scores of mean reaction times for the correctly judged sentences, the number of correctly judged sentences, and the number of sentence-final words correctly recalled) in relation to comprehension recall as a dependent variable. The 94 participants were beginning English Spanish learners in college. The result of ANOVA showed significant main effects for topic familiarity and for WM, high WM recalled a greater percentage of text propositions than low WM, and the difference between medium and low also approached significance. Pairwise Tukey HSD post hoc comparisons revealed that the higher WM groups (high and medium) that read familiar passages outperformed learners who read unfamiliar topic passages regardless of WM. Within the familiar condition, those with high and medium WM recalled more than those with low WM, whereas there was no significant difference among WM groups in the unfamiliar condition.

The above result is not consistent with what Miller et al. (2006) found in L1 reading; differences between high and low WM groups were greater within the no title condition, which is equivalent to the unfamiliar condition in Lesser's study (2007) than in the title condition, equivalent to familiar condition. This conflicting evidence on the role of background knowledge in relation to WM has been addressed by Hambrick and Engle (2002) in their two hypotheses on possible patterns of interplay between domain knowledge and WM on comprehension; 1) relevant domain

knowledge can compensate for low WM during comprehension, but high levels of domain knowledge might attenuate or even cancel out facilitative effects of WM, which indicates that the difference between high WM and low WM is narrowed in the familiar/title condition or maximized in the unfamiliar/no title condition – what Miller et al. (2006) found; and 2) high levels of WM enhance relevant domain knowledge, representing a “rich-get-richer” hypothesis – greater WM capacity might only facilitate comprehension if participants possess sufficient background knowledge, the result that Hambrick and Engle (2002) and Lesser’s (2007) studies found favorable evidence for.

Although it appears to be valid to interpret the effect of background knowledge as a function of encoding and retrieval structures from LTM, the two hypotheses proposed by Hambrick and Engle (2002) still need to be explained. My interpretation of the findings of two studies (Miller et al., 2006 and Lesser, 2007) is that the different degree of task demands may have played a significant role. The study by Miller et al. (2006) used L1 reading performance, whereas the study by Lesser (2007) used L2 reading performance, a condition in which readers should deal with not only informational but also linguistic input, creating higher cognitive processing demand. When the task demand is too high (e.g., an unfamiliar L2 reading condition in Lesser’s study), there could be floor effect to occur; high WM does not compensate for a task demand, which is unfamiliar L2 reading). On the other hand, ceiling effect could be possible when the task demand is too low (e.g., familiar L1 reading condition in Miller et al. study); good comprehension can occur even without taxing extra cognitive resources. It should be noted, though that the

level of task difficulty is always dependent on learners' resources in LTM; nature of a given task, amount and quality of background knowledge available, and differential WM capacities all contribute to the level of task difficulty.

In addition to this interpretation, there could be several other plausible scenarios at a more general sense that could account for different results on the interplay between background and WM; 1) readers with high WM could decide to further explore the meanings of the text and get involved in various semantic manipulations, which could result in other kinds of cognitive processes such as figuring out text structures, making inferences, and comprehension monitoring, which would lead to deep understanding; 2) they could be satisfied with what they have understood and stop engaging themselves further into deeper levels of semantic exploration, which is likely to result in shallow, surface-level comprehension, which then becomes a more motivational issue; or 3) there could be simply no more information that they could extract from the text due to the lack of linguistic knowledge (language proficiency as a bottleneck or threshold effect), which results in partially constructed mental model of the text. Despite methodological difficulties, all of these scenarios appear to be worth further investigation.

Such qualitative aspects of WM – how differently those with high WM consume their cognitive resources from those with low WM during reading – have been explored via eye fixations. Kaakinen, Hyona, and Keenan (2003) investigated how prior knowledge, WM capacity, and perspective relevance of information affect eye fixations in expository text. Forty-seven college students were given a particular reading perspective and then asked to read the texts (eight lines of text in one screen)

at their own pace from the computer screen while their eye movements were tracked and recorded. The RST by Daneman and Carpenter (1980) was administered after reading the texts. After the recall task, they filled out a questionnaire about background knowledge on the topic of the text (familiar diseases text vs. rare diseases text) that they read. Fixation time measures consisted of three sub-measures; 1) first-pass progressive fixation time - the time of forward-going fixations that land on unread parts of a sentence and are thought to index the most immediate processing; 2) first-pass rereading time - the summed duration of fixations landing on the already read parts of a sentence during the first-pass reading that reflects the reader's immediate need to reread a sentence; and 3) look-back time – fixations returning to a sentence from subsequent sentences, the purpose of which is to reinstate text information to their WM.

The study showed that high WM readers seem to invest extra processing time to relevant information already during first-pass progressive fixations, whereas low WM readers speed up processing of irrelevant information and invest extra effort later. The high WM group showed a general slowdown in the first-pass progressive fixation time, which implies longer time processing both relevant and irrelevant information in their first attempt to comprehend the texts, while the low WM group used less time on first-pass progressive fixations in irrelevant information. The general findings that the authors reported were that high WM readers did not need extra processing time to differentiate relevant/irrelevant information and to encode it based on its weight of importance to memory when reading a text of familiar contents. They interpreted the result that “individual differences in WMC can be

explained as differences in the ability to encode and to retrieve information from LTM by using already existing knowledge structures” (Kaakinen, Hyona, and Keenan, 2003, p. 456), in line with the argument made by Ericsson & Delaney (1999) and Ericsson & Kintsch (1995). However, considering the complexity of the issue, it needs to be corroborated by more empirical studies.

Another line of research that explores the episodic buffer or LT-WM indirectly was conducted by Hannon and Daneman (2001; 2006). They came up with four-component model for measuring and understanding individual differences in reading comprehension (Hannon & Daneman, 2001), whose components are a text memory component, a text inferencing component, a knowledge integration component, and a knowledge access component. Using six sets of three-sentence paragraph, each component was designed to measure its own distinctive characteristics. For example, participants were given one paragraph with three sentences such as “*A NORT resembles a JET but is faster and weighs more.*”; “*A BERL resembles a CAR but is slower and weighs more.*”; and “*A SAMP resembles a BERL but is slower and weighs more.*” After given a self-paced study session, they were asked to mark true or false on several statements: for example, for the text memory component, “*A NORT is faster than a JET*”; for the text inferencing component, “*A SAMP is slower than a car*”; for the knowledge integration component, “*A ROCKET is faster than a SAMP*”; and for the knowledge access component, “*A jet has a pilot, whereas a MOTORCYCLE doesn’t.*” In the knowledge integration component, participants should have knowledge that a rocket is faster than a car and should activate this knowledge to integrate the information inferred from

the text, a SAMP is slower than a car in order to come up with a correct answer, which is true. The knowledge access component does not involve any information stated or inferred in the passage but asks participants to activate their general world knowledge.

To determine the extent to which the component processes task and a working memory span task tapped similar processes, sharing common variances for predicting reading comprehension abilities, they conducted two stepwise regression analyses by entering measures of working memory (reading span task), text inferencing, speed, and high-knowledge integration. The first analysis which entered working memory span as the first predictor showed that 21 % of the variance in reading comprehension performance was explained by working memory span task and the rest of the predictors such as text inferencing, speed, and high-knowledge accounted for 29% of the variance in reading above and beyond working memory span. However, when the working memory span was entered as the last predictor, text inferencing explained 23 % of the variance, speed, 13%, high-knowledge integration, 11%, and working memory only 3%. Hannon and Daneman explained that “the working memory span test shares most variance in common with the text inferencing component of our component processes task” (Hannon and Daneman , 2001, p. 121) because “text inferencing is the component whose predictive power is most reduced by entering working memory span as the first predictor” (Hannon and Daneman , 2001, p. 121). Based on the findings, they argued that “our component processes task accounts for most of the variance in reading comprehension that is accounted for by a typical measure of working memory capacity, and it accounts for

variance not accounted for by working memory, such as variance associated with access to prior knowledge and speed of reading and responding” (p. 121).

Since the four-component model incorporates aspects about accessing prior knowledge and integrating it with the textbase information, it could serve as a good alternative to a measure of LT-WM. However, this finding is limited only to population of college level students of English as their first language. The relevancy of the framework to ELLs and different age groups such as those in the K-12 contexts should be explored. Considering the amount and quality of L2 linguistic knowledge and its unstable nature (less automatized), the role of working memory for L2 reading comprehension needs to be investigated in relation to this four-component model.

To sum up, the multiple-component model by Baddeley and Hitch (1974) (central executive, phonological loop, and visual-sketch pad) was introduced along with the study that experimentally showed independent contributions of each component in relation to reading (Swanson & Howell, 2001). The evidence of RST (reading span task) as a significant predictor for L1 reading comprehension over a three-year period was provided and elaborated in details via Cain, Oakhill and Bryant’s (2004) study. The contradictory evidence on the effect of phonological loop, realized in a simple digit span task or a nonword task, was addressed by several studies; no or little effect for older children and adults from the studies by Cain et al. (2004) and Daneman and Carpenter (1980); significant effect for younger (4-5 years old) children from the study by Gathercole et al. (1992). The significant relationship between L1 RST and L2 RST was also confirmed by several studies (Harrington & Sawyer, 1992; Osaka & Osaka, 1992 for English and Japanese; Osaka et al. 1994 for

L1 German and L2 French). The role of RST was explored and confirmed as a function of central executive by Osaka et al. (2002) by manipulating a word to be recalled, a semantically focal word or a semantically non-focal word, in each of which inhibitory function differs.

A new component, episodic buffer was proposed to be a function of LT-WM (Ericsson & Kintsch, 1995) in that it serves as interface between three WM subsystems and resources in LTM. The studies reviewed concerning LT-WM investigated the role of background knowledge in relation to those with high vs. low WM under the assumption that those with more background knowledge would enjoy better LT-WM while reading. The study by Miller et al. (2006) found those with lower WM to benefit from the title-condition to a greater degree in L1 reading. The study by Lesser (2007) also confirmed this pattern that topic familiarity reduces the processing burden of a reading comprehension task. However, unlike the case in L1, the benefit of topic familiarity for an L2 reading task was shown in those with high WM rather than those with low WM, which was proposed to be a function of task difficulty in Lesser's (2007) study. Despite this delicate difference in the impact of background knowledge between L1 and L2 reading tasks, a general pattern of findings of such studies still supports that LT-WM, which is mediated mostly by a quantity and a quality of background knowledge in LTM, makes a significantly independent contribution to reading comprehension. The text inferencing component in the four-component model by Hanon and Daneman (2001; 2006) was suggested to be a measure of LT-WM since it was found to share most variances with WM and it entails the combined use of text memory and knowledge access.

Table 2.2 Summary of Major Studies in WM and Reading

2.4.1. General Construct of WM				
	Focus of the study	Variables	Analysis Tech.	Results
Swanson and Howell (2001)	<ul style="list-style-type: none"> . The multi-component model of WM . 100 4th and 9th grade students 	Predictors: <ul style="list-style-type: none"> . Verbal WM: (1) RST* and (2) Auditory Digit Sequencing . Visual-spatial WM Outcome Variables: <ul style="list-style-type: none"> . Reading Comprehension . Word Recognition Task 	Hierarchical regression analyses	<ul style="list-style-type: none"> . The verbal WM showed a significant contribution to reading comprehension and word recognition after partialling out the effects of articulation speed and short-term memory. . The effect of visual-spatial WM disappeared when entered after the verbal WM. . The shared variance between verbal and visual-spatial WM is proposed to be a function of central executive. . Phonological loop, visual-spatial, and central executive are independent constructs.
2.4.2. WM and L1 and L2 Reading				
	Focus of the study	Variables	Analysis Tech.	Results
Cain, Oakhill, & Bryant (2004)	<ul style="list-style-type: none"> . Relations between L1 reading and WM . 102 seven-eight year olds at three time points (8th, 9th, 11th years) 	Predictors: <ul style="list-style-type: none"> . WM measures: RST (reading span task), and digit span task . Component comprehension skills . Verbal IQ . Various voc. measures Outcome Variables: <ul style="list-style-type: none"> . Neal Reading Comprehension 	Fixed-order hierarchical multiple regression analysis at three time points	<ul style="list-style-type: none"> . WM explained significant variances in reading comprehension above and beyond the contribution made by the other variables at three time points. . RST was more highly correlated with reading comprehension and component comprehension skills than digit span task. . Significant correlations between RST and digit span task were observed at each time point. . Phonological loop alone does not explain significant variances for reading comprehension.
Harrington & Sawyer (1992)	<ul style="list-style-type: none"> . Relations between L2 reading and WM . 35 Japanese college students 	<ul style="list-style-type: none"> . WM: RST, word span, and digit span in Japanese and English . TOEFL grammar and reading 	Correlation analysis	<ul style="list-style-type: none"> . English RST and Japanese RST were significantly correlated at .05, where English digit span and Japanese digit span were significantly correlated at .01. . English RST and TOEFL reading were significantly correlated.
Osaka, Nishizaki, & Komori (2002)	<ul style="list-style-type: none"> . Central executive as attentional control in RST 	Independent Variables: <ul style="list-style-type: none"> . Focused vs. Nonfocused . High vs. Low WM Dependent	ANOVA	<ul style="list-style-type: none"> . RST span scores were higher for the focused RST than for the nonfocused RST. . Intrusion errors were found to increase for the nonfocused RST. . Low-span Ss were more

		Variable: <ul style="list-style-type: none"> . Intrusion errors . RST scores 		<ul style="list-style-type: none"> affected than were high-span Ss by whether the word to be remembered was the focus word. . The low-span Ss had deficits in their ability to establish and/or inhibit mental focus when faced with conflict situations in reading.
2.4.3. Episodic Buffer and LT-WM				
	Focus of the study	Variables	Analysis Tech.	Results
Miller, Cohen, & Wingfield (2006)	<ul style="list-style-type: none"> . Role of contextual knowledge . Individual differences in WM . 200 adults 	Independent Variables: <ul style="list-style-type: none"> . Title vs. No title . High vs. Low WM (RST) Dependent Variable: <ul style="list-style-type: none"> . Reading efficiency 	ANOVA	<ul style="list-style-type: none"> . Significant main effects of WM on reading efficiency were observed. . WM was more important for those in the no title condition. . The compensatory function of WM and background knowledge for reading comprehension was confirmed.
Lesser (2007)	<ul style="list-style-type: none"> . Topic familiarity in L2 reading and WM . 94 college students 	Independent Variables: <ul style="list-style-type: none"> . WM . Topic familiarity Dependent Variables: <ul style="list-style-type: none"> . Comprehension recall 	ANOVA	<ul style="list-style-type: none"> . Significant main effects of topic familiarity were found. . High WM recalled a greater percentage of text propositions than low WM. . The higher WM groups with a familiar topic outperformed all other groups regardless of WM.
Hannon & Daneman (2001)	<ul style="list-style-type: none"> . Four-component model for reading vs. WM. 	Variables: <ul style="list-style-type: none"> . Text inferencing . Speed . High-knowledge integration . WM . Reading comprehension 	Stepwise regression analysis	<ul style="list-style-type: none"> . WM as the first predictor explained 21 % of the total variances in reading comprehension, and text inferencing, speed, and high-knowledge integration accounted for 29%. . When WM was entered as the last predictor, text inferencing explained 23% of the variance, speed, 13%, high-knowledge integration, 11%, and WM only 3%. . WM tasks share most variance in common with the text inferencing component because text inferencing is the component whose predictive power is most reduced by entering WM as the first predictor.

The review on the role of memory in reading (the summary table of the important studies is given in the next page) has shed light on the cognitive conditions

under which readers are placed. Such conditions are characterized with limited resources or constraints upon the task of on-line reading. The following section will explicate instructional scaffolding in a perspective of cognitive load to be imposed via materials and pedagogical activities.

2.5 Theory for Instruction: Cognitive Load Theory (CLT)

CLT is a theoretical framework that investigates cognitive processes and instructional designs by simultaneously considering the structure of information and the cognitive architecture that allows learners to process that information (Pass, Renkl, & Sweller, 2003). According to Pollock et al. (2002), the theory assumes: (1) a limited WM that can process only a few elements of current information at any given time (Miller, 1956); (2) an effectively unlimited LTM holding knowledge that can be used to overcome the limitations of WM (Ericsson & Kintsch, 1995); (3) schemas (Larkin, McDermott, Simon, & Simon, 1980; Chi, Glaser, & Rees, 1982), held in LTM and used to structure knowledge by arranging lower order schemas into higher order schemas that require less WM capacity; and (4) automation that allows schemas to be processed automatically rather than consciously in WM thus reducing WM load (Schneider & Shiffrin, 1977; Shiffrin & Schneider, 1977; Kotovsky, Hayes, & Simon, 1985). Van Merriënboer and Sweller (2005) explained that WM load may be affected either by the intrinsic nature of the learning tasks themselves (intrinsic cognitive load) or by the manner in which the tasks are presented (extraneous cognitive load and germane cognitive load). They explained that intrinsic cognitive load is determined by the interaction between the nature of the materials being

learned and the expertise of the learner and is not alterable by instruction interventions. Extraneous cognitive load is caused when the manner in which information is presented to learners and the learning activities required of learners imposes an unnecessary cognitive load, interfering with new schema acquisition and automation (Pass et al. 2003). The germane cognitive load is equivalent to extraneous cognitive load but facilitative to learning because it promotes schema acquisition and automation (Pass et al. 2003). The three cognitive load types are additive in that together, the total load cannot exceed the WM resources available if learning is to occur (Pass et al. 2003).

One more concept or term to be included is element interactivity, with which the nature of materials to be learned is evaluated. According to Pass et al. (2003), information varies on a continuum from low to high in element interactivity. Each element of low-element interactivity material can be understood and learned individually without consideration of any other elements, whereas the elements of high-element interactivity material can be learned individually, but cannot be understood until all of the elements and their interactions are processed simultaneously (Pass et al., 2003). Van Merriënboer and Sweller (2005) reported the result of the earlier studies on cognitive load theory showing that instruction designed to decrease extraneous cognitive load has negligible effects on learning if element interactivity is low; however, such instruction positively affects learning and transfer performance for complex materials with a high level of element interactivity (Sweller and Chandler, 1994; Marcus, Cooper, & Sweller, 1996; Tindall-Ford, Chandler, & Sweller, 1997; Carlson, Chandler, & Sweller, 2003).

The nature of materials – L2 reading text – can be analyzed in terms of element interactivity. To recall the Construction Integration (CI) model, building textbase was proposed to be a function of L2 proficiency and situation model as L1 competence. The construction of textbase requires processing word recognition and word integration. Word recognition can take place at the level of low element interactivity because the process of recognizing a word itself does not require readers to incorporate the interpretation of words around it unless the word to be recognized has multiple meanings, which requires readers to find cues in its surrounding context; for example, to interpret “bank” as a financial institute rather than a river bank, readers need associated semantic cues such as “deposit” or “money” in a context.

However, a word integration process or parsing involves activating multiple pieces of knowledge about various syntactic rules simultaneously. Readers need to identify word categories such as nouns, verbs, adjectives, and adverbs, draw semantic boundaries among them at phrase and clause levels, perceive their roles in a given sentence – agents of verbs, receivers of verbs, or modifying elements –, and combine these various activated rules into a coherent mental representation. For example, to integrate words in the following sentence, “*After she broke up with her boy friend, Jane went to have her hair dyed,*” readers should be able to identify that *after* is a subordinate conjunction indicating the time that leads one clause, “*she broke up with her boy friend,*” that the agent of *broke up with* is *she*, who is Jane, that *her boy friend* is a receiver of *broke up with*, that *Jane* is an agent of the verb *went* and also infinitive *to have*, that *her hair* is a receiver of the verb *dye*, that the agent of *dye* is not known, and that the two verbs, *broke* and *went* had past tense, no matter how

explicit or implicit this knowledge is in readers' mind. This word integration process is qualified as elements of high-element interactivity material which can be learned individually, but cannot be understood until all of the elements and their interactions are processed simultaneously. Since this word integration process is involved in every level of comprehension in L2 reading, it is a highly challenging work that necessitates meticulous instructional designs.

This concept is also relevant to explaining differential impact of vocabulary knowledge and schematic knowledge on L2 reading comprehension. The knowledge of vocabulary is beneficial when building local, lower-level micro-propositions (bottom-up), which reflects a nature of low-element interactivity. On the other hand, forming macrostructures such as summarizing requires readers to understand details of a text hierarchically based on their degree of generality, which can be drawn after the comprehension of the whole text; therefore, it reflects a nature of high-element interactivity. Since processing materials with high-element interactivity is expected to consume more cognitive load than processing materials with low-element interactivity, providing schematic knowledge about a text at an instructional treatment level would have a greater beneficial impact on reading than providing vocabulary knowledge in general. However, in the case of L2 reading, the bottleneck effect of linguistic knowledge needs to be considered; the differential effects of these two treatments in L2 reading may not be as clear as in L1 reading and needs to be studied. To sum up, the concept of interactivity of materials makes it easier to see the nature or difficulty of cognitive processes involved in certain tasks, which would in turn be

facilitative to designing materials and manipulating various instructional activities accordingly.

2.6 The Foci of the Study

2.6.1 Cognitive Load Theory (CLT) and Advance Organizers

Out of many possible instructional interventions within CLT framework, an advance organizer seems to be one of the promising tools because it can spread a heavy cognitive load imposed for an L2 reading task over two phases, an advance organizer and a main text. Even though CLT does not directly explain the effect of advance organizer in an instructional setting, it emphasizes instructional manipulations that make cognitive load to be taxed stay at a manageable level of WM. Concerning the question, “what can be done if even after the removal of all sources of extraneous cognitive load, the element interactivity of the material is still too high to allow learning,” van Merriënboer and Sweller (2005) suggested manipulating the organization of instructional texts, which will affect the allocation of cognitive capacity (e.g., Britton and Glynn, 1982).

Pollock et al. (2002) studied the effects of the “isolated elements” procedure for learning a material with high-element interactivity. Based on the assumption that “some material which is high in element interactivity cannot be processed simultaneously in WM with understanding until after it has been stored in a schematic form in LTM” (p.82), they presented the materials in a serial manner by isolating some processing elements. As they hypothesized, understanding was lower in the first phase of instruction when elements were presented in isolation, but this

deficiency was compensated in the second phase when the full set of interacting elements was presented. An interesting finding was that for novice learners, the isolated-interacting elements method was superior to the interacting elements only method, while learners who had completed more courses in the subject area performed equivalently in both conditions. They interpreted the result as an indication that “the isolated-interacting elements method of instruction, which allows schema acquisition in order to facilitate learning and understanding, would be of little use to learners who already possess rudimentary schemas and so may not experience a heavy cognitive load” (p. 83). Thus, the progressive method of presentation appears to be an appropriate technique to use for novice learners who are confronted with highly complex materials but who lack the rudimentary schemata for dealing with those materials (van Merriënboer & Sweller, 2005).

The assumption and the finding of the Pollock et al study (2002) are consistent with the rationale for the use of advance organizer because the advance organizer is expected not only to distribute cognitive load over two instructional phases but also to function as schemata that facilitate the organization of the new knowledge under limited WM constraints. Ausubel (1960) first introduced advance organizers as a vehicle for testing his cognitive subsumption hypothesis: meaningful learning from prose involves subsuming new material under relevant existing concepts. It is assumed that advance organizers provide not only relevant prerequisite knowledge (subsumers that bear a superordinate relationship to the new materials; Mayer, 1987) but also information that enhances the “discriminability” between new

and existing concepts that are essentially different but confusingly similar during the learning task (Ausubel, 1968; Corkhill, 1992).

Therefore, the review of the studies on advance organizers, even though quite old, is deemed to be relevant. Since numerous studies were conducted on this topic, several meta-analyses were also published. Luiten, Ames, and Ackerson (1980) found a small, facilitative effect of advance organizers for both learning and retention; they performed a meta-analysis of 135 advance organizer studies using Glass's technique, which involves treatment effects that are quantified, standardized, and compared using the "effect size" statistic (cited in Langan-Fox, Waycott, & Albert, 2000). Stone (1983) concluded that overall, advance organizers were associated with increased learning and retention. Corkhill (1992) also reported that 24 of 29 experiments found facilitative effects of advance organizers (cited in Langan-Fox, Waycott, & Albert, 2000). However, Clark and Bean (1982) pointed out that the absence of definitions or objective descriptions and poor control over advance organizer derivation and construction blurred the overall positive effect of advance organizers in the studies. A newly suggested definition of advance organizers was made by Mayer and Bromage (1980), advance organizers as a stimulus that 1) is presented before learning, and 2) contains a system for logically organizing the information into a unified structure. In an attempt to build a better taxonomy of advance organizer characteristics for uniformity to be established, Robinson and Kiewra (1995) proposed two representative advance organizers, which are linear advance organizers and graphic advance organizers. Since this study

adopts a graphic advance organizer, the review of the studies will be focused on this area.

Waller (1981) proposed '*visual argument*' that a spatial arrangement of words rather than normal text language transmits the relations among ideas. In line with this view, Langan-Fox, Waycott, and Albert (2000) explained that an outline uses visual argument to communicate hierarchical concept relations better than text, and a graphic organizer uses visual argument to communicate hierarchical relations better than text and to communicate coordinate concept relations better than both outlines and text. Robinson and Kiewra (1995) conducted two experimental studies on the differential effects of graphic and outline organizers with college students and found that a set of graphic organizers is more effective than a set of informationally equivalent outlines or the text alone for learning. Townsend and Clarihew (1989) also found in the study with subjects whose ages ranged from 7 to 10 that those with weak prior knowledge gained significantly greater comprehension in a prose-reading task when graphics were added to a text advance organizer.

Langan-Fox et al. (2000) argued that these enhancement effects of graphic organizers have been interpreted in terms of dual coding (Paivio, 1986) or conjoint processing theories (Kulhavy, Lee, & Caterino, 1985). According to these theories, humans possess two distinct information-processing systems; one that represents information verbally, which is equivalent to the phonological loop in a WM framework, and the other that represents information spatially, which corresponds to visual-spatial sketch pad in a WM framework. Therefore, simultaneously processing information using the two modes can result in an additive effect on learning to occur

(Paivio, 1986). Based on this theory, Robinson, Robinson, and Katayama (1999) investigated the interactions of texts, outlines, graphic organizers and concept maps with the verbal and spatial concurrent tasks. The subjects of 31 college students were given a different kind of advance organizers (a text, an outline, a graphic organizer, or a concept map) for 1 minute, and then later were presented with either a verbal (digits) or spatial (dots) display for 5 seconds. They reported that students were able to retrieve information from memory most successfully when the two displays being concurrently maintained in WM were different, specifically, when students viewed texts or outlines, they were able to retrieve that information best when the concurrent memory display was spatial rather than verbal, and vice versa. Therefore, the effect of the graphic organizer of text structure before the verbal activity is more likely to get maximized and continue to be effective during L2 reading.

2.6.2 Vocabulary Knowledge and Schematic Knowledge

Vocabulary knowledge and grammatical skills that Bossers (1991) and Brisbois (1995) included in their analysis under L2 linguistic knowledge are explained in the CI model via word recognition and integration or parsing, both of which are related to building textbase. One of the advantages of using the CI model to explain L2 reading process is that it distinguishes textbase, which is explained largely by linguistic knowledge, from a situation model, which is explained roughly by an amount and a quality of background knowledge and general cognitive abilities to associate this knowledge in LTM with the textbase. When L2 readers are strong readers in their native language, they are expected to be able to use the same skills in L2 reading (resources for a situation model) because they are transferable; the

findings reviewed provided evidence for linguistic interdependence hypothesis when they pass a threshold level of L2 language proficiency even though it is not clear when this threshold effect disappears. The greatest benefit of using the CI model for L2 reading is that it concretizes the role of L1 reading by exploring a situation model, and it clarifies how L1 reading competence is connected with L2 reading comprehension by investigating the relationships between a textbase and a situation model. As the model has analyzed, building a situation model involves complex cognitive processes such as searching, evaluating, and integrating information in readers' LTM and inferencing, all of which have their own contribution to reading.

Even though all of the components both in a situation model and textbase deserve full attention on their own right, the present paper focuses on investigating some variables from each area within the CI framework; how vocabulary knowledge (word recognition) for textbase and schematic knowledge for a situation model contribute to L2 reading comprehension to a different degree, and how L1 reading competence and L2 proficiency are related to these cognitive processes. To understand the differential impact of vocabulary knowledge and schematic knowledge, we need to consider the processing characteristics of these types of knowledge because they show an interesting contrast; the processing of vocabulary knowledge is bottom-up, whereas the processing of schematic knowledge is top-down.

Vocabulary knowledge is a basic building block for constructing a mental representation of a text. A comprehension process is initiated with word recognition, which is integrated with surrounding words, forming a microstructure, the "local

structure of the text, the sentence-by-sentence information, as supplemented by and integrated with LTM information” (Kintsch, 1998, p. 50). When these microstructures that have formed over a series of cycles as shown in the four figures (Figure 1.1-1.4) are hierarchically arranged based on their generality at different levels, a macrostructure is generated, with which readers construct a coherent mental representation of the text. Since the building of a mental model begins from local or lower-level processing, which is word recognition, it is a bottom-up process.

On the other hand, the manner that schematic knowledge works is an example of top-down. In explaining a situation model, Kintsch (2005) described the role of memory or a knowledge component in LTM as “a kind of filter that facilitates expected sensations and inhibits the unexpected and unwanted” (p. 126). Even though knowledge can be activated promiscuously and bottom-up, he explained that activated systematic knowledge or schema functions as control units and serves as a powerful determinant of how additional sentences to be interpreted. One example of schematic information that could be useful for reading is knowledge about a text structure, generally called rhetorical patterns. Knowledge about rhetorical patterns such as topical net, hierarchy, cause-effect, compare-contrast, and a list (Chambliss and Calfee, 1998) can facilitate and guide readers to map new information (words and propositions) into a coherent mental representation in a way that the text presents. That is, knowledge about various text structures represented mostly through signal words will help readers identify a specific structure used in a given text and will orient their comprehension in a direction consistent with the structure identified;

readers do not have to spend their cognitive resources on constructing the structure from scratch on their own.

In addition, when L2 readers have a knowledge repertoire of various text structures (or patterns of relationship) and are able to identify a specific structure for a given text, they are more likely to make correct inferences on gaps or holes in relationships among words and propositions coming from the lack of linguistic knowledge; there is room for incomplete linguistic knowledge or partially built textbase information to be compensated for by an expectation driven process to some degree. Two cognitive processes that are at work in this process are integrating (or instantiation) and inferencing. Integrating is required in that new information in a text should be incorporated within a framework of an identified text structure. Inferencing is also needed because gaps in meanings caused by incomplete textbase should be interpreted within the same corresponding structure. Based on the aforementioned rationale, it is reasoned that schematic knowledge of text structures, which is a top-down process, would guide comprehension while vocabulary knowledge, which plays a critical role in a bottom-up process, would constrain comprehension.

There are two aspects that are unique about L2 vocabulary knowledge as opposed to L1 vocabulary knowledge. Due to the lack of input in terms of both quantity and quality, semantic, syntactic, and morphological specifications about a word that L2 readers extract and create are not as complete as those L1 readers do (Jiang, 2000) even if L2 readers retrieve or activate such information while reading an L2 text. In addition, “the presence of an established conceptual/semantic system with

an L1 lexical system [is] closely associated [with L2 vocabulary acquisition]” (Jiang, 2000, p. 49). Thus, “it is very unlikely that a new concept, or a set of new semantic specifications, will be created in the process because corresponding, or at least similar, concepts or semantic specifications already exist in the learner’s semantic system” (Jiang, 2000, p. 50). Depending on the concreteness or abstractness of words and how well abstract information represented in one’s L1 matches that in L2, mental representations that L2 readers build may differ at both levels of a textbase and a situation model.

Schematic knowledge can also vary across various cultures. The elaboration on this aspect is beyond the scope of the present study because it involves different kinds of schematic knowledge in all aspects of culture, which can be defined at different grain-sizes. The present study uses a science text to test the effect of schematic knowledge because knowledge of science is considered more stable across different cultures. That is, the interpretations on the terms, ‘photosynthesis’ or ‘respiration’ do not differ across different cultures. It is likely that the processes and the components involved in these scientific concepts tend to be uniform in the U.S. and Korea. The schematic knowledge used in the present study is thus defined as the processes and the components involved in ‘photosynthesis’ and ‘respiration’ that can make expectation-driven comprehension possible; the lack of linguistic knowledge can be compensated for by the presence of schematic knowledge.

2.6.3 Relationship Between L1 Reading Competence and L2 Proficiency

As explicated in the general framework of the CI model and its application to L2 reading, textbase should be elaborated with readers’ background knowledge in

order for them to come up with rich situation model or deep understanding of the text. When the text is readers' L1, it is assumed that vocabulary knowledge and syntactic/grammatical knowledge (or word recognition and word integration) of the text is activated automatically with little effort, where few individual differences are expected to be observed due to ceiling effects. Thus, good L1 reading competence is likely to be a function of situation model in readers' L1. The building of situation model involves activating informational resources or background knowledge in a reader's LTM relevant to the contents in a given text and ideally speaking, guiding comprehension, serving as a good resource for LT-WM or a good retrieval structure during reading. It also includes strategic problem solving skills that utilize contextual clues in the text as well as manipulate external contexts for additional aide – for example, searching the internet or encyclopedia. That is, differences in L1 reading competence are accounted for by a varied amount and quality of background knowledge, in abilities to evaluate, activate and instantiate relevant background knowledge to a given textbase, and in capacities to adopt appropriate problem solving strategies.

Based on the studies (Bossers, 1991; Carrell, 1991; Bernhardt and Kamil, 1995; and Brisbois, 1995) that specifically investigated the Linguistic Interdependence Hypothesis (Cummins, 1981), it is suggested that L1 readers with good abilities in the aforementioned areas are likely to be good L2 readers as well once they have reached a certain level of L2 proficiency. Specifically, this L1 reading competence, whose individual differences are likely to be shown in an ability to build situation model, is expected to be a significant predictor for L2 reading

comprehension at a more advanced level of L2 proficiency. However, seemingly at odds are the findings on the use of L1 during L2 reading that the better the L1 proficiency, the more thinking takes place in L2, the less use of L1 in thinking is observed (Leontiev, 1981; Cohen, 1998; Guerrero, 2005). This ostensibly contradictory observation can be indirectly addressed by the studies on bilingual lexical representation.

Raney et al. (2002) in their review on the Hierarchical Model of bilingual lexical representation explained that the strength of the lexical-to-conceptual links differs in L1 and L2. According to them, the strength of the links between L2 words and their meanings increases as L2 proficiency increases even though these links are weak in the initial stage. That is, those with lower L2 proficiency activate the meanings of words in their L1 because of the strong lexical-to-conceptual links in L1 and the weak links in L2, which in turn brings about thinking in L1 during L2 reading. As the proficiency improves, the strong lexical-to-conceptual links in L2 makes it possible for L2 readers to think in L2 without much mediation of L1 translation because conceptual information is now mapped in L2 directly.

What can be inferred from the studies on bilingual lexical representation and those on the Linguistic Interdependence Hypothesis is that more proficient L2 readers can activate L1 schematic/conceptual resources directly into the mental space of L2 without any mediating process of L1 use, thus thinking in L2. Despite the decreased use of L1 in a more advanced level of proficiency, what is transferred is the very same underlying competence to manipulate conceptual information, which is explained by an ability to build situation model. The increased L2 proficiency now

makes it possible for L2 readers to manipulate conceptual information directly in their L2, which brings about less thinking in L1. This may indicate that L2 readers now can transfer their ability to build a situation model in L1 into building situation model directly in L2. Thus, the path through which L1 reading competence is transferred to L2 reading competence appears to be the situation model. This speculation is to be tested in the present study.

2.7 Hypotheses Drawn from the Literature Review

The problem posed in the introduction, treating L2 reading and L1 reading as unidimensional constructs rather than multivariate constructs, was addressed by identifying various cognitive processes involved within the framework of the CI model. L2 linguistic knowledge was proposed to be explained by the textbase, which requires word recognition and integration (parsing) processing and the automatized retrieval of two types of knowledge (vocabulary and grammar), whereas L1 reading competence was proposed to be accounted for by a situation model. The factors related to a situation model included the quantity and the quality of background knowledge relevant to the textbase, the activation and evaluation of an appropriate knowledge set from the LTM resources, its automatized retrieval, the integration of new information with the LTM resources, filling semantic gaps in the textbase by inferencing and the strategy use. LT-WM or episodic buffer was deemed to play a critical role in building situation model, whereas WM was assumed to show differential capacities to hold and process novel information in the text.

Within the framework of CLT for instructional applications, a task of reading texts in L2, which is linguistically and cognitively demanding, carries extremely high cognitive load. Under the assumption of limited WM in the cognitive load theory, it goes without saying that a meticulous instructional design that manipulates germane cognitive load and that excludes every possible extraneous cognitive load has to be developed in order to increase chances for ELLs (English language learners) to get exposed to as many reading texts as possible in a meaningful way. The nature of the materials to be learned in this setting requires learners to handle twofold processing mechanisms of linguistic data and informational data simultaneously. Two types of expertise contribute to the degree of intrinsic cognitive load; linguistic expertise on the L2 and informational expertise on the subject matter.

As discussed in the previous sections in details, the sense of difficulty that learners may feel about the task of reading in L2 is contingent on their vocabulary and grammar knowledge and the degree of automatization of this knowledge; how much of it and how much of the automatization of their existing schemata on L2 specific linguistic knowledge is available in the form of LTM while conducting on-line reading; especially, in the beginning stage of L2 development as supported by Linguistic Threshold Hypothesis. Note that the CI and the cognitive load theory claim that WM capacity is limited only to the novel information not to the pre-existing automated schemata. The latter component, informational expertise or background knowledge, also functions as a determining factor of the intrinsic cognitive load in the same way as the linguistic knowledge does. The more and the better subject matter knowledge or schemata the learners possess, the more

automatically these schemata are to be activated during reading, and the less WM resources are needed. The very ability to use these informational resources in LTM in order to build situation model has been suggested to account for L1 reading competence as well.

Based on the studies reviewed, two types of advance organizers are assumed to function as instructional intervention to help distribute cognitive loads over the two-step presentation phases, which would result in a manageable cognitive load for L2 readers. The first hypothesis to be drawn from this principle is that students with instructional interventions (vocabulary activity and schematic knowledge activity) would succeed in comprehending L2 reading texts significantly better than those without such interventions.

Hypothesis 1: *The comprehension of L2 reading texts will significantly improve when interventions of vocabulary knowledge acquisition or schematic knowledge acquisition are provided.*

The CI model for L2 reading comprehension posits that L2 vocabulary knowledge be related to the textbase, which explains L2 proficiency, whereas schematic knowledge be related to situation model, which accounts for L1 reading competence. Thus, L2 proficiency is predicted to significantly contribute to the acquisition of vocabulary knowledge, whereas L1 reading competence is predicted to significantly contribute to the acquisition of schematic knowledge. Even though how

these four variables are related to each other can be inferred not only from the proposed theory but also intuitively, it still needs an experimental confirmation.

Hypothesis 2: *The effect of L1 reading competence and L2 language proficiency will be different in the two treatment conditions:*

2.1: L1 reading competence will be a stronger predictor for the condition of a schematic knowledge activity.

2.2: L2 language proficiency will be a stronger predictor for the condition of a vocabulary knowledge activity.

The third hypothesis is to be investigated in relation to L1 reading competence. There would be no effect of different L1 reading competence in L2 reading comprehension in the control condition and pre-test conditions in two treatment groups. This hypothesis is induced from the rationale as to the role of task difficulty in relation to the effect of different WM capacities. It was explained in the WM section that in the case of a task with medium difficulty, which characterized the reading task adopted in Miller et al.'s study (2006), cognitive demand was manageable for readers of high WM without any support on background knowledge or title, whereas it was not manageable for readers of low WM until they were provided with such additional support. However, when the task is considerably difficult, which is the conditions that the readers have to process not only informational input but also linguistic input in the case of Lesser's study (2007), cognitive demand was so high that only those of high WM could benefit from

additional support of background knowledge. Those of low WM could not handle incoming input even with the additional help such as background knowledge due to too much cognitive demand in Lesser's study (2007).

Since the no-intervention condition or pre-test conditions present an L2 reading text without any additional scaffolding, where readers should deal with informational and linguistic challenges simultaneously without any additional help, the task of L2 reading in this condition would be too challenging to make use of L1 reading competence. Thus, individual differences in L1 reading competence would not make much difference in their subsequent comprehension under no-intervention and pre-test conditions. L2 readers would have to spend all the cognitive resources and attention on building textbase activating their limited linguistic knowledge.

Hypothesis 3: *The effect of different L1 reading competence upon L2 reading comprehension in the pretests for all conditions (one control condition and two treatment conditions) will be minimal due to the linguistic threshold or bottle neck effect.*

As noted in the earlier sections, different types of knowledge play a different role in comprehension: vocabulary knowledge plays a crucial role in building micropropositions that serve as a basis for textbase in a bottom-up manner, whereas well-organized schematic knowledge leads expectation-driven comprehension in a top-down manner. Since L2 reading is a task that requires the use of excessive cognitive load, it is highly likely that any type of scaffolding activities that help

reduce a processing burden of a given text would be of great value as addressed in the hypothesis one. For this reason, a reasonable pedagogical action would be to adopt both as instructional activities for ELLs. However, the extent to which these two types of knowledge with different processing features contribute to comprehension and whether each of them has a significant independent contribution to comprehension would give an insight into our understanding of cognitive processes involved in L2 reading in finer details. In turn, this would provide a framework for better aligning different instructional activities in class and a framework for diagnosis of the nature of L2 reading problems; whether failure of comprehension comes from the lack of vocabulary knowledge or the lack of schemata.

One distinctive feature of vocabulary knowledge as opposed to well-organized schematic knowledge is that it does not serve as a good retrieval structure for recall, whereas it facilitates bottom-up processing of L2 reading text. In this sense, this type of knowledge would be relatively of less assistance to the working of LT-WM, while it would be of great value to reducing WM in that a reader needs to handle only new informational input but not too much of new linguistic input. On the other hand, well-organized schematic knowledge not only elaborates textbase but also serves as a superior retrieval structure that would boost LT-WM to a great degree during reading, which would in turn spare more room for the function of WM. However, whether or not this knowledge would compensate for the lack of vocabulary knowledge successfully, and if so, to what extent, is a question to be explored. In other words, the question is whether or not schematic knowledge scaffolding, which is hypothesized to be closely tied with L1 reading competence,

could dilute the bottleneck effect of linguistic knowledge, for L2 reading comprehension. Thus, the fourth hypothesis is that there would be different effects of an intervention type upon comprehension, which would be shown through different kinds of measures; recall and multiple-choice and true/false questions.

Hypothesis 4: *There will be different effects of an intervention type upon comprehension, which will be shown in different reading comprehension measures and item types, such as multiple-choice and true/false questions and recall, as well as their related cognitive processes*

The last hypothesis to be investigated concerns the validity of the proposed theory, textbase as a function of L2 proficiency and situation model as a function of L1 reading competence to explain L2 reading comprehension. The selection of the two treatment conditions is based on what each treatment type is supposed to concern, vocabulary knowledge tapping into L2 proficiency and schematic knowledge into L1 reading competence. Clustering of these predictors as latent variables such as textbase and situation model has been tested in the second hypothesis. This validation process should be considered a somewhat partial investigation because not all the relevant predictors were included for each latent variable. A more complete set of predictors for textbase should include phonological knowledge, syntactic knowledge, and degrees of automatization of such knowledge as well as vocabulary knowledge for a given text in addition to general L2 proficiency. A more complete

set of predictors for the situation model should include a metacognitive ability and an inferencing ability as well as schematic knowledge. Even though the first two components are assumed to be tested in an L1 reading, finer-grained assessment on such competences respectively would provide a more accurate and thorough analysis. Despite this limitation, the selected predictors for each construct (a textbase and a situation model to explain L2 reading comprehension) in the present study can inform us of the viability of the CI model for L2 reading comprehension. The indicators for a situation model include L1 reading competence, measured by multiple-choice and true/false questions and a recall and schematic knowledge, and the indicators for a textbase include L2 proficiency (listening comprehension and reading comprehension) and vocabulary knowledge. Whether the textbase and the situation model operationalized with these indicators explains L2 reading comprehension will be examined through the hypothesis 5.

Hypothesis 5: *A textbase, or a mental representation of elements and relations directly derived from the text itself, (indicators include L2 proficiency and vocabulary knowledge) and a situation model, or propositions elaborated by background knowledge, (indicators include L1 reading competence and schematic knowledge) will successfully explain L2 reading comprehension.*

Chapter 3: Method

Chapter Three provides detailed descriptions of the characteristics of the participants relevant to the selection criteria, a rationale for selecting texts used in the present study, how intervention was given, kinds of instruments used to measure L1 reading competence, L2 proficiency, L2 reading comprehension, and treatment effects, and the description on a four-day-long implementation of the study. The administration procedures are provided in Table 3.1.

3.1 Participants

The selection of the target population is codetermined with the difficulty of L2 reading materials linguistically and informationally. Since the focus of the study is to see the effect of acquiring vocabulary and schematic knowledge directly extracted from the reading passages upon the subsequent comprehension of the texts that the participants are going to read, it should be secured that a sufficient amount of unfamiliar vocabulary is present in the text and the information presented via texts should be unfamiliar to some degree. With these constraints in mind, the target population of the study is chosen to be Korean 9th grade students in Korea. 9th grade students in Korea have studied English for six years. English class was assigned one class period (forty minutes) per week in 3rd and 4th grades, two class periods per week in 5th and 6th grades, and four class periods (forty five minutes of one class period) per week in 7th, 8th, and 9th grades in the Korean public education system. To give a sense of the English proficiency that 9th graders in Korea could develop in reading, the learning standards for the area of English reading laid out by KICE (Korea

Table 3.1 Administration of procedures

Time	1 st Day	2 nd Day	3 rd Day	4 th Day
9:00-9:50	Administration of TOEIC Bridge	Pretest (photosynthesis or respiration)	Pretest (photosynthesis or respiration)	Pretest (cancer)
9:50-10:00		BREAK	BREAK	BREAK
10:00-10:50		Treatment & Quiz	Treatment & Quiz	Korean Reading Test (blood circulation and lymph)
10:50-11:00		BREAK	BREAK	BREAK
11:00-11:50		Posttest (photosynthesis or respiration)	Posttest (photosynthesis or respiration)	Posttest (cancer)

Institute for Curriculum and Evaluation, <http://www.kice.re.kr/index.do>) are translated into English and given in Table 3.2.

Thirty-two participants from three middle schools in Taejeon, Korea participated in the study; six participants from Dongdaejjeon middle school, sixteen participants from Wallpyung middle school, and ten participants from Donghwah middle school. The student researcher contacted many middle schools in Taejeon, Korea by phone over the spring semester, 2009, and received confirmation of the participation from the three schools. The schools made an announcement to their 9th grade students concerning the study with basic information on the procedures of the study. The compensation for participating in the study, taking the TOEIC Bridge for free, was also announced. One teacher from each school helped recruiting students and implementing the study (contacting the students to participate in the study because the study was conducted during the summer vacation, 2009).

The expected sample size (the number of participants that teachers from each school informed the student researcher for the recruited students) prior to the study

Table 3.2 Learning standards of English reading for 9th graders in Korea

	Stage a	Stage b
S1	<p>Be able to read passages about general topics and be able to figure out main ideas and details.</p> <p><example> Read the following paragraph and summarize.</p> <p><i>Many sings in nature tell you when winter is coming. Wild animals begin to store food. Their fur grows thicker and longer. The leaves on the trees die and fall to ground. Many birds fly south.</i></p>	<p>Be able to read passages about general topics and be able to identify a main idea and a conclusion.</p> <p><example> Read the paragraph given below and choose the correct answer that fits the blank best.</p> <p><i>My arrival at the village created some excitement; I was no longer regarded as a friend or one of the family. Runi was absent, and I looked forward to his return with no great pleasure; he would doubtless decide my fate.</i> The writer was _____</p> <p>a. afraid of Runi's return b. pleased that Runi would return c. looking forward to meeting Runi d. sad that Runi was gone</p>
S2	<p>Be able to read passages about general topics and be able to summarize.</p> <p><example> Read the following paragraph and summarize.</p> <p><i>Many sings in nature tell you when winter is coming. Wild animals begin to store food. Their fur grows thicker and longer. The leaves on the trees die and fall to ground. Many birds fly south.</i></p>	<p>Be able to read passages about general topics, be able to understand a cause and effect relationship, and be able to identify a rationale for such relationships.</p>
S3	<p>Be able to read passages about general topics and be able to understand author's perspective.</p>	<p>Be able to read passages about general topics and be able to understand author's intention of the writing and perspective.</p>
S4	<p>Be able to comprehend general ideas and be able to extract important information based on given contexts.</p>	<p>Be able to understand the flow of ideas and logical structure embedded in passages about general topics.</p> <p><example> Number each sentence based on the logical flow and indicate topic sentence as TS.</p> <ul style="list-style-type: none"> . They were bored seeing the same old people and doing the same old things. . Larry and Patrick were tried from doing chores and homework. . It had been a long hard weeks, both at home and at school. . They could relax, see new things, and meet new people. . Larry and Patrick decided to go camping this weekend.

S5	Be able to read passages about general topics and be able to discriminate information based on relevance to the given topics.	Be able to read passages about general topics and be able to predict what comes next. <example> Read the following paragraph and choose the item that fits the blank best. Many New Yorkers prefer to live in tall apartment buildings. Everyone wants the apartments near the top. So these are usually _____ a. Empty b. The most expensive c. The least expensive d. The last ones to be rented
S6	Be able to read sentence slips and be able to arrange them according to chronological order. <example> Rearrange the sentences in a way that reflects a chronological order. . <i>Steps in Writing a Report</i> . <i>Edit the draft and correct any errors in your spelling or grammar.</i> . <i>Select a topic to write about.</i> . <i>Write a first draft.</i> . <i>Copy the report over in final form.</i> . <i>Decide what facts of ideas you want to mention about the topic.</i>	Be able to read passages about general topics and be able to predict a conclusion. <example> Read the following paragraph and choose the item that fits the blank the best. Young children in one town have no trouble in finding the right school bus. Each bus has a picture of a familiar animal. Children going to another school look for the Mickey Mouse bus. Children going to another school look for the Yogi Bear bus. Q : You can tell that young children _____ a. do not like school b. do not have trouble reading signs
S7	Be able to read passages about general topics and be able to identify logical connections among sentences.	Be able to read commercials and be able to distinguish factual from imaginary contents.

was sixty-two, which exceeded the recommended sample size by G-Power (44 participants for effect size of .25, . power of .95, an alpha level of .05, and three repetitions with ANOVA: repeated measures, within factors). However, thirty-two out of forty-five students who took the TOEIC Bridge on the first day participated in the whole process of the study (six students from Dongdaejon, twenty four from Wallpyung, and fifteen from Donghwah); seventeen students who signed up for the

participation in the study did not show up when the study was conducted. Those with missing data were excluded from the analysis.

3.2 Reading Text

Three English texts (517, 530, and 558 words) were extracted from the textbook, *Cells and Heredity*, which is used in American middle schools. The topics of the texts were '*photosynthesis*', '*respiration*', and '*cancer*.' The selection of the texts is based on the consideration of expected L2 proficiency and background knowledge for 9th grade students in Korea. In terms of informational demands, the complexity of the topic appears to be appropriate to the 9th grade students in Korea because the textbook from which three texts were extracted is currently used in middle schools in the U.S. and the participants are in middle school in Korea as well. It was determined that 9th grade students had already learned the topics in their curriculum, which was the case for '*photosynthesis*' and '*respiration*;' these topics were covered in 7th grade and 8th grade respectively in the Korean curriculum (<http://ncic.kice.re.kr/nation.dwn.ogf.inventoryList.do>). Based on the information, the participants were anticipated to have some knowledge in the topics but not vivid memory because the topics were covered in the previous years of the curriculum. This created an ideal condition for the topical complexity of the texts to be used. However, since curricular coverage does not guarantee learning of the materials, the aforementioned speculation about the participants' knowledge stage on the given topics needs to be supported by empirical data. This was indeed confirmed by the scores on the schematic knowledge activity. The graphic representation of the texts

on the topic of *photosynthesis* and *respiration* was designed to be so condensed that readers with little understanding of the contents would not be likely to obtain high scores even after reading the text and the schematic knowledge activity. The mean score of the 32 participants was 32.19 out of 40 with 7.78 SD and negative skewness.

As far as the linguistic complexity is concerned, science texts were chosen because they have relatively less complex syntactic structures than texts in language art or social science. The number of potential unfamiliar vocabulary (42 words for *photosynthesis* and 44 words for *respiration*) was deemed to be appropriate, which was confirmed by the scores of the quiz on the vocabulary acquisition activity. The scores of the quiz on the vocabulary knowledge were negatively skewed, which indicates that most of the students scored high in the test after the acquisition activity. The text for Korean reading comprehension was extracted from the biology textbook used in public high schools in Korea. '*Blood circulation*' covered the basic information on the circulation of the blood, whose topics are taught in middle school, and included new information on lymph. The combination of old and new information was intended to create a condition in which the demand on working memory can be optimized.

3.3 Treatment

1) Vocabulary activity. A list of vocabulary that was deemed to be unfamiliar for 9th grade students in Korea (42 words and 44 words for *photosynthesis* and *respiration* respectively) was drawn from each text. In order to ensure the feature of this treatment as a scaffolding activity at a bottom-up processing level, all the designated

vocabulary words for each text were alphabetized and presented in such an order. For the first five minutes, the vocabulary list was given with blanks so that the participants can check on what they already know about these words. During the second session (30 minutes), the same list of words was given along with an English definition and one English sentence containing each word in it. The translation of the example sentence was given except the meaning of the target word so that the participants could infer the meaning of the word. The Korean translation of each example sentence with the meaning of the word included was provided in the last page. After the acquisition activity, a quiz on the learned vocabulary was implemented for 15 minutes. The exact same list of vocabulary was given with blanks to be filled with Korean translation. Examples of the vocabulary activity materials are attached in appendix A.

2) Schematic knowledge activity. Graphic organizers that contain schematic information on the topics – *photosynthesis* and *respiration* – were designed. The graphic representation was given in English on the left column and its elaborated Korean translation on the right column. The presentation proceeded in four steps; the first one without any blanks, the second with some blanks, the third with more blanks, and the fourth with no missing information (the same as the first step). The participants were instructed to study the concept map and translation so that they can fill the blanks from their understanding and memory. Gradual change in the number of blanks was expected to make it possible for the participants to manage cognitive loads step by step. The whole study session was thirty-minute long. After this

interventional activity, a quiz (fifteen minutes) was given; the form presented on the third phase with most blanks was provided for the participants to fill the blanks (ten minutes). For the last five minutes, the participants were asked to answer one question in an essay format. Examples of graphic organizers are attached in appendix B.

3.4 Instruments

1) L1 reading competence.

A 406-word long text about '*blood circulation*' was extracted from a Korean biology textbook, used in high schools in Korea. Sixteen True/False questions and four multiple choice questions were developed. The concept was expected to be somewhat familiar but with new information on '*lymph*.' The familiar topic was covered in the curriculum that the target population had been in over their previous school years. The text on the new information (lymph) is 124 words long. Due to the combination of old information and new information, the cognitive complexity of the topic is deemed to be manageable enough for this population to learn by reading the text and to answer the questions.

2) L2 language proficiency:

One of the standardized tests of English relevant to the target population for the present study (9th grade) is TOEIC Bridge (a paper-and-pencil test). It is a test that was developed by Educational Testing Service (ETS) to measure emerging English-language competencies

(<http://www.ets.org/portal/site/ets/menuitem.435c0b5cc7bd0ae7015d9510c3921509/?>)

vgnextoid=d3637f95494f4010VgnVCM10000022f95190RCRD). It consists of five parts, which include photographs (15 questions) for listening, Question-Response (20 questions) for listening, Short Conversations and Short Talks (15 questions) for Listening, Incomplete Sentence for Reading (30 questions), and Reading Comprehension (30 questions). The total time required to complete the test is 60 minutes plus 30 minutes for completing the biographic questions and a brief questionnaire about their educational history. Detailed information on the test can be found at <http://www.ets.org/portal/site/ets/menuitem.1488512ecfd5b8849a77b13bc3921509/?vgnextoid=e5452d3631df4010VgnVCM10000022f95190RCRD&vgnnextchannel=c8a37f95494f4010VgnVCM10000022f95190RCRD>.

3) Measure of the Treatment Effect:

It has been proposed that two types of treatment would help participants comprehend linguistically and informationally difficult L2 reading texts. The treatment would be facilitative to the comprehension of the texts to the same extent as that to which participants understand materials in the treatment. In order to identify how well participants learn the materials in the treatment conditions and to ensure that the study yields more accurate evaluation of the effect of treatment upon the comprehension outcome, quizzes were given in each treatment condition after the acquisition activity; a quiz on vocabulary knowledge and a quiz on schematic knowledge at the end of the treatment session was given for fifteen minutes.

4) Reading Comprehension Measures:

Two types of comprehension measures were used: (1) a recall task and (2) multiple-choice questions and *T/F* questions. Each of the measures has its own characteristics in what they measure. A recall task can be easily seen as a task that tests text-memory only from a quantitative point of view because the total score is usually calculated as an aggregate of the number of propositions recalled from the text. However, this belies the nature of memory. As discussed in the memory section, WM deals with novel information, whereas LT-WM provides interface between incoming new information and existing information, and it has been suggested that it is LT-WM that makes it possible for readers to process and remember a considerable amount of information during the whole reading process. In this sense, those with better organized information are likely to recall more information from the text, and those with better abilities to make inferences and connect important propositions together are more likely to come up with better organization of the information. This makes a recall task a measure of quality disguised in quantity. That is, without any proper organization of the text that subsumes numerous small propositions or effective macropropositions, there will not be much information that can be recalled.

One important aspect to be considered is the number of propositions in a reading task to be recalled later. When a recall task is given after two or three-sentence reading, which may contain a few propositions and relatively shortly after the sentence reading, a text memory capacity would be the one tested mostly. However, when a reading text becomes a paragraph with a number of propositions, what is recalled becomes a function more of LT-WM resources, or a quality of

schematic knowledge rather than of mere text memory and readers' orientations for attending specific aspects of the reading (Bartlett, 1932, 1955).

Unlike a recall task, multiple-choice and true/false questions do not address a memory component of L2 reading comprehension to a great degree in the sense that readers are allowed to refer back to the main text and search for the answers or evaluate answer choices in relation to the questions given in the test. The questions in the multiple-choice and true/false tests were developed based on three characteristics of informational demand, which are text memory, low-level inference, and inference. Questions of text memory reflect direct textual information and thus require L2 readers to locate the portions that state the propositions related to a given question and evaluate the truthfulness of the statement. For example, "*The leaves are the only part through which plants obtain their energy from sunlight.*" can be answered by directly locating the statement in the main text, "*In plants, this energy-capturing process occurs in the leaves and other green parts of the plant.*" Since the answer can be found in a local area of the text in one sentence, it does not require much demand on cognitive processing when readers succeed in building a textbase of the sentence.

The questions of low-level inference ask readers to combine information that should be located among different sentences from the main text. For example, in order for L2 readers to evaluate the truthfulness of the following sentence, "*Every living thing uses the same mechanisms to gain energy for their living.*", they should read the entire paragraph of the following. "*Every living thing needs energy. All cells need energy to carry out their functions such as making proteins and transporting*

substances into and out of the cell. Your picnic lunch supplies your cells with the energy they need. But plants and other organisms, such as algae and some bacteria, obtain their energy in a different way. These organisms use the energy in sunlight to make their own food.” This type of question requires readers to successfully build a textbase of the whole paragraph and synthesize information in relation to the statement given in a question. Thus, more cognitive resources are taxed in this type of question than the questions of text memory.

The third type of question, inference is similar to the low-level inferencing in that it requires readers to synthesize information from a paragraph level. But the complexity of inferencing is more demanding than the questions of low-level inference; for example, evaluating the truthfulness of the statement, “*All organisms that carry out photosynthesis release oxygen.*” requires readers to locate two paragraphs in the main text and draw a conclusion about the statement in the question. The two paragraphs that should be read to answer the question correctly are given as following.

Using energy to make food: in the second stage of photosynthesis, the cell uses the captured energy to produce sugars. The cell needs two raw materials for this stage: water (H₂O) and carbon dioxide (CO₂). In plants, the roots absorb water from the soil. The water then moves up through the plant’s stem to the leaves. Carbon dioxide is one of the gases in the air. Carbon dioxide enters the plant through small openings on the undersides of the leaves called stomata. Once in the leaves, the water and carbon dioxide move into the chloroplasts.

Inside the chloroplasts, the water and carbon dioxide undergo a complex series of chemical reactions. The reactions are powered by the energy captured in the first stage. One of the products of the reactions is oxygen (O₂). The other products are sugars, including glucose; sugars are a type of carbohydrate. Cells can use the energy in the sugars to carry out important cell functions.

There are five text memory questions, nine low-level inference questions, and four inference questions in each test, (the tests of photosynthesis, respiration, and cancer). Thus, what is measured by multiple-choice and true/false questions is an ability to build textbase of a main text that has relevance to the questions and evaluate the information based on its truthfulness. Even though proficiency memory of the text can facilitate the process of finding a relevant piece of information and evaluate it in relation to the questions, the multiple-choice and true/false questions as opposed to a recall task tax abilities to construct more accurate textbase and evaluate different kinds of micropropositions.

3.5 Procedures

Since the study is a repeated measure design, all the participants went through three conditions in a counter-balanced manner. There were two components that had to be counter-balanced, a test form and a treatment type. The two test forms were perfectly counter-balanced; sixteen participants from Wallpyung were given '*photosynthesis*' first and '*respiration*' second, while six from Dongdaejjeon and ten from Donghwah were given '*respiration*' first and '*photosynthesis*' second. But for the order of

treatment type, eighteen participants received a schematic knowledge acquisition activity first and then a vocabulary knowledge acquisition activity, whereas fourteen participants received a vocabulary acquisition activity first and then a schematic knowledge acquisition activity. The procedures described below follows the chronological order.

The First Day: Administration of TOEIC Bridge

One staff from Sisa Inc., an ETS vendor in Korea came to each school (July, 14 in Wallpyung, July, 20 in Dongdaejjeon, and July, 27 in Dongwhah) to supervise the implementation of the test. The participants were given an instruction on the test in general and asked to fill out forms on the identification information. The test of listening comprehension was given in the first section for 25 minutes, consisting of fifteen questions on picture description, twenty on responses, and fifteen on conversation. Without any break, the reading comprehension section followed for 35 minutes. Thirty questions on grammar and vocabulary and twenty on reading comprehension were administered. When the test was finished, the staff from the Sisa Inc. collected the response sheets to score. The scores of the test were sent to the student researcher two weeks after the implementation of the test and to the students two month later by the Sisa Inc.

The Second Day and the Third Day: Treatment Conditions

The session consists of four phases: (1) pre-test (50 minutes), (2) treatment (35 minutes), (3) quiz on the treatment (15 minutes), and (4) post-test (50 minutes). Two

ten-minute breaks were given; one between phase one and phase two and the other between phase three and four. One class period is forty five minutes long in Korean middle schools. Time allotment of the sessions may be perceived somewhat challenging for 9th grade students since a block of fifty minutes is longer than a regular class period. However, the observation of the time that the participants spent on completing pre-tests and post-tests indicated that they had enough time to finish the tests and used the remaining time (five to ten minutes, depending on individuals) for rest. The participants were also provided with some snacks (cookies and drinks) during the two breaks.

The pre-test and the post-test have exactly the same format and the same time allotment except that during the post-tests, the participants were allowed to refer to the treatment materials, either a list of vocabulary with Korean translation or a concept map with Korean explanation (the materials from schematic knowledge activity were not allowed for recall task). Thus, the following description concerns the both tests. The participants were given a test set in a paper and pencil form. The first page asked the participants to write their name and email address and described the composition of the test and time allotment, which is *reading the whole text* (5 minutes), *recall* (5 minutes), *reading the first half of the text* (5 minutes), *recall* (5 minutes), *reading the other half of the text* (5 minutes), *recall* (5 minutes), and *answering fifteen true/false and three multiple-choice questions* (20 minutes). The participants were not allowed to go back to the previous section and go forward to the following section within the allotted time frame. The tests are attached in appendix C.

After the pre-test, either a vocabulary knowledge acquisition activity (VKAA) or a schematic knowledge acquisition activity (SKAA) was given for thirty minutes, followed by a fifteen-minute-long quiz on each treatment that the participants received. The VKAA condition began with the list of vocabulary with blanks that appeared in the pre-test; 42 words for *photosynthesis* and 44 words for *respiration*; the materials used for the vocabulary knowledge acquisition activity are found in Appendix A. The participants were asked to provide a Korean translation equivalent to the word in the list (five minutes). The purpose of this section was to raise students' awareness on what they already know and do not know. It was made clear in the direction that the participants did not need to feel any anxiety for not knowing many words because it was intended so. The next section provided a definition of the word from the Collins COBUILD dictionary, one example sentence in English, and Korean translation of the example sentence with the meaning of the target word substituted with a blank. All of the 42 words for *photosynthesis* and the 44 words for *respiration* followed the same format. The Korean translation of the example sentence with the Korean translation equivalent of the target word underlined was provided in the last page. The participants were asked to read the definitions and example sentences in English and to come up with a correct Korean translation of the target word. They were allowed to check the answer anytime they want during the treatment session. They were also informed that they would be given a quiz after the treatment activity. After the thirty-minute acquisition activity, the participants were given a quiz (15 minutes) on the learned vocabulary. Exactly the same list of the

vocabulary that appeared on the first page was given to be filled with equivalent Korean translation for each word.

The SKAA condition consists of four presentation stages. All the materials presented have the same format; a graphic representation (concept map) of the content in English on the left and Korean explanation of the graphic representation on the right; the materials used in the schematic knowledge acquisition activity are found in appendix B. The first stage (ten minutes) presented the material without any missing information so that the participants could study it thoroughly. The material in the second stage (ten minutes) had some blanks both in the concept map and its equivalent Korean translation. The participants were asked to fill the blanks out from their understanding and memory of the material. Since the activity was intended for learning, they were allowed to go back to the first page to check whether the information they came up with is correct or not. The third stage (ten minutes) presented the same material but with more blanks to be filled. The last stage (five minutes) provided the same material as the first stage, a graphic representation of the content in English on the left and Korean explanation of the map on the right with all the information filled. The directions were given in Korean and English translations are provided: the first stage, *“The graphic representation given below is the concept map of the reading passages that you’ve read. Study the graphic representation on the left along with Korean explanation as to the map on the right. In the following sections, you will be provided with the same material but with some information substituted with blanks. You will be asked to fill the blanks from your understanding.”*; the second and third stages, *“Fill out the blanks provided below. If*

you cannot remember, you can go back to the previous page.”; the fourth stage, “*Review the concept map and Korean explanation on it given below. After five minute of reviewing, you will be given a quiz, exactly the same material given in the third stage (the material with more blanks).* After the acquisition activity, the quiz was given for fifteen minutes; one that requires the participants to fill out the blanks (ten minutes) and the other that asks to answer the question concerning the text that they read (five minutes).

The Fourth Day: Control Condition and Korean Reading Test

The control condition has exactly the same format as the treatment conditions except that no treatment was given between the pre-test and post-test. Instead of any treatment activity and the quiz, a Korean reading test was administered. The Korean reading test has the same format as the treatment conditions except that there were no pre-, post-tests but only one test, and there were two more questions in the last section (one true/false question and one multiple-choice question). Thus, the composition of the test was *reading the whole text (5 minutes), recall (5 minutes), reading the first half of the text (5 minutes), recall (5 minutes), reading the other half of the text (5 minutes), recall (5 minutes), and answering fifteen true/false and three multiple-choice questions (20 minutes).*

Chapter 4: Results

Chapter Four begins with a description on scoring procedures for each measure. In order to reflect the multidimensionality of the constructs such as L1 reading competence, L2 proficiency, and L2 reading comprehension, SEM (Structural Equation Modeling) was used to analyze the collected data. Unlike the previous studies that used an aggregated score of multiple-choice questions to represent each construct, SEM analyzes covariance structures of important indicators to represent different latent constructs such as L1 reading competence, L2 proficiency, and L2 reading comprehension. The scores of L2 reading comprehension and the scores of L2 listening comprehension are used to predict a latent construct of L2 proficiency. Since the covariances between the scores of L2 reading comprehension and L2 listening comprehension are used to operationalize L2 proficiency, it is a more accurate representation of L2 proficiency than a total score of the two subskills. In order to conduct fine-grained levels of analysis of different cognitive processes that explain L1 reading comprehension and L2 reading comprehension, the scores of multiple-choice and true/false questions and the scores of a recall task are used as independent indicators for each construct (L1 reading competence and L2 reading competence). The reporting of the results is organized based on the tested hypotheses.

4.1 Scoring Procedure

All the data collected from the study include (1) the scores of TOEIC Bridge (LC and RC) as a measure of general L2 proficiency, (2) the two sets of scores of one Korean text (multiple-choice and true/false questions and recall data), and (3) the two sets of scores for three English texts (multiple-choice & true/false questions and recall data) in pretests and posttests respectively.

The scoring procedures for each measure are described as following:

TOEIC Bridge

The test was administered, scored, and reported by Sisa, Inc., an ETS vendor in Korea. The scores of LC and RC were reported respectively along with the total scores.

Recall Data

There were three English texts (photosynthesis, respiration, and cancer) and one Korean text (blood circulation and lymph) that were used for a recall task.

The original texts for three English texts and one Korean text were analyzed for the identification of propositions. One subject & predicate relationship was counted as one proposition. Since verbs always accompany a subject in English, every verb in the text was counted as one proposition, whether or not they belong to a main clause or dependent/embedded clauses. An infinitive such as “*to make their own food*” in the sentence, “*These organisms use the energy in sunlight to make their own food.*” was also counted as one proposition because it can be understood as “*these organisms make their own food,*” which indicates a subject & predicate relationship. A

prepositional phrase such as “*in sunlight*” also was counted as one proposition because it can also be understood as “*the energy is in sunlight,*” which indicates a subject & predicate relationship as well. The data of the proposition analyses with the original texts are provided in the appendix. The scores of recall in photosynthesis, respiration, and cancer were converted into the total score of 100 respectively because the total score for each topic slightly differs (80 for photosynthesis, 89 for respiration, and 85 for cancer).

Multiple-choice and True/False Tests

There were three English texts and one Korean text that were used for multiple-choice and true/false tests.

Three English texts have 18 questions (15 true/false and 3 multiple-choice): students’ responses to the questions in the test were scored dichotomously on the basis of their answers being right (1) or wrong (0). The total scores of the right answers were the sum of these values over questions. The Korean text has 20 questions (16 true/false and 4 multiple-choice): students’ responses to the questions in the test were scored dichotomously on the basis of their answers being right (1) or wrong (0). The total scores were the sum of these values over questions.

Scores of Vocabulary Knowledge

Two English texts used for the treatment conditions, ‘photosynthesis,’ and ‘respiration’ have the tests of vocabulary knowledge after the vocabulary knowledge acquisition activity. There were 42 English words that were provided in the activity

and tested in the 'photosynthesis' text and 44 English words for the 'respiration' text. Students' responses were dichotomously scored; correct translation of English words into Korean was given a 1, whereas incorrect translation or no response was given 0. The total score was the sum across all the items. The scores were converted into the total score of 40 respectively by proportionally rescaling them.

Scores of Schematic Knowledge

Two English texts used for the treatment conditions, 'photosynthesis,' and 'respiration' have the tests of schematic knowledge after the schematic knowledge acquisition activity. There were 52 blanks to be filled in the advanced organizer given in the activity and tested in the 'photosynthesis' text and 53 blanks in the 'respiration' text. Students' responses were dichotomously scored; correct provision of the word to be filled in the blank was given a 1, whereas incorrect provision of the word or leaving the blanks empty was given a 0. The total score was the sum across all the blanks. The scores were converted into a total score of 40 by proportionally rescaling them because the total score for each topic differs as in the case of recall data: for the vocabulary knowledge quiz, 42 is the total score for the topic of photosynthesis, and 44 is for the topic of respiration; for the schematic knowledge quiz, 52 is the total score for the topic of photosynthesis, and 53 is for the topic of respiration. The data of one participant was excluded because of its abnormal profile. The score of L2 proficiency ranked the second place out of 45 participants who took the TOEIC Bridge, whereas the score of L1 reading competence was the lowest among 33 students who took the test. In the context of English as a foreign language

(EFL), the correlation between L1 reading competence and L2 proficiency tends to be positive, which was confirmed with the data collected for the present study: the correlation between L1 (a composite score of L1MC and L1Rec) and L2 (a composite score of LC and RC of TOEIC Bridge) was .16; the correlation between L1MC and L2 was .383*; and the correlation between L1Rec and L2 was .08. The participant whose data was excluded had a profile of a highly negative direction in the relationship between L1 reading competence and L2 proficiency in relation to the data of the other students. Thus, it was determined that the comprehension processes for this particular student may not reflect in the rest of the students.

Since there are a considerable number of shortened terms, the summary of these terms are given in Table 4.1. These terms will be consistently used throughout the remainder of the dissertation.

4.2 Hypothesis 1

The first hypothesis is “*The comprehension of L2 reading texts will significantly improve when interventions of vocabulary knowledge acquisition or schematic knowledge acquisition are provided.*” To test this hypothesis, the analyses of the paired samples *t* tests were conducted. As shown in Figure 4.1 and Tables 4.4 – 4.9, there were no statistically significant differences found between CPreMC and

CPostMC and between CPreRec and CPostRec. However, the differences found between PreMC and PostMC and between PreRec and PostRec in the two treatment conditions were statistically significant. Based on the result, the first hypothesis is confirmed.

Table 4.1 Terms for different measures

Terms	Meaning
L2	the scores on TOEIC Bridge
LC	the scores on listening comprehension in TOEIC Bridge
RC	the scores on reading comprehension in TOEIC Bridge
L1	the composite scores on multiple-choice & T/F questions and recall in the Korean reading test
L1MC	the scores on multiple-choice & T/F questions in the Korean reading test
L1Rec	the scores on recall task in the Korean reading test
VocK	the scores on the quiz on vocabulary knowledge after the vocabulary knowledge acquisition activity
ScheK	the scores on the quiz on schematic knowledge after the schematic knowledge acquisition activity
VPreMC	the scores on the multiple-choice questions & T/F questions in the English text under the vocabulary knowledge acquisition condition before the vocabulary knowledge acquisition activity
VPostMC	the scores on the multiple-choice questions & T/F questions in the English text under the vocabulary knowledge acquisition condition after the vocabulary knowledge acquisition activity
VPreRec	the scores on the recall task in the English text under the vocabulary knowledge acquisition condition before the vocabulary knowledge acquisition activity
VPostRec	the scores on the recall task in the English text under the vocabulary knowledge acquisition condition after the vocabulary knowledge acquisition activity
SPreMC	the scores on the multiple choice questions and T/F questions in the English text under the schematic knowledge acquisition condition before the schematic knowledge acquisition activity
SPostMC	the scores on the multiple choice questions and T/F questions in the English text under the schematic knowledge acquisition condition after the schematic knowledge acquisition activity
SPreRec	the scores on the recall task in the English text under the schematic knowledge acquisition condition before the schematic knowledge acquisition activity
SPostRec	the scores on the recall task in the English text under the schematic knowledge acquisition condition after the schematic knowledge acquisition activity
CPreMC	the scores on the multiple-choice questions & T/F questions in the English text under the control pretest condition
CPostMC	the scores on the multiple-choice questions & T/F questions in the English text under the control posttest condition
CPreRec	the scores on the recall task in the English text under the control pretest condition
CPostRec	the scores on the recall task in the English text under the control posttest condition

Descriptive statistics for each variable is given below.

Table 4.2 Descriptive statistics – treatment groups

	N	Minimum	Maximum	Mean	Std. Deviation
L2	32	90.00	178.00	144.1250	19.77902
LC	32	52.00	90.00	72.6875	10.23100
RC	32	36.00	88.00	71.4375	11.17872
L1	32	25.00	67.50	46.8750	10.60660
L1Rec	32	11.50	52.50	32.8125	9.26644
Vock	32	19.00	40.00	35.5625	5.51208
VPreMC	32	6.00	18.00	11.3438	2.94694
VPostMC	32	5.00	18.00	12.5625	3.05791
VPreRec	32	1.00	51.00	21.7188	14.21320
VPostRec	32	10.00	57.00	28.4688	13.56224
ScheK	32	15.00	40.00	32.1875	7.77688
SPreMC	32	5.00	18.00	11.5312	3.32133
SPostMC	32	6.00	18.00	12.3125	3.45886
SPreRec	32	.00	38.00	21.4688	10.67099
SPostRec	32	7.00	51.00	29.2187	10.92713
Valid N (listwise)	32				

Table 4.3 Descriptive statistics for the control group

	N	Minimum	Maximum	Mean	Std. Deviation
L2	31	90.00	178.00	144.7742	20.24304
LC	31	52.00	90.00	73.3548	10.62559
RC	31	36.00	88.00	71.4194	11.29240
L1	31	25.50	67.50	47.8871	10.16014
L1MC	31	9.00	18.00	14.1613	2.46437
L1Rec	31	11.50	52.50	33.7258	9.05892
CPreMC	31	6.00	18.00	10.8710	2.95231
CPostMC	31	5.00	17.00	11.0000	3.33667
CPreRec	31	2.00	41.00	21.9516	11.47850
CPostRec	31	2.50	42.00	23.3871	12.23908
Valid N (listwise)	31				

Figure 4.1 Change of comprehension between pretests and posttests in three conditions

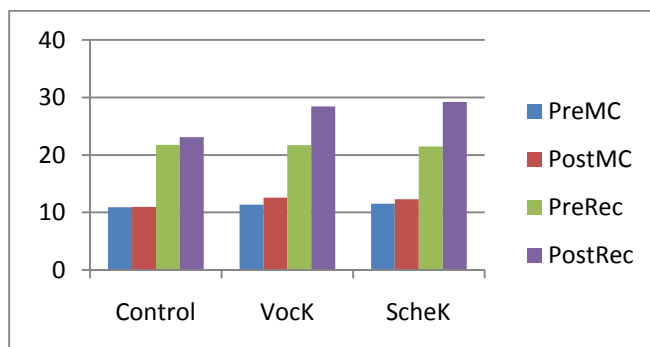

Table 4.4 Paired Samples Correlations

		N	Correlation	Sig.
Pair 1	CPostMC & CPreMC	31	.856	.000
Pair 2	CPostRec & CPreRec	31	.901	.000

Table 4.5 Paired Samples Correlations

		N	Correlation	Sig.
Pair 1	VPostMC & VPreMC	32	.751	.000
Pair 2	VPostRec & VPreRec	32	.797	.000

Table 4.6 Paired Samples Correlations

		N	Correlation	Sig.
Pair 1	SPostMC & SPreMC	32	.836	.000
Pair 2	SPostRec & SPreRec	32	.812	.000

Table 4.7 Paired Samples Test

		Paired Differences				t	df	Sig. (2-tailed)	
					95% Confidence Interval of the Difference				
		Mean	Std. Deviation	Std. Error Mean	Lower				Upper
Pair 1	CPostMC - CPreMC	.12903	1.72708	.31019	-.50446	.76253	.416	30	.680n.s.
Pair 2	CPostRec - CPreRec	1.43548	5.31937	.95539	-.51568	3.38664	1.503	30	.143n.s.

Table 4.8 Paired Samples Test

		Paired Differences				t	df	Sig. (2-tailed)	
					95% Confidence Interval of the Difference				
		Mean	Std. Deviation	Std. Error Mean	Lower				Upper
Pair 1	VPostMC - VPreMC	1.21875	2.12108	.37496	.45402	1.98348	3.250	31	.003*
Pair 2	VPostRec - VPreRec	6.75000	8.87185	1.56834	3.55136	9.94864	4.304	31	.000*

Table 4.9 Paired Samples Test

		Paired Differences				t	df	Sig. (2-tailed)	
					95% Confidence Interval of the Difference				
		Mean	Std. Deviation	Std. Error Mean	Lower				Upper
Pair 1	SPostMC - SPreMC	.78125	1.94662	.34412	.07942	1.48308	2.270	31	.030*
Pair 2	SPostRec - SPreRec	7.75000	6.61864	1.17002	5.36372	10.13628	6.624	31	.000*

4.3 Hypothesis 2

The second hypothesis explored is “*The effect of L1 reading competence and L2 language proficiency will be different in the two treatment conditions: 2.1: L1 reading competence will be a stronger predictor for the condition of a schematic knowledge activity; 2.2: L2 language proficiency will be a stronger predictor for the condition of a vocabulary knowledge activity.* This concerns the effect of L1 reading competence and L2 proficiency upon the different treatment types. L1 reading competence was hypothesized to be a stronger predictor for the activity of schematic knowledge acquisition, whereas L2 proficiency was hypothesized to be a stronger predictor for the activity of vocabulary knowledge acquisition.

To investigate this hypothesis, five variables were entered into a LISREL model; two L1 measures (L1MC and L1Rec) as indicators for latent L1 reading competence and two L2 measures (LC and RC) as indicators for latent L2 proficiency along with the scores of the vocabulary knowledge acquisition activity and the schematic knowledge acquisition activity respectively. As shown in the path diagrams in Figures 4.2 and 4.3, the second hypothesis is confirmed. The standardized loading of the path from L2 to LVocK is .54* (Z score is 2.76, which is significant at the α level of .05), whereas the standardized loading of the path from L1 to LVocK is .06 (Z score is .34, which is not significant at the α level of .05). The pattern is reversed in the schematic knowledge condition. The loading of the path from L1 to LScheK is .70* (Z score is 2.29, which is significant at the α level of .05), whereas the loading of the path from L2 to LScheK is .13 (Z score is .69, which is not significant at the α level of .05). Thus, the second hypothesis is confirmed.

Figure 4.2 Relative contributions of L1 and L2 to the vocabulary knowledge

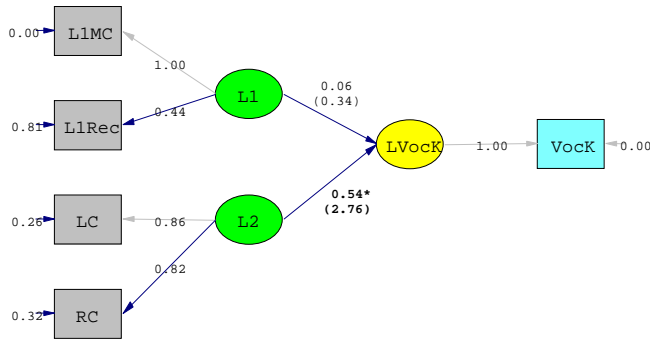
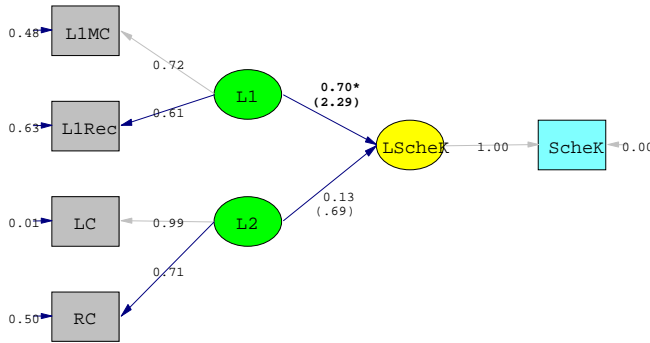

Figure 4.3 Relative contributions of L1 and L2 to the schematic knowledge



Keys for the terms in Figures 4.2 and 4.3

- L1MC: the scores on L1 (Korean) reading comprehension test measured by multiple-choice & T/F questions
- L1Rec: the scores on L1 (Korean) reading comprehension tests measured by recall task
- L1: L1 reading comprehension
- LC: the scores on listening comprehension test in TOEIC Bridge
- RC: the scores on reading comprehension test in TOEIC Bridge
- L2: latent variable for English proficiency
- LVoc: latent variable for vocabulary knowledge
- VocK: the scores on the quiz on the vocabulary knowledge acquisition activity
- LScheK: latent variable for schematic knowledge
- ScheK: the scores on the quiz on the schematic knowledge acquisition activity

4.4 Hypothesis 3

The third hypothesis, “*The effect of different L1 reading competence upon L2 reading comprehension in the pretests for all conditions (one control condition and two treatment conditions) will be minimal due to the linguistic threshold or bottle*”

neck effect” explores what has been examined in the previous research, the linguistic threshold hypothesis. To examine the role of L1 reading competence in a finer-grained level, each of the two L1 measures (L1MC and L1Rec) was analyzed separately, which produced several path diagrams at four levels; (1) L1MC with L2CompMC in three conditions (VPre, SPre, and CPre), (2) L1MC with L2CompRec in three conditions, (3) L1Rec with L2CompMC in three conditions, and (4) L1Rec with L2CompRec in three conditions. As shown in Figure 4.4 and Figure 4.5, L1MC is not a significant predictor for either L2CompMC or L2CompRec in the three pretest conditions; -0.11 (-0.64) in VPreMC, -0.08 (-0.48) in SPreMC, .21 (1.29) in CPreMC, 0.21 (1.34) in VPreRec, 0.14 (1.00) in SPreRec, and 0.04 (0.24) in CPreRec (standardized loading and Z score in each parenthesis, 1.96 is a critical Z value at $\alpha=.05$).

L1Rec is not a significant predictor for L2CompMC in the three pretest conditions either as show in Figure 4.6; 0.11 (0.76) in VPreMC, -0.07 (-0.47) in SPreMC, and 0.24 (1.73) in CPreMC. However, L1Rec is a significant predictor for L2CompRec in the three conditions as shown in Figure 4.7; 0.41* (3.13) in VPreRec, 0.38* (3.23) in SPreRec, and 0.54* (4.17) in CPreRec. Based on this result, it is interpreted that the bottleneck effect of limited L2 proficiency, which brings about impoverished textbase, did not allow readers to tap into their L1 reading competence,

Figure 4.4 **L1MC** (Korean reading comprehension measured by multiple-choice and T/F questions) **with L2CompMC** (English reading comprehension measured by multiple-choice and T/F questions) **in the pretest conditions**

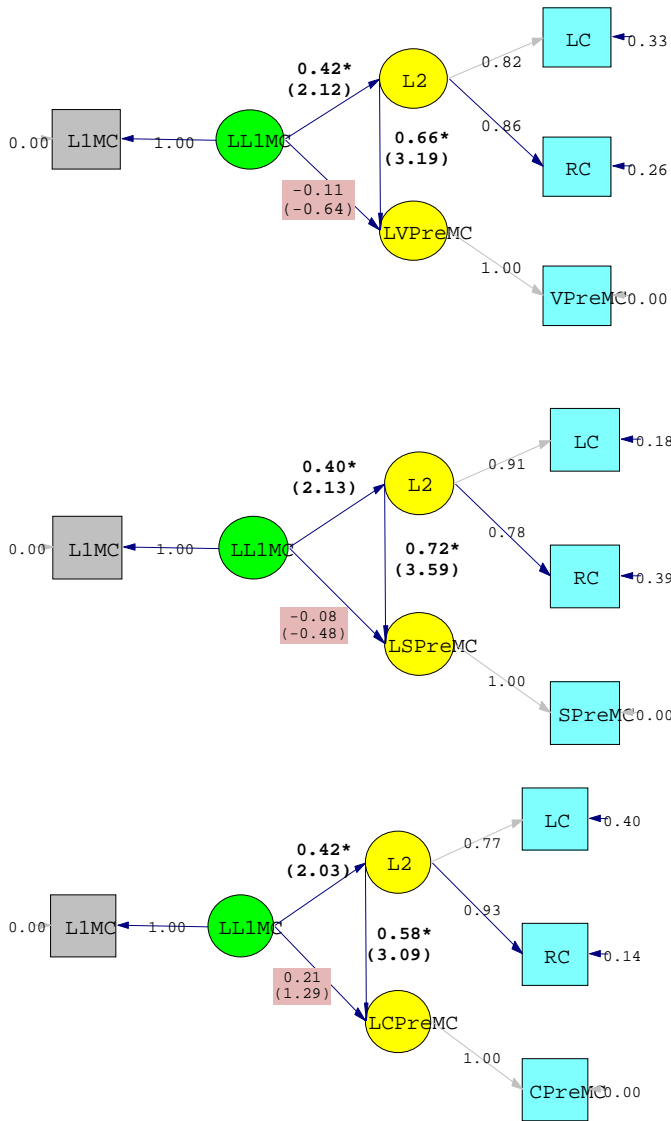

Keys for the terms in Figure 4.4

- L1MC: the scores on L1 (Korean) reading comprehension test measured by multiple-choice & T/F questions
- LL1MC: latent variable for L1MC
- LC: the scores on listening comprehension test in TOEIC Bridge
- RC: the scores on reading comprehension test in TOEIC Bridge
- L2: latent variable for English proficiency
- VPreMC: the scores on English reading comprehension measured by multiple-choice and T/F questions in the pretest of the vocabulary acquisition condition
- L2CompMC: latent variable for VPreMC
- SPreMC: the scores on English reading comprehension measured by multiple-choice and T/F questions in the pretest of the schematic knowledge acquisition condition
- L2PreMC: latent variable for SPreMC
- CPreMC: the scores on English reading comprehension measured by multiple-choice and T/F questions in the pretest of the control condition
- L2PreMC: latent variable for CPreMC

Figure 4.5 **L1MC** (Korean reading comprehension measured by multiple-choice and T/F questions) **with L2CompRec** (English reading comprehension measured by a recall task) **in the pretest conditions**

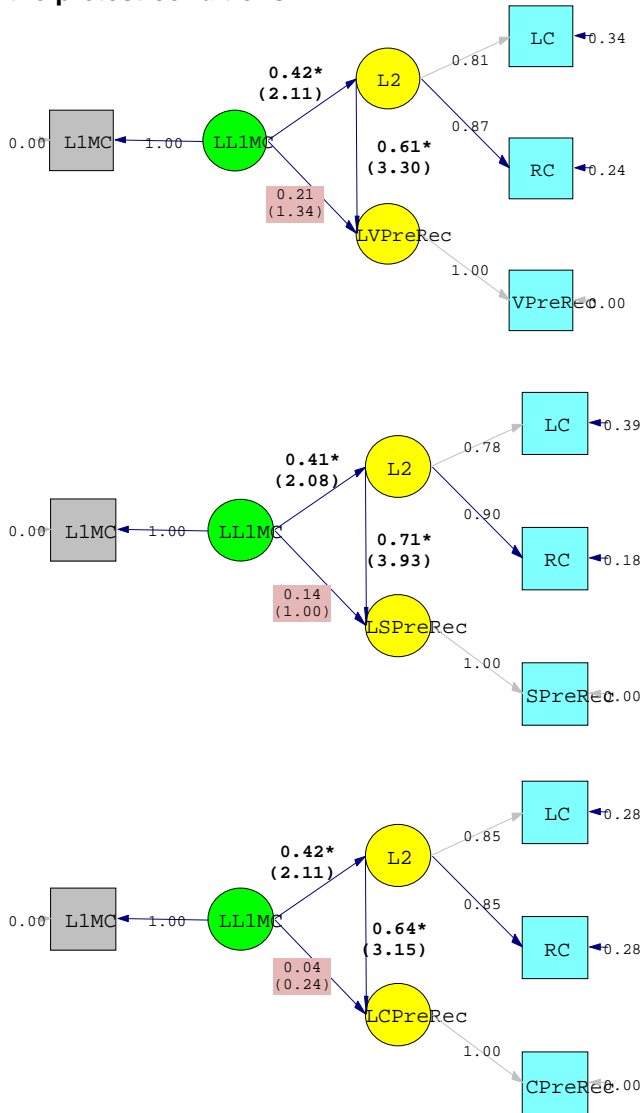

Keys for the terms in Figure 4.5

- L1MC: the scores on L1 (Korean) reading comprehension test measured by multiple-choice & T/F questions
- LL1MC: latent variable for L1MC
- LC: the scores on listening comprehension test in TOEIC Bridge
- RC: the scores on reading comprehension test in TOEIC Bridge
- L2: latent variable for English proficiency
- VPreRec: the scores on English reading comprehension measured by a recall task in the pretest of the vocabulary acquisition condition
- L2CompRec: latent variable for VPreRec
- SPreRec: the scores on English reading comprehension measured by a recall task in the pretest of the schematic knowledge acquisition condition
- L2CompRec: latent variable for SPreRec
- CPreRec: the scores on English reading comprehension measured by a recall task in the pretest of the control condition
- L2CompRec: latent variable for CPreRec

Figure 4.6 L1Rec (Korean reading comprehension measured by a recall task) with L2CompMC (English reading comprehension measured by multiple-choice and T/F questions) in the pretest conditions

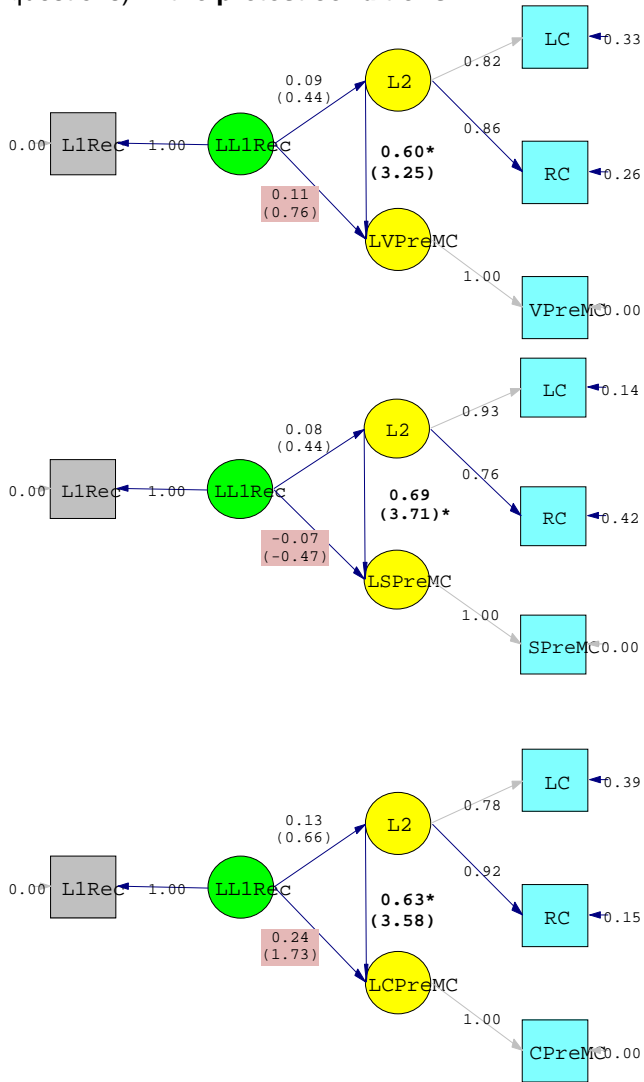

Keys for the terms in Figure 4.6

- L1Rec: the scores on L1 (Korean) reading comprehension test measured by a recall task
- LL1Rec: latent variable for L1Rec
- LC: the scores on listening comprehension test in TOEIC Bridge
- RC: the scores on reading comprehension test in TOEIC Bridge
- L2: latent variable for English proficiency
- VPreMC: the scores on English reading comprehension measured by multiple-choice and T/F questions in the pretest of the vocabulary acquisition condition
- LVPreMC: latent variable for VPreMC
- SPreMC: the scores on English reading comprehension measured by multiple-choice and T/F questions in the pretest of the schematic knowledge acquisition condition
- LSPreMC: latent variable for SPreMC
- CPreMC: the scores on English reading comprehension measured by multiple-choice and T/F questions in the pretest of the control condition
- LCPreMC: latent variable for CPreMC

Figure 4.7 L1Rec (Korean reading comprehension measured by a recall task) with L2CompRec (English reading comprehension measured by a recall task) in the pretest conditions

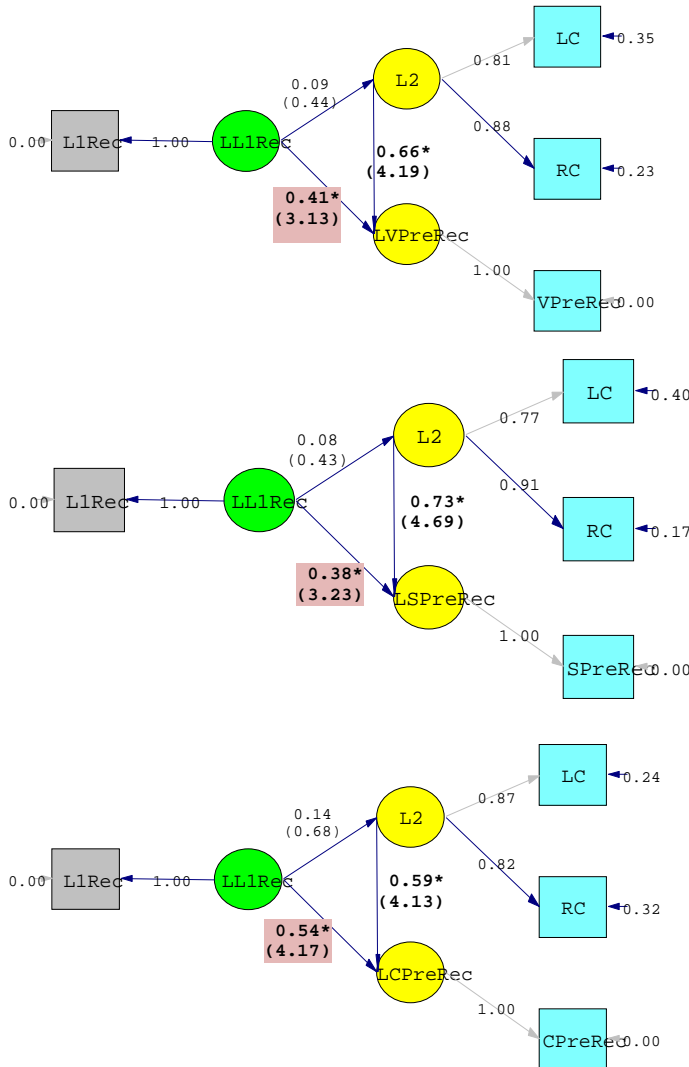

Keys for the terms in Figure 4.7

- L1Rec: the scores on L1 (Korean) reading comprehension test measured by a recall task
- LL1Rec: latent variable for L1Rec
- LC: the scores on listening comprehension test in TOEIC Bridge
- RC: the scores on reading comprehension test in TOEIC Bridge
- L2: latent variable for English proficiency
- VPreRec: the scores on English reading comprehension measured by a recall task in the pretest of the vocabulary acquisition condition
- L2CompRec: latent variable for VPreRec
- SPreRec: the scores on English reading comprehension measured by a recall task in the pretest of the schematic knowledge acquisition condition
- L2PreRec: latent variable for SPreRec
- CPreRec: the scores on English reading comprehension measured by a recall task in the pretest of the control condition
- L2CompPreRec: latent variable for CPreRec

leaving L2 proficiency as the only significant predictor, except the condition of L1Rec with L2CompRec; the loadings of the paths from L1 to L2Comp in all path diagrams are shaded. One interesting pattern found in the relationships among L1MC, L2, and L2Comp is that even though L1MC does not have a statistically significant direct contribution to the L2CompMC and L2CompRec, L1MC does have a statistically significant indirect contribution to the L2CompMC and L2CompRec via L2. The loadings from L1MC to L2 are $.42*(2.12)$ in VPreMC, $0.40*(2.13)$ in SPreMC, $0.42*(2.03)$ in CPreMC, $0.42*(2.11)$ in VPreRec, $0.41*(2.08)$ in SPreRec, and $0.42*(2.11)$ in CPreRec.

4.5 Hypothesis 4

To examine the fourth hypothesis, “*There will be different effects of an intervention type upon comprehension, which will be shown in different reading comprehension measures and item types, such as multiple-choice and true/false questions and recall, as well as their related cognitive processes.*,” the measures of L1 reading competence, L2 vocabulary/schematic knowledge, and L2 reading comprehension of the posttests were entered into LISREL. Based on the result of the hypothesis two, only the paths with significant loadings from L1 and L2 to vocabulary and schematic knowledge were included in this analysis. That is, the path from L1 to VocK and the path from L2 to ScheK are not included in the structural model because the loadings in each path are not significant. The indices for goodness of fit indicate good model fit except three models, the L1MC with L2CompRec in

ScheK acquisition condition, the L1Rec with L2CompMC in ScheK acquisition condition, and the L1Rec with L2CompRec in ScheK acquisition condition.

There are interesting distinct patterns observed in the analysis of the posttests in two treatment conditions. There is a good contrast in the change of the proportion of the variance that L2 explains for the measures of L2Comp after the different type of treatment. The loadings of the path from L2 to L2Comp or the variance that L2 explains drastically decreased after the vocabulary knowledge acquisition activity regardless of the type of measures (VPostMC or VPostRec) as shown in Figure 4.8.1, Figure 4.8.2, Figure 4.8.3, and Figure 4.8.4; (1) from .66* to .48* in L1MC with L2CompMC, (2) from .61* to .16 in L1MC with L2CompRec, (3) from .60* to .46* in L1Rec with L2CompMC, and (4) from .66* to .24 in L1Rec with L2CompRec.

However, after the schematic knowledge acquisition activity, the proportion of the variance that L2 explains noticeably increased in L2CompMC as shown in the Figure 4.9.1 and the Figure 4.9.3 (from .72* to .83* in L1MC with L2CompMC; and from .69* to .80* in L1Rec with L2CompMC) but decreased in L2CompRec as shown in the Figure 4.9.2 and the Figure 4.9.4 (from .71* to .40* in L1MC with L2CompRec; and from .73* to .48* in L1Rec with L2CompRec). This indicates that the acquisition of vocabulary knowledge decreased the dependence on L2 consistently at all four levels, whereas the acquisition of schematic knowledge increased dependence on L2 in L2CompMC but decreased dependence on L2 in L2CompRec.

Figure 4.8.1 **L1MC** (Korean reading comprehension measured by multiple-choice and T/F questions) **with L2CompMC** (English reading comprehension measured by multiple-choice and T/F questions) **in the vocabulary knowledge acquisition condition**

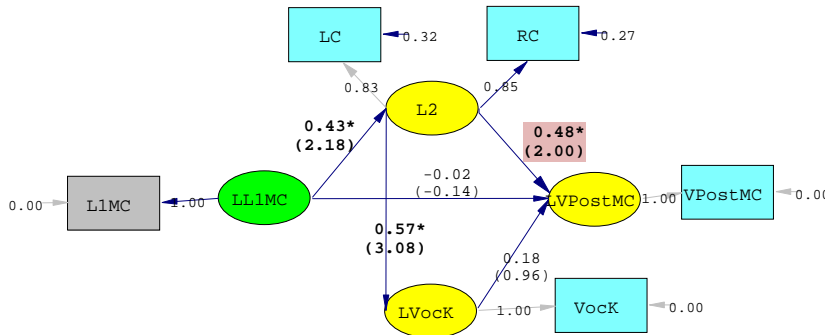

Keys for the terms in Figure 4.8.1

- L1MC: the scores on L1 (Korean) reading comprehension test measured by multiple-choice & T/F questions
- LL1MC: latent variable for L1MC
- LC: the scores on listening comprehension test in TOEIC Bridge
- RC: the scores on reading comprehension test in TOEIC Bridge
- L2: latent variable for English proficiency
- VPostMC: the scores on English reading comprehension measured by multiple-choice and T/F questions in the posttest of the vocabulary acquisition condition
- LVPoStMC: latent variable for VPostMC
- VocK: the scores on quiz on the vocabulary knowledge acquisition activity
- LVocK: latent variable for VocK

Figure 4.8.2 **L1MC** (Korean reading comprehension measured by multiple-choice and T/F questions) **with L2CompRec** (English reading comprehension measured by a recall task) **in the vocabulary knowledge acquisition condition**

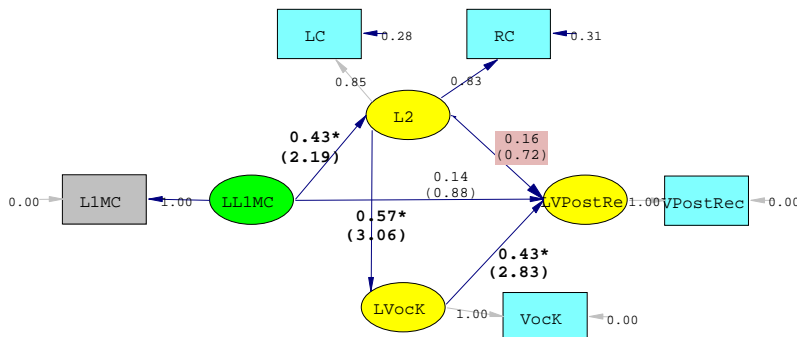

Keys for the terms in Figure 4.8.2

- L1MC: the scores on L1 (Korean) reading comprehension test measured by multiple-choice & T/F questions
- LL1MC: latent variable for L1MC
- LC: the scores on listening comprehension test in TOEIC Bridge
- RC: the scores on reading comprehension test in TOEIC Bridge
- L2: latent variable for English proficiency
- VPostRec: the scores on English reading comprehension measured by a recall task in the posttest of the vocabulary acquisition condition
- LVPoStRe: latent variable for VPostRec
- VocK: the scores on quiz on the vocabulary knowledge acquisition activity
- LVocK: latent variable for VocK

Figure 4.8.3 **L1Rec** (Korean reading comprehension measured by a recall task) **with L2CompMC** (English reading comprehension measured by multiple-choice and T/F questions) **in the vocabulary knowledge acquisition condition**

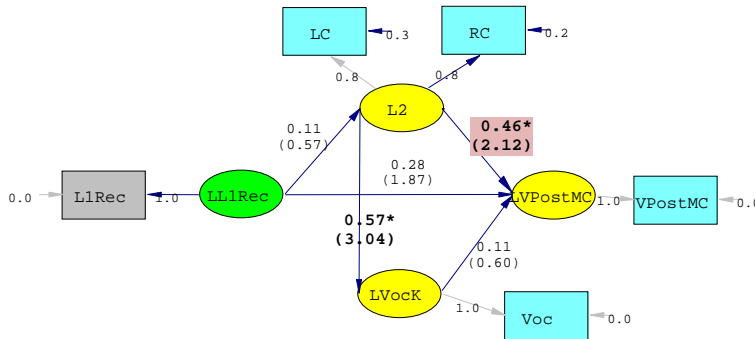

Keys for the terms in Figure 4.8.3

- L1Rec: the scores on L1 (Korean) reading comprehension test measured by a recall task
- LL1Rec: latent variable for L1Rec
- LC: the scores on listening comprehension test in TOEIC Bridge
- RC: the scores on reading comprehension test in TOEIC Bridge
- L2: latent variable for English proficiency
- VPostMC: the scores on English reading comprehension measured by multiple-choice and T/F questions in the posttest of the vocabulary acquisition condition
- L2VocK: latent variable for VPostMC
- VocK: the scores on quiz on the vocabulary knowledge acquisition activity
- LVocK: latent variable for VocK

Figure 4.8.4 **L1Rec** (Korean reading comprehension measured by a recall task) **with L2CompRec** (English reading comprehension measured by a recall task) **in the vocabulary knowledge acquisition condition**

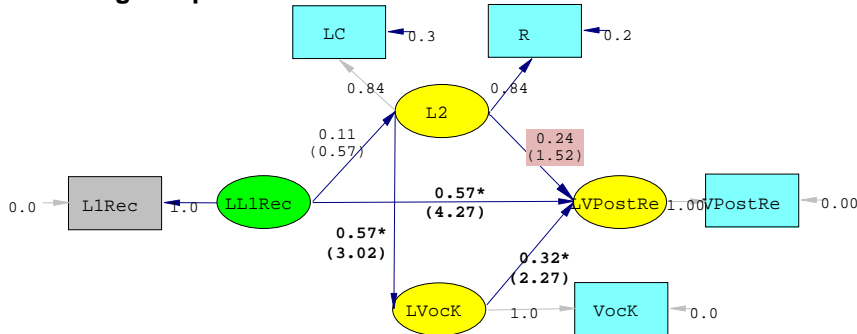

Keys for the terms in Figure 4.8.4

- L1Rec: the scores on L1 (Korean) reading comprehension test measured by a recall task
- LL1Rec: latent variable for L1Rec
- LC: the scores on listening comprehension test in TOEIC Bridge
- RC: the scores on reading comprehension test in TOEIC Bridge
- L2: latent variable for English proficiency
- VPostRec: the scores on English reading comprehension measured by a recall task in the posttest of the vocabulary acquisition condition
- L2VocK: latent variable for VPostRec
- VocK: the scores on quiz on the vocabulary knowledge acquisition activity
- LVocK: latent variable for VocK

Figure 4.9.1 L1MC (Korean reading comprehension measured by multiple-choice and T/F questions) with L2CompMC (English reading comprehension measured by multiple-choice and T/F questions) in the schematic knowledge acquisition condition

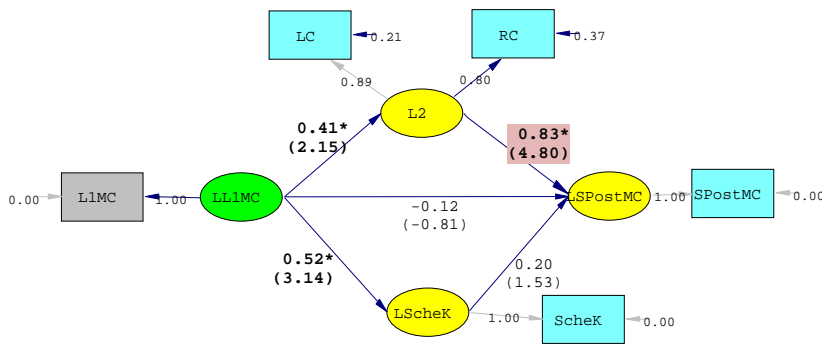

Keys for the terms in Figure 4.9.1

- L1MC: the scores on L1 (Korean) reading comprehension test measured by multiple-choice & T/F questions
- LL1MC: latent variable for L1MC
- LC: the scores on listening comprehension test in TOEIC Bridge
- RC: the scores on reading comprehension test in TOEIC Bridge
- L2: latent variable for English proficiency
- SPostMC: the scores on English reading comprehension measured by multiple-choice and T/F questions in the posttest of the schematic knowledge acquisition condition
- L2CompMC: latent variable for VPostMC
- ScheK: the scores on quiz on the schematic knowledge acquisition activity
- L2CompScheK: latent variable for ScheK

Figure 4.9.2 L1MC (Korean reading comprehension measured by multiple-choice and T/F questions) with L2CompRec (English reading comprehension measured by a recall task) in the schematic knowledge acquisition condition

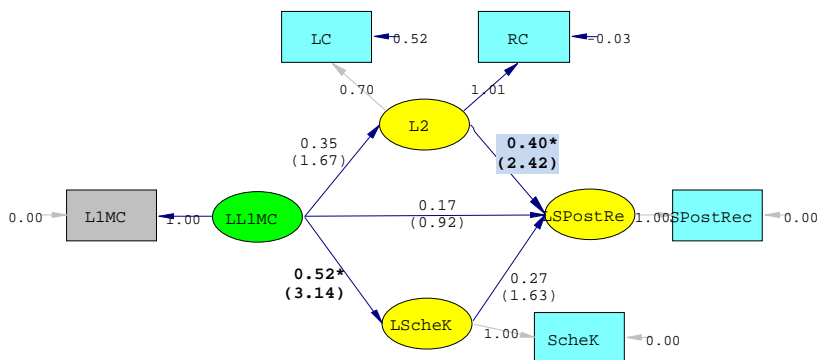

Keys for the terms in Figure 4.9.2

- L1MC: the scores on L1 (Korean) reading comprehension test measured by multiple-choice & T/F questions
- LL1MC: latent variable for L1MC
- LC: the scores on listening comprehension test in TOEIC Bridge
- RC: the scores on reading comprehension test in TOEIC Bridge
- L2: latent variable for English proficiency
- SPostRec: the scores on English reading comprehension measured by a recall task in the posttest of the schematic knowledge acquisition condition
- L2CompRec: latent variable for VPostRec
- ScheK: the scores on quiz on the schematic knowledge acquisition activity
- L2CompScheK: latent variable for ScheK

Figure 4.9.3 L1Rec (Korean reading comprehension measured by a recall task) with L2CompMC (English reading comprehension measured by multiple-choice and T/F questions) in the schematic knowledge acquisition condition

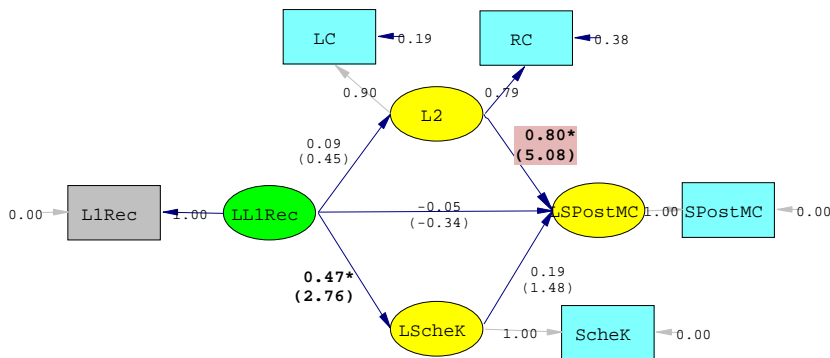

Keys for the terms in Figure 4.9.3

- L1Rec: the scores on L1 (Korean) reading comprehension test measured by a recall task
- LL1Rec: latent variable for L1Rec
- LC: the scores on listening comprehension test in TOEIC Bridge
- RC: the scores on reading comprehension test in TOEIC Bridge
- L2: latent variable for English proficiency
- SPostMC: the scores on English reading comprehension measured by multiple-choice and T/F questions in the posttest of the schematic knowledge acquisition condition
- LSPostMC: latent variable for VPostMC
- ScheK: the scores on quiz on the schematic knowledge acquisition activity
- LScheK: latent variable for ScheK

Figure 4.9.4 L1Rec (Korean reading comprehension measured by a recall task) with L2CompRec (English reading comprehension measured by a recall task) in the schematic knowledge acquisition condition

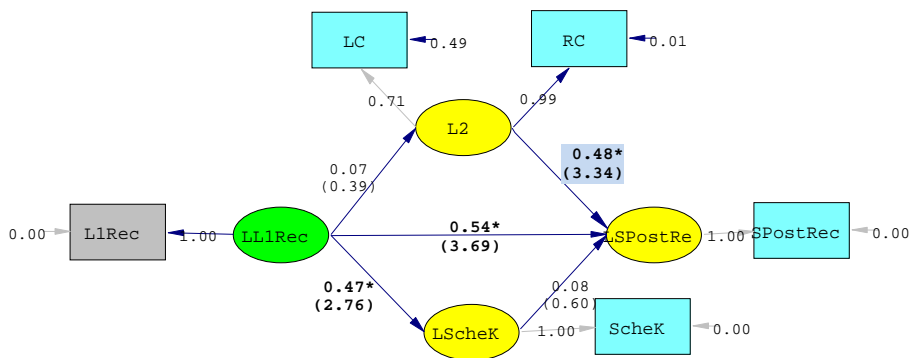

Keys for the terms in Figure 4.9.4

- L1Rec: the scores on L1 (Korean) reading comprehension test measured by a recall task
- LL1Rec: latent variable for L1Rec
- LC: the scores on listening comprehension test in TOEIC Bridge
- RC: the scores on reading comprehension test in TOEIC Bridge
- L2: latent variable for English proficiency
- SPostRec: the scores on English reading comprehension measured by a recall task in the posttest of the schematic knowledge acquisition condition
- LSPostRec: latent variable for VPostRec
- ScheK: the scores on quiz on the schematic knowledge acquisition activity
- LScheK: latent variable for ScheK

The summary of the change in the loadings for two treatment conditions is provided in Tables 4.10 – 4.12; the role of L2 proficiency in Table 4.10; the role of different L1 measures (L1MC and L1Rec) in Table 4.11; and the role of L1 reading competence to L2 proficiency in Table 4.12.

4.6 Hypothesis 5

The last hypothesis examines the validity of the proposed theory. “*The textbase, whose indicators include L2 proficiency (LC and RC) and vocabulary knowledge, and the situation model, whose indicators include L1 reading competence (L1MC and L1Rec) and schematic knowledge, will successfully explain L2 reading comprehension.*” To test this hypothesis, the measurement model of two latent variables (textbase and situation model) was run in LISREL; measurement model refers to the model without any structural paths added, and the purpose of checking the good of fit for measurement model is to ensure that the indicators assigned to each latent variable indeed explain each latent variable. With one suggested modification by LISREL (correlated error covariance between VocK and ScheK makes sense in that the variances that are not explained in two treatment conditions, VocK and ScheK, are still likely to correlate each other based on the rationale of general logics) as shown in Figure 4.10, the fit of the model (textbase with the scores of LC, RC, and VocK and situation model with the scores of L1MC, L1Rec, and ScheK) reached acceptable values for goodness of fit indices; $\chi^2 = 4.85$ (df = 7, $p = 0.68$); SRMR = 0,066; RMSEA = 0.0 CI₉₀: (0.0, 0.17); CFI = 1 (target values to retain a model are SRMR < 0.08, RMSEA < 0.06, CFI ≥ 0.95).

Table 4.10 Relative contributions of L2 proficiency to different L2 reading comprehension measures in different treatment conditions

Vocabulary Knowledge Condition			
◇Exogenous Variables	Pre	Post	◇Endogenous Variables
L2 in L1MC	.66* (3.19)	.48* (2.00)	L2CompMC
	.61* (3.30)	.16 (0.72)	L2CompRec
L2 in L1Rec	.60* (3.25)	.46* (2.12)	L2CompMC
	.66* (4.19)	.24 (1.52)	L2CompRec

Schematic Knowledge Condition			
Exogenous Variables	Pre	Post	Endogenous Variables
L2 in L1MC	.72* (3.59)	.83* (4.80)	L2CompMC
	.71* (3.93)	.40* (2.42)	L2CompRec
L2 in L1Rec	.69* (3.71)	.80* (5.08)	L2CompMC
	.73* (4.69)	.48* (3.34)	L2CompRec

◇ Exogenous variables refer to the predictors, and endogenous variables refer to the outcome variables in SEM

Table 4.11 Relative contributions of L1 reading competence to different L2 reading comprehension measures in different treatment conditions

Vocabulary Knowledge Condition			
◇Exogenous Variables	Pre	Post	◇Endogenous Variables
L1MC	-.11 (-0.64)	-.02 (-0.14)	L2CompMC
	.21 (1.34)	.14 (0.88)	L2CompRec
L1Rec	.11 (0.76)	.28 (1.87)	L2CompMC
	.41* (3.13)	.57* (4.27)	L2CompRec

Schematic Knowledge Condition			
Exogenous Variables	Pre	Post	Endogenous Variables
L1MC	-.08 (-0.48)	-.12 (-0.81)	L2CompMC
	.14 (1.00)	.17 (0.92)	L2CompRec
L1Rec	-.07 (-0.47)	-.05 (-0.34)	L2CompMC
	.38* (3.23)	.54* (3.69)	L2CompRec

◇ Exogenous variables refer to the predictors, and endogenous variables refer to the outcome variables in SEM

Table 4.12 Relative contributions of L1 reading competence to L2 proficiency in different treatment conditions

Vocabulary Knowledge Condition			
◇Exogenous Variables	Pre	Post	◇Endogenous Variables
L1MC	.42* (2.12)	.43* (2.18)	L2 in L2CompMC
	.42* (2.11)	.43* (2.19)	L2 in L2CompRec
L1Rec	.09 (0.44)	.11 (0.57)	L2 in L2CompMC
	.09 (0.44)	.11 (0.57)	L2 in L2CompRec

Schematic Knowledge Condition			
Exogenous Variables	Pre	Post	Endogenous Variables
L1MC	.40* (2.13)	.41* (2.15)	L2 in L2CompMC
	.41* (2.08)	.35 (1.67)	L2 in L2CompRec
L1Rec	.08 (0.44)	.09 (0.45)	L2 in L2CompMC
	.08 (0.43)	.07 (0.39)	L2 in L2CompRec

◇ Exogenous variables refer to the predictors, and endogenous variables refer to the outcome variables in SEM

In order to examine whether or not the proposed CI model for L2 reading comprehension explains L2 reading comprehension with an acceptable model fit, several models were run through LISREL. The indicators for L2Comp from the pretests were analyzed first. The indicators for L2Comp have three different combinations; the first consists of VPreMC and SPreMC, the second consists of VPreRec and SPreRec, and the third is the mixture of both, which is VPreMC, SPreMC, VPreRec, and SPreRec. The information on the goodness of fit is given in the Table 4.13. The sign of * indicates a good model fit. In order to examine if the data from the post-tests also support the proposed theory, the same sets of variables in the same combinations were run via LISREL. The values on the fit indices are given

Figure 4.10 Measurement Model of Construction Integration Model for L2 reading comprehension

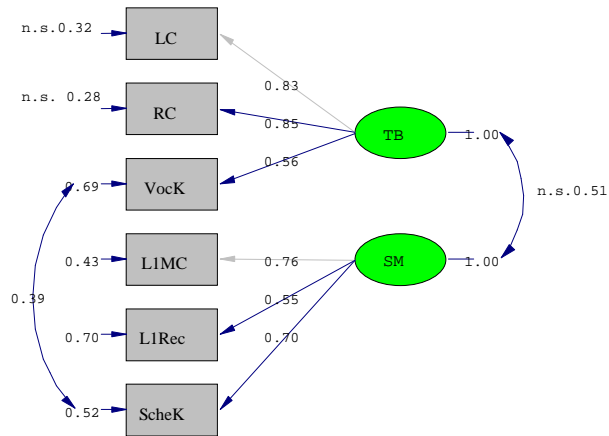

Keys for the terms in Figure 4.10

- LC: the scores on listening comprehension in TOEIC Bridge
- RC: the scores on reading comprehension in TOEIC Bridge
- VocK: the scores on quiz on the vocabulary knowledge acquisition activity
- TB: latent variable for textbase
- L1MC: the scores on Korean reading comprehension measured by multiple-choice and T/F questions
- L1Rec: the scores on Korean reading comprehension measured by a recall task
- ScheK: the scores on quiz on the schematic knowledge acquisition activity
- SM: latent variable for situation model

in the Table 7 as well. The path diagram for each model is provided in the Figure 4.11 ~ Figure 4.15; the LISREL program failed to produce a path diagram for the model of PostL2Comp(MC&Rec), even though it yielded values for model fit.

Figure 4.16 was created by hand, using the values available in the output (estimates and z scores): note that since no standardized loadings for paths are available in the output, estimated values for these pathes are inserted in Figure 4.16 .

Table 4.13 Goodness of fit of the CI model with different L2 comprehension measures

Criteria of good model fit	PreL2CompMC Figure 6.2	PreL2CompRec Figure 6.3	PreL2Comp(MC&Rec) Figure 6.4
χ^2 (df, p)	10.28 (df=16, $p = 0.85$)	21.28 (df=16, $p = 0.17$)	41.46 (df=31, $p = 0.099$)
SRMR < 0.08	0.071*	0.069*	0.082
RMSEA < 0.06 CI ₉₀ (;)	0.0* CI ₉₀ (0.0; 0.081)	0.11 CI ₉₀ (0.0; 0.21)	0.098 CI ₉₀ (0.0; 0.18)
CFI \geq 0.95	1*	0.97*	0.96*
Criteria of good model fit	PostL2CompMC Figure 6.5	PostL2CompRec Figure 6.6	PostL2Comp(MC&Rec) No Figure available
χ^2 (df, p)	12.75 (df =16, $p = 0.69$)	25.64 (df=16, $p = 0.059$)	54.28 (df=31, $p = 0.006$)
SRMR < 0.08	0.07*	0.17	0.16
RMSEA < 0.06 CI ₉₀ (;)	0.0* CI ₉₀ (0.0; 0.13)	0.14 CI ₉₀ (0.010; 0.24)	0.16 CI ₉₀ (0.093; 0.23)
CFI \geq 0.95	1*	0.94	0.91

Figure 4.11 The Construction Integration Model for L2 Reading – PreL2CompMC (English reading comprehension measured by multiple-choice and T/F questions in the pretests)

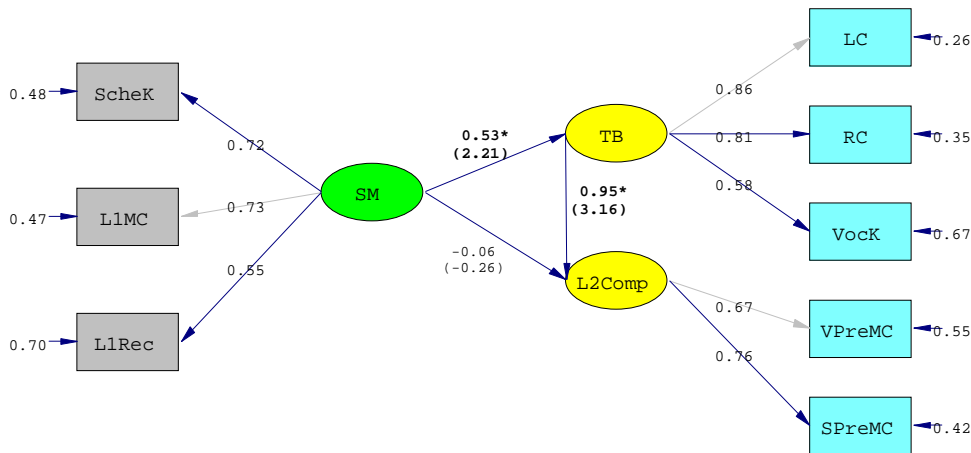

Keys for the terms in Figure 4.11

- ScheK: the scores on quiz on the schematic knowledge acquisition activity
- L1MC: the scores on Korean reading comprehension measured by multiple-choice and T/F questions
- L1Rec: the scores on Korean reading comprehension measured by a recall task
- SM: latent variable for situation model
- LC: the scores on listening comprehension in TOEIC Bridge
- RC: the scores on reading comprehension in TOEIC Bridge
- VocK: the scores on quiz on the vocabulary knowledge acquisition activity
- TB: latent variable for textbase
- L2Comp: latent variable for English reading comprehension
- VPreMC: the scores on English reading comprehension measured by multiple-choice and T/F questions in the pretest of the vocabulary knowledge acquisition condition
- SPreMC: the scores on English reading comprehension measured by multiple-choice and T/F questions in the pretest of the schematic knowledge acquisition condition

Figure 4.12 **The Construction Integration Model for L2 Reading – PreL2CompRec** (English reading comprehension measured by a recall task in the pretests)

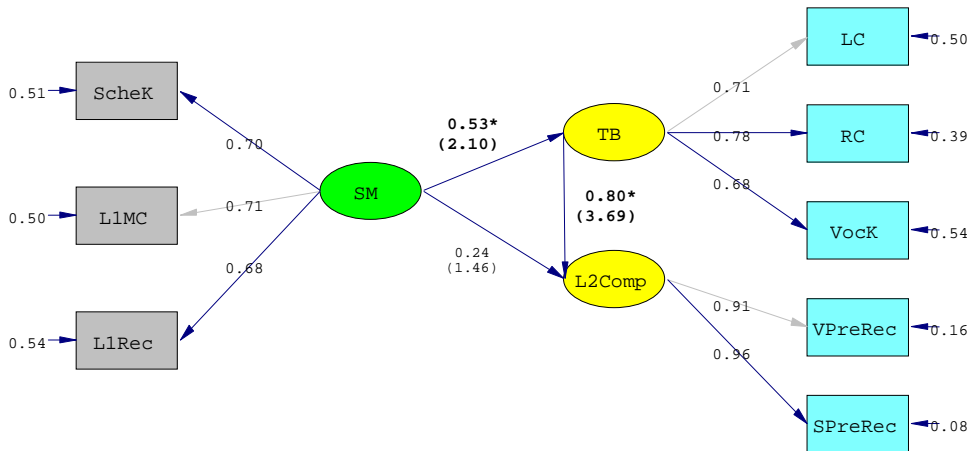

Keys for the terms in Figure 4.12

- ScheK: the scores on quiz on the schematic knowledge acquisition activity
- L1MC: the scores on Korean reading comprehension measured by multiple-choice and T/F questions
- L1Rec: the scores on Korean reading comprehension measured by a recall task
- SM: latent variable for situation model
- LC: the scores on listening comprehension in TOEIC Bridge
- RC: the scores on reading comprehension in TOEIC Bridge
- VocK: the scores on quiz on the vocabulary knowledge acquisition activity
- TB: latent variable for textbase
- L2Comp: latent variable for English reading comprehension
- VPreRec: the scores on English reading comprehension measured by a recall task in the pretest of the vocabulary knowledge acquisition condition
- SPreRec: the scores on English reading comprehension measured by a recall task in the pretest of the schematic knowledge acquisition condition

Figure 4.13 **The Construction Integration Model for L2 reading – PreL2Comp** (English reading comprehension measured by multiple-choice and T/F questions and a recall task in the pretests)

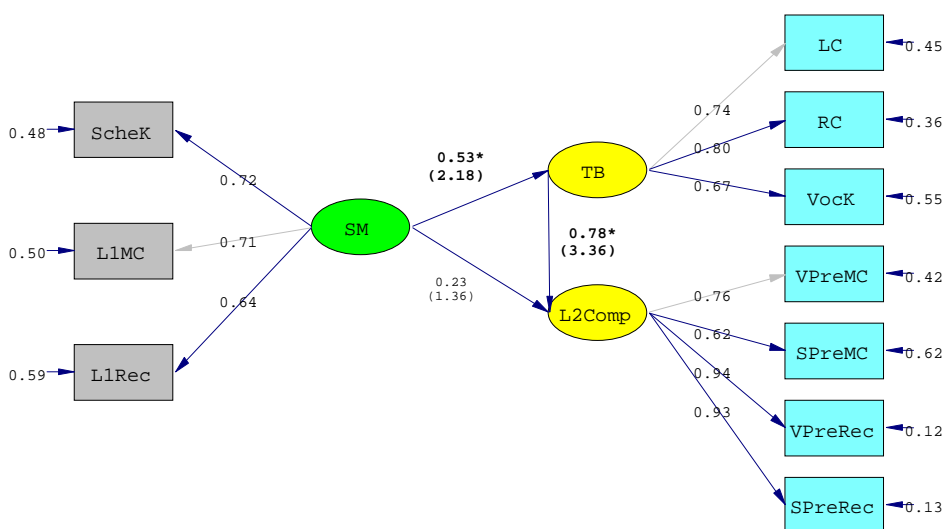

Keys for the terms in the Figure 4.13

- ScheK: the scores on quiz on the schematic knowledge acquisition activity
- L1MC: the scores on Korean reading comprehension measured by multiple-choice and T/F questions
- L1Rec: the scores on Korean reading comprehension measured by a recall task
- SM: latent variable for situation model
- LC: the scores on listening comprehension in TOEIC Bridge
- RC: the scores on reading comprehension in TOEIC Bridge
- VocK: the scores on quiz on the vocabulary knowledge acquisition activity
- TB: latent variable for textbase
- L2Comp: latent variable for English reading comprehension
- VPreMC: the scores on English reading comprehension measured by multiple-choice and T/F questions in the pretest of the vocabulary knowledge acquisition condition
- SPreMC: the scores on English reading comprehension measured by multiple-choice and T/F questions in the pretest of the schematic knowledge acquisition condition
- VPreRec: the scores on English reading comprehension measured by a recall task in the pretest of the vocabulary knowledge acquisition condition
- SPreRec: the scores on English reading comprehension measured by a recall task in the pretest of the schematic knowledge acquisition condition

Figure 4.14 **The Construction Integration Model for L2Reading – PostL2CompMC**
(English reading comprehension measured by multiple-choice and T/F questions in the posttests)

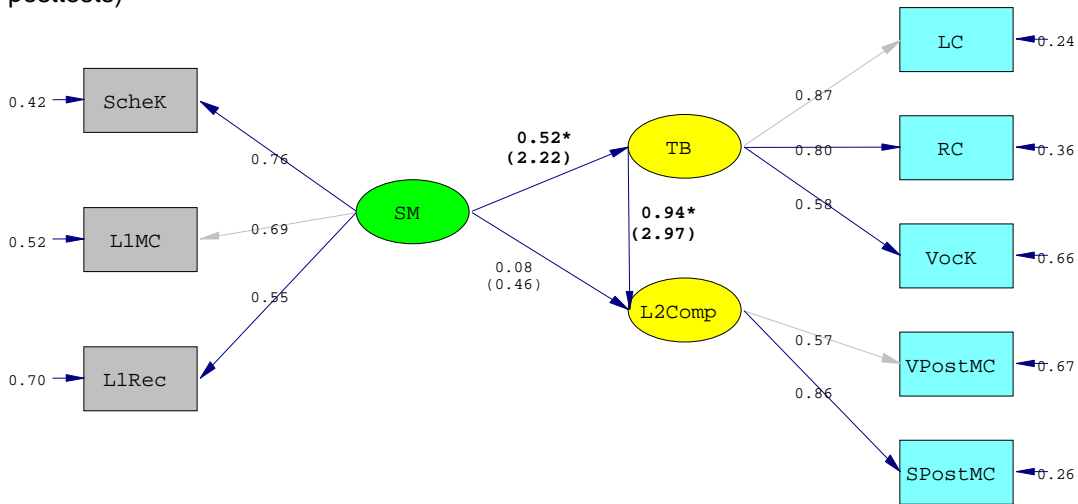

Keys for the terms in Figure 4.14

- ScheK: the scores on quiz on the schematic knowledge acquisition activity
- L1MC: the scores on Korean reading comprehension measured by multiple-choice and T/F questions
- L1Rec: the scores on Korean reading comprehension measured by a recall task
- SM: latent variable for situation model
- LC: the scores on listening comprehension in TOEIC Bridge
- RC: the scores on reading comprehension in TOEIC Bridge
- VocK: the scores on quiz on the vocabulary knowledge acquisition activity
- TB: latent variable for textbase
- L2Comp: latent variable for English reading comprehension
- VPostMC: the scores on English reading comprehension measured by multiple-choice and T/F questions in the posttest of the vocabulary knowledge acquisition condition
- SPostMC: the scores on English reading comprehension measured by multiple-choice and T/F questions in the posttest of the schematic knowledge acquisition condition

Figure 4.15 **The Construction Integration Model for L2Reading – PostL2CompRec** (English reading comprehension measured by a recall task in the posttests)

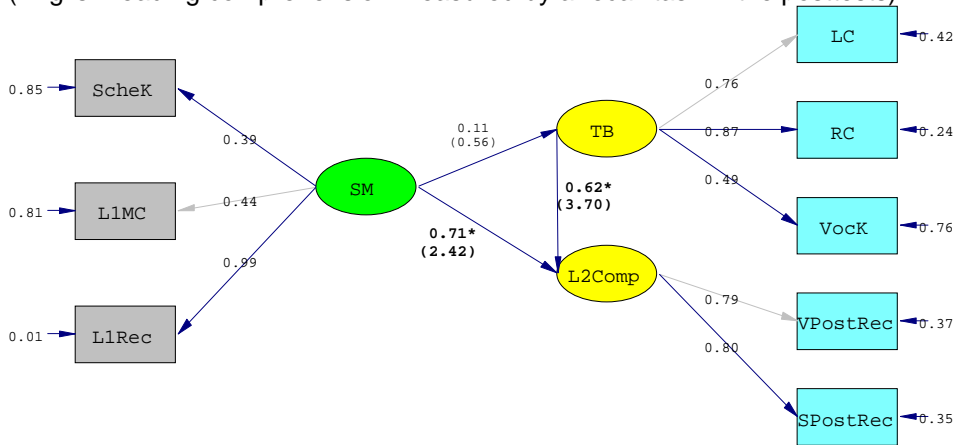

Keys for the terms in Figure 4.15

- ScheK: the scores on quiz on the schematic knowledge acquisition activity
- L1MC: the scores on Korean reading comprehension measured by multiple-choice and T/F questions
- L1Rec: the scores on Korean reading comprehension measured by a recall task
- SM: latent variable for situation model
- LC: the scores on listening comprehension in TOEIC Bridge
- RC: the scores on reading comprehension in TOEIC Bridge
- VocK: the scores on quiz on the vocabulary knowledge acquisition activity
- TB: latent variable for textbase
- L2Comp: latent variable for English reading comprehension
- VPostRec: the scores on English reading comprehension measured by a recall task in the posttest of the vocabulary knowledge acquisition condition
- SPostRec: the scores on English reading comprehension measured by a recall task in the posttest of the schematic knowledge acquisition condition

Table 4.16 **The Construction Integration Model for L2 reading – PostL2Comp** (English reading comprehension measured by multiple-choice and T/F questions and a recall task in the posttests)

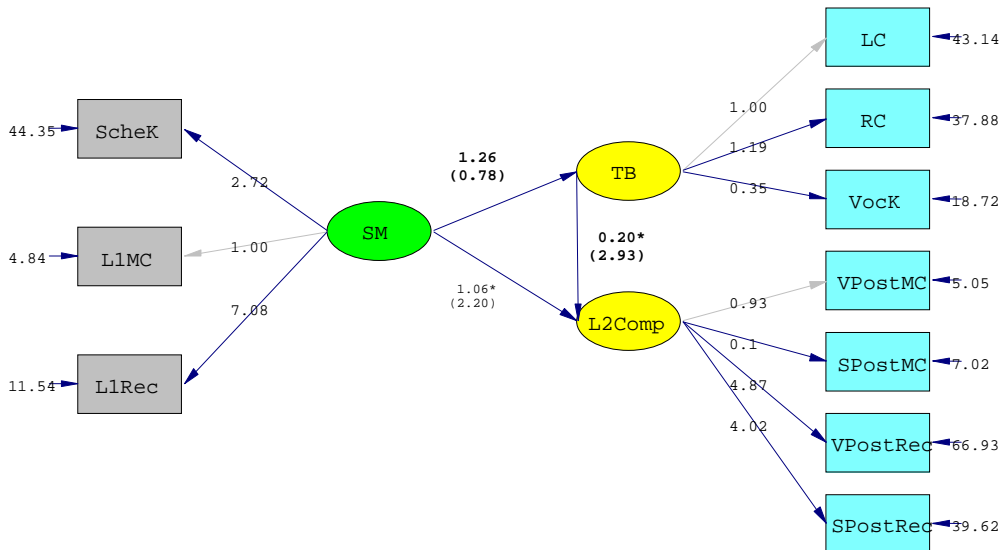

Keys for the terms in the Figure 4.16

- ScheK: the scores on quiz on the schematic knowledge acquisition activity
- L1MC: the scores on Korean reading comprehension measured by multiple-choice and T/F questions
- L1Rec: the scores on Korean reading comprehension measured by a recall task
- SM: latent variable for situation model
- LC: the scores on listening comprehension in TOEIC Bridge
- RC: the scores on reading comprehension in TOEIC Bridge
- VocK: the scores on quiz on the vocabulary knowledge acquisition activity
- TB: latent variable for textbase
- L2Comp: latent variable for English reading comprehension
- VPostMC: the scores on English reading comprehension measured by multiple-choice and T/F questions in the posttest of the vocabulary knowledge acquisition condition
- SPostMC: the scores on English reading comprehension measured by multiple-choice and T/F questions in the posttest of the schematic knowledge acquisition condition
- VPostRec: the scores on English reading comprehension measured by a recall task in the posttest of the vocabulary knowledge acquisition condition
- SPostRec: the scores on English reading comprehension measured by a recall task in the posttest of the schematic knowledge acquisition condition

As indicated in Table 4.13, PostL2CompRec (Figure 4.15) and PostL2Comp(MC&Rec) (Figure 4.16) did not have acceptable values for any of the indices used even though PostL2CompRec had an acceptable P-value for test of close fit (.079; RMSEA < .05; a value larger than .05 indicates close fit). In order to check if the source of poor fit comes from a measurement model or structural model, two different measurement models for PostL2CompRec and PostL2Comp (MC&Rec) were run; (1) VPostRec and SPostRec as indicators for L2Comp and (2) VPostMC, SPostMC, VPostRec, and SPostRec as indicators for L2Comp respectively. The values for different indices indicate that the measurement models have a poor fit; SRMR (0.17); RMSEA (0.14, with 0.01; 0.24 CI₉₀; CFI (0.94) for PostL2CompRec and SRMR (0.16); RMSEA (0.16, with 0.093; 0.23 CI₉₀; CFI (0.91) for PostL2Comp(MC&Rec). Thus, the source of problems appears to be the measurement model rather than the structural model. Since the measurement model for CI model for L2 comprehension (L2 and VocK as indicators for textbase and L1 reading competence and ScheK as indicators for situation model) was good, the

problem lies in the L2 comprehension measures – the scores of posttest in recall.

Taking into account the issues with the goodness of fit indices, the last hypothesis is partially supported because all the fit indices indicated poor model fit for

PostL2CompRec and PostL2Comp(MC&Rec), whereas all the fit indices indicated good model fit for PreL2CompMC and PostL2CompMC, and some of the fit indices were good for PreL2CompRec and PreL2Comp(MC&Rec).

Chapter 5: Discussion

Chapter Five provides interpretations of the results in Chapter Four with respect to each hypothesis tested. In terms of space assigned for each hypothesis, hypothesis one and two are discussed only briefly because the test of these hypotheses is the confirmation of intuitive knowledge of the relationships among variables even though empirical data that support such knowledge is of value. More detailed discussion will be given to the test of hypotheses three, four, and five. The summary of the interpretations of the results is provided in relation to important findings; (1) which cognitive process is responsible for linking L1 reading competence and L2 reading competence, (2) how acquiring different kinds of knowledge (vocabulary knowledge and schematic knowledge) taps into different kinds of competence, L1 reading competence and L2 proficiency in relation to different cognitive processes being taxed, and (3) the Construction Integration Model as a viable model for a comprehensive L2 reading theory. In order to remind the readers of the terms, Table 4.1 is provided here again.

5.1 Hypothesis 1: Treatment Effect

The first hypothesis was confirmed by the significant improvement in comprehension of the post-tests in both the treatment conditions. As CLT (cognitive load theory) has predicted, L2 reading that carries high intrinsic cognitive load due to dual processing demands, linguistic and informational was enhanced by the successful use of advance organizers. Vocabulary knowledge acquisition was proposed to be conducive to processing the information of low element activity, whereas schematic knowledge

Table 4.1. Terms for different measures

Terms	Meaning
L2	the scores on TOEIC Bridge
LC	the scores on listening comprehension in TOEIC Bridge
RC	the scores on reading comprehension in TOEIC Bridge
L1	the composite scores on multiple-choice & T/F questions and recall in the Korean reading test
L1MC	the scores on multiple-choice & T/F questions in the Korean reading test
L1Rec	the scores on recall task in the Korean reading test
VocK	the scores on the quiz on vocabulary knowledge after the vocabulary knowledge acquisition activity
ScheK	the scores on the quiz on schematic knowledge after the schematic knowledge acquisition activity
VPreMC	the scores on the multiple-choice questions & T/F questions in the English text under the vocabulary knowledge acquisition condition before the vocabulary knowledge acquisition activity
VPostMC	the scores on the multiple-choice questions & T/F questions in the English text under the vocabulary knowledge acquisition condition after the vocabulary knowledge acquisition activity
VPreRec	the scores on the recall task in the English text under the vocabulary knowledge acquisition condition before the vocabulary knowledge acquisition activity
VPostRec	the scores on the recall task in the English text under the vocabulary knowledge acquisition condition after the vocabulary knowledge acquisition activity
SPreMC	the scores on the multiple choice questions and T/F questions in the English text under the schematic knowledge acquisition condition before the schematic knowledge acquisition activity
SPostMC	the scores on the multiple choice questions and T/F questions in the English text under the schematic knowledge acquisition condition after the schematic knowledge acquisition activity
SPreRec	the scores on the recall task in the English text under the schematic knowledge acquisition condition before the schematic knowledge acquisition activity
SPostRec	the scores on the recall task in the English text under the schematic knowledge acquisition condition after the schematic knowledge acquisition activity
CPreMC	the scores on the multiple-choice questions & T/F questions in the English text under the control pretest condition
CPostMC	the scores on the multiple-choice questions & T/F questions in the English text under the control posttest condition
CPreRec	the scores on the recall task in the English text under the control pretest condition
CPostRec	the scores on the recall task in the English text under the control posttest condition

acquisition was proposed to be facilitative to processing the information of high element activity. Despite this qualitatively different processing or knowledge feature,

the improvement in L2 comprehension measured with multiple choice and true/false questions and recall was uniformly significant. In order to examine whether the comprehension brought about by each treatment condition has qualitatively different features, the results from hypotheses two and four need to be considered.

5.2 Hypothesis 2: Associations of Variables (L2 proficiency, L1 reading competence, vocabulary knowledge acquisition, and schematic knowledge acquisition)

The second hypothesis investigated what contributes to the acquisition of different types of knowledge. As the CI model for L2 reading has predicted (L1 reading competence is associated with individual differences in schematic knowledge that belongs to a situation model, whereas L2 proficiency is associated with vocabulary knowledge that belongs to a textbase), individual differences in L1 reading competence made a significant difference in the acquisition of schematic knowledge, and L2 proficiency was a significant predictor for the acquisition of vocabulary knowledge; refer to Figure 4.2 and 4.3 for specific loadings. The finding supports the claim that the significantly improved comprehension in the post-tests was indeed brought about by different kinds of competences realized in two treatment types respectively.

5.3 Hypothesis 3: Test of Linguistic Threshold Hypothesis (Cummins, 1979)

The third hypothesis explored what the previous research had found, the linguistic threshold effect. The present study looked into L1 reading competence and L2 reading comprehension in a finer-grain size in that two different kinds of measures

(multiple choice and true/false questions and recall) were used to measure L1 and L2 reading comprehension, which indeed showed different patterns. The Linguistic Threshold Hypothesis (Cummins, 1979) was confirmed in the three models, (1) L1MC (Korean reading comprehension measured by multiple-choice and T/F questions) with L2CompMC (English reading comprehension measured by multiple-choice and T/F questions) in the pretest conditions, (2) L1MC with L2CompRec (English reading comprehension measured by a recall task) in the pretest conditions), and (3) L1Rec (Korean reading comprehension measured by a recall task) with L2CompMC because L2 proficiency was the only significant predictor for L2 reading comprehension, even though L1MC had a significant indirect effect upon L2Comp via L2. However, in the model of L1Rec with L2CompRec, both L1Rec and L2 were significant predictors for L2CompRec even though the magnitude of loading in L2 is bigger than that of L1Rec in all three conditions, VPreRec, SPreRec, and CPreRec; refer to the Figure 4.7 for specific values. Thus, the result found in the recall model is interpreted as the stage where L1 reading competence begins to come into play.

What needs to be elaborated in terms of interpretation is the fact that different measures produced different patterns. The proposed theory maintains that the situation model is a function of L1 reading competence, whereas the textbase is a function of L2 proficiency. Even though this simplification makes it clear how L1 reading competence is related to L2 reading comprehension, providing a global perspective on how this complex cognitive phenomenon of L2 reading comprehension takes place, neither L1 reading competence nor L2 reading comprehension can be perceived as a unidimensional construct. This argument is

indeed confirmed by the different patterns found among the variables (L1 reading competence, L2 proficiency, and L2Comp) and the measures (MC and Rec) in the analysis.

In the present study, latent constructs of L1 reading competence and L2 reading comprehension were operationalized in the form of multiple-choice and true/false questions and a recall task. Figuring out what distinct abilities are taxed in each measure will illuminate what cognitive processes are involved. Identifying a cognitive process that plays a significant role in L1 and L2 reading comprehension will then help us clarify how L1 reading competence becomes functional in comprehending an L2 reading text. Since L1Rec with L2CompRec showed a different pattern (not only L2 proficiency but also L1Rec was a significant predictor for L2 reading comprehension measured by a recall task) from the other three models, L1MC with L2CompMC, L1MC with L2CompRec, and L1Rec with L2CompMC (L2 proficiency was the only significant predictor for L2 reading comprehension), understanding what cognitive process is taxed in a recall task can illuminate a link between L1 reading competence and L2 reading comprehension.

To come up with good responses to a recall task, readers need to remember a given text as much as possible, which easily tricks us to think that recall is a task of mere memory. However, considering humans' limited capacity of working memory, what makes readers remember the contents of the approximately –200 – 300 word-long text is not simple working memory capacity but rather an ability to organize information or micropropositions into coherent macropropositions, which recursively subsume or anchor micropropositions to the long-term working memory for the task

of recall. Therefore, it appears that recall relies heavily on an ability to build coherent macropropositions after the construction of textbase and to use them as a guiding structure for elaborating and retrieving propositions from their memory for the task of recall.

When it comes to multiple-choice and true/false questions, the focus appears to shift toward an ability to evaluate micropropositions and macropropositions depending on the types of questions. Unlike the recall task, readers can refer back to the text whenever they need, which weakens the role of remembering the contents and thus does not capitalize on an ability to build coherent macropropositions to a great degree. As a precaution, what is argued here should not be perceived as saying that coherent macropropositions are not important in the task of multiple-choice and true/false questions but that they are relatively less important in multiple-choice and true/false questions than in a recall task. What is critical in providing good responses to multiple-choice and true/false questions is an ability to evaluate pieces of information given in the questions in relation to the mental representation that readers build from a given text concerning whether given propositions in the questions are true or false and which propositions or words answer given questions correctly.

L2 proficiency was the only significant predictor for L2Comp in the three models (L1MC with L2CompMC, L1MC with L2CompRec, and L1Rec with L2CompMC), which confirmed the linguistic threshold hypothesis. That is, there was no significant direct contribution of L1MC to L2 reading comprehension. However, there was significant indirect effect of L1MC to L2Comp via L2 proficiency. This illuminates what kinds of L1 reading competence play a significant role in relation to

L2 proficiency to explain L2 reading comprehension. That is, it is not L1Rec but L1MC (an ability to evaluate propositions in questions for truthfulness based on the situation model built from the main text) that shares a significant variance with general proficiency in L2, which feeds into both L2CompMC and L2CompRec. Whether L1MC can have a significant direct effect to L2 reading comprehension or stays the same (only indirect effect via L2) as L2 proficiency improves needs to be explored further with participants of more advanced L2 proficiency.

To the contrary, the indirect effect of L1Rec to L2CompMC and L2CompRec is trivial in all three conditions of VocPre, SchePre and ConPre regardless of the L2Comp measures. This indicates that an ability to form macropropositions that efficiently subsume details for a recall task does not share common variance with L2 proficiency. In addition, L1Rec was not a significant predictor for either L2CompMC or L2 proficiency in the model of L1Rec with L2CompMC. Instead, L1Rec has a significant direct effect on L2CompRec in the model of L1Rec with L2CompRec; the loadings from L1Rec to L2CompRec were .41* (3.13) for VPreRec, .38* (3.23) for SPreRec, and .54* (4.17) for CPreRec respectively. In some sense, it may well be the case because the task of L2CompRec was done in Korean except for several students (twenty four students recalled in Korean; five students recalled in Korean and English; and three students recalled entirely in English). Furthermore, it may come with no surprise that those who are good at L1Rec become good at recalling their situation model in L1, which was a translated and elaborated version of the English textbase. Even though this explanation appears to be somewhat self-evident, incorporating this cognitive phenomenon into a broader L2 reading comprehension

provides invaluable insight into via what kinds of routes L1 reading competence gets transferred to L2 reading competence and how.

Previous studies (Leontiev, 1981; Cohen, 1998; Guerrero, 2005) have found that L2 readers translate textbase into their native language and elaborate it with their background knowledge that exists in their L1, thus, thinking in L1. It is not until a fairly advanced level of L2 proficiency that they start manipulating propositions and thinking in L2. Those with less L2 proficiency cannot help but resort to their L1Rec or thinking in L1 because textbase translated into L1 is elaborated in their L1 as well, where an ability to form good macropropositions in L1 is transferred to L2CompRec. This is indeed confirmed by a significant direct effect of L1Rec on L2CompRec. However, L2CompRec is also significantly predicted by L2 proficiency; $.66^*$ (4.19) in VPreRec, $.73^*$ (4.69) in SPreRec, and $.59^*$ (4.13) in CPreRec. This indicates that even though good L1Rec significantly contributes to good responses in the task of recall, good L2 proficiency is still an essential element at this level of L2; this comes with no surprise because building a textbase in L2 is still a prerequisite before translating it into L1 and elaborating it with background knowledge in L1.

Languages involved during the process of L2 reading comprehension can indirectly be addressed by the research on L2 vocabulary acquisition. Jiang (2000) explicated that a lexical entry in L1 contains semantic, syntactic, morphological, and formal (phonological and orthographic) specifications; the first two are named lemma and the last two, lexeme. According to Jiang, during the initial stage called **formal stage of lexical development**, L2 learners pick up only formal specifications (phonological and orthographic), which forces L2 learners to activate L1 translation

equivalents to access concepts. This is most likely to be the stage that most of the participants in the present study are in because they recalled the English texts in Korean rather than in English indicating that accessing concepts (semantic and syntactic) through Korean is easier than accessing them via English. Those who recalled in English (three students entirely in English and five in Korean and English) are likely to be the ones that moved beyond the formal stage of lexical development.

Jiang (2000) explained that the second stage, called **the L1 lemma mediation stage**, allows L2 readers to simultaneously activate L2 word forms and the lemma information (semantics and syntax), which “may result in a strong and direct bond between an L2 word and the lemma of its L1 translation” (p. 52). Thus, L2 word recognition (orthography and phonology) is linked directly to concepts as well as to its L1 translation equivalent at this stage. For example, when the orthography and phonology of the word “*photosynthesis*” is recognized, its Korean equivalent translation, “*GyuanHabSung*” is instantly activated, and the concept of the word is understood, a reader is deemed to stay at the formal stage. However, if the step of understanding can simultaneously come with the activation of Korean equivalent translation, indicating that L2 readers simultaneously activate L2 word forms and the lemma information, a reader can be placed in the L1 lemma mediation stage.

The full development of lexical competence is realized at the third stage, **L2 integration stage**. During this stage, L2 learners can activate concepts (semantic specification) directly without any mediation of L1 when they recognize words in L2 with complete activation of morphological information. Thinking in L2 is most likely to happen at this stage. However, since thinking entirely in L2 involves adopting L2

syntax such as word order to integrate activated concepts in L2, we may not be able to predict that thinking in L2 during L2 reading comprehension would take place at the **L2 integration stage**.

Based on the model of lexical development, it may be possible that some of 24 participants who recalled entirely in Korean are at the second stage of the L1 lemma mediation because even though they may have simultaneously activated the lemma information along with Korean translation equivalents, the recall task may have required the use of a production skill, writing. Since the nature of the task requires the use of L2 word order if the participants want to recall in English, which may be too challenging, they may have suppressed a direct link of L2 words to the lemma but went back to the L1 translation equivalents. Yet, the participants who recalled in Korean used L2 words sporadically in their writing of their recall. This may serve as evidence that the participants are at the second stage of lexical development.

Another study that indirectly informs the nature of thinking in L2 during the process of L2 reading comprehension was examined by Juffs (2004). Juffs (2004) compared different reading times of L2 learners with different L1 profiles (Chinese, Japanese, and Spanish) and native speakers of English after asking them to process garden path sentences (i.e., After the children cleaned the house looked very neat and tidy.). Since the verb, 'cleaned' can be either intransitive or transitive, when readers are encountered with the noun, 'house', they tend to chunk the 'house' with the verb 'cleaned.' But when they see a verb, 'looked,' they soon realize that the noun, 'house' is not an object of a verb 'cleaned' but a subject of a verb 'looked.' Thus,

they rearrange chunking of words, which requires them to parse a given sentence correctly. Reading times at the point of the word, 'looked,' consistently increased across all language groups presumably due to rechunking of words. However, L2 readers consistently spent more time than native speakers of English, and Japanese speakers whose L1 belongs to a class of pro-drop language (or null subject languages) and SOV word order spent more reading time on the verb 'looked' than any other language groups did. Juffs (2004) interpreted the similar trajectories of reading times at different word points found among L2 learners with different L1s and native speakers of English as the evidence for the same mechanism taking place but only slowly for L2 readers.

The study also showed that L1 readers did not spend more reading time at the verb, 'arrived' and 'asked' in a non-garden-path sentence (i.e., 'After the student arrived the professor asked her about her trip. '), while L2 readers spent more reading time at these verbs. This indicates that L2 readers may have less complete information about the features of the verbs, 'arrived' and 'asked' and assigning relationships between the 'student' and 'arrived' and between the 'professor' and 'asked' may have cost L2 readers more reading time. Similarly, Juffs (2004) concluded that "the data do hint that L2 learners have special problems with verbs overall" (p. 220). The focus of the study was more on a micro-level analysis on the influence of one syntactic feature (transitivity of a verb) and different first languages of L2 learners upon parsing: similar trajectories of reading time at different word points in a garden-path sentence were found across L2 readers of different L1s and L1 readers, but consistently slower reading time from L2 readers and similar trajectories

of reading time at different word points in a non-garden-path sentence was found only among L2 readers. Based on the findings, it was concluded that parsing mechanisms are similar but are more challenging for L2 readers, and the problem appears to be caused by processing verbs rather than nouns.

These findings by Juffs (2004) indirectly inform us of thinking in L2 during on-line L2 reading comprehension; specifically, two aspects of the study (comprehension vs. production skills and a unit of measurement in the study) help us infer the nature of thinking in L2 in terms of cognitive demands placed on L2 readers. Verbs assign relationships among nouns that carry crucial information (what or who an agent and a receiver of given verbs are), and transitivity of a verb and specific location of an agent and a receiver for a certain verb can differ across languages. Thus, the observation that L2 readers tend to have more problems in processing verbs than nouns makes sense. What needs to be noted in relation to thinking in L2 is that this problem was observed in a task for comprehension, which requires relatively less cognitive resources than a task for production. Constructing textbase from a given sentence requires comprehension skills like the one used in the Juff's (2004) study. However, thinking in L2 requires L2 readers to integrate constructed textbase or numerous microstructures into a coherent mental representation by resetting their default processing mechanisms for production (even though it may not be in a grammatically complete form), which uses up a great deal more cognitive resources than comprehension. This requires L2 readers to clearly understand the relationships among words not only within one sentential boundary but also across numerous

sentences and to have automatic access to the rules of the target language if thinking in L2 is to take place.

Concerning the unit of measurement, reading times were measured by a unit of milliseconds, and a unit of language to be processed was one sentence that has two clausal features (two verbs involved) in the Juffs' study (2004). Even at this fine level, L2 readers' processing performance was significantly different from that of L1 readers. When the unit of analysis for language to be processed becomes a discourse level, and the temporal unit becomes minutes rather than milliseconds, the cognitive demands placed on L2 readers for processing non-L1 reading text can exponentially increase. Thus, under the assumption of limited cognitive resources, thinking in L2 during the process of on-line L2 reading comprehension is the task that carries an extremely high cognitive load.

To sum up, the linguistic threshold effect held strong in the three models, L1MC with L2CompMC, L1MC with L2CompRec, and L1Rec with L2CompMC; the direct effects of L1MC to L2CompMC, L1MC to L2CompRec, and L1Rec to L2CompMC were not significant in all three conditions of CPre, VPre and SPre; and there was only a significant indirect effect of L1MC to L2CompMC and L2CompRec via L2. This indirect significant effect to L2Comp via L2 proficiency was interpreted that an ability to evaluate propositions in questions in relation to mental representation built from a given text in L1 shares significant common variances with L2, which then feeds into L2 Comp. This is the variance explained by L1MC via L2 in addition to the unique variance directly explained by L2.

However, the linguistic threshold effect was weakened in the model of L1Rec with L2CompRec in the sense that L1Rec was a significant predictor for L2CompRec along with a stronger predictor, L2. Based on this finding, it was suggested that the cognitive process that a recall task measures is one of the ways that L1 reading competence emerges as an influential factor for L2 reading comprehension. Since forming macropropositions involves a thinking process, which addresses a situation model, a condition for thinking in L2 to take place during the process of on-line L2 reading comprehension was elaborated in relation to the research on L2 vocabulary acquisition (Jiang, 2000) and the findings on sentence processing in L2 (Juffs, 2004). To understand how this process takes place, we need more fine-grained levels of research both qualitatively and quantitatively. What we can anticipate from this global pattern is that it is plausible that as L2 proficiency improves, L1Rec may become more influential in L2CompRec to the extent that L2 proficiency becomes not significant, and L1MC may begin to have its own direct significant effect on L2Comp. The former prediction is addressed partially in the next hypothesis in the study. It is stated as a partial exploration in that participants were assumed to improve their L2 proficiency after the vocabulary knowledge acquisition activity but to stay the same in terms of differential degrees of automatic retrieval of declarative vocabulary knowledge and syntactic knowledge.

5.4 Hypothesis 4: Effect of Different Kinds of Knowledge

The fourth hypothesis investigated the differential effect of treatment types upon different measures of L2 reading comprehension. The differential effects of

treatment types were shown in the change of the proportion of the variances in L2 reading comprehension that L2 proficiency and L1 reading competence account for. The general patterns found are that **the acquisition of vocabulary knowledge decreased the dependence on L2** consistently in all the four models, L1MC (Korean reading comprehension measured by multiple-choice and T/F questions) with L2CompMC (English reading comprehension measured by multiple-choice and T/F questions), L1MC with L2CompRec (English reading comprehension measured by a recall task), L1Rec (Korean reading comprehension measured by a recall task) with L2CompMC, and L1Rec with L2CompRec, whereas **the acquisition of schematic knowledge increased dependence on L2** in the models of L1MC with L2CompMC and L1Rec with L2CompMC but **decreased dependence on L2** in L1MC with L2CompRec and L1Rec with L2CompRec; refer to Tables 4.10 – 4.12 for the summary of the changes in the loadings from pre-tests to post-tests.

The interpretation of the pattern found in **the Vock acquisition condition** is consistent with the proposed CI model for L2 reading comprehension. According to the CI model for L2 reading, the construction of textbase is a function of L2 proficiency, and as L2 proficiency increases, building the textbase becomes easier, which in turn lessens the impact of individual differences in L2 proficiency. This has been addressed via the Linguistic Interdependence hypothesis (Cummins, 1979), which states that L1 reading competence becomes a stronger predictor for L2 reading comprehension at an advanced level of L2 proficiency; in other words, L2 becomes a less important predictor. In this study, the acquisition of vocabulary knowledge is hypothesized to bring about enhanced L2 proficiency, which makes it easier to build

the textbase. An impoverished textbase, which is the state before the VocK activity, offers more room for individual differences in L2 to be manifested. On the other hand, enhanced textbase, which is the state after the VocK activity, is likely to shrink a space where individual differences in L2 can reveal themselves. The consistently decreased effect of L2 in all the L2Comp measures in VPost is consistent with this interpretation.

According to the proposed CI Model for L2 reading comprehension, increased L2 proficiency should result in not only the decreased dependence on L2 proficiency but also increased dependence on L1 reading competence because well-constructed textbase does not need to tax abilities related to L2 proficiency but instead, an ability that is related to constructing a situation model, thus L1 reading competence. The latter is supported by the results of the model, **L1Rec** with L2CompMC and **L1Rec** with L2CompRec but not by the results of the models, **L1MC** with L2CompMC and **L1MC** with L2CompRec. As discussed in connection with hypothesis three, different features in the tasks of multiple-choice and true/false questions and recall induce different kinds of cognitive activities. Since L2 readers with lower proficiency tend to build textbase and situation model in their L1, it was suggested that the task of recall was completed in participants' L1, which is Korean except for the three students who recalled entirely in English. An ability to organize coherent macropropositions measured in the task of recall in L1 was a significant predictor in the L2CompRec for pretests; .41* in VPreRec and .38* in SPreRec, while L1MC in both types of L2Comp and L1Rec in L2CompMC were not significant in all three

conditions (CPre, VPre, and SPre). This was interpreted as the confirmation of the Linguistic Threshold Hypothesis (Cummins, 1979).

Now, after the VocK acquisition activity or with the enhanced textbase due to the newly acquired vocabulary knowledge, what is observed is that the magnitude of the loading in the path from L1Rec to L2CompMC/Rec increased; from .11 in VPreMC to .28 in VPostMC and from .41* in VPreRec to .57* in VPostRec. This indicates that dependence on L1 reading competence, specifically L1Rec, has increased due to the enhanced textbase, which the VocK acquisition activity supposedly brings about. The bottleneck effect of L2 proficiency was loosened to the extent that L1 reading competence can be brought to bear and begins to play a more influential role.

Therefore, the proposed theory is instantiated with the findings of the study. That is, the construction of textbase is a function of L2 proficiency. The increased L2 proficiency via vocabulary knowledge activity lowered the dependence on L2 proficiency but boosted the dependence on L1 reading competence, specifically, L1Rec. This ability manifested in L1Rec belongs to situation model building capability, in the sense that an ability to organize numerous micropropositions into several macropropositions and use them as a guiding tool for recall addresses the cognitive processes of synthesizing propositions from textbase and integrating them with background knowledge to come up with a few condensed propositions. Therefore, the initial route through which L1 reading competence contributes to L2 reading comprehension is L1Rec, which is an indicator of the situation model variable. L1MC appears to be insensitive to the degree of change in L2 induced by

the acquisition of VocK only because the significant indirect effect of L1MC to L2CompMC and L2CompRec stayed the same along with no significant direct effect.

As far as **the ScheK acquisition condition** is concerned, the path diagrams show that the dependence on L2 noticeably increased in the L1MC with L2CompMC (from .72* to .83*) and L1Rec with L2CompMC (from .69* to .80*), whereas the dependence on L2 noticeably decreased in L1MC with L2CompRec (from .71* to .40*) and L1Rec with L2CompRec (from .73* to .48*). One thing that needs to be noted is that the model fit in the ScheK acquisition condition was good only for the L1MC with L2CompMC although the P values for the test of close fit in RMSEA are good in other models (L1MC with L2CompRec, L1Rec with L2CompMC, and L1Rec with L2CompRec). P value for the test of close fit is 0.073 for L1MC with SPostRec, .21 for L1Rec with L1Rec with SPostMC, and .21 for L1Rec with SPostRec when a value for statistically close fit is $RMSEA > .05$. In addition, the focus of the analysis is not to evaluate goodness of fit for these models but to see the change of magnitude that L2 proficiency and L1 reading competence explain after the schematic knowledge acquisition. Still, the interpretation of the patterns found in the three models (L1Rec with SPostMC, L1Rec with SPostMC and L1Rec with SPostRec) should be taken with caution.

The quality of the mental representation of a given text before and after the acquisition of ScheK is presumed to reflect an impoverished textbase due to the lack of L2 proficiency. What is expected to happen in this condition is that students' situation model improves due to the intervention to the extent to which the holes in impoverished textbase get filled with or compensated for by enriched situation model.

This may consequently induce the construction of better textbase at the level of top-down process but not at the level of bottom-up process.

The contrast of the change in the variance that L2 explains in different measures, L2CompMC and L2CompRec, informs us of how an enhanced situation model with limited L2 proficiency plays a role in the process of L2 reading comprehension at a finer level. The only change observed in the model of L1MC with L2CompMC and the model of L1Rec with L2CompMC after the acquisition of ScheK is the increased dependence on L2 except the additional treatment effects, which failed to reach a significant level in both conditions – .20 (1.53 of Z score) in L1MC with L2CompMC and .19 (1.48 of Z score) in L1Rec with L2CompMC.

According to the proposed theory, the impoverished textbase in this condition is expected to be improved through the use of the enriched situation model at the level of top-down process. The elaborated mental representation of a text after the acquisition of ScheK is measured with multiple-choice and true/false questions, which tax an ability to evaluate propositions built from the questions in relation to those built from the main text. Since the questions in multiple-choice and true/false questions were given in English, another step of building a textbase for propositions in the questions is required. Unlike the enhanced textbase after the acquisition of VocK, which is expected to be fairly stable because it was built directly at the bottom-up level and VocK is directly transferable to the building of textbase of the questions, the enhanced textbase in the ScheK acquisition condition may not be as stable because the holes in the textbase were not filled with immediate VocK but with inferences based on the enriched situation model. This means that a different

arrangement of propositions in English in the questions from those in the main text poses a challenge of building another textbase in English without any additional help. Faced with another kind of impoverished textbase but with a better situation model on the main text and the demand on evaluating this impoverished textbase of the questions in relation to the enriched situation model built from the text in L2, the room where individual differences in L2 proficiency come into play is likely to be expanded, thus magnifying the role of L2.

However, the task of Rec does not require readers to build any kind of additional textbase, but to make use of enriched situation model directly. Since the textbase built from the main text was guided by enriched situation model (schematic knowledge) in L1 rather than vocabulary knowledge, which facilitates a bottom-up process in L2, and the task of recall allows readers to manipulate propositions in their L1 freely at this level of L2 proficiency, individual differences in L2 do not have to get taxed to a great degree. Instead, L1Rec emerges as the most influential factor, which is the pattern observed in the result; the loading from L1Rec to L2CompRec changed from .38* in the SPreRec to .54* in the SPostRec, whereas the loading from L2 to L2CompRec changed from .73* in SPreRec to .48* in SPostRec. Note that L1Rec becomes even a stronger predictor than L2 proficiency in the posttest of the schematic knowledge acquisition condition.

To summarize, since textbase construction is proposed to be a function of L2 proficiency, which includes L2 vocabulary knowledge, the acquisition of vocabulary knowledge is supposed to improve textbase construction. As the findings of previous research (Carrel, 1991; Bossers, 1991; Bernhardt & Kamil, 1995; Brisbois, 1995)

showed, improved L2 proficiency should decrease dependence on L2 proficiency but increase dependence on L1 reading competence. The finding observed in the present study confirms this predicted pattern; with the enhanced textbase, due to the acquisition of vocabulary knowledge, the role of L2 proficiency became weaker, whereas the role of L1 reading competence (specifically, L2CompRec) became more important. As argued in the previous section (discussion on the hypothesis three), the cognitive process that a recall task taxes is reflected by the path through which L1 reading competence becomes functional in the process of L2 reading comprehension. Since the cognitive process that requires L2 readers to form macropropositions and use them as anchoring tools for efficient recall entails thinking, which could take place in readers' L1 or L2 depending on their proficiency, this particular cognitive process addresses a situation model. Considering the observation that recall is a path that links L1 reading competence with L2 reading comprehension, and the cognitive process that a recall task involves can be explained by a situation model, the finding corroborates the proposed theory, the CI model for L2 reading comprehension; that is, textbase construction as a function of L2 proficiency, and situation model construction as a function of L1 reading competence.

The increased dependence on L2 proficiency in the schematic knowledge acquisition condition (the models of L1MC with L2CompMC and L1Rec with L2CompMC) also confirms the CI model for L2 reading comprehension; a textbase as a function of L2 proficiency and a situation model as a function of L1 reading competence. According to the prediction based on the proposed model, the acquisition of schematic knowledge is not supposed to enhance textbase to a great

degree but enriches a situation model because schematic knowledge belongs to L1 reading competence rather than L2 proficiency, and L1 reading competence and schematic knowledge are proposed to contribute to the construction of a situation model. How increased schematic knowledge affects L2 reading comprehension in relation to L2 proficiency has not yet been investigated in the previous research. Thus, the findings on the effect of increased schematic knowledge in relation to L2 proficiency are new to the field.

What was found in the present study is that the enriched situation model with relatively impoverished textbase due to only the acquisition of schematic knowledge have the same pattern as the one found in the pretests of all three conditions (vocabulary knowledge acquisition, schematic knowledge acquisition, and control) where the Linguistic Threshold Hypothesis (Cummins, 1979) was partially confirmed. Just to remind readers of the pattern found in the hypothesis three, the models of L1MC with L2CompMC, L1MC with L2CompRec, and L1Rec with L2CompMC have L2 proficiency as the only significant predictor, whereas the model of L1Rec with L2CompRec has both L1Rec and L2 proficiency as significant predictors for L2CompRec. The only difference between the scores of the pretests and the scores of the posttests after the schematic knowledge acquisition is the change in magnitude of influence in terms of L2 proficiency and L1Rec. That is, even though the pattern found after the acquisition of schematic knowledge is the same as the pretest conditions (L2 proficiency as the only one significant predictor for three models and L1Rec and L2 proficiency as significant predictors for one model), the role of L2 proficiency considerably increased in the models of L1MC with

L2CompMC and L1Rec with L2CompMC and considerably decreased in the models of L1MC with L2CompRec and L1Rec with L2CompRec, but the role of L1Rec increased only in the model of L1Rec with L2CompRec.

The same pattern found after the acquisition of schematic knowledge as the pattern in the pretest conditions serves as evidence for two distinct constructs of textbase as a function of L2 proficiency and a situation model as a function of L1 reading competence. The schematic knowledge which has a distinct feature from vocabulary knowledge and belongs to L1 reading competence and contributes to building a situation model did not influence the construction of the textbase to a great degree because the findings showed the same pattern of the linguistic bottleneck effect (partial confirmation of the Linguistic Threshold Hypothesis). However, it significantly improved the comprehension in the posttest (confirmation of the hypothesis one). This significant improvement in comprehension is explained by the increased roles of L2 proficiency and L1Rec in different models of analysis. This interpretation may challenge the linguistic threshold effect to some degree because increased schematic knowledge in fact successfully compensated for the impoverished textbase created by the lack of L2 proficiency as shown in the significant improvement in comprehension in the schematic knowledge acquisition condition. However, what happens is that even though the textbase constructed in the schematic knowledge acquisition condition did not improve at a bottom-up level with specific linguistic knowledge, it is likely that the textbase has improved due to inferencing made by the enriched situation model at a top-down processing level. This kind of textbase did not allow the anticipated pattern based on the previous

research (the Linguistic Threshold Hypothesis, Cummins, 1979; and the Linguistic Interdependence Hypothesis, Cummins, 1981) to emerge because it had the same pattern as what was found in the pretests. Instead, it showed an interesting contrast in terms of what is taxed in different kinds of measure or cognitive processes. L2 proficiency plays an even more important role in improving comprehension in L2CompMC, whereas L1Rec comes a more significant contributor to explain L2CompRec, and L1Rec does not have any impact on explaining the variances for L2CompMC.

5.5 Hypothesis 5: Fit indices

The last hypothesis tested the validity of the proposed theory, using the theoretically extracted indicators for two theory-based constructs, textbase and situation model, and various combinations of L2 reading comprehension. With the pre-test data, the model appears to be good in all three conditions, whereas the post-test data indicates that L2CompMC (English reading comprehension measured by multiple-choice and T/F questions) model is the only one that has a good model fit. One possible reason for poor fit with the post-test data may be due to the fact that individual differences in vocabulary knowledge and schematic knowledge are not directly reflected in the scores of the post-tests. Since the participants were allowed to refer to the instructional materials while taking the post-tests – the list of vocabulary with Korean translation if they received a vocabulary acquisition activity and the concept map with all the blanks filled with answers if they received a schematic knowledge acquisition activity, the scores of the post-tests may not

associate with the individual differences in the scores of the vocabulary knowledge and schematic knowledge. This may have resulted in the poor fit of the models.

To examine this speculation, another model was run, the model of L2CompRec without the scores of vocabulary knowledge and schematic knowledge. The goodness of fit indices became acceptable except SRMR; $\chi^2 = 6.71$ ($df = 7, p = 0.46$); SRMR = 0.11; RMSEA = 0.0 CI₉₀: (0.0, 0.21); CFI = 1 (target values to retain a model are SRMR < 0.08, RMSEA < 0.06, CFI \geq 0.95). This result suggests that the scores of vocabulary knowledge and schematic knowledge were one of the main sources of poor fit in the model with these scores included. However, this speculation needs more empirical confirmation from the measurement point of view.

5.6 Summary of the Hypotheses

To summarize, the proposed extension of the Construction Integration model (Kintsch, 1998) for L2 (second language) reading comprehension has been largely supported by the experimental data from the present study along with the confirmation of the findings from the previous research on the roles of L1 (first language) reading competence and L2 proficiency framed within the Linguistic Threshold Hypothesis (Cummins, 1979) and the Linguistic Interdependence Hypothesis (Cummins, 1981). The two latent constructs, (construction of) a textbase as a function of L2 proficiency, and (construction of) a situation model as a function of L1 reading competence, were validated by the good model fit of the measurement model, three indicators namely L1MC (Korean reading comprehension measured by multiple-choice and T/F questions), L1Rec (Korean reading comprehension measured

by a recall task), and ScheK (the scores of quiz on the schematic knowledge acquisition activity) for the situation model and three indicators namely LC (the scores of listening comprehension in TOEIC Bridge), RC (the scores of reading comprehension in TOEIC Bridge), and VocK (the scores of quiz on the vocabulary knowledge acquisition activity) for the textbase, with one error covariance between VocK and ScheK, forced by the modification indices of the LISREL. The associations of VocK with textbase and ScheK with situation model were further confirmed by the result of the hypothesis two; L1 reading competence becomes a stronger predictor for the ScheK acquisition, and L2 becomes a stronger predictor for the VocK acquisition.

The Linguistic Threshold and Interdependency Hypotheses were also confirmed by the result of the hypothesis three. The three models, which include L1MC with L2CompMC (English reading comprehension measured by multiple-choice and T/F questions) and L2CompRec (English reading comprehension measured by a recall task) and L1Rec with L2CompMC, showed that L2 is the only significant predictor for L2 reading comprehension. What was illuminated by the present study on the two hypotheses is that L1Rec is the area where L1 reading competence begins to play a significant role in L2 reading comprehension because L1Rec was a significant predictor for L2CompRec even though L2 was a stronger predictor. L1MC was also concluded to be the construct that shares significant common variances with L2 proficiency itself. That is, the route that L1MC plays a role in L2 reading comprehension is indirect via L2 proficiency. Thus, there were different patterns observed in the roles of L1MC and L1Rec; significant direct

contribution of L1Rec to L2CompRec but no direct contribution to L2 itself and no significant direct contribution of L1MC to L2CompMC and L2CompRec but significant indirect contribution of L1MC to L2CompMC via L2.

This study also examined cognitive processes engaged by each measure. MC measures an ability to evaluate pieces of information given in the questions in relation to the mental representation that readers build from a given text concerning whether propositions in the questions are true or false and which propositions or words answer given questions correctly, whereas recall measures an ability to build coherent macropropositions after the construction of textbase and to use them as a guiding structure for elaborating and retrieving propositions from their memory for the task of recall. An ability to form coherent macropropositions in L1 was shown to be directly transferable to the L2 recall task because thinking took place in L1, which was confirmed by the significant loading from L1Rec to L2CompRec. This ability was still less important than L2, which had a larger loading than the loading from L1Rec to L2CompRec; .41* vs. .66* in VPreRec, .38* vs. .73* in SPreRec, and .54* vs. .59* in CPreRec. An ability to evaluate new information based on the old information does not directly affect the L2 reading comprehension but instead affects L2 proficiency itself regardless of the L2Comp measure.

The results from the scores of the post-tests also give an invaluable insight to what kinds of cognitive processes are involved in the change of comprehension over the occurrence of learning and how they take place. Two treatment effects were investigated. Vocabulary knowledge, which addresses textbase construction at a bottom-up processing level, decreased dependence on L2 proficiency in all four

models from the pretest to the posttests; L1MC with L2CompMC (L2 reading comprehension measured by multiple-choice & T/F questions) and L2CompRec (L2 reading comprehension measured by the recall tasks) and L1Rec with L2CompMC and L2CompRec. With the improved VocK, the previously impoverished textbase became enriched, which produced an improved textbase. This enhanced textbase left smaller room for L2 proficiency to play a role, which was shown in the consistently decreased dependence on L2 in all of the four models. Instead, the influence of L1 reading competence, specifically as measured by L1Rec, increased from the pretests to the posttests; from .11 (0.76) to .28 (1.87) in L1Rec with L2CompMC and from .41* (3.13) to .57* (4.27) in L1Rec with L2CompRec. This is consistent with what the CI model for L2 reading would predict; when the textbase, which is a function of L2 proficiency, gets enhanced, the situation model, which is a function of L1 reading competence, would play a bigger role.

In the ScheK condition, different patterns from those of VocK condition were found. The impoverished textbase due to the lack of linguistic knowledge became just slightly enhanced thanks to the inferencing that was driven by the top-down processing or expectation driven process coming from the newly acquired ScheK from the treatment. As a result, the dependence on L2 increased in two models, L1MC with L2CompMC and L1Rec with L2CompMC. This contrasting result with that of the VocK condition affords us some insight to the nature of mental representations created by different types of intervention. The mental representation created by a bottom-processing via vocabulary knowledge is more stable than the

representation created by a top-down processing via schematic knowledge in terms of representing propositions in L2.

The evidence for this argument comes from the change of magnitude in L2CompMC that L2 explains from pretests to posttests. Since the questions are given in English, the task of MC itself requires building one more level of textbase, which could be similar but is still distinguishable from the textbase that readers build from the main text. This second level textbase can be easily built when the mental representation of the main text is scaffolded by vocabulary knowledge or bottom-up processing; in other words, textbase construction scaffolded by intervention that taps into the construct that directly addresses textbase can be transferred to building another textbase, which is not the same as but is similar to the textbase built from the main text. Due to this transferred textbase, the challenge for building the second level textbase has decreased, which brought about the decreased dependence on L2.

Unlike the VocK condition, ScheK is conducive to building the situation model. As mentioned previously, the textbase built from this condition is not stable because the gaps caused by the lack of L2 linguistic knowledge are filled with many inferences made by ScheK which is a top-down processing. Therefore, even though the final mental representation of the text in the ScheK condition may be as good as that in the VocK condition (this was confirmed by the significant improvement in both conditions), the textbase in the ScheK condition is likely to be more impoverished than that of the VocK condition. Due to a less stable or still impoverished textbase although enhanced because of inference making, building another textbase for the questions in MC still leave larger room for L2 proficiency to

play a role. The increased dependence on L2 proficiency was what was observed in the data. As to the role of L1 reading competence in the ScheK condition, there was not much change from the pretest to the posttest; from $-.08$ (-0.48) to $-.12$ (-0.81) in L1MC with L2CompMC and from $-.07$ (-0.47) to $-.05$ (-0.34) in L1Rec with L2CompMC although all of them are not significant, the general trend in change can be noted.

The decreased dependence on L2 in the L1MC with L2CompRec and L1Rec with L2CompRec in the ScheK condition follows the same pattern found in the VocK condition. As explained, what gets taxed in the task of recall is an ability to form macropropositions and use them as a guiding tool for recalling the details. The findings suggest that both types of intervention can make significant differences in L2 reading comprehension, which was confirmed by the significant improvement from the pretests to the posttests. In the task of recall, the cognitive processes involved in each intervention, a bottom-up approach that taxes textbase construction and a top-down approach that taxes situation model construction did not result in the change of the proportions that L1 reading competence and L2 proficiency explain for L2CompRec. The increased magnitude of L1Rec in the posttests in both conditions, which exceeds that of L2 in both the conditions, supports the tenacity of L1Rec effects upon L2CompRec unlike L2 proficiency, which decreased after the acquisition of the VocK. This may inform us valuable insight to pedagogical implications.

The validity of the CI model for L2 reading has been largely confirmed; good fit for the models of PreL2CompMC and the PostL2CompMC in all the indices;

acceptable values for the close fit for the models of PreL2CompRec, PostL2CompRec and PreL2Comp(MC&Rec); and poor fit only for the model of PostL2Comp(MC&Rec). What makes the difference in the model fit in different models needs to be further studied with the nature of what each task taps into in mind.

Chapter 6: Conclusion

6.1. How the findings of the study address the purpose of the study

The present study was motivated by the awareness that there is no comprehensive theory that identifies specific cognitive processes and kinds of knowledge at work for L2 reading comprehension from a global perspective and explains how these cognitive processes and types of knowledge interact to explain L2 reading comprehension in relation to L1 reading competence and L2 proficiency. In order to address this issue, the Construction Integration Model (Kintsch, 1998) was extended to explain L2 reading comprehension. Three representation systems (surface structure, textbase, and situation model) were elaborated in relation to L2 reading comprehension; building a textbase as a function of L2 proficiency and building a situation model as a function of L1 reading competence. Unlike L1 readers who build a textbase automatically and effortlessly, learning L2 readers spend considerable efforts to build a textbase for a given L2 text. The lack of vocabulary knowledge and grammatical knowledge and a less automatized retrieval of existing linguistic knowledge were identified as major sources of problems for building a good textbase for L2 readers. However, it was proposed that L2 readers' competence in their L1 reading comprehension can be used to build a good situation model of a given L2 text because L2 readers can utilize their background knowledge on a given topic, come up with repair strategies when encountered with comprehension breakdown, and make active inferences to make their comprehension coherent. Depending on individual differences in such areas of situation model, a quality and a

quantity of comprehension can vary greatly in L2 reading comprehension as well as L1 reading comprehension.

However, in order for L1 reading competence to be manifested in L2 reading comprehension, the results of the previous research (Carrell, 1991; Bossers, 1991; Bernhardt & Kamil, 1995; Brisbois, 1995) demonstrated that the bottleneck effect of linguistic knowledge (the Linguistic Threshold Hypothesis, Cummins, 1979) needs to be overcome; thus, the better L2 proficiency becomes, the stronger the influence of L1 reading competence. Or in the terms of the CI model, the better textbase L2 readers build, the more important individual differences in building a good situation model become. Even though this finding has greatly enlightened us in understanding L2 reading comprehension, there were no specific cognitive processes identified responsible for explaining this phenomenon.

The first purpose of the study addressed how the CI model (Kintsch, 1998) can be extended to identify specific cognitive processes and types of knowledge involved in this phenomenon in relation to L1 reading competence, L2 proficiency and L2 reading comprehension. The viability of the CI model for L2 reading comprehension was tested using SEM; the scores of L2 reading comprehension, L2 listening comprehension and the vocabulary quiz were used as indicators for a latent construct, textbase (i.e., textbase construction in the case at hand), and the scores of L1 reading comprehension in two measures (multiple-choice and true/false questions and a recall task) and schematic knowledge quiz were used as indicators for a latent construct, situation model construction (i.e., situation model construction in the case at hand).

The measurement model of textbase as a function of L2 proficiency and situation model as a function of L1 reading competence showed good model fit in all three most commonly used fit indices (RMSEA, CFI, and SRMR). When this measurement model was used to explain the scores of different L2 reading comprehension measures of a science text in different conditions, all three model fit indices were good for L2 reading comprehension measured by multiple-choice and true/false questions. Two of the indices (SRMR and CFI) were good for L2 reading comprehension measured by a recall task; even though RMSEA did not indicate a good model fit, the *p* value showed that it was a close fit. When two types of L2 comprehension measures were combined together, CFI showed good fit, RMSEA acceptable fit with *p* value of close fit, and SRMR reaching very close to a good fit (.082 when .08 indicates good model fit). Thus, a general evaluation of the fit indices suggests that the data in this study are suitable for evaluating the CI model for L2 reading comprehension. The relatively small sample size (thirty two) is a limitation, and should be increased in further investigation.

In order to investigate specific cognitive processes and types of knowledge involved in L2 reading comprehension, two kinds of measures and two types of knowledge were tested in the present study. The multiple-choice and true/false questions and a recall task were used to measure reading comprehension competence in both L1 reading and L2 reading. The cognitive process that the multiple-choice and true/false questions involve is proposed to be evaluating propositions given in questions for their truthfulness in relation to the propositions in a main text. This requires L2 readers to build both a textbase and a situation model of a given text but

does not tax L2 readers' memory capacity greatly because L2 readers are allowed to refer back to the main text. Instead, by the way the items were constructed in relation to the texts, the propositions that need to be evaluated tend to be localized at a sentence, several sentences, or paragraphs; thus, micropropositions. However, a recall task requires L2 readers to build good macropropositions that can function as a good anchoring tool of detailed information. Forming good macropropositions is affected by a good situation model rather than a good textbase, which most of the L1 readers build automatically when they are educated adult readers.

Two types of knowledge investigated were vocabulary knowledge and schematic knowledge. Vocabulary knowledge is associated with textbase construction, which is explained by linguistic knowledge, whereas schematic knowledge is associated with situation model construction, which can be moderated largely by background knowledge in the sense that schematic knowledge can lead expectation-driven comprehension. The two types of knowledge were used in a form of intervention in order to see the effect of acquiring each type of knowledge upon L2 reading comprehension in relation to L1 reading competence and L2 proficiency and a textbase and a situation model. Since the vocabulary knowledge helps building a better textbase, the findings showed that the impact of L2 proficiency consistently decreased after the vocabulary knowledge acquisition activity because the enhanced textbase did not leave much room for L2 proficiency to play a role. However, the impact of L1 reading competence increased in the models of L1Rec with L2CompMC and L1Rec with L2CompRec. This result was consistent with the previous findings on the bottleneck effect of linguistic knowledge and the Linguistic Interdependency

Hypothesis (Cummins, 1981) in that the increased L2 proficiency loosened the bottleneck effect of linguistic knowledge, which resulted in the stronger influence of L1 reading competence.

According to the proposed CI model for L2 reading comprehension, the schematic knowledge does not facilitate building a textbase to a great degree but enables L2 readers to fill the gaps caused by poor linguistic knowledge with making inferences, which is guided by schematic knowledge in a top-down processing manner. The consequence of such a process is a mental representation that is characterized with a slightly enhanced textbase but with an enriched situation model. Even though there were several studies that showed the effect of background knowledge or topic familiarity in L2 reading comprehension (Johnson, 1982; Lee, 1986; Barry & Lazarte, 1995; Bugel & Buunk, 1996; Chen & Donin, 1997; Carrell & Wise, 1998; Pulido, 2004), there is no study that addresses how an enhanced background knowledge influences L2 reading comprehension in relation to L2 proficiency in an experimental setting.

The finding of the present study demonstrated that the linguistic threshold effect was not affected to a great degree because the same pattern found in the pretest conditions was observed after the schematic knowledge acquisition; L2 proficiency as the only significant predictor in the models of L1MC with L2CompMC and L1MC with L2CompRec, and L1Rec with L2CompMC, and L1 reading competence and L2 proficiency as significant predictors in the model of L1Rec with L2CompRec. However, the magnitude of influence changed for L2 proficiency and L1 reading competence measured by a recall task. A cognitive process that involves evaluating

localized propositions (or micropropositions) for their truthfulness (multiple-choice and true/false questions) increased the role of L2 proficiency, whereas a cognitive process that asks readers to form macropropositions (recall) decreased the role of L2 proficiency but increased the role of L1 reading competence. The findings about the impact of vocabulary knowledge and schematic knowledge indicate that different levels of representation (textbase and situation model) are indeed two distinct constructs that work differentially in relation to different kinds of knowledge treated, and different kinds of competence (L1 reading competence and L2 proficiency).

One of the most important findings of the study is the path through which L1 reading competence becomes functional in L2 reading comprehension. An ability to form macropropositions was found to be the first route through which L1 reading competence and L2 reading comprehension are connected to each other. The partial confirmation of the Linguistic Threshold Hypothesis (Cummins, 1979) from the pretest data showed that L1Rec with L2CompRec is the only model that has L1 reading competence as a significant predictor in addition to a stronger predictor of L2 proficiency. With the enhanced textbase due to the newly acquired vocabulary knowledge in the vocabulary knowledge acquisition condition, the role of an ability to form macropropositions and use them as an anchoring tool of detailed information for recall in their L1 increased in both measures of L2 reading comprehension (multiple-choice and true/false questions and a recall). In the model of L1Rec with L2CompRec, L1 reading competence became even a stronger predictor than L2 proficiency.

The interpretation of what a recall task involves was elaborated in relation to languages for thinking during the on-line process of L2 reading comprehension. Since forming macropropositions involves synthesizing all the available information from the text and readers' long-term memory resources, it goes without saying that some kind of thinking process gets involved in this phenomenon. Even though research on inner speech in L2 has gained some attention recently (Leontiev, 1981; Cohen, 1998; Guerrero, 2005), there are methodological difficulties due to the nature of inner speech. However, some research that can indirectly address the issue of inner speech or thinking in L2 was elaborated based on the L2 vocabulary acquisition (Jiang, 2000) and L2 sentence processing (Juffs, 2004). One possible method to investigate thinking in L2 is think-aloud protocol. In order to make the protocol data more scientifically interpretable, a text needs to be embedded with vocabulary that has been analyzed based on three stages of lexical development and syntactic structures whose features are already investigated well enough to predict the kinds of constraints L2 readers should deal with. Considering the significance of the issue, a further study needs to be conducted.

6.2 Implications

6.2.1 Theoretical Implications

The foci of the study are to propose a comprehensive theory for L2 reading comprehension and to investigate the effects of two important treatments, vocabulary knowledge and schematic knowledge, each of which addresses theoretically distinct constructs according to the CI model for L2 reading comprehension. The features of

each kind of knowledge in relation to cognitive processing and the consequences of such features for learning have been explored experimentally. Even though what has been found about the two treatment constructs is invaluable, validating a theory for L1 Reading comprehension is of even more worth in the sense that research on L2 reading had been conducted without comprehensive guiding theories, which made it difficult to synthesize a great deal of research conducted in different areas of L2 reading. The proposed theory for L2 reading comprehension identifies several representation systems such as surface structure, a textbase, and a situation model, each of which has distinct functions in both L1 reading comprehension and L2 reading comprehension. Defining L2 proficiency as a function of textbase makes it clear what it means to improve L2 proficiency and how it is related to cognitive abilities of ELLs or L1 reading competence; for example, we can identify the sources of failure in comprehending a text as a failure to build textbase or a failure to build situation model; if it is a textbase, is it a problem of word recognition, retrieval of semantic information, or syntactic processing for word integration?; or if it is a situation model, is it the lack of background knowledge, poor use of monitoring such as detecting coherence or incoherence, or poor ability to form macropropositions?

Fine-grained explorations of the various cognitive processes and materials were conducted; specific features investigated include materials with low-element interactivity and those with high-element interactivity, different processing features such as bottom-up and top-down approaches, and different levels of representation systems such as textbase and situation model. Through what kinds of paths in what strength L1 reading competence and L2 proficiency play a role was also investigated;

how the contribution of L2 proficiency changes over treatments and how L1 reading competence begins to play a role in explaining the variances in L2 reading comprehension (indirect effect of L1MC to L2Comp via L2 and direct effect of L1Rec to L2CompRec, which became a stronger predictor for L2CompRec than L2 in the posttests). How different kinds of treatment (vocabulary knowledge or schematic knowledge) are captured by different kinds of measures for L2 reading has also been interpreted.

The theory and the findings can guide further research more efficiently in the sense that the previous findings not only in L2 reading but also in L1 reading can be incorporated into a global framework for L2 reading comprehension because it identifies important constructs and delineates the paths of such constructs to interact. The theory and the findings also need to inform instruction and assessment as well as research.

6.2.2 Pedagogical Implications

The profiles for ELLs tend to be more diverse than those for monolingual students in the U.S. The presence and the quality of schooling in their home country are influential variables in predicting individual differences in L2 reading comprehension; refugees often do not have good formal education in their previous years, whereas students like the participants in the present study have strong educational background in their L1 despite the lack of authentic interaction in L2 in their everyday life. Differential degrees of automaticity of language greatly affect the choice of language for thinking during L2 reading; the findings of the study suggest that an ability to recall is the path that links L1 reading competence to L2 reading

competence. Improving students' ability to recall involves helping students build background knowledge in various content areas and teaching them how to form effective macropropositions that subsume details of a given text, which requires a high-level thinking skill. When L2 becomes automatized to the level that thinking during L2 reading takes place in L2, what emerges to matter is not linguistic but cognitive and informational aspects of learning.

Due to the dynamic nature of various variables that have their own share of influence at a certain point in ELLs' cognitive and language development (Ellis, 2007), identifying what characteristics of learner competence different instructional activities tap into can facilitate building a repertoire of effective L2 reading instruction. To make reading instruction for ELLs effective, both types of treatment of the present study should be adopted because both of them significantly improved comprehension in the post-tests but had different abilities taxed. L1 reading competence for the acquisition of schematic knowledge and L2 proficiency for the acquisition of vocabulary knowledge. Even though these two are closely intertwined, they are distinct constructs, which benefit different types of learners. For example, learners with good background knowledge and strong cognitive abilities but with relatively low L2 proficiency would benefit more greatly from the vocabulary knowledge acquisition activity, while those with good L2 proficiency but with relatively less L1 background knowledge and less strong cognitive abilities would benefit more from the schematic knowledge acquisition activity. Qualitatively different nature of two important variables, L1 reading competence and L2 proficiency, evidenced by the results of the present study, accounts for the variances

of L2 reading comprehension for different treatment activities. Above all, both of the abilities are the targeted competences that ELLs should develop to become academically successful.

One more pedagogical implication drawn from the findings is not to suppress the use of L1 for L2 reading comprehension when ELLs have already developed conceptual resources in their L1 like those in the present study; the relatively high scores of the quiz on schematic knowledge acquisition activity showed that the participants had already developed some conceptual knowledge on the given topics of the texts used for treatment. Suppressing the use of L1 will cause the delay of conceptual understanding due to the impoverished textbase or too much cognitive load to be processed and will result in impeding the L2 acquisition. That is, the orthography and phonology of words need to be mapped into the clear conceptual information so that relationships among words can be firmly established in L2. The fact that thinking in L1 is an inescapable consequence for ELLs at the formal stage of lexical development needs to be considered for instruction.

In a similar vein, teachers should allow a condition that ELLs can recognize orthography and phonology of an L2 word and simultaneously activate its L1 translation equivalent and its concept (lemma, which includes semantics and syntax) at the second stage of lexical development. The second stage, L1 lemma mediation stage, is not a step that ELLs can skip over if they want to by nature. What needs to be instructionally done is to expedite the transition from the second stage to the third stage, L2 integration stage (the recognition of orthography and phonology directly retrieves its concept without any activation of the L1 translation equivalent). This

transition can be implemented by allowing enough time and opportunities for ELLs to map clearly understood conceptual information into L2 and manipulate it in L2 for authentic communication so that various repertoires of situation model can be stored in their memory in L2. The rich resources for situation model in L2 will place a foundation for thinking in L2 in the end.

One of the benefits of the CI model for L2 reading comprehension from a pedagogical point of view is that it can clarify the differences between the linguistic objectives and content objectives for L2 reading instruction. This is one of the critical issues in instruction for ELLs because teachers of ELLs often become confused in what they address in class, whether it is linguistic or informational. If a goal is teaching academic English to ELLs, teachers must ascertain what they teach when they teach. According to the proposed theory, the linguistic objectives should include every kind of information that is required to build a good textbase, whereas the content objectives should target the enrichment of a situation model. The linguistic knowledge concerns information that is processed at a bottom-up level; vocabulary knowledge and syntactic rules for assigning relationships among words. However, knowledge that concerns content and situation model tends to be conceptual and thus exist in a form of macropropositions in more occasions, even though it includes word level knowledge. Identifying the scope of what teachers of ELLs and content teachers can address is also made possible by the CI framework for L2 reading. In this sense, the proposed theory can make a significant contribution to the pedagogy for ELLs.

6.2.3 Assessment Implications

The assessment implication is also worth noting. Since it is not possible to conceptualize language without contents carried in it, assessment on L2 reading comprehension is always bound to confront the issues of validity; whether it assesses language or contents. The context and the purpose of L2 reading comprehension made clear before the development of assessment is a necessity for any kind of assessment. The process of delineating the context and the purpose of L2 reading assessment needs clear guidelines, which theories should provide. The CI model for L2 reading can define linguistic space (textbase) and informational space (situation model) in relation to the cognitive development of target examinees and the informational scope that can be considered to be familiar or unfamiliar to the target examinees. Depending on various purposes of a specific assessment, accommodations in different areas can be incorporated into tasks with clear theoretical consideration. Without a comprehensive theory, the process of developing assessment and the final product of the process may be less than optimal. With the availability of assessment design framework that incorporates theories into tasks with clear assessment argument structures (EDC, Mislevy, Steinberg, & Almond, 2003; Mislevy & Riconscente, 2006), the CI model for L2 reading comprehension can be put into practice.

6.3 Limitations of the Study

Some of the limitations of the study include the relatively small sample size (32 for treatment groups and 31 for the control group) even though the repeated

design can compensate for this small sample size to a great degree. It is possible that some of the models that have poor fit based on fit indices but have good P values for the test of close fit may have had good model fit if the sample size were larger. One more factor that needs to be mentioned is that the study did not control for background knowledge strictly; it turned out that the topics of photosynthesis and respiration were covered in the previous curriculum of the participants but not the topic of cancer. The topics used for the treatment comparison were learned ones, whereas the topic for the control group was not in the previous curriculum. Since the patterns found in the pretests for all the three topics were similar (i.e., L2 proficiency is the only significant predictor for all L2 comprehension measures except that L1Rec is also a significant predictor for L2CompRec in all three conditions of pretests), it is concluded that students' knowledge of the topic of cancer, not encountered in previous curricula, did not play a significant role.

One caution to be noted is that the results from one experimental study conducted in the present dissertation can never be used to make generalization concerning the theory itself. Even though the theory is proposed to serve as principles to explain universal aspects of L2 reading comprehension, thorough validation of the theory requires numerous studies of replicating the same study, considering sampling of participants with different profiles (different L1s, different age, and different contexts – English as a second language or a foreign language) and considering characteristics of different kinds of texts in different content areas.

6.4 Future Directions

The study also suggests areas and foci for future investigation. Just to list a few, the questions include whether the same findings are to be observed when the present study is replicated in an English as a foreign language (EFL) setting like Korea and in an English as a second language (ESL) setting in the U.S., how the patterns change as L2 proficiency changes, whether different L1 groups (those whose L1s share cognates with English and those whose L1s do not share any, which addresses surface structure of the CI model) would show the same patterns as the findings in the study, how individual differences in grammatical knowledge and its degrees of automatization play a role in building textbase and situation model and thinking in L2, how motivation plays a role in comprehension, how different kinds of strategies are used for good L2 readers as opposed poor L2 readers, and more specifically, how comprehension changes with two treatments and in what order the comprehension can get maximized in relation to the nature of knowledge.

One particular instructional model for reading that is consistent with the principles of the theory is reciprocal teaching proposed by Palincsar and Brown (1984). The four study activities that they proposed, summarizing (self-review), questioning, clarifying, and predicting, facilitate recognizing surface structure, building textbase, and elaborating situation model. Once ELLs are given schematic knowledge (informational scaffolding), the activities of questioning and clarifying about the mental representation that ELLs build can afford them chances to enhance impoverished textbase by discussing with their partners and checking dictionaries for meanings of words in their L1. This will ensure the conceptual understanding of the

texts, which is critical to academic success for ELLs. The activities of summarizing and predicting should be done in L2 because they have already built good textbase by engaging the activities of questioning and clarifying in their L1, which can spare cognitive resources for manipulating L2 linguistic information; dual processing demands have been fixed to be only one dimensional challenge, and this is the place where ELLs can strengthen the links between L2 and concepts and expedite the automatization process of syntactic rules and direct conceptual access. Thus, the activities of questioning and clarifying can address textbase or L2 proficiency, whereas those of summarizing and predicting can address situation model or L1 reading competence. Different kinds of objectives (linguistic and content) can also be incorporated within this pedagogical model. How this framework can effectively be merged within real classroom settings needs to be studied.

Methodologically, the investigation of changes in L2 comprehension needs to be made in a longitudinal study; for example, how the roles of L1 reading competence and L2 proficiency change in L2 reading comprehension over a period of one semester in the ESL and the EFL contexts. The present study explored the relationships among L1 reading competence, L2 proficiency and L2 reading comprehension in an experimental setting unlike the previous studies that investigated the same issue only in a correlational design. The use of structural equation modeling also made it possible to engage with the multidimensional nature of the construct L2 comprehension. These two methodological issues (the use of an experimental study and more sophisticated statistical model to accommodate the multidimensionality of the constructs) need to be addressed in future studies. Study of think-aloud protocols

can elaborate differences between a bottom-up processing and a top-down processing and inform us what kinds of strategies are effectively used in which contexts. One that appears to be most urgent is synthesizing existing literature on L2 reading comprehension in a proposed theory of L2 reading comprehension so that a global perspective can be laid out for further research and instruction.

Appendices

Appendix A: Materials for a vocabulary acquisition activity and a quiz

.....
.....

SECTION 1:

..... list
..... 5 42
.....
.....

SECTION 2:

.....
.....
..... Page
30 42
.....

SECTION 3:

..... Quiz 15
.....

..... : _____
..... : _____

SECTION 1:
. (5 .)

- | | |
|---------------------------|---------------------------|
| 1. absorb: _____ | 21. mask: _____ |
| 2. algae : _____ | 22. occurs : _____ |
| 3. batter : _____ | 23. opening: _____ |
| 4. calculator: _____ | 24. organism: _____ |
| 5. capture: _____ | 25. oxygen : _____ |
| 4. carbohydrate: _____ | 26. photosynthesis: _____ |
| 5. carbon dioxide : _____ | 27. pigments: _____ |
| 6. carry out : _____ | 28. probably : _____ |
| 7. cells : _____ | 29. process : _____ |
| 8. chemical : _____ | 30. product: _____ |
| 9. chlorophyll: _____ | 31. protein: _____ |
| 10. combine : _____ | 32. raw : _____ |
| 11. complex : _____ | 33. reaction: _____ |
| 12. complicated : _____ | 34. root : _____ |
| 13. compound: _____ | 35. soil: _____ |
| 14. contain : _____ | 36. solar : _____ |
| 15. convert : _____ | 37. stage: _____ |
| 16. familiar : _____ | 38. stem : _____ |
| 17. function: _____ | 39. substance: _____ |
| 18. glucose: _____ | 40. supply: _____ |
| 19. ingredients : _____ | 41. transport: _____ |
| 20. involve: _____ | 42. undersides : _____ |

SECTION 2:
Page (30)

1. absorb

If something **absorbs** light, heat, or another form of energy, it takes it in.

A household radiator absorbs energy in the form of electric current and releases it in the form of heat.

.....
.....

2. algae

Algae is a type of plant with no stems or leaves that grows in water or on damp surfaces.

.....
.....

3. batter

Batter is a mixture of flour, eggs, and milk that is used in cooking.

.....

4. calculator

A **calculator** is a small electronic device that you use for making mathematical calculations.

.....
.....

5. capture

To capture is to gain control of or exert influence over something.

A TV show that captured 30% of the prime-time audience was an unexpected result.

..... 30% TV
.....

4. carbohydrate

Carbohydrates are substances, found in certain kinds of food, that provide you with energy. Foods such as sugar and bread that contain these substances can also be referred to as **carbohydrates**.

Food is made up of carbohydrates, proteins and fats.

.....,

5. carbon dioxide

Carbon dioxide is a gas, which is produced by animals and people breathing out.

.....
.....

6. carry out

If you **carry out** a task or instruction, you do it or act according to it.
Commitments to the organization have been made with very little intention of carrying them out.

..... /
.....

7. cells

A **cell** is the smallest part of an animal or plant that is able to function independently.
Every animal or plant is made up of millions of cells.

Soap destroys the cell walls of bacteria.

.....

8. chemical

Chemical means involving or resulting from a reaction between two or more substances, or relating to the substances that something consists of.

chemical reactions that cause ozone destruction.

.....

9. chlorophyll

Chlorophyll is a green substance in plants which enables them to use the energy from sunlight in order to grow.

.....
.....

10. combine

If you **combine** two or more things or if they **combine**, they join together to make a single thing.

Carbon, hydrogen and oxygen combine chemically to form carbohydrates and fats.

..... , ,
.....

11. complex

Something that is **complex** has many different parts, and is therefore often difficult to understand.

Her complex personality made him confused.

.....

12. complicated

If you say that something is **complicated**, you mean it has so many parts or aspects that it is difficult to understand or deal with.

The situation in Lebanon is very complicated.

.....

13. compound

In chemistry, a **compound** is a substance that consists of two or more elements.

Organic compounds contain carbon in their molecules.

.....

14. contain

If a substance **contains** something, that thing is a part of it.

Many cars run on petrol which contains lead.

.....

15. convert

If one thing **is converted** or **converts** into another, it is changed into a different form.

The signal will be converted into digital code.

.....

16. familiar

If you are **familiar with** something, you know or understand it well.

Lesinko is quite familiar with Central Television because he worked there for 25 years.

..... 25 Central TV Central TV

17. function

The **function** of something or someone is the useful thing that they do or are intended to do.

The main function of the commercial banks is to raise capital for industry.

.....

18. glucose

Glucose is a type of sugar that gives you energy.

.....

19. ingredients

Ingredients are the things that are used to make something, especially all the different foods you use when you are cooking a particular dish.

Mix in the all remaining ingredients.

.....

20. involve

If a situation or activity **involves** something, that thing is a necessary part or consequence of it.

Running a kitchen at a big hotel involves a great deal of discipline and speed.

.....

21. mask

If one thing **masks** another, it prevents people from noticing or recognizing the other thing.

A thick grey cloud masked the sun.

.....

22. occurs

When something **occurs**, it happens.

If headaches only occur at night, lack of fresh air and oxygen is often the cause.

.....
.....

23. opening

An **opening** is a hole or empty space through which things or people can pass.

He squeezed through a narrow opening in the fence.

.....

24. organism

An **organism** is an animal or plant, especially one that is so small that you cannot see it without using a microscope.

Not all chemicals normally present in living organisms are harmless.

..... /

25. oxygen

Oxygen is a colorless gas that exists in large quantities in the air. All plants and animals need oxygen in order to live.

The human brain needs to be without oxygen for only four minutes before permanent damage occurs.

..... 4

26. photosynthesis

Photosynthesis is the way that green plants make their food using sunlight.

.....

27. pigments

A **pigment** is a substance that gives something a particular color.

The Romans used natural pigments on their fabrics and walls.

.....

28. probably

If you say that something is **probably** the case, you think that it is likely to be the case, although you are not sure.

The White House probably won't make this plan public until July.

..... 7

29. process

A **process** is a series of things which happen naturally and result in a biological or chemical change.

The regularity of this symptom suggests that the process is genetically determined.

.....

30. product

If you say that someone or something is a **product of** a situation or process, you mean that the situation or process has had a significant effect in making them what they are.

We are all products of our time.

.....

31. protein

Protein is a substance found in food and drink such as meat, eggs, and milk. You need protein in order to grow and be healthy.

Fish was a major source of protein for the working man.

.....

32. raw

Raw materials or substances are in their natural state before being processed or used in manufacturing.

We import raw materials and energy and export mainly industrial products.

.....

33. reaction

A chemical **reaction** is a process in which two substances combine together chemically to form another substance.

Ozone is produced by the reaction between oxygen and ultra-violet light.

.....

34. root

The **root** of a word is the part that contains its meaning and to which other parts can be added.

The word 'secretary' comes from the same Latin root as the word 'secret'.

.....

35. soil

Soil is the substance on the surface of the earth in which plants grow.

We have the most fertile soil in Europe.

.....

36. solar

Solar is used to describe things relating to the sun.

Solar power is obtained from the sun's light and heat.

.....

37. stage

A **stage** of an activity, process, or period is one part of it.

The way children talk about or express their feelings depends on their age and stage of development.

.....
.....

38. stem

The **stem** of a plant is the thin, upright part on which the flowers and leaves grow.

He stooped down and cut the stem of the flower with his knife and handed her the flower.

.....
.....

39. substance

A **substance** is a solid, powder, liquid, or gas with particular properties.

There's absolutely no regulation of cigarettes to make sure that they don't include poisonous substances.

.....
.....

40. supply

If you **supply** someone with something that they want or need, you give them a quantity of it.

An agreement not to produce or supply chemical weapons has been made by the two countries.

.....
.....

41. transport

To **transport** people or goods somewhere is to take them from one place to another in a vehicle.

The troops were transported to Moscow.

.....

42. undersides

The **underside** of something is the part of it which normally faces towards the ground.

The underside of the car cannot be washed manually.

.....

- 26. photosynthesis:
.....
- 27. pigments:
.....
- 28. probably : 7
- 29. process :
.....
- 30. product:
.....
- 31. protein:
.....
- 32. raw :
.....
- 33. reaction:
.....
- 34. root : ‘’
- 35. soil:
.....
- 36. solar :
.....
- 37. stage:
.....
- 38. stem :
.....
- 39. substance:
.....
- 40. supply:
.....
- 41. transport:
.....
- 42. undersides :
.....

SECTION 3: QUIZ

..... Quiz
..... 15

1. absorb: _____
A household radiator absorbs energy in the form of electric current and releases it in the form of heat.

2. algae : _____
Algae is a type of plant with no stems or leaves that grows in water or on damp surfaces.

3. batter : _____
Batter is a mixture of flour, eggs, and milk that is used in cooking.

4. calculator: _____
A calculator is a small electronic device that you use for making mathematical calculations.

5. capture: _____
A TV show that captured 30% of the prime-time audience was an unexpected result.

4. carbohydrate: _____
Food is made up of carbohydrates, proteins and fats.

5. carbon dioxide : _____
Carbon dioxide is a gas, which is produced by animals and people breathing out.

6. carry out : _____
Commitments to the organization have been made with very little intention of carrying them out.

7. cells : _____
Soap destroys the cell walls of bacteria.

8. chemical : _____
chemical reactions that cause ozone destruction.

9. chlorophyll: _____
Chlorophyll is a green substance in plants which enables them to use the energy from sunlight in order to grow.

10. combine : _____
Carbon, hydrogen and oxygen combine chemically to form carbohydrates and fats.

11. complex : _____

Her complex personality made him confused.

12. complicated : _____

The situation in Lebanon is very complicated.

13. compound : _____

Organic compounds contain carbon in their molecules.

14. contain : _____

Many cars run on petrol which contains lead.

15. convert : _____

The signal will be converted into digital code.

16. familiar : _____

Lesinko is quite familiar with Central Television because he worked there for 25 years.

17. function: _____

The main function of the commercial banks is to raise capital for industry.

18. glucose: _____

Glucose is a type of sugar that gives you energy.

19. ingredients : _____

Mix in the all remaining ingredients.

20. involve: _____

Running a kitchen at a big hotel involves a great deal of discipline and speed.

21. mask: _____

A thick grey cloud masked the sun.

22. occurs : _____

If headaches only occur at night, lack of fresh air and oxygen is often the cause.

23. opening: _____

He squeezed through a narrow opening in the fence.

24. organism: _____

Not all chemicals normally present in living organisms are harmless.

25. oxygen : _____

The human brain needs to be without oxygen for only four minutes before permanent damage occurs.

26. photosynthesis: _____
Photosynthesis is the way that green plants make their food using sunlight.
27. pigments: _____
The Romans used natural pigments on their fabrics and walls.
28. probably : _____
The White House probably won't make this plan public until July.
29. process : _____
The regularity of this symptom suggests that the process is genetically determined.
30. product: _____
We are all products of our time.
31. protein: _____
Fish was a major source of protein for the working man.
32. raw : _____
We import raw materials and energy and export mainly industrial products.
33. reaction: _____
Ozone is produced by the reaction between oxygen and ultra-violet light.
34. root : _____
The word `secretary' comes from the same Latin root as the word `secret'.
35. soil: _____
We have the most fertile soil in Europe.
36. solar : _____
Solar power is obtained from the sun's light and heat.
37. stage: _____
The way children talk about or express their feelings depends on their age and stage of development.
38. stem : _____
He stooped down and cut the stem of the flower with his knife and handed her the flower.
39. substance: _____
There's absolutely no regulation of cigarettes to make sure that they don't include poisonous substances.

40. supply: _____

An agreement not to produce or supply chemical weapons has been made by the two countries.

41. transport: _____

The troops were transported to Moscow.

42. undersides : _____

The underside of the car cannot be washed manually.

Appendix B: Materials for a schematic knowledge acquisition activity and a quiz

.....
..... Section

SECTION 1:

..... graphic Concept Map
.....
..... Page Page
..... Concept Map 10 ,
Page , 10
..... Page Concept Map
..... 10
..... , page

SECTION 2:

..... Concept Map
..... 5

SECTION 3:

..... Concept Map Quiz Concept
Map (10).
..... (5).

..... : _____
..... : _____

- **Concept Map**
 graphic
 **Concept Map**
 **task** (10)

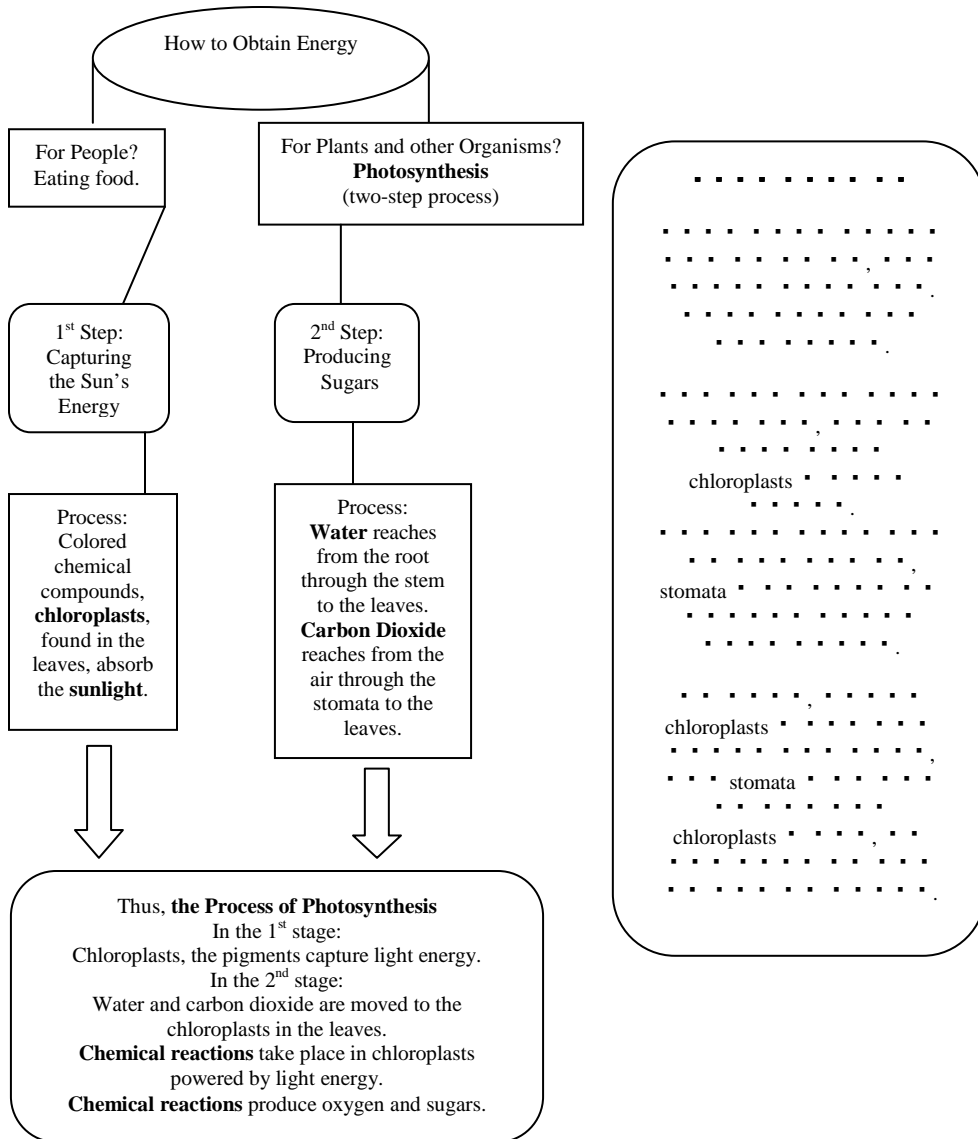

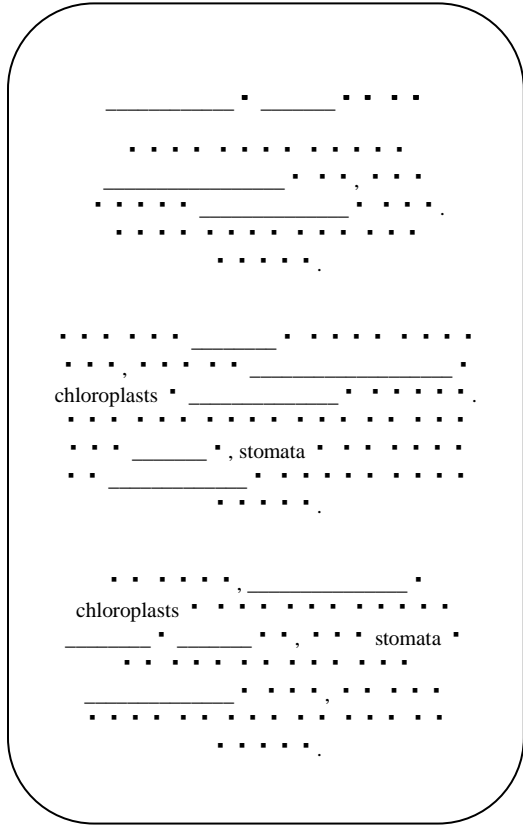
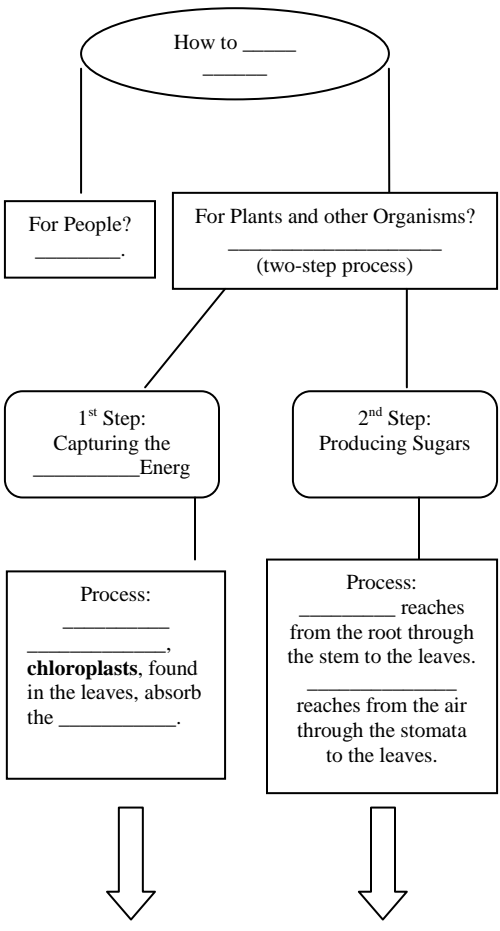

Thus, the Process of Photosynthesis
 In the 1st stage:
 Chloroplasts, the _____ capture light energy.
 In the 2nd stage:
 Water and carbon dioxide are moved to the _____ in the leaves.
Chemical reactions take place in chloroplasts _____ by light energy.
Chemical reactions produce oxygen and sugars.

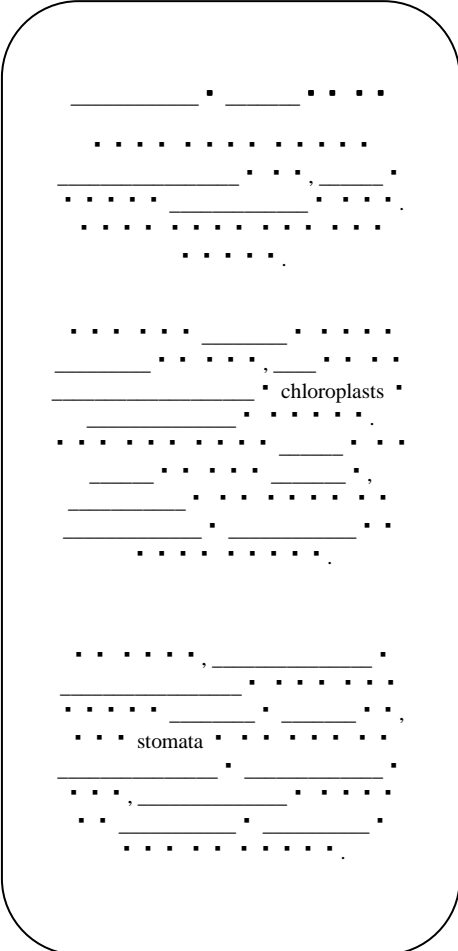
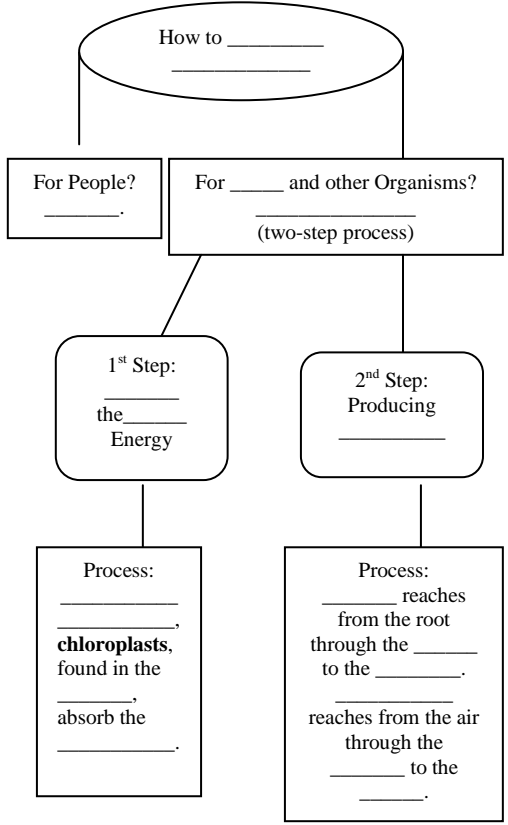

Thus, the Process of Photosynthesis

In the 1st stage:
 _____, the _____ capture
 light energy.

In the 2nd stage:
 Water and _____ are moved to the
 _____ in the leaves.
 _____ take place in
 _____ by
 light energy.
Chemical reactions produce _____ and
 _____.

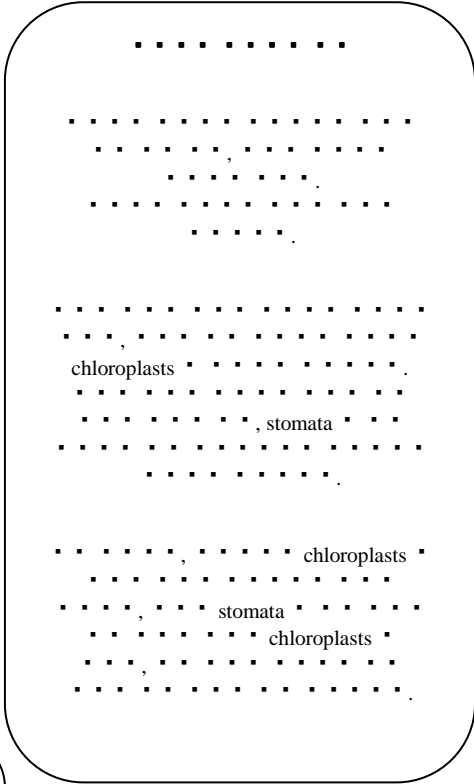
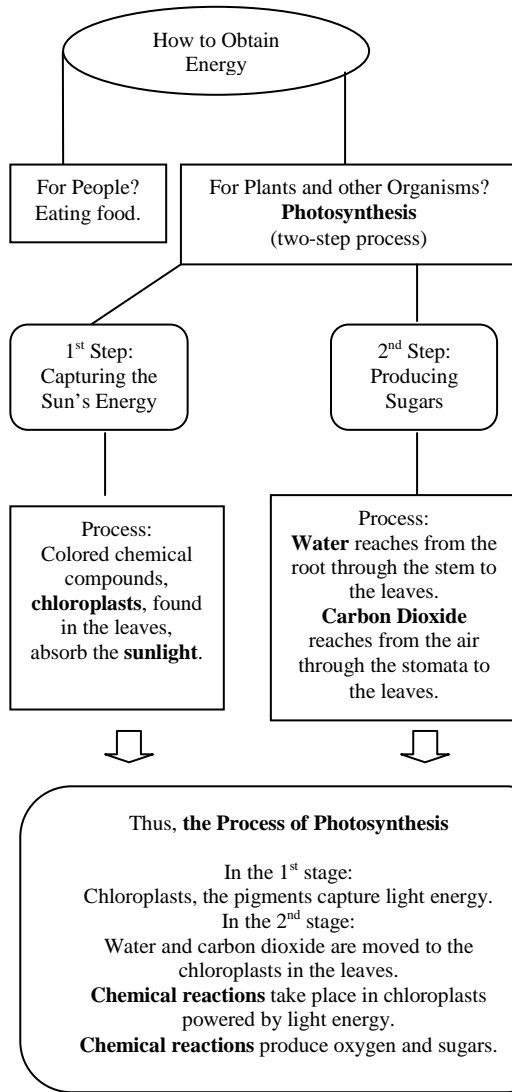

Quiz on the Concept Map (10 □)

□ □ : _____

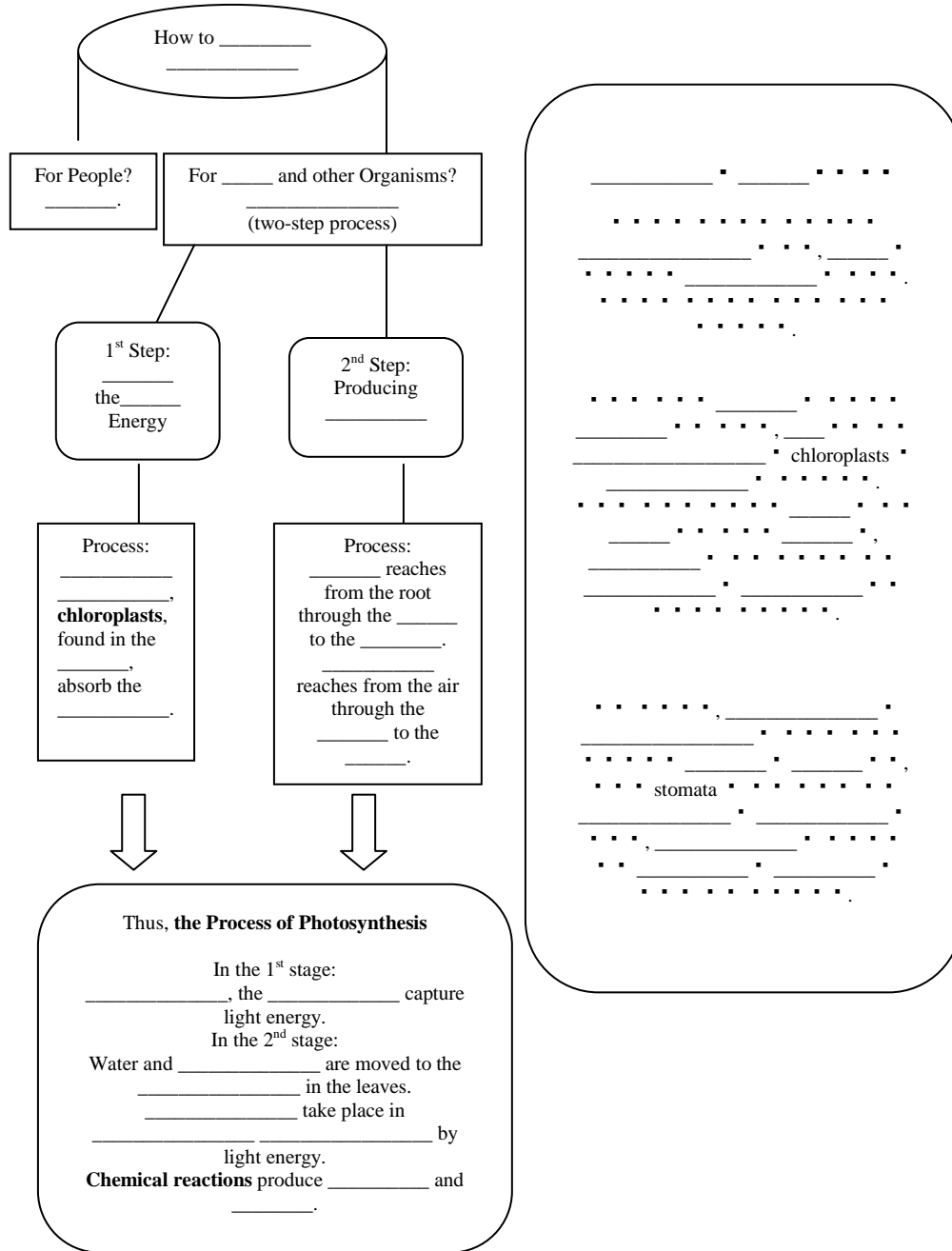

Thus, the Process of Photosynthesis

In the 1st stage:
 _____, the _____ capture
 light energy.
 In the 2nd stage:
 Water and _____ are moved to the
 _____ in the leaves.
 _____ take place in
 _____ by
 light energy.
Chemical reactions produce _____ and
 _____.

Appendix C: Materials for a pretest (photosynthesis)

PRE-TEST

.....!

.....:

.....: _____

.....: _____

..... 50

1. (5) - (5)
2. (5) - (5)
3. (5) - (5)
4. (20)

1.1. (5).

Every living thing needs energy. All cells need energy to carry out their functions such as making proteins and transporting substances into and out of the cell. Your picnic lunch supplies your cells with the energy they need. But plants and other organisms, such as algae and some bacteria, obtain their energy in a different way. These organisms use the energy in sunlight to make their own food.

The process by which a cell captures the energy in sunlight and uses it to make food is called photosynthesis. The term *photosynthesis* comes from the root words, *photo*, which means “light,” and *synthesis*, which means “putting together.” Photosynthesis means

Photosynthesis is a very complicated process. During photosynthesis, plants and some other organisms use energy from the sun to convert carbon dioxide and water into oxygen and sugars, including glucose. You can think of photosynthesis as taking place in two stages: capturing the sun’s energy and producing sugars. You’re probably familiar with many two-stage processes. To make a cake, for example, the first stage is to combine the ingredients to make the batter. The second stage is to bake the batter in an oven. To get the desired result – the cake – both stages must occur in the correct order.

Capturing the sun’s energy: the first stage of photosynthesis involves capturing the energy in sunlight. In plants, this energy-capturing process occurs in the leaves and other green parts of the plant. In most plants, leaf cells contain more chloroplasts than do cells in other parts of the plant.

The chloroplasts in plant cells give plants their green color. The green color comes from pigments, colored chemical compounds that absorb light. The main pigment found in the chloroplast of plants is chlorophyll. Chloroplasts may also contain yellow and orange pigments, but they are usually masked by the green color of chlorophyll.

Chlorophyll and the other pigments function in a manner similar to that of the solar “cells” in a solar-powered calculator. Solar cells capture the energy in light and use it to power the calculator. Similarly, the pigments capture light energy and use it to power the second stage of photosynthesis.

Using energy to make food: in the second stage of photosynthesis, the cell uses the captured energy to produce sugars. The cell needs two raw materials for this stage: water (H₂O) and carbon dioxide (CO₂). In plants, the roots absorb water from the soil. The water then moves up through the plant’s stem to the leaves. Carbon dioxide is one of the gases in the air. Carbon dioxide enters the plant through small openings on the undersides of the leaves called stomata. Once in the leaves, the water and carbon dioxide move into the chloroplasts.

Inside the chloroplasts, the water and carbon dioxide undergo a complex series of chemical reactions. The reactions are powered by the energy captured in the first stage. One of the products of the reactions is oxygen (O₂). The other products are sugars, including glucose; sugars are a type of carbohydrate. Cells can use the energy in the sugars to carry out important cell functions.

1.2. ,
. (5).

2.1. ■ ■ ■ ■ : ■ ■ ■ ■ ■ ■ ■ ■ ‘ ■ ■ ■ ■ ■ ■ ’ ■ ■ ■ ■ ■ ■ ■ ■ ■ ■
■ ■ ■ ■ ■ ■ ■ ■ ■ ■ ■ ■ ■ ■ (5 ■).

Every living thing needs energy. All cells need energy to carry out their functions such as making proteins and transporting substances into and out of the cell. Your picnic lunch supplies your cells with the energy they need. But plants and other organisms, such as algae and some bacteria, obtain their energy in a different way. These organisms use the energy in sunlight to make their own food.

The process by which a cell captures the energy in sunlight and uses it to make food is called photosynthesis. The term *photosynthesis* comes from the root words, *photo*, which means “light,” and *synthesis*, which means “putting together.” Photosynthesis means _____.

Photosynthesis is a very complicated process. During photosynthesis, plants and some other organisms use energy from the sun to convert carbon dioxide and water into oxygen and sugars, including glucose. You can think of photosynthesis as taking place in two stages: capturing the sun’s energy and producing sugars. You’re probably familiar with many two-stage processes. To make a cake, for examples, the first stage is to combine the ingredients to make the batter. The second stage is to bake the batter in an oven. To get the desired result – the cake – both stages must occur in the correct order.

2.2. \dots ,
 \dots (5 \dots).

2.3. ■ ■ ■ ■ : ■ ■ ■ ■ ■ ■ ■ ■ ‘ ■ ■ ■ ■ ■ ■ ’ ■ ■ ■ ■ ■ ■ ■ ■ ■ ■
■ ■ ■ ■ ■ ■ ■ ■ ■ ■ ■ ■ ■ ■ (5 ■).

Capturing the sun’s energy: the first stage of photosynthesis involves capturing the energy in sunlight. In plants, this energy-capturing process occurs in the leaves and other green parts of the plant. In most plants, leaf cells contain more chloroplasts than do cells in other parts of the plant.

The chloroplasts in plant cells give plants their green color. The green color comes from pigments, colored chemical compounds that absorb light. The main pigment found in the chloroplast of plants is chlorophyll. Chloroplasts may also contain yellow and orange pigments, but they are usually masked by the green color of chlorophyll.

Chlorophyll and the other pigments function in a manner similar to that of the solar “cells” in a solar-powered calculator. Solar cells capture the energy in light and use it to power the calculator. Similarly, the pigments capture light energy and use it to power the second stage of photosynthesis.

Using energy to make food: in the second stage of photosynthesis, the cell uses the captured energy to produce sugars. The cell needs two raw materials for this stage: water (H₂O) and carbon dioxide (CO₂). In plants, the roots absorb water from the soil. The water then moves up through the plant’s stem to the leaves. Carbon dioxide is one of the gases in the air. Carbon dioxide enters the plant through small openings on the undersides of the leaves called stomata. Once in the leaves, the water and carbon dioxide move into the chloroplasts.

Inside the chloroplasts, the water and carbon dioxide undergo a complex series of chemical reactions. The reactions are powered by the energy captured in the first stage. One of the products of the reactions is oxygen (O₂). The other products are sugars, including glucose; sugars are a type of carbohydrate. Cells can use the energy in the sugars to carry out important cell functions.

2.4. \dots ,
 \dots (5 \dots).

3. page .
. (20 .).

1. Making proteins is one of the ways how cells use energy. True / False
2. Every living thing uses the same mechanisms to gain energy for their living. True / False
3. Algae cannot make their own food. True / False
4. The source of energy for photosynthesis is the sun. True / False
5. The energy obtained from the sun is used to change oxygen and sugar into carbon dioxide. True / False
6. The two-step process for photosynthesis involves capturing light energy and producing water. True / False
7. Baking a cake explains the fact that two steps for photosynthesis should take place in the correct order. True / False
8. The leaves are the only part through which plants obtain their energy from sunlight. True / False
9. Chlorophyll, the main pigment found in the leaf cells is always green. True / False
10. The more chloroplasts are found in the leaf cells, the more light gets absorbed in the plants. True / False
11. Water that is absorbed through stomata is moved into the chloroplasts. True / False
12. Stomata are found only in one side of leaves. True / False
13. Carbohydrates and oxygen are two raw materials for photosynthesis. True / False
14. The light energy is necessary for the chemical reaction to occur. True / False
15. All organisms that carry out photosynthesis release oxygen. True / False

<Qs16~18>

16. What does “it” refer to?

The process by which a cell captures the energy in sunlight and uses it to make food is called photosynthesis.

- ① process ② a cell ③ the energy ④ food

17. Which of the following fits the blank best?

The term *photosynthesis* comes from the root words, *photo*, which means “light,” and *synthesis*, which means “putting together.” Photosynthesis means _____.

- ① making energy for light ② using light to make food
③ putting photos together ④ transporting food through light

18. Which of the following is not directly related to the second stage of photosynthesis?

- ① water ② carbon dioxide ③ sugar ④ light

Every living thing needs energy. All cells need energy to carry out their functions such as making proteins and transporting substances into and out of the cell. Your picnic lunch supplies your cells with the energy they need. But plants and other organisms, such as algae and some bacteria, obtain their energy in a different way. These organisms use the energy in sunlight to make their own food.

The process by which a cell captures the energy in sunlight and uses it to make food is called photosynthesis. The term *photosynthesis* comes from the root words, *photo*, which means “light,” and *synthesis*, which means “putting together.” Photosynthesis means _____.

Photosynthesis is a very complicated process. During photosynthesis, plants and some other organisms use energy from the sun to convert carbon dioxide and water into oxygen and sugars, including glucose. You can think of photosynthesis as taking place in two stages: capturing the sun’s energy and producing sugars. You’re probably familiar with many two-stage processes. To make a cake, for examples, the first stage is to combine the ingredients to make the batter. The second stage is to bake the batter in an oven. To get the desired result – the cake – both stages must occur in the correct order.

Capturing the sun’s energy: the first stage of photosynthesis involves capturing the energy in sunlight. In plants, this energy-capturing process occurs in the leaves and other green parts of the plant. In most plants, leaf cells contain more chloroplasts than do cells in other parts of the plant.

The chloroplasts in plant cells give plants their green color. The green color comes from pigments, colored chemical compounds that absorb light. The main pigment found in the chloroplast of plants is chlorophyll. Chloroplasts may also contain yellow and orange pigments, but they are usually masked by the green color of chlorophyll.

Chlorophyll and the other pigments function in a manner similar to that of the solar “cells” in a solar-powered calculator. Solar cells capture the energy in light and use it to power the calculator. Similarly, the pigments capture light energy and use it to power the second stage of photosynthesis.

Using energy to make food: in the second stage of photosynthesis, the cell uses the captured energy to produce sugars. The cell needs two raw materials for this stage: water (H₂O) and carbon dioxide (CO₂). In plants, the roots absorb water from the soil. The water then moves up through the plant’s stem to the leaves. Carbon dioxide is one of the gases in the air. Carbon dioxide enters the plant through small openings on the undersides of the leaves called stomata. Once in the leaves, the water and carbon dioxide move into the chloroplasts.

Inside the chloroplasts, the water and carbon dioxide undergo a complex series of chemical reactions. The reactions are powered by the energy captured in the first stage. One of the products of the reactions is oxygen (O₂). The other products are sugars, including glucose; sugars are a type of carbohydrate. Cells can use the energy in the sugars to carry out important cell functions.

Appendix D: Proposition analysis of photosynthesis, respiration, cancer and blood circulation and lymph

Proposition analysis of Photosynthesis

Original Text	Propositions extracted in each paragraph
<p>Every living thing needs energy. All cells need energy to carry out their functions such as making proteins and transporting substances into and out of the cell. Your picnic lunch supplies your cells with the energy they need. But plants and other organisms, such as algae and some bacteria, obtain their energy in a different way. These organisms use the energy in sunlight to make their own food.</p>	<ol style="list-style-type: none"> 1) Every living thing needs energy. 2) All cells need energy. 3) <i>All cells</i> carry out their functions 4) <i>Their functions include</i> making proteins and 5) <i>Their functions include</i> transporting substance into and out of the cell. 6) Your picnic lunch supplies your cells with the energy. 7) Your cells need energy. 8) Plants and other organisms obtain their energy in a different way. 9) <i>Such plants and organisms include</i> algae and some bacteria. 10) These organisms use the energy in sunlight. 11) These organisms make their own food.
<p>The process by which a cell captures the energy in sunlight and uses it to make food is called photosynthesis. The term <i>photosynthesis</i> comes from the root words, <i>photo</i>, which means “light,” and <i>synthesis</i>, which means “putting together.” Photosynthesis means using light to make food.</p>	<ol style="list-style-type: none"> 12) A cell captures the energy in sunlight. 13) A cell uses the energy to make food 14) Such a process is called photosynthesis. 15) The term photosynthesis comes from the root words, photo, and synthesis. 16) Photo <i>means</i> light 17) Synthesis <i>means</i> putting together. 18) Photosynthesis means using light to make food.
<p>Photosynthesis is a very complicated process. During photosynthesis, plants and some other organisms use energy from the sun to convert carbon dioxide and water into oxygen and sugars, including glucose. You can think of photosynthesis as taking place in two stages: capturing the sun’s energy and producing sugars. You’re probably familiar with many two-stage processes. To make a cake, for examples, the first stage is to combine the ingredients to make the batter. The second stage is to bake the batter in an oven. To get the desired result – the cake – both stages must occur in the correct order.</p>	<ol style="list-style-type: none"> 19) Photosynthesis is a very complicated process. 20) During photosynthesis, plants and some other organisms use energy from the sun. 21) Plants and some other organisms convert carbon dioxide and water into oxygen and sugars, 22) Sugars include glucose. 23) You can think of photosynthesis as taking place in two stages. 24) These two stages are capturing the sun’s energy and producing sugars. 25) You’re probably familiar with many two-stage processes. 26) To make a cake, the first stage is to combine the ingredients. 27) <i>To make a cake</i>, the first stage is to make the batter.

	<p>28) The second stage is to bake the batter in an oven.</p> <p>29) The desired result is the cake.</p> <p>30) To get the desired result, both stages must occur in the correct order.</p>
<p>Capturing the sun’s energy: the first stage of photosynthesis involves capturing the energy in sunlight. In plants, this energy-capturing process occurs in the leaves and other green parts of the plant. In most plants, leaf cells contain more chloroplasts than do cells in other parts of the plant.</p>	<p>31) Capturing the sun’s energy</p> <p>32) The first stage of photosynthesis involves capturing the energy in sunlight.</p> <p>33) In plants, this energy-capturing process occurs in the leaves</p> <p>34) <i>This energy-capturing process occurs in other green parts of the plant.</i></p> <p>35) In most plants, leaf cells contain more chloroplasts.</p> <p>36) Cells in other parts of the plant contain chloroplasts.</p>
<p>The chloroplasts in plant cells give plants their green color. The green color comes from pigments, colored chemical compounds that absorb light. The main pigment found in the chloroplast of plants is chlorophyll. Chloroplasts may also contain yellow and orange pigments, but they are usually masked by the green color of chlorophyll.</p>	<p>37) <i>The chloroplasts are</i> in plant cells.</p> <p>38) The chloroplasts give plants their green color.</p> <p>39) The green color comes from pigments,</p> <p>40) Pigments are colored chemical compounds.</p> <p>41) The compounds absorb light.</p> <p>42) The main pigment is found in the chloroplast of plants.</p> <p>43) The main pigment is chlorophyll.</p> <p>44) Chloroplasts may also contain yellow and orange pigment.</p> <p>45) But Yellow and orange pigments are usually masked by the green color of chlorophyll.</p>
<p>Chlorophyll and the other pigments function in a manner similar to that of the solar “cells” in a solar-powered calculator. Solar cells capture the energy in light and use it to power the calculator. Similarly, the pigments capture light energy and use it to power the second stage of photosynthesis.</p>	<p>46) Chlorophyll and the other pigments function in a manner similar to that of the solar “cells” in a solar-powered calculator.</p> <p>47) Solar cells capture the energy in light.</p> <p>48) <i>Solar cells</i> use the energy in light</p> <p>49) <i>The energy in light</i> powers the calculator.</p> <p>50) The pigments capture light energy.</p> <p>51) <i>The pigments</i> use the light energy</p> <p>52) <i>The light energy</i> powers the second stage of photosynthesis.</p>
<p>Using energy to make food: in the second stage of photosynthesis, the cell uses the captured energy to produce sugars. The cell needs two raw materials for this stage: water (H₂O) and carbon dioxide (CO₂). In plants, the roots absorb water from the soil. The water then moves up through the plant’s stem to the leaves. Carbon dioxide is one of the gases in the air. Carbon dioxide enters the plant through small openings on the undersides of the leaves called</p>	<p>53) Using energy to make food</p> <p>54) In the second stage of photosynthesis, the cell uses the captured energy.</p> <p>55) <i>The captured cell</i> produces sugars.</p> <p>56) The cell needs two raw materials for this stage.</p> <p>57) <i>Two raw materials are</i> water and carbon dioxide.</p> <p>58) In plants, the roots absorb water.</p> <p>59) <i>The water is</i> from the soil.</p> <p>60) The water then moves up through the plant’s</p>

<p>stomata. Once in the leaves, the water and carbon dioxide move into the chloroplasts.</p>	<p>stem 61) <i>The water then moves up through the plant's stem</i> to the leaves. 62) Gases are in the air. 63) Carbon dioxide is one of <i>the gases</i>. 64) Carbon dioxide enters the plant 65) <i>Carbon dioxide enters the plant</i> through small openings. 66) <i>Small openings are</i> on the undersides of the leaves. 67) Small opening <i>are</i> called stomata. 68) Once carbon dioxide <i>is available</i> in the leaves. 69) The water and carbon dioxide move into the chloroplasts.</p>
<p>Inside the chloroplasts, the water and carbon dioxide undergo a complex series of chemical reactions. The reactions are powered by the energy captured in the first stage. One of the products of the reactions is oxygen (O₂). The other products are sugars, including glucose; sugars are a type of carbohydrate. Cells can use the energy in the sugars to carry out important cell functions.</p>	<p>70) The water and carbon dioxide undergo a complex series of chemical reactions. 71) <i>These chemical reactions take place</i> inside the chloroplasts. 72) The reactions are powered by the energy. 73) The energy was captured in the first stage. 74) One of the products of the reactions is oxygen. 75) The other products are sugars. 76) <i>Sugars</i> include glucose. 77) Sugars are a type of carbohydrate. 78) Cells can use the energy 79) <i>The energy is</i> in the sugars. 80) The energy in the sugars carries out important cell functions.</p>

Proposition Analysis of Respiration

Original Text	Propositions extracted in each paragraph
<p>Everyone knows that food provides energy. But not everyone knows how food provides energy.</p> <p>The food you eat does not provide your body with energy immediately after you eat it. First, the food must pass through your digestive system.</p> <p>There, the food is broken down into small molecules.</p> <p>These small molecules can then pass out of the digestive system and into your bloodstream. Next, the molecules travel through the bloodstream to the cells of your body. Inside the cells, the energy in the molecules is released.</p>	<ol style="list-style-type: none"> 1) Everyone knows that food provides energy. 2) But not everyone knows how food provides energy. 3) You eat the food. 4) The food does not provide your body with energy. 5) <i>immediately after you eat it</i> 6) First, the food must pass through your digestive system. 7) There, the food is broken down into small molecules. 8) These small molecules can then pass out of the digestive system and into your bloodstream. 9) These small molecules can then pass into your blood stream 10) Next, the molecules travel through the bloodstream to the cells of your body. 11) The molecules travel to the cells of your body. 12) The energy is in the molecules <i>inside the cells</i>. 13) The energy is released. 14) <i>This takes places</i> inside the cells.
<p>To understand how cells use energy, think about how people save money in a bank. You might, for example, put some money in a savings account.</p> <p>Then, when you want to buy something, you withdraw some of the money.</p> <p>Cells store and use energy in a similar way. When the cells need energy, they “withdraw” it by breaking down the carbohydrates. This process releases energy.</p> <p>Similarly, when you eat a meal, you add to your body’s energy savings account. When your cells need energy, they make a withdrawal and break down the food to release energy.</p>	<ol style="list-style-type: none"> 15) <i>You need</i> to understand how cells use energy. 16) <i>You should</i> think about how people save money in a bank. 17) You might, for example, put some money in a savings account. 18) You want to buy something. 19) You withdraw some of the money. 20) Cells store in a similar way. 21) Cells use energy in a similar way. 22) When the cells need energy, 23) The cells “withdraw” energy. 24) <i>The cells</i> break down the carbohydrate. 25) This process releases energy. 26) When you eat a meal, 27) You add to your body’s energy savings account. 28) Your eating a meal is similar to adding to your body’s energy savings account. 29) You eat a meal. 30) You add to your body’s energy savings account. 31) When your cells need energy, 32) Your cells make a withdrawal.

	<p>33) Your cells break down the food</p> <p>34) Your cells release energy.</p>
<p>After you eat a meal, your body converts the carbohydrates in the food into glucose a type of sugar.</p> <p>The process by which cells “withdraw” energy from glucose is called respiration.</p> <p>During respiration, cells break down simple food molecules such as glucose and release the energy they contain.</p> <p>Because living things need a continuous supply of energy, the cells of all living things carry out respiration continuously.</p>	<p>35) After you eat a meal,</p> <p>36) Your body converts the carbohydrates into glucose.</p> <p>37) The carbohydrates are in the food.</p> <p>38) Glucose is a type of sugar.</p> <p>39) Cells “withdraw” energy from glucose.</p> <p>40) The process is called respiration.</p> <p>41) During respiration, cells break down simple food molecules.</p> <p>42) Glucose is simple food molecules.</p> <p>43) Cells release the energy.</p> <p>44) The simple food molecules contain energy.</p> <p>45) Living things need a continuous supply of energy.</p> <p>46) Because the cells of all living things carry out respiration continuously.</p>
<p>The term respiration might be confusing. You have probably used it to mean breathing; that is, moving air in and out of your lungs. Because of this confusion, the respiration process that takes place inside cells is sometimes called cellular respiration.</p>	<p>47) The term respiration might be confusing.</p> <p>48) You have probably used the term respiration to mean breathing</p> <p>49) <i>You</i> move air in and out of your lungs.</p> <p>50) There is confusion <i>in the meanings of the term</i>.</p> <p>51) Because the respiration process takes place inside cells.</p> <p>52) The respiration process is sometimes called cellular respiration.</p>
<p>The double use of the term respiration does point out a connection that you should keep in mind.</p> <p>Breathing brings oxygen into your lungs and oxygen is necessary for cellular respiration to occur in most cells.</p> <p>Some cells can obtain energy from glucose without using oxygen.</p> <p>But the most efficient means of obtaining energy from glucose requires the presence of oxygen.</p>	<p>53) The double use of the term respiration does point out a connection</p> <p>54) You should keep the connection in mind.</p> <p>55) Breathing brings oxygen into your lungs</p> <p>56) Oxygen is necessary.</p> <p>57) Cellular respiration occurs in most cells.</p> <p>58) Some cells can obtain energy without using oxygen.</p> <p>59) But you obtain energy from glucose.</p> <p>60) The most efficient means of obtaining energy requires the presence of oxygen.</p>
<p>The Two Stages of Respiration: Respiration is a two-stage process. The first stage takes place in the cytoplasm of the organism’s cells. There, glucose molecules are broken down into smaller molecules. Oxygen is not involved in this stage of respiration. Only a small amount of the energy in glucose is released during this stage.</p>	<p>61) The Two Stages of Respiration: 62) Respiration is a two-stage process. 63) The first stage takes place in the cytoplasm. 64) The organism’s cells have the cytoplasm. 65) Glucose molecules are broken down into smaller molecules in the cytoplasm. 66) Oxygen is not involved in this stage of respiration. 67) Only a small amount of the energy in glucose is released during this stage.</p>
<p>The second stage of respiration takes place in</p>	<p>68) The second stage of respiration takes place</p>

<p>the mitochondria. There, the small molecules are broken down into even smaller molecules. These chemical reactions require oxygen, and a great deal of energy is released. This is why the mitochondria are sometimes called the “powerhouses” of the cell.</p>	<p>in the mitochondria. 69) The small molecules are broken down into even smaller molecules in the mitochondria. 70) These chemical reactions require oxygen 71) A great deal of energy is released. 72) The mitochondria are sometimes called powerhouses of the cells. 73) This is why.</p>
<p>If you trace the steps in the breakdown of glucose, you’ll see that energy is released in both stages. Two other products of respiration are carbon dioxide and water. These products diffuse out of the cell. In animals, the carbon dioxide and some water leave the body when they breathe out. Thus, when you breathe in, you take in oxygen, a raw material for respiration. When you breathe out, you release carbon dioxide and water, products of respiration.</p>	<p>74) If you trace the steps in the breakdown of glucose. 75) You’ll see that 76) Energy is released in both stages. 77) There are two other products of respiration. 78) They are carbon dioxide and water. 79) Carbon dioxide and water diffuse out of the cell. 80) In animals, the carbon dioxide and some water leave the body 81) When animals breathe out. 82) Thus, when you breathe in, you take in oxygen, a raw material for respiration. Thus, 83) When you breathe in 84) You take in oxygen 85) Oxygen is a raw material for respiration. 86) When you breathe out, you release carbon dioxide and water, products of respiration. 87) When you breathe out. 88) You release carbon dioxide and water. 89) Carbon dioxide and water are products of respiration</p>











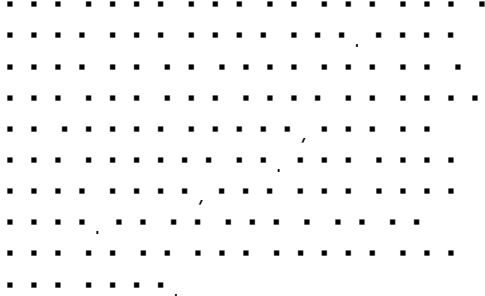

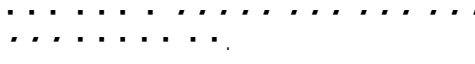



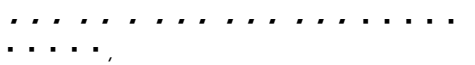

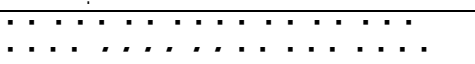

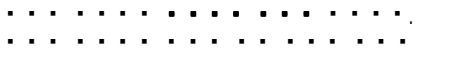
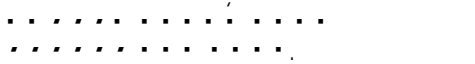
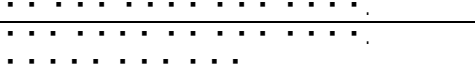
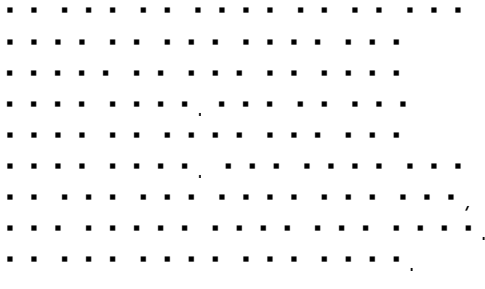



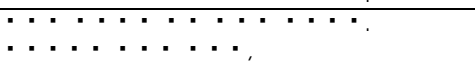
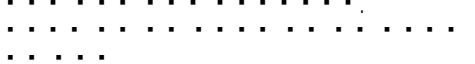
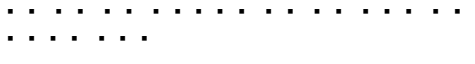

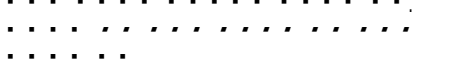
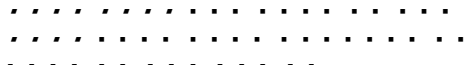
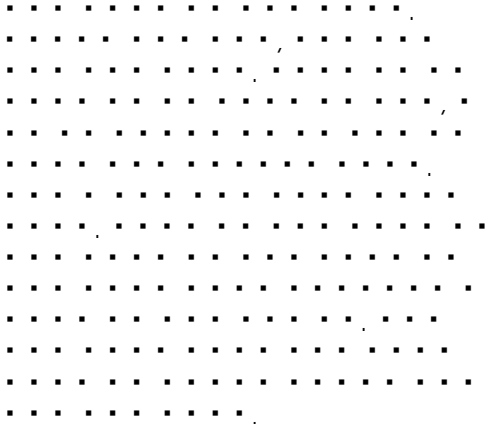

Proposition Analysis of Cancer

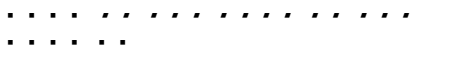
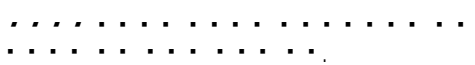
Original Text	Propositions extracted in each paragraph
<p>Imagine that you’re planting a flower garden near your home. After careful planning, you plant snapdragons, geraniums, and petunias exactly where you think they will look best. You also plant a ground ivy that you think will look nice between the flowers. You water your garden and wait for it to grow.</p>	<p>1) Imagine 2) that you’re planting a flower garden 3) A flower garden is near your home. 4) After careful planning, 5) you plant snapdragons, geraniums, and petunias 6) you plant them exactly where you think they will look best. 7) You also plant a ground ivy 8) <i>You also plant a ground ivy</i> that you think will look nice between the flowers. 9) You water your garden and 10) <i>You wait for it to grow.</i></p>
<p>Much to your dismay, after a few months you notice that the ground ivy has taken over the garden.</p>	<p>11) Much to your dismay, 12) after a few months 13) you notice</p>

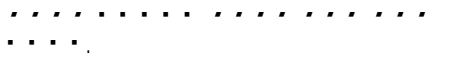
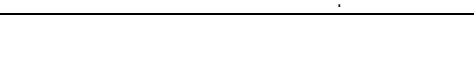
<p>Where there should be flowers, there is nothing but a tangle of vines. Only a few flowers have survived. The ivy has used up more than its share of garden space and soil nutrients. A neighbor remarks, "That vine is so out of control, it's like a cancer."</p>	<p>14) that the ground ivy has taken over the garden. 15) Where there should be flowers, 16) there is nothing but a tangle of vines. 17) Only a few flowers have survived. 18) The ivy has used up more than its share of garden space and 19) <i>The ivy has used up more than its share of soil nutrients.</i> 20) A neighbor remarks, 21) "That vine is so out of control, 22) "it's like a cancer."</p>
<p>Your neighbor compared the ground ivy to a cancer because it grew uncontrollably and destroyed the other plants. Cancer is a disease in which cells grow and divide uncontrollably, damaging the parts of the body around them.</p>	<p>23) Your neighbor compared the ground ivy to a cancer 24) because it grew uncontrollably and 25) <i>because it</i> destroyed the other plants. 26) Cancer is a disease 27) in which cells grow uncontrollably and 28) <i>in which cells</i> divide uncontrollably, 29) damaging the parts of the body around them.</p>
<p>Cancer is actually not just one disease. In fact, there are more than 100 types of cancer. Cancer can occur in almost any part of the body. Cancers are often named by the place in the body where they begin. In the United States today, lung cancer is the leading cause of cancer deaths among both men and women.</p>	<p>30) Cancer is actually not just one disease. 31) In fact, there are more than 100 types of cancer. 32) Cancer can occur in almost any part of the body. 33) Cancers are often named 34) by the place in the body where they begin. 35) In the United States today, lung cancer is the leading cause of cancer deaths among both men and women.</p>
<p>How cancer begins: Scientists think that cancer begins when something damages a portion of the DNA in a chromosome. The damage causes a change in the DNA called mutation. Remember that DNA contains all the instructions necessary for life. Damage to the DNA can cause cells to function abnormally.</p>	<p>36) How cancer begins: 37) Scientists think 38) <i>Scientists think</i> that cancer begins when something damages a portion of the DNA 39) <i>The DNA is</i> in a chromosome. 40) The damage causes a change in the DNA 41) <i>A change is</i> called mutation. 42) Remember that DNA contains all the instructions necessary for life. 43) Damage to the DNA can cause cells to function abnormally.</p>
<p>Normally, the cells in one part of the body live in harmony with the cells around them. Cells that go through the cell cycle divide in a controlled way. Other cells don't divide at all. Cancer begins when mutations disrupt the normal cell cycle, causing cells to divide in an uncontrolled way. The cells stop behaving as they normally do. Without the normal controls on the cell cycle, the cells grow too large and divide too often.</p>	<p>44) Normally, the cells in one part of the body live in harmony with the cells around them. 45) Cells go through the cell cycle. 46) Cells <i>that go through the cell cycle</i> divide in a controlled way. 47) Other cells don't divide at all. 48) Cancer begins 49) when mutations disrupt the normal cell cycle, 50) <i>Mutations</i> causing cells to divide in an</p>

	<p>uncontrolled way.</p> <p>51) The cells stop behaving as they normally do.</p> <p>52) Without the normal controls on the cell cycle,</p> <p>53) the cells grow too large and</p> <p>54) <i>the cells</i> divide too often.</p>
<p>How Cancer Spreads:</p> <p>At first, one cell develops in an abnormal way. As the cell divides, more and more abnormal cells like it grow near it.</p> <p>In time, these cells form a tumor.</p> <p>A tumor is a mass of abnormal cells that develops when cancerous cells divide and grow uncontrollably.</p> <p>Tumors often take years to grow to a noticeable size.</p> <p>During that time the cells become more and more abnormal as they continue to divide. Some of the cancerous cells may break off the tumor and enter the bloodstream.</p> <p>In this way, the cancer can spread to other areas of the body.</p>	<p>55) How Cancer Spreads:</p> <p>56) At first, one cell grows in an abnormal way.</p> <p>57) As the cell divides,</p> <p>58) more and more abnormal cells like it grow near it.</p> <p>59) In time, these cells form a tumor.</p> <p>60) A tumor is a mass of abnormal cells that</p> <p>61) <i>A mass of abnormal cells</i> develops</p> <p>62) when cancerous cells divide uncontrollably and</p> <p>63) <i>when cancerous cells</i> grow uncontrollably.</p> <p>64) Tumors often take years to grow to a noticeable size.</p> <p>65) During that time the cells become more and more abnormal</p> <p>66) as they continue to divide.</p> <p>67) Some of the cancerous cells may break off the tumor and</p> <p>68) <i>Some of the cancerous cells may</i> enter the bloodstream.</p> <p>69) In this way, the cancer can spread to other areas of the body.</p>
<p>Scientists estimate that almost two thirds of all cancer deaths are caused either by tobacco use or unhealthy diets. Smoking is the main cause of lung cancer.</p> <p>When people repeatedly expose their bodies to the chemicals in tobacco, their cells will likely become damaged.</p> <p>Cancer may result.</p>	<p>70) Scientists estimate</p> <p>71) that almost two thirds of all cancer deaths are caused either by tobacco use or</p> <p>72) <i>almost two thirds of all cancer deaths are caused</i> by unhealthy diets.</p> <p>73) Smoking is the main cause of lung cancer.</p> <p>74) When people repeatedly expose their bodies to the chemicals</p> <p>75) <i>The chemicals are</i> in tobacco,</p> <p>76) their cells will likely become damaged.</p> <p>77) Cancer may result.</p>
<p>It might surprise you to learn that unhealthy diets may lead to almost as many cancer deaths as does tobacco.</p> <p>A diet high in fat is especially harmful. Regularly eating high-fat foods, such as fatty meats and fried foods, can put a person at risk for cancer.</p> <p>A diet that includes a lot of fruits, vegetables, and grain products can help lower a person's risk of some types of cancer.</p>	<p>78) It might surprise you to learn</p> <p>79) that unhealthy diets may lead to almost as many cancer deaths <i>as does tobacco</i>.</p> <p>80) Tobacco may lead to many cancer deaths.</p> <p>81) A diet high in fat is especially harmful.</p> <p>82) Regularly eating high-fat foods, <i>such as fatty meats and fried foods</i>, can put a person at risk for cancer.</p> <p>83) <i>High-fat foods include</i> fatty meats and fried foods.</p> <p>84) A diet <i>that includes a lot of fruits, vegetables, and grain products</i> can help lower a person's risk of some types of</p>

	cancer. 85) <i>An example of a healthy diet</i> includes a lot of fruits, vegetables, and grain products.
--	--

	<p>46) </p> <p>47) </p> <p>48) </p> <p>49) </p> <p>50) </p> <p>51) </p> <p>52) </p> <p>53) </p> <p>54) </p> <p>55) </p> <p>56) </p> <p>57) </p> <p>58) </p>
	<p>59) </p> <p>60) </p> <p>61) </p> <p>62) </p> <p>63) </p> <p>64) </p> <p>65) </p> <p>66) </p> <p>67) </p> <p>68) </p>
	<p>69) </p> <p>70) </p> <p>71) </p> <p>72) </p> <p>73) </p> <p>74) </p> <p>75) </p> <p>76) </p> <p>77) </p> <p>78) </p> <p>79) </p> <p>80) </p> <p>81) </p> <p>82) </p> <p>83) </p> <p>84) </p> <p>85) </p>

Glossary

Advance organizer: a stimulus that is presented before learning and contains a system for logically organizing the information into a unified structure (Mayer & Bromage, 1980); a graphic organizer that presents the structure of information in the texts (photosynthesis and respiration)

Bottom-up processing: cognitive processes involved in recognizing words and integrating them into propositions that are consistent with the relationships among words in a given text

Central executive: controlling feature to execute phonological loop and visuospatial sketchpad

Episodic buffer: a memory function that incorporates phonological, visual, and spatial information with resources in long term memory into a unitary episodic representation (Baddeley, 2000)

L1 reading competence: a function of situation model, which includes an ability to make inferences, use strategies, detect inconsistency, and utilize relevant background knowledge

L1MC: an indicator for L1 reading comprehension measured by multiple-choice and true/false questions

L1Rec: an indicator for L1 reading comprehension measured by a recall task

L2 proficiency: a function of textbase, which includes an ability to recognize words and integrate them into propositions that reflect the relationships in a given text

L2CompMC: an indicator for L2 reading comprehension measured by multiple-choice and true/false questions

L2CompRec: an indicator for L2 reading comprehension measured by a recall task

Linguistic Interdependence Hypothesis: a hypothesis that posits one's experience with literacy operation and constructs in either their L1 or L2 can be conducive to the development of literacy skills underlying both languages

Linguistic Threshold Hypothesis: a hypothesis that posits the transfer of one's first language reading skills to the foreign language takes place only when one has reached a threshold level of competence in the target language (L2)

Long-term working memory: a mechanism that stores information in stable form and allows a reader to have a temporary access to it by means of retrieval cues in working memory

Macropropositions: propositions resulting from selection and generalization processes operating on the micropropositions

Micropropositions: propositions directly derived from the text (i.e., phrases and sentences in a given text)

Phonological loop: a system that holds speech-based and possibly purely acoustic information in a temporary store, whose storage is assumed to be dependent on a memory trace that would fade within seconds if not rehearsed in a form of either overt or covert vocalization (Baddeley & Hitch, 1974)

Reading span task: a task to measure a function of central executive in working memory, in which subjects are given a series of sentences to read aloud and

then asked to recall the final word of each sentence; the reading span is the number of final words recalled correctly

Schematic knowledge: a kind of organized background knowledge that can subsume details

Situation model: a mental representation that integrates textual information and background knowledge

Surface structure: exact wordings and syntax used in a given text.

Textbase: elements and relations that are directly derived from the text itself yielding a series of propositions

TOEIC Bridge: a test by Educational Testing Service (ETS) to measure emerging English-language competencies

Top-down processing: cognitive processes of expectation-driven comprehension

Visuospatial sketchpad: the visuospatial sketchpad is concerned with patterns or objects while a spatial component is concerned with location (Baddeley, 2007)

Vocabulary knowledge: knowledge of words in L2, which has a translation equivalent in readers' L1

Working memory: a model with a multi-component nature of memory in the short-term store, which is composed of an attentional control system, the *central executive* along with two slave storage systems, the *phonological loop* and the *visuospatial sketchpad*

Bibliography

- Alderson, J. C., & Banerjee, J. (2002). Language testing & assessment (Part 2). *Language Teaching*, 35, 79-113.
- Alderson, J.C. (1984). Reading in a foreign language: a reading problem or a language problem? In J.C. Alderson & A.H. Urquhart (Eds.). *Reading in a foreign language* (pp. 1-24). London: Longman.
- Anderson, J. R. (1982). Acquisition of cognitive skill. *Psychological Review*, 89, 369-406.
- Anderson, J. R. (1983). *The architecture of cognition*. Cambridge, MA: Harvard University Press.
- Anderson, R.C., & Pearson, P.D. (1984). A schema-theoretic view of basic processes in reading. In P.D. Pearson (Ed.), *Handbook of reading research* (pp. 225-291). New York: Longman.
- Anderson, Wang, & Gaffney, (2006). Comprehension research over the past three decades. In S.E. Israel & G.G. Duffy (Eds.), *Handbook of research on reading comprehension* (pp. 275-283). New York: Routledge.
- Andrade, J. (2001). *Working memory in perspectives*. New York: Psychology Press
- Atkinson, R.C. & Shiffrin, R.M. (1968). Human memory: A proposed system & its control processes. In *The psychology of learning & motivation: advances in research & theory* (K.W. Spence (ed.), vol.2, pp. 89-195. New York: Academic Press.

- Ausubel, D.P. (1960). The use of advance organizers in the learning and retention of meaningful verbal materials. *Journal of Educational Review*, 51, 267-272.
- Ausubel, D.P. (1968). *Educational Psychology: A cognitive view*. New York: Holt, Rinehart & Winston, Inc.
- Baddeley (2007). *Working memory, thought, and action*. New York: Oxford University Press.
- Baddeley A.D. & Hitch, G.J. (1974). Working memory. In G.A. Bower (ed.), *Recent advances in learning and motivation* (Vol. 8, pp.47-89). New York: Academic Press.
- Baddeley, A.D. (2000a). The episodic buffer: a new component of working memory? *Trends in Cognitive Sciences*, 4(11), 417-23.
- Baker, L., & Brown, A.L. (1984). Metacognitive skills and reading. In P.D. Pearson, R. Barr, M. Kamil, & P. Mosenthal (Eds.), *Handbook of Reading Research* (pp. 353-394). New York: Longman.
- Barry, S., & Lazarte, A. (1995). Embedded clause effects on recall: Does high prior knowledge of content domain overcome syntactic complexity in students of Spanish? *The Modern Language Journal*, 79, 491-504.
- Bartlett, F. C. (1932/1995). Remembering; a study in experimental and social psychology. Cambridge [Eng.]: The University press. Chapters V & X.
- Bartlett, F.C. (1932). *Remembering*. Cambridge, England: Cambridge University Press.
- Bernhardt, E.B. (1991). *Reading development in a second language: theoretical, research, and classroom perspectives*. Norwood, NJ: Ablex.

- Bernhardt, E.B. (1999). If reading is reader-based, can there be a computer-adaptive test of reading? In M. Chalhoub-Deville (Ed.), *Issues in computer-adaptive testing of reading proficiency*. (Studies in Language Testing Series, Volume 10) Cambridge: UCLES-Cambridge University Press.
- Bernhardt, E.B., & Kamil, M. (1995). Interpreting relationships between L1 and L2 reading: Consolidating the linguistic threshold and the linguistic interdependence hypotheses. *Applied Linguistics, 16*, 15-34.
- Bernhardt, E .B. (2000). Second-language reading as a case study of reading scholarship in the 20th century. In M.L. Kamil, P.B. Mosenthal, P .D. Pearson, & R. Barr(Eds.). *Hand book of reading research* (Vol. 3, pp. 791-812). Mahwah, NJ: Erlbaum.
- Bernhardt, E.B. (2003). Challenges to reading research from a multilingual world. *Reading Research Quarterly, 38*, 112-117.
- Block, E. L. (1992). See how they read: comprehension monitoring of L1 and L2 readers. *TESOL Quarterly, 20*, 463-494.
- Bossers, B. (1991). On thresholds, ceilings and short circuits: The relation between L1 reading, L2 reading, and L1 knowledge. In J.Hulstijn & J.Matter (Eds.), *AILA Review, 8*, 45-60.
- Bransford, J. D., & Schwartz, D. L. (1999). Rethinking transfer: A simple proposal with multiple implications. In *Review of Research in Education, 24* 1999 (Vol. 24, pp. 61-100).
- Brisbois, J.E. (1995). Connections between first- and second-language reading. *Journal of Reading Behavior, 27* (4), 565-584.

- Britton, B.K. & Glynn, S.M. (1982). Effects of text structure on use of cognitive capacity during reading. *Journal of Educational Psychology, 74*, 51-61.
- Bugel, K., & Buunk, B. (1996). Sex differences in foreign language text comprehension: The role of interests and prior knowledge. *The Modern Language Journal, 80*, 15-31.
- Cain, K., Oakhill, J., & Bryant, P. (2004). Children's reading comprehension ability: Concurrent prediction by working memory, verbal ability, and component skills. *Journal of Educational Psychology, 96*, 31-42.
- Carlson, R, Chandler, P., & Sweller, J. (2003). Learning and understanding science instructional material. *Journal of Educational Psychology, 95*, 629-640.
- Carrell, P. L. (1983). Three components of background knowledge in reading comprehension. *Language Learning, 33*, 183-207.
- Carrell, P., Devine, H., & Eskey, D. (1998). Interactive approaches to second language reading. New York. Cambridge University Press Day.
- Carrell, P., & Wise, T. (1998). The relationship between prior knowledge and topic interest in second language reading. *Studies in Second Language Acquisition, 20*, 285-309.
- Carrell, P.L. (1991). Second language reading: reading ability or language proficiency? *Applied Linguistics, 12*, 159-179.
- Chambliss, M. & Calfee, R.C. (1998). *Textbooks for learning: Nurturing children's mind*. Malden, M.A.: Blackwell Publishers Inc.

- Chase, W.G. & Ericsson, K.A. (1982). Skill and working memory. In G.H. Bower (Eds.), *The psychology of learning and motivation*. New York: Academic Press.
- Chase, W.G., & Simon, H.A. (1973). The mind's eye in chess. In W.G. Chase (ed.), *Visual information processing* (pp. 215-281). New York: Academic Press.
- Chen, Q. & Donin, J. (1997). Discourse processing of first and second language biology texts: Effects of language proficiency and domain-specific knowledge. *The Modern Language Journal*, 81, 209-227.
- Chi, M. T. H., Glaser, R., & Rees, E. (1982). Expertise in problem solving. In R. Sternberg (Ed.), *Advances in the psychology of human intelligence* (Vol. 1, pp. 7-75). Hillsdale, NJ: Lawrence Erlbaum Associates.
- Chikamatsu, N. (1996). The effects of L1 orthography on L2 word recognition: A study of American and Chinese learners of Japanese. *Studies in Second Language Acquisition*, 18, 403-432.
- Clark, C.H. & Bean, T.W. (1982). Improving advance organizer research: Persistent problems and future directions. *Reading World*, 22, 2-10.
- Clarke, M.A. (1979). Reading in Spanish and English: evidence from adult ESL students. *Language Learning*, 29, 121-150.
- Cohen, A. D. (1998). *Strategies in learning and using a second language*. New York: Longman.
- Conway, A.R.A., Kane, M.J., & Engle, R.W. (2003). Working memory capacity and its relation to general intelligence, *Trends in Cognitive Science*, 7 (12), 547-552).

- Corkhill, A.J. (1992). Advance organizers: Facilitators of recall. *Educational Psychology Review*, 4, 33-67.
- Cummins, J. (1979). Cognitive academic language proficiency, linguistic interdependence, the optimum age question and some other matters. *Working Papers on Bilingualism*, 19, 197-205.
- Cummins, J. (1981). *Bilingualism and minority-language children: Language and literacy series*. Toronto: Ontario Institute for Studies in Education.
- Daneman, M. & Carpenter, P.A. (1980). Individual differences in working memory and reading. *Journal of Verbal Learning and Verbal Behavior*, 19, 450-66.
- DeKeyser, R. (2007). Skill acquisition theory. In B. VanPatten & J. Williams (Eds.), *Theories in Second Language Acquisition: An Introduction* (pp. 97-113). New Jersey: Lawrence Erlbaum Assoc Inc.
- DeKeyser, R. (2009). Cognitive-psychological processes in second language learning. In M. H. Long & C.J. Doughty (eds.), *Hand of Language Teaching*, (pp. 119-138). Singapore: Blackwell Publishing Ltd.
- Della Sala, S. & Logie, R.H. (2002). Neuropsychological impairments of visual and spatial working memory. In A.D. Baddeley, M.D. Kopelman & B.A. Wilson (eds.), *Handbook of memory disorders*, (pp. 271-92). Chichester: Wiley.
- Ericsson, K. A., & Delaney, P. F. (1999). Long-term working memory as an alternative to capacity models of working memory in everyday skilled performance. In A. Miyake & P. Shah (Eds.), *Models of Working Memory: Mechanisms of Active Maintenance and Executive Control* (pp. 257-297), Cambridge, UK: Cambridge University Press.

- Ericsson, K.A. & Kintsch, W. (1995). Long-term working memory. *Psychological Review*, *102*(2), 211-245.
- Fiez, J.A. Raife, E.A., Balota, E.A., Schwarz, J.P., Raichle, M.E., & Petersen, S.E. (1996). A positron emission tomography study of the short-term maintenance of verbal information. *Journal of Neuroscience*, *16*, 808-822.
- Fischer, B., & Glanzer, M. (1986). Short-term storage and the processing of cohesion and during reading. *Quarterly Journal of Experimental Psychology*, *38*, 431-60.
- Gathercole, S.E., Willis, C., Emslie, H., & Baddeley, A.D. (1992). Phonological memory and vocabulary development during the early school years: A longitudinal study. *Developmental Psychology*, *28*, 887-898.
- Glanzer, M., Dorfman, D, & Kaplan, B. (1981). Short-term storage in the processing of text. *Journal of Verbal Learning and Verbal Behavior*, *20*, 656-70.
- Glanzer, M., Fischer, B., & Dorfman, D. (1984). Short-term storage in reading. *Journal of Verbal Learning and Verbal Behavior*, *23*, 467-86.
- Gough, P.B., Juel, C., & Griffith, P. (1992). Reading, spelling, and the orthographic cipher. In P. Gough, L. Ehri, & R. Treiman (Eds.), *Reading acquisition* (pp. 35-48). Hillsdale, NJ: Erlbaum.
- Graesser, A.C., & Kreuz, R.J. (1993). A theory of inference generation during text comprehension. *Discourse Processes*, *16*, 145-160.
- Guerrero, M. C. M. (2005). *Inner speech – L2: thinking words in a second language*. New York: Springer Science and Business Media, Inc.

- Hamada, M., & Koda, K. (2008). Influence of First Language Orthographic Experience on Second Language Decoding and Word Learning. *Language Learning, 58*, 1-31.
- Hambrick, D. Z., & Engle, R. W. (2002). Effects of domain knowledge, working memory capacity, and age on cognitive performance: An investigation of the knowledge-is-power hypothesis. *Cognitive Psychology, 44*, 339-387.
- Hammadou, J. (1991). Interrelationships among prior knowledge, inference, and language proficiency in foreign language reading. *The Modern Language Journal, 75* (1), 27-38.
- Hannon & Daneman (2006). What do tests of reading comprehension ability such as the VSAT really measure?: a componential analysis. In Mitel, A.V. (ed.), *Trends in educational psychology* (pp. 1-43). New York: Nova Science Publishers.
- Hannon, N., & Daneman, M. (2001). A new tool for measuring and understanding individual differences in the component processes of reading comprehension. *Journal of Educational Psychology, 93*, 103-128.
- Harrington, M., & Sawyer, M. (1992). L2 working memory capacity and L2 reading skill. *Studies in Second Language Acquisition, 14*, 25-38.
- Horiba, Y. (1996.). Comprehension Processes in L2 Reading: Language Competence, Textual Coherence, and Inferences. *Studies in Second Language Acquisition, 18*, 433-473.
- Janssen-van Dieten, A. (e.a.) (1988). *Instaptoets Anderstalige Volwassenen*. CTTO/KUN-ITT: Arnhem.

- Jiang, N. (2000). Lexical representation and development in a second language. *Applied Linguistics, 21*, 47-77.
- Johnson, P. (1982). Effects on reading comprehension of language complexity and cultural background of text. *TESOL Quarterly, 16*, 169-181.
- Jonides, J., Smith, E.E., Koeppe, R.A., Awh, E., Minoshima, S. & Mintun, M. (1993). Spatial working memory in humans as revealed by PET. *Nature, 363*, 623-5.
- Jonides, J., Smith, E.E., Marshuetz, C., Koeppe, R.A., & Reuter-Lorenz, P.A. (1998). Inhibition in verbal working memory revealed by brain activation. *Psychology, 95(14)*, 8410-8413.
- Kaakinen, J.K., Hyona, J., & Keenan, J.M. (2003). How prior knowledge, WMC, and relevance of information affect eye fixations in expository text. *Journal of Experimental Psychology, 29*, 447-457.
- Kintsch, W. & Kintsch, E. (2005). Comprehension. In Paris, S.G. & Stahl, S.A. (eds.), *Children's reading comprehension and assessment* (pp. 71-92). Mahwah, NJ.: Lawrence Erlbaum Associates.
- Kintsch, W. (1988). The role of knowledge in discourse processing: A construction-integration model. *Psychological Review, 95*, 163-182.
- Kintsch, W. (1993). Information accretion and reduction in text processing: Inferences. *Discourse Processes, 16*, 193-202.
- Kintsch, W. (1998). *Comprehension: A paradigm for cognition*. Cambridge, England: Cambridge University Press.

- Kintsch, W. (2005). Components of comprehension: a convergence between memory-based processes and explanation-based processes. *Discourse Processes*, 39 (2&3), 123-128.
- Koda, K. (1996). L2 word recognition research: a critical review. *Modern Language Journal*, 80, 450-460.
- Koda, K. (2007). Reading and language learning: Crosslinguistic constraints on second language reading development. *Language Learning*, 57, 1-44.
- Kotovsky, K., Hayes, J.R., & Simon, H.A. (1985). Why Are Some Problems Hard? Evidence From the Tower of Hanoi. *Cognitive Psychology*, 17, 284-294.
- Kulhavy, R.W., Lee, J.B., & Caterino, L.C. (1985). Conjoint retention of maps and related discourse. *Contemporary Educational Psychology*, 10, 28-37.
- Kyllonen, P.C. & Christal, R.E. (1990). Reasoning ability is (little more than) working-memory capacity? *Intelligence*, 14, 389-433.
- Langan-Fox, J., Waycott, J.L., & Albert, K. (2000). Linear and graphic advance organizers: properties and processing. *International Journal of Cognitive Ergonomics*, 4, 19-34.
- Larkin, J., McDermott, J., Simon, D. P., & Simon, H. A. (1980). Expert and novice performance in solving physics problems. *Science*, 208, 1335-1342.
- Lee, J. F. (1986). Background knowledge and L2 reading. *Modern Language Journal*, 70, 350-354.
- Leontiev, (1981). *Psychology and the language learning process*. New York: Pergamon.

- Lesser, M. (2007). Learner-based factors in L2 reading comprehension and processing grammatical form: topic familiarity and working memory. *Language Learning, 57*(2), 229-270.
- Luiten, J., Ames, W. & Ackerson, G. (1980). A meta-analysis of the effects of advance organizers on learning and retention. *American Educational Research Journal, 17*, 211-218.
- Marcus, N. , Copper, M, & Sweller, J. (1996). Understanding instructions. *Journal of Educational Psychology, 88*, 49-63.
- Mayer, R.E. & Bromage, B.K. (1980). Different recall protocols for technical texts due to advance organizers. *Journal of Educational Psychology, 72*, 209-225.
- Mayer, R.E. (1987). *Educational psychology: A cognitive approach*. Boston: Little, Brown, and Company.
- Miller, G. A. (1956). The magical number seven plus or minus two: some limits on our capacity for processing information. *Psychological Review, 63*, 81–97.
- Miller, G.A., Glanter, E. & Pribram, K.H. (1960). *Plans and the structure of behavior*. New York: Holt, Rinehart & Winston.
- Miller, L.M.S., Cohen, J.A., & Wingfield, A. (2006). Contextual knowledge reduces demands on working memory during reading. *Memory and Cognition, 34*, 1355-1367.
- Mislevy, R. (2007). *Toward a Test Theory for the Internationalist Era*. Presented at the Language Testing Research Colloquium, Barcelona, Spain, June 9, 2007 for the Samuel J. Messick Memorial Lecture.

- Mislevy, R. (2008). Issues of structure and issues of scale in assessment from a situative/sociocultural perspective. In P.A. Moss, D.C. Pullin, J.P. Gee, E.H. Haertel, and L.J. Young (Eds.), *Assessment, equity, and opportunity to learn* (pp. 259-294). New York: Cambridge University Press.
- Mislevy, R.J. & Risconscente, M. (2006). Evidence-centered assessment design: Layers, concepts, and terminology. In S. Downing & T. Haladyna (Eds.), *Handbook of Test Development*. Mahwah, NJ: Erlbaum.
- Mislevy, R.J., Steinberg, L.S., & Almond, R.A. (2003). On the structure of educational assessments [OSEA]. *Measurement: Interdisciplinary Research and Perspectives, 1*, 3-66.
- Osaka, M. & Osaka, N. (1994). Working memory capacity related to reading: Measurement with the Japanese version of reading span test. *Japanese Journal of Psychology, 65*, 339-345.
- Osaka, M., & Osaka, N. (1992). Language-independent working memory as measured by Japanese and English reading span tests. *Bulletin of the Psychonomic Society, 30*, 287-289.
- Osaka, M., Nishizaki, Y., & Komori, M. (2002). Effect of focus on verbal working memory: Critical role of the focus word in reading. *Memory and Cognition, 30*, 562-571.
- Paivio, A. (1986). *Mental representations: A dual coding approach*. Oxford: Oxford University Press.
- Palincsar, A. S., & Brown, A. L. (1984). Reciprocal teaching of comprehension-fostering and monitoring activities. *Cognition and Instruction, 1*, 117-175.

- Palincsar, A.S., & Brown, A.L. (1984). Reciprocal teaching of comprehension-fostering and monitoring activities. *Cognition and Instruction, 1*, 117-175.
- Pass, F., Renkl, A., & Sweller, J. (2003). Cognitive load theory and instructional design: Recent developments. *Educational Psychologist, 38*, 1-4.
- Peretz, A. S., & Shoham, M. (1990). Testing reading comprehension in LSP. *Reading in a foreign language, 7*, 447-55.
- Perfetti, C.A. (1985). *Reading ability*. New York: Oxford University Press.
- Pollock, E. et al. (2002). Assimilating complex information. *Learning and Instruction, 12*, 61-86.
- Pressley, M. & Afflerbach, P. (1995). *Verbal protocols of reading: The nature of constructively responsive reading*. Hillsdale, New Jersey: Lawrence Erlbaum Associates.
- Pulido, D. C. (2004). The relationship between text comprehension and second language incidental vocabulary acquisition: A matter of topic familiarity? *Language Learning, 54*, 469-523.
- Rack, J.P., Hulme, C. Snowling, M.J. & Wightman, J. (1994). The role of phonology in young children's learning of sight words: the direct mapping hypothesis. *Journal of Experimental Child Psychology, 57*, 42-71.
- Raney, G.E., Obeidallah, S.M., & Miura, T.K. (2002). Text comprehension in bilinguals: integrating perspectives on language representation and text processing. In Heredia, R.R. & Altarrida, J (eds.), *Advances in psychology* (165-183).

- Robinson, D. H., Robinson, S. L., & Katayama, A. D. (1999). When words are represented in memory like pictures: evidence for spatial encoding of study materials. *Contemporary Educational Psychology, 24*, 38-54.
- Robinson, D.H. & Kiewra, K.A. (1995). Visual argument: Graphic organizers are superior to outlines in improving learning from text. *Journal of Educational Psychology, 87*, 455-467.
- Rosenblatt, L.M. (1938). *Literature as exploration*. New York: Modern Language Association.
- Rosenblatt, L.M. (1978). *The reader, the text, the poem: The transactional theory of the literacy work*. Carbondale: Southern Illinois University Press.
- Royer J.M., & Carlo, M.S. (1991). Transfer of comprehension skills from native to second language. *Journal of Reading, 34*, 450-455.
- Schneider, W. & R. M. Shiffrin. (1977). Controlled and automatic human information processing: Detection, search, and attention. *Psychological Review, 84*, 1-66.
- Share, D. L., & Stanovich, K. E. (1995). Cognitive processes in early reading development: A model of acquisition and individual differences. *Issues in Education: Contributions from Educational Psychology, 1*, 1-57.
- Siegel, L.S. & Ryan, E.B. (1988). The Development of Working Memory in Normally Achieving and Subtypes of Learning Disabled Children. *Child Development, 60* (4), pp. 973-980
- Smith, E.E. & Jonides J. (1999). Storage and executive processes in the frontal lobes. *Science, 283*, 1657–1661.

- Smith, E.E. & Jonides, J. (1997). Working memory: a view from neuroimaging. *Cognitive Psychology*, 33, 5-42.
- Stanovich, K. E. (1986). Matthew effects in reading: some consequences of individual differences in the acquisition of literacy. *Reading Research Quarterly* 21, 360-407.
- Stanovich, K. E. (1988). Explaining the differences between the dyslexic and the garden-variety poor reader: the phonological-core variable. *Journal of Learning Disabilities* 21 (10), 590-604.
- Stanovich, K. E. (1992). Speculations on the causes and consequences of individual differences in early reading acquisition. In L. C. Ehri & P. B. Gough (Eds.), *Reading acquisition* (pp. 307–342). Hillsdale, NJ: Erlbaum.
- Stone, C.L. (1983). A meta-analysis of advance organizer studies. *Journal of Experimental Education*, 51, 194-199.
- Swanson, H.L. (1992). Generality and modifiability of working memory among skilled and less skilled readers. *Journal of Educational Psychology*, 84, 473-488.
- Swanson, H.L. (1995). *The cognitive process test (S-CPT)*. Austin, TX: PRO-ED.
- Swanson, H.L., & Howell, M. (2001). Working memory, short-term memory, and speech rate as predictors of children's reading performance at different ages. *Journal of Educational Psychology*, 93, 720-734.
- Sweller, J. & Chandler, P. (1994). Why some material is difficult to learn. *Cognition and Instruction*, 12, 185-233.

- Tang, H. (1997). The relationship between reading comprehension processes in L1 and L2. *Reading Psychology, 18*, 249-301.
- Thorn, A.S.C. & Gathercole, S. (1999). Language-specific knowledge and short-term memory in bilingual and non-bilingual children. *Quarterly Journal of Experimental Psychology, 52A*, 303-24.
- Tindall-Ford, S., Chandler, P., & Sweller, J. (1997). When two sensory modes are better than one. *Journal of Experimental Psychology: Applied, 3*, 257-287.
- Townsend, M.A. & Clarihew, A. (1989). Facilitating children's comprehension through the use of advance organizers. *Journal of Reading Behavior, 21*, 15-35.
- van den Broek, P, Fletcher, C.R., & Risdén, K. (1993). Investigations of inferential processes in reading: A theoretical and methodological integration. *Discourse Processes, 16*, 169-180.
- van Merriënboer, J.J.G. & Sweller, J. (2005). Cognitive load theory and complex learning: recent developments and future directions. *Educational Psychology Review, 17*, 147-177.
- Waller, R. (1981). *Understanding network diagrams*. Paper presented at the annual meeting of the American Educational Research Association, Los Angeles, CA.