

# TECHNICAL RESEARCH REPORT

Report on Selected Standardization Activities of the IEEE  
BASC and of the ATM Forum

*by A. Makowski, P. Narayan, J. Kim, M.G. Ryu,  
T. Christofili, G. Charleston, S. Rao*

**CSHCN T.R. 95-13  
(ISR T.R. 95-110)**



*The Center for Satellite and Hybrid Communication Networks is a NASA-sponsored Commercial Space Center also supported by the Department of Defense (DOD), industry, the State of Maryland, the University of Maryland and the Institute for Systems Research. This document is a technical report in the CSHCN series originating at the University of Maryland.*

**Web site <http://www.isr.umd.edu/CSHCN/>**

# **Report on Selected Standardization Activities of the IEEE BASC and of the ATM Forum**

Jangkyung Kim ; *jkkim@src.umd.edu, jkkim@pec.etri.re.kr*  
Protocol Engineering Center  
Electronics & Telecommunications Research Institute  
Yousong-Gu P.O. Box 106  
Taejon, 305-606, Korea

Release 1.0  
June 1995

Laboratory  
for  
Advanced Switching Technologies

ISR, University of Maryland  
College Park, MD 20742

Project team members:

Dr. Armand Makowski	ISR, UMCP
Dr. Prakash Narayan	ISR, UMCP
Dr. Jangkyung Kim	ETRI, Korea
Mr. Man Geun Ryu	Modacom, Korea
Mr. Thomas Christofili	ISR, UMCP
Mr. Giles Charleston	ISR, UMCP
Mr. Sandeep Rao	ISR, UMCP

© Copyright, Laboratory for Advanced Switching Technologies

The Laboratory for Advanced Switching Technologies reserves the right on the contents of this document. No part of this document may be reproduced or utilized in any form or by any means, electronic or mechanical, including photocopying, recording, or by any information storage and retrieval system, without permission from the Laboratory for Advanced Switching Technologies in ISR, UMCP

## 1. Introduction

This document describes the standardization activities which were performed during the first year period of the joint project named "A Standardization and Research Project on an ATM/B-ISDN Switching Fabric System" that is being jointly performed by Protocol Engineering Center (PEC) of Electronics and Telecommunications Research Institute (ETRI), Institute for System Research (ISR) of the University of Maryland at College Park (UMCP) and Modacom Co., Ltd. These standardization activities are related to the IEEE Bus Architecture Standards Committee(BASC) meetings and ATM Forum Meetings. This document also provides the general information about the IEEE Standards meetings and ATM Forum Standards meetings.

### 1.1 Standardization Activities of the Joint Project

The main goal of this joint project is to design the ATM LAN Access Switch (ALAX) whose function is to provide the interface between legacy LAN and ATM world as shown in Figure 1. To provide this functionality to the ALAX system, we need to implement the protocols which are in the standardization process in the IEEE BASC meetings and ATM Forum meetings. Therefore, we participated in the standard meetings and collected the information needed for this project. In the future, we will contribute to these standards meetings by submitting the protocol standards which will be developed during the designing process of ALAX system. By doing these activities, we can achieve the goals of this project which are the development of the leading edge products and the accomplishments of the advanced standardization activities. And this standardization activities can be the good model case for the advanced standardization research efforts in the Protocol Engineering Center (PEC) of Electronics and Telecommunications Research Institute (ETRI) of Korea.

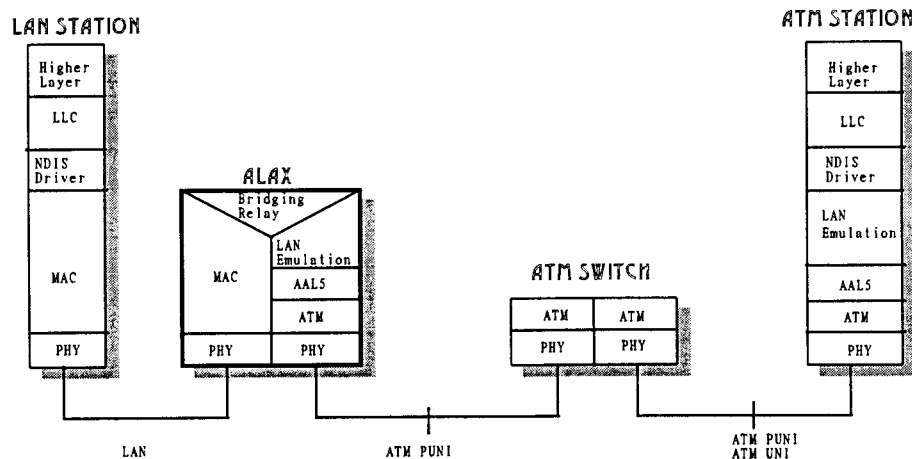

Figure 1. Network Architecture of the ALAX

## 1.2 Overview of the ALAX System

### 1.2.1 Network Architecture of the ALAX

The main function of the ALAX is to provide the interface between legacy LAN and ATM world as well as between LAN and LAN. The functions and architecture of the ALAX are described in detail in the documentations named *ATM LAN Access Switch: Protocol Architecture (LAN Emulation Version)*<sup>[1]</sup> and *ATM LAN Access Switch: System Architecture*<sup>[2]</sup>. Figure 1 shows the network architecture of the communication network environment in which the ALAX resides.

ALAX system will be built on the PCI Bus<sup>[3][4][5][6]</sup> based IBM PC with the IEEE P1355<sup>[7]</sup> serial bus data communication capability in it. The protocols needed within the LAN Emulation version of the ALAX include LAN Emulation, Bridging Relay function, P1355, MAC, LAN Physical, AAL5, ATM and ATM Physical layer<sup>[8][9][10]</sup>. The conversion protocol between P1355 and MAC which is named MAC Mapping Layer (MML) protocol are also needed. Other protocols needed in the ALAX include the ATM signaling which is defined in ATM Forum UNI 3.0<sup>[11]</sup>, Network Management(SNMP<sup>[12]</sup> or CMIP) and some control functions of the ALAX. All the protocols described above should be located in the different adaptor boards of the ALAX system and run. Figure 2 shows the locations of all of the protocols which reside in the ALAX system.

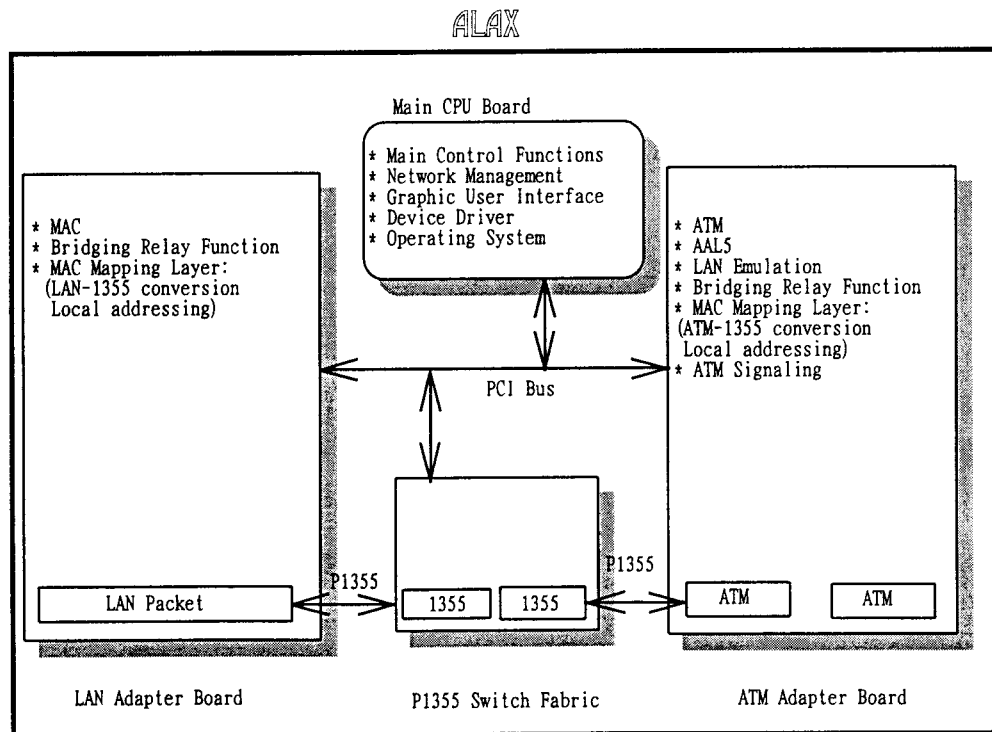

Figure 2. Protocols of the ALAX

### 1.2.2 Packet Conversion within the ALAX

The format of the packets in the LAN environment and ATM environment are different. Therefore, the main function of the ALAX is to convert the input packet to the proper output packet format. All the packets which are transferred through the ALAX should have the P1355 packet format as shown in Figure 2. The packet from the LAN side has the IEEE 802.3<sup>[13][14]</sup> Ethernet MAC format. Therefore, this packet should be converted to the P1355 packet first then it should be converted to the ATM cell format before it is sent out to the ATM network. On the other hand, the ATM cells arrived at the ALAX should also be converted to the P1355 packets then to LAN packets. There are many things that should be considered during this procedure. They are addressing, routing, packet format etc. and are described in the documentation named *ATM LAN Access Switch: Protocol Architecture (LAN Emulation Version)*<sup>[1]</sup> in detail.

## **2. Standardization Activities of the Project**

### **2.1 Relationship between the Standardization Activities and the System Design**

The main goal of the joint project named "A Standardization and Research Project on an ATM/B-ISDN Switching Fabric System" is to design an ATM LAN Access Switch (ALAX) which provides the interface between legacy LANs and ATM world. To provide this functionality to the ALAX system, we need to implement the protocols which are in the standardization process in the IEEE BASC meetings and ATM Forum meetings.

The most important design characteristics of the ALAX is the adoption of the IEEE P1355 Standard for Heterogeneous Inter Connect(HIC) as the data communication paths within the ALAX switching system. This makes it possible for this project team to design the PC-based parallel architected high performance switching system in conformance with emerging open technologies and related standards. The standardization activities related to the IEEE P1355 are performed at the IEEE BASC standards meetings and we participated in this meetings two times.

There can be many design options to build the ALAX system. We decided to implement two versions of the ALAX system as the design options. One is the LAN Emulation<sup>[15]</sup> version and the other is Multi Protocol Over ATM version. The LAN Emulation protocol is now on the standardization procedure at the LAN Emulation SWG Drafting Group of the ATM Forum Technical Meeting Committee. The MPOA protocol is also on the standardization procedure at the Multiprotocol Sub-Working Group of the ATM Forum Technical Meeting Committee. Therefore, we participated in the ATM Forum meeting to apply the results of the ATM Forum into the ALAX system design.

### **2.2 Standardization Activities at IEEE BASC Meetings**

We adopted the IEEE P1355 Standard for Heterogeneous Inter Connect(HIC) as the data communication paths within the ALAX switching system. The IEEE P1355 is a new serial bus standard that provides the data interconnect between communication modules with scalability, flexibility and simplicity<sup>[7]</sup>. The purpose of P1355 standard is to enable the high-performance, scalable, modular, parallel systems to be constructed with low system integration cost. By adopting the P1355 serial bus into this system, the bottleneck problem within the high-speed communication system can be solved.

To implement the IEEE P1355 protocol into the ALAX system, we needed to follow the standardization activities of the IEEE P1357 and IEEE P1355. IEEE P1357 is the "Standard for Logical Interconnection of Multi-Protocol Plug-In Modules Supporting Asynchronous Transfer Mode (ATM)". The standardization activities related to the IEEE P1355 are performed at the IEEE Bus Architecture Standards Committee (BASC) standards meetings and this project team participated in these meetings two times during the first year period of the project.

The IEEE BASC meetings has many sub working groups. Among these working groups, this project team participated in the IEEE P1355 working group meeting, IEEE P1356 working group meeting, IEEE P1357 working group meeting and IEEE P896.11 working group meeting. The details of this meeting groups are described in Chapter 3.

### **2.3 Standardization Activities at ATM Forum**

Some significant progress for the inter networking problem between legacy LAN and ATM was done in the ATM Forum. They are Multi Protocol Over ATM(MPOA) and LAN Emulation(LANE). The first phase of the ALAX design is focused on the LAN Emulation environment. The function of the ALAX will be

the ATM hub which conveys the LAN packets to the ATM world as well as the ATM cells to the legacy LAN environment. ALAX will also connect two separate legacy LANs by conveying the LAN packets between those legacy LANs. The LAN to ATM interface protocol of the first phase ALAX will be the LAN Emulation which is now documented as LAN Emulation Over ATM Specification - Version 0 by the LAN Emulation SWG Drafting Group at the ATM Forum<sup>[15]</sup>. The legacy LAN which we are considering in the first phase is the IEEE 802.3 Ethernet LAN<sup>[13]</sup>. The network architecture of the LAN emulation environment is shown in Figure 1.

### 2.3.1 LAN Emulation

In order to use the vast base of existing LAN application software, it is necessary to define an ATM service, called "LAN Emulation," that emulates services of existing LANs across an ATM network and can be supported via a software layer in end systems. In the first phase of the ALAX design, we decided to use the LAN Emulation as the conversion protocols between the legacy LANs and the ATM. If such a LAN Emulation service is provided for an ATM network, then end systems can connect to the ATM network while the software applications interact as if they are attached to a traditional LAN. Also, this service will support interconnection of ATM networks with traditional LANs by means of today's bridging methods. Therefore, ALAX will allow interoperability between software applications residing on ATM-attached end systems and on traditional LAN end systems. Currently, "LAN Emulation Over ATM Specification - version 0" was finished in the LAN Emulation SWG Drafting Group and many companies began to provide the LAN Emulation software to the market.

### 2.3.2 ATM Signaling

As shown in Figure 1., ALAX is connected to the ATM network using the Private UNI(P-UNI) specification defined in the ATM Forum. Private UNI will typically be used to interconnect an ATM user with an ATM switch that is managed as part of the same corporate network. ATM signaling specifies the procedures for dynamically establishing, maintaining and clearing ATM connections at the User-Network Interface. The procedure are defined in terms of messages and the information elements used to characterize the ATM connection and ensure interoperability. One of the way we can implement the ATM signaling is to modify the VINCE(Vendor Independent Network Control Entity)<sup>[16][17][18]</sup> which is a publicly available software package for the development of protocols in ATM networks. The other way is to purchase the ATM signaling software and port it to the ALAX system.

### 2.3.3 Multi Protocol Over ATM (MPOA)

MPOA is an effort taking place in the ATM Forum to standardize protocols for the purpose of running multiple Network Layer protocols over ATM. Next version of the ALAX will implement the MPOA into the system which can support existing network layer protocols like IP, IPX, etc.



### **3. IEEE Standardization Activities**

#### **3.1 Introduction of IEEE Standards**

##### **3.1.1. IEEE Standards Boards**

The Institute of Electrical and Electronics Engineers (IEEE) is the world's largest professional society, with some 275,000 members. Its activities are organized under a number of boards, one of which is the IEEE Standards Board. The Standards Board directs the development of IEEE standards. The IEEE is accredited by ANSI for the development of standards and IEEE standards are submitted to ANSI for consideration as national standards. Standards work in the areas of communications and information systems is performed primarily by committees set up under the IEEE Communications Society and the IEEE Computer Society.

The development of standards within the IEEE is performed by participating members and the results are balloted among interested professional members. The result is that IEEE standards have reached a consensus acceptable to ANSI and are quickly adopted as national standards. The time period between the start of a project and the adoption as a national standard is generally shorter under the IEEE process than under the X3 process.

##### **3.1.2. The Scope of IEEE Standardization<sup>[19]</sup>**

The scope of IEEE standardization activities falls within the technological fields stated in the IEEE Constitution: the advancement of the theory and practice of electrical engineering, electronics, radio and the allied branches of engineering, and the related arts and sciences. This scope includes the defined scopes of the Societies and Technical Committees. As a transnational organization, IEEE strives to generate standards publications that will have the broadest potential international acceptance.

The IEEE Standards Board has overall responsibility for all standards development and approval for which the IEEE is ultimately responsible, and sole responsibility for appointment to and participation in, and cooperation with, other organizations on all standards matters.

##### **3.1.3 Purpose of IEEE Standardization**

IEEE standards provide a common ground for communication among engineers and scientists in some specific area of electrotechnology. They also provide criteria for the acceptable performance of equipment or materials pertinent to the field of electrotechnology. The purpose of the review by the IEEE Standards Board is to ensure that IEEE standards represent a consensus of interests substantially concerned with or potentially affected by these standards and that proper procedures have been carried out in formulation of the standards.

##### **3.1.4 Relationship with National Standards Bodies<sup>[20]</sup>**

The IEEE is an accredited organization under the American National Standards Institute (ANSI) Procedures, and as such may submit approved IEEE standards to ANSI's Board of Standards Review (BSR) for recognition. IEEE standards, which are developed all over the world by IEEE members, may be submitted to any national standards body for recognition by that national body as its national standard.

#### **3.2 Introduction of IEEE BASC Meeting**

IEEE Bus Architecture Standard Committee (BASC) deals with the high-speed bus architecture related standardization activities. These high-speed bus architectures are standardized to satisfy the requirements of

the future high-speed computer system and communication system. The working group of the IEEE BASC include the followings:

- P896.10 Standard for FutureBus+ Spaceborne Systems
- P896.11 Standard for IEEE 1355 Links on FutureBus+ Backplane Connector
- P896.12 Standard for Fault Tolerance Classification
- P1101.4a SEM-E ERRATA
- P1101.5 Standard Mechanical Interface for Military Module
- P1101.6 Standard Mechanical Interface for a 10SU Module
- P1101.8 Standard for 10SU Liquid -flow- Through Cooling
- P1101.9 Standard for Liquid -flow- Through Cooling
- P1156.4 Standard for Spaceborne Computer Modules
- P1355 Standard for Heterogeneous InterConnect (HIC)
- P1355.1 Standard Protocols for HIC on the UTP
- P1356/ 896 A Standard Profile for Multiprotocol Plug-in Modules, ATM
- P1357 A Logical Interconnection Standard for Multi-protocol
- P1393 Standard for Spaceborne Fiber Optic Data Bus
- AFSG Air Flow Study Group

Among above sub working groups of the BASC, this project team participated in the following sub working groups.

### 3.2.1 IEEE P1355

IEEE P1355 is the standard for Heterogeneous InterConnect (HIC) which is the low cost, low latency scalable serial interconnect for parallel system construction. This protocol was also submitted to the ISO/IEC JTC1 standard committee and accepted as the standard. IEEE P1355 specifies the physical connectors and cables to be used, the electrical properties of the interconnect and a cleanly-separated set of logical protocols to perform the interconnection in the simplest possible way. The purpose of this standard is to enable high-performance, scalable, modular, parallel systems to be constructed with low cost, where 'cost' must include not only the price of components, but also the engineering effort required to use them successfully. In ALAX, the P1355 is used to interconnect many modules within the system.

### 3.2.2 IEEE P1357<sup>[21]</sup>

The primary goal of the P1357 project is to define a standard logical layer for an ATM cell based protocol. This protocol must provide for the addressing of both local and remote users by using a standard ATM-based cell format that can interface to both integrated Services local and metropolitan networks. The P1357 goal requires the defining of the logical layer protocol, management, and diagnostic interfaces such that operational systems can be configured from hardware and software modules developed by different vendors. The envisioned applications for this bus protocol and associated packaging architecture will include ATM cell based LAN/MAN access and switching protocols and BISDN network access.

### 3.2.3 IEEE P1356

The mission statement for the P1356 ATM Platform Profile Working Group is to provide a standard backplane architecture using the P1357 ATM Platform protocol to integrate End user service applications into ATM networks. This new Application Environment Profile standard could use existing parallel bus architectures, e.g. FutureBus+, IEEE 896.1 or point to point architectures, e.g. the P1355 (HIC) or entirely new backplane architecture. Implementation for the End User market does not have to be at the high

bandwidth interfaces commonly associated with the ATM technology used in the public switched networks. The work of this group will depend on the results of the P1357 working group.

### 3.2.4 IEEE P896.11

P896.11 standard will define the application of I/O pins on the FutureBus+ 'E' connectors for links conforming to the standard currently under development within the IEEE P1355, and, by reference to P1355, the electrical and logical properties of the links, thus defining a "P1355 enhanced slot". This standard will also define the pins to be used on the FutureBus+ connector for P1355 links for interfacing to routing boards, thus defining a "routing board slot". The standard will define connectivity of P1355 enhanced slots and routing board slots (where provided). With this exception, the architecture of P1355 links on the back panel and the architecture of P1355 links on routing boards will be left open.

The purpose of the standard is to provide point-to-point bandwidth for interworking FutureBus+ cards from different originators by using P1355 links in addition to the bandwidth available from the standard FutureBus+ interface.

### 3.3 IEEE BASC Meeting at Durham North Carolina

IEEE BASC 1994 October meeting was held at Omni Durham Hotel in Durham, North Carolina from October 17th to 21th, 1994. During this standards meeting, this project team participated in the IEEE P1357 ATM Platform Protocol Working Group meeting, IEEE P1356 ATM Platform Profile Working Group meeting, IEEE P1355 ATM HIC Working Group meeting and IEEE P896.11 HIC of FutureBus+ backplane Working Group meeting. Because this is the first participation of the IEEE BASC meeting for this project team, we tried to participate as many as working groups possible and get as many as general meeting information possible. The details of each working group meeting are described below.

#### 3.3.1 IEEE P1355 Working Group Meeting

This was the tenth meeting of the IEEE P1355 Working Group and held on the 19th October. The chairman of this meeting was Dr. Colin Whitby-Strevens from SGS-THOMSON of United Kingdom. The other attendants are from FCI/FCF of France, C&M Corporation of USA, Electronics and Telecommunications Research Institute of Korea, AT&T, Bull System of France, Technobox Inc. of USA, AMP Inc. of USA, NTT International Corporation of Japan, AT&T Microelectronics of USA, Texas Instruments Inc. of USA and INMOS of United Kingdom. Some important issues discussed in this meetings are as followings.

##### 3.3.1.1 Related Standards Activities

Some standards activities which are related to the IEEE P1355 are introduced by the chairman.

##### ■ ISO/IEC JTC1/SC26 WG13

There was a voting on N3020, in which some 20 countries supported the proposal and eight indicated their desire to actively participate. These countries had now been requested to identify their accredited delegates. The agreement was made in holding the joint meetings with WG13 as soon as practicable, so that the draft of the IEEE P1355 can be considered jointly by both groups.

##### ■ IEEE P1356/P1357

In these meetings, no one has volunteered to chair the proposed standard for an ATM platform based IEEE P1355, and therefore the proposed Project Authorization Requests (PAR) was not being carried

forward. There was a report that the P1356 group had decided to concentrate on the FutureBus+ approach, and that other variants should be discussed or addressed later. The numbering scheme of the platforms should be associated with the particular standard on which they are based, so the current work would be a P896.n number. The P1357 group had decided to base their work on a proposal in which the VPI of the ATM cell is replaced by an internal routing address. The remaining effort is to determine the management of this addressing scheme. There was a discussion that the P1355 technology was particularly appropriate for ATM, particularly as "active backplane" techniques can provide scalable bandwidth. There was an expression that when P1357 has reached a more developed position, then it would be appropriate to evaluate how this would map onto P896.11 (for FutureBus+) and VSO 13 (for VME).

■ VSO 13 - P1355 on VME backplane Task Group

A productive meeting had been held in Phoenix, and a first draft has been produced. A list of outstanding issues has been identified.

■ IEEE P896.11

No further meeting have taken place since the last P1355 meeting. Significant interest has been shown from a number of companies following the Press Release.

### 3.3.1.2 Patents

There was an indication that working group is required to identify all patents which might be embodied in the technology within the proposed standard, i.e. for which licenses would be necessary to allow a third party to manufacture products compliant to the proposed standard. It was questioned whether it is necessary to conduct a patent search. All working group participants are asked to identify any such technology.

A letter is required from NTT agreeing to the IEEE patent conditions. Chairman reported that he has interaction with NTT, and anticipates an appropriate letter in the near future.

### 3.3.1.3 Mezzanine (P1355 on PCI)

There was extensive discussion on whether the standard connector format would fit in the front panel aperture for the PCI mezzanine card, particularly given the standard 10 mm stand-off height of the PCI card, which is set by the connector on the host card. They agreed to seek advice on this from Harting and Force Inc. After some discussion, it was concluded that it would be appropriate to define pinouts for the PCI mezzanine, and it was agreed that this should be carried out within the VSO meetings, where there is interest from several potential users.

### 3.3.1.4 Standardization of HS-SE and DS-DE connectors

The working group discussed about the matter that the use of a fixing screw prevents the HS connector from being used on VME as it makes it too high. A response from Harting indicated that it is merely a matter of new drawings to revert to the latched connector style. After extensive discussion, it was agreed to specify the latched connector style, particularly in view of the consideration that VME front panel fixings would form the largest market. However, the working group agreed that it is still desirable for high end professional applications to allow the use of a screw fixing, and to consider further whether to include the screw fixing style as an alternative.

There was a report that the HS-SE and DS-DE standardization activities in ISO/IEC was very slow. They indicated that it would take several years to finalize the standardization, and that the best that could be hoped for is that the secretariat issue the relevant document number to allow the cross reference.

### 3.3.1.5 MU connector format

The working group reviewed a fax from Thomson LCR and a paper tabled by NTT. It was considered not sufficiently important to oblige developers to incur the extra cost of developing a 12mm format,

particularly as the 14mm format is likely to be widely used. However, it was considered important to keep the size as small as possible, which mitigates against the even larger format which would accept integral transceivers. It was agreed that the 14mm proposal from NTT should be incorporated into the next draft, but that the issue of connector format be considered as an open item, with a final decision to be taken at the Milan meeting.

#### 3.3.1.6 Optical encoding

The action to prepare a recommendation on whether to continue with the TS encoding, or adopt a different encoding, is still open.

#### 3.3.1.7 Conformance

They prepared text identifying proposed subsets to which conformance could be claimed. All working group members were requested to review the proposed subsets.

### 3.3.2 IEEE P1357 Working Group Meeting

This IEEE P1357 Working Group meeting was held on the 17th October. The acting chairman of this meeting was Mr. Ed Baulsir from Design Systems, Inc. of USA. The other attendants are from CTS Corp. of United Kingdom, Framatome Connectors International, nanotek, ABB Industrial Systems, Motorola, ETRI of Korea, Technobox, Texas Instrument and INMOS Ltd. of United Kingdom. Some important issues discussed in this meetings are as followings.

#### 3.3.2.1 Related Standards Activities

Some standards activities which are related to the IEEE P1357 were introduced by the acting chairman. He stated that there is continuing interest in the application of the ATM cell with a local address capability for both the FutureBus+ (IEEE 896) and the Heterogeneous InterConnect (IEEE P1355). The chairman of the IEEE P1355, Dr. Colin Whitby-Strevens indicated that his resources at the present time does not allow him to actively participate in the Profile Standard Development. If this situation changes in the future he would initiate the appropriate request. There was an indication that some significant interest is to merge the ATM local addressing protocol with the FutureBus+ Protocol and use the A, B, C, D and X connectors on the existing FutureBus+ backplane. Some questions were raised about the need for any other new bus, as all the technology development for the FutureBus+ backplane has been done. It was pointed out that the premise for the P1357 standard was to provide an ATM Platform that is applicable to a major market segment. This market needed an Open Standard that would provide a low cost platform to merge existing services with ATM. The need for new PAR's may now be unnecessary. All work on generating these PAR's as discuss in the Minneapolis meeting has been terminated.

#### 3.3.2.2 Proposal for Cell Addressing

In the Munich and Minneapolis meetings, there were two approaches in the Cell Addressing. They are:

- To add the additional Bytes to the ATM 5 Byte header proposed by G. Nelson/E. Baulsir
- To leave the ATM header intact and use the VPI/VCI information for the local addressing function proposed by Emil Hahn, of Motorola.

Emil Hahn suggested the second technique would not increase the latency of the connection. The obvious benefit of the proposal is the retention of the existing ATM chipsets and software. The proposal outlines the reading of the VCI/VPI's and the mapping of those addresses against at management resource that would have the ability of reading 256 local addresses. After much discussion the working group voted on accepting this technique to be used in the standard. Much work still needs to be done as outlined in the contribution and volunteers are requested to bring their ideas for the management scheme to be used for the addressing.

### 3.3.2.3 Arbitration

The beauty of using the FutureBus+ is that problem has been solved. By using elements of the FutureBus+ protocol we would be able to take advantage of the existing technologies.

### 3.3.3 IEEE P1356 Working Group Meeting

This IEEE P1356 Working Group meeting was held on the 18th October. The acting chairman of this meeting was Mr. Ed Baulsir from Design Systems, Inc. of USA. The other attendants are from CTS Corp. of United Kingdom, AMP Inc., Molex, Berg Electronics, Framatome Connectors International, nanotek, Motorola, ETRI of Korea, Technobox, and INMOS Ltd. of United Kingdom. Some important issues discussed in this meetings are as followings.

#### 3.3.3.1 ATM Bus

There was a suggestion that we identify the bus we were working on it. Previously we had called it Local Address Switching Bus, LASB, but the decision was made to refer to this bus simply as; ATM Bus. There was agreement on the combining of the ATM Bus using the P1357 protocol with the FB+ Protocol IEEE 896. This means that the connector for this backplane will be the 2.0 mm Metal connector currently in use. There was a suggestion that we could provide a 64 bit bus with a clock speed of 38.88 Mbps and still use the BTL Transceivers from FutureBus+. For the ATM Bus, this would provide a bandwidth throughput of 2.48 Gbps.

#### 3.3.3.2 Physical Architecture

It was commented that there are similarities in the intended market for the ATM Platform and the FutureBus+ Telecom Profile P896.6 which is in final voting by the BASC. It was agreed that we should not re-invent the wheel and if there are applicable requirements of the Telecom Profile they should be included by using pointer in the new ATM Bus/FB+ profile standard. The overall generic platform size reflects a metric application of some of the telecom requirements for size; e.g. 300 mm max depth and 18 SU overall height. This envelope size includes power supplies and terminal management equipment. The plug-in Unit concept includes the requirement for Input/Output cabling to be attached on the front panel. This is different from the FutureBus+ backplane which has the I/O's on the backplane.

### 3.3.4 IEEE P896.11 Working Group Meeting

This IEEE 896.11 Working Group meeting was held on the 20th October 1994. The chairman of this meeting was Dr. Colin Whitby-Strevens from SGS-THOMSON of United Kingdom. Some important issues discussed in this meetings are as followings.

#### 3.3.4.1 Chairman's Report

Chairman reported that a number of contacts had been made with interested parties as a result of the press release, and the roster increased accordingly. The new work item, ISO/IEC JTC1 N3020 which seeks to standardize within ISO/IEC the IEEE P1355 specification had been approved, with some 20 countries voting in favor, and 8 indicating their desire to actively participate. It had been agreed at the previous day's IEEE P1355 meeting that future meetings of P1355 would be held jointly with ISO/IEC JTC1/SC26 WG13, in order to expedite the ISO/IEC agreement of the standard.

Chairman reported that good progress has been made at the VSO meeting in Phoenix, Arizona, in September. He distributed copies of the presentation of the status made at that meeting, and copies of the first draft. He drew attention to the fact that the presentation identified a number of open issues, which may also be of concern to P896.11. Both groups (VSO and P896.11) have agreed to keep in close contact with each other. The next meeting is scheduled for November 16-18 in Phoenix.

#### 3.3.4.2 Location of Router Board slots

There was a proposal that the basic set includes both DS and HS links. This recommendation arises from studies of two ATM applications. The questions were arisen regarding whether the signal integrity for HS links would be sufficient using the adjacent placement of HS links and the relatively small number of grounds in the current proposal. There was another indication that a pinout in which each HS signal was, as nearly as possible "surrounded" by grounds, in a pseudo-coax configuration, was preferable.

#### 3.3.4.3 Open Issues

The following remain open issues:

- Do we track P1355, P1356 and P1357?
- Does an electrical specification go in here or P1355
- Do we tailor the functionality to P1356 and ATM call set up and tear down, or is it independent?

### 3.4 IEEE BASC Meeting at Denver Colorado

1995 January IEEE BASC meeting was held at Stouffer Concourse Hotel at Denver Colorado from January 16th to 19th, 1995 in conjunction with IEEE BASC meeting. During this standards meeting, this project team participated in the IEEE P1357 ATM Platform Protocol Working Group meeting, IEEE P1356 ATM Platform Profile Working Group meeting, IEEE P1355 ATM HIC Working Group meeting and IEEE P896.11 HIC of FutureBus+ backplane Working Group meeting. The details of each working group meeting are described below.

#### 3.4.1 IEEE P1355 Working Group Meeting

The second joint meeting of the IEEE P1355 Working Group and the ISO/IEC JTC1 SC26 WG13 was held on the 19th January 1995. The chairman of this meeting was Dr. Colin Whitby-Strevens from SGS-THOMSON of United Kingdom. The other attendants are from FCI/FCF of France, NSWC, C&M Corporation of USA, Electronics and Telecommunications Research Institute of Korea, ABB Industrial Systems, AMP Inc. of USA, NTT International Corporation of Japan and Cable Design Technologies of USA. Some important issues discussed in this meetings are as followings.

##### 3.4.1.1 Related Standard Activities

Regarding the IEEE P1355.1 (low cost 50 Mbps links on UTP) meeting, the chairman reported that NESCOM had approved the PAR agreed at the Durham meeting, and that a good kick-off meeting of the new WG had been held earlier in the week. The WG considering potential applications and requirements, and had agreed to meet again in Monterey with BASC meeting.

Regarding the IEEE P1356/7 ATM Platform meeting, the chairman reported that the P1356 activity had decided at its meeting two days beforehand to generalize, and to concentrate on optimizing the FutureBus+ backplane protocols for packet-based communications. The P1357 WG on the previous day had addressed issues of the management of an ATM Platform.

Chairman reported that VITA 13-199n (P1355 links on VME) was now gathering reactions and comments from its members on the current proposals. He also reported that interest in the use of P1355, and now P1355.1, for consumer Digital Video remains high. The competitive proposals include ATM for the house wiring, and P1394 for the cluster. The EIA R4.1 has issued a request for proposals for digital interfaces for consumer digital video, and it is intended to make a submission. The deadline is February 2nd. Significant interest is being shown by several consumer electronics companies.

#### 3.4.1.2 Call for Patents

Chairman indicated that it is required that the WG identify all patents which might be embodied in the technology within the proposed standard, i.e. for which licences would be necessary to allow a third party to manufacture products compliant to the proposed standard. Such patents have already been identified with respect to the SGS-THOMSON DS-Link technology and the NTT optical connector technology.

#### 3.4.1.3 Draft D1.3 Review

Chairman indicated that he suggested the meeting review the draft and the comments received, and then consider the position with respect to Sponsor Ballot. Copies of the new draft, D1.3, dated 12th January 1995, had been made available on the ftp server, and couriered to those who had requested the service. Copies had also been couriered to Philip Longhurst (chairman of IEC SC86B WG6) and to Mary-Lynne Nielsen (IEEE staff editor).

After considerable review of the issues and discussion, it was decided to specify that DS-DE cables shall have either eight or ten conductors. It was also agreed to re-specify the skew budget for Table 5.17 for 200 Mbps. The opinion was strongly expressed that cable shield should be terminated to signal ground, however, it was agreed to make no change until the completion of the CERN experiments. The WG also decided to accept the proposed text, on the basis that the environmental conditions are application and system specific. It was agreed to include a table specifying launch power and sensitivity, as proposed by Sylvain Paineau.

#### 3.4.1.4 Proposal to submit to sponsor ballot/CD

Chairman introduced this agenda motion, indicating that he viewed the role of sponsor ballot to be that the WG considered the draft to be sufficiently solid for it to be considered in detail by the wider community. He indicated that it is likely that a number of comments would be received, and that the ballot review committee would propose changes, resulting in a recirculation ballot. It is also very possible that sufficiently substantial issues are raised that further meeting(s) of the WG have to be called to resolve these issues. The motion "the editor be instructed to make the changes agreed in the meeting, and to submit the resulting draft to IEEE for sponsor Ballot" was passed. And the same draft will also be submitted as a Committee Draft through ISO/IEC JTC1. No future meeting of IEEE P1355 is planned.

#### 3.4.2 IEEE P1357 Working Group Meeting

This IEEE P1357 Working Group meeting was held on the 18th January, 1995. Mr. Emil Hahn of the Nanotek Inc. chaired the meeting instead of the acting chairman of this meeting, Mr. Ed Baulsir from Design Systems, Inc. of USA. The other attendants are from SGS-THOMSON of United Kingdom, CTS Corp. of United Kingdom, Framatome Connectors International, nanotek, AMP Inc., Motorola, ETRI of Korea, Technobox and Texas Instrument. Some important issues discussed in this meetings are as followings.

##### 3.4.2.1 P1357 Draft 0.04

There were discussions to finalize the P1357 Draft 0.04. They decided the system architecture which includes the system management and diagnostics. They defined the ATM Interface Unit (AIU) and ATM Management Unit (AMU) and agreed to send this draft to the all members after some additional editing job by the editor.

##### 3.4.2.2 ATM Management

They discussed about the ATM Management functions of the system. They decided that the signaling information exchange are needed between the AIU and AMU.



#### 3.4.3 IEEE P1356 Working Group Meeting

This IEEE P1356 Working Group meeting was held on the 17th January, 1995. Mr. Joe George, president of the Nanotek Inc. chaired the meeting instead of the acting chairman of this meeting, Mr. Ed Baulsir from Design Systems, Inc. of USA. The other attendants are from SGS-THOMSON of United Kingdom, Motorola, Nanotek Inc., AMP Inc., ETRI of Korea and Texas Instrument. Some important issues discussed in this meetings are as followings.

##### 3.4.3.1 Organization of the Working Group

They discussed the necessity of dividing this working group into 3 sub groups depends on the related bus architecture which are HIC, FutureBus+ and ATM Bus. The decision was made to continue the FutureBus+ related job within the P896.X sub working group. And they decided to suspend the standardization activities related to the HIC and ATM Bus until P1357 standard is finalized.

##### 3.4.3.2 Physical Architecture Definition

They discussed the details of the System Enclosure, Backplane and Plug-in Unit for the ATM/IPP Protocol over the FutureBus+. The main concern was the interoperability between the FutureBus+ and VME bus.

#### 3.4.4 IEEE P896.11 Working Group Meeting

The fourth meeting of the IEEE 896.11 Working Group was held on the 19th January of 1995. The chairman of this meeting was Dr. Colin Whitby-Stevens from SGS-THOMSON of United Kingdom. The other attendants are from Nanotek Inc., AMP Inc., Motorola, ETRI of Korea and Texas Instrument. We discussed on the contents of the P896.11 Draft 1.0. However, the activities of this working group was inactive because of the lack of the attendance and editor.

## **4. ATM Forum Standardization Activities**

### **4.1 Introduction of ATM Forum**

#### **4.1.1. ATM Forum History<sup>(22)</sup>**

The ATM Forum was founded in October, 1991 by four companies: Northern Telecom, Sprint, SUN Microsystems and Digital Equipment Corporation (DEC). In January 1992, the membership was opened to the industry. There are currently three categories of membership: principal, auditing and user. Only principal members can participate in technical and marketing committee meetings. Auditing members receive copies of the technical and marketing committee documents, but can not participate in the meetings. Only user members may participate in End User Roundtable (ENR) meetings. The End User Roundtable (ENR) user group was formed in August 1993, with the goal to collect higher level requirements and provide these to the technical and MA&E committees.

#### **4.1.2. ATM Forum Organization**

There are three types of committees in the ATM Forum; technical, market awareness, and end user. The technical committee produces implementation specifications and is organized into a number of technical "subject matter expert" subcommittees. The Market Awareness and Education (MA&E) committee produces tutorials, presentations, press release, newsletters, and other informative material. There are branches of this committee in North America, Europe and Asia. The End User Roundtable (ENR) user group has the goal to collect higher level requirements and provide these to the technical and MA&E committees. The technical committee include the following working groups;

- Broadband ICI WG
- LAN Emulation WG
- Network Management WG
- Physical Layer WG
- Private NNI WG
- Service Aspects and Applications WG
- Signaling WG
- Testing WG
- Traffic Management WG
- Multi Protocol Over ATM WG

Among above working groups of the ATM technical committee, this project team participated in the LAN Emulation working group and Multi Protocol Over ATM working group.

#### **4.1.3. LAN Emulation Working Group**

In this working group, LAN Emulation Over ATM Specification is standardized. Many users view ATM as a unifying technology that will allow seamless internetworking of the older, so-called legacy LAN systems (i.e., Ethernet, Token Ring, and even FDDI) with the latest, high-performance ATM technology. This will offer a competing technology with LAN Emulation Over ATM.

LAN Emulation enables the implementation of emulated LANs over an ATM network and provides for all existing LAN applications to run over ATM. Each emulated LAN is composed of a set of LAN Emulation Clients (LE Clients) and a single LAN Emulation Service (LE Service).

#### 4.1.4 Multi Protocol Over ATM Working Group

In this working group, Multi Protocol Over ATM (MPOA) Specification is standardized. MPOA is an effort taking place in the ATM Forum to standardize protocols for the purpose of running multiple Network Layer Protocols over ATM. This working group was organized in November 1994 and is now working for the set-up of the first phase specification.

## 4.2 ATM Forum Meeting at Denver Colorado

ATM Forum 1995 April meeting was held at Stouffer Concourse Hotel in Denver Colorado from April 9th to 14th. During this standards meeting, this project team participated in the LAN Emulation Working Group meeting and Multi Protocol Over ATM Working Group meeting. The details of each working group meeting are described below.

### 4.2.1. LAN Emulation Working Group

The LAN Emulation working group meeting was held on the April 10th to 14th, 1995. About 70 people attended this meeting from all over the world. Some important issues discussed in this meetings are as followings.

#### 4.2.1.1 Future scope and requirements of the LANE

There was detailed discussions about the next version of the LUNI specification. Another discussion was about the LNNI Phase 1 specification to enable the distribution of the LE Service on the ATM network. Some baseline scope and requirements are decided.

#### 4.2.1.2 Models for LANE Server-Server Implementation

Various kinds of topology of the Distributed LAN Emulation server components were discussed. The proposals from Bay Network Inc. was adopted.

#### 4.2.1.3 MIB Scopes and Requirements for ATM LAN Emulation Servers

The scope and requirement of the Management Information Base (MIB) within the ATM LAN Emulation Services (LECS), LAN Emulation Servers (LES) and Broadcast and Unknown Servers (BUS) were discussed. This MIB was based on the LUNI 1.0 and LNNI phase 1 reference model.

#### 4.2.1.4 LAN Emulation and MPOA

There should be a pre defined rules between the LAN Emulation and MPOA because they resides on the same ATM physical fabric. Therefore, there was a discussion about the concepts and facilities of the LAN Emulation which may be adopted to the MPOA baseline model.

#### 4.2.1.5 LAN Emulation and FDDI

Current LAN Emulation is based on the Token Ring and Ethernet. There was a discussion on creating the FDDI based LAN Emulation. We decided to create the FDDI based LAN Emulation and agreed to continue this discussion.

### 4.2.2 Multi Protocol Over ATM Working Group

The Multi Protocol Over ATM (MPOA) working group meeting was held on the April 10th to 14th, 1995. About 100 people attended this meeting from all over the world. Some important issues discussed in this meetings are as followings.

#### 4.2.2.1 Scope and Requirement

There was discussions about the scope, requirement and reference model of the MPOA Working Group.

#### 4.2.2.2 Logical Model of the MPOA

Defining the logical model of the MPOA is the first step to make the common background which enables the co-work on the MPOA. The logical model proposed by the Newbridge Network Corporation was discussed and agreed.

#### 4.2.2.3 Administrative Scopes in MPOA

There was discussions about the administration scope of the MPOA. Protocols, virtual subnetwork scopes, MPOA system scope and ATM network scopes are the required administration scopes of the MPOA. Their functions and relationships are defined.

## **5. Conclusion.**

This document describes the standardization activities which were performed during the first year period of the joint project called "A Standardization and Research Project on an ATM/B-ISDN Switching Fabric System" that is being jointly performed by Protocol Engineering Center (PEC) of Electronics and Telecommunications Research Institute (ETRI), Institute for System Research (ISR) of the University of Maryland at College Park (UMCP) and Modacom Co., Ltd. This document also provides the general information about the IEEE Standards meetings and ATM Forum Standards meetings.

The main goal of this joint product is to design the ATM LAN Access Switch (ALAX) whose function is to provide the interface between legacy LAN and ATM world. To provide this functionality, we need to implement the LAN Emulation protocol or Multi Protocol over ATM (MPOA) protocol into the ALAX system. The LAN Emulation protocol is now on the standardization procedure at the LAN Emulation SWG Drafting Group of the ATM Forum Technical Meeting Committee. The MPOA protocol is also on the standardization procedure at the Multiprotocol Sub-Working Group of the ATM Forum Technical Meeting Committee. Therefore, we participated in the ATM Forum meeting to apply the results of the ATM Forum into the ALAX system design.

Another important design characteristics of the ALAX is the adoption of the IEEE P1355 Standard for Heterogeneous Inter Connect(HIC) as the data communication paths within the ALAX switching system. This makes it possible for this project team to design the PC-based parallel architected high performance switching system in conformance with emerging open technologies and related standards. The standardization activities related to the IEEE P1355 are performed at the IEEE BASC standard meetings and we participated in this meetings two times. The standardization activities will be performed by this project team in order to contribute the protocol design results of the ALAX system to the P1357 Working Group of the IEEE Bus Architecture Standards Committee.

Many research works are under way from many research institutes regarding the high-performance system for the ATM network and its new applications for the ATM network<sup>[23][24][25]</sup>. In our joint project, we expect to expand our research areas to many of the new ATM network service applications. To make them possible, many interfaces to the proper applications and networks will be needed. At the same time, in the near future, we will contribute to these standards meetings by submitting the protocol standards which will be developed during the designing process of ALAX system. By doing these standardization activities, we can achieve the goal of this project which are the development of the leading edge products and the accomplishments of the advanced standardization activities. And this standardization activities can be the good model case for the advanced standardization research efforts in the Protocol Engineering Center (PEC) of Electronics and Telecommunications Research Institute (ETRI) of Korea.

## **REFERENCES**

- [1] Jangkyung Kim, Man Geun Ryu "ATM LAN Access Switch (ALAX): Protocol Architecture (LAN Emulation Version)", June 1995
- [2] Man Geun Ryu, Jangkyung Kim, "ATM LAN Access Switch (ALAX): System Architecture", May 1995
- [3] PCI Special Interest Group, "PCI Local Bus Specification, Revision 2.0", April, 1993.
- [4] PCI Special Interest Group, "PCI Multimedia Design Guide, Revision 1.0", March, 1994.
- [5] PCI Special Interest Group, "PCI BIOS Specification, Revision 2.1", August, 1994.
- [6] PCI Special Interest Group, "PCI to PCI Bridge Architecture Specification, Revision 1.0", April, 1994.
- [7] IEEE, "IEEE Draft Std P1355, Standard for Heterogeneous InterConnect (HIC) (Low Cost Low Latency Scalable Serial Interconnect for Parallel System Construction)", January 1995
- [8] de Prycker, "Asynchronous Transfer Mode, Second Edition", Ellis Horwood, 1993
- [9] Byeong Gi Lee, Minho Kang & Jonghee Lee, "Broadband Telecommunications Technology", Artech House, 1993
- [10] David E. McDysan, Darren L. Spohn, "ATM theory and application", McGraw-Hill, Inc., 1995
- [11] ATM Forum, "ATM User-Network Interface Specification, version 3.0", PTR Prentice Hall, 1993
- [12] William Stallings, "SNMP, SNMPv2, and CMIP, The Practical Guide to Network Management Standards", Addison-Wesley Publishing Company, 1993.
- [13] IEEE, "Carrier Sense Multiple Access with Collision Detection (CSMA/CD) Access Method and Physical Layer Specifications", American National Standard ANSI/IEEE Std. 802.3, 1985
- [14] William Stallings, "Handbook of Computer Communications Standards - Local Network Standards", Macmillan Publishing Company, 1987
- [15] LAN Emulation SWG Drafting Group, "ATM Forum/94-0035R7, LAN Emulation Over ATM Specification - Version 0", ATM Forum, December 1994
- [16] Kaman Sciences Corporation, "VINCE 1.0: Application Programmers Interface (API) manual", Naval Research Laboratory, January 1995
- [17] Paul Mc Galey, Donal O'Mahony, "Developing an ATM Video Transfer Service in a VINCE Environment", Networks and Telecommunication Research Group, Department of Computer Science, Trinity College Dublin, January 1995
- [18] Eric Hoffman, " Protocol Stack Implementation in VINCE", University of Southern California, Information Sciences Institute, March 1995
- [19] The Institute of Electrical and Electronics Engineers Inc., "IEEE Standard Board, Bylaws", December 1993
- [20] The Institute of Electrical and Electronics Engineers Inc., "IEEE Standards, Operational Manual", January 1994
- [21] IEEE, "P1357 Standard for Logical Interconnection of Multi-Protocol Plug-In Modules Supporting Asynchronous Transfer Mode (ATM)", October 1994
- [22] David E. McDysan, " ATM, Theory and Application", McGraw-Hill Inc. NewYork, 1995
- [23] Jerome R. Cox, Jr., Michale E. Gaddis & Jonathan S. Turner, "Project Zeus", IEEE Network, March 1993
- [24] Jonathan M. Smith & C. Brendam S. Traw, "Giving Applications Access to Gb/s Networking", IEEE Network, July 1993
- [25] Edoardo Biagioni, Eric Cooper, & Robert Sansom, "Designing a Practical ATM LAN", IEEE Network, March 1993