

University of Texas Rio Grande Valley

ScholarWorks @ UTRGV

Mechanical Engineering Faculty Publications
and Presentations

College of Engineering and Computer Science

6-10-2016

Temperature Profiles of Railroad Tapered Roller Bearings With Defective Inner and Outer Rings

Constantine Tarawneh

The University of Texas Rio Grande Valley, constantine.tarawneh@utrgv.edu

Luz Sotelo

The University of Texas Rio Grande Valley

Anthony A. Villarreal

The University of Texas Rio Grande Valley

Nancy de los Santos

The University of Texas Rio Grande Valley

Ryan L. Lechtenberg

The University of Texas Rio Grande Valley

See next page for additional authors

Follow this and additional works at: https://scholarworks.utrgv.edu/me_fac



Part of the [Mechanical Engineering Commons](#)

Recommended Citation

Tarawneh, CM, Sotelo, L, Villarreal, AA, de los Santos, N, Lechtenberg, RL, & Jones, R. "Temperature Profiles of Railroad Tapered Roller Bearings With Defective Inner and Outer Rings." Proceedings of the 2016 Joint Rail Conference. 2016 Joint Rail Conference. Columbia, South Carolina, USA. April 12–15, 2016. V001T06A018. ASME. <https://doi.org/10.1115/JRC2016-5816>

This Conference Proceeding is brought to you for free and open access by the College of Engineering and Computer Science at ScholarWorks @ UTRGV. It has been accepted for inclusion in Mechanical Engineering Faculty Publications and Presentations by an authorized administrator of ScholarWorks @ UTRGV. For more information, please contact justin.white@utrgv.edu, william.flores01@utrgv.edu.

Authors

Constantine Tarawneh, Luz Sotelo, Anthony A. Villarreal, Nancy de los Santos, Ryan L. Lechtenberg, and Robert Jones

JRC2016-5816

TEMPERATURE PROFILES OF RAILROAD TAPERED ROLLER BEARINGS WITH DEFECTIVE INNER AND OUTER RINGS

Constantine M. Tarawneh

Mechanical Engineering Dept.
The University of Texas Rio
Grande Valley
Edinburg, TX, 78539, USA

Constantine.tarawneh@utrgv.edu

Luz Sotelo

Mechanical Engineering Dept.
The University of Texas Rio
Grande Valley
Edinburg, TX, 78539, USA

Anthony A. Villarreal

Mechanical Engineering Dept.
The University of Texas Rio
Grande Valley
Edinburg, TX, 78539, USA

Nancy de los Santos

Mechanical Engineering Dept.
The University of Texas Rio
Grande Valley
Edinburg, TX, 78539, USA

Ryan L. Lechtenberg

Mechanical Engineering Dept.
The University of Texas Rio
Grande Valley
Edinburg, TX, 78539, USA

Robert Jones

Mechanical Engineering Dept.
The University of Texas Rio
Grande Valley
Edinburg, TX, 78539, USA

ABSTRACT

In the railroad industry, monitoring the condition of key components such as bearings and wheels is vital to ensure the safe transport of goods and commodities. Bearing seizures are amongst the most dangerous types of failures experienced by trains because they occur unexpectedly and may lead to costly derailments. Current bearing health monitoring techniques include tracking the temperature and acoustic emissions given by the bearings. Although temperature histories of railroad tapered roller bearings are readily available, the literature does not provide information relating the temperature profiles to the severity of the bearing defect. The study presented here investigates the correlation between temperature profiles and bearing defect severity measured by the size of spalls present on bearing outer (cup) and inner (cone) rings. The temperature data used for this study was acquired from defective and healthy bearings that were run at various operating load and speed conditions. The data presented here provides the railroad industry with a greater understanding of the thermal behavior of defective bearings, which can be used to assess the future needs of bearing condition monitoring systems.

INTRODUCTION AND BACKGROUND

Conventional bearing health monitoring systems rely on the bearing outer ring (cup) temperature emissions detected by wayside infrared devices known as hot-box detectors (HBDs). HBDs take a snapshot of the bearing temperature at designated

wayside detection sites which, depending on the track, may be spaced as far apart as 65 km (~40 mi). If a bearing is found to be operating at temperatures greater than 94.4°C (170°F) above ambient conditions, the HBD will trigger an alarm and the suspect bearing will be removed from service for later disassembly and inspection.

An extension of this practice is the tracking of bearing temperatures and comparing each bearing temperature to the average temperature of all the bearings on the same side of the train. Bearings running at temperatures higher than the average, as detected by multiple HBDs, are said to be “warm trending” and are flagged without the HBD being triggered [1]. Bearings that are identified in this manner are removed from service for later disassembly and inspection. In most cases, the cause of bearing overheating may be attributed to one of several modes of bearing failure such as spalling, water contamination, loose bearings, broken components, damaged seals, incorrect mounting procedures, etc. However, there have been several documented cases where the bearings removed do not exhibit evidence of any of the common causes of bearing failure. These latter bearings are classified as “non-verified” bearings. According to data collected by Amsted Rail from 2001 to 2007, an average of nearly 40% of bearing removals are *non-verified*. This figure approached 60% in 2003 and 2004, and never dropped below 24% during the period from 2001 to 2007. In other words, a considerable percentage of bearings pulled from service based on HBD readings have no discernable defects.

Researchers have placed special emphasis on this warm trending phenomenon because it leads to unnecessary and

costly removals of non-verified bearings. As part of the efforts to understand and assess this phenomenon, laboratory testing of bearings removed from service was conducted [2], which was followed by an extensive study of the heat transfer paths between railroad components. Because both normal and problematic events (such as breaking or a wheel flat) can considerably raise the temperature of the wheel, analytical models of the heat transfer from the wheel to the bearing were devised and yielded results within 4% error of experimentally-acquired data [3]. It was also determined that the main mechanism of heat transfer between these components is conduction. Analytical models were also derived for the heat transfer paths from the rollers to the outer and inner rings, where it was concluded that fully-loaded bearing conditions result in increased surface contact and better heat transfer. These derived models produced results within less than 7% error [4]. Thorough inspection of some of the non-verified bearings revealed a distinct discoloration of some of the rollers. This discoloration was reproduced by holding rollers immersed in a grease bath at 232°C (450°F) for at least 4 hours [5]. Thus, finite element models of the heat transfer between bearing rollers and outer and inner rings were developed. The results of these models suggest that rollers in normal operating conditions are only 5°C (9°F) hotter than the bearing outer ring (cup). However, abnormal operating conditions such as those produced by misaligned rollers can result in significantly higher roller temperatures (thus producing the distinct discoloration mentioned earlier) without heating the bearing cup to levels that will trigger a HBD alert [6]. Finally, the path of heat transfer from the bearing outer ring to the adapter was quantified experimentally and using finite element models, with the motivation of developing an onboard bearing health monitoring system as opposed to relying on wayside detection systems [7].

The thermally-induced failures caused by unstable thermal expansion internal bearing loads were modeled at high speeds and zero initial loads and pre-loads. At the highest speed of 161 km/h (100 mph), the bearings failed after 200-300 hours of operation. In addition, the highest contact pressure was found to occur at the inner race – roller contact, and the highest temperature at the rib – roller contact [8].

In general, authors have agreed on the shortcomings of the current methods of bearing health monitoring and defect detection. The discrete nature of the wayside detection systems coupled with their limited accuracy have been pointed out in the context of different modes of railroad component failure. As mentioned earlier, the warm trending phenomenon has resulted in costly removals of bearings with no discernable defects. Furthermore, thermal models have shown that even when a few rollers reach unsafe temperatures, the temperature of the outer ring may not reach levels that trigger a HBD. Bearing burn off occurs at rates too rapid to be detected by conventional wayside detection methods [1]. Finally, if the unsafe conditions persist undetected and result in bearing seizure failure, the generated frictional heating can weaken an axle in between 60 and 135 seconds [9].

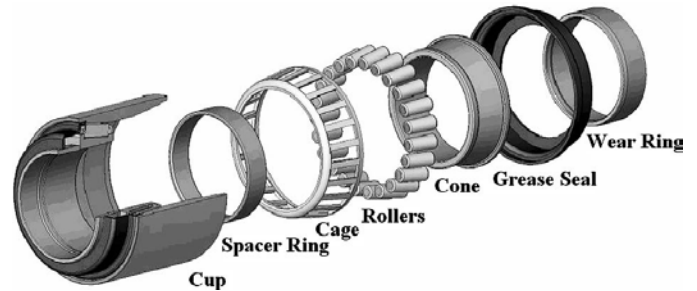

Figure 1. A detailed component view of a typical railroad tapered roller bearing assembly.

Considering all the work that has been done in this area, it seems to mostly revolve around the assumption that bearings with defects will operate at temperatures that are discernably higher than those of healthy bearings, and thus, it would be possible to distinguish between the two by monitoring their temperature. Little to no data can be found in the literature that compares the operating temperatures of defective bearings versus defect-free (healthy) bearings. This paper bridges that gap by providing experimental temperature data collected for bearings with inner and outer ring defects of varying severity as compared to healthy bearings. The strength of this paper lies in the fact that the acquired data is the result of 70 dynamic bearing tests conducted in the laboratory under varying loads, speeds, and ambient conditions.

EXPERIMENTAL SETUP AND INSTRUMENTATION

All the experiments were performed using the dynamic bearing testers at The University of Texas Rio Grande Valley (UTRGV), pictured in Figure 2. The dynamic test rig can accommodate four Class K (6 ½ × 9") or Class F (6 ½ × 12") tapered-roller bearings. Tests were performed at several different velocities, as listed in Table 1. Convective cooling was achieved with three fans that produced an air stream traveling at an average speed of 5 m/s (11.2 mph) across the bearings. The dynamic bearing testers are equipped with a hydraulic cylinder capable of applying loads ranging from 0 to 175% of full load. The data provided in this paper were acquired utilizing a 17% load setting, which simulates an empty railcar, and a 100% load setting, which simulates a fully-loaded railcar and corresponds to a load of 153,000 N (34,400 lb) per bearing.

The instrumentation setup is illustrated in Figure 3. Four bearing adapters were specially machined to accept a 500g accelerometer and two K-type bayonet thermocouples, one inboard and one outboard. To ensure the accuracy of the bayonet thermocouples, one K-type thermocouple was fixed to the middle of each bearing using a hose clamp and was aligned level with the two bayonet thermocouples. Additionally, two K-type thermocouples were used to monitor and record the ambient temperature surrounding the tester; one was positioned at the front of the tester and the other at the rear of the test rig. Data collected from fourteen thermocouples and four accelerometers were recorded utilizing a National Instruments

(NI) data acquisition system (DAQ) programmed using LabVIEW™. The NI PXIe-1062Q DAQ equipped with a NI TB-2627 card to collect temperature data from the thermocouples and an 8-channel NI PXI-4472B card to record the accelerometers were used in this study. The accelerometers were connected to the NI PXI-4472B card via a 10-32 coaxial jack and a BNC connection.



Figure 2. Photographs of the dynamic bearing testers used to conduct the experiments for this study.

Table 1. A list of the speeds used to conduct the laboratory experiments for this study.

Speed (rpm)	Speed (mph)	Speed (km/h)
140	15	24
187	20	32
234	25	40
280	30	48
327	35	56
374	40	64
420	45	72
498	53	85
560	60	97
618	66	106
699	75	121
799	85	137

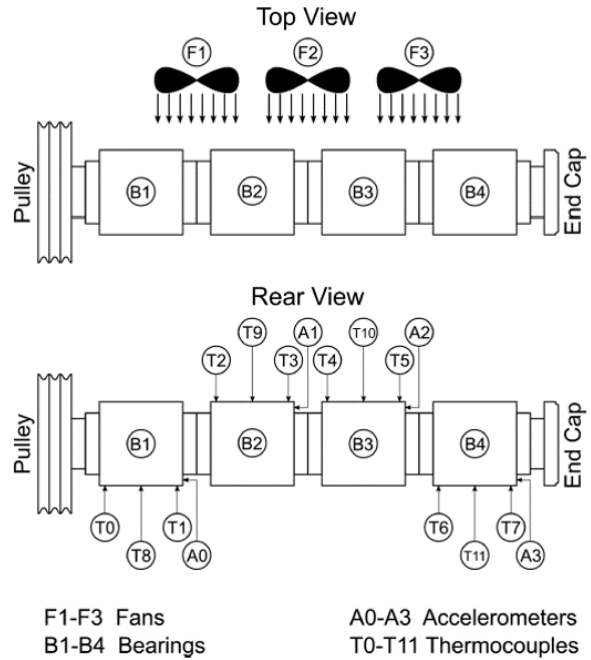

Figure 3. Schematic showing the top and rear view of the dynamic bearing tester, including sensor locations.

METHODOLOGY

The data used for this study was taken from bearings 2 and 3 because they are top loaded and best simulate field service operating conditions. A defective bearing (inner or outer ring containing a spall) and a control (defect-free) bearing were placed in either position 2 or 3 in all experiments. Bearings 1 and 4 were bottom-loaded defect-free bearings used to complete the axle setup. When outer ring (cup) defects were tested, the defect was placed in the region of maximum load (top center). Defect areas on both inner and outer rings were measured before and after each experiment in order to track any changes in the areas. The majority of the performed tests started at 40 km/h (25 mph) and 17% of full load. Once the bearings reached steady state temperature, the speed was incremented, allowing the temperature to achieve steady state conditions at each set speed. This procedure was repeated until the final speed of 137 km/h (85 mph) was reached. Once all the data was collected at 17% of full load, the load was increased to 100%, and data was acquired at all speeds starting at 137 km/h (85 mph) and stepping down in speed, again, allowing the bearing temperatures to reach steady state conditions between each set speed. Once the experiment was completed, all bearings were disassembled and carefully inspected for new defects, or changes to the existing spalls.

The temperature data of healthy (defect-free) bearings versus bearings with inner or outer ring defects acquired from a total of 70 laboratory experiments was analyzed for this study. The data analysis was performed using the mathematical software MATLAB™. The temperature data originated from the two K-type bayonet thermocouples located at each bearing

(refer to Figure 3). The statistical mean and corresponding uncertainty of the two thermocouples was calculated for every speed and load combination. The uncertainty in the temperature data was within 3°C (5°F). Finally, the data obtained was evaluated according to the defect severity as determined by its area. The approximate area of the spalls was obtained by treating the spall as a rectangle, and measuring the spall's length and width. The area of the spall was measured at the beginning and end of each experiment. The test plan was developed to populate bearing temperature profiles at speeds and loads typical of field service conditions.

RESULTS AND DISCUSSION

The main objective of this study is to compare the temperature profiles of bearings with inner and outer ring defects to those of healthy bearings. In doing so, the effectiveness of temperature monitoring as a tool to assess bearing health is evaluated. The mean ambient temperature in all the experiments performed for this study was approximately 78°F (26°C). The average operating temperatures (above ambient) of bearings with inner and outer ring defects at various speeds for 17% (empty railcar) and 100% (fully-loaded railcar) load conditions are plotted in Figure 4 and Figure 5, respectively, as compared to the average operating temperatures (linear fits with R^2 values of 0.95 and 0.99, respectively) of the healthy (control) bearings at the corresponding speed and load conditions. The average inner ring defect size for the data provided in Figure 4 is 0.77 in² (497 mm²), whereas, the average outer ring defect size for the data given in Figure 5 is 0.92 in² (594 mm²).

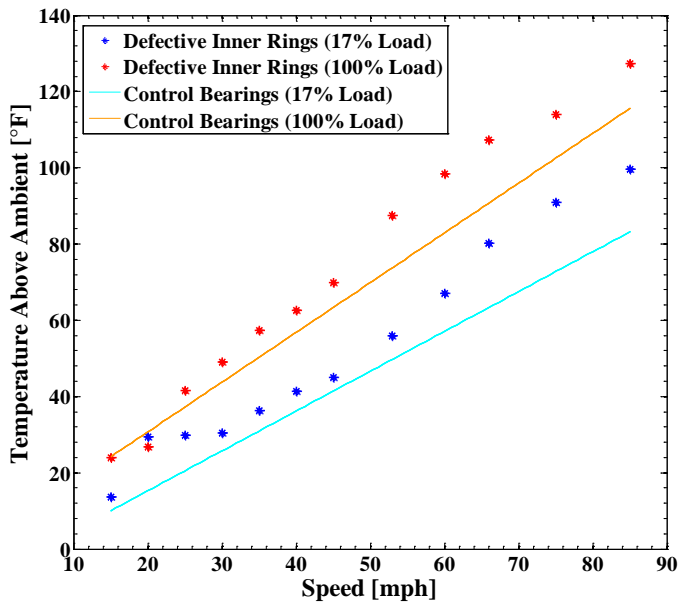

Figure 4. Average operating temperatures above ambient (78°F) of bearings with inner ring defects as compared to healthy (control) bearings at various speeds under 17% (empty railcar) and 100% (full railcar) load conditions.

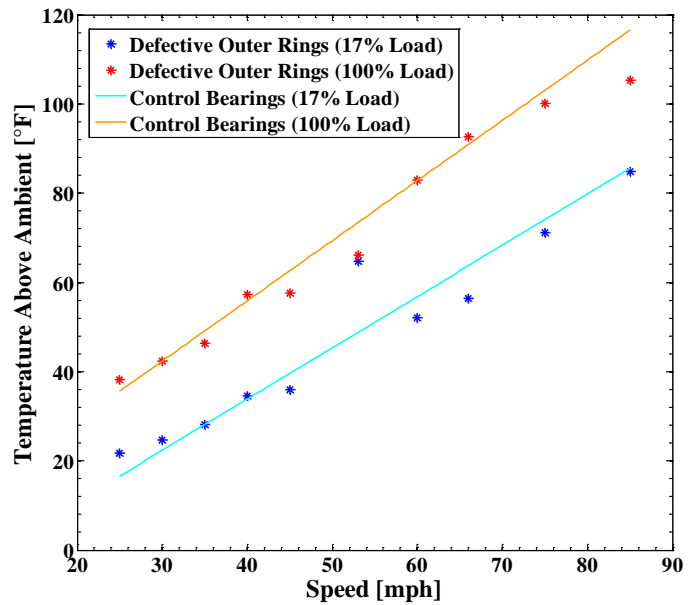

Figure 5. Average operating temperatures above ambient (78°F) of bearings with outer ring defects as compared to healthy (control) bearings at various speeds under 17% (empty railcar) and 100% (full railcar) load conditions.

From Figure 4 and Figure 5, it is evident that there is an almost linear increase in bearing operating temperature with speed. Moreover, speed seems to play a more important role on the bearing operating temperature than load. For example, going from 17% to 100% load will result in an average temperature increase of about 23°F (13°C) in a healthy bearing, whereas, going from 25 to 66 mph results in an average temperature increase of about 48°F (27°C) in a healthy bearing. Note that changes in speed will be more common in field service operation than changes in load.

In Figure 4, the average operating temperatures of the bearings with inner ring defects are mostly above the control bearings average temperature (linear fit). As speed increases, the average temperature of the bearings with inner ring defects appears to diverge from the linear fit of the control bearings; a behavior that is more pronounced in the 17% (empty railcar) load condition. On the other hand, the average operating temperatures of bearings with outer ring defects are consistently at or below the average operating temperatures of the control (healthy) bearings (linear fit) for both loading conditions, as seen in Figure 5. This difference in temperature behavior with respect to the defective bearing component can be explained by referring to the findings in the literature. It was stated earlier that the highest contact pressure during bearing operation occurs between the rollers and the inner ring (cone), and that the higher temperatures within the bearing assembly are seen at the rib – roller contact [8]. It is then expected that if a defect is present on the inner ring (cone) race, it will experience more contact with the rollers, thus, increasing the frictional heating. Moreover, the inner ring is in constant

rotational motion, hence, the likelihood of roller misalignment due to contact with the defect is much higher. If roller misalignment occurs, frictional heating is further exacerbated. The combination of the aforementioned effects tends to raise the overall bearing operating temperature which in turn decreases the viscosity of the lubricant leading to more metal-to-metal contact and added frictional heating. The latter becomes even more evident at higher operating speeds (≥ 60 mph), as demonstrated in Figure 4, where the average operating temperature of bearings with inner ring defects is about 15°F (8°C) above that of healthy bearings. One explanation as to why the behavior seen in bearings with inner ring (cone) defects is not observed in bearings with defects present on the outer ring (cup) raceways is that spalls present on the cup raceways may favor the formation of pockets of lubricant which in turn enhances lubrication and maintains the operating temperature at or below the average operating temperature of healthy bearings.

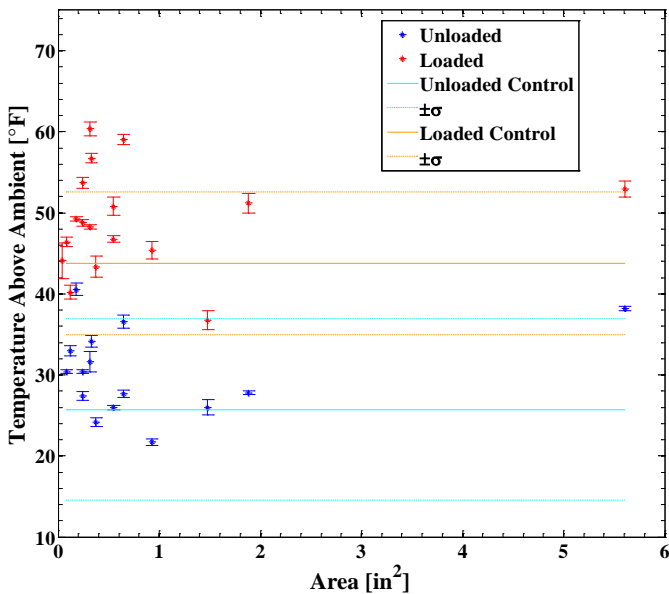

Figure 6. Temperature data of bearings with inner ring defects of various sizes (as measured by defect area) compared against the range of operating temperatures for healthy (control) bearings for unloaded (17% load) and loaded (100% load) conditions at a speed of 30 mph.

For a more detailed analysis, the temperatures obtained for bearings with different size inner and outer ring defects (as measured by the defect area) at two common operating speeds (30 and 60 mph) were plotted and compared against the range of healthy (control) bearing temperatures subjected to the same load and speed conditions. The temperature data for bearings with inner ring defects at operating speeds of 30 and 60 mph are given in Figure 6 and Figure 7, respectively, whereas, the temperature data for bearings with outer ring defects at operating speeds of 30 and 60 mph are provided in Figure 8 and Figure 9, respectively. Note that the data points plotted in

Figure 4 and Figure 5 at 30 and 60 mph for the unloaded (17% load) and loaded (100% load) conditions represent an average of all the data points seen in Figure 6 through Figure 9 for bearings with inner and outer defects of various sizes (as measured by the defect area).

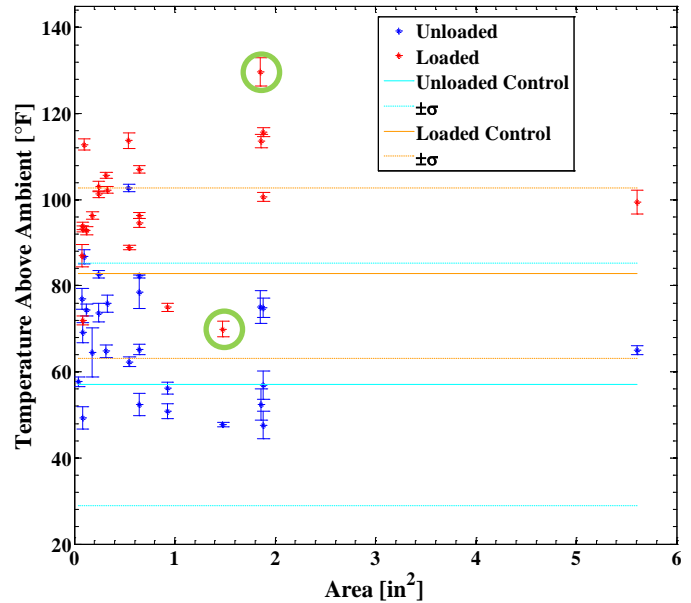

Figure 7. Temperature data of bearings with inner ring defects of various sizes (as measured by defect area) compared against the range of operating temperatures for healthy (control) bearings for unloaded (17% load) and loaded (100% load) conditions at a speed of 60 mph.

By looking at Figure 6 through Figure 9, it becomes apparent that there is no distinct correlation between defect severity and the corresponding bearing operating temperature. While a few bearings with defective inner and outer rings were found to be operating at temperatures above the control (healthy) bearing temperature range for the given speeds and loads, a significant number of bearings with defective inner and outer rings were running at temperatures within or below the healthy bearing temperature range. Therefore, temperature alone does not seem to be a good indicator of the presence of a defect within a bearing, much less of defect severity. The aforementioned statement can be validated by looking at the two data points circled in green in Figure 7. One data point belongs to a bearing with an inner ring defect size of 1.48 in^2 (955 mm^2), whereas, the other data point belongs to a bearing with an inner ring defect size of 1.88 in^2 (1213 mm^2). These two defects are pictured in Figure 10. While the bearing with larger defect size has an operating temperature that is relatively higher than the healthy bearing operating temperature range, the bearing with the slightly smaller defect has an operating temperature that is markedly lower than the operating temperature range for healthy bearings. In fact, the bearing with the inner ring defect size of 1.48 in^2 has an operating temperature that is significantly lower than that of other

bearings with much smaller inner ring defects. For this reason, the question of what other defect characteristics can affect the overall bearing operating temperature was raised.

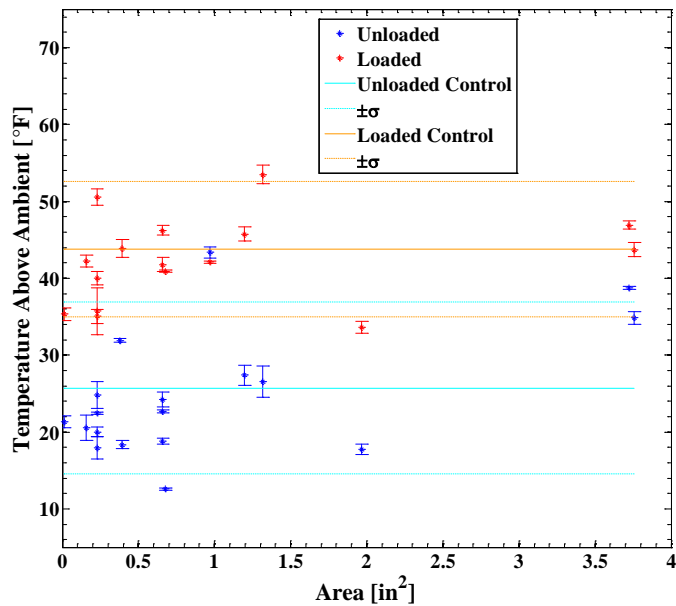

Figure 8. Temperature data of bearings with outer ring defects of various sizes (as measured by defect area) compared against the range of operating temperatures for healthy (control) bearings for unloaded (17% load) and loaded (100% load) conditions at a speed of 30 mph.

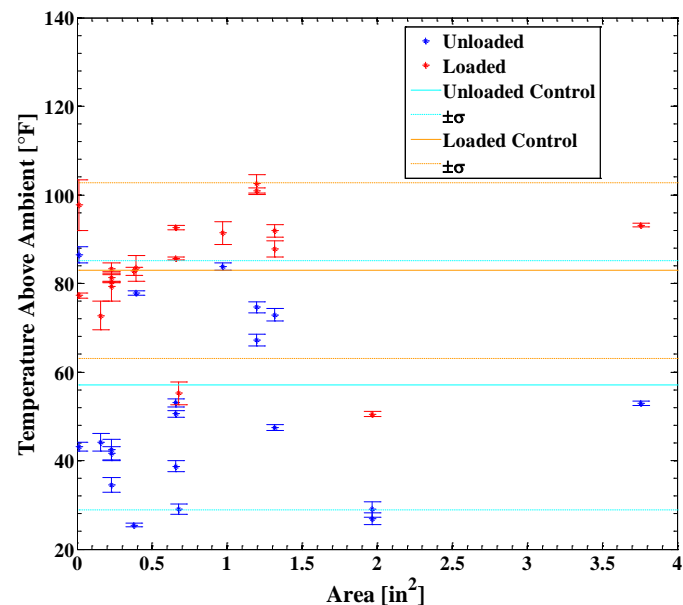

Figure 9. Temperature data of bearings with outer ring defects of various sizes (as measured by defect area) compared against the range of operating temperatures for healthy (control) bearings for unloaded (17% load) and loaded (100% load) conditions at a speed of 60 mph.

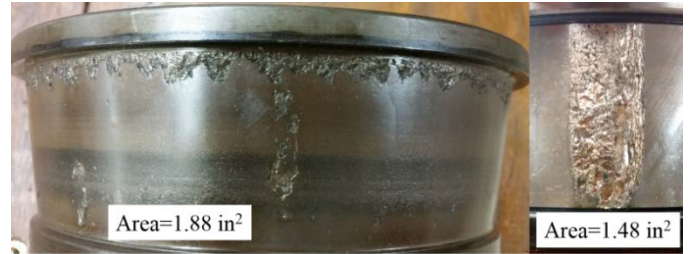

Figure 10. Photographs depicting large defects (spalls) present on bearing inner ring (cone) raceways.

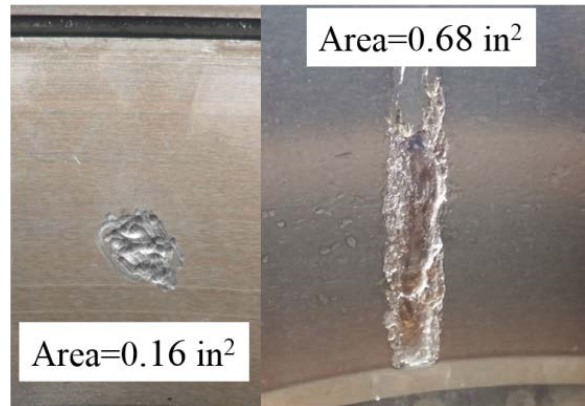

Figure 11. Photographs depicting small (left) and medium (right) size defects (spalls) present on bearing outer ring (cup) raceways.

Examining Figure 10, the reason for the large difference in operating temperature of the two defective inner rings becomes apparent. The defect on the left side of Figure 10 is spread across a narrow zone of the raceway closest to the upper cone rib, whereas, the defect on the right side of Figure 10 forms a rectangular spall that stretches across the width of the raceway. As mentioned earlier, the highest temperature within the bearing assembly is expected to occur along the roller – rib contact zone. Thus, the presence of a spall in this zone will exacerbate the frictional heating, degrade the lubricant, and significantly increase the likelihood of roller misalignment, which will result in higher bearing operating temperatures. On the other hand, it seems like when the defect (spall) stretches across the width of the raceway, such as in Figure 10 (right), the spall cavity fills with lubricant which tends to reduce the likelihood of rollers misaligning. Hence, the presence of a defect as severe as the one depicted in Figure 10 (right) will go undetected by conventional wayside HBDs because the bearing operating temperature is below that of the healthy bearing operating range, as can be seen in Figure 7. In this case, the bearing with the inner ring defect size of 1.88 in², depicted in Figure 10 (left), had an operating temperature of about 130°F (72°C) above ambient, whereas, the bearing with the inner ring defect size of 1.48 in², pictured in Figure 10 (right), had an operating temperature of about 70°F (39°C) above ambient. In comparison, the average operating temperature of a healthy

(control) bearing running at 60 mph under full load is about 83°F (46°C) above ambient conditions.

The defects in this study were classified by their size in three categories: (1) small defects (0 – 0.25 in²), (2) medium defects (0.25 – 1 in²), and (3) large defects (> 1 in²). Similarly, the speeds at which the bearings were run were classified in the following categories: (1) low speed (15 – 30 mph), (2) medium speed (30 – 55 mph), and (3) high speed (> 55 mph). Figure 10 provides examples of large defects, and Figure 11 gives examples of small and medium size defects. A summary of the average operating temperatures of bearings with inner and outer ring defects is given in Table 2 and Table 3, respectively. Looking at Table 2, it can be observed that the bearing operating temperatures rise markedly as the speed increases, similar to the results plotted in Figure 4. Interestingly, however,

the operating temperature, in many cases, tends to decrease with increasing defect size.

Examining Table 3, it can be observed that the bearing operating temperatures rise almost linearly with the speed, as exhibited in Figure 5. For bearings with outer ring (cup) defects, in most cases, the operating bearing temperature tends to increase with defect size. Furthermore, note that most of the operating temperatures for bearings with inner and outer ring defects do not greatly differ from the average operating temperatures of healthy (control) bearings at the same load and speed conditions. More importantly, none of these temperatures are high enough to trigger the HBD alarm threshold of 94.4°C (170°F) above ambient conditions set by the Association of American Railroads (AAR).

Table 2. Summary of average operating temperatures above ambient conditions (78°F) for bearings with inner ring (cone) defects

17% Load (empty/unloaded railcar)				100% Load (fully-loaded railcar)			
Speed [mph]	Spall Size [in ²]	ΔT [°C / °F]	Control ΔT [°C / °F]	Speed [mph]	Spall Size [in ²]	ΔT [°C / °F]	Control ΔT [°C / °F]
15 - 30	0 - 0.25	17.2 / 30.9	11.1 / 20.0	15 - 30	0 - 0.25	25.1 / 45.2	19.2 / 34.6
	0.25 - 1	14.3 / 25.8			0.25 - 1	19.7 / 35.5	
	> 1	15.9 / 28.6			> 1	25.0 / 44.9	
30 - 55	0 - 0.25	26.5 / 47.7	20.6 / 37.1	30 - 55	0 - 0.25	37.4 / 67.2	32.8 / 59.0
	0.25 - 1	24.2 / 43.5			0.25 - 1	39.1 / 70.4	
	> 1	22.4 / 40.4			> 1	38.8 / 69.9	
> 55	0 - 0.25	33.3 / 60.0	38.5 / 69.3	> 55	0 - 0.25	43.2 / 77.8	55.2 / 99.4
	0.25 - 1	52.0 / 93.6			0.25 - 1	65.3 / 117.6	
	> 1	44.6 / 80.3			> 1	64.8 / 116.7	

Table 3. Summary of average operating temperatures above ambient conditions (78°F) for bearings with outer ring (cup) defects

17% Load (empty/unloaded railcar)				100% Load (fully-loaded railcar)			
Speed [mph]	Spall Size [in ²]	ΔT [°C / °F]	Control ΔT [°C / °F]	Speed [mph]	Spall Size [in ²]	ΔT [°C / °F]	Control ΔT [°C / °F]
15 - 30	0 - 0.25	11.2 / 20.1	11.1 / 20.0	15 - 30	0 - 0.25	21.8 / 39.2	19.2 / 34.6
	0.25 - 1	12.5 / 22.5			0.25 - 1	22.5 / 40.5	
	> 1	15.9 / 28.7			> 1	23.0 / 41.4	
30 - 55	0 - 0.25	20.7 / 37.3	20.6 / 37.1	30 - 55	0 - 0.25	30.4 / 54.8	32.8 / 59.0
	0.25 - 1	23.8 / 42.9			0.25 - 1	30.6 / 55.2	
	> 1	23.2 / 41.8			> 1	34.4 / 61.9	
> 55	0 - 0.25	27.4 / 49.3	38.5 / 69.3	> 55	0 - 0.25	40.1 / 72.2	55.2 / 99.4
	0.25 - 1	36.2 / 65.2			0.25 - 1	51.8 / 93.3	
	> 1	37.4 / 67.3			> 1	53.1 / 95.6	

CONCLUSIONS

Conventional wayside bearing condition monitoring systems (i.e., Hot-Box Detectors - HBDs) rely heavily on temperature as the main indicator of bearing health. The major drawbacks of the current methods stem from their discrete nature, limited accuracy, and restricted scope—factors that render these systems insufficient to adequately monitor bearing health and effectively detect faulty bearings. In addition to the HBDs, acoustic measuring devices known as the Trackside Acoustic Detection System (TADS[®]) have been used in the field to identify defective bearings. The success rate of capturing a defective bearing is heavily based on the severity of the defect. Bearings with large defects, known as “growlers”, have a much higher rate of being recognized as opposed to bearings with smaller defects. Although nearly five thousand HBDs are currently in service, only fifteen TADS[®] have been implemented in North America [10], which means a train can run thousands of miles before encountering an acoustic bearing detector. Furthermore, the majority of warm trended bearings are found to be defect-free (i.e., non-verified bearings), which results in waste of resources, both in finances and manpower.

This paper evaluates the operating temperatures of bearings with inner (cone) and outer (cup) ring defects from 70 experiments as compared to the operating temperature range of healthy bearings. No distinct correlations were found between defect severity, as measured by the defect area, and operating temperatures of bearings with inner and outer ring defects. The results of this study demonstrate that a large number of bearings with inner and outer ring defects of considerable size were operating at or below the temperature range of healthy (defect-free) bearings. This finding is of particular concern because it suggests that many defective bearings can go undetected with the current utilized practice of averaging all bearing temperatures on the same side of the train and focusing on those bearings that are operating at temperatures relatively higher than this average. Moreover, none of the defective bearings tested in the experiments performed for this study reached the HBD alarm temperature threshold of 94.4°C (170°F) above ambient conditions set by the AAR.

The findings of this study, in combination with the costly removal of a relatively large number of *non-verified* bearings from service, demonstrate that the current wayside detection methods of bearing condition monitoring are inadequate, as they tend to rely mainly on temperature data which does not seem to provide a clear distinction between faulty and healthy bearings. Onboard condition monitoring systems that are capable of simultaneously tracking the temperature and vibration signatures of each bearing in the train can prove to be much more effective in assessing bearing health.

Future work includes testing bearings with larger size inner and outer ring defects to add to the library of temperature data that has already been accumulated. Additional work, currently in progress, is focused on studying the effects of spall geometry and location on the bearing operating temperature.

ACKNOWLEDGMENTS

The authors would like to thank Amsted Rail Industries, Inc. for funding this research and permission to publish. The authors also wish to acknowledge the support from the University Transportation Center for Railway Safety (UTCRS) which is funded through USDOT Grant No. DTRT13-G-UTC59.

REFERENCES

- [1] S. Karunakaran, T.W. Snyder, 2007, “Bearing temperature performance in freight cars,” Proceedings Bearing Research Symposium, sponsored by the AAR Research Program in conjunction with the ASME RTD Fall Conference, Chicago, IL, September 11-12.
- [2] C. Tarawneh, B. Wilson, K. Cole, A. Fuentes, J. Cardenas, 2008, “Dynamic bearing testing aimed at identifying the root cause of warm bearing temperature trending,” Proceedings of the 2008 ASME RTD Fall Technical Conference, Chicago, IL, September 24-26.
- [3] K. Cole, C. Tarawneh, A. Fuentes, B. Wilson, L. Navarro, 2010, “Thermal models of railroad wheels and bearings,” Int. J. of Heat Mass Transfer, Vol. 53, pp. 1636-1645.
- [4] C. Tarawneh, K. Cole, B. Wilson, F. Alnaimat, 2008, “Experiments and models for the thermal response of railroad tapered roller bearings,” Int. J. Heat Mass Transfer, Vol. 51, pp. 5794-5803.
- [5] C. Tarawneh, B. Wilson, M. Reed, 2008, “A Metallurgical and Experimental Investigation into Sources of Warm Bearing Trending,” Proceedings of the 2008 IEEE/ASME Joint Rail Conference, Wilmington, DE, April 22-24.
- [6] C. Tarawneh, A. A. Fuentes, J. A. Kypuros, L. A. Navarro, A. G. Vaipan, B. M. Wilson, 2012, “Thermal modeling of a railroad tapered roller bearing using finite element method,” Journal of Thermal Science and Engineering Applications, Vol. 4, No. 3, pp. 9-19.
- [7] A. Zagouris, A. Fuentes, C. Tarawneh, J. Kypuros, A. Arguelles, 2012, “Experimentally validated FEA of railroad bearing adapter operating temperatures,” Proceedings of the 2012 ASME IMECE Conference, Houston, TX, November 9-15.
- [8] D. Kleitzli, C. Cusano, F. Conry, 1999, “Thermally induced failures in railroad tapered roller bearings,” Tribology Transactions, 424, pp. 824-832.
- [9] H. Wang, T.F. Conry, C. Cusano, 1996, “Effects of cone/axle rubbing due to roller bearing seizure on the thermomechanical behavior of a railroad Axle,” Journal of Tribology, Vol. 118, pp. 311-319.
- [10] R. B. Wiley, T.W. Snyder, 2011, Technical Report, “From ATSI to TDTI: Existing Technologies Analysis and Statistical Review Future Technologies,” Transportation Technology Center, Inc. and Union Pacific Railroad.