

Air Force Institute of Technology

AFIT Scholar

Theses and Dissertations

Student Graduate Works

12-1997

Modeling Uptake and Translocation of Lead (PB) in Maize for the Purposes of Phytoextraction

Mark A. Brennan

Follow this and additional works at: <https://scholar.afit.edu/etd>



Part of the [Environmental Engineering Commons](#), and the [Environmental Monitoring Commons](#)

Recommended Citation

Brennan, Mark A., "Modeling Uptake and Translocation of Lead (PB) in Maize for the Purposes of Phytoextraction" (1997). *Theses and Dissertations*. 5587.

<https://scholar.afit.edu/etd/5587>

This Thesis is brought to you for free and open access by the Student Graduate Works at AFIT Scholar. It has been accepted for inclusion in Theses and Dissertations by an authorized administrator of AFIT Scholar. For more information, please contact richard.mansfield@afit.edu.



MODELING UPTAKE AND TRANSLOCATION
OF LEAD (PB) IN MAIZE FOR THE PURPOSES
OF PHYTOEXTRACTION

THESIS

Mark A. Brennan, Major, USMC

AFIT/GEE/ENV/97D-02

DISTRIBUTION STATEMENT A

Approved for public release;
Distribution Unlimited

DTIC QUALITY INSPECTED 3

DEPARTMENT OF THE AIR FORCE
AIR UNIVERSITY
AIR FORCE INSTITUTE OF TECHNOLOGY

Wright-Patterson Air Force Base, Ohio

19980114 120

AFIT/GEE/ENV/97D-02

MODELING UPTAKE AND TRANSLOCATION
OF LEAD (PB) IN MAIZE FOR THE PURPOSES
OF PHYTOEXTRACTION

THESIS

Mark A. Brennan, Major, USMC

AFIT/GEE/ENV/97D-02

Approved for public release; distribution unlimited

DTIC QUALITY INSPECTED 3

The views expressed in this thesis are those of the author and do not reflect those of the
United States Air Force or Department of Defense

AFIT/GEE/ENV/97D-02

MODELING UPTAKE AND TRANSLOCATION OF LEAD (PB) IN MAIZE FOR
THE PURPOSES OF PHYTOEXTRACTION

THESIS

Mark A. Brennan, B.S.
Major, USMC

Presented to the Faculty of the Graduate School of Engineering
of the Air Force Institute of Technology
In Partial Fulfillment of the
Requirements for the Degree of
Master of Science in Engineering and Environmental Management

Member

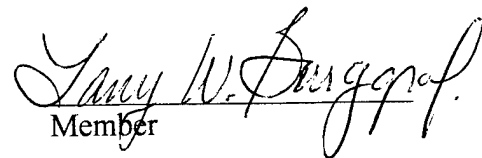
Member

Chairman

AFIT/GEE/ENV/97D-02

MODELING UPTAKE AND TRANSLOCATION OF LEAD (PB) IN MAIZE FOR
THE PURPOSES OF PHYTOEXTRACTION

THESIS

Presented to the Faculty of the
Graduate School of Engineering
of the Air Force Institute of Technology
Air University
Air Education and Training Command
in Partial Fulfillment of the Requirements for the
Degree of Master of Science in Engineering and Environmental Management

Mark A. Brennan, B.S.

Major, USMC

December 1997

Approved for public release; distribution unlimited

Acknowledgments

I would like to begin by thanking my thesis advisor Dr. Mike Shelley. His ability to see the big picture when I was bogged down in minutia helped to keep me pointed in the right direction. The lessons I learned from him concerning the system dynamics approach served me well in this research.

To Dr. Charles Bleckmann and Dr. Larry Burggraf I am also most grateful. Dr. Bleckmann taught me fundamental concepts of plant physiology that were vital for this study. Dr. Burggraf's teaching was enlightening and enjoyable, and provided me with the necessary chemistry knowledge to finish this thesis.

I am also indebted to Scott Cunningham from DuPont Central Research and Development. The conversations I had with him on the topic of phytoextraction, and specific discussions concerning his experimental research with maize, provided me with invaluable insights on relevant plant physiological processes.

The support of my family and friends has been especially important during this past year. In particular, my Christian brothers Captain Tim Wood and Mr. Grady have always been there with sound advice and words of encouragement. Even more important was the support of my wonderful wife Lisa. Without her help and patience this thesis would not have been possible.

Finally, I give the credit for anything I have accomplished here to my Lord and Savior Jesus Christ. As the apostle Paul wrote in Phillipians 4:13, I can do all things through Him who gives me strength.

Table of Contents

	Page
Acknowledgments	ii
List of Figures	vi
List of Tables	x
Abstract.....	xi
I. Introduction	1
Problem Statement	4
Purpose Statement	4
Research Questions	4
II. Literature Review	6
Phytoextraction	6
Bioavailability	8
Plant Anatomy	10
Plant Growth	18
Transpiration and Sap Flow	20
Some Aspects of Maize Growth	21
Uptake and Translocation of Lead	23
Uptake and Translocation of Lead Chelates	41
Models and Modeling	48
III. Methodology	55
Modeling Approach	55
Model Development Process	57
Model Conceptualization and Formulation	59
Reference Mode	59
Basic Mechanisms	60
Model Formulation	62
Model Testing and Validation	63
Model Application	65
IV. Results and Analysis	67

Model Conceptualization – Basic Mechanisms	68
Model Formulation and Presentation	70
Model Software	71
Refinement of Basic Mechanisms	71
Lead in Soil Solution/Pb Uptake	71
Translocation of Pb in the Xylem	72
Translocation of Pb in the Phloem	72
Precipitation of Pb throughout the Plant	72
Plant Growth	72
Plant Transpiration	72
Plant Growth and Physical Parameters	72
Lead Mass and Concentrations	74
Transpiration	74
Root	76
Root Surface and Root Cortex Apoplast (RCA)	77
Uptake into Root Symplast	78
Precipitation in the Root Tissue	78
Root Tissue to Xylem	79
Movement in the Xylem	79
Phloem Flow	80
Stem	81
Movement in the Xylem	81
Movement in the Tissue	82
Movement in the Phloem	82
Leaf	83
Movement of Pb in the Xylem	83
Movement of Pb in the Leaf Tissue	83
Movement in the Phloem	84
Ear	84
Movement of Pb in the Xylem	84
Movement of Pb in the Ear Tissue	84
Movement in the Phloem	
Model Testing and Validation	85
Structure-Verification Test	85
Behavior-Reproduction Test	86
Boundary-Adequacy Test	92
Parameter-Verification Test	92
Behavior-Sensitivity Test	93
Extreme-Conditions Test	98
Behavior-Anomaly Test	98
Phytoextraction Management Scenarios	99

V. Conclusions and Recommendations

Answers to Research Questions	103
-------------------------------------	-----

Model Strengths and Limitations	105
Model Strengths	105
Model Limitations	106
Recommendations	106
Use of the System Dynamics Approach	106
Further Research	107
How to Make Modeling and Experiments More Compatible	108
Appendix A – Model Flow Diagram	110
Appendix B – Model Equations and Code	122
Appendix C – Dry Matter Calculations for Maize	163
Appendix D – Solubility Calculations for Pb	164
Appendix E – Determining Pb Uptake Parameters V_{max} and K_m	178
Appendix F – Model Assumptions	181
Appendix G – Model Output Graphs	184
Bibliography	208

List of Figures

Figure	Page
1. A Generic Plant Cell	12
2. Generic Diagram of a Vascular Bundle	12
3. Cross Section of a Vascular Bundle of a Maize Plant	13
4. A Generic Root	15
5. Cross Section of a Monocot Stem	16
6. Cross Section of a Maize Leaf	17
7. Transection of Maize Root Showing Apoplastic and Symplastic Pathways	18
8. Enlarged View of Apoplastic and Symplastic Pathways for Ion Transport	18
9. Typical Plant Growth Curve	19
10. Pathway of Water and Solutes into the Stele and Xylem	27
11. Carriers and Channels Enabling Solute Crossing of the Plasmalemma	28
12. Michaelis-Menten Uptake Curves for Na and K	30
13. Multiphasic Uptake Kinetics of Phosphate by Maize Roots	32
14. Reference Mode	60
15. Generic Influence Diagram	61
16. Influence Diagram	70
17. Daily Transpiration	76
18. Baseline Model Output	87
19. Baseline Model Output with Effective Root Mass Mechanism	88
20. Baseline Model Output with Decreasing Vmax Mechanism	89

21. Baseline Model Output with Effective Root Mass and Vmax Mechanisms	90
22. Baseline Model Output in Roots with and without Hypothesized Mechanisms	91
23. Baseline Model Output in Shoots with and without Hypothesized Mechanisms	91
24. Root Concentration Varying Root Surface Partition Rates	95
25. Shoot Concentration Varying Root Surface Partition Rates	95
26. Root Concentrations Varying Precipitation Rates	97
27. Shoot Concentrations Varying Precipitation Rates	97
28. Root Concentration Varying Pb Concentration in Soil Solution	100
29. Shoot Concentration Varying Pb Concentration in Soil Solution	100
30. Root Concentrations when Transfer Rate Coefficient is Varied	184
31. Shoot Concentrations when Transfer Rate Coefficient is Varied	184
32. Shoot Concentrations with and without Diffusion Mechanism in Ear/Leaf	185
33. Root Concentrations with and without Diffusion Mechanism in Ear/Leaf	185
34. Root Pb Concentrations with and without Adsorption Mechanism in Ear/Leaf	186
35. Shoot Pb Concentrations with and without Adsorption Mechanism in Ear/Leaf	186
36. Root Pb Concentrations Varying Root Surface Partition Coefficient	187
37. Shoot Pb Concentrations Varying Root Surface Partition Coefficient	187
38. Root Concentrations Varying the Solubility Product	188
39. Shoot Concentrations Varying the Solubility Product	188
40. Root Concentration Varying Root Surface/RCA Precipitation Factor	189
41. Shoot Concentration Varying Root Surface/RCA Precipitation Factor	189
42. Root Concentration Varying RFS Fraction	190
43. Shoot Concentration Varying RFS Fraction	190

44. Root Concentration Varying Km	191
45. Shoot Concentration Varying Km	191
46. Root Concentration Varying Vmax	192
47. Shoot Concentration Varying Vmax.....	192
48. Root Concentration Varying Effective Root Mass	193
49. Shoot Concentration Varying Effective Root Mass.....	193
50. Root Concentration Varying Growth and Vmax Retardation	194
51. Shoot Concentration Varying Growth and Vmax Retardation.....	194
52. Root Concentration Varying Xylem CEC Goal.....	195
53. Shoot Concentration Varying Xylem CEC Goal	195
54. Root Concentration Varying Root and Stem Xylem CEC Factors.....	196
55. Shoot Concentration Varying Root and Stem Xylem CEC Factors	196
56. Root Concentration Varying Xylem Fractions	197
57. Shoot Concentration Varying Xylem Fractions.....	197
58. Root Concentration Varying Phloem Fractions	198
59. Shoot Concentration Varying Phloem Fractions	198
60. Root Concentration Varying Stem Xylem Flow Transpiration Factors	199
61. Shoot Concentration Varying Stem Xylem Flow Transpiration Factors.....	199
62. Root Concentration Varying Xylem-Phloem Transfer Fractions	200
63. Shoot Concentration Varying Xylem-Phloem Transfer Fractions.....	200
64. Root Concentration Varying Maximum Phloem Flow Rate.....	201
65. Shoot Concentration Varying Maximum Phloem Flow Rate	201
66. Shoot Concentration Varying Plant Mass Fractions.....	202

67. Root Concentration Varying Plant Mass Fractions	202
68. Root Concentration Varying Maximum Shoot Dry Mass	203
69. Shoot Concentration Varying Maximum Shoot Dry Mass.....	203
70. Root Concentration Varying Root and Shoot Water Fractions	204
71. Shoot Concentration Varying Root and Shoot Water Fractions.....	204
72. Root Concentration Varying Shoot to Root Ratios	205
73. Shoot Concentration Varying Shoot to Root Ratios	205
74. Root Concentration Varying Production/Maintenance Transpiration Factors	206
75. Shoot Concentration Varying Production/Maintenance Transpiration Factors.....	206
76. Root Concentration Varying Transpiration Coefficient	207
77. Shoot Concentration Varying Transpiration Coefficient.....	207

List of Tables

Table	Page
1. Lead Concentration in Plants from Soil and Nutrient Solution Experiment	41
2. Relative Uncertainty of Model Mechanism Characterization	86
3. Model Parameter Uncertainty and Behavior Sensitivity	94
4. Shoot Accumulation of Pb during the Growing Season	101
5. Shoot Accumulations Surging Pb Concentration in Soil Solution	101

Abstract

Phytoextraction is a remediation technology that uses plants to remove heavy metals from soil. This technology has the potential to decrease the costs of remediating contaminated sites by several orders of magnitude compared to traditional technologies. To effectively implement this technology requires an understanding of the plant processes that control uptake and translocation of metals from the soil. Currently these processes are poorly understood, and especially so for Pb.

The purpose of this thesis was to gain insights concerning the plant mechanisms that control uptake and translocation of Pb from the soil, and how these mechanisms interact to control levels of Pb accumulation in the plant. This was accomplished by developing, testing, and implementing a system dynamics model that simulated a maize plant taking up and translocating Pb.

As a result of a rigorous process of conceptualization, formulation, and testing, it appears that this model is a valid tool for studying uptake, translocation, and accumulation of Pb. The results suggest that precipitation of Pb as a Pb-phosphate at the root surface and throughout the plant is one of the most important mechanisms in this system. The maximal uptake rate of Pb (V_{max}) and effective root mass may also be key plant parameters in this process. The model may also be used to test various phytoextraction management scenarios, two of which were tested in this study.

MODELING UPTAKE AND TRANSLOCATION OF LEAD (Pb) IN MAIZE FOR THE PURPOSES OF PHYTOEXTRACTION

1. Introduction

According to the Environmental Protection Agency (EPA), lead (Pb) is the most common heavy metal contaminant in the environment (Watanabe, 1997: 183A). Human activities such as mining, smelting, burning of fossil fuels, dumping of municipal sewage sludge, and the manufacture of pesticides and fertilizers are the primary causes of this contamination (Kabata-Pendias and Pendias, 1992). Lead is a nonessential element in metabolic processes and may be toxic or lethal to organisms even when absorbed in small amounts (Walker and others, 1996: 4-6). Given its potential hazard and widespread contamination, there is great deal of interest in methods aimed at cleaning up Pb at minimal costs and with the fewest environmental side effects.

Traditional methods of remediating Pb contaminated sites include a variety of physical, thermal, and chemical treatments, as well as manipulations to accelerate or reduce mass transport in the contaminated matrix (Cunningham and others, 1997: in press). Using conventional methods of remediation, the estimated costs of cleaning up the sites in this nation that are contaminated with heavy metals alone has been estimated at \$7.1 billion dollars, and \$35.4 billion for sites that are contaminated with both heavy metals and organic pollutants (Salt and others, 1995: 468). An emerging technology that shows great promise for remediating these sites at greatly reduced cost and with minimal

adverse side effects is called phytoremediation.

Phytoremediation is the use of plants to remediate soils that are contaminated with organic or inorganic pollutants (Cunningham and Ow, 1996: 715-717). Phytoextraction is a type of phytoremediation that involves removing heavy metals from contaminated soils with plants that accumulate large concentrations of heavy metals (termed hyperaccumulation). It involves: growing plants that hyperaccumulate heavy metals on contaminated sites; harvesting the plants; selling the harvested plants to buyers that can extract and process the metals for further use, or disposing of them as hazardous waste (Cunningham and others, 1995: 42-43). While conventional methods of remediation may cost from \$10 to \$1000 per cubic meter, phytoextraction costs are estimated to be orders of magnitude less, perhaps as low as \$0.05 per cubic meter (Cunningham and others, 1997: in press). Due to its enormous potential for cost savings, there is significant interest in this technology that is currently in the developmental stage and on the brink of commercialization (Watanabe, 1997: 182A).

For phytoextraction to be a feasible remediation tool, plants that are used must have the following capabilities: uptaking large concentrations of heavy metals into the roots; translocating these metals to the shoots so that large concentrations are accumulated in the shoots; accumulating high biomass (Cunningham and others, 1995: 43-44). Though there are a number of plants that possess two of these qualities, no plants have yet been discovered or developed that possess all three qualities for Pb (Cunningham and others, 1995: 45). To overcome these shortfalls, the use of heavy metal chelators such as ethylenediaminetetraacetic acid (EDTA) have been applied to

soils to make more Pb bioavailable for plant uptake. In several experiments, the use of these chelators has dramatically increased the amount of Pb that plants took into their roots and translocated to their shoots. The plants also appeared to have sufficient biomass to be used in phytoextraction (Huang and others, 1997: 802-804). The mechanisms within the plants that caused this huge surge in Pb uptake and translocation are poorly understood (Huang and others, 1997: 804). Additionally, the use of these chelators in the phytoextraction process creates problems: remediation costs are increased and metals that are mobilized by the chelators can migrate offsite and contaminate other areas such as the groundwater (Cunningham and others, 1997). Under these circumstances, the preferred method of phytoextraction would be to find plants that hyperaccumulate metals in sufficient quantities in their shoots without applying chelators such as EDTA to the soil. No such plants currently exist, but it is hoped that through the process of selective breeding and/or genetic engineering, plants may be developed which have the required characteristics (Watanabe, 1997: 183A and Cunningham and Ow, 1996: 718).

Plant species vary significantly in their ability to uptake Pb and translocate it to their shoots (Huang and others, 1996). Some plants such as *Thalspi rotundifolium* can hyperaccumulate Pb in the roots, yet cannot effectively translocate the Pb to the shoots, nor does this plant have sufficient biomass. Others such as maize (*Zea mays*) appear to be efficient at translocating Pb to the shoots from the roots and have high plant biomass, but are not good at taking Pb into the roots. It is hoped that by selective breeding or genetic engineering these species variations in Pb uptake and translocation may be exploited. In this manner, plants may be developed that have all of the desired

characteristics for phytoextraction. For this to be successful, the plant mechanisms that control the uptake and translocation of Pb must be understood. At present, understanding of these mechanisms is poor and needs further study (Kumar and others:1235).

Problem Statement

The mechanisms that control plant uptake of Pb into the roots, translocation of Pb from the roots to the shoots, and how these mechanisms interact to affect the accumulation of Pb in plant roots and shoots are poorly understood. This lack of understanding hinders the efforts of researchers in their quest to develop plants that will be suitable for phytoextraction of Pb from contaminated soils.

Purpose Statement

Through the process of building a model that simulates a plant with respect to uptake and translocation of Pb, and applying the model to various phytoextraction management situations, gain insights into the mechanisms that control plant uptake of Pb from the soil and translocation of Pb from the roots to the shoots, and how these mechanisms interact to control the accumulation of Pb. The insights gained through this research effort should be useful to researchers who are trying to remediate contaminated soils through the process of phytoextraction.

Research Questions

1. What are the mechanisms within a plant that control uptake of Pb from a soil system?
2. What are the mechanisms within a plant that control the translocation of Pb from the roots to the shoots?

3. How do the mechanisms that control uptake and translocation of Pb feedback upon each other to determine the levels of Pb that will accumulate in the roots and shoots?
4. Which plant mechanisms are most important in determining the levels of Pb that will accumulate in a plant so that they will be readily available for phytoextraction?
5. How do levels of Pb accumulation in a plant vary as levels of input and magnitude of feedback for different mechanisms are varied?
6. What time frames may be the best for harvesting plants or applying chelates in the phytoextraction process?

2. Literature Review

The literature review was conducted with six objectives. The first was to become familiar with the technology of phytoextraction. The second was to understand what it means for Pb to be bioavailable for uptake by a plant. The third objective was to gain a basic understanding of plant anatomy and physiology as they are relevant to phytoextraction. This review specifically focused on *Zea mays* (maize) since this plant appears to have high potential for phytoextraction and is used in the modeling effort. The fourth objective was to review and understand how a plant grows, develops, and transpires. The fifth was to gain an in-depth understanding of how plants uptake and translocate Pb and Pb-chelates, and how the uptake and translocation affects the growth and development of the plants. The sixth and final objective was to review some of the different modeling approaches, specifically focusing on those that address uptake and translocation of inorganic contaminants.

Phytoextraction

The field of phytoextraction is relatively new, with the vast majority of research being done in the last several years. As mentioned previously, phytoextraction is likely to be many times less expensive than traditional remediation techniques. Additional benefits from this approach are that it may be feasible to implement over wide areas of contamination and it leaves the physical and biological structure of the soil intact (Baker and others, 1994: 42). One of the primary disadvantages of phytoextraction is that it is expected to take between 3 and 20 years to remediate a site depending upon the level of

contamination (Huang and others, 1997: 800). However, research by Jorgensen (1993: 100) has shown that by using EDTA as a soil amendment and growing maize on a contaminated test plot, 11 percent of the total Pb could be removed from the soil in one harvest. This suggests that soil contamination levels may be reduced to allowable limits within several harvests and nearly all of the Pb could be removed within five years. Therefore, time constraints of phytoextraction may not be as significant as once thought. Another disadvantage is that it can only be used on soils that are lightly or moderately contaminated because most heavily contaminated soils do not support plant life (Kumar and others, 1995: 1233).

For phytoextraction to be feasible requires plants that accumulate high concentrations of metals in their shoots and have high biomass. Translocation of the metals from the roots to the shoots is an important factor because it lessens worker exposure to the contaminants and makes harvesting easier (Cunningham and Ow, 1996: 717). An engineering cost evaluation has determined that for site decontamination to occur within 10 harvests, plants must have metal accumulation levels in the shoots of 1 to 3% dry weight (Cunningham and others, 1995: 44).

The final steps in phytoextraction are harvesting the plants and disposing of them. If the heavy metals targeted for phytoextraction have sufficient economic value, such as zinc and cadmium, the harvested plants undergo a biomass-processing step to remove the metals. Assuming that 20 tons of biomass per hectare per harvest would be produced, researchers have hypothesized that the metals could be worth as much as \$1069 per hectare (Watanabe, 1997: 184A). Metals such as Pb do not currently have such

economic value. After harvesting, plants containing Pb could be reduced in volume and/or weight by thermal, microbial, physical or chemical means and disposed of. This step would decrease handling, processing, and potential landfilling costs (Cunningham and Ow, 1996: 717).

Initial research concerning the phytoextraction of Pb determined that there did not appear to be any plants that could approach the goal of 1% to 3% dry weight Pb accumulation in the shoots when grown in soil (Cunningham and others, 1995: 45). Research thus turned to: describing the plant physiology of Pb uptake, translocation, and tolerance, and eliminating the rate-limiting step by the use of engineering, chemical, or physical adjuncts; creating better plants suited for phytoextraction through selection, breeding, or molecular biological techniques.

Bioavailability

One of the major barriers to the success of Pb phytoextraction has been that Pb is normally not very bioavailable in the soil for uptake by plants. It was speculated that if more Pb was bioavailable for uptake in the soil, accumulation of Pb in plant shoots could be significantly increased (Huang and others, 1997). There are numerous factors that interact to determine what quantity of Pb contained in soils will be bioavailable for uptake by plants. A thorough review of all of these factors is beyond the scope of this paper. However, a brief discussion of bioavailability is warranted because it is only those metals that are bioavailable in soils that a plant can take up into its roots.

Bioavailable metals in this research are defined as those metals that a plant is capable of taking up into its roots from the soil. It includes those metals that are in soil

solution or that can readily dissolve in soil solution, and those that are in ionic form or in soluble complexes (Ernst, 1996: 164, Davies, 1990: 787, Corey and others, 1981: 451, and Kabata-Pendias and Pendias, 1992: 67). The final arbiter of what metals are bioavailable, however, are plants in the amount of metals that they uptake into their roots (Loneragan, 1975: 110 and Berti and others, 1996).

The concentration of metals in soil solution is different from the concentration of metals in the soil. For example, metals may be adsorbed to clays, precipitated as hydroxides, or bound to organic matter in soil (Arnfolk and others, 1996: 132). This limits the amount of metals that will dissolve in soil solution and thus be bioavailable for uptake. Bioavailability is usually measured by sequential extraction techniques. In this process, a sequence of chemicals is used to solubilize metals from the soil matrix into soil solution. The first chemical used is usually deionized water, and the chemicals gradually get harsher at each level with the final extractant being a very strong acid. The bioavailable metals are usually considered to be those that are water soluble or dissolvable in a very mild acid (termed exchangeable) (Ernst, 1996: 164 and Farago, 1981: 684). Generally, there is a poor correlation between the total metal content in the soil and plant uptake of those metals, whereas better correlations have been observed for extractable forms of metals (Chlopecka, 1996: 297).

Lead has limited solubility in soils, and therefore limited bioavailability, due to complexation with organic matter, sorption on oxides and clays, and precipitation as carbonates, hydroxides, and phosphates (Blaylock and others, 1997: 860). Experiments conducted by Arnfolk and others (1996: 135-139) showed that in many soils, only a small

fraction of Pb in soils is soluble at pH's above 6. These results strongly suggest that Pb has low bioavailability to plants under most soil conditions. The research of Blaylock and others (1997:860-862) and Huang and others (1997) also supports these findings.

Research by Lindsay (1979: 334-335) suggests that Pb^{2+} solubility in soils is controlled by phosphates. As phosphate levels increase, Pb^{2+} solubility tends to decrease. His research also suggests that as pH increases past 7.5, Pb^{2+} solubility decreases, and that as pH decreases below 6, Pb^{2+} solubility increases. Lindsay also suggests that Pb^{2+} levels in soils with pH from 5.5 to 7.5 are normally on the order of $10^{-8.5}$ molar. Research by McBride (1994: 336) also supports the assertion that as pH increases Pb^{2+} becomes less soluble.

Zimdahl and Koeppe (1977: 102) cite studies by MacLean and others that decreasing pH increased the uptake of Pb by alfalfa and oats, and increasing phosphate concentration decreased the uptake of Pb. Koeppe (1977: 198) cites several other studies showing that high pH and increased phosphate reduced Pb uptake. In a more recent study Huang and others (1996) found that increasing phosphate levels in soils decreased the Pb concentrations in maize plants. The study of these researchers, when taken in concert with the work of Lindsay and McBride, strongly suggests that Pb^{2+} is the species of Pb that is most important when considering bioavailability.

Plant Anatomy and Physiology

In this section the structure and functioning of plant cells, vascular tissue, roots, stem, and leaves are examined, and the concepts of the apoplast and symplast are discussed. As referred to in this thesis, the shoots are all aboveground parts of the plant.

The cell is the basic unit of which organisms are constructed (Fahn, 1990: 10). Plant cells are distinguished from cells of other organisms in that they have both cell walls and chloroplasts (Forbes and Watson, 1992: 2). Figure 1 is a picture of a generic plant cell. The cell wall provides rigidity and is much more permeable than the plasmalemma. It is composed of cellulose and other polysaccharides. Just internal to the cell wall is the plasma membrane, or plasmalemma, which regulates materials entering or leaving the cell through selective permeability. The vacuole is the large central aqueous phase of the cell that can occupy up to 90 percent of the volume of mature cells. The vacuole is surrounded by a membrane called the tonoplast (Nobel, 1991: 1-2 and Hartmann and others, 1988: 18). External to the vacuole but internal to the plasmalemma lies the cytoplasm. The cytoplasm is granular in appearance and contains numerous other organelles such the mitochondria and chloroplasts (Nobel, 1991: 2 and Forbes and Watson, 1992: 3). Surrounded by the cytoplasm is the nucleus, which is usually spherical in shape and contains a cell's chromosomes (Fahn, 1990: 20). The living part of the cell, everything contained inside of the cell wall is often referred to as the protoplast (Nobel, 1991: 1).

The xylem and phloem constitute the vascular bundles in a plant that run from the roots to the stem to the leaves (Nobel, 1991: 4). Figure 2 shows a generic diagram of a vascular bundle in the stem of a plant. In dicotyledoneous plants, vascular bundles contain a layer of cambial cells that can produce secondary xylem and phloem. In monocotyledoneous plants, like maize, the vascular bundles contain no such cambial layer (Salisbury and Ross, 1992: 97-99).

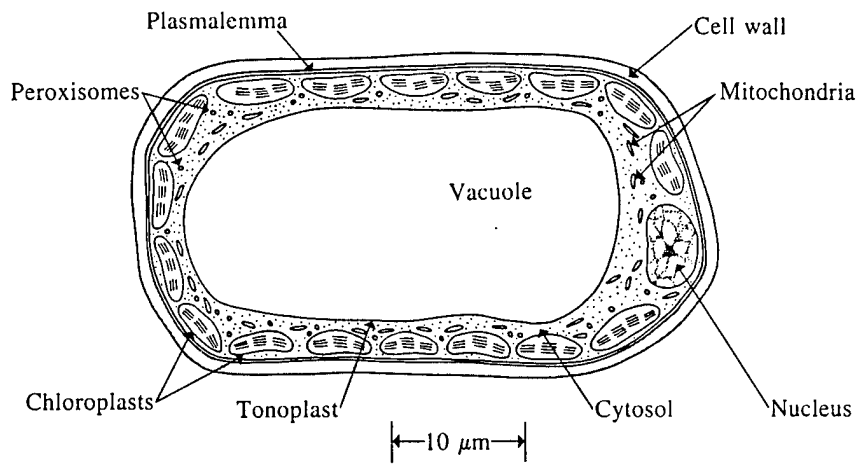

Figure 1 – A generic plant cell (Nobel, 1991: 2)

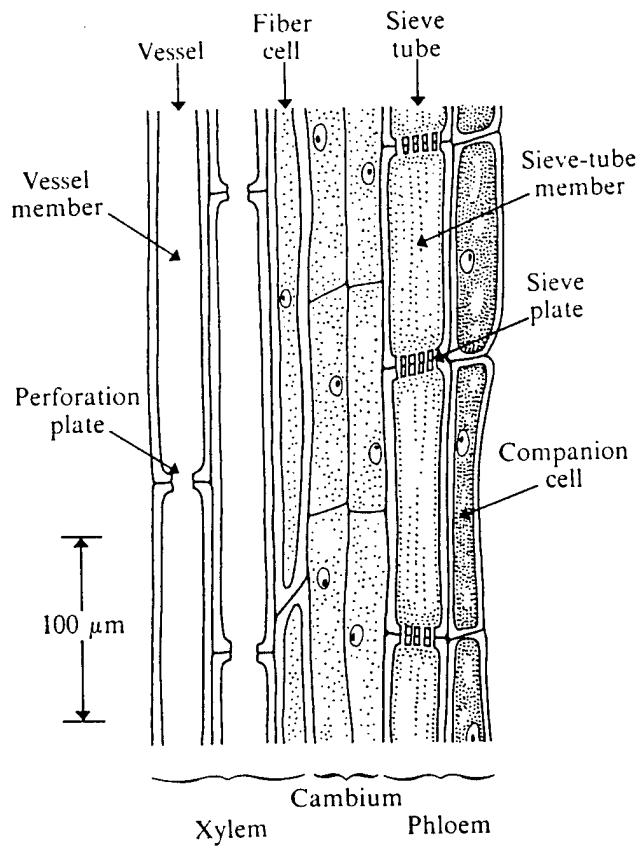

Figure 2 – Generic diagram of a vascular bundle (Nobel, 1991: 5)

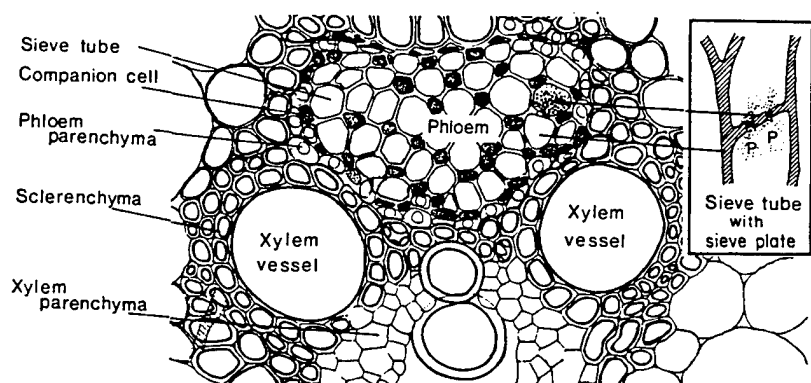

Figure 3 – Cross section of a stem vascular bundle in maize (Marschner, 1986: 83)

Xylem is the tissue that conducts water and dissolved minerals from the roots to the shoots (Hartmann and others, 1988: 23). As shown in Figures 2 and 3, it may contain four kinds of cells: tracheids (not shown), vessel elements, fibers, and xylem parenchyma (Hartmann and others: 99). The conducting cells in xylem are the narrow and elongated vessel elements. Many plants do not contain tracheids, which serve the same purpose as vessel elements, but are longer and narrower. Vessel elements are joined end-to-end in long linear files, their adjoining end walls having from one large to many small holes. The conducting cells lose their protoplasts, and the remaining cell walls thus form a low-resistance channel for the passage of solutions (Nobel, 1991: 6).

Phloem conducts food and metabolites from the leaves to other parts of the plant (Figures 2 and 3). It is comprised of sieve-tube members, companion cells, fibers, and parenchyma (Hartmann and others, 1988: 24). Sieve-tube members are long slender cells with porous ends called sieve plates. Companion cells aid in metabolite conduction and are associated with sieve-tube members. Fibers are thick-walled cells that provide stem support. Phloem parenchyma cells serve as storage sites (Hartmann and others, 1988:24).

Roots are responsible for absorbing and conducting water and nutrients, and for anchoring and supporting the plant (Hartmann and others, 1988: 24). As shown in Figure 4, the root cap is situated at the tip of the roots. It protects the root meristem and aids the penetration of the root growing into the soil (Fahn, 1990: 271). The apical meristem is the region where the cells rapidly divide and which has thin cell walls (Nobel, 1991: 8). The outer layer of cells on the roots, which are somewhat flattened, are called the epidermis. From the epidermis long projections develop that extend out among the soil particles called root hairs. Root hairs greatly increase soil-water contact and enhance water absorption and the volume of soil penetrated (Salisbury and Ross, 1992: 102). Comprised of several layers of relatively large, thin-walled cells and abundant intercellular air space is the cortex. This air space appears to be essential for internal aeration of the root (Salisbury and Ross, 1992: 102 and Nobel, 1991: 8). A single layer of cells inside of the cortex forms the endodermis. Each thin-walled endodermal cell is completely encircled by a narrow, thickened band of waterproof material known as the Casparian strip. The solution of water and nutrients entering the root from the soil cannot penetrate the Casparian strip, and therefore must cross the plasmalemma into the cell before it can reach the vascular tissue (Hartmann and others, 1988: 27-28 and Salisbury and Ross, 1992:101). Just inside the endodermis is a layer of living cells called the pericycle. The innermost layer of a root is the vascular tissue, comprised of the xylem, phloem and their parenchyma cells. The vascular tissue and pericycle together comprise a tube of conducting cells called the stele (Salisbury and Ross, 1992: 101).

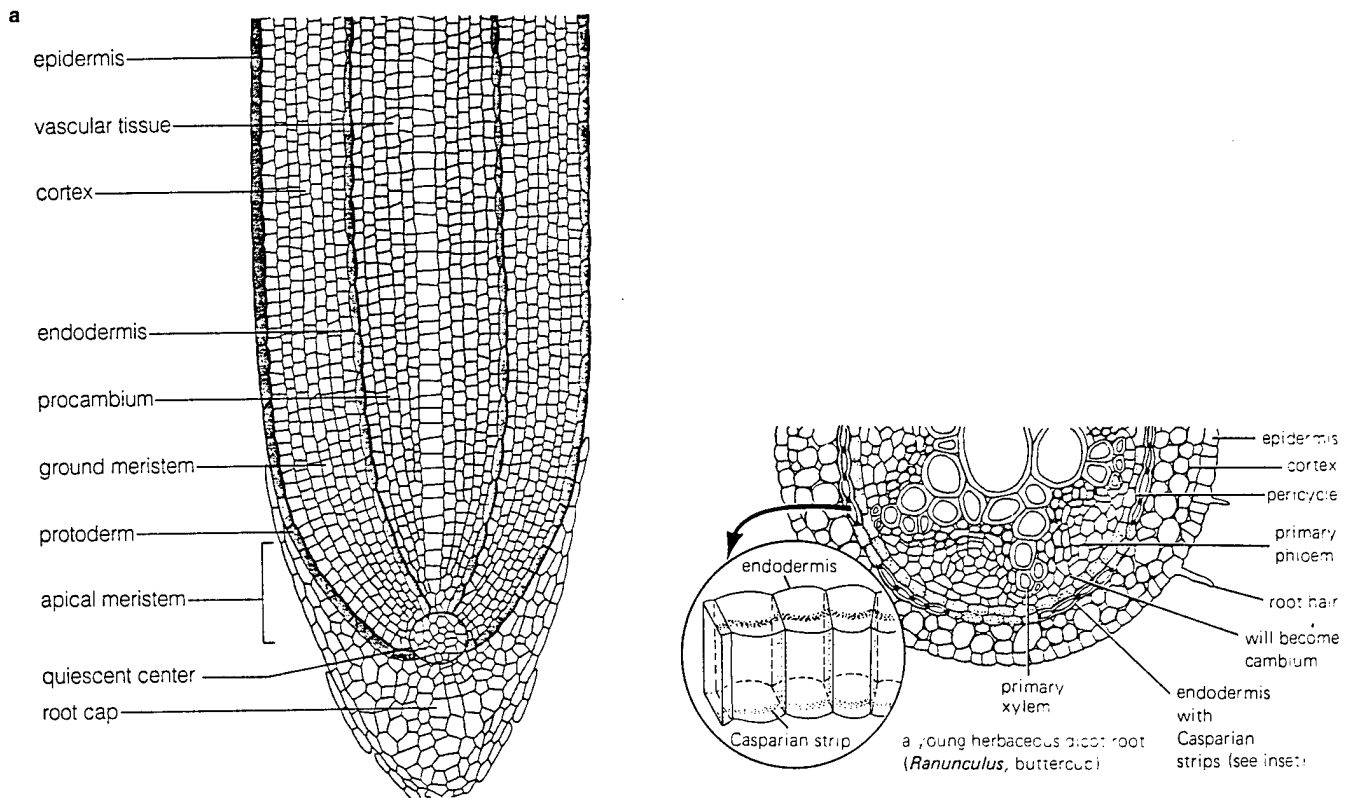

Figure 4 - A generic root (Salisbury and Ross, 1992: 101)

The stem is the scaffold of the plant, supporting the leaves, flowers, and fruit ((Hartmann, 1988: 28). The epidermis, as shown in Figure 5, is usually a single layer of cells that protects the stem. The cortex lies just beneath the epidermis and encircles the vascular tissue in dicot plants, with vascular bundles being scattered throughout the stem in monocots such as maize. The cortex comprises parenchyma, collenchyma, and sclerenchyma, with parenchyma being most numerous. Parenchyma cells, some of which have chloroplasts, have the ability to divide and form new tissue when wounded, thus providing a protective mechanism for the stem. Collenchyma is the outer cell layer of

the cortex adjacent to the epidermal layer. This tissue adds strength to the stem, as does the sclerenchyma, which has thick lignified walls (Hartmann and others, 1988: 28)

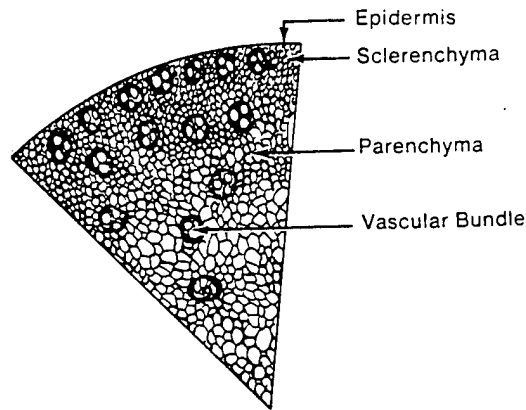

Figure 5 – Cross-section of a monocot stem (Hartmann and others, 1988: 31)

The main function of leaves is the synthesis of organic compounds using light as the source of necessary energy (photosynthesis). The structure of the leaf corresponds to its role in photosynthesis and transpiration (Fahn, 1990: 8). As shown in Figure 6, the epidermis occurs on both the upper and lower sides of a leaf, and is usually one layer of cells thick. Epidermal cells have a relatively thick waterproof layer called the cuticle. Between the epidermal layers is the mesophyll tissue, which in many plants is differentiated into palisade and spongy cells (Nobel, 1991: 3-4). In maize there is no differentiation in the mesophyll cells (Fahn, 1990: 225-226). The epidermal layer has openings or pores called stomata, each surrounded by two guard cells (Hartmann and others, 1988: 35). Maize also contains bulliform cells in the epidermis. These cells are larger than typical epidermal cells and their function is uncertain (Fahn, 1990: 161-162). Vascular bundles run through the leaf surrounded by the mesophyll cells.

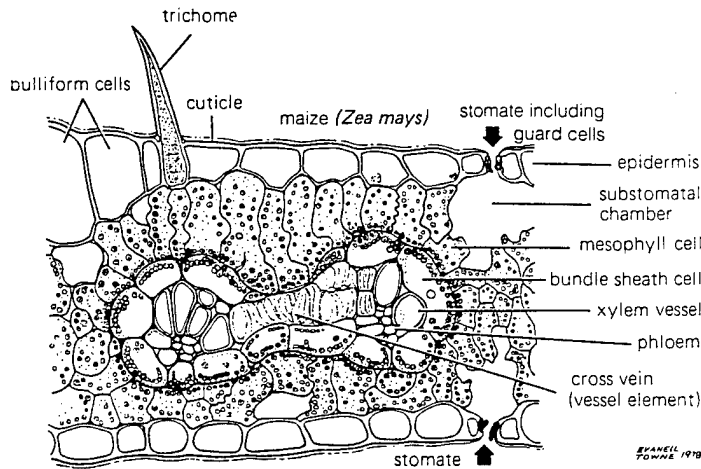

Figure 6 – Cross section of a maize leaf (Salisbury and Ross, 1988: 71)

The final topic in this section is the concept of the apoplast and the symplast, first proposed by Munch in 1930 (refer to Figures 7 and 8). The interconnecting cell walls and the xylem elements of a plant, all of the nonliving parts, are considered as a single unit called the apoplast (Salisbury and Ross, 1992: 102). The apoplast is porous and both water and solutes can move freely through it. The apoplast is not continuous throughout the entire plant, but is instead divided by the endodermis (Caspasian strip) into an outer region which is continuous with the soil solution, and an inner region continuous with the xylem sap (Forbes and Watson, 1992: 40). Therefore, ions entering a plant through the root must cross into the symplast in order to be transported to the shoots.

The symplast is the living part of the plant and includes the cytoplasm of all the cells. All of the adjoining cells in a plant are interconnected by plasmodesmata (Salisbury and Ross, 1992: 103). Plasmodesmata are fine membrane-flanked cytoplasmic threads that pass from a protoplast, through a pore in a cell wall, directly to the protoplast in another cell (Nobel, 1991: 37). It is estimated that there are one million

plasmodesmata per square meter in a plant (Salisbury and Ross, 1992: 141). Because of these plasmodesmata, once a solute crosses a plasmalemma into a cell root it could theoretically move through a plant all the way to the leaves in the symplast without ever crossing another membrane and entering the apoplast. However, this does not appear to actually occur. Instead solutes appear to be carried to the shoots through the xylem, which is part of the apoplast. This is discussed further in a subsequent section.

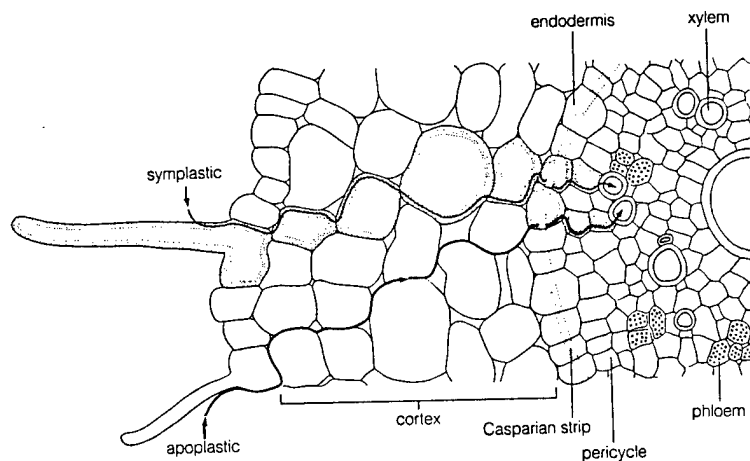

Figure 7 – Root transection showing symplastic/apoplastic pathway of ion transport across a root (Salisbury and Ross, 1992: 140)

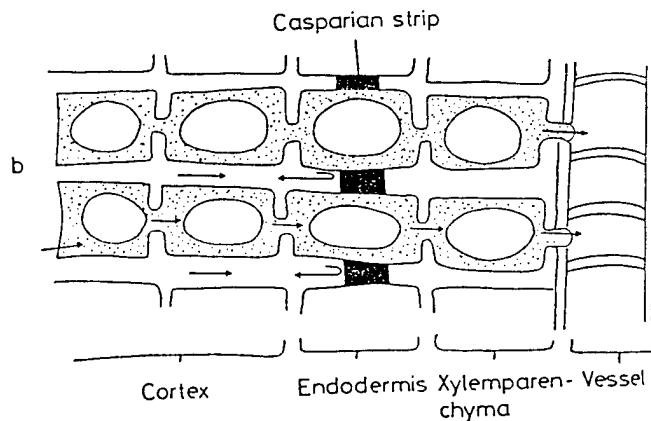

Figure 8 – Enlarged view of apoplastic/symplastic paths (Mengel and Kirkby, 1987: 204).

Plant Growth

The pattern of growth of a plant over a generation is typically characterized by a

growth function referred to as a sigmoid (S – shaped) curve (Gardner and others, 1985: 199). The time frame may vary from less than days to years but the sigmoid pattern typifies all plants, organs, tissues, and even cell constituents. A sigmoid curve representing typical plant growth is sketched out in Figure 9.

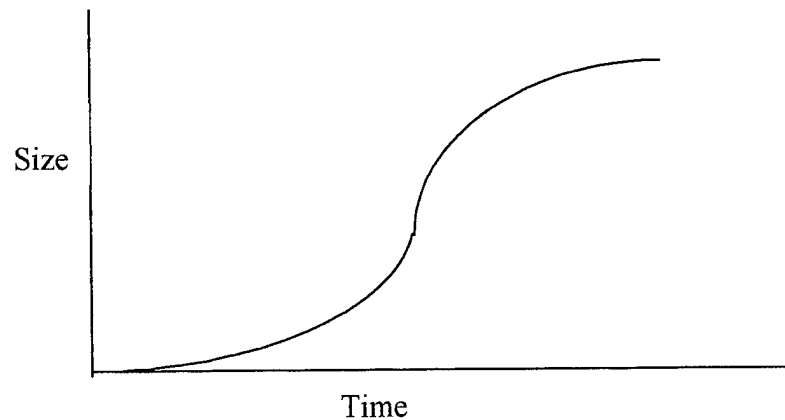

Figure 9 – Typical plant growth curve

A significant research finding has been that Pb uptake appears to have a negative impact upon plant growth. Miller and others (1977: 20) found that soil concentrations of 125 and 250 micrograms Pb per gram of soil significantly reduced the growth of the maize shoots. Hassett and others (1976: 299) found that maize root growth was significantly inhibited at soil concentrations of Pb greater than 250 micrograms per gram. Jones and others (1973: 616) also found that when shoots Pb concentrations of perennial ryegrass increased there was a marked decrease in plant dry mass. Tyler and others (1989: 202) have cited studies showing that there is decreased root production in maize from solution concentrations as low as 0.21 mg/liter. They also note that impeded root development is almost always the first sign of heavy-metal toxicity.

In more recent studies, Huang and Cunningham (1996: 77) found that both maize

and ragweed grown in hydroponic solutions containing micromolar concentrations of Pb had significantly reduced biomass. Both shoots and root biomass decreased linearly with increasing concentrations of Pb. In a separate study, Huang, Cunningham, and Germani (1996) found that plants grown on Pb contaminated soils showed symptoms of severe phosphorus (P) deficiency that caused a near cessation in biomass production. When foliar P was applied to goldenrod plants grown on Pb contaminated soils, plant biomass increased four-fold in comparison to plants that did not receive the foliar P treatment.

Transpiration and Sap Flow

Transpiration is the loss of water from plants in the form of vapor. It is the dominant process in plant water relations because of the large volume of water involved and its controlling influence on plant water status (Kramer and Boyer, 1995: 201). It also produces the energy gradient that controls the absorption and the ascent of sap in the xylem. Therefore, the velocity of sap flow varies with the rate of transpiration (Kramer and Boyer, 1995: 255). The current of sap that is drawn through the plant in response to transpiration is called the transpiration stream (Milburn, 1979: 110). The bulk of the water that enters a plant moves through the xylem to the evaporating surfaces of the leaves where it eventually is transpired (Westgate and Boyer, 1983: 882), and a small fraction moves to the growing regions where it causes expansion growth.

Transpiration varies during the course of a day (Kramer and Boyer, 1995: 207) and a growing season (Milburn, 1979: 111). The daily amount of water transpired by maize during a growing season, and how it varies depending upon the stage of plant development, does not appear to be available in literature. However, studies have been

conducted that estimate the liters of water that a maize plant will transpire to produce one kilogram of dry mass during a growing season. Kramer and Boyer (1995: 203), citing a study done by Miller, show this transpiration ratio varying from 253 to 495. Mengel and Kirkby (1987: 236) cite a figure of 349, and Forbes and Watson (1992: 59) 329, for this transpiration ratio.

Another point of interest is the relative rates of transpiration in the different plant organs. It appears that very little transpiration occurs in fruit, or in the case of maize, the ear (Marschner, 1986: 99). The majority of transpiration appears to take place in the leaves with some transpiration also taking place in the stem (Kramer and Boyer, 1995: 204 and 228).

Phloem sap flow rates are significantly slower than the xylem (Marschner, 1986: 91 and Nobel, 1991: 510 and 515). Phloem sap flow rates will reach their maximum value when plant leaves are mature and begin to senesce (Marschner, 1983:20-24, Salisbury and Ross, 1992: 164 and 181, Kochian, 1991: 249, and Marschner, 1986: 87). This is because flow in the phloem appears to occur according to the Munch hypothesis, which is discussed in the next section.

Some Aspects of Maize Growth

The size of maize plants can vary widely based upon the plant variety and whether the plant it is a hybrid or inbred (Newlin and others, 1949: 34). For example, the stalks can vary in height from about 1 ½ feet to about 30 feet, and maize from Central America moved north often grows to a height of 15 feet or more (Newlin and others, 1949: 69). Accordingly, total dry weight of the shoots of a maize plant at maturity can

vary widely. A typical hybrid variety grown in the cornbelt of the midwest could be expected to accumulate about 350 grams of dry matter at maturity (Hanway and Russell, 1966: 949 and Salvador, 1997: personal communication). Of that 350 grams, about 55 percent comprises the ear, 20 percent comprises the leaves, and 25 percent comprises the stem (Ritchie and others, 1997: WWWeb and Hanway, 1966: 16). These percentages will vary considerably during the growing season as different parts of the maize plant mature at different rates.

During the first several weeks of the growing season the leaves comprise the largest fraction of plant matter. That fraction declines as the stem and ears begin to mature. A few weeks after emergence of the first sprouts from the soil the stem begins a period of rapid growth that continues until several weeks after the ear appears. The fraction of total plant mass that comprises the ear is zero until about 50 days after emergence when the ear first begins to form. The fraction of the shoots mass comprised of the ear then continues to increase until maturity of the plant (Ritchie and others, 1997: WWWeb and Hanway, 1966: 16).

The growth of the root is much harder to gauge, but ratios of shoots mass to root mass usually vary from 5:1 to 1:1 (Salvador, 1997: personal communication). Gavloski and others (1992: 367) found that shoots to root ratios varied from 2.5:1 to 4.1:1. Kramer and Boyer (1995: 140) cite a study by Bray that shows average shoots to root ratios for maize to be about 1.9:1.

The pattern of maize growth in the roots is also of interest. Kramer and Boyer (1995: 136-137) cite a study by Mengel and Barber where there was a steady increase in

root density and mass until pollination. After that point, roots began to die more quickly than they were produced, resulting in a decrease in root density and mass.

The length of time from the emergence of the first shoots from the soil until maturity is about 125 days and it normally takes 10-20 days for the first shoots to emerge from the soil after planting (Ritchie and others, 1997: WWWeb).

The water mass fraction of the roots and shoots are other parameters of interest. Gavloski and others (1992: 365-366) found that about 85 percent of the mass fraction of the shoots, and about 80 percent mass fraction of the roots, is water 71 days after emergence. Kramer and Boyer (1995: 20) cited a study by Miller that found corn leaves to be 77 percent water by mass at maturity.

There have also been models constructed that simulate the growth and development of maize. The most notable of these is the Crop-Environment Resource Synthesis (CERES) Maize model that was coordinated by Dr. J.T. Ritchie of the United States Department of Agriculture, Agricultural Research Service (USDA-ARS) (Jones and Kiniry, 1986: x). This model considers the independent and interacting effects of genotype, weather, hydrology, and nitrogen nutrition on the growth and development of maize. It appears to be the model that is most widely accepted in literature as the standard for simulating maize growth and development.

Uptake and Translocation of Lead

This discussion will focus on Pb^{2+} since it appears, as was previously discussed, to be the dominant form of soluble Pb in most natural systems that is taken up by plants.

The first step in determining how much Pb a plant will take into its roots is

determining how much Pb is bioavailable, which is the amount of Pb in soil solution. In order to take up this Pb, it must be in contact with the surface of the root. In order for a plant root to come in contact with Pb in the soil the root must either grow to reach the Pb or the Pb must be delivered to the root (Mengel and Kirkby, 1987: 66-67). In the first phenomena, called root interception, the roots come in contact with Pb as they push their way through the soil. It has been shown that the portion of essential nutrients, such as potassium, that a plant comes in contact with in this manner is small (Mengel and Kirkby, 1987: 67). The second phenomenon, where the Pb is delivered to the plant root, occurs through the processes of mass flow and diffusion. These processes account for the vast majority of ions that come in contact with the root surface (Mengel and Kirkby, 1987: 67). Mass flow occurs when water is absorbed by roots to meet plant water loss due to transpiration from the shoots (Gregory, 1988: 155). As the water moves to the roots dissolved ions are also carried to the root surface. Diffusion occurs when ions move along a concentration gradient established between the root surface and the body of the soil. Ions diffuse towards the root if they are taken up faster than they are carried to the surface by mass flow and diffuse away from the root if the reverse holds true. When transpiration is low, diffusion is usually the dominant process. When high concentrations of ions are present in solution and transpiration is high, mass flow may play the dominant role (Mengel and Kirkby, 1987: 69). In general mass flow and diffusion can be considered as additive processes (Gregory, 1988: 159).

After Pb is delivered to the root surface, it may then be taken into the symplast by the plant through the plasmalemma, move through the apoplast at the root surface, or

move internally into the apoplast of the cortex (Kochian, 1991: 241). This internal apoplast in the root cortex is sometimes referred to as the free space and can account for about 10 percent of the total volume of young roots (Marschner, 1986: 9 and Lindstrom and others, 1991: 130). The free space is generally accessible to ions such as Pb^{2+} and low-molecular-weight organic solutes, but is not accessible to high-molecular-weight solutes such as Pb-chelate complexes (Marschner, 1986: 10). The free space has a high binding capacity for cations and can increase the concentration of Pb^{2+} in the vicinity of the uptake sites at the plasmalemma (Marschner, 1986: 11). However, as Tyler and others (1989: 206) have noted, this binding capacity may in fact work to immobilize Pb outside of the plant tissue and may be a key reaction in reducing the toxicity of the Pb^{2+} ion. In any case, it is uncertain whether the epidermis, or the free space in the cortex, is more important in the uptake of Pb into plant cells. At low concentrations, it is likely that uptake at the epidermis plays the more important role (Kochian, 1991: 244).

Another phenomenon that takes place within the root, beginning at the epidermis and free space, but apparently occurring throughout the entire plant, that affects the uptake and translocation of Pb is the formation of insoluble Pb complexes (Malone and others, 1974: 388 and Tiffin, 1975: 327). Lead precipitate complexes have been found to form on the epidermis of the root and in the cell walls throughout the root. These insoluble complexes are not only confined to the root surface and free space, but have also been found in the stele, the stem, and leaves of plants such as maize and wheat (Malone and others, 1974: 388 and Tiffin, 1975: 327). In virtually all cases where these deposits have been studied they have been found to be in amorphous form, and in maize

these deposits were identified as Pb-phosphate complexes (Koeppel, 1977: 200 and University of Illinois, 1972: 210).

It appears that Pb-carbonates may be another form of Pb-precipitate found in plants (Kumar and others, 1995: 1237, Cunningham and others, 1997, and Cunningham, 1997: personal communication). Cunningham (1997: personal communication) believes that Pb-carbonates are the dominant form of precipitates in plants rather than Pb-phosphates. This is because bicarbonate is more likely to be available for complexation while phosphates are more likely to be bound.

At the root epidermis substantial deposits of Pb-precipitate appear to form quickly (Malone and others 1974: 388). The deposits internal to the root and all other parts of the plant form in a slightly different fashion. Using maize as a study plant, Malone and others (1974: 391) were able to identify Pb being precipitated in cytoplasm vesicles of all types of cells throughout the plant. These vesicles, which have a high phosphate content, would then form a membrane around the Pb deposit, gradually move the Pb-precipitate to the plasmalemma, and then fuse the deposit with the cell wall. More of these deposits were present in roots than stems, and more in stems than leaves. This led the author to postulate that Pb appeared to be mobile in the symplast until it encountered a sink, such as the vesicles. This would leave only Pb that is not precipitated on the root epidermis, or in the root free space or symplast, free to translocate to the shoots.

Research conducted by Clarkson and Luttge (1989: 93) with essential heavy metals such as cobalt, supports the notion that divalent cations such as Pb would have low solubility in the symplast and could easily form Pb-phosphate complexes that would

precipitate. Research conducted by Broyer and others (1972: 301-313) with barley plants suggests that of the Pb taken up by the roots, about 75 percent is associated either with the free space or the epidermis of the root, as it can be removed from the root using dilute acid or EDTA. However, research conducted by Huang and Cunningham (1996: 77-78) suggests that this fraction is substantially lower with maize.

The endodermis acts as an effective block to water and solutes moving from the apoplast to the stele (Marschner, 1986: 60, Kochian, 1991: 241-242, and Glass, 1989: 62). Following from this is a concept that appears to be well accepted in the literature -- that for solutes such as Pb to gain access to the stele, and subsequently to be loaded into the xylem, they must follow a pathway through the symplast such as that shown in Figure 10. Furthermore, for Pb to pass into the symplast it must first cross the plasmalemma of a living cell.

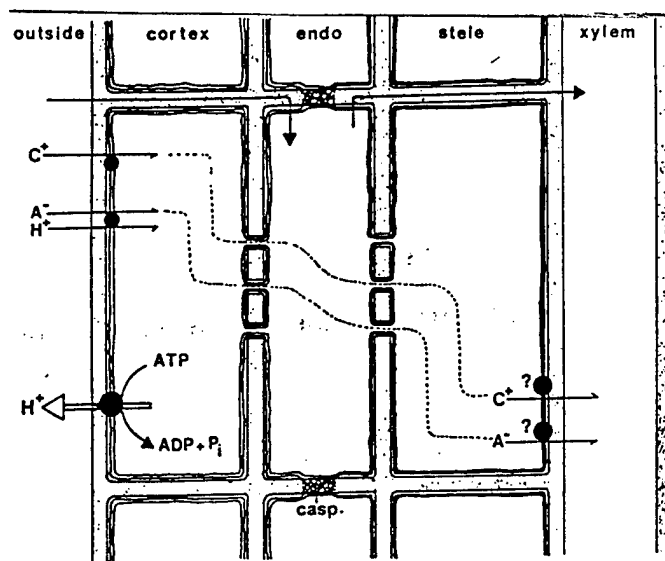

Figure 10 - Pathway of water and solutes into the stele and xylem (Kochian, 1991: 242)

Cell membranes are effective barriers to the passage of ions and uncharged molecules. On the other hand, they are also known to be selective in their uptake, concentrating essential elements to a much higher level than may be found in the external solution (Marschner, 1986: 19). This selectivity has led to the carrier hypothesis that there are carrier molecules in a plasmalemma that selectively bind ions and molecules enabling them to cross to the interior of a cell. Most researchers agree that these carriers are proteins (Nobel, 1991: 157). Alternatively, substances may move across a plasmalemma through pores or channels, which may be membrane-spanning proteins. Such channels could have a series of binding sites, where the ion or molecule goes from site to site through the plasmalemma (Nobel, 1991: 157). Figure 11 shows how these carriers may work. This hypothesis appears to be widely accepted in the literature.

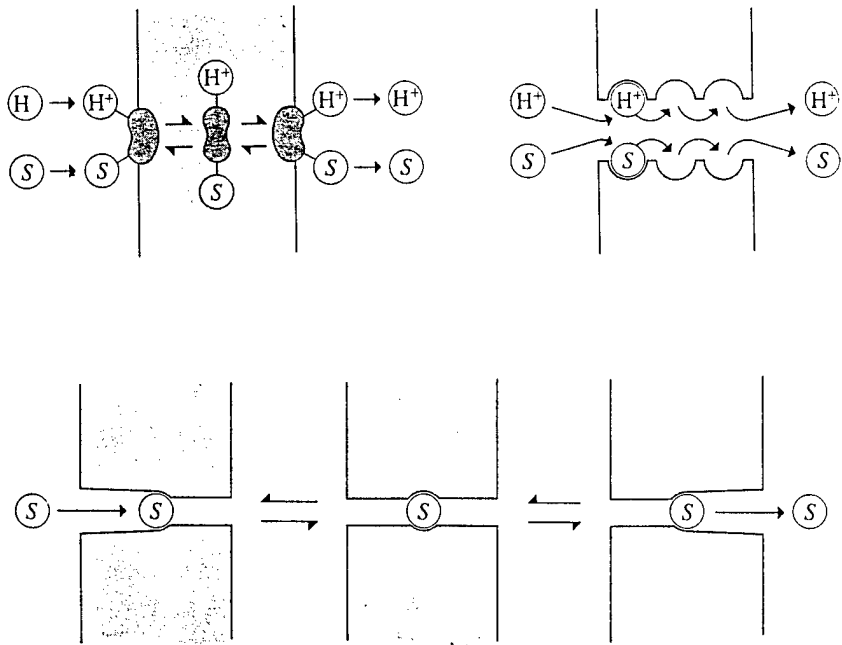

Figure 11 – Carriers and channels enabling solute crossing of the plasmalemma (Nobel, 1991: 158)

Competition for these binding sites also appears to occur between different elements. For example, zinc (Zn) absorption is inhibited by copper (Cu) and the hydrogen (H) ion, but not by iron (Fe) or manganese (Mn) (Alloway, 1990: 21). Copper absorption is inhibited by Zn, calcium (Ca), and potassium (K). Competition between ions of the same electrical charge and the similar size for these carriers or channels can be particularly strong (Marschner, 1986: 37). Since Pb is not an essential element, it must use carriers that are normally used by essential nutrients. Lead appears to compete with Ca in particular for these carriers (Huang and others, 1997). In a separate article, Huang and Cunningham (1996: 82) postulated that Pb could block Ca channels. They also noted (1996: 79) that Mn, Fe, Zn, K, Ca, and magnesium uptake were significantly decreased with increased Pb uptake, as were the total cations that accumulated in the shoots of both maize and ragweed.

The rate at which ions are taken up from soil solution into the symplast of plant roots appears to be controlled by saturation kinetics, due to a limited number of channels or carriers available for transport of ions into the roots (Marschner, 1986: 22). Uptake increases rapidly initially as the ionic concentration in solution increases, but as the carriers/channels through a cell membrane become saturated, the rate of increases gradually slows until it reaches some limit where all of the carriers are saturated. If solution concentration is increased further, there will be no increase in uptake because all of the carriers or channels are occupied. Epstein and Hagen regarded the kinetics of ion transport through the plasmalemma of a cell to be equivalent to the relationship between an enzyme and its substrate, using terms from enzymology (Epstein and Hagen as cited

by Marschner, 1986: 22 and Epstein in Salisbury and Ross, 1992: 150-152). The process of uptake has therefore been compared to Michaelis-Menten kinetics and is characterized by the equation: $U = (V_{max} * C) / (K_m + C)$

U = rate of uptake

V_{max} = maximal uptake rate. It is based upon the number of binding sites (carriers or channels) per unit mass available for uptake of the nutrient (Marschner, 1986: 51).

K_m = half saturation constant. The solution concentration where uptake is half maximal. The lower the K_m value, the greater the affinity for the given solute, whereas the higher the K_m value, the lower the affinity for the given solute (Marschner, 1986: 51).

C = the solution concentration at the root surface/root cortex apoplast (RCA)

Figure 12 shows how the maximum uptake rate (V_{max}) and the affinity would be greater (lower K_m) for an essential nutrient such as K than for a nonessential one like Na.

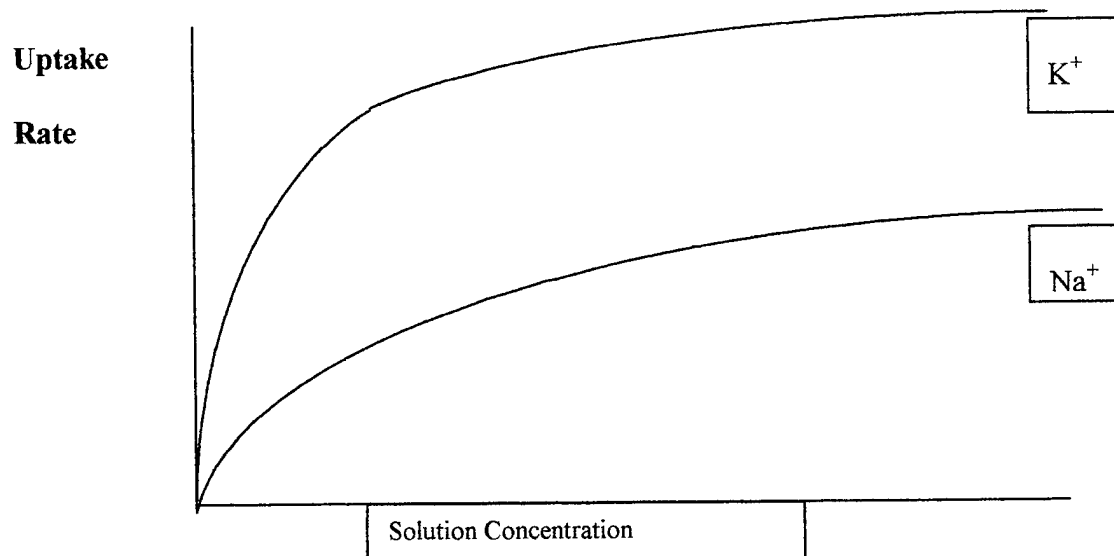

Figure 12 – Typical Michaelis-Menten Uptake Curves for Na and K

The Michaelis-Menten characterization of uptake rates appears to be widely

accepted in the literature. However, there are several anomalies that have been discovered when this has been used. One of these is that the values for V_{max} and K_m may vary considerably for a given plant depending upon its age or nutritional status (Marschner, 1986: 23 and Mengel and Kirkby, 1987: 145). For example, experiments have shown that over longer time periods V_{max} values are lower than V_{max} values for shorter duration experiments (Marschner, 1986: 49-50). It has been postulated that this variation may be caused by self-regulating mechanisms within plants for essential nutrients. When luxury uptake of nutrients occurs, a plant's internal concentration of the nutrient rises. As it rises, the plant seeks to counteract the potential negative effects of the excess internal concentrations by lowering its uptake, thus the drop in V_{max} and K_m values (Marschner, 1986: 49-50). This self-regulating mechanism has been postulated only for essential ions such as K. Since Pb is not an essential element, this mechanism may not be applicable for regulating its uptake (Haque and Subramanian, 1982: 53).

Another anomaly is that uptake may be multiphasic, or there may be multiple uptake mechanisms for a given ion (Nissen, 1996: 513). In other words, at different concentrations there are different values for K_m and V_{max} . As solution concentration increases, these parameters tend to increase, resulting in greater uptake rates (Nissen, 1973: 541-548, Nissen, 1996: 514-520, and Salisbury and Ross, 1992: 153). Figure 13 demonstrates this phenomena that appears to apply to both essential and nonessential ions in a wide variety of plants including maize (Salisbury and Ross, 1992: 153). Nissen (1996: 512) strongly supports the position that this type of behavior is caused by a single polypeptide that mediates uptake, and that this polypeptide has different conformational

structures at different external solution concentrations causing multiple phases of uptake (Nissen, 1996: 521). Other researchers have proposed that there may be two mechanisms that mediate transport -- a low-affinity mechanism and a high-affinity mechanism (Nissen, 1996: 514). Still others have proposed that the anomalies may be due to experimental error or that there is both a saturable and a linear component to uptake (Nissen, 1996: 513-515).

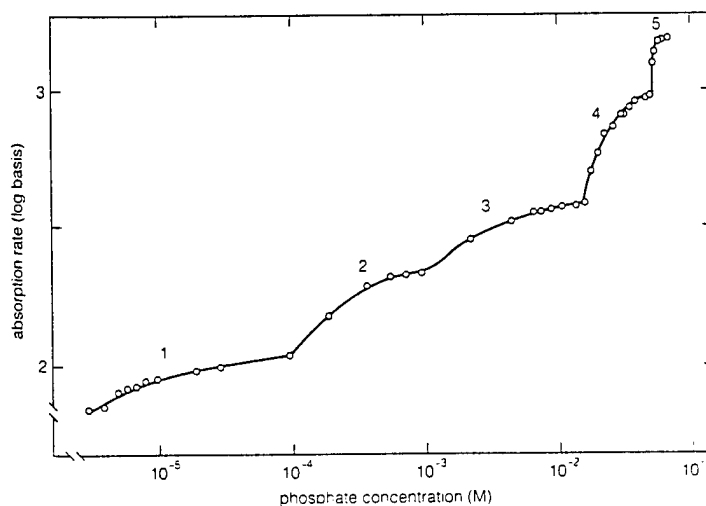

Figure 13 – Multiphasic Uptake Kinetics (Salisbury and Ross: 153)

These mechanisms have been postulated based upon extensive experimental research with essential nutrients. Since Pb is not an essential nutrient, and since there appears to be little if any research into this phenomenon with Pb, it is difficult to predict whether a plant's response in Pb uptake would be similar.

Once inside the symplast, Pb is likely to do one of several things. First, Pb²⁺ may bind with the sulphhydryl (-SH) groups of peptides. This binding is the basis for toxic effects within plants (Alloway, 1990: 25 and Clarkson and Luttge, 1989: 105). Second, it

may bind with phytochelatins (Kinnersley, 1993: 211). Phytochelatins are small, cysteine-rich peptides that are biosynthesized by plants exposed to heavy metal stress. These phytochelatins appear to function by complexing with and detoxifying heavy metals within plant cells. Third, Pb may precipitate as Pb-phosphate or carbonate. As previously discussed, this precipitate is likely to be an amorphous Pb-phosphate in maize, and appears to concentrate in vesicles in the cytoplasm of a cell. Once Pb is precipitated, it is moved to the cell wall and fuses with it (Malone and others, 1974: 388 and Koeppel, 1977: 200-202). Lead may also move through the root symplast to the xylem and be translocated to the shoots in the transpiration stream (Marschner, 1986: 63)

The rate at which Pb is loaded into the xylem appears to be restricted only by the rate at which Pb can move through the plasmodesmata that cross the endodermis (Forbes and Watson, 1992: 71). This movement of Pb most likely occurs in a manner similar to other ions, along with the water flow through the symplast. It appears that the movement of ions through the endodermis may be a rate-limiting step in the translocation from the root to the shoots (Salt and others, 1995: 471). This is because up to the endodermis, Pb can move through the apoplast. Once it reaches the endodermis its movement is blocked and it must enter into the symplast before it can cross into the stele and reach the xylem.

Having passed into the stele, Pb is then loaded into the xylem. The process by which solutes are loaded into the xylem is highly uncertain. The process may be passive, where solutes simply leak into xylem due to a diffusion gradient (Lauchli and Bielecki, 1983: 194). However, other research has suggested that loading of ions into the xylem may be an active transport process (Kochian, 1991: 345-347 and Lauchli and Bielecki,

1983: 194-195). Since this process occurs internal to the plant, it is not easy to study and remains uncertain.

Once the Pb enters the xylem it may be transported to the shoots in the transpiration stream (Salisbury and Ross, 1992: 82). The process of Pb transport in the xylem can be characterized by mass flow (Kochian, 1991: 247, Marschner, 1986: 73, and Mengel and Kirkby, 1987: 212). However, the process of cation movement through the xylem may be different than that of water movement. Xylem cell walls have a high cation exchange capacity (Raskin and others, 1994: 287, Salt and others, 1995: 471, and Marschner, 1986: 73), and therefore cations may be adsorbed to cell wall surfaces and exchanged for other cations (Mengel and Kirkby, 1983: 212, Marschner, 1986: 73, and (Kochian, 1991:248). This adsorption may retard the movement of cations in the xylem, though there is some disagreement concerning this matter.

Marschner (1986: 73) has proposed that the movement of cations in the xylem can be compared to movement in a cation exchanger with a decline in cation translocation rates in comparison to the flow of water. The degree of retardation depends on the valency of the cation ($2+ > 1+$), its concentration and activity, the presence of competing cations and complexing agents, the charge density of the negative groups, the diameter of the xylem vessels, and the pH. Salt and others (1995: 471) and Raskin and others (1994: 287) also support the view that the movement of metal cations may be severely retarded in the xylem due to this adsorption. They base their views on the work of Senden and others (1993: 71) that suggests that Cd^{2+} movement in the xylem of tomato plants may be retarded in comparison to Cd that is chelated with citric acid.

It appears that this retardation may be a factor with Pb in some plants. For example, Cunningham and others (1995: 45) found that most of Pb that is translocated to the shoots is sequestered in the lower stem for common ragweed (*Ambrosia artemisiifolia*), Asiatic dayflower (*Commelina communis*), and hemp dogbane (*Apocynum cannabinum*). Tiffin cited Taylor (1975: 327) as having similar findings in alfalfa (*Medicago sativa*). However, Kabata-Pendias and Pendias (1992: 193), Baumhardt and Welch (1972: 93), and Huang and others (1996) all found that Pb concentrations were either equal, or slightly higher, in maize leaves than stems.

Kochian (1991: 248) disagrees with the above researchers on retardation. He believes that the concentration of Ca^{2+} is usually high enough that the cell wall cation-binding sites should be saturated with Ca^{2+} . Thus, the movement of other cations such as Pb^{2+} would not be significantly hindered.

It is also possible that Pb may not be translocated in the xylem as a cation, but may be translocated as a neutral Pb-chelate complex. Clarkson and Luttge (1989: 105) cite a number of studies showing that Cu, Zn, Ni and Cd, exist in the xylem sap and within plant cells primarily in complexed forms which are neutral. However, this is not the case for Mn. Foy and others (1978: 540) believe that Pb may be transported in the xylem as a Pb-chelate complex, with the chelators being organic and amino acids (Foy and others, 1978: 540). If Pb is transported in the xylem as a neutral Pb complex, movement would not be retarded by the cation exchange process.

As essential minerals ascend in the transpiration stream, they are also dispersed throughout it (Forbes and Watson, 1992: 72). The xylem is similar to a collection of

porous pipes from which minerals may leak into the apoplast of the surrounding tissue at any point along its length. From the apoplast, or from the xylem itself, minerals may be absorbed into the symplast of adjacent living tissue. On the other hand, if concentrations in the tissue are higher than in the xylem, minerals may be reabsorbed back into the xylem (Lauchli and Bieleski, 1983: 196-197 and Marschner, 1986: 74-75). Minerals that travel all the way to the leaf in the xylem may remain in the leaf apoplast or may be absorbed by the symplast of leaf cells. In the leaf, they may be used, stored, or may be re-exported in the phloem out of the leaf. These processes that occur with essential minerals may happen in an analogous manner for Pb.

From the roots to the shoots there is also an exchange of solutes between the xylem and the phloem, with this transfer being most pronounced in the stem (Marschner, 1986: 88-89). Experimental evidence suggests that the transfer of minerals from the xylem to the phloem is an active transport process, and that this transfer process plays an important part in the mineral nutrition of plants. It also appears that transfer of minerals from the phloem to the xylem could occur passively through diffusion. However, evidence to support this assertion is scant. It appears that for some essential minerals, such as P and Mg, this process does occur, but not for others such as K.

Movement of Pb in the xylem most likely occurs in a similar manner to that of the essential minerals (Raskin and others, 1994: 287 and Salt and others, 1995: 471). There is strong evidence that Pb is transported in the xylem to the shoots (Huang and others, 1997: 803). Once Pb reaches the shoots, it likely precipitates as a Pb-phosphate in a manner similar to that which occurs in the roots (Malone and others, 1974: 391).

Whether or not Pb is transported into the phloem at all, as described above for essential minerals, is an issue of considerable uncertainty.

Essential minerals in a plant vary greatly in the degree to which they are transported in the phloem. Potassium, rubidium, and Mg are all highly mobile in the phloem, Zn, Cu, and Fe are transported to a lesser degree, and Ca is very immobile (Marschner, 1986: 86). All minerals that move within the phloem appear to move according to the Munch hypothesis. According to this hypothesis solutes within the phloem are carried from source to sink – moving from areas of high concentration to low concentration in the plant. This means that mineral flow within the phloem is bidirectional, in contrast to the unidirectional flow of the xylem (Salisbury and Ross, 1992: 164-183, Kochian, 1991: 249 and Marschner, 1986: 87). The sources of mineral elements in a plant are: the apoplast of the stele in the roots; the xylem in the stem and leaves; and the tissue of old leaves. The sinks are the young parts of the shoots – new leaves, stem tissue, and fruit or seeds (Marschner, 1986: 87 and Kochian, 1991: 249). Since the root is a source for minerals, it has been suggested that minerals may be transported to the shoots in the phloem (Pitman and Cram, 1973: 465). The experimental evidence that is available however, suggests that little if any minerals are transported in this manner (Marschner, 1986: 91).

A good indication of the phloem mobility of a mineral is the difference in concentration between sources and sinks of that mineral. If a mineral is mobile in the phloem, tissue concentrations should be equal to or higher in the sinks (young leaves, seeds, ears) than tissue concentrations in the sources (old leaves). On the other hand, if

the mineral is immobile in the phloem, just the opposite should be expected. This is what occurs in plants with Ca, which is considered to be very immobile in the phloem (Marschner, 1983: 27-28).

Another good indicator of the phloem mobility of a mineral is the distribution of minerals compared to transpiration. If a mineral is only mobile in the xylem, there should be a distinct distribution pattern in the organs that reflect the transpiration rates and the duration of transpiration (Marschner, 1986: 80). Silicon (Si) is a good example of this, as the Si content of leaves increases distinctly with leaf age. Additionally, organs that transpire greater amounts of water should also have higher mineral concentrations compared to organs that transpire less water. Therefore, organs such as seeds and fruit should have much lower concentrations of minerals compared to mature leaves (Lauchli and Bielecki, 1983: 19).

It has been shown that metals in general, though not Pb specifically, can be redistributed in a plant via the phloem (Clarkson and Luttge, 1989: 104). Nicotianamine has been shown to be involved in the transport of Fe, Zn, Cu, Ni, and Co in the phloem, though not of Pb (Stephan and Scholz, 1993: 523). Pb can complex with phytochelatins as previously discussed. Since there is evidence that phytochelatins are transported in the phloem, if Pb is chelated in this manner, it is possible that it may be transported in the phloem (Blaylock, 1997: personal communication). On the other hand, others have asserted that translocation of Pb in the phloem appears to be very limited (Huang, 1997: personal communication and Blaylock, 1997: personal communication). This assertion is supported by experimental data that shows much lower accumulation of Pb in parts of

plants that are primarily supplied by the phloem. The ear of a maize accumulates much lower concentrations of Pb compared to the other parts of the shoots (Baumhardt and Welch, 1972: 93), and old leaves have been shown to have Pb concentrations that are about twice as high as concentrations in young leaves (Koeppel, 1977: 198). Additionally, Malone and others (1974: 391) found precipitated Pb-complexes in the cell walls of nearly every type of cell in maize except for cells associated with the phloem. Finally, even if Pb is transported into the phloem, it is likely that it would rapidly precipitate due to the presence of high levels of phosphate in the phloem sap (Hughes and others, 1980: 277). It therefore appears that the literature supports the notion that Pb is transported little, if any, in the phloem.

Research conducted by Huang and Cunningham (1996: 75-84) provides some time-dependent data on uptake and translocation of Pb that may offer clues about how plant mechanisms work together to affect plant accumulations. Their experiment was conducted on maize seedlings that were initially grown in nutrient solution for two weeks without any Pb. Subsequently, Pb was added as $\text{Pb}(\text{NO}_3)_2$ to the solution at a concentration of 20 micromolar (approximately 4 milligrams per liter). The plants were then grown for 28 days in this solution, and samples taken at day 7, 14, 21, and 28 to determine Pb uptake. Lead concentration in the plants increased rapidly in the first week, increased slightly in the second week, and leveled off reaching a steady state after two weeks in both the roots and the shoots.

The work of Kumar and others (1995: 1232-1238) in their research with Indian mustard (*Brassica juncea*) produced results that appear to be similar. Plants in this

experiment were grown in a hydroponic medium for 17 days before Pb was added to the solution as $\text{Pb}(\text{NO}_3)_2$. Subsequent to the addition of Pb, the plants were grown for 14 days and samples of the plants were taken during this time frame. It appeared that concentrations in the plant were beginning to level off after this period.

In summary then, Pb appears to be taken up into the roots of a plant if it is bioavailable. However, only a small percentage of the Pb that is taken into the roots is usually translocated to the shoots. Table 1 lists the experimental results of Huang and Cunningham (1996: 80) with 12 different types of plants concerning the uptake and translocation of Pb from both nutrient solution and soil. The uptake and translocation of Pb varies considerably, with even the most efficient accumulator (maize) translocating only about 20 percent of the Pb taken into its roots to the shoots. Additionally, the concentration of Pb in the maize shoots at 0.02 percent is about two orders of magnitude less than the required accumulation efficiency of 1-3 percent needed to make phytoextraction a viable remediation strategy. The experimental results of Huang and Cunningham are representative of other results found in the literature that show little Pb translocation from the roots to the shoots.

Plant Species	Nutrient Solution		Soil Experiment	
	Shoots	Roots	Shoots	Roots
Zea Mays (v. Fiesta)	375	2280	225	1250
<i>Brassica juncea</i> (211000)	347	14500	129	2390
<i>Brassica juncea</i> (426308)	329	6650	ND	ND
<i>Brassica juncea</i> (531268)	241	19500	97	3460
<i>Thalspi rotundifolium</i>	226	28700	79	6350
<i>Brassica juncea</i> (175607)	176	18200	ND	ND
<i>Triticum aestivum</i> (cv. Scout 66)	139	5330	120	1890
<i>Ambrosia artemisifolia</i>	95	4670	75	2050
<i>Brassica juncea</i> Czern	65	9580	45	3580
<i>Thalspi caerulescens</i>	64	26200	58	5010
<i>Brassica juncea</i> (180269)	59	4840	ND	ND
<i>Brassica juncea</i> (184290)	32	5260	30	2310

ND means no data because plant did not survive.

Table 1 - Lead Concentrations in Various Plants from Soil and Nutrient Solution Experiment (Huang and Cunningham, 1996: 80)

Uptake and Translocation of Lead-Chelates

The use of synthetic chelators, such as EDTA, has greatly improved the prospects of phytoextraction becoming a viable technology in the near future. This is because plants appear to uptake and translocate Pb-chelates much more readily than Pb. In this section, the differences between uptake and translocation of Pb and Pb-chelates in general, but primarily Pb-EDTA, will be discussed.

There have been several notable studies conducted concerning the uptake and translocation of Pb-chelates by the following researchers: Crowdy and Tanton (1970:

102-111), Malone and others (1974: 388-394), Huang and Cunningham (1996: 75-83), Huang and others (1997: 800-805), and Blaylock and others (1997: 860-865). The purposes and methods of the researchers were various. Crowdy and Tanton's (1970: 103-104) purpose was to locate the free space in plant tissue in regards to water movement, and their study plant was wheat seedlings. Malone and others (1974: 388) purpose was to study the localization of accumulated Pb and characterize the method of accumulation as specifically as possible. Their study plant was maize. The other three groups all had phytoextraction as their study purpose, but they had other differences in their research. Huang and Cunningham (1996: 76) and Huang and others (1997: 801) both used HEDTA as their chelator, with the former using maize as their study plant while the latter used both maize and pea. Blaylock and others (1997: 861) used several different chelators, but focused primarily on EDTA and used *Brassica juncea* (Indian mustard) as their study plant. Despite these differences, there are many insights that can be gathered about the uptake and translocation of Pb-chelates from these studies.

The first item of interest in these studies is the surge in Pb concentration in soil solution that occurred after the application of chelates. In all three of the phytoextraction studies, Pb in soil solution increased dramatically with the application of chelators (Huang and Cunningham, 1996: 81, Huang and others, 1997: 802, and Blaylock and others, 1997: 861). The dramatic increases in soil solution Pb concentration corresponded with dramatic increases in Pb concentrations in the plants (Huang and Cunningham, 1996: 81, Huang and others, 1997: 803, and Blaylock and others, 1997: 861). In the study done by Huang and others (1997: 803), there was also a very strong

linear correlation noted ($r^2 = 0.98$) between the Pb in soil solution and the Pb in the shoots of the plant. As noted earlier, Pb concentrations in soil solution are usually very low because Pb precipitates as Pb-phosphates, carbonates, and hydroxides in soil, and binds to clays and organic matter. The dramatic increases in soil solution Pb appear to be caused by the chelators, as they interfere with the precipitation and binding that normally occurs in soil (Huang and others, 1997: 804).

Once the Pb-chelate is dissolved in soil solution, the question arises as to how it is absorbed into root. Is the Pb taken up as a Pb-chelate complex or is the chelator removed from the Pb before it is absorbed? The answer to this question is uncertain.

Some literature suggests that metal-synthetic chelate complexes are not taken up by plants, though none specifically addresses Pb. Huang and others (1997: 804) make the comment that the general belief in plant nutrition is that plants do not absorb or translocate synthetic chelates or the complex of ion and synthetic chelate, citing Kochian (1991) and Marschner (1986). Blaylock and others (1997: 864) make a similar general comment. Kochian (1991: 252, 263, and 267) does in fact state that it appears that plants do not take up Fe, Mn, and Cu as ion-synthetic chelate complexes, but instead separate the ion from the chelate at the root surface before uptake. He does not discuss the possible uptake of Pb-synthetic chelate complexes. Marschner (1986: 55) also discusses how the Fe ion appears to be separated from synthetic chelators before uptake, as does Tiffin (1975: 320). Marschner (1986: 11-12) also discusses how Zn-EDTA appears to be taken up by plants, though at a lower rate than the free ion. Neither Tiffin nor Marschner discuss uptake of Pb-synthetic chelate complexes. Clarkson and Luttge (1989: 95) cite

research that shows how introducing EDTA to increase chemical concentrations of Cd, Zn, and Mn in solution did not increase uptake of these metals, and that uptake depended only on the activity of the free divalent cation. For Cu, an increase of four orders of magnitude in the presence of EDTA only increased Cu uptake by 30 percent. Foy and others (1978: 539) cite several studies that show that chelators added to nutrient solution reduce metal activity and metal uptake dramatically, though Pb is not directly addressed.

Some of the general conclusions that Wallace reached in his three decades of research concerning synthetic chelating agents also provide some good insights (Wallace, 1983: 426-427). He concludes that chelating agents, to an extent, can be taken into plant roots and transported to the leaves of plants. These agents seem to enter, at least in part, through broken roots or when the root has been otherwise injured. Cunningham (1997: personal communication) supports this assertion, and believes that high levels of EDTA may actually cause breaks in the endodermis to occur. Wallace also states that metal-synthetic chelate complexes appear to give some characteristics of metabolic uptake. Finally, in the case of Fe-synthetic chelate complexes, he asserts that much more Fe than chelate is taken up by plants.

There is also some solid evidence that Pb-synthetic chelate complexes are taken up by plants. In Crowdy and Tanton's study (1970: 109), Pb and EDTA were both identified in plant cell walls when Pb-EDTA was supplied to wheat seedlings in nutrient solution. The research by Malone and others (1974: 388), Huang and others (1997: 804), and Blaylock and others (1997: 864) strongly suggests that Pb is taken up as a Pb-synthetic chelate complex. The most convincing evidence in these three studies is from

Huang and others (1997: 804), where a synthetic chelator was dyed purple, and a purple color could be observed in the leaves of plants within 12 hours of the addition of the synthetic chelate. Finally, Salt states that recent experiments at his lab clearly show that Pb-EDTA moves from the roots to the shoots as Pb-EDTA complexes (Salt, 1997: personal correspondence). Taken as a whole, the literature seems to support the position that Pb is taken up as a Pb-synthetic chelate complex. The mechanism for Pb-chelate uptake would almost certainly be different than the ion carrier/channel mechanism that was previously discussed for Pb^{2+} .

At the root surface and root cortex apoplast (RCA) there may be other differences that significantly impact uptake of Pb-synthetic chelate complexes. On the negative side, these complexes may be too large to enter the free space in the RCA, thus significantly lowering the number of possible uptake sites into the root symplast (Marschner, 1986: 10). Wallace has concluded that an excess of chelating agents in solution can inhibit uptake of cations by roots (Wallace, 1983: 426). He speculates that this may be due to competition between chelating agent and the binding site on the root. If the Pb-synthetic chelate complex is neutral or negative in charge there would be little or no binding to the root surface like there is with Pb^{2+} . This would mean relatively lower Pb concentration in the vicinity of uptake sites that could reduce uptake. This appeared to be the case experimentally with Zn^{2+} and Zn-EDTA (Marschner, 1986: 11-12). Malone and others (1974: 388) also found that Pb-EDTA supplied in nutrient solution to maize does not form precipitates on the root surface, while Pb supplied in other forms readily precipitates there. This lack of precipitation at the root surface may enhance Pb uptake.

No explanation has yet been offered in the literature as to the mechanism by which Pb-synthetic chelate complexes are taken up into the symplast, if in fact they are taken up there. Cunningham (197: personal communication) has speculated, in agreement with Wallace (1983: 426-427), that these complexes may enter plant roots through breaks in the Casparian strip. If this is the case, these complexes could then be transported to the shoots without ever entering the symplast.

Transpiration appears to have a strong influence on the amount of Pb-chelate that is taken into plant roots and translocated to the shoots. Crowdy and Tanton (1970: 105) found that there was a strong linear correlation between transpiration and lead accumulation. Blaylock and others (1997: 864) discovered that placing a plant near a fan increased uptake of Pb-EDTA by 30 percent, while covering the plant with a plastic bag reduces Pb-EDTA uptake by 35 percent. They speculated that the variation in uptake in these cases was due to variations in transpiration.

Lead-synthetic chelate complexes appear to be translocated much differently than other forms of Pb. Huang and Cunningham (1996: 81), Huang and others (1997: 802), and Blaylock and others (1997: 863) all found that Pb translocation from root to shoots is greatly enhanced when synthetic chelators are used. This enhanced translocation may be related to the decreased cell wall binding of Pb in the roots of the plant (Blaylock and others, 1997: 864) or of enhanced translocation in the xylem. The experimental results of Huang and others (1997: 803) showed that Pb-EDTA increased the concentration of Pb in the xylem sap between 46 and 140 fold. Crowdy and Tanton (1970: 109) also found large quantities of Pb in the xylem vessels. Cunningham (1997: personal

communication) has speculated that Pb-EDTA may be transported in the xylem as a negatively charged complex. This could enhance movement in the xylem because movement would not be retarded by the cation exchange process, as it may be with Pb^{2+} . Huang and others (1997: 804) have also speculated that synthetic chelates at high concentrations may alter plant ion transport systems in an unknown manner that facilitates Pb uptake and translocation.

The surge in uptake and translocation of Pb in plants when synthetic chelators are supplied to the plant also has dramatic effects upon plant health. In Huang and Cunningham's research (1997: 81) one week after the plant was supplied with synthetic chelators the plants died. However, as the authors pointed out, plant death should not significantly interfere with harvesting the plants for the purpose of phytoextraction. Cunningham (1997: personal communication) has noted that plant death appears to be caused due to transpiration "closing down" as the Pb accumulates in the plant shoots. This assertion by Cunningham appears to be supported by Crowdy and Tanton's research (1970: 110), where Pb deposits were noted in the cell walls of plant leaves, but not in the living tissue. These types of deposits could interfere with plant transpiration.

In summary, the use of synthetic chelates appears to be a significant step forward in the field of phytoextraction, greatly increasing shoots Pb concentrations. Lead concentrations in maize were greater than one percent dry weight in studies by both Huang and Cunningham (1996: 81) and Huang and others (1997: 830) when synthetic chelators were applied to soil contaminated with Pb. These large concentrations of Pb cause death of the plants in a short time span. However, if the plants are allowed to grow

to sufficient size before chelators are applied, sufficient Pb should be accumulated in the shoots to make phytoextraction a viable remediation technology (Huang and others, 1997: 804, Huang and Cunningham, 1996: 82-83, and Blaylock and others, 1997: 864).

Models and Modeling

This section begins with some discussion on the various schools of thought concerning modeling. In the second section types of models that characterize the uptake of nutrients and heavy metals by plants are examined. The final section discusses three specific models of plant uptake of nutrients and heavy metals, one model that simulates the uptake and translocation of lead, and one that simulates the uptake and translocation of organic chemicals.

There are a number of different approaches to simulating the behavior of a system using computer models. Meadows (1980: 23) identifies five approaches to modeling: linear programming, input-output analysis, econometrics, stochastic simulation, and system dynamics. The general observations that he makes about these modeling approaches are: each approach has its distinct set of theories, mathematical techniques, languages, and accepted procedures for constructing and testing models; each approach has its own assumptions of how modeling should be done.

Meadows (1980: 28-29) also goes on to distinguish and discuss models based upon their use: general understanding, policy formulation, and detailed implementation. Models used for general understanding should be process-oriented. They should be used to identify causes and consequences of a problem. Quantitative precision in these models is not necessary and probably unattainable due to the poor understanding of the system.

These models should be used to define new concepts of how a system works. Models used for policy formulation should lead to suggestions about general directions for solutions to problems. These types of models should be able to reproduce real system behavior under a variety of conditions, should easily be altered to test a variety of policies, and should clarify why different policies lead to different results. Detailed implementation models should produce information that is detailed and highly accurate. Mathematical models are ideally suited for detailed implementation models.

Bell and Bell (1980: 12 and 17) also provide some insights into a school of thought on knowledge and modeling called instrumentalism. From this view, knowledge is gained by finding correlations with closer statistical fit to data. In this school of thought, models using empirical equations are widely used.

Many models that are used to simulate plant uptake of nutrients or heavy metals appear to coincide with the instrumentalism view, being primarily concerned with gaining the best statistical fit to observed data. Some of the other models of nutrient or heavy metal uptake appear to follow the linear programming or econometrics approach. Many of these models are also identified as mathematical models. However, classifying models of plant uptake of nutrients and heavy metals in a more appropriate manner appears to have been done by other researchers.

Rengel (1993: 161-173) has conducted an in-depth review of the models that simulate uptake of nutrients by plants. He classifies these models as either empirical, mechanistic, or nutrient –uptake balance models. Empirical models attempt to describe observed phenomena without hypothesizing how they happen. Mechanistic models seek

to explain how observed phenomena have happened. Nutrient-uptake balance models fall somewhere between the two other types of models describing a few of the relevant processes in mechanistic fashion while deriving most relationships from statistical data (1993: 161-162). He further asserts that mechanistic simulation models have proved to be a valuable resource in studying processes governing soil supply and plant uptake of essential nutrients (1993:162). Models that he has reviewed do not generally account for nutrient distribution in the plant and root-shoots interactions (1993: 162).

The key parameters in the models Rengel reviewed are described in terms of the soil or the plant. Soil parameters describe movement of nutrients to the root, either transpiration driven mass flow of soil solution, or by ion diffusion that depends on concentration gradients in soil solutions that are induced by depletion at the root surface (1993: 162). Plant parameters describe changes in root geometry and growth and the kinetics of nutrient uptake by the root (1993: 163). Kinetics are usually described by the Michaelis-Menten equation that has been previously discussed. Rengel (1996: 166) also emphasizes the importance of verifying the model with experimental data. This verification is usually accomplished by evaluating the statistical fit between model predictions and experimental data. Finally, he discusses how modeling uptake of only one ion at a time is a shortcoming of most of these models, and how the few models that do simulate uptake of more than one ion do not account for synergism or antagonism between the nutrients (1993: 167-168).

A second researcher who has conducted an in-depth review of plant uptake models of nutrients including some heavy metals is Silberbush (1996: 643-658). He

classifies these models as either empirical or mechanistic. The empirical models correlate soil nutrient availability with uptake and production by plants, but do not simulate uptake by plant roots (1996: 643). The mechanistic models simulate nutrient uptake from soil by roots. These mechanistic models are further classified as either one-dimensional vertical models or single-root models (1996: 643). One-dimensional models take into account differences along the vertical dimension of the soil profile, assuming uniform lateral distribution of all other factors (1996: 644). Silberbush believes that these models oversimplify the root system. Single-root models are a sub-category of one-dimensional models that improve uptake simulation by accounting for uptake by growing roots and by simulating flow to roots in the radial direction (1996: 647). Both the one-dimensional and single-root models use a form of the Michaelis-Menten equation to describe the kinetics of uptake (1996: 645 and 651).

Silberbush also cites several problems to be overcome in modeling of plant uptake of nutrients (1996: 653-654). The first problem is accounting for the environmental and physiological effects on root growth. The second problem is accounting for variations in root uptake due to root age, root hierarchy, or site along the root. The third problem is accounting for the effects of root exudates that can change pH in the root soil environment and chelate metals. The final problems are considering variations in soil conditions, root competition, and uptake of multiple ions by plant roots.

Three examples of models that simulate uptake of nutrients are examined in this paragraph. The first model was one that was developed by Gerritse and others (1983: 393-404). This model focuses on the correlation of metals found in plant tissue and the

solubility of metals in soils as determined by chemical extraction techniques. It does not discuss the causal mechanisms behind these correlations. Though this model was not specifically reviewed by either Rengel or Silberbush, both would almost certainly classify it as an empirical model. Claasen and Barber (1975: 358-364) developed what they termed a mathematical model to describe the uptake of metals by plants. The significant soil parameters in this model were: effective diffusion coefficient, soil buffering capacity, and concentration of the metal ion in soil solution (1975: 358). The significant plant parameters were: initial root length, root radius, rate of root growth, and relation between uptake rate and the metal concentration in solution at the root surface (1975: 358). The Michaelis-Menten equation was used to describe uptake kinetics. Using different parameter values, the model accurately predicted uptake of K from four different types of soils ($r^2 = 0.87$) (1975: 358), and is often referred to throughout the literature. This model was classified as a single-root mechanistic model by Silberbush (1996: 647), and a mechanistic model by Rengel (1993: 163). Rao and Mathur (1994: 89-96) constructed a model whose purpose was to predict the uptake of Cd taking into account macroscopic water flow and solute transport equations (1994: 90). They used eight equations to characterize the growth of the root and uptake of Cd (1994: 93). Among these equations was the Michaelis-Menten equation governing uptake kinetics. This model, perhaps less sophisticated than the one formulated by Claasen and Barber years earlier, was classified as a one-dimensional model by Silberbush (1996: 644).

In my review of the literature I found only two models that simulated both uptake and translocation by plants. The first was a crude model developed in 1972 that

described uptake and translocation of Pb. The second model was much more sophisticated and mechanistic, but it described uptake and translocation of organic solutes. These two models are discussed below. Nowhere in the literature was I able to find a model that mechanistically described uptake and translocation of Pb or other metals.

A model that was developed for the National Science Foundation by the University of Illinois (1972: 366-382) simulated uptake and translocation of Pb. The objective of the model was to determine the concentration of Pb in the various tissues of a selected plant at any time (1972: 366). The model was very simple. It assumed constant rates of partitioning between different plant compartments throughout the growing season. These rates of partitioning were then multiplied by the amount of Pb in each plant compartment at a given point in time to describe the flow of Pb from one compartment to the next (1972: 371-372). The utility of this model for gaining insights about uptake and translocation of Pb is limited, due to the lack of accounting for any feedback mechanisms, and the oversimplification of the process of translocation of Pb.

The final model to be reviewed is one that was developed by Lindstrom and others (1991: 129-136). The purpose of this model was to help explain experimental results and clarify physiological mechanisms in a plant (1991:129). It defines a plant as a set of compartments each representing pertinent plant tissues (1991: 129). Compartments are identified as the soil solution, root, stem and leaves. They are separated by boundaries, which are represented by effective diffusion path lengths and have specified thickness and area. Movement of water and solutes occurs by mass flow

and diffusion, and is restricted by tortuosity of the path, selective permeability, and partitioning between tissue compartments (1991: 129). Water moves along the xylem via gradients in water potential which are created by transpiration (1991: 130 and 136). It moves to storage volumes in adjoining cells via diffusion, and in the phloem driven by gradients in pressure potential. Solutes partition into storage compartments at rates determined by physical characteristics of the given chemical. Evaporation of both volatile contaminants and water occurs in the leaves (1991: 131). Connections between xylem and phloem occur in the leaf and root compartments.

This model appears to provide a reasonable simulation of a plant taking up and translocating organic chemicals. Its authors claim that the model adequately simulates experimental results (1991: 136). The model has two apparent weaknesses: it does not account for growth of the plant and it does not account for changes in the magnitude of different mechanisms and parameters due to feedback within the plant. In spite of these drawbacks, it provides some insights on plant uptake and translocation processes.

3. Methodology

As stated in Chapter One, the research questions that correspond to the research purpose are to be answered through the development and application of a model. In this chapter the choice of an appropriate modeling approach is examined. Subsequently, the methods for developing, testing, and applying the model to answer the research questions are presented. This chapter is broken into five sections: modeling approach, model development process, model conceptualization and formulation, model testing and validation, and model application. The modeling approach section examines which approach is to be used, and why it was chosen. The model development process section describes the process for developing a model from the modeling approach selected. The model conceptualization section explains how a reference mode was selected for this model and how it is used in model development. This section will also explain how the basic mechanisms of a system are derived and described, and how a system dynamics model is formulated from them. The next section discusses tests that are used to build confidence in and validate the model. The final section presents how the completed model may be applied to phytoextraction management situations.

Modeling Approach

Selection of a modeling approach first required examining the requirements of the model. This could best be accomplished by looking at the thesis purpose statement. After closely examining the purpose statement, it became clear that the model would have to lead to insights about the mechanisms controlling uptake of Pb and translocation

of Pb from the roots to the shoots. It would also have to lead to insights about how these mechanisms interact to affect behavior of the entire system. Therefore the model must seek to explain how uptake and translocation of Pb is occurring through the process of simulating the system. A model that accomplished these tasks would almost certainly be classified as mechanistic by either Rengel (1993: 161) or Silberbush (1996: 643). However, this model would have to go much farther than any of the models they had reviewed, since these models simulated uptake only and not translocation.

The process of uptake and translocation of nutrients is not well understood (refer to Kochian (1991: 230) for example). The process of uptake and translocation of Pb is even less well understood (refer to Huang and others (1997: 804), Blaylock and others (1997: 864), and Kumar and others (1995: 1235) for example). Given this, and the fact that there does not appear to be any models in the literature that mechanistically simulate the uptake and translocation of nutrients or heavy metals, the model needs to lead to a general understanding of the process of uptake and translocation of Pb. It would therefore be classified as a model of general understanding by Meadows (1980: 20).

The model also must be able to account for the dynamic tendencies of the system. These dynamic tendencies include such things as changing influences in the system due to plant growth and nonlinear feedback loops in the system. The model by Lindstrom and others (1991: 129-136), the best model that I found that simulated uptake and translocation, did not appear to account for these dynamic tendencies.

Keeping the requirements of the model in mind, the system dynamics approach to modeling appears to be the best choice for this research effort. The reasons for this

selection are as follows. First, the system dynamics approach to modeling is process-oriented (Meadows: 1980: 28). From the system dynamics paradigm, the rationale for building a model should be educational rather than predictive (Sterman, 1996: 227). Therefore, through the process of building a system dynamics model insights are gained about the system. Second, from the system dynamics view, the behavior of a system arises from the causal structure (Meadows, 1980: 31). The structure of the model is also believed to be much more important to model behavior than the estimated parameter values (Legasto and Maciariello, 1980: 41). Therefore, in model construction the focus is placed upon accurate description of the mechanisms and model structure rather than on parameter estimation. Third, since the system dynamics paradigm requires that every element and relationship have a readily identifiable real world counterpart it leads to a general understanding of the system (Meadows, 1980: 34). Finally, system dynamics models are built in a manner such that dynamic tendencies of a system, such as linear and nonlinear feedback loops, can be accounted for (Meadows, 1980: 33).

Model Development Process

There are four stages of model construction in the development of a system dynamics model (Randers, 1980: 285). These four stages are: conceptualization, formulation, testing, and implementation. These stages are briefly discussed below and in detail in the remaining sections of the chapter.

Conceptualization is the first stage in model construction. It entails determining what question is to be addressed, describing the reference mode, and describing the basic mechanisms of the system. The question to be addressed has already been defined in

Chapter One by the thesis purpose and research questions. The reference mode and basic mechanisms are discussed in the next section.

Model formulation is the process by which the conceptual model is transformed into mathematical relationships which can simulate the system of interest. Model testing is conducted to compare the behavior of the model to the reference mode (Randers, 1980: 121). It is also used to build confidence in the model and to give outside observers a yardstick by which they can measure the validity of the model. Model implementation entails two aspects (Randers, 1980: 121). The first is testing the model under different scenarios to gain insights about the system, and the second is translating these insights into information that is accessible and easily understood by others.

Finally, development of a system dynamics model is not plodding sequential process, but instead is an iterative one (Randers, 1980: 134-136). In the development of the model it will frequently be necessary to move back and forth between the different stages of model construction. For example, different sections of the model may be formulated separately. The first three stages for the first sector may be developed, then the second sector, and so on. These model sectors are subsequently integrated to make the comprehensive model. When testing the comprehensive model however, flaws may be discovered that force the modeler to move back to the formulation or conceptualization stage. Numerous iterations, such as those just described, were used in the development of this model.

Model Conceptualization and Formulation

Model conceptualization includes discussion of two areas: the reference mode and the basic mechanisms of the system. Model formulation is discussed in the closing section.

Reference Mode. The purpose of the reference mode is to provide focus to the modeler in model development (Randers, 1980: 121). It assists the modeler in making decisions concerning what to include or exclude from the model. Any mechanism not believed to be a major cause behind the generation of the reference mode should be left out of the model.

The reference mode can be developed in two ways (Randers, 1980: 122-127). The preferred method is to use historically observed or experimental data. A time series of data, showing the dynamic behavior of the system, provides solid basis for development of the model. The second option is to hypothesize as to what the reference mode should be. This method is used if the modeler is dealing with a system for which there is little or no historical data available.

There is experimental data available to establish a reference mode for this research effort. The research of Huang and Cunningham (1996: 75-84) and Kumar and others (1995: 1232-1238) is the basis for the reference mode of this model. As displayed in Figure 14 below, the expected behavior of a maize plant in taking up and translocating Pb leads to initially rapidly increasing concentrations of Pb in both the roots and shoots, but these concentrations eventually level off and reach a steady state. This assumes that the solution concentration is constant and not so high that it overwhelms the plant.

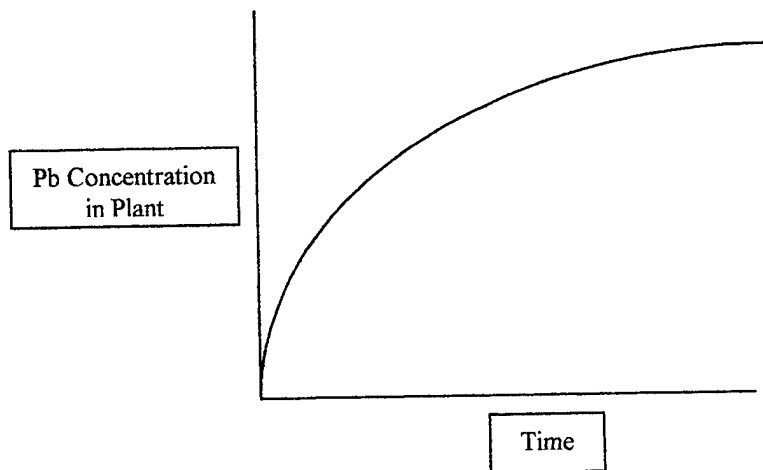

Figure 14 – Reference mode

One limitation of the studies from which this reference mode is drawn is that they only provide a picture over a limited period of time, about 20 percent of the growing season. No studies could be found that tracked time dependent behavior over an entire growing season

Basic Mechanisms. In this section the derivation and description of the fundamental mechanisms of a generic system is discussed in general terms. This process includes: identifying the key entities of the system; identifying the most important influences in the system; defining the system boundary; discussing the level of aggregation; and describing the basic mechanisms of the system in the form of an influence diagram.

An entity is defined as an object of interest from the system dynamics perspective (Shelley, 1997: class handout). An influence is defined as a force or factor that has a causal effect on an entity in the system. An example of an entity would be root Pb

concentration and an example of an influence would be plant growth

After determining the key entities and influences in the system, the next step is to define the system boundary. In selecting a model boundary, the modeler attempts to include all factors that are considered to significantly affect the problem being addressed (Legasto and Maciariello, 1980: 25). The setting of the model boundary includes the choice of its scope and aggregation level.

The structure of a system is the network of causal feedback loops necessary to explain why certain key elements within a system behave over time as they do (Roberts, 1983: 31). An influence diagram is used to describe these feedback loops. It includes those entities and influences of a system, and their feedback relationships, which are assumed to control system behavior. An example of an influence diagram is contained in Figure 15.

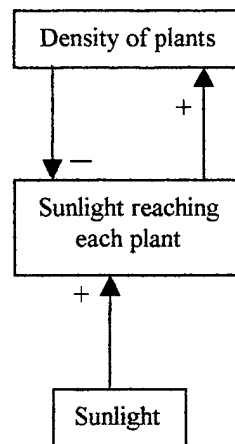

Figure 15 – Generic Influence Diagram

In Figure 11 density of plants is an entity, sunlight reaching each plant is an influence, and sunlight is an environmental parameter external to the system boundary. Causal relationships are depicted by an arrow. If the relationship is such that an increase (decrease) in the entity or influence causes the corresponding influence or entity to increase (decrease) then a plus (+) sign is drawn at the end of the arrowhead. The relationship is such that they tend to change in the same direction. This is a positive causal relationship. If an increase (decrease) in the entity or influence causes a decrease (increase) in the corresponding influence or entity, then there is a minus (-) sign drawn at the end of the arrowhead. The relationship is such that they tend to change in the opposite direction. This is a negative causal relationship. For example, since increasing the amount of sunlight that each plant receives tends to increase plant density, and decreasing the amount of sunlight that each plant receives tends to decrease plant density, this is a positive causal relationship.

Feedback from a system dynamics viewpoint is defined as the process where an initial cause ripples through a chain of causation ultimately to re-affect itself (Roberts, 1983: 16). Feedback in this very simple diagram is depicted by the causal loop between sunlight reaching each plant and density of plants. An increase (decrease) in sunlight reaching each plant tends to cause an increase (decrease) in density of plants. This is a positive causal relationship. On the other hand, the relationship between density of plants and sunlight reaching each plant is a negative causal relationship. These two relationships tend to cancel each other out. Therefore this is a negative feedback loop.

Model Formulation. This is the process of postulating the detailed structure of

the model (Randers, 1980: 119). It is a two-step process. The first step includes selecting levels and rates of influence and describing their determinants. This includes defining equations as appropriate. The second step involves the selection of parameter values as required to define influences, entities, and feedback relationships.

Model Testing and Validation

The concept of model testing and validation is fundamentally different with system dynamics models than with most other types of models. Testing in this document refers to comparison of the model to empirical reality for the purpose of corroborating or refuting the model (Forrester and Senge, 1980: 210). Validation is the process of establishing confidence in the soundness and usefulness of a model. A model may be valid for one purpose but not for another. The nature of system dynamics models permits many tests of model structure and behavior not possible with other types of models (Forrester and Senge, 1980: 209). Conversely, some widely used tests, such as standard statistical hypothesis tests, are either inappropriate or, at best, supplementary for system dynamics models. Rather than referring to model validity, confidence in a system dynamics model is often viewed as a more appropriate term.

Forrester and Senge (1980: 209-228) list 17 types of tests for building confidence in system dynamics models. Seven of these tests will be used on this model. These tests, which are described below are: structure-verification test, parameter-verification test, extreme-conditions test, boundary-adequacy test, behavior-reproduction test, behavior-anomaly test, and the behavior-sensitivity test.

The structure-verification test is a means of comparing the structure of a model

directly with the structure of the real system that the model represents (Forrester and Senge, 1980: 212). To pass the structure verification test the model must not contradict knowledge about the structure of the real system. The knowledge of the system may come from relevant literature or from the model builder's personal knowledge of the system. Review of the model structure by outside experts may also be appropriate.

The parameter-verification test is used to compare parameters in the model to the real system and see if they correspond conceptually and numerically (Forrester and Senge, 1980: 213). Conceptual correspondence means that model parameters match elements in the real system structure. Numerical correspondence means that the model parameters match the appropriate system parameters numerically.

In the extreme-conditions test, extreme values of parameters or variables are plugged into the model (Forrester and Senge, 1980: 213-214). Model output characteristics should remain plausible even under these extreme conditions. If model behavior is unreasonable under extreme conditions, it indicates probable flaws in model logic or structure. Additionally, this test may be used to analyze system behavior under conditions that are not normally experienced.

The boundary-adequacy test has two component tests (Forrester, 1980: 214-215 and 222). These two component tests check for the adequacy of the model boundaries in reference to structure and behavior. The boundary adequacy (structure) test considers structural relationships necessary to satisfy the purpose of a model. It focuses on whether the level of aggregation of the model is appropriate, and if the model includes all relevant structure. The boundary-adequacy (behavior) test considers whether or not a model

includes the structure necessary to address the issues for which it is designed. The test involves conceptualizing additional structure that might influence behavior of the model. The model is then tested with and without the additional structure to determine the effect on model behavior.

The behavior-reproduction test is used to examine how well model-generated behavior matches the observed behavior of the real system (Forrester and Senge, 1980: 217-218). For this model it will involve checking the behavior of model output characteristics and comparing them to the reference mode.

Model behavior is expected to match the behavior of the real system. However, model behavior may be anomalous. In this case the behavior-anomaly test is applied (Forrester and Senge, 1980: 220). Anomalies in model behavior may be traced to flaws in the model assumptions or model structure, or it may suggest real system behavior that has yet been unobserved. This test can also be used to show how unreasonable behavior may arise if model assumptions are changed.

The behavior-sensitivity test focuses on sensitivity of model behavior to changes in parameter values (Forrester and Senge, 1980: 222-223). Plausible changes in model parameters should not cause the model to behave unreasonably or to fail any of the tests that were previously discussed.

Model Application

After formulating the model and testing it to ensure that it is valid for its intended purpose it may be used to gain insights about possible phytoextraction management situations. The scenarios that will be explored in this research include looking at what

time frames appear to be optimum for harvesting maize and suggested time frames for applying chelates to soil and subsequently harvesting the plants.

In summary, the methods set forth in this chapter provide a systematic process for building, testing, and applying a system dynamics model that simulates maize uptake and translocation of Pb. The modeling approach selected will force me to closely examine all the elements of the system, and should lead to insights concerning system mechanisms as the system entities and influences are identified and tied together. As the model is tested, flaws in the model will be revealed. Subsequent model revisions should provide an even more accurate depiction of the system, and result in more insights concerning its fundamental mechanisms. Building, testing, and revising will continue until I feel confident that this model is a reasonable simulation of the real simulation. Once this is achieved, the model may be applied to gain more practical information about the phytoextraction process that may be useful to managers.

4. Results and Analysis

As a result of model development and testing, insights have been gained regarding the basic mechanisms of this system. The results are presented and analyzed in this chapter. It is organized into the following sections: model conceptualization – basic mechanisms, model formulation and presentation, model testing and validation, and phytoextraction management scenarios. In the model conceptualization section the basic mechanisms that are assumed to control a maize plant with respect to uptake and translocation of Pb will be presented. This section includes the identification of key system entities and influences, designation of a boundary for model development, discussion of the level of aggregation, and presentation and explanation of the influence diagram. The model formulation and presentation section describes how the basic mechanisms of the system were formulated into the model structure and parameters. The testing and validation section includes the results of the seven tests that were selected to validate this model. The final section of this chapter explores some model capabilities for assisting researchers and managers in making decisions concerning phytoextraction management practices.

Before moving to the first section, a brief explanation of why most of the specific aspects of model conceptualization and formulation for this system are included in this chapter is appropriate. The purpose of this research is to gain insights into plant mechanisms concerning uptake and translocation of Pb. The modeling approach that was selected leads the modeler to insights regarding basic system mechanisms in the process of developing the model. In other words, some of the most important insights into this

system will be gained during conceptualization and formulation of the model. Therefore, it was considered appropriate to include these sections in the results chapter.

Model Conceptualization – Basic Mechanisms

This section includes discussion of the key entities and influences, system boundary, level of aggregation, and the influence diagram. The discussion in this section will focus on high-level mechanisms. The mechanisms that are included here are broken down in more detail in the model formulation section.

There are assumed to be five key entities in this system:

1. Pb in soil solution. This is outside the system boundary and is assumed to be a constant environmental parameter in this model.
2. Pb in the root.
3. Pb in the stem.
4. Pb in the leaves.
5. Pb in the ear.

The Pb in the root, stem, leaf, and ear includes both soluble and precipitated Pb.

These key entities in the system are affected by other factors. These factors are identified as the key influences in the system. The assumed key influences include:

1. Pb uptake from soil solution.
2. Translocation of Pb in the xylem.
3. Translocation of Pb in the phloem.
4. Precipitation of Pb throughout the plant.
5. Plant growth.

6. Plant transpiration.

The focus of this research effort is on the internal mechanisms of uptake and translocation of Pb in a plant. With this in mind, the system boundary is defined as the exterior surface of the plant. There are assumed to be no inputs from, or outputs to, the atmosphere from the shoots. The root is the source of entry for all inputs of Pb to the plant. Finally, the soil solution is considered to be outside the system boundary and is therefore considered to be a constant environmental parameter.

The level of aggregation in this model will be low. In other words there will be a significant amount of detail in the model. A deliberate decision was made to initially construct this model with a high level of detail. This decision was made based upon my lack of knowledge and intuition of the system. It was hoped that this level of detail would help me develop more intuition about the system, thus facilitating my search for insights concerning the mechanisms of the system. The level of model detail could then be reduced as my intuition developed and insights were gained concerning the system. This is a departure from a pure systems dynamic approach and is discussed in more detail in Chapter 5.

The basic mechanisms of a maize plant in taking up and translocating Pb are diagrammed in Figure 16. This diagram includes only the high-level assumed entities, influences, and causal relationships. Basic mechanisms described in this diagram are expanded upon in the model as discussed in the next section. Causal relationships are depicted as previously described. Those affecting the phloem are depicted by a dashed arrow, and those affecting the xylem/tissue by a solid arrow.

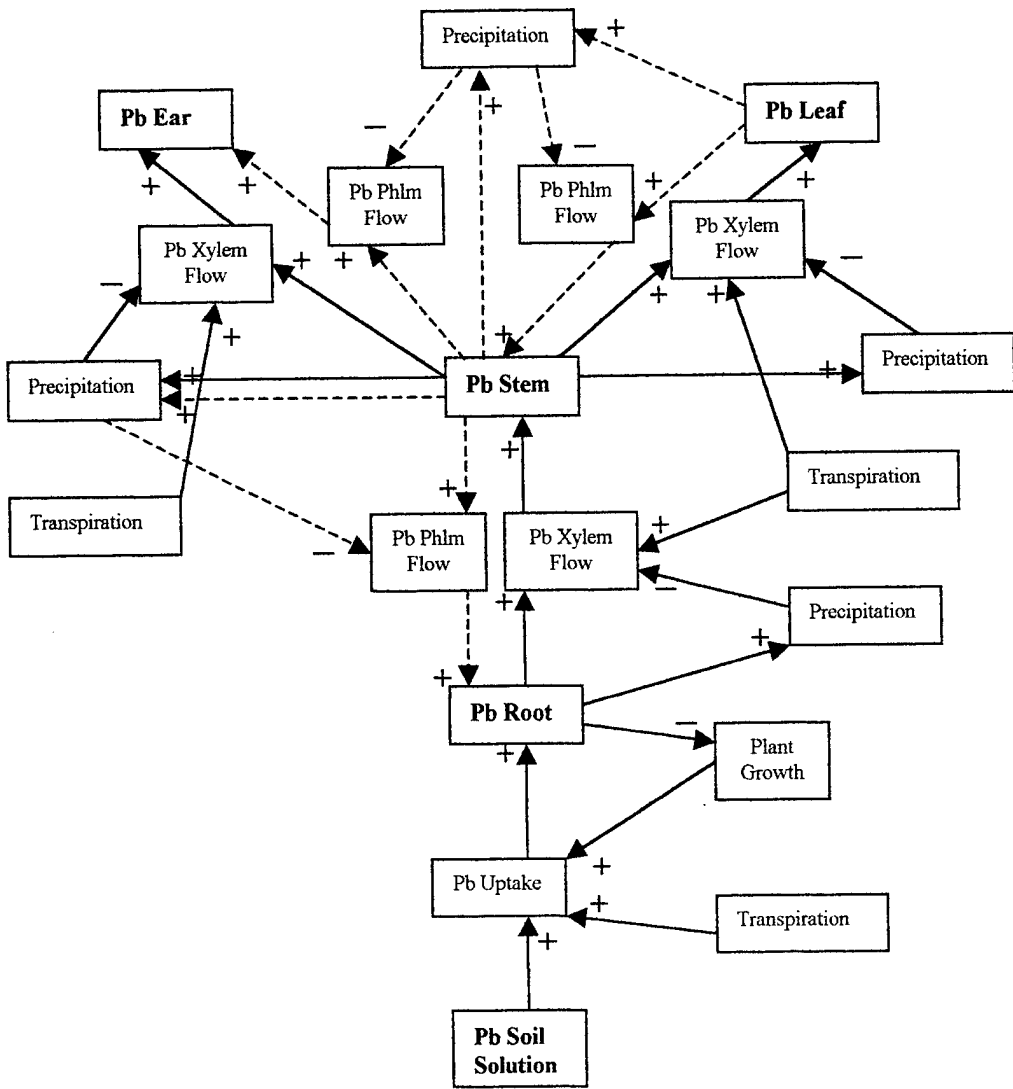

Figure 16 – Influence diagram

Model Formulation and Presentation

This section contains a description of how this model was formulated from the basic mechanisms, and includes the key assumptions that were made in the process. The model is comprised of the following sectors: plant growth and physical parameters, Pb mass and concentrations, transpiration, root, stem, leaf, and ear. Following a general description of how the basic mechanisms identified during model conceptualization were

further refined during model formulation, each of the model sectors will be described in general terms. The precise details of the model structure, including flow diagrams, all equations, and parameter values, are included in Appendices A and B. As the model is presented, assumptions that have been made will be mentioned. A complete list of assumptions and the source from which they were drawn is contained in Appendix F. The reader is also referred to the literature review for further discussion of these. Before discussing how the model was formulated, some of the features of the model software that are used for this simulation will be highlighted.

Model Software. The model software that was selected for this simulation is Stella II, which was developed by High Performance Systems (Peterson and Richmond, 1994). Models are constructed in Stella II by defining relationships through flow diagrams and equations that correspond to the relationships between flow diagram objects. The system of equations that defines the model is then solved using numerical integration methods. The numerical integration method that was selected for this simulation algorithm is the Euler method.

Refinement of Basic Mechanisms. Basic mechanisms that were identified during model conceptualization were further refined during the process of formulating the model. A general description of these refinements is included below. Details of refinements are contained in the next section.

Lead in Soil Solution/Pb Uptake. The Pb concentration in solution that is relevant for uptake is not the concentration in soil solution, but the Pb solution concentration at the surface of the root and in the root cortex apoplast (RCA). This is

affected by transpiration, diffusion, and precipitation at the root surface. Uptake of Pb means that Pb is physically taken into the symplast of the root.

Translocation of Pb in the Xylem. This includes the distribution of Pb in the root once it is taken into the symplast, and the processes of moving it to and through the xylem. The influences on translocation to the shoots include not only precipitation and transpiration, but also adsorption of Pb onto the xylem cell walls, transfer of Pb from the xylem to the phloem, and diffusion from the tissue back into the xylem.

Translocation of Pb in the Phloem. The movement of Pb in the phloem is affected by flow of Pb from the tissue in the leaves back into the phloem. The flow also depends upon whether the ear or root is the primary sink for phloem flow, which is in turn affected by plant growth. The flow is also affected by precipitation in the leaves and the phloem, by transfer of Pb from the xylem to the phloem, and by the xylem flow rates.

Precipitation of Pb throughout the Plant. Precipitation is assumed to occur not only in the tissue of all the compartments, but also in the xylem, phloem and at the root surface/RCA.

Plant Growth. This influences the amount of root mass available for uptake of Pb. It also affects the volume and mass of plant compartments which in turn affects the concentration of Pb in these compartments.

Plant Transpiration. This influences the concentration of Pb at the surface of the root, as well as the flow of xylem and phloem sap.

Plant Growth and Physical Parameters. This sector simulates the growth of the plant, as well as the development of the root, stem, ear, and leaves, and the corresponding

development of xylem, phloem, and tissue. Increase in shoots dry mass was assumed to increase in a sigmoidal pattern during the growing season. Live mass of the root, stem ear and leaf were then derived using: shoots and root water fractions; shoots to root ratios; dry mass fractions (percent of total shoots dry mass) of the stem, ear, and leaf varying over the growing season; growth retardation from Pb concentrations in the root.

Key assumptions in the sector are as follows:

1. The growing season of a maize plant is 125 days, starting with emergence of the seedling from the soil.
2. Shoots and root water fractions are mass fractions. They both decrease slightly over the growing season.
3. Growth will be retarded in the plant with increasing concentration of Pb in the root, and will completely cease if concentrations are too high.
4. Root growth can be defined by a shoot to root ratio with respect to the shoots live mass. This ratio increases during the growing season.
5. Dry mass fractions as defined in the literature for the stem, ear, and leaves are also valid for plant live mass.
6. One gram of live plant mass has a volume of one milliliter.
7. The shoots dry mass is 0.374 kg at maturity. Refer to Appendix C for calculations drawn from literature values.

These assumptions were all drawn from literature values, with the exception of volume fractions of the xylem, phloem, and tissue which were estimated from plant cross-section slides and drawings in the literature.

Lead Mass and Concentrations. This model sector includes computations of total Pb and precipitated Pb mass in the root, stem, leaf, and ear. From these mass calculations, and using plant dry mass calculations from the plant growth sector, plant concentrations of Pb are calculated. These concentrations are figured for the root, stem, ear, leaf, and total shoots on a mass (mg) per mass (kg) basis.

Transpiration. Transpiration is the dominant factor in determining xylem flow rates, and since phloem flow rates are proportional to xylem flow rates, they are also affected. Transpiration also influences the amount of Pb in soil solution that is delivered to the root surface by mass flow. Since no literature values could be found showing how maize daily transpiration rates vary during a growing season, this factor had to be calculated. This could be achieved by using literature values for maize transpiration coefficients for maize and shoot dry mass production. As covered in Chapter Two, this coefficient is the total liters of water a maize plant transpires during a growing season per kg of dry mass. Multiplying the transpiration coefficient by the shoot dry mass at the end of the growing season the total amount of water transpired by a plant can be computed. Using the transpiration coefficient (TC), and the plant growth computations, a method was derived for determining daily transpiration rates for maize.

Total seasonal transpiration for each day (TSTD) is actually the amount of water that is required to produce the new plant mass on that day, as well as the amount to maintain it for the rest of the season. It is not the actual daily transpiration rate. Daily transpiration is assumed in this model to be comprised of two components. Transpiration that occurs on a given day to produce new plant mass (T(NMP)), and transpiration that

occurs to maintain existing plant mass (T(maintenance)). Daily transpiration can therefore be described by the following equation:

$$\text{Daily Transpiration} = T(\text{NMP}) + T(\text{maintenance})$$

$$T(\text{NMP}) = \text{transpiration required to produce new plant mass on day D}$$

$$T(\text{maintenance}) = \text{transpiration required to maintain existing plant mass}$$

It is also assumed that as the season progresses, the fraction of the TSTD attributed to T(NMP), the NMP fraction, increases until it equals one on the last day of the growing season. The fraction attributed to T(maintenance), the maintenance fraction, equals one minus the NMP fraction, and therefore decreases until it reaches zero on the last day of the growing season. T(maintenance) for each day is then divided by the number of days left in the growing season and added to the running total. For example:

$$\text{Daily Transpiration (on Day 3)} = T(\text{NMP}) + T(\text{maintenance})$$

$$T(\text{NMP}) = \text{TC} * \text{new dry mass on day 3} * \text{NMP fraction}$$

$$T(\text{maintenance}) = (\text{TC} * \text{new dry mass on day 1} * \text{maintenance fraction on day 1} / 124) + (\text{TC} * \text{new dry mass on day 2} * \text{maintenance fraction on day 2} / 123)$$

Using this method in a model simulation run, and with a Pb concentration in soil solution of zero (so there would be no growth retardation), the sum of daily transpiration during the growing season was computed as 126.8 liters. This was less than three percent different than the product of the empirical formula (transpiration*final shoots dry mass) = 130.5 liters. The shape of the curve generated, as shown in Figure 17 below, also appears to be in reasonable agreement with the leaf area index of maize during the course of the growing season (Ritchie, 1973: 894). This leaf area index appears to be the best

available measure to compare with the seasonal variations in transpiration.

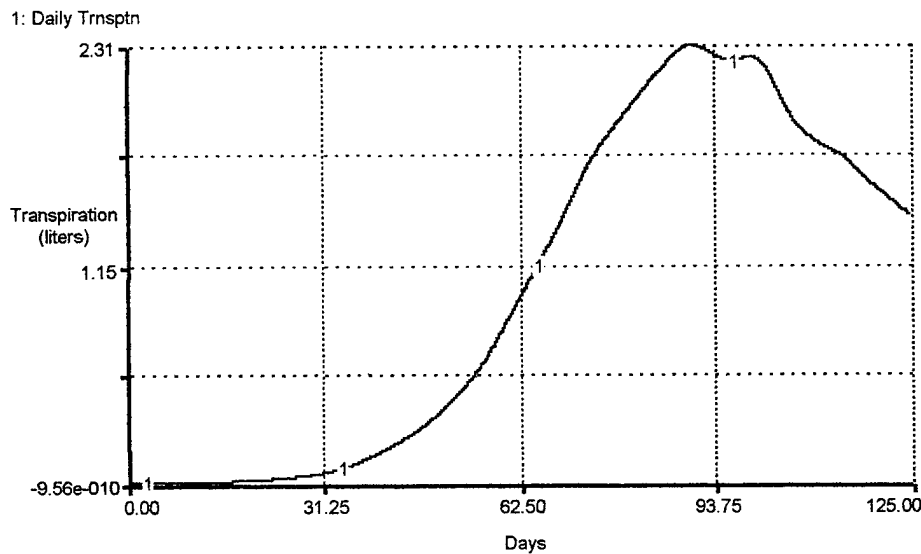

Figure 17 – Daily Transpiration

The method just described is used in this model to determine time dependent transpiration by maize. Since this links transpiration with plant growth, if plant growth is retarded transpiration will also be retarded.

Root. Explanation of the model root sector is broken down as follows:

1. Root surface and root cortex apoplast (RCA).
2. Uptake into the root symplast.
3. Precipitation in the tissue (root symplast and apoplast inside the stele are the tissue).
4. Movement from the root tissue to the xylem.
5. Movement in the xylem. This includes adsorption, precipitation, transfer to the phloem, and translocation to the stem.
6. Movement in the phloem.

Root Surface and Root Cortex Apoplast (RCA). The Pb in soil solution is an environmental parameter in this model. It is assumed that the only species of Pb in solution that is relevant in determining the uptake of Pb is Pb^{2+} . This follows from the discussion in the literature review and from the calculations in Appendix D.

The Pb in soil solution moves to the root surface and RCA by the process of mass flow and diffusion. At the root surface and in the RCA the Pb will be preferentially bound due to the CEC of the root. In the model, mass flow is assumed to be equal to the product of transpiration and soil solution concentration. The diffusion and preferential binding are described by a partition coefficient and partitioning rate.

At the root surface and in the RCA it is assumed that Pb will precipitate. The precipitation reaction is assumed to be controlled by equilibrium Pb solubility, the concentration of Pb in solution, and the rate at which the chemical reaction reaches equilibrium. It is assumed that the dominant form of precipitate will be a Pb-phosphate, therefore equilibrium solubility of Pb is controlled by total soluble phosphate and pH. Soluble phosphate levels are assumed to be higher here than in the plant tissue while pH levels are lower. Calculations for total Pb solubility are contained in Appendix D. The concentration equals the soluble Pb in the RCA plus that at the root surface divided by the volume. It is assumed that the precipitation reaction will initially occur rapidly, reaching equilibrium several times per day. However, it is also assumed that this precipitation rate will rapidly decrease as Pb-precipitate builds up on the root surface and RCA. This is because research has shown that after an initial rapid buildup of Pb-precipitate at the root surface, very little Pb precipitates (Malone and others, 1974: 388).

Uptake into Root Symplast. The Pb that remains soluble at the root surface and in the RCA is then available for uptake into the root symplast. It is assumed that uptake into the root symplast will occur in accordance with Michaelis-Menten kinetics as described in Chapter Two and the equation:

$$U = (V_{\max} * K_m) / (K_m + C)$$

U = uptake rate (milligrams of Pb per (kg of root dry mass*day))

V_{max} = maximum uptake rate (milligrams of Pb per (kg of root dry mass*day))

K_m = solution concentration where uptake is half-maximal (mg of Pb per liter)

C = concentration of Pb in solution (mg of Pb per liter). In this case it is the concentration in the RCA/root surface.

Values for K_m and V_{max} were calculated from the experimental data of Huang and Cunningham (1996: 78). Calculations for these parameters are contained in Appendix E. The derived values (V_{max} = 184 and K_m = 8.3) are similar to those that Peake (1996: 89) arrived at (V_{max} = 219 and K_m = 9.4) using wild rice (*Zizania aquatica*). The uptake rate is then multiplied by the dry root mass to get the uptake into the root symplast in milligrams of Pb per day.

Precipitation in the Tissue. Once Pb is taken into the symplast, it is assumed that some of the Pb will precipitate. The processes that occur in root cells to cause precipitation of Pb to occur are assumed, in aggregate, to be comparable to precipitation processes in an aqueous solution. Therefore, the precipitation reaction is controlled by equilibrium Pb solubility, concentration of Pb in solution, and the rate at which the chemical reaction reaches equilibrium. It is assumed that the dominant form

of precipitate will be a Pb-phosphate, and thus Pb solubility is controlled by total soluble phosphate as well as cellular pH levels. The total soluble phosphate in the cell is assumed to be a constant small fraction of the total plant concentration of phosphate since most of the phosphate will be bound within the cell. The tissue pH is assumed to be 7.0. Calculations for total Pb solubility are contained in Appendix D. The solution concentration is the Pb that remains soluble (mg) per liter of plant volume. It is assumed that the precipitation reaction will occur rapidly, reaching equilibrium several times per day. Finally, precipitation reactions throughout the plant are assumed to occur in a manner analogous to the one just described.

Root Tissue to Xylem. Movement from the root tissue to the xylem is assumed to occur through cytoplasmic streaming in the symplast as described in Chapter Two. As previously discussed, how Pb is finally loaded into the xylem has not been firmly established, but it is clear that it must cross a plasmalemma at some point before this occurs. The key assumption here is that the process can be described by mass flow. This mass flow is the product of soluble Pb concentration in the root tissue and the flow of sap into the xylem. The flow of sap into the xylem is assumed to be equal to the flow of sap that passes through the xylem from the root to the shoots.

Movement in the Xylem. Movement of Pb in the xylem from the roots to the stem is assumed to occur by mass flow. This mass flow is the product of the concentration of Pb in solution and the flow of sap through the xylem from the roots to the stem. The xylem flow rate out of the root to the stem is assumed to be equal to the daily transpiration rate.

Precipitation in the xylem is assumed to occur as previously described with two exceptions. The pH of the xylem is assumed to be 5.5, and the precipitation reaction is assumed to reach equilibrium fewer times each day due to the rapid movement of Pb in the xylem.

Retardation of flow in the xylem is assumed to occur because of adsorption onto the xylem cell walls. The level of retardation depends upon how many Pb^{2+} ions are sorbing and how many are desorbing. It is assumed that as the concentration of Pb in the xylem cell wall (mg of Pb per kg dry mass) increases, the amount of ions sorbing decreases relative to the amount desorbing. As concentration continues to increase breakthrough occurs, at which point ions are desorbing as fast as they are sorbing. Therefore, retardation due to adsorption is initially high, but rapidly decreases until there is no retardation once breakthrough occurs. Finally, some of the Pb that is transported in the xylem is assumed to be transported as neutral complexes, and thus retardation due to adsorption is always less than 100 percent.

A small fraction of the Pb in the xylem is assumed to be actively transported to the phloem as discussed in Chapter Two. This is also described as a mass flow process, and is the product of the xylem flow rate, a small fraction (describing the portion of xylem flow going to the phloem), and the concentration of Pb in the xylem.

Phloem Flow. The root is assumed to be a sink for photosynthates that are produced in the leaves. Early in the season all of the phloem flow from the leaves goes to the root. As the ear begins to develop, it becomes the dominant sink for photosynthates and very little phloem flow goes to the root. The Pb that is transferred to

the root through the phloem is assumed to move by mass flow along with the photosynthates and phloem sap. It is therefore the product of the concentration of Pb in the phloem and the phloem sap flow rate. Phloem sap flow rates are assumed to be proportional to xylem flow rates, but always less. Phloem flow rates are also assumed to vary in proportion to xylem flow rates, reaching their maximum relative value (20 percent of xylem flow rate) when the leaves mature and begin to senesce.

Precipitation of Pb is also assumed to occur as previously described with two differences. The pH of the phloem is assumed to be 8.0, and the precipitation reaction is assumed to reach equilibrium fewer times each day than in the tissue, but more times each day than in the xylem. This is because movement in the phloem is assumed to be more rapid than in the tissue, but slower than in the xylem. There is assumed to be no retardation due to adsorption in the phloem.

Stem. This sector includes those processes that control Pb storage and translocation in the stem. Discussion in this section will cover:

1. Movement of Pb in the xylem.
2. Movement of Pb in the tissue.
3. Movement of Pb in the phloem.

Movement in the Xylem. Lead that is translocated to the stem from the root comes through the xylem. Subsequently it is transported to the ear or leaf compartment, or it moves into the stem tissue. Xylem flow to each of these compartments is assumed to be a mass flow process as it was in the root. It is also assumed that xylem flow must be conserved -- xylem flow in from the root will equal the

sum of xylem flows to these three compartments. The fraction of the total flow going to each compartment is assumed to be proportional to the amount of transpiration that occurs there. Therefore flow to the leaves will always be the highest, flow to the ear always the lowest, and flow to the stem intermediate. Flow into the ear is not assumed to occur until day 40 when the ear begins to develop. Active transport of Pb from xylem to phloem will also occur in the stem as it did in the root, though the transfer fraction will be slightly higher. Finally, retardation due to adsorption and precipitation in the xylem are assumed to occur in the stem in the same manner as that in the root.

Movement in the Tissue. After moving into the stem tissue by mass flow, Pb is assumed to precipitate in the same manner as in the root tissue. Diffusion of Pb from the stem tissue back to the xylem is assumed to also occur. The rate of diffusion is assumed to be proportional to the concentration gradient between the stem tissue Pb solution concentration and the solution concentration in the xylem, and is scaled by a transfer rate coefficient. The magnitude of this coefficient is highly uncertain. However, as is shown in the model validation and testing section, the model is not sensitive to variations in this parameter, even when it is varied by several orders of magnitude.

Movement in the Phloem. The stem is assumed to act as a conduit for phloem flow of Pb from the leaves to the root or ear. It is assumed that the stem is neither a source nor a sink for phloem flow (Marschner, 1983:20-24, Salisbury and Ross, 1992: 164 and 181, Kochian, 1991: 249, and Marschner, 1986: 87). Therefore the net flow of Pb into or out of stem tissue from the phloem is zero. In the stem the phloem flow from the leaves is assumed to be apportioned to either the ear or the roots. Before

day 40, all phloem flow goes to the roots. As the ear begins to develop, a portion of the phloem flow goes to the ear. It is assumed that the fraction of the phloem flow to the ear will increase as the ear mass fraction increases, and will quickly reach its maximum value of 0.9. The phloem flow fraction to the root will likewise decrease until it reaches a minimum value of 0.1. The movement of Pb to the root and ear is again assumed to be by mass flow. Precipitation is assumed to occur as described previously.

Leaf. This sector includes those processes that control Pb storage and translocation in the leaf. Discussion in this section covers:

1. Movement of Pb in the xylem.
2. Movement of Pb in the tissue.
3. Movement of Pb in the phloem.

Movement of Pb in the Xylem. Lead is assumed to flow into the leaf xylem compartment from the stem xylem. All of the Pb in the leaf xylem is then assumed to move by mass flow into the leaf tissue except for that which is precipitated as described previously.

Movement of Pb in the Leaf Tissue. Lead in the tissue is assumed to precipitate as it does in the root or stem tissue. Diffusion of Pb back into the xylem from the leaf tissue was found to have no impact upon system behavior through sensitivity testing and thus was not included in the final model structure. This is discussed in greater detail in the Boundary Adequacy Test section. There is assumed to be movement out of the stem tissue into the phloem. This again is assumed to be a mass flow process, with the Pb that remains in solution in the tissue moving along with photosynthates into

the phloem. Since all of the phloem flow from the leaf goes to the stem, the rate of flow out of the leaf is assumed to be the same as the flow in the phloem to the stem.

Movement in the Phloem. Movement of Pb in the phloem from the leaf to the stem is assumed to be by mass flow. The rate of phloem movement is assumed to be proportional to, but less than, the xylem flow rate. As the live mass of the leaf compartment increases it is assumed that the phloem flow rate will increase relative to the xylem flow rate until it reaches a maximum fraction. Precipitation in the phloem is assumed to occur as previously discussed.

Ear. This sector includes processes that control Pb storage and translocation in the ear, with these processes not beginning until day 40 when the ear begins to develop.

Discussion in this section will cover:

1. Movement of Pb in the xylem.
2. Movement of Pb in the tissue.
3. Movement of Pb in the phloem.

Movement of Pb in the Xylem. Movement of Pb and precipitation in the ear xylem is assumed to occur in the same manner as the leaf compartment. The only difference being that the flow will be much lower since far less transpiration occurs in the ear than the leaf.

Movement of Pb in the Ear Tissue. Movement of Pb into the leaf tissue from the xylem and precipitation are assumed to occur in the same manner as in the leaf. In contrast to the leaf, Pb flows into the tissue from the phloem by mass flow. Since phloem flow enters the ear and does not exit, the rate of flow into the tissue from the

phloem is assumed to be the same as the flow in the phloem.

Movement in the Phloem. The phloem flow rate is assumed to be a fraction of the phloem flow rate out of the leaf. This fraction quickly increases as the mass fraction of the ear increases and reaches a maximum of 0.9. The concentration of Pb in the phloem is affected by precipitation as discussed previously.

Model Testing and Validation

The results of the seven model validation tests in this section will be analyzed in the following order: structure-verification test, behavior-reproduction test, boundary-adequacy test, parameter-verification test, behavior-sensitivity test, extreme-conditions test, and behavior-anomaly test. All model runs made in this chapter are made with the baseline model parameters and structure as noted in Appendix B unless otherwise stated.

Structure-Verification Test. This test involves comparing the structure of the model with the structure of the real system (maize as it uptakes and translocates Pb). To pass the test the model must not contradict knowledge about the structure of the real system. This model was built upon information in the literature to the extent that it was available. In areas where there was little or no information available means of characterizing the relevant process were selected that seemed to be the most logical. Table 2 summarizes the relative uncertainty of the characterization of mechanisms within the model. The level of uncertainty was rated as low if there was substantial information in the literature about the mechanism, medium if there was some information, and high if there was little or no information. Scrutiny by outside experts of the characterization of these mechanisms, especially those rated as high, would be appropriate.

<u>Model Mechanism</u>	<u>Relative Uncertainty of Characterization</u>
Precipitation at Root Surface and within Plant	High
Mass Flow in Phloem and Xylem	Low
Mass Flow into Tissue and from Root Tissue into Xylem	Medium
Considering only Uptake of Pb ²⁺ from Soil Solution	Low
Transpiration	Medium
Uptake	Low
Diffusion and Preferential Binding at Root Surface	Medium
Plant Growth	Low
Plant Growth Retardation	Low
Adsorption	High

Table 2 – Relative Uncertainty of Model Mechanism Characterization

Behavior-Reproduction Test. This test is used to examine how well model-generated behavior matches the observed behavior of the system by comparing model output characteristics to the reference mode. As can be seen from Figure 18 below, the baseline model output did not match the reference mode. Instead of reaching a steady state value, the concentration of Pb in the both the roots and shoots of the simulated maize plant continued to increase throughout the growing season. As my knowledge and intuition concerning this system increased during the model formulation process, it became apparent to me that the behavior of the model might not match the reference mode. This is because the model contained no efflux of Pb from the system, and uptake of Pb was dependent upon only one time dependent factor – root mass. The baseline model output confirmed my intuitions. Therefore, it would be necessary to hypothesize additional mechanisms that included influences now better understood through the model formulation process.

The first mechanism that was considered was efflux of Pb from the plant. After communications with Bleckmann (1997: personal communication), Huang (1997:

personal communication), and Salt (1997: personal communication), it became clear that Pb efflux was most likely negligible. Therefore this mechanism was not included in the model.

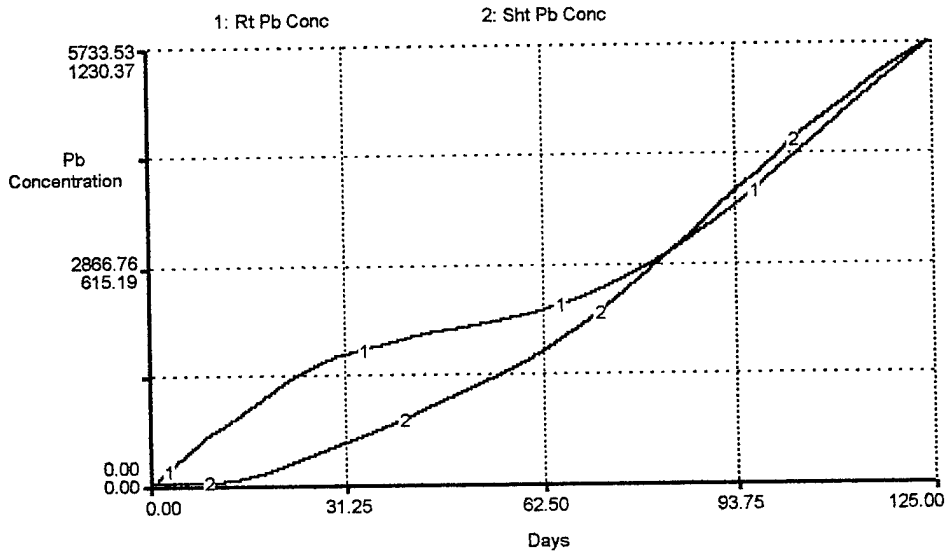

Figure 18 – Baseline model output

The second hypothesized mechanism was that of decreasing effective root mass throughout the course of the growing season. In other words, as the maize plant grows older it uses less of its root mass to uptake water and nutrients, including Pb, from the soil. Various literature sources state that a plant uses only a fraction of its total root capacity to uptake water and nutrients (Mengel and Kirkby, 1987: 95 and Robinson, 1991: 112- 115). Also, as a plant ages the amount per unit length of root that it must uptake to sustain the shoots, and its capacity to uptake water and nutrients, decreases. Using this information, an effective root mass factor was included in the model structure. This factor, which is a fraction, decreases throughout the growing season and is

multiplied by the root mass in determining Pb uptake.

Figure 19 shows how the behavior of the system changes with the effective root mass mechanism. Both root and shoot Pb concentrations level off and appear to reach a steady state at about day 100, with root Pb concentration beginning to level off much earlier than shoot Pb concentration. This behavior matches the reference mode with the exception that the system came to a steady state slower than was expected. Steady state occurred in the experimental study (Huang and Cunningham, 1996: 79) at about day 20 compared to about day 100 with the model.

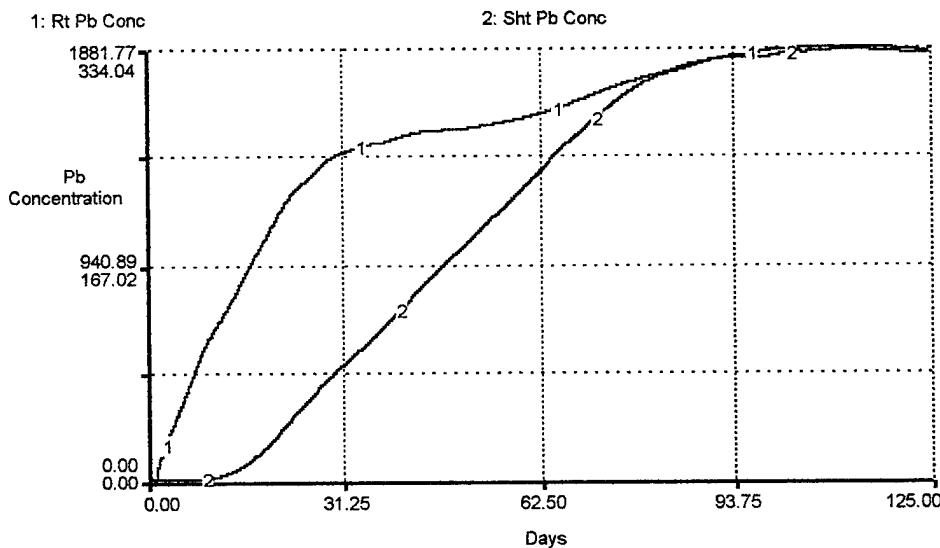

Figure 19 – Baseline model output with effective root mass mechanism

The second hypothesized mechanism related to the maximum rate of uptake of Pb, the V_{max} value. The work of Huang and Cunningham (1996: 79) suggests that uptake of Pb inhibits total cation accumulation in both maize and ragweed and that this may occur due to Pb blockage of cation uptake channels (1996: 82). This blockage could be reflected by a decrease in the V_{max} values as Pb uptake increases. Marschner (1986:

23 and 49-50) also suggests that maximal uptake rates for essential nutrients such as K can vary considerably and that V_{max} values may change for any plant depending upon age and nutritional status. Taken in concert, these statements lend credence to a postulated mechanism where the V_{max} value for Pb decreases with increased uptake of Pb. Further, the decrease in V_{max} should be related to the stunting of plant growth that occurs with increased concentrations of Pb in the roots. This hypothesized mechanism has been incorporated into the model structure and the effects on model output characteristics are shown in Figure 20.

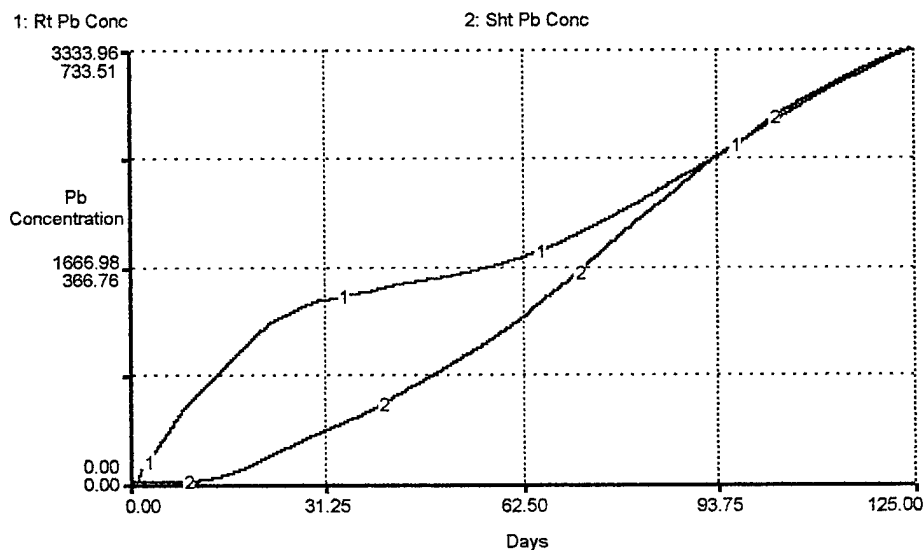

Figure 20 – Baseline model output with decreasing V_{max} mechanism

With this mechanism added to the baseline model structure the output behavior changes only modestly. The system does not reach steady state by the end of the growing season, but this mechanism appears to dampen the increases in Pb concentration.

However, as can be seen from Figure 21, when the effective root mass and decreasing V_{max} mechanisms are combined, system behavior appears to match the reference mode

better than with either mechanism by itself. Comparing system behavior in the roots (Figure 22) and the shoots (Figure 23) without either mechanism (trace 1), with the effective root mass mechanism added (trace 2), and with both effective root mass and decreasing Vmax mechanisms added (trace 3) shows this more clearly. The system appears to reach steady state in a time frame that more closely matches the time frame of the experimental study. The steady state values for Pb concentration in the roots (2000 mg of Pb/kg dry mass) and shoots (375 mg of Pb/kg dry mass) in the reference mode study are also reasonably close to those of the model simulation (1550 and 255). With the addition of the hypothesized mechanisms the model appears to pass this test. These mechanisms will be included in the model structure for the remaining tests.

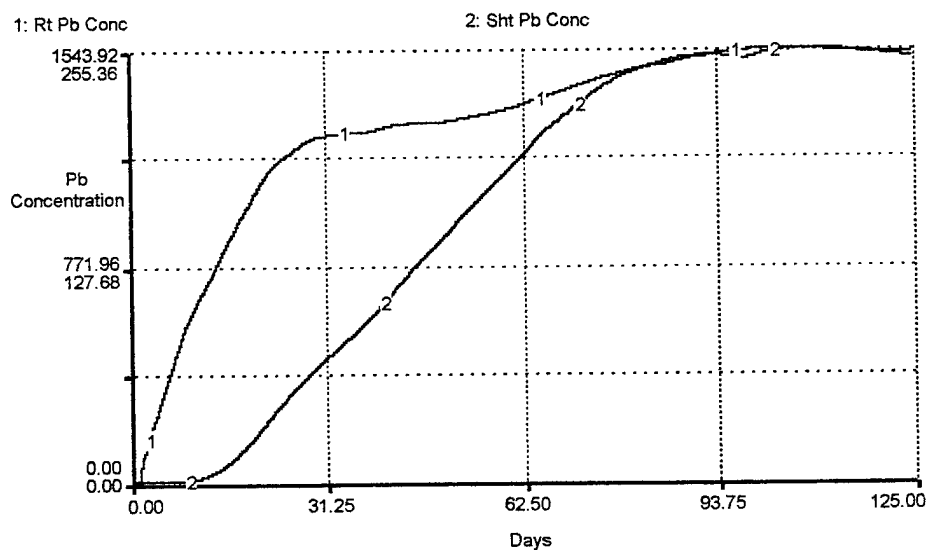

Figure 21 – Baseline output with effective root mass and Vmax mechanisms added

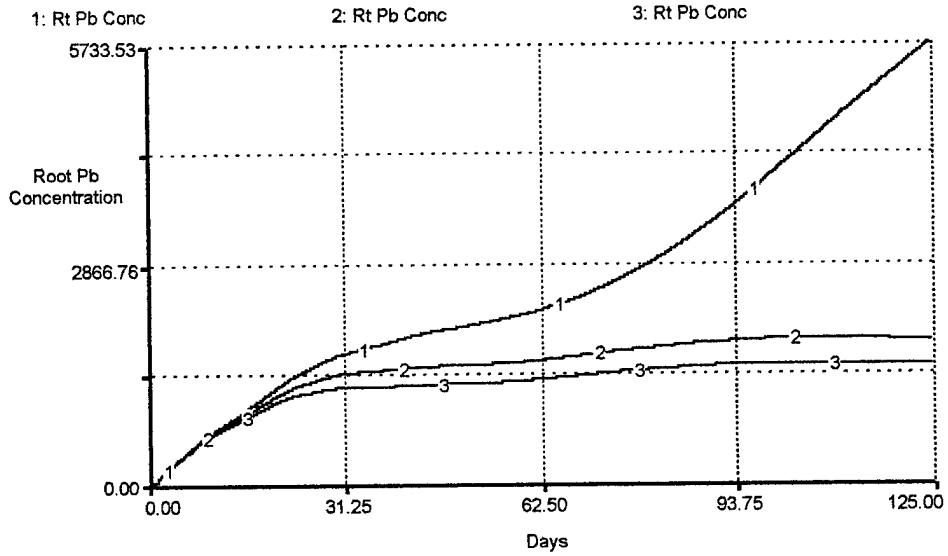

Figure 22 – Baseline output in root with and without hypothesized mechanisms

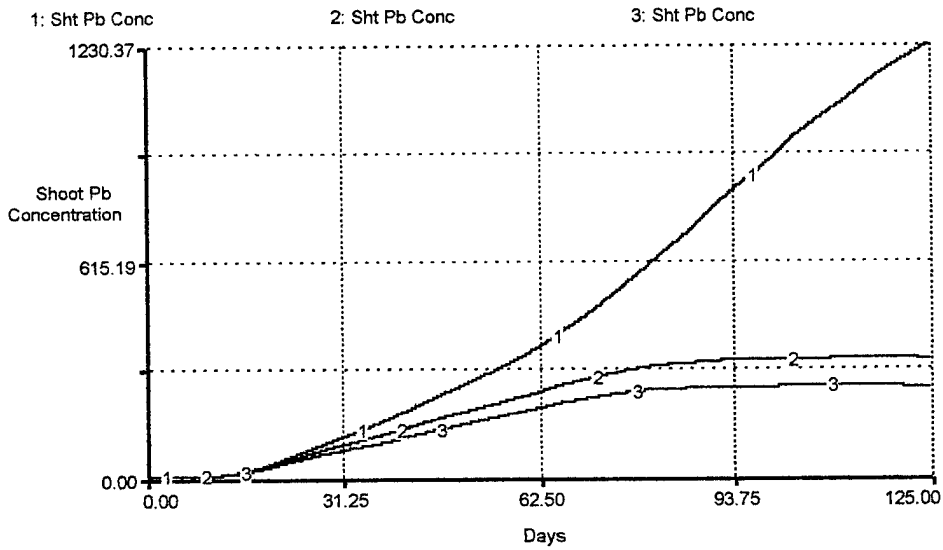

Figure 23 – Baseline output in shoots with and without hypothesized mechanisms

Boundary-Adequacy Test. This test is used to check the adequacy of the model boundaries in reference to structure and behavior – to determine whether the level of aggregation is appropriate to satisfy the purpose of a model.

Since this model was approached with the notion that a high level of detail was at least initially preferable, it would seem unlikely that relevant model structure has been left out. On the other hand, as the model structure was examined, it appeared that there was excessive detail in the model structure. Boundary-adequacy (behavior) testing of the model confirmed this notion.

Model behavior was tested with two mechanisms in the model turned off and on. After it was found that that these mechanisms had no impact on the behavior of the system, they were removed. The first of these was a diffusion mechanism in both the ear and leaf. As can be seen in Figures 32 and 33 in Appendix G, inclusion or exclusion of these mechanisms had no impact on model behavior even when the transfer rate coefficient was varied by four orders of magnitude. Similar results were found when the xylem adsorption mechanism was included and excluded from the ear and leaf. These results are shown in Figures 34 and 35. The results of the boundary-adequacy test would appear to add to the validity of this model.

Parameter-Verification Test. This test is used to ensure that parameter values in this model, which include both number and graphical relationships, correspond conceptually and numerically to the real system structure. Conceptual correspondence of many of these parameters was easy to verify based upon the literature review. However, several parameters were not easily derived because they were either hypothesized or

literature information was scarce. Numerical correspondence of many parameter values was easily verified with some having to be estimated. The relative uncertainty of the parameters in the model is summarized in Table 3 below. The uncertainty is rated as either low, medium, or high, based upon whether there was adequate, some, or little to no information available for that parameter.

Behavior-Sensitivity Test. This test focuses on sensitivity of model behavior to changes in parameter values. All parameters have been varied to ascertain the impact on model behavior. The results re summarized in Table 3. The corresponding graphs to Table 4 are contained in Appendix G. Model sensitivity is rated as low if changes in the parameter had little or no effect on both the magnitude and shape of output curves. Sensitivity is rated as medium if parameter changes had modest impact on the magnitude of output curves, and little or no impact on the shape of the curves. Sensitivity is rated as high if parameter changes had major impact on the magnitude of output curves and/or caused significant changes in the shape of the curves. The parameters with ratings of high/high are discussed below.

The first parameter to be discussed is the root surface partitioning rate. This parameter, along with the root surface partition coefficient, describes how Pb diffuses to the root and is preferentially bound there due to the cation exchange capacity (CEC) of the root. The unit measure for this parameter is the rate at which the partition coefficient is reached per day. A baseline value of one has been assigned to this parameter. Therefore partitioning, as driven by the magnitude of the partition coefficient, is effectively achieved once per day. This value makes the rate neutral, allowing

diffusion/preferential binding to be characterized by the partition coefficient. This rate is gradually increased to its baseline value over the first days of the growing season and is therefore depicted as a graph. As can be seen in Figures 24 and 25 on the following page, model behavior is highly sensitive to changes in this parameter.

Parameter *(G) denotes graph	Uncertainty	Model Behavior Sensitivity	Figures (Appendix G)
Root Surface Partition Coefficient	Medium	Medium	36 and 37
Root Surface Partition Rate (G)	High	High	24 and 25
Solubility Products	Medium	Low	38 and 39
Precipitation Rates	High	High	26 and 27
Root Surface Precipitation Factor (G)	High	Medium	40 and 41
RFS Fraction	Low	Low	42 and 43
Km	Low	Medium	44 and 45
Vmax	Low	High	46 and 47
Effective Root Mass (G)	Medium	High	48 and 49
Growth/Vmax Retardation Factor	Medium	Low	50 and 51
Xylem CEC Goal	High	Low	52 and 53
Xylem CEC Factors (G)	Medium	Low	54 and 55
Plant Tissue/Xylem Fractions	Low	Low	56 and 57
Plant Tissue/Phloem Fractions	Low	Low	58 and 59
Stem Xylem Flow Tsp Fractions	Medium	Low	60 and 61
Xylem-Phloem Transfer Fractions	Medium	Low	62 and 63
Maximum Phloem Flow Rate	Medium	Low	64 and 65
Transfer Rate Coefficient	High	Low	30 and 31
Plant Dry Mass Fractions (G)	Low	Low	66 and 67
Maximum Shoots Dry Mass (G)	Low	Medium	68 and 69
Shoots and Root Water Fractions (G)	Low	Medium	70 and 71
Shoots to Root Ratio (G)	Low	Medium	72 and 73
Transpiration Production and Maintenance Factors (G)	High	Medium	74 and 75
Transpiration Coefficient	Low	Medium	76 and 77

Table 3 – Model Parameter Uncertainty and Behavior Sensitivity

Both figures show that increasing the partitioning rate has no significant impact on model behavior, but decreasing the rate changes the shape of the curve dramatically. This anomaly can be explained by the reduced preferential binding at the root surface and RCA during periods when transpiration is reaching its highest values. Since there is less

Root Surface Partition Rate (Graph) – Trace 1 – 1.0 (baseline), trace 2 – 0.2, trace 3 – 5.0.

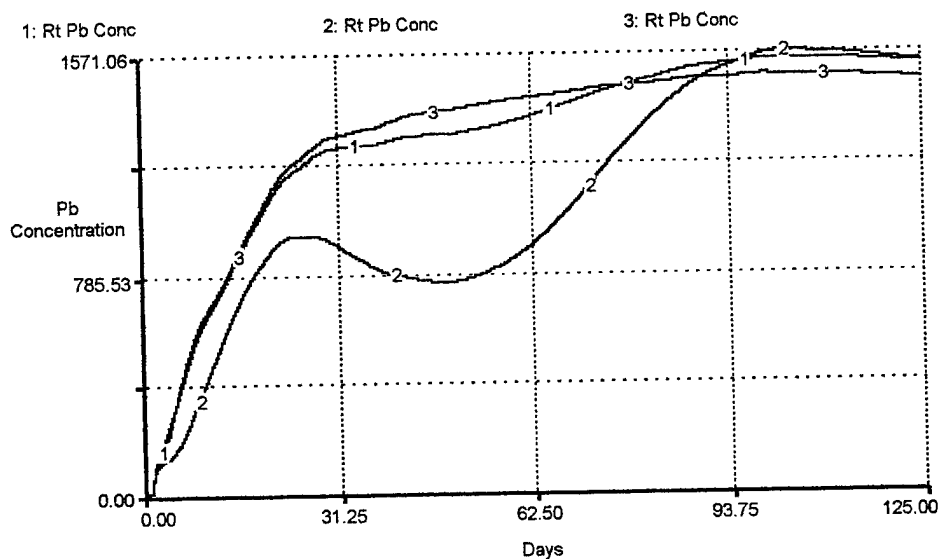

Figure 24 – Root concentration varying root surface partition rates

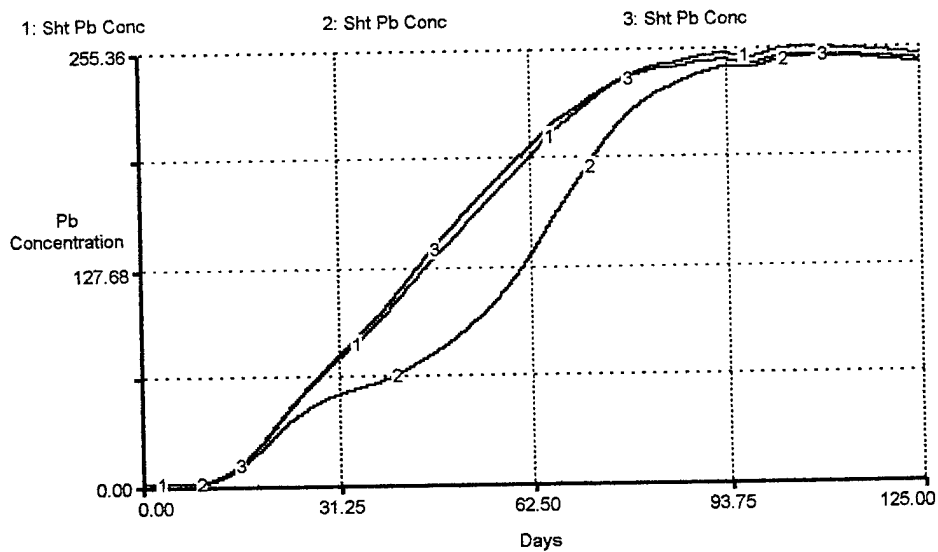

Figure 25 – Shoots concentration varying root surface partition rate

binding, the concentration in the vicinity of uptake sites is decreased and therefore uptake decreases. Additionally, this time frame is when plant growth is the greatest. These two factors together would appear to account for the decreased plant concentrations during this time frame.

The other parameter to be discussed is the precipitation rate. This parameter is the rate at which the Pb-phosphate reaction reaches equilibrium per day. As can be seen from Figures 26 and 27, this parameter has a dramatic impact on model behavior. Decreasing precipitation rate increases the shoot Pb concentration and decreases the root Pb concentration, and increasing the rate has the opposite effect. This behavior can be explained by the fact that the faster precipitation occurs, the more it builds up at its point of entry into the system -- the root. As more precipitates in the root, less is available for translocation to the shoots.

The baseline precipitation rate was established based upon two observations from outside research. The first is the apparent rapid rate at which precipitation appears to occur as observed by Malone and others (1974: 388-394). The second is the empirical observations of many researchers, and especially Huang and Cunningham (1996: 75-84), that Pb concentration in maize roots is about 5-10 times as high as in the shoots. Ensuring that the rate was in agreement with the first observation, it was adjusted to a baseline value of five to allow model behavior to match the second observation.

Precipitation Rates – Trace 1 - 0.2, trace 2 - 1.0, trace 3 - 5.0, trace 4 - 10.0.

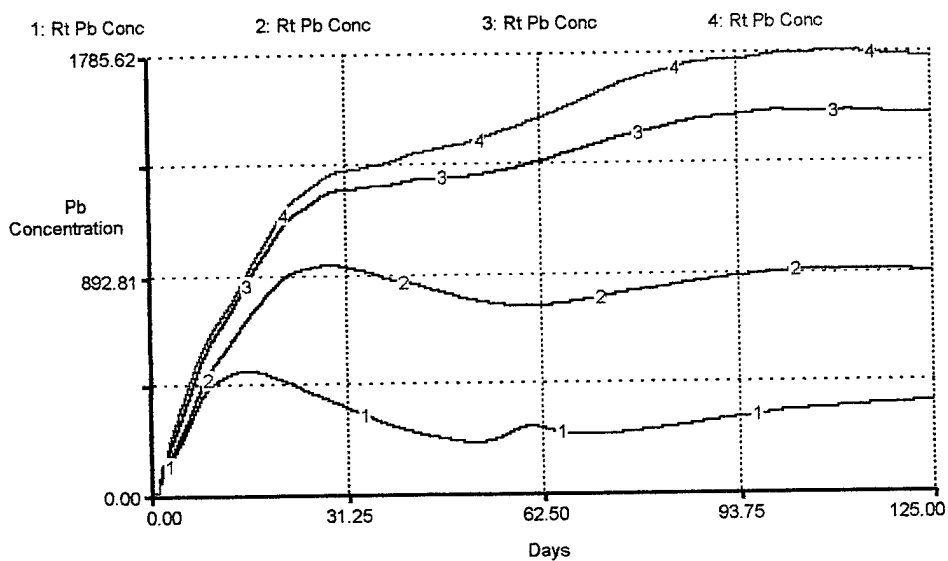

Figure 26 - Root concentrations varying precipitation rates

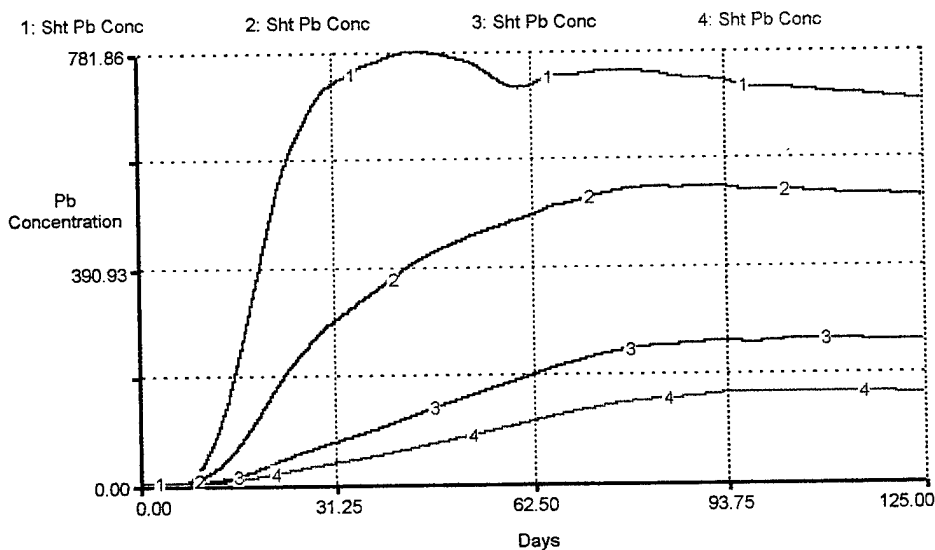

Figure 27 – Shoot concentration varying precipitation rates

Extreme-Conditions Test. In this test extreme values of parameters or variables are plugged into the model to test model behavior. All of the internal system parameters have been tested as discussed in the previous section. The results of varying the one external environmental parameter, Pb concentration in soil solution, to the extremes are discussed below.

Figures 28 and 29 show how the Pb concentrations increase in the root as Pb concentrations in soil solution are increased. Lead concentrations in the shoots also increase initially, but once the soil concentration exceeds 4 mg/liter shoot concentrations begin to decrease. This anomaly in shoot Pb concentrations can be explained by the retardation in plant growth, and the corresponding decrease in V_{max} , that occur at these high concentrations. This means that less Pb is taken into the plant and therefore less is available for translocation to the shoots. On the other hand, root concentrations continue to increase because of precipitation at the root surface and RCA.

Behavior-Anomaly Test. This test is used to examine anomalies in model behavior, and determine if they are related to flaws in model structure or assumptions. This test has already been applied in the previous section and has been used throughout the model development process. It will now be applied to two apparent aberrations in the baseline model output characteristics.

As seen in Figure 21, Pb concentration in the root builds up rapidly initially (through about day 30) and then begins to level off sooner than in the shoots. This anomaly is caused by the initial rapid buildup of Pb-precipitate at the root surface/RCA and in the root tissue. Only Pb that is not precipitated is available for translocation to the

shoots. Since this is small, and because xylem flow rates are initially very low, Pb concentration in the shoots builds up slowly as it is translocated. Hence the gradual increase in Pb concentration in the shoots in contrast to the rapid initial increase in Pb concentration in the root.

The second apparent anomaly occurs about day 100 in the shoot concentration as seen in Figure 21. A slight dip and recovery can be seen. This is caused by a rough section in the graph that defines the shoot to root ratio. These graphs are hand-drawn, and as can be seen from Figure 73 where this graph was redrawn for each of the curves shown in the figure, the little bump is either inverted or disappears.

Phytoextraction Management Scenarios

This model appears to be a valuable tool for gaining insights into the mechanisms controlling uptake and translocation of Pb. It can also be used to suggest time frames when maize is most productive at translocating Pb from roots to shoots. This information could be useful in management of the phytoextraction process, assisting managers in determining the optimum time frame for harvesting plants. Recognizing that uptake and translocation of Pb-chelates may work through different mechanisms, it could also assist in making decisions concerning when to apply chelates to increase soil solution Pb.

Table 4 below tabulates the simulation results of total accumulation of Pb in maize shoots, and accumulation during distinct 15-day periods throughout the growing season. As can be seen from the table, it appears that after day 75 the rate of Pb accumulation in the shoots declines, even though it remains quite high through day 90. Keeping in mind that the goal of most phytoextraction managers would be to harvest

Soil Solution – Trace 1 - 0.04, trace 2 - 0.4, trace 3 – 4.0 (baseline), trace 4 – 40, trace 5 -100.

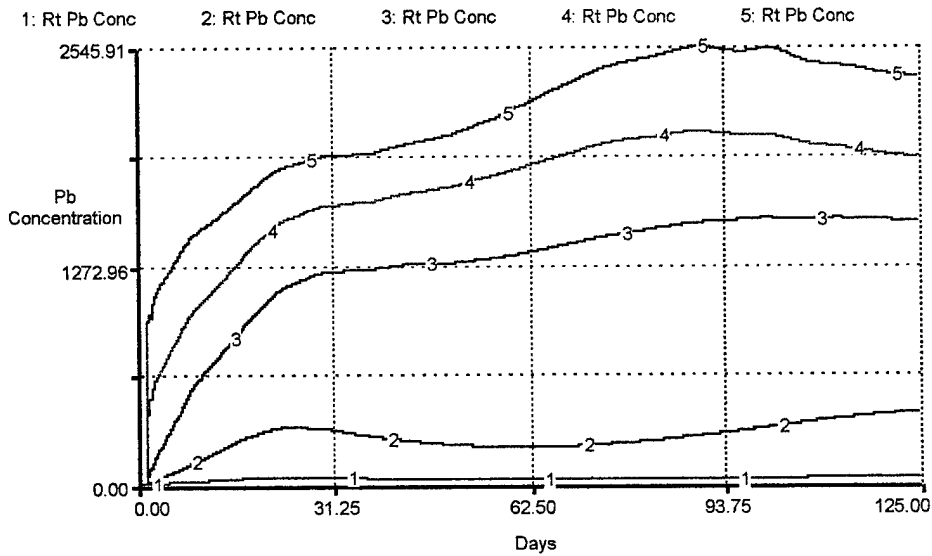

Figure 28 – Root concentration for Pb concentration in soil solution

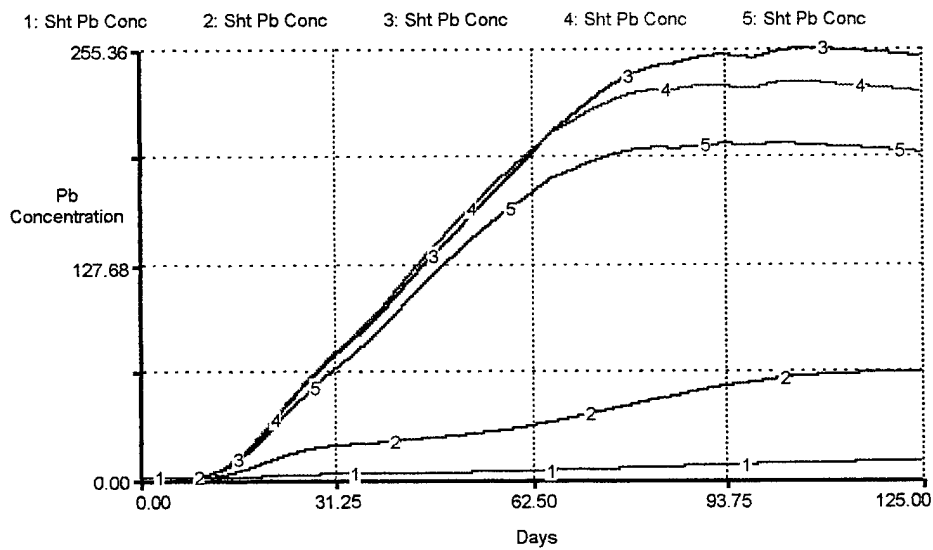

Figure 29 – Shoot concentrations varying Pb concentrations in soil solution

plants two times in a summer season (Cunningham, 1997: personal communication), the results suggest that harvesting after day 75 may be the best alternative.

Growing Season Period (days)	Total Pb in Shoots (mg)	Pb Accumulated in Period (mg)
0-15	0.03	0.03
16-30	0.97	0.94
31-45	5.92	3.95
46-60	20.24	14.32
61-75	43.77	23.53
76-90	64.13	20.36
91-105	75.88	11.75
105-125	79.87	3.99

Table 4 – Shoot accumulations of Pb during the growing season

Application of chelates such as EDTA to soil dramatically increases Pb concentrations in soil solution. This greatly increases uptake of Pb but soon leads to plant death. This model can be used to simulate surges in soil solution concentrations of Pb caused by the addition of chelates and the resulting accumulation of Pb in plant shoots. This simulation was conducted for selected periods during the growing season where the Pb concentration in soil solution was surged from 0.1 to 200 mg/liter on the given day. The results are contained in Table 5.

Growing Season Period After Pb Surge (days)	Surge in Pb Concentration Soil Solution (day)	Total Pb in Shoots at end of Growing Period (mg)
20-35	20	1.18
35-50	35	6.20
50-65	50	13.79
65-80	65	13.45
80-95	80	9.12

Table 5 – Shoot accumulations surging Pb concentration in soil solution

As can be seen from the table, it appears that day 50 may be an optimum day for applying chelates to surge Pb concentrations in soil solution with plants being harvested on day 65. This is slightly different than the time frame that was implied from Table 4. It suggests that a maize plant may accumulate Pb in its shoots slightly differently when Pb soil solution concentrations are surged. This difference is most likely caused by differences in plant growth and retardation of V_{max} . When Pb concentration is surged, plant growth and V_{max} are not retarded until the day when the concentration is surged. Therefore, in at least the initial days after surging Pb concentration, uptake will be much more efficient. On the other hand, where Pb concentration is held constant throughout the season, plant growth and V_{max} values are both being affected from the beginning.

The results above could be meaningful and useful to people who are managing the phytoextraction process. They are but a few of the scenarios that can be explored with this model demonstrating some of its potential phytoextraction management applications.

5. Conclusions and Recommendations

The purpose of this research effort has been to build a model that simulates a plant soil system with regards to uptake and translocation of Pb. The intent has been to gain insights into the mechanisms that control uptake and translocation of Pb, and how these mechanisms interact to control accumulation of Pb in the roots and shoots of a plant. These insights are intended to be useful to phytoextraction managers.

A model has been constructed that appears to provide a reasonable simulation of the system of interest. As with any model, its validity rests upon many assumptions and should be viewed in light of its intended purpose. Tremendous insights have been gained concerning this system through model construction, testing, and application. The insights gained from this effort are summarized in the first section as answers to the research questions. The second section contains a brief summary of the apparent strengths and limitations of this model. The final section contains recommendations concerning use of the systems dynamics approach, areas for further study, and how to make experimentation and modeling more compatible.

Answers to Research Questions

What are the mechanisms within a plant that control uptake of Pb from soil? The mechanisms that appear to control uptake of Pb are (further presented in Chapter 4):

1. Movement of Pb from soil solution to the root surface and RCA.
2. Activities affecting the concentration of Pb at the root surface/RCA.
3. Movement of Pb into the root symplast.

What are the mechanisms within a plant that control the translocation of Pb from roots to shoots? There appears to be seven mechanisms that control translocation of Pb from roots to shoots. These mechanisms are (further discussed in Chapter 4):

1. Precipitation of Pb in the root tissue.
2. Movement of Pb from the root tissue to the xylem.
3. Movement of Pb in the xylem from the roots to the shoots.
4. Movement from the xylem into the shoot tissue.
5. Precipitation in the shoot tissue.
6. Movement of Pb into the shoot phloem from the tissue.
7. Movement in the shoot phloem to the roots.

How do the mechanisms that control uptake and translocation feedback upon each other to determine levels of Pb accumulation in the roots and the shoots? The most important feedback relationships between uptake and translocation mechanisms are as follows:

1. The rate of movement of Pb from the soil solution to the root surface and RCA and the preferential binding there. These have a significant impact upon the amount of Pb taken up into the root symplast.
2. Since there are assumed to be no exits of Pb from the maize plant once it enters, and since the only point of entry into the plant is through the roots, the amount of Pb taken into the root symplast controls the amount of Pb available for translocation to the shoots.
3. The more Pb a maize plant takes into its roots, the greater the retardation of

both plant growth and maximal uptake values (V_{max}). This in turn feeds back and causes decreased uptake into the root symplast.

Which plant mechanisms are most important in determining the levels of Pb that will accumulate in the shoots and thus be readily available for phytoextraction? The most important mechanisms appear to be:

1. The precipitation of Pb in the roots and shoots of the plant. The parameter that appears to have the greatest impact upon precipitation is the precipitation rate.
2. The uptake of Pb into the root symplast. The most important parameters are the maximal uptake rates (V_{max}) of Pb, the affinity of the plant (K_m) for Pb, and the effective root mass of the plant.

How do levels of Pb accumulation vary as levels of input for different mechanisms, and the magnitude of feedback between mechanisms, are varied? This question is best answered by referring to Table 3 and Figures 24 and 25.

What time frames may be the best for harvesting plants or applying chelates in the phytoextraction process? Refer to Tables 5 and 6 and the corresponding discussion in the previous chapter.

Model Strengths and Limitations

Model Strengths

1. Provides information and insights concerning time dependent behavior of the system over the course of an entire growing season.
2. Ties together information and empirical data from many different sources, providing

a comprehensive view of the system.

3. Suggests areas for research and experimentation that may be key to making the phytoextraction process viable without synthetic chelates.

Model Limitations

1. Rests upon many assumptions, many of which are untested.
2. Characterization of Pb movement from soil solution to root surface, and retention there due to preferential binding, is simplistic.
3. Many parameter values are moderately or highly uncertain.

Recommendations

Use of the System Dynamics Approach. As previously discussed, the system dynamics approach was not strictly adhered to in all phases of model development. Specifically, a departure was made from this approach by initially choosing to construct a model with significant detail rather than building a less detailed model as guided by the reference mode, and adding detail to areas to which model behavior is highly sensitive. This departure had the advantage of forcing me to become intimately familiar with the mechanisms that had been identified in the literature and learning how they all fit together in the system. However, it had the disadvantage of not forcing me to focus on those mechanisms that were driving system behavior, the reference mode, during the initial stages of model development. If the system dynamics approach had been strictly followed, it is unlikely that the initial model behavior would not have matched the reference mode, such as happened in this case. A second disadvantage is that not strictly adhering to the system dynamics approach may have caused me to be much more

inefficient in my research. A proper focus on the reference mode may have reduced or prevented the time spent on researching mechanisms that had very little impact on model behavior.

Keeping the above discussion in mind, the recommendation here is to carefully weigh the possible advantages and disadvantages before departing from strict adherence to the system dynamics approach.

Further Research. The first recommendation concerns the assumed Pb precipitation reactions at the root surface and throughout the plant. If precipitation occurs as it has been assumed, it clearly plays a major role in how much Pb will be taken up into the roots and translocated to the shoots. Can precipitation in the tissue be described as an equilibrium reaction in aqueous solution limited by phosphate availability? Does precipitation significantly affect phosphate levels in the plant? These questions should be closely scrutinized, and if possible verified or refuted by experimental research. Experimental research concerning this phenomena has not appeared in the literature since the 1970's (Malone and others, 1974: 388-392).

The second recommendation would be to examine the hypothesized phenomena of decreasing maximal Pb uptake rates (V_{max}) with increasing levels of Pb. Does Pb really block uptake channels? If so, how much does it retard Pb uptake? Should it be linked to plant growth retardation or should it be separate? This hypothesized mechanism may have much greater impact on Pb uptake than I have proposed in this research, and certainly merits closer examination.

Movement of Pb to the root surface and preferential binding of Pb there due to

CEC of the root also has a major impact on uptake of Pb. The description of this phenomena has considerable uncertainty and impact on model behavior, and should therefore be studied more closely. Works of other researchers in this area could also be tied into this portion of the model and perhaps greatly reduce the level of model uncertainty.

Declining effective root mass for the uptake of Pb is another mechanism that appears to be supported by the work of other researchers, but the magnitude of its effect is uncertain. Additional research is certainly warranted on this postulated mechanism.

Finally, the model that has been developed here establishes a foundation for the construction of a model to describe uptake and translocation of Pb-chelates from soil. The insights gained from this model, and much of the model structure, could be modified to formulate the new model. The resulting work could have tremendous applications for the field of phytoextraction.

How to make modeling and experiments more compatible. The dawning of the computer age has opened tremendous doors for learning. Some of the best opportunities are in the area of computer modeling and simulation. Models and simulations can offer insights on how a system may work under conditions that are expensive or difficult to replicate under experimental conditions. However, models usually require at least some experimental data in order to be initially formulated. Unfortunately, most data is in a form that is not easily used for modeling. For example, there is very little data that can be used to characterize xylem and phloem flow rates, daily transpiration rates, and xylem, phloem, and tissue mass fractions. Therefore methods have to be improvised

using the limited useful research data to develop methods to characterize phenomena such as transpiration, as was done in this model.

Experiments should be designed and presented keeping in mind how they may be integrated with the needs of the modeling and simulation community. Results of experiments conducted in this fashion will not only have value in and of their own right, but will be also be of great use to modelers. In this manner experimental research and modeling efforts will be synergistic and should result in great gains in knowledge in fields such as phytoextraction.

Appendix A – Model Flow Diagram

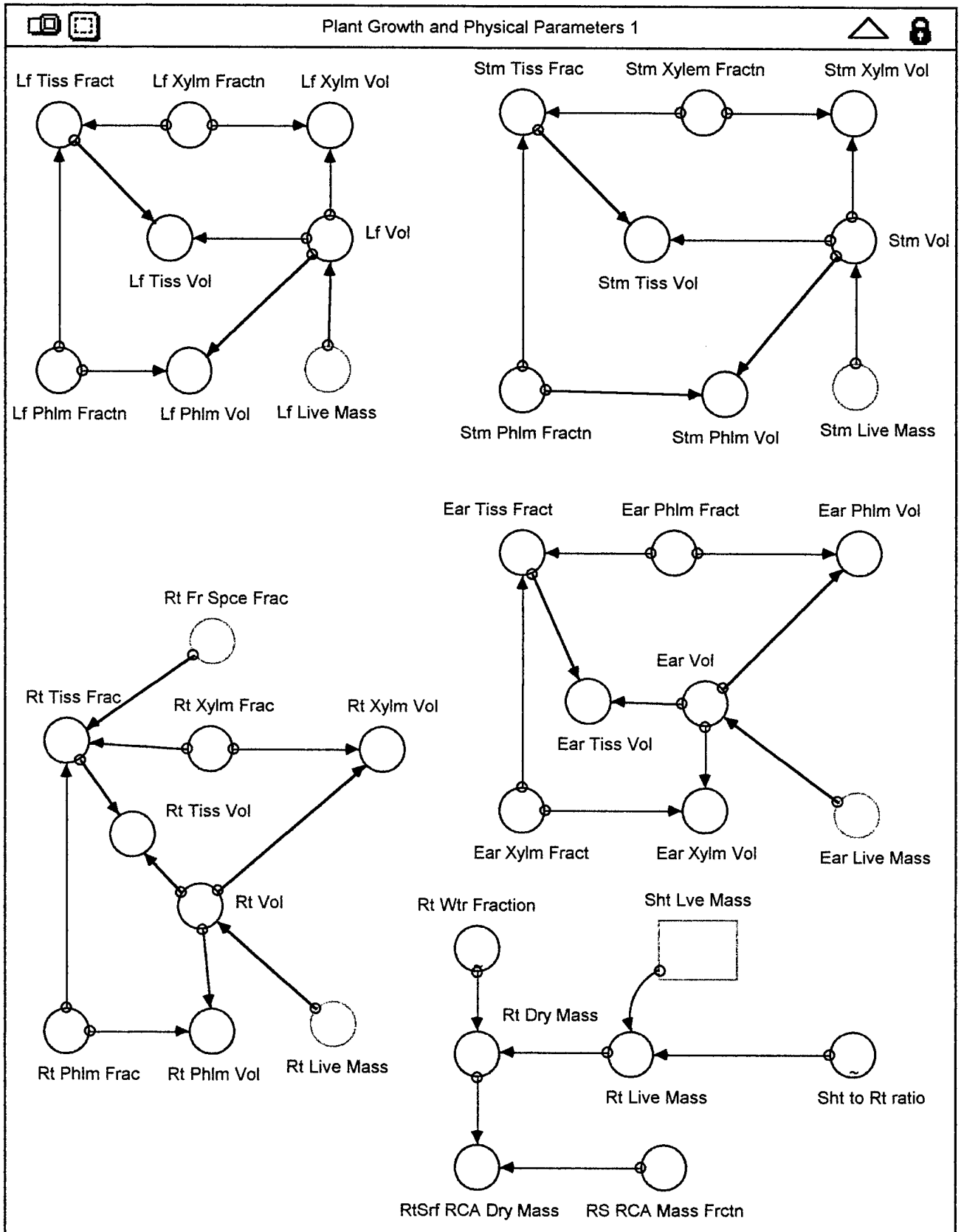

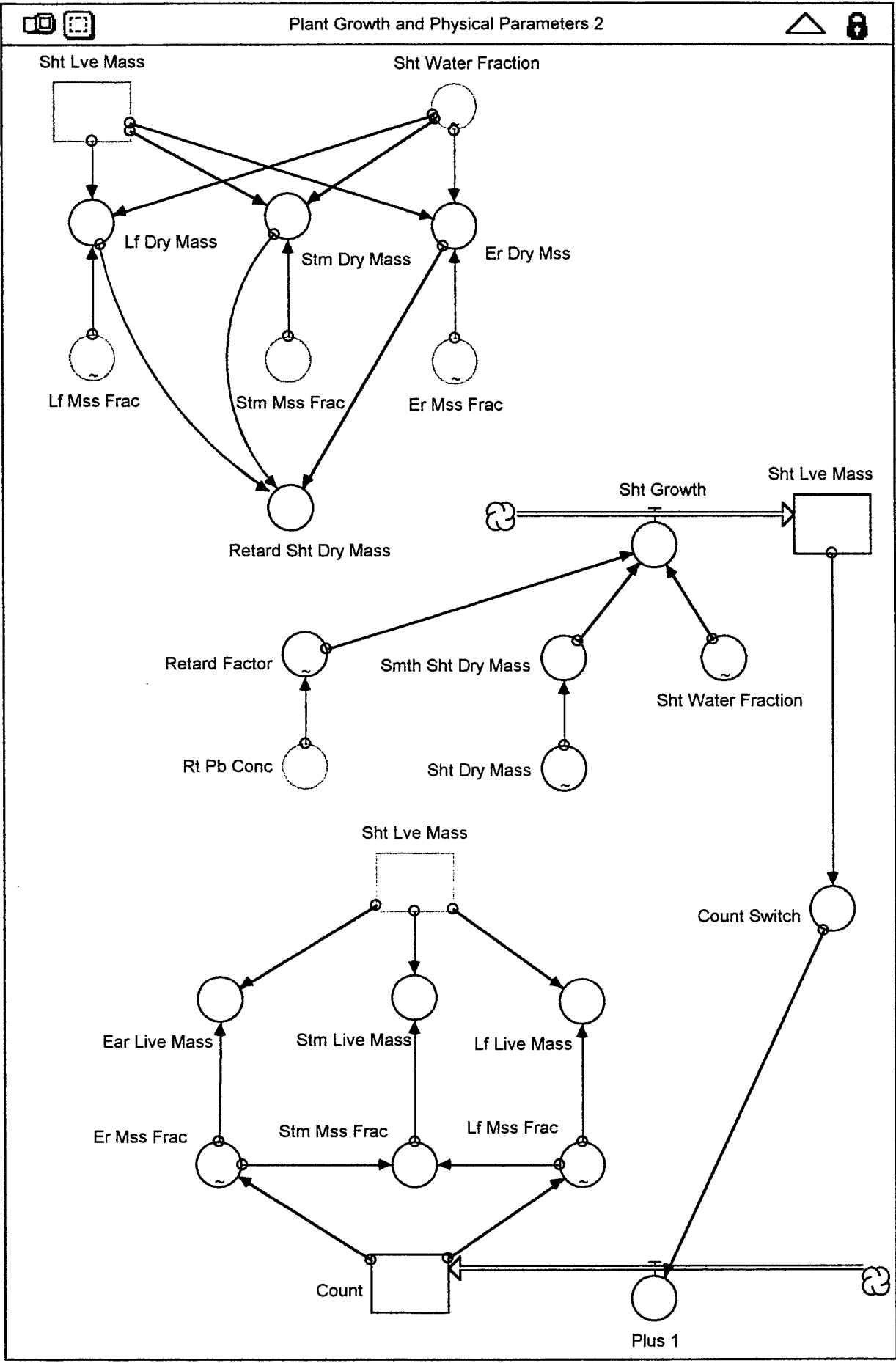

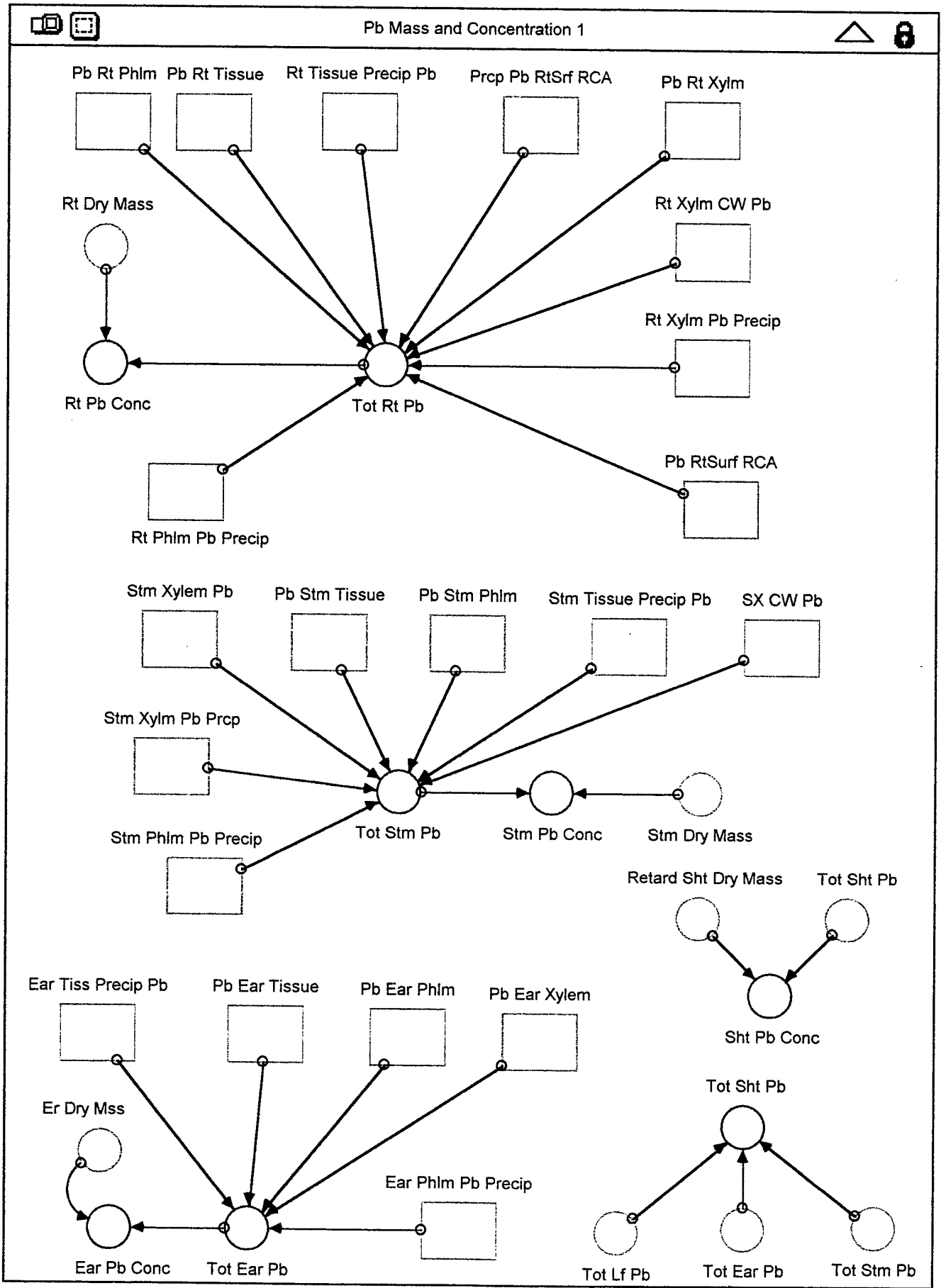

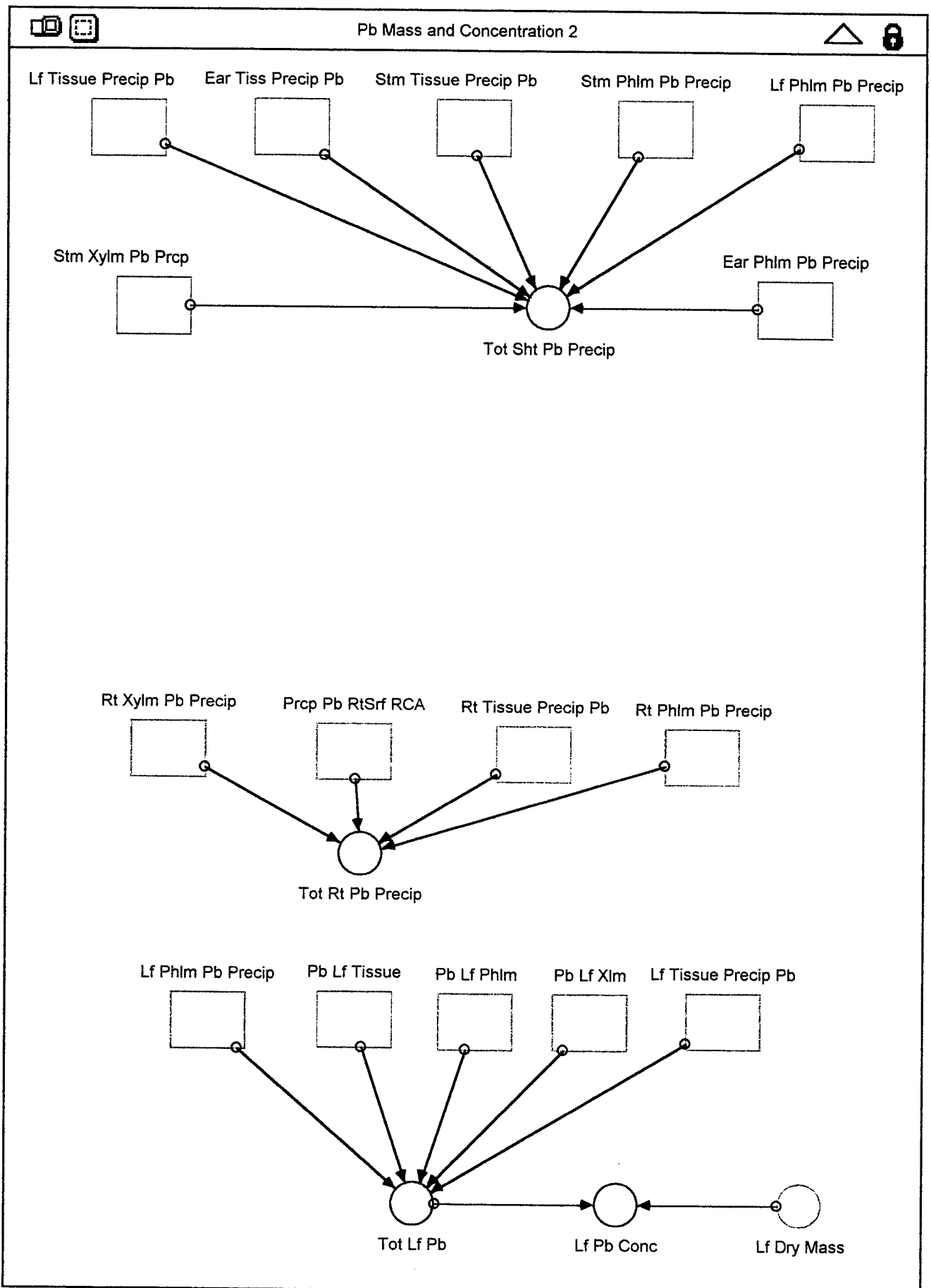

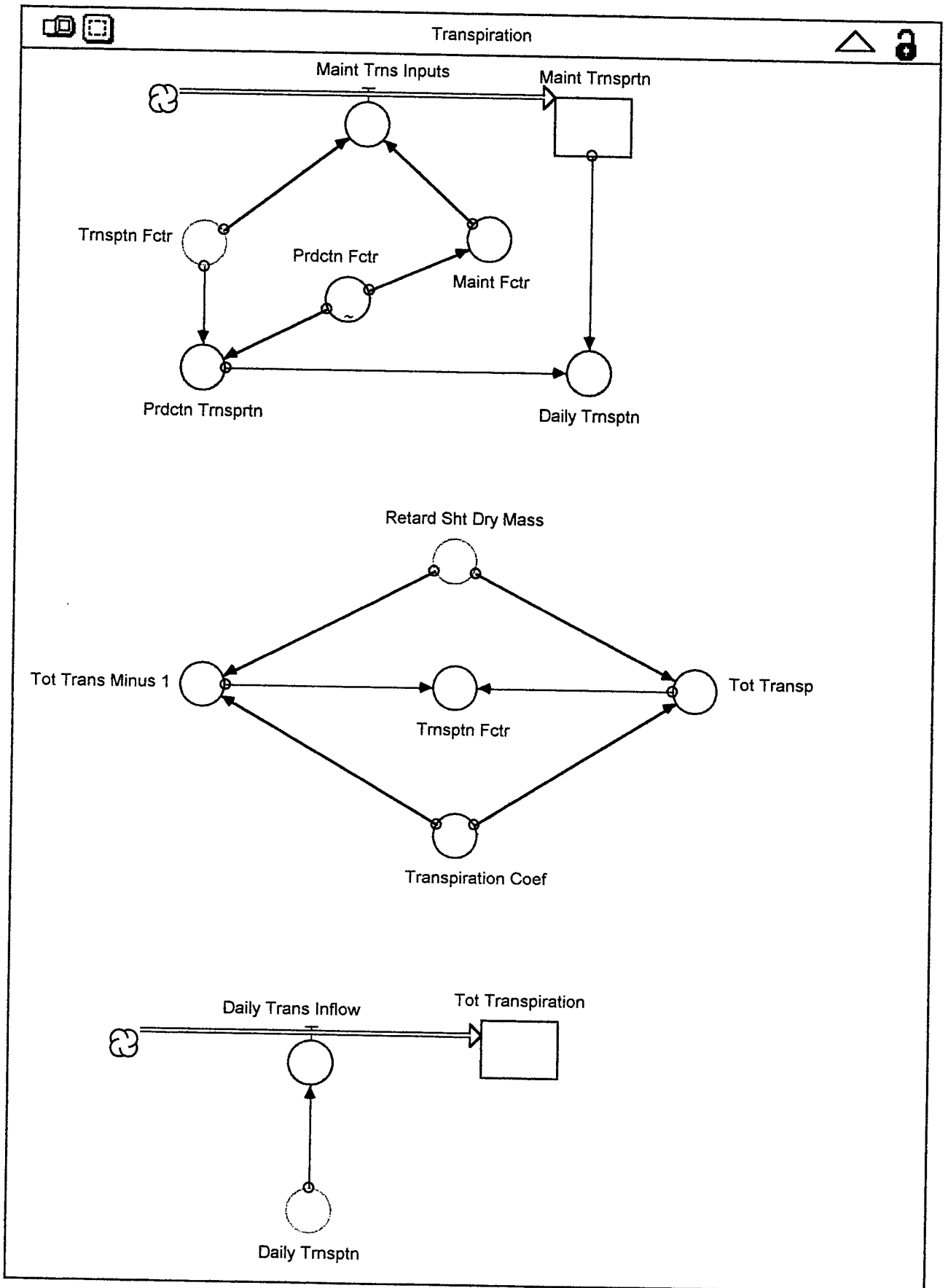

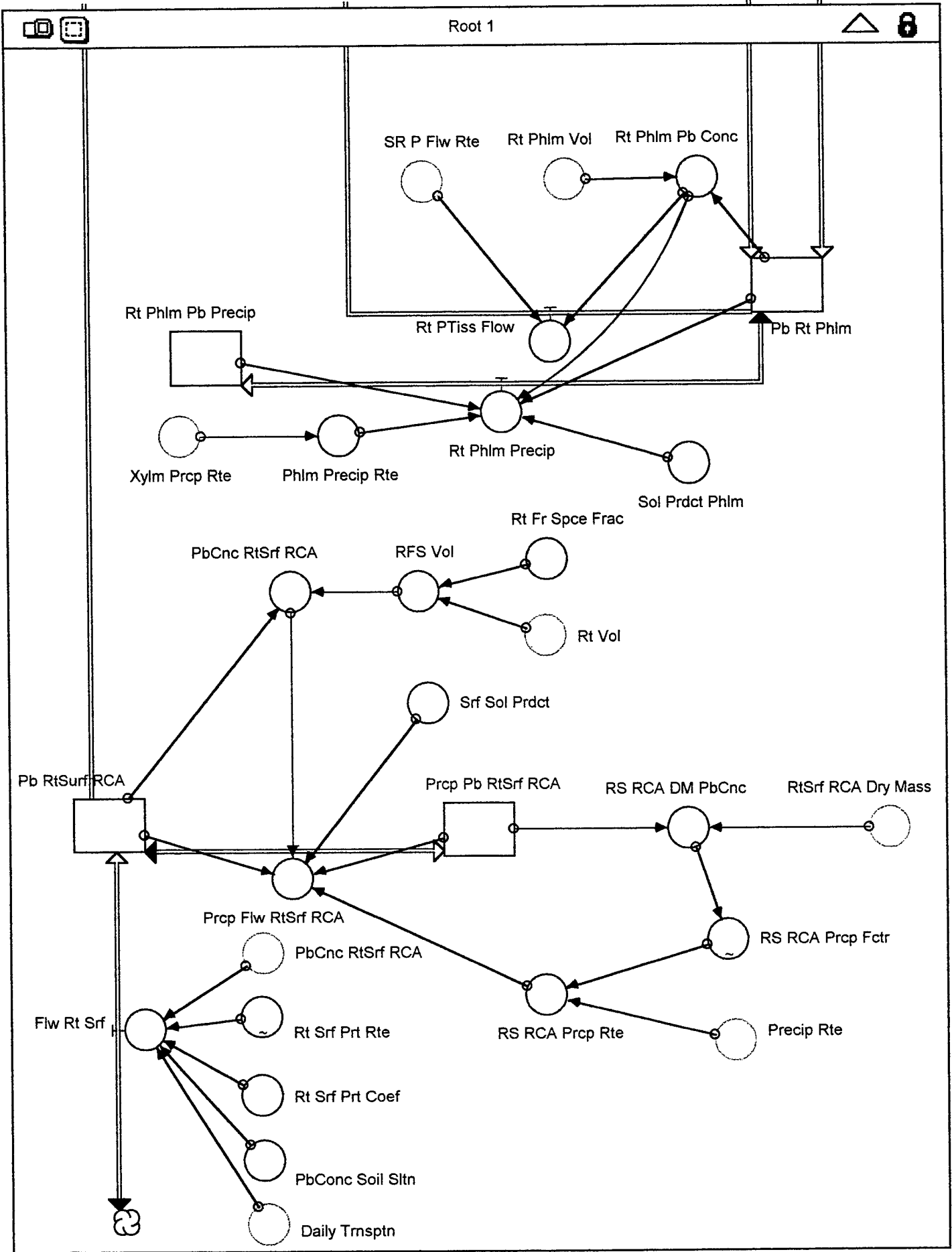

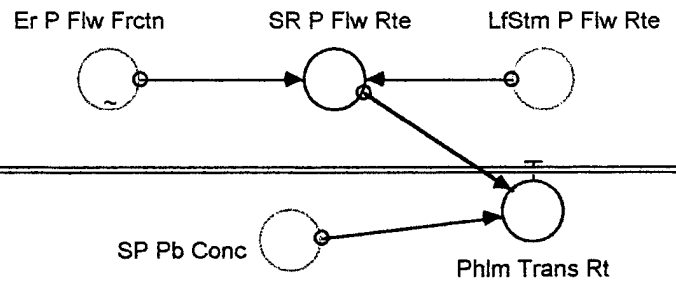
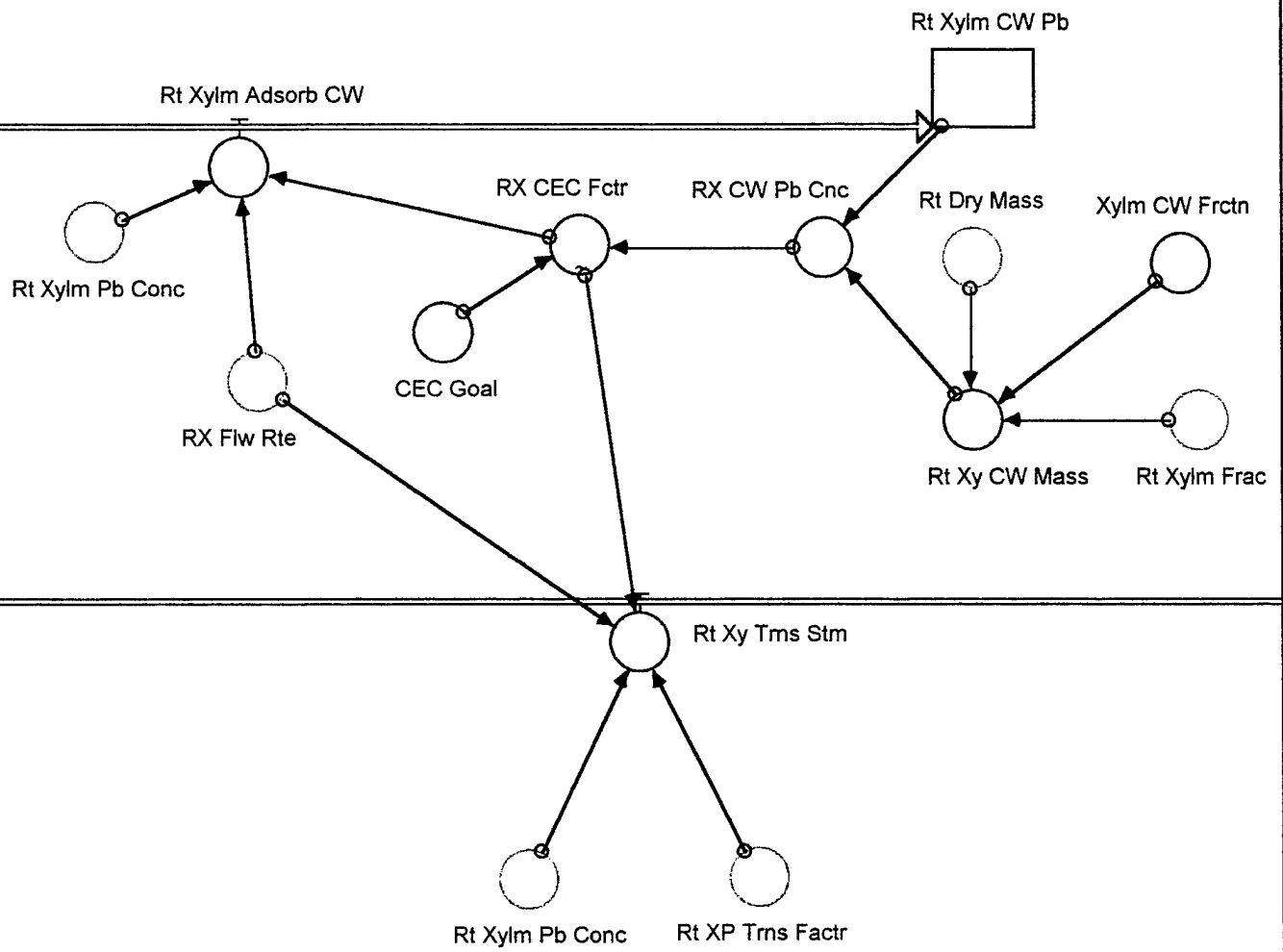

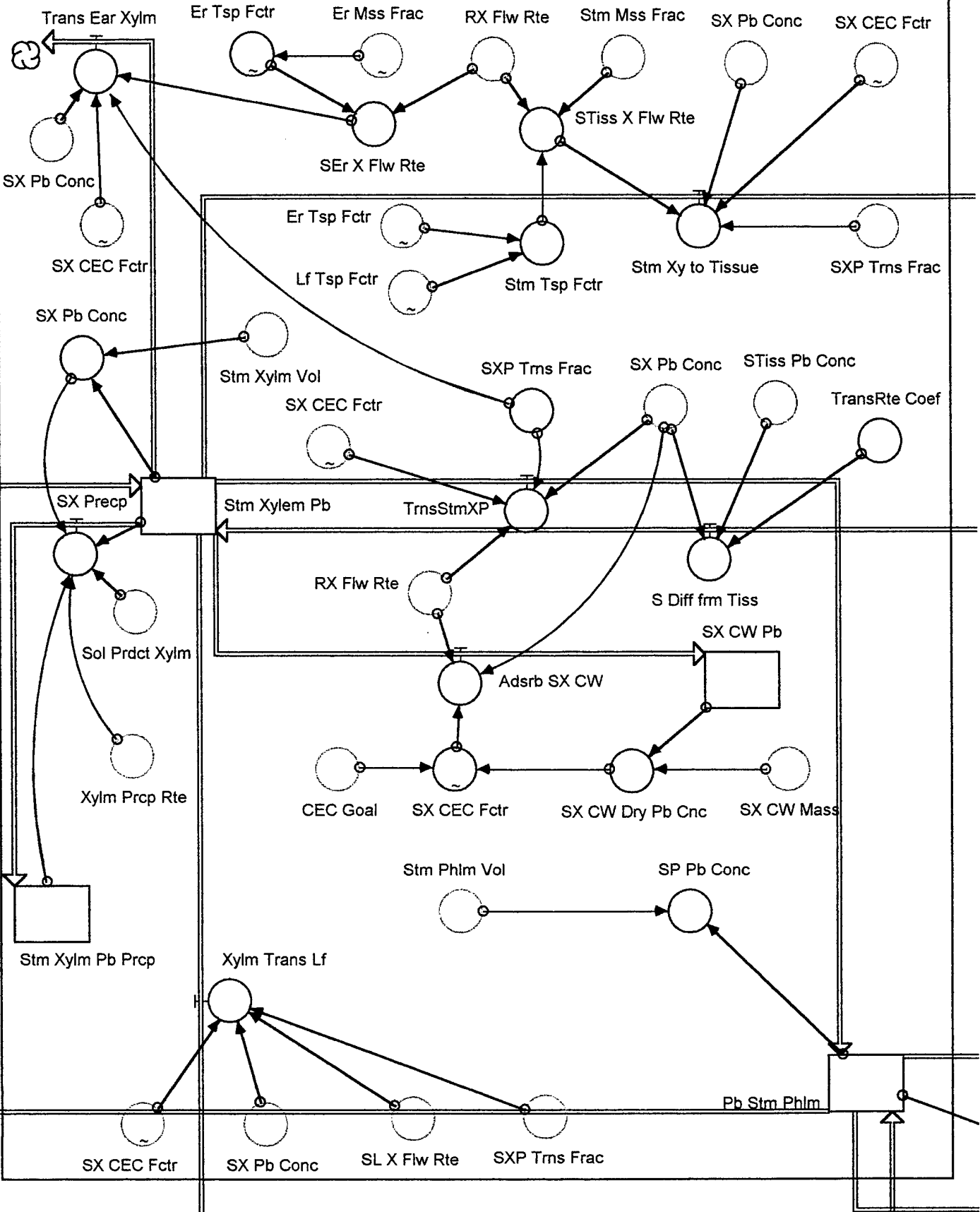

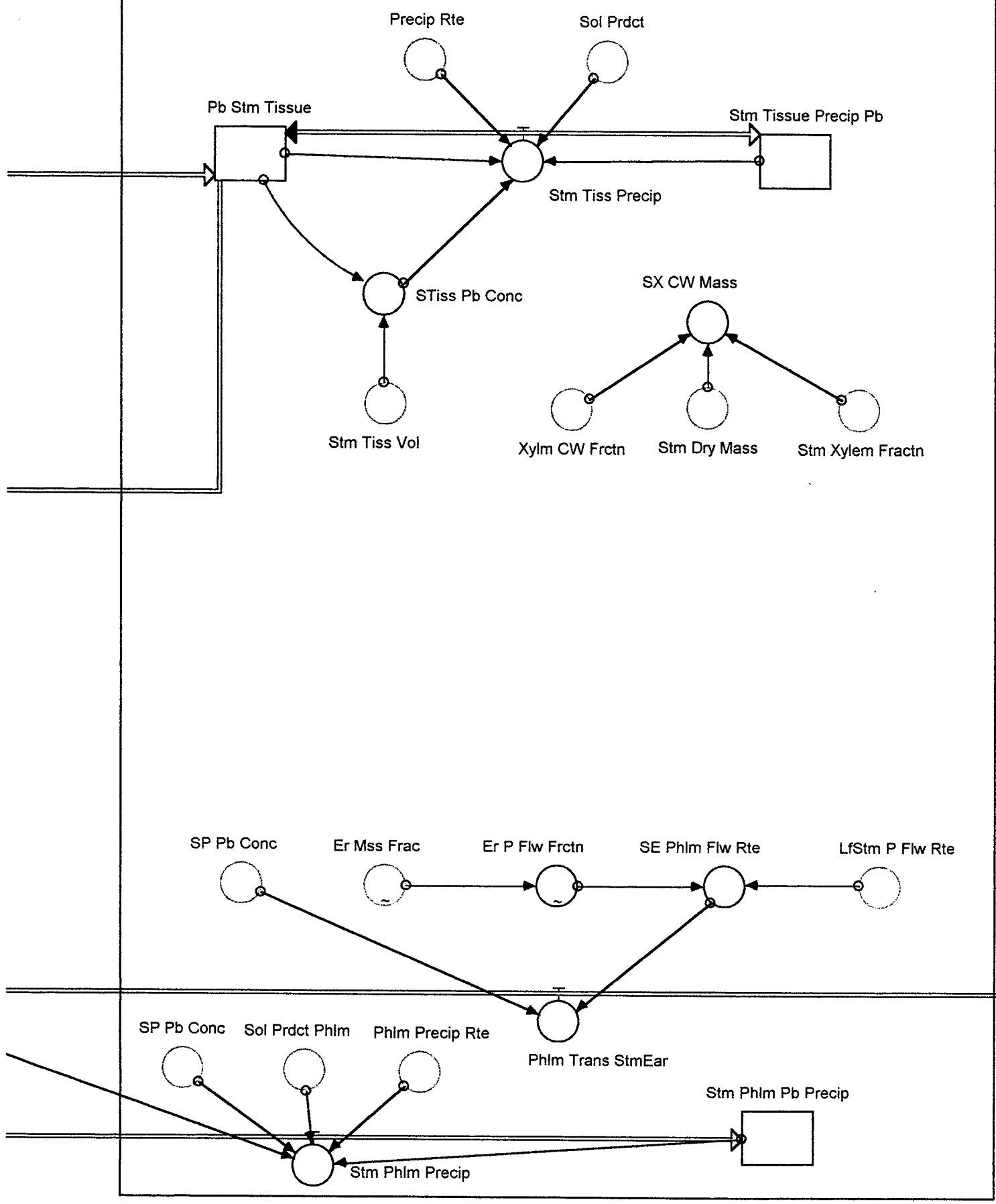

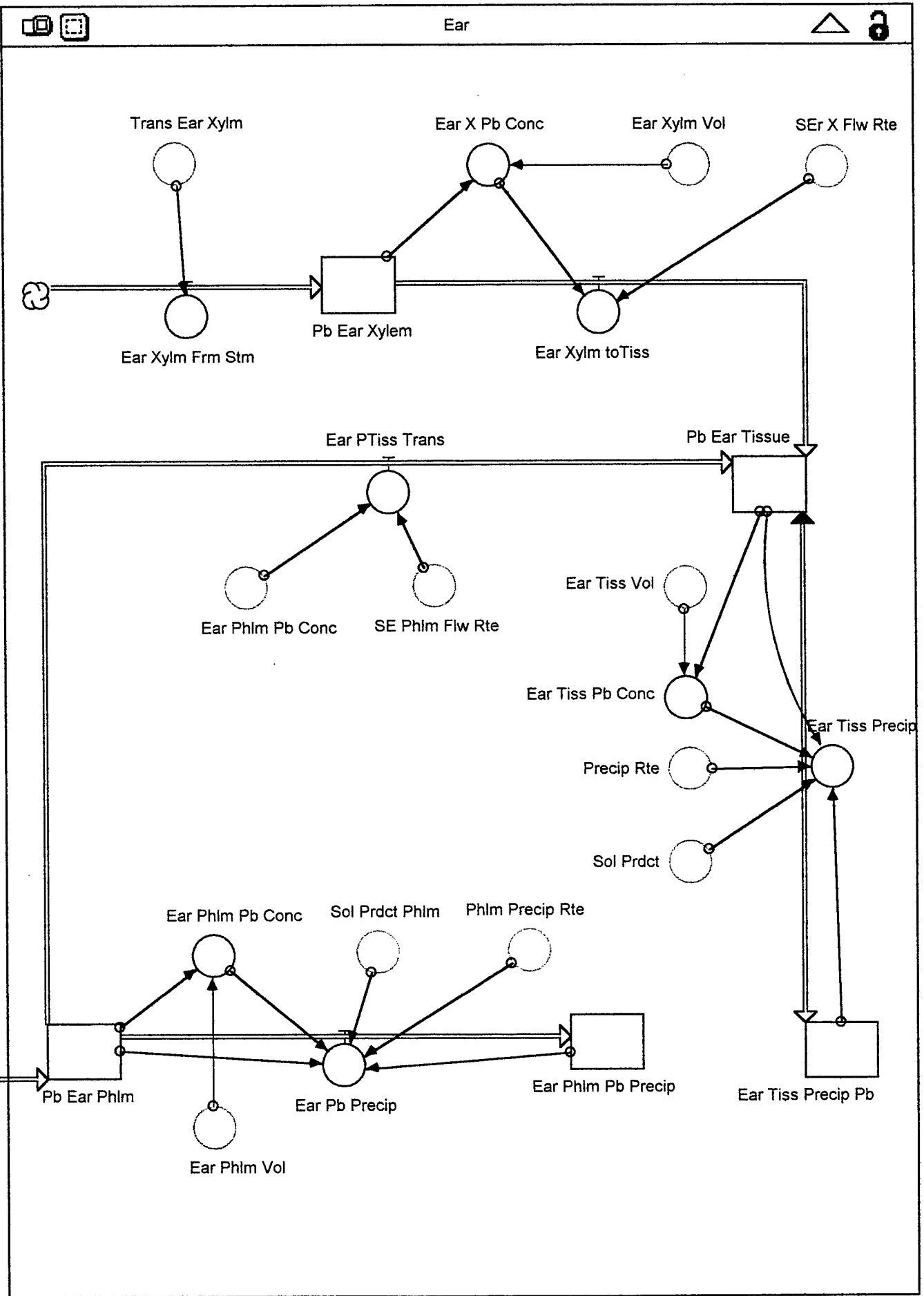

Appendix B – Model Equations and Code

Leaf Sector

Stock

$Lf_Phlm_Pb_Precip(t) = Lf_Phlm_Pb_Precip(t - dt) + (Lf_Plhm_Precip) * dt$

INIT $Lf_Phlm_Pb_Precip = 0$

DOCUMENT: This is the amount of Pb that is precipitated in the phloem of the leaf.

Units: mg of Pb

Inflows

$Lf_Plhm_Precip = IF(Lf_Phlm_Pb_Conc > Sol_Prdct_Phlm)$

THEN($((Lf_Phlm_Pb_Conc - Sol_Prdct_Phlm) / Lf_Phlm_Pb_Conc) * Pb_Lf_Phlm * Phlm_Precip_Rte$)

ELSE($((Lf_Phlm_Pb_Conc - Sol_Prdct_Phlm) / Sol_Prdct_Phlm) * Lf_Phlm_Pb_Precip * Phlm_Precip_Rte$)

DOCUMENT: This is the precipitation and or solubilization of Pb in the leaf phloem. If the solution in the leaf phloem is supersaturated, then some Pb will precipitate. If it is undersaturated, then some will solubilize. It is assumed that the amount that is precipitating or solubilizing is dependent upon the amount of Pb in precipitate or solution, the rate of precipitation, the total solubility of Pb at pH 8.0, the concentration of Pb in solution, and the concentration of free phosphate in the leaf phloem (which is assumed to be 0.0001 molar). It is also assumed that the dominant form of precipitate will be an amorphous Pb-phosphate (Malone and others, 1974: 388).

Units: mg/day

Stock

$Lf_Tissue_Precip_Pb(t) = Lf_Tissue_Precip_Pb(t - dt) + (Precip_Lf) * dt$

INIT $Lf_Tissue_Precip_Pb = 0$

DOCUMENT: The total amount of Pb that has been precipitated in the leaf tissue (symplast (excepting phloem) or apoplast (excepting xylem)). If it precipitates in the symplast, it assumed that it will be moved outside of the symplast and into the apoplast, being deposited in the cell wall (Malone and others, 1974: 391).

Units: mg of Pb

Inflows

$Precip_Lf = IF(Lf_Tiss_Pb_Conc > Sol_Prdct) THEN(((Lf_Tiss_Pb_Conc - Sol_Prdct) / Lf_Tiss_Pb_Conc) * Pb_Lf_Tissue * Precip_Rte)$

ELSE($((Lf_Tiss_Pb_Conc - Sol_Prdct) / Sol_Prdct) * Lf_Tissue_Precip_Pb * Precip_Rte$)

DOCUMENT: This is the precipitation and or solubilization of Pb in the leaf tissue. If the solution in the leaf tissue is supersaturated, then some Pb will precipitate. If it is undersaturated, then some will solubilize. It is assumed that the amount that is precipitating or solubilizing is dependent upon the amount of Pb in precipitate or solution, the rate of precipitation, the total solubility of Pb at pH 7, the concentration of Pb in solution, and the concentration of free phosphate in the leaf tissue (which is assumed to be 0.0001 molar). It

is also assumed that the dominant form of precipitate will be an amorphous Pb-phosphate (Malone and others, 1974: 388).
Units: mg/day

Stock

$Pb_Lf_Phlm(t) = Pb_Lf_Phlm(t - dt) + (Lf_TissPFlw - P_Trans_LfStm - Lf_Plhm_Precip) * dt$

INIT $Pb_Lf_Phlm = 0$

DOCUMENT: The mass of Pb in the leaf phloem.

Units: mg

Inflows

$Lf_TissPFlw = Lf_TissP_Flw_Rte * Lf_Tiss_Pb_Conc$

DOCUMENT: The flow of Pb that is going out of the leaf tissue and into the leaf the phloem. It is assumed that phloem flow will be from source to sink in accordance with the Munch hypothesis, with the flow being driven by the amount of photosynthate in these sources and sinks (Marschner, 1983:20-24), (Salisbury and Ross, 1992: 164 and 181), (Kochian, 1991: 249), and (Marschner, 1986: 87). The primary source for photosynthate, and thus phloem flow, is mature leaves, and the primary sinks the roots and ear. It is assumed that Pb will move in the same direction and at the same rate as the phloem flow of photosynthate. The flow that moves from the leaf tissue to the leaf phloem is the product of the soluble Pb tissue concentration and the flow rate out of the tissue.

Units: mg of Pb/day

Outflows

$P_Trans_LfStm = Lf_Phlm_Pb_Conc * LfStm_P_Flw_Rte$

DOCUMENT: The flow in the phloem of Pb from the leaf to the stem. It is a product of the phloem flow rate and the concentration of Pb in the phloem. It is assumed that phloem flow will be from source to sink in accordance with the Munch hypothesis, with the flow being driven by the amount of photosynthate in these sources and sinks (Marschner, 1983:20-24), (Salisbury and Ross, 1992: 164 and 181), (Kochian, 1991: 249), and (Marschner, 1986: 87). The primary source for photosynthate, and thus phloem flow, is mature leaves, and the primary sinks the roots and ear. It is assumed that Pb will move in the same direction and at the same rate as the phloem flow of photosynthate.

Units: mg of Pb/day

$Lf_Plhm_Precip = IF(Lf_Phlm_Pb_Conc > Sol_Prdct_Phlm)$
THEN $((Lf_Phlm_Pb_Conc - Sol_Prdct_Phlm) / Lf_Phlm_Pb_Conc) * Pb_Lf_Phlm * Phlm_Precip_Rte$
ELSE $((Lf_Phlm_Pb_Conc - Sol_Prdct_Phlm) / Sol_Prdct_Phlm) * Lf_Phlm_Pb_Precip * Phlm_Precip_Rte$

DOCUMENT: This is the precipitation and or solubilization of Pb in the leaf phloem. If the solution in the leaf phloem is supersaturated, then some Pb will precipitate. If it is undersaturated, then some will solubilize. It is assumed that the amount that is precipitating or solubilizing is dependent upon the amount of Pb in precipitate or solution, the rate of precipitation, the total solubility of Pb at pH

8.0, the concentration of Pb in solution, and the concentration of free phosphate in the leaf phloem (which is assumed to be 0.0001 molar). It is also assumed that the dominant form of precipitate will be an amorphous Pb-phosphate (Malone and others, 1974: 388).

Units: mg/day

Stock

$Pb_Lf_Tissue(t) = Pb_Lf_Tissue(t - dt) + (Lf_Xylm_toTiss - Lf_TissPFlw - Precip_Lf) * dt$

INIT $Pb_Lf_Tissue = 0$

DOCUMENT: This includes Pb in the leaf symplast (excluding the phloem) and in the apoplast (excluding the xylem) that has not been precipitated (remains soluble).

Units: mg

Inflows

$Lf_Xylm_toTiss = SL_X_Flw_Rte * Lf_X_Pb_Conc$

DOCUMENT: The flow into the leaf tissue will be dependent upon the flow of Pb in from the stem. It is assumed that negligible xylem to phloem transfer is taking place in the leaf.

Units: mg/day

Outflows

$Lf_TissPFlw = Lf_TissP_Flw_Rte * Lf_Tiss_Pb_Conc$

DOCUMENT: The flow of Pb that is going out of the leaf tissue and into the leaf the phloem. It is assumed that phloem flow will be from source to sink in accordance with the Munch hypothesis, with the flow being driven by the amount of photosynthate in these sources and sinks (Marschner, 1983:20-24), (Salisbury and Ross, 1992: 164 and 181), (Kochian, 1991: 249), and (Marschner, 1986: 87). The primary source for photosynthate, and thus phloem flow, is mature leaves, and the primary sinks the roots and ear. It is assumed that Pb will move in the same direction and at the same rate as the phloem flow of photosynthate. The flow that moves from the leaf tissue to the leaf phloem is the product of the soluble Pb tissue concentration and the flow rate out of the tissue.

Units: mg of Pb/day

$Precip_Lf = IF(Lf_Tiss_Pb_Conc > Sol_Prdct) THEN(((Lf_Tiss_Pb_Conc - Sol_Prdct) / Lf_Tiss_Pb_Conc) * Pb_Lf_Tissue * Precip_Rte)$

$ELSE(((Lf_Tiss_Pb_Conc - Sol_Prdct) / Sol_Prdct) * Lf_Tissue_Precip_Pb * Precip_Rte)$

DOCUMENT: This is the precipitation and or solubilization of Pb in the leaf tissue. If the solution in the leaf tissue is supersaturated, then some Pb will precipitate. If it is undersaturated, then some will solubilize. It is assumed that the amount that is precipitating or solubilizing is dependent upon the amount of Pb in precipitate or solution, the rate of precipitation, the total solubility of Pb at pH 7, the concentration of Pb in solution, and the concentration of free phosphate in the leaf tissue (which is assumed to be 0.0001 molar). It is also assumed that the dominant form of precipitate will be an amorphous Pb-phosphate (Malone and others, 1974: 388).

Units: mg/day

Stock

$Pb_Lf_Xlm(t) = Pb_Lf_Xlm(t - dt) + (Xylm_Trans_Lf - Lf_Xylm_toTiss) * dt$

INIT $Pb_Lf_Xlm = 0$

DOCUMENT: The mass soluble Pb in the leaf xylem.

Units: mg

Inflows

$Xylm_Trans_Lf = SL_X_Flw_Rte * SX_Pb_Conc * (1 - SX_CEC_Fctr) * (1 - SXP_Trns_Frac)$

DOCUMENT: The amount of Pb that is being translocated from the stem to the leaf via the xylem. It is dependent upon the xylem flow rate and the concentration of Pb in the xylem sap. Additionally, Pb will adsorbed to the xylem before it is translocated to the leaf, and it will also transported to the phloem before being translocated to the leaf. Therefore, these two factors have a negative influence on the amount of Pb translocated to the leaf.

Units: mg of Pb/day

Outflows

$Lf_Xylm_toTiss = SL_X_Flw_Rte * Lf_X_Pb_Conc$

DOCUMENT: The flow into the leaf tissue will be dependent upon the flow of Pb in from the stem. It is assumed that negligible xylem to phloem transfer is taking place in the leaf.

Units: mg/day

Parameters

$LfStm_P_Flw_Rte = Lf_TissP_Flw_Rte$

DOCUMENT: This is the flow rate in the phloem from the leaf to the stem. It is assumed to be equal to the flow rate out of the leaf tissue to the leaf phloem.

Units: liters/day

$Lf_Phlm_Pb_Conc = Pb_Lf_Phlm / Lf_Phlm_Vol$

DOCUMENT: The concentration of Pb in the leaf phloem. It is assumed that all Pb in the phloem is soluble.

Units: mg/liter

$Lf_TissP_Flw_Rte = SL_X_Flw_Rte * Lf_Phlm_Flw_Fctr * Max_Phlm_Rte$

DOCUMENT: This describes the flow rate of the phloem out of the leaf tissue and into the phloem. Recognizing that the flow in the phloem will always be significantly slower than the xylem, it is assumed to be some fraction of the xylem flow rate, and proportional to the xylem flow rate (Marschner, 1986: 91) and (Nobel, 1991: 510 and 515). The flow rate will reach its maximum value when the leaves are mature and begin to senesce (Marschner, 1983:20-24), (Salisbury and Ross, 1992: 164 and 181), (Kochian, 1991: 249), and (Marschner, 1986: 87).

Units: liters/day

$Lf_Tiss_Pb_Conc = Pb_Lf_Tissue / Lf_Tiss_Vol$

DOCUMENT: The concentration of soluble Pb in the tissue of the leaf (symplast (excepting phloem) and apoplast (excepting xylem)).
Units: mg of Pb/liter of tissue

$Lf_X_Pb_Conc = Pb_Lf_Xlm/Lf_Xylm_Vol$

DOCUMENT: The concentration of soluble Pb in the leaf xylem.
Units: mg ofPb/liter of xylem

$Max_Phlm_Rte = .15$

DOCUMENT: This describes the maximum rate of flow in the phloem compared to the xylem. Recognizing that the flow in the phloem will always be significantly slower than the xylem, this rate is a fraction (Marschner, 1986: 91) and (Nobel, 1991: 510 and 515).
Units: unitless

$SL_X_Flw_Rte = Lf_Mss_Frac * RX_Flw_Rte * Lf_Tsp_Fctr$

DOCUMENT: The flow rate of sap from the stem xylem to the leaf xylem. It is assumed to be some fraction of the flow rate out of the root to the stem as scaled by the live mass of the leaf relative to the mass of the rest of the shoot and a stem transpiration factor since relatively large amount of transpiration takes place in the leaf in comparison to the stem and ear.
Units: liter/day

Graphs

$Lf_Phlm_Flw_Fctr = GRAPH(Lf_Live_Mass)$

(0.00, 0.204), (0.042, 0.216), (0.084, 0.272), (0.126, 0.348), (0.168, 0.46), (0.21, 0.6), (0.252, 0.768), (0.294, 0.896), (0.336, 0.96), (0.378, 0.988), (0.42, 1.00)

DOCUMENT: This factor is used to scale the phloem flow rate in comparison to the maximum phloem flow rate. It varies with the live mass of the leaves. This net phloem flow will be the greatest when the leaves are no longer growing, i.e. all the leaves are mature -- which is when the leaves reach their maximum live mass. At this point almost all of the leaves are mature, and phloem flow is the greatest out of the leaves. Therefore, when the leaf live mass reaches its maximum, the phloem flow factor reaches its maximum and the phloem flow rate is maximized. The maximum value of 0.42 kg was determined by making several model runs without any Pb in solution. It is assumed that the phloem flow will never be less than 20% of its maximum potential.
Units: unitless

$Lf_Tsp_Fctr = GRAPH(Lf_Mss_Frac)$

(0.2, 0.6), (0.26, 0.627), (0.32, 0.659), (0.38, 0.69), (0.44, 0.723), (0.5, 0.751), (0.56, 0.78), (0.62, 0.812), (0.68, 0.84), (0.74, 0.872), (0.8, 0.9)

DOCUMENT: This is a factor that is used to scale the xylem flow rate into the leaf with respect to its mass fraction and the total xylem flow from the root. It is assumed to vary with the mass fraction of the leaf. Since relatively the majority of transpiration takes place in

the leaf in comparison to the ear or stem, this factor will always be relatively high (Marschner, 1986: 99) and (Kramer and Boyer, 1995: 204 and 228).

Units: unitless

Root Sector

Stock

$Pb_RtSrf_RCA(t) = Pb_RtSrf_RCA(t - dt) + (Flw_Rt_Srf - Rt_Uptake - Prcp_Flw_RtSrf_RCA) * dt$

INIT $Pb_RtSrf_RCA = PbConc_Soil_Sltn * RFS_Vol$

DOCUMENT: This is the reservoir of Pb at the root surface and within the free space of the root cortex apoplast. Due to the cation exchange capacity of the free space and the apoplast of the epidermis, there can be a buildup of Pb in this area, thus increasing the effective concentration at uptake sites into the cells. Due to this phenomenon, a positive influence has been observed between CEC and the uptake rates of ions such as K and Ca (Marschner, 1986: 11). However, it is assumed that there will be some precipitation of Pb that takes place at the root surface and in the free space also (Malone and others, 1974: 388).

Units: mg

Inflows

$Flw_Rt_Srf = (PbConc_Soil_Sltn * Daily_Trnsptn) + ((PbConc_Soil_Sltn - (PbCnc_RtSrf_RCA / Rt_Srf_Prt_Coef)) * Rt_Srf_Prt_Rte)$

DOCUMENT: Pb will move to the root surface by mass flow and diffusion. If the concentration at the root surface is higher than that in the solution, then some Pb will diffuse away from the root at the same time that mass flow is moving Pb towards the root. If Pb concentration in the soil solution, then Pb will diffuse towards the root surface along with mass flow. The root tends to build up a concentration of cations at the surface due to the CEC of the apoplast of the external root surface and in the free space. Therefore, Pb^{2+} will have a tendency to buildup greater concentrations there that would normally begin to diffuse away from the root (Gregory, 1988: 155-156), (Mengel and Kirkby, 1987: 68-69), and (Marschner, 1986: 11) It is assumed that this process can be described by a partition coefficient. The magnitude of this coefficient is assumed to be large enough to make this more important than mass flow at most times.

Units: mg/day

Outflows

$Rt_Uptake = IF(Swtch=0)$

$THEN((Vmax * PbCnc_RtSrf_RCA) / (Km + PbCnc_RtSrf_RCA)) * Rt_Dry_Mass)$

$ELSE((Vmax * Retard_Factor * PbCnc_RtSrf_RCA) / (Km + PbCnc_RtSrf_RCA)) * Rt_Dry_Mass * Eff_Rt_Mass)$

DOCUMENT: The uptake of Pb into the symplast of the root. This is the assumed form of uptake equation for Pb from the soil solution. It is assumed to be dependent upon the Pb concentration at the root surface, the Michaelis-Menten saturable equation, and the dry mass of the roots. Dry mass is used instead of live mass because the experimental data from which Km and Vmax were computed used dry mass. Refer to the literature review for a discussion of this form of uptake.

Additionally, the IF/THEN statement is used to turn on the hypothesized VMax value instead of the experimental value.

Units: mg of Pb/day

$$\text{Prpc_Flw_RtSrf_RCA} = \text{IF}(\text{PbCnc_RtSrf_RCA} > \text{Srf_Sol_Prdct})$$

THEN(((PbCnc_RtSrf_RCA-

Srf_Sol_Prduct)/PbCnc_RtSrf_RCA)*RS_RCA_Prcp_Rte*Pb_RtSurf_RCA)

ELSE(((PbCnc_RtSrf_RCA-

Srf_Sol_Prduct)/Srf_Sol_Prduct)*RS_RCA_Prcp_Rte*Prpc_Pb_RtSrf_RCA)

DOCUMENT: This is the precipitation and or solubilization of Pb in the free space and the apoplast of the root epidermis. If the solution in the root free space and at the root surface is supersaturated, then some Pb will precipitate. If it is undersaturated, then some will solubilize. It is assumed that the amount that is precipitating or solubilizing is dependent upon the amount of Pb in precipitate or solution, the rate of precipitation, the total solubility of Pb at pH 7, the concentration of Pb in solution, and the concentration of free phosphate in the root free space (which is assumed to be 0.0001 molar). It is also assumed that the dominant form of precipitate will be an amorphous Pb-phosphate (Malone and others, 1974: 388).

Units: mg/day

Stock

$$\text{Pb_Rt_Phlm}(t) = \text{Pb_Rt_Phlm}(t - dt) + (\text{Rt_XP_Trnsfr} + \text{Phlm_Trans_Rt} - \text{Rt_PTiss_Flow} - \text{Rt_Phlm_Precip}) * dt$$

INIT Pb_Rt_Phlm = 0

DOCUMENT: The mass of Pb in the root phloem.

Units: mg of Pb

Inflows

$$\text{Rt_XP_Trnsfr} = \text{Rt_Xylm_Pb_Conc} * \text{RX_Flw_Rte} * \text{Rt_XP_Trns_Factr} * (1 - \text{RX_CEC_Fctr})$$

DOCUMENT: This is the flow of Pb that is actively transferred from the xylem to the phloem along with nutrients. It is assumed to be influenced by: the concentration of the Pb in the root xylem; the flow rate of water in the xylem, which is scaled by the xylem-phloem transfer fraction; the root xylem CEC factor which accounts for adsorption of Pb cations on the xylem cell wall. It is also assumed that the transfer from the xylem to the phloem will be greater in the stem than in the roots (Marschner, 1986: 89)

Units: mg of Pb/day

$$\text{Phlm_Trans_Rt} = \text{SP_Pb_Conc} * \text{SR_P_Flw_Rte}$$

DOCUMENT: The flow of Pb that is going out of the stem and into the root via the phloem. It is assumed that phloem flow will be from source to sink in accordance with the Munch hypothesis, with the flow being driven by the amount of photosynthate in these sources and sinks (Marschner, 1983:20-24), (Salisbury and Ross, 1992: 164 and 181), (Kochian, 1991: 249), and (Marschner, 1986: 87). The primary source for photosynthate, and thus phloem flow, is mature leaves, and the primary sinks are the roots and ear. It is assumed that Pb will move in the same direction and at the same rate as the phloem flow of photosynthate. Therefore, the flow that moves from the leaves to the

root through the stem is the product of the Pb concentration and the flow rate to the root.

Units: mg of Pb/day

Outflows

$Rt_PTiss_Flow = Rt_Phlm_Pb_Conc * SR_P_Flw_Rte$

DOCUMENT: The flow of Pb out of the root phloem and into the root tissue. The flow rate out of the phloem into the tissue is assumed to be the same as the flow rate into the root phloem from the stem phloem. It is assumed that phloem flow will be from source to sink in accordance with the Munch hypothesis, with the flow being driven by the amount of photosynthate in these sources and sinks (Marschner, 1983:20-24), (Salisbury and Ross, 1992: 164 and 181), (Kochian, 1991: 249), and (Marschner, 1986: 87). The primary source for photosynthate, and thus phloem flow, is mature leaves, and the primary sinks are the roots and ear. It is assumed that Pb will move in the same direction and at the same rate as the phloem flow of photosynthate.

Units: mg of Pb/day

$Rt_Phlm_Precip = IF(Rt_Phlm_Pb_Conc > Sol_Prdct_Phlm)$

THEN(($Rt_Phlm_Pb_Conc - Sol_Prdct_Phlm$)/ $Rt_Phlm_Pb_Conc$)* $Pb_Rt_Phlm * Phlm_Precip_Rte$)

ELSE(($Rt_Phlm_Pb_Conc - Sol_Prdct_Phlm$)/ Sol_Prdct_Phlm)* $Rt_Phlm_Pb_Precip * Phlm_Precip_Rte$)

DOCUMENT: This is the precipitation and or solubilization of Pb in the root phloem. If the solution in the root phloem is supersaturated, then some Pb will precipitate. If it is undersaturated, then some will solubilize. It is assumed that the amount that is precipitating or solubilizing is dependent upon the amount of Pb in precipitate or solution, the rate of precipitation, the total solubility of Pb at pH 8.0, the concentration of Pb in solution, and the concentration of free phosphate in the root phloem (which is assumed to be 0.0001 molar). It is also assumed that the dominant form of precipitate will be an amorphous Pb-phosphate (Malone and others, 1974: 388).

Units: mg/day

Stock

$Pb_Rt_Tissue(t) = Pb_Rt_Tissue(t - dt) + (Rt_Uptake + Rt_PTiss_Flow - Pb_RTiss_to_Xy - Rt_Precip) * dt$

INIT $Pb_Rt_Tissue = 0$

DOCUMENT: This includes Pb in the root symplast (excluding the phloem) and in the apoplast (excluding the xylem) inside the stele that has not been precipitated (remains soluble).

Units: mg

Inflows

$Rt_Uptake = IF(Swch=0)$

THEN(($(Vmax * PbCnc_RtSrf_RCA) / (Km + PbCnc_RtSrf_RCA)$)* Rt_Dry_Mass)

ELSE(($(Vmax * Retard_Factor * PbCnc_RtSrf_RCA) / (Km + PbCnc_RtSrf_RCA)$)* $Rt_Dry_Mass * Eff_Rt_Mass$)

DOCUMENT: The uptake of Pb into the symplast of the root. This is the assumed form of uptake equation for Pb from the soil solution. It is assumed to be dependent upon the Pb concentration at the root surface, the Michaelis-Menten saturable equation, and the dry mass of the roots. Dry mass is used instead of live mass because the experimental data

from which Km and Vmax were computed used dry mass. Refer to the literature review for a discussion of this form of uptake. Additionally, the IF/THEN statement is used to turn on the hypothesized VMax value instead of the experimental value.
Units: mg of Pb/day

$Rt_PTiss_Flow = Rt_Phlm_Pb_Conc * SR_P_Flw_Rte$

DOCUMENT: The flow of Pb out of the root phloem and into the root tissue. The flow rate out of the phloem into the tissue is assumed to be the same as the flow rate into the root phloem from the stem phloem. It is assumed that phloem flow will be from source to sink in accordance with the Munch hypothesis, with the flow being driven by the amount of photosynthate in these sources and sinks (Marschner, 1983:20-24), (Salisbury and Ross, 1992: 164 and 181), (Kochian, 1991: 249), and (Marschner, 1986: 87). The primary source for photosynthate, and thus phloem flow, is mature leaves, and the primary sinks are the roots and ear. It is assumed that Pb will move in the same direction and at the same rate as the phloem flow of photosynthate.

Units: mg of Pb/day

Outflows

$Pb_RTiss_to_Xy = Rt_Tiss_Pb_Conc * RX_Flw_Rte$

DOCUMENT: This flow represents the net movement of Pb through the root tissue (symplast and apoplast inside the stele, excepting xylem and phloem) to the root xylem. The assumption here is that the Pb must enter the symplast of the root to get past the endodermis before it can reach the root xylem (Kochian, 1991: 242) and many others. It is also assumed that the rate of flow out of the symplast and into the xylem is equal to the flow rate in the xylem from root to stem. This is a net flow, because even in the root there will be some flow out of the xylem and into the root symplast. (Marschner, 1986: 94)

Units: mg/day

$Rt_Precip = IF(Rt_Tiss_Pb_Conc > Sol_Prdct) THEN((Rt_Tiss_Pb_Conc - Sol_Prdct) / Rt_Tiss_Pb_Conc) * Pb_Rt_Tissue * Precip_Rte$
 $ELSE((Rt_Tiss_Pb_Conc - Sol_Prdct) / Sol_Prdct) * Rt_Tissue_Precip_Pb * Precip_Rte$

DOCUMENT: This is the precipitation and or solubilization of Pb in the root symplast, and apoplast inside the stele. If the solution in the root tissue is supersaturated, then some Pb will precipitate. If it is undersaturated, then some will solubilize. It is assumed that the amount that is precipitating or solubilizing is dependent upon the amount of Pb in precipitate or solution, the rate of precipitation, the total solubility of Pb at pH 7, the concentration of Pb in solution, and the concentration of free phosphate in tissue (which is assumed to be 0.0001 molar). It is also assumed that the dominant form of precipitate will be an amorphous Pb-phosphate (Malone and others, 1974: 388).

Units: mg/day

Stock

$Pb_Rt_Xylm(t) = Pb_Rt_Xylm(t - dt) + (Pb_RTiss_to_Xy - Rt_Xy_Trns_Stm - Rt_XP_Trnsfr - Rt_Xylm_Adsorb_CW - Rt_Xylm_Precip) * dt$

INIT $Pb_Rt_Xylm = 0$

DOCUMENT: The mass soluble Pb in the root xylem.

Units: mg

Inflows

$$\text{Pb_RTiss_to_Xy} = \text{Rt_Tiss_Pb_Conc} * \text{RX_Flw_Rte}$$

DOCUMENT: This flow represents the net movement of Pb through the root tissue (symplast and apoplast inside the stele, excepting xylem and phloem) to the root xylem. The assumption here is that the Pb must enter the symplast of the root to get past the endodermis before it can reach the root xylem (Kochian, 1991: 242) and many others. It is also assumed that the rate of flow out of the symplast and into the xylem is equal to the flow rate in the xylem from root to stem. This is a net flow, because even in the root there will be some flow out of the xylem and into the root symplast. (Marschner, 1986: 94)

Units: mg/day

Outflows

$$\text{Rt_Xy_Trns_Stm} = \text{RX_Flw_Rte} * \text{Rt_Xylm_Pb_Conc} * (1 - \text{RX_CEC_Fctr}) * (1 - \text{Rt_XP_Trns_Factr})$$

DOCUMENT: The amount of Pb that is being translocated from the root to the stem via the xylem. It is dependent upon the transpiration stream and the concentration of Pb in the xylem sap. Additionally, Pb will adsorbed to the xylem before it is translocated to the stem, and it will also transported to the phloem before being translocated to the stem. Therefore, these two factors have a negative influence on the amount of Pb translocated to the stem.

Units: mg of Pb/day

$$\text{Rt_XP_Trnsfr} = \text{Rt_Xylm_Pb_Conc} * \text{RX_Flw_Rte} * \text{Rt_XP_Trns_Factr} * (1 - \text{RX_CEC_Fctr})$$

DOCUMENT: This is the flow of Pb that is actively transferred from the xylem to the phloem along with nutrients. It is assumed to be influenced by: the concentration of the Pb in the root xylem; the flow rate of water in the xylem, which is scaled by the xylem-phloem transfer fraction; the root xylem CEC factor which accounts for adsorption of Pb cations on the xylem cell wall. It is also assumed that the transfer from the xylem to the phloem will be greater in the stem than in the roots (Marschner, 1986: 89)

Units: mg of Pb/day

$$\text{Rt_Xylm_Adsorb_CW} = \text{Rt_Xylm_Pb_Conc} * \text{RX_Flw_Rte} * \text{RX_CEC_Fctr}$$

DOCUMENT: This is the Pb that is being adsorbed to the xylem cell wall. It is a function of the concentration of Pb in the xylem, the flow rate of the xylem, and the rate of net adsorption of Pb onto the xylem cell wall. It is assumed here that the xylem cell wall acts essentially as a cation exchanger, and other cations such as Ca²⁺ are also present in the xylem and play much more significant role in "filling" the xylem cell walls with cations to achieve breakthrough (Marschner, 1986: 73). It is also assumed that the majority of Pb in the xylem will be in the form of Pb²⁺.

Units: mg/day

$$\text{Rt_Xylm_Precip} = \text{IF}(\text{Rt_Xylm_Pb_Conc} > \text{Sol_Prdct_Xylm})$$

THEN(((Rt_Xylm_Pb_Conc - Sol_Prdct_Xylm) / Rt_Xylm_Pb_Conc) * Pb_Rt_Xylm * Xylm_Prcp_Rte)

ELSE(((Rt_Xylm_Pb_Conc-
Sol_Prdct_Xylm)/Sol_Prdct_Xylm)*Rt_Xylm_Pb_Precip*Xylm_Prcp_Rte)
DOCUMENT: This is the precipitation and or solubilization of Pb in the
root xylem. If the solution in the root xylem is supersaturated, then
some Pb will precipitate. If it is undersaturated, then some will
solubilize. It is assumed that the amount that is precipitating or
solubilizing is dependent upon the amount of Pb in precipitate or
solution, the rate of precipitation, the total solubility of Pb at pH
5.5, the concentration of Pb in solution, and the concentration of free
phosphate in the root xylem (which is assumed to be 0.0001 molar). It
is also assumed that th dominant form of precipitate will be an
amorphous Pb-phosphate (Malone and others, 1974: 388).
Units: mg/day

Stock

Prpc_Pb_RtSrf_RCA(t) = Prpc_Pb_RtSrf_RCA(t - dt) + (Prpc_Flw_RtSrf_RCA)
* dt

INIT Prpc_Pb_RtSrf_RCA = 0

DOCUMENT: This is the precipitate at the root surface and in the root
free space (Malone and others, 1974: 388). It is assumed that some
precipitate will form in this area.

Units: mg

Inflows

Prpc_Flw_RtSrf_RCA = IF(PbCnc_RtSrf_RCA>Srf_Sol_Prdct)

THEN(((PbCnc_RtSrf_RCA-

Srf_Sol_Prdct)/PbCnc_RtSrf_RCA)*RS_RCA_Prcp_Rte*Pb_RtSrf_RCA)

ELSE(((PbCnc_RtSrf_RCA-

Srf_Sol_Prdct)/Srf_Sol_Prdct)*RS_RCA_Prcp_Rte*Prpc_Pb_RtSrf_RCA)

DOCUMENT: This is the precipitation and or solubilization of Pb in the
free space and the apoplast of the root epidermis. If the solution in
the root free space and at the root surface is supersaturated, then
some Pb will precipitate. If it is undersaturated, then some will
solubilize. It is assumed that the amount that is precipitating or
solubilizing is dependent upon the amount of Pb in precipitate or
solution, the rate of precipitation, the total solubility of Pb at pH
7, the concentration of Pb in solution, and the concentration of free
phosphate in the root free space (which is assumed to be 0.0001 molar).
It is also assumed that the dominant form of precipitate will be an
amorphous Pb-phosphate (Malone and others, 1974: 388).

Units: mg/day

Stock

Rt_Phlm_Pb_Precip(t) = Rt_Phlm_Pb_Precip(t - dt) + (Rt_Phlm_Precip) *
dt

INIT Rt_Phlm_Pb_Precip = 0

DOCUMENT: This is the amount of Pb that is precipitated in the phloem
of the root.

Units: mg of Pb

Inflows

Rt_Phlm_Precip = IF(Rt_Phlm_Pb_Conc>Sol_Prdct_Phlm)

THEN(((Rt_Phlm_Pb_Conc-

Sol_Prdct_Phlm)/Rt_Phlm_Pb_Conc)*Pb_Rt_Phlm*Phlm_Precip_Rte)

ELSE(((Rt_Phlm_Pb_Conc-
Sol_Prdct_Phlm)/Sol_Prdct_Phlm)*Rt_Phlm_Pb_Precip*Phlm_Precip_Rte)
DOCUMENT: This is the precipitation and or solubilization of Pb in the
root phloem. If the solution in the root phloem is supersaturated,
then some Pb will precipitate. If it is undersaturated, then some will
solubilize. It is assumed that the amount that is precipitating or
solubilizing is dependent upon the amount of Pb in precipitate or
solution, the rate of precipitation, the total solubility of Pb at pH
8.0, the concentration of Pb in solution, and the concentration of free
phosphate in the root phloem (which is assumed to be 0.0001 molar). It
is also assumed that the dominant form of precipitate will be an
amorphous Pb-phosphate (Malone and others, 1974: 388).
Units: mg/day

Stock

Rt_Tissue_Precip_Pb(t) = Rt_Tissue_Precip_Pb(t - dt) + (Rt_Precip) * dt
INIT Rt_Tissue_Precip_Pb = 0

DOCUMENT: The total amount of Pb that has been precipitated tissue in
the root tissue (symplast (excepting phloem) or apoplast inside the
stele (excepting xylem)). If it precipitates in the symplast, it
assumed that it will be moved outside of the symplast and into the
apoplast, being deposited in the cell wall (Malone and others, 1974:
391).

Units: mg of Pb

Inflows

Rt_Precip = IF(Rt_Tiss_Pb_Conc>Sol_Prdct) THEN(((Rt_Tiss_Pb_Conc-
Sol_Prdct)/Rt_Tiss_Pb_Conc)*Pb_Rt_Tissue*Precip_Rte)
ELSE(((Rt_Tiss_Pb_Conc-
Sol_Prdct)/Sol_Prdct)*Rt_Tissue_Precip_Pb*Precip_Rte)

DOCUMENT: This is the precipitation and or solubilization of Pb in the
root symplast, and apoplast inside the stele. If the solution in the
root tissue is supersaturated, then some Pb will precipitate. If it is
undersaturated, then some will solubilize. It is assumed that the
amount that is precipitating or solubilizing is dependent upon the
amount of Pb in precipitate or solution, the rate of precipitation, the
total solubility of Pb at pH 7, the concentration of Pb in solution,
and the concentration of free phosphate in tissue (which is assumed to
be 0.0001 molar). It is also assumed that the dominant form of
precipitate will be an amorphous Pb-phosphate (Malone and others, 1974:
388).

Units: mg/day

Stock

Rt_Xylm_CW_Pb(t) = Rt_Xylm_CW_Pb(t - dt) + (Rt_Xylm_Adsorb_CW) * dt
INIT Rt_Xylm_CW_Pb = 0

DOCUMENT: The mass of Pb that is adsorbed to the xylem cell wall.

Units: mg of Pb

Inflows

Rt_Xylm_Adsorb_CW = Rt_Xylm_Pb_Conc*RX_Flw_Rte*RX_CEC_Fctr

DOCUMENT: This is the Pb that is being adsorbed to the xylem cell
wall. It is a function of the concentration of Pb in the xylem, the
flow rate of the xylem, and the rate of net adsorption of Pb onto the
xylem cell wall. It is assumed here that the xylem cell wall acts

essentially as a cation exchanger, and other cations such as Ca^{2+} are also present in the xylem and play much more significant role in "filling" the xylem cell walls with cations to achieve breakthrough (Marschner, 1986: 73). It is also assumed that the majority of Pb in the xylem will be in the form of Pb^{2+} .

Units: mg/day

Stock

$\text{Rt_Xylm_Pb_Precip}(t) = \text{Rt_Xylm_Pb_Precip}(t - dt) + (\text{Rt_Xylm_Precip}) * dt$

INIT $\text{Rt_Xylm_Pb_Precip} = 0$

DOCUMENT: This is the amount of Pb that is precipitated in the xylem of the root.

Units: mg of Pb

Inflows

$\text{Rt_Xylm_Precip} = \text{IF}(\text{Rt_Xylm_Pb_Conc} > \text{Sol_Prdct_Xylm})$
THEN $((\text{Rt_Xylm_Pb_Conc} - \text{Sol_Prdct_Xylm}) / \text{Rt_Xylm_Pb_Conc}) * \text{Pb_Rt_Xylm} * \text{Xylm_Prpc_Rte}$
ELSE $((\text{Rt_Xylm_Pb_Conc} - \text{Sol_Prdct_Xylm}) / \text{Sol_Prdct_Xylm}) * \text{Rt_Xylm_Pb_Precip} * \text{Xylm_Prpc_Rte}$

DOCUMENT: This is the precipitation and or solubilization of Pb in the root xylem. If the solution in the root xylem is supersaturated, then some Pb will precipitate. If it is undersaturated, then some will solubilize. It is assumed that the amount that is precipitating or solubilizing is dependent upon the amount of Pb in precipitate or solution, the rate of precipitation, the total solubility of Pb at pH 5.5, the concentration of Pb in solution, and the concentration of free phosphate in the root xylem (which is assumed to be 0.0001 molar). It is also assumed that the dominant form of precipitate will be an amorphous Pb-phosphate (Malone and others, 1974: 388).

Units: mg/day

Parameters

$\text{CEC_Goal} = 200$

DOCUMENT: This goal is the level of Pb where the xylem is essentially filled with cations, and therefore the flow is essentially unrestricted because Pb ions are desorbing into the transpiration stream as fast as they are adsorbing onto the xylem cell wall. (Refer to Marschner, 1986: 73)

Units: mg of Pb/kg of xylem cell wall dry mass

$\text{Km} = 8.3$

DOCUMENT: This value is the half-saturation constant for the uptake equation that is compared to a Michaelis-Menten enzyme relationship. It is the Pb solution concentration when the uptake of Pb is half of the maximum (mg/liter). This value has been derived from experimental data from (Huang and Cunningham, 1996: 78). Refer to appendix for the derivation of this value from the experimental data.

Units: mg/liter

$\text{PbCnc_RtSrf_RCA} = \text{IF}(\text{RFS_Vol} = 0) \text{ THEN}(0) \text{ ELSE}(\text{Pb_RtSrf_RCA} / \text{RFS_Vol})$

DOCUMENT: This is the concentration of Pb at the root surface and within the free space of the root cortex apoplast. Due to the cation exchange capacity of the free space and the apoplast of the epidermis,

there can be a buildup of Pb in this area, thus increasing the effective concentration at uptake sites into the cells. Due to this phenomenon, a positive influence has been observed between CEC and the uptake rates of ions such as K and Ca (Marschner, 1986: 11). However, it is assumed that there will be some precipitation of Pb that takes place at the root surface and in the free space also (Malone and others, 1974: 388).

Units: mg

$PbConc_Soil_Sltn = 0 + STEP(4,1)$

DOCUMENT: This value is an environmental parameter. It is the amount of Pb in the soil solution.

Units: (mg/liter) converting to molar concentration, divide by 207 g Pb/mole*(1000mg/g) , i.e. divide by 27,000

$Phlm_Precip_Rte = Xylm_Prpc_Rte*2$

DOCUMENT: The rate of precipitation in the phloem throughout the plant. The assumptions here are that: precipitation rates will be the same in phloem throughout the plant; precipitation rates in the phloem will be proportional to those in the rest of the plant, but they will be lower due to the faster rate of movement of Pb in the phloem compared to other tissues in the plant. However, they will be higher than in the xylem because movement in the phloem is slower than in the xylem.

Units: per day

$Precip_Rte = 5$

DOCUMENT: The rate at which the Pb/Pb-phosphate precipitation/solubilization reaction occurs. It is assumed that this reaction will occur at the same rate throughout the entire plant except for the xylem. If this rate is 1, then it means that the reaction would go to completion once per day, if it is 7, it means that the reaction would occur rapidly enough for the reaction to come to completion 7 times per day.

Units: per day

$RFS_Vol = Rt_Fr_Spce_Frac*Rt_Vol$

DOCUMENT: This is the volume that the root free space and the root epidermis together comprise of the total root volume. It is dependent upon the fraction of the total root volume that is comprised of the free space, and the total root volume.

Units: liters

$RS_RCA_DM_PbCnc = Prpc_Pb_RtSrf_RCA/RtSrf_RCA_Dry_Mass$

DOCUMENT: This is the dry mass concentration of Pb in the cell walls of the root surface and the RCA.

Units: mg of Pb/kg of dry mass

$RS_RCA_Prpc_Rte = Precip_Rte*RS_RCA_Prpc_Fctr$

DOCUMENT: This is the precipitation rate in the root surface and RCA. It is assumed here that precipitate will form quickly initially, but after the initial buildup, there will be very little precipitation here. The precipitation factor is therefore used to scale the precipitation rate as compared to the precipitation in the rest of the plant.

Units: per day

$Rt_Fr_Spce_Frac = .08$

DOCUMENT: The fraction of total root volume that is comprised of the free space. In roots this is between 7% and 10% of the root volume (Lindstrom and others, 1991: 131) and (Marschner, 1986: 9). It is assumed here to be 8% of the total root volume.

Units: unitless

$Rt_Phlm_Pb_Conc = Pb_Rt_Phlm/Rt_Phlm_Vol$

DOCUMENT: The concentration of Pb in the root phloem. It is assumed that all Pb in the phloem is soluble.

Units: unitless

$Rt_Srf_Prt_Coef = 15$

DOCUMENT: The root tends to build up a concentration of cations at the surface due to the CEC of the apoplast of the external root surface and in the free space. Therefore, Pb^{2+} will have a tendency to buildup greater concentrations there that would normally begin to diffuse away from the root (Gregory, 1988: 155-156), (Mengel and Kirkby, 1987: 68-69), and (Marschner, 1986: 11). It is assumed that this process can be described by a partition coefficient. The magnitude of this coefficient is assumed to be large enough to make this more important than mass flow at most times.

Units: unitless

$Rt_Tiss_Pb_Conc = Pb_Rt_Tissue/Rt_Tiss_Vol$

DOCUMENT: The concentration of soluble Pb in the tissue of the root (symplast (excepting phloem) and apoplast inside the stele (excepting xylem)).

Units: mg of Pb/liter of tissue

$Rt_XP_Trns_Factr = .005$

DOCUMENT: This is a factor that describes what portion of the xylem water flow is going to the phloem. It is assumed that some Pb will be actively transported to the phloem from the xylem in the transfer cells along with this flow of water, similar to what happens with nutrients (Marschner, 1986: 89). However, it is also assumed that the fraction that is transferred to the phloem will be a small fraction of the total xylem flow.

Units: unitless

$Rt_Xylm_Pb_Conc = Pb_Rt_Xylm/Rt_Xylm_Vol$

DOCUMENT: The concentration of soluble Pb in the root xylem.

Units: mg of Pb/liter of xylem

$Rt_Xy_CW_Mass = Rt_Dry_Mass * Rt_Xylm_Frac * Xylm_CW_Frctn$

DOCUMENT: This is the mass of the xylem cell wall of the root.

Units: kg

$RX_CW_Pb_Cnc = Rt_Xylm_CW_Pb/Rt_Xy_CW_Mass$

DOCUMENT: This is the Pb that is adsorbed to the xylem cell wall per unit of dry mass of xylem cell wall.

Units: mg of Pb/kg cell wall dry mass

$RX_Flw_Rte = Daily_Trnsptn$

DOCUMENT: This is the rate at which water is flowing out of the root xylem to the stem xylem. It is assumed that the rate at which water is flowing through the root xylem to the shoots is equal to the amount of water that is being transpired by the plant (Kramer and Boyer, 1995: 255) and (Westgate and Boyer, 1983: 882).

Units: liters/day

$Sol_Prdct = .02$

DOCUMENT: This is the total solubility of Pb species throughout the plant in the tissue. It is assumed here that the amount of Pb that will precipitate is influenced by the total solubility of Pb-phosphate species in aqueous solution. Assuming that the total phosphate that is available to complex with Pb is on the order of 0.0001 molar (Marschner, 1986: 5), then the total solubility of Pb-phosphates will be approximately 0.02 mg/liter. This also assumes a cellular pH of 7. Refer to the MathCad worksheet in the appendix.

Units: mg/liter

$Sol_Prdct_Phlm = .01$

DOCUMENT: This is the total solubility of Pb species throughout the plant in the xylem. It is assumed here that the amount of Pb that will precipitate is influenced by the total solubility of Pb-phosphate species in aqueous solution. Assuming that the total phosphate that is available to complex with Pb is on the order of 0.0001 molar (Marschner, 1986: 5), then the total solubility of Pb-phosphates will be approximately 0.01 mg/liter. This also assumes a phloem pH of 8.0 (Marschner, 1986: 127). Refer to the MathCad worksheet in the appendix.

Units: mg/liter

$Sol_Prdct_Xylm = .38$

DOCUMENT: This is the total solubility of Pb species throughout the plant in the xylem. It is assumed here that the amount of Pb that will precipitate is influenced by the total solubility of Pb-phosphate species in aqueous solution. Assuming that the total phosphate that is available to complex with Pb is on the order of 0.0001 molar (Marschner, 1986: 5), then the total solubility of Pb-phosphates will be approximately 0.38 mg/liter. This also assumes a xylem pH of 5.5 (Marschner, 1986: 73). Refer to the MathCad worksheet in the appendix.

Units: mg/liter

$Srf_Sol_Prdct = .015$

DOCUMENT: This is the total solubility of Pb species at the root surface. It is assumed here that the amount of Pb that will precipitate is influenced by the total solubility of Pb-phosphate species in aqueous solution. Assuming that the total phosphate that is available to complex with Pb is on the order of 0.001 molar, then the total solubility of Pb-phosphates will be approximately 0.02 mg/liter. This also assumes a pH of 6. Refer to the MathCad worksheet in the appendix.

Units: mg/liter

$SR_P_Flw_Rte = LfStm_P_Flw_Rte * Er_P_Flw_Frctn$

DOCUMENT: The rate at which the phloem is flowing from the stem to the root. It is assumed to be a product of the flow going out of the leaf into the stem and the fraction of the flow that goes to the root vice the ear. Before the ear starts to grow, all of the phloem flow will go to the root. As the ear begins to grow, much less phloem flow will go to the root, but there will always be some small fraction going to the root, even when the ear is growing rapidly.

Units: liters/day

Swrch = 1

DOCUMENT: This is simply a switch that is used to turn the hypothesized mechanism (blockage or killing of channels in the roots by Pb) on or off. The switch is off if it equals zero, and it is on if it equals one.

Units: unitless

Vmax = 184

DOCUMENT: The maximum uptake rate of Pb from solution. The starting value has been derived from experimental data from (Huang and Cunningham, 1996: 78). Refer to appendix D for the derivation of this value from the experimental data.

Units: mg of Pb per g of dry root mass per day

Xylm_CW_Frctn = .1

DOCUMENT: Since the mass fraction of the xylem cell wall is assumed to be less than the volume fraction for any given plant component, this factor is multiplied by the volume fraction to determine the portion of the dry mass for the root, ear, stem or leaf that is comprised of xylem cell walls. It is assumed that this fraction is constant throughout the plant.

Units: unitless

Xylm_Prcp_Fctr = 3

DOCUMENT: This is a factor that is used to scale the precipitation rate in the xylem. Since Pb will be moving much faster in the xylem than it will be in other parts of the plant, it is assumed that the Pb will not be able to precipitate as readily in the xylem. Therefore, the precipitation rate is scaled to be proportional, yet less, in the xylem than in other parts of the plant.

$Xylm_Prcp_Rte = Precip_Rte / Xylm_Prcp_Fctr$

DOCUMENT: The rate of precipitation in the xylem throughout the plant. The assumptions here are that: precipitation rates will be the same in xylem throughout the plant; precipitation rates in the xylem will be proportional to those in the rest of the plant, but they will be lower due to the faster rate of movement of Pb in the xylem compared to other tissues in the plant.

Units: per day

Graphs

$Eff_Rt_Mass = GRAPH(TIME)$

(0.00, 1.00), (11.4, 0.925), (22.7, 0.835), (34.1, 0.735), (45.5, 0.63), (56.8, 0.515), (68.2, 0.39), (79.5, 0.26), (90.9, 0.15), (102, 0.075), (114, 0.03), (125, 0.00)

DOCUMENT: This is a hypothesized mechanism to account for the fact that a plant only uses a fraction of its total root capacity to uptake water and nutrients (Mengel and Kirkby, 1987: 95) and (Robinson, 1991: 115) Furthermore, as a plant gets older the amount per unit length of root that a plant must uptake to sustain its shoots decreases substantially (Mengel and Kirkby, 1987: 95). At the same time, as the root begins to age, its capacity to uptake water and nutrients decreases per unit of length (Robinson, 1987: 112). Therefore, this number can be multiplied by the root mass to get the effective root mass.

Unit: unitless

RS_RCA_Prcp_Fctr = GRAPH(RS_RCA_DM_PbCnc)
(0.00, 1.00), (150, 0.81), (300, 0.52), (450, 0.181), (600, 0.0559),
(750, 0.016), (900, 0.001), (1050, 0.001), (1200, 0.001), (1350,
0.001), (1500, 0.001)

DOCUMENT: This is a factor that will be used in to determine the precipitation rate in the root surface and RCA. This is based upon the understanding that root precipitate develops quickly on the root initially, but then after the initial rapid precipitation, very little additional Pb precipitate forms (Malone and others, 1974 388).

Units: unitless

Rt_Srf_Prt_Rte = GRAPH(TIME)
(0.00, 0.001), (1.82, 0.001), (3.64, 0.02), (5.45, 0.05), (7.27,
0.105), (9.09, 0.2), (10.9, 0.435), (12.7, 0.685), (14.5, 0.825),
(16.4, 0.915), (18.2, 0.965), (20.0, 1.00)

DOCUMENT: The root tends to build up a concentration of cations at the surface due to the CEC of the apoplast of the external root surface and in the free space. Therefore, Pb²⁺ will have a tendency to buildup greater concentrations there that would normally begin to diffuse away from the root. (Gregory: 155-156), (Mengel and Kirkby: 68-69), and (Marschner: 11). It is assumed that this process can be described by a partition coefficient. In addition to the partition coefficient, there is a rate at which the partitioning will occur. The rate at which this partitioning occurs is uncertain, but would likely vary somewhere between 0.1 and 1.

Units: liters/day

RX_CEC_Fctr = GRAPH((CEC_Goal-RX_CW_Pb_Cnc)/CEC_Goal)
(0.00, 0.00), (0.1, 0.24), (0.2, 0.4), (0.3, 0.544), (0.4, 0.632),
(0.5, 0.696), (0.6, 0.728), (0.7, 0.756), (0.8, 0.78), (0.9, 0.792),
(1, 0.8)

DOCUMENT: This is a factor that is used to describe what fraction of the Pb that is flowing through the xylem will be adsorbed onto the cell wall. This factor is assumed to be influenced by the concentration of Pb in the xylem cell wall (mass/mass dry weight), and some CEC goal (Pb conc mass/dry mass). As Pb first starts moving up in the xylem, much of it is adsorbed onto the cell walls, and thus the CEC factor is high because more Pb is being adsorbed than be desorbed. Once the cell wall is "filled" with Pb, i.e. Pb concentration in the xylem cell wall approaches the CEC goal, the net adsorption will be at or near zero, because Pb is being desorbed from the xylem as fast as it is being adsorbed. The CEC factor has a maximum value of .8. This is because

it is assumed that some of the Pb will always be in complexed form and thus not adsorb to the xylem wall like Pb cations will.
Units: unitless

Stem Sector

Stock

$Pb_Stm_Phlm(t) = Pb_Stm_Phlm(t - dt) + (TrnsStmXP + P_Trans_LfStm - Phlm_Trans_StmEar - Phlm_Trans_Rt - Stm_Phlm_Precip) * dt$
INIT Pb_Stm_Phlm = 0

DOCUMENT: The mass of Pb that in the stem phloem. It is assumed here that there is no net flow of phloem into or out of the stem tissue (Marschner, 1983:20-24), (Salisbury and Ross, 1992: 164 and 181), (Kochian, 1991: 249), and (Marschner, 1986: 87). In other words, the stem produces enough photosynthate to meet its needs, but not enough to export to the root or ear. From the stem, the phloem flow will go either to the roots or the ear. When the ear is young, almost all of the flow goes to the root, but as the ear develops, almost all of the flow goes to the ear.

Units: mg of Pb

Inflows

$TrnsStmXP = RX_Flw_Rte * SXP_Trns_Frac * SX_Pb_Conc * (1 - SX_CEC_Fctr)$
DOCUMENT: This is the flow of Pb that is actively transferred from the xylem to the phloem along with nutrients. It is assumed to be influenced by: the concentration of the Pb in the stem xylem; the flow rate of water in the xylem, which is scaled by the xylem-phloem transfer fraction; the stem xylem CEC factor which accounts for adsorption of Pb cations on the xylem cell wall. It is also assumed that the transfer from the xylem to the phloem will be greater in the stem than in the roots (Marschner, 1986: 89)
Units: mg of Pb/day

P_Trans_LfStm (IN SECTOR: Leaf)

Outflows

$Phlm_Trans_StmEar = IF(TIME < 40) THEN(0)$
 $ELSE(SE_Phlm_Flw_Rte * SP_Pb_Conc)$
DOCUMENT: The flow of Pb that is going out of the stem and into the ear via the phloem. It is assumed that phloem flow will be from source to sink in accordance with the Munch hypothesis, with the flow being driven by the amount of photosynthate in these sources and sinks (Marschner, 1983:20-24), (Salisbury and Ross, 1992: 164 and 181), (Kochian, 1991: 249), and (Marschner, 1986: 87). The primary source for photosynthate, and thus phloem flow, is mature leaves, and the primary sinks the roots and ear. It is assumed that Pb will move in the same direction and at the same rate as the phloem flow of

photosynthate. Therefore, the flow that moves from the leaves to the ear through the stem is the product of the Pb concentration and the flow rate to the ear. However, the ear mass is essentially zero for the first 40 days, so during this time frame there is no flow to the ear.

Units: mg of Pb/day

Phlm_Trans_Rt (IN SECTOR: Root)

Stm_Phlm_Precip = IF(SP_Pb_Conc>Sol_Prdct_Phlm) THEN(((SP_Pb_Conc-Sol_Prdct_Phlm)/SP_Pb_Conc)*Pb_Stm_Phlm*Phlm_Precip_Rte)

ELSE(((SP_Pb_Conc-Sol_Prdct_Phlm)/Sol_Prdct_Phlm)*Stm_Phlm_Pb_Precip*Phlm_Precip_Rte)
DOCUMENT: This is the precipitation and or solubilization of Pb in the stem phloem. If the solution in the stem phloem is supersaturated, then some Pb will precipitate. If it is undersaturated, then some will solubilize. It is assumed that the amount that is precipitating or solubilizing is dependent upon the amount of Pb in precipitate or solution, the rate of precipitation, the total solubility of Pb at pH 8.0, the concentration of Pb in solution, and the concentration of free phosphate in the stem phloem (which is assumed to be 0.0001 molar). It is also assumed that the dominant form of precipitate will be an amorphous Pb-phosphate (Malone and others, 1974: 388).

Units: mg/day

Stock

Pb_Stm_Tissue(t) = Pb_Stm_Tissue(t - dt) + (Stm_Xy_to_Tissue - Stm_Tiss_Precip - S_Diff_frm_Tiss) * dt

INIT Pb_Stm_Tissue = 0

DOCUMENT: This includes Pb in the stem symplast (excluding the phloem) and in the apoplast (excluding the xylem) that has not been precipitated (remains soluble).

Units: mg

Inflows

Stm_Xy_to_Tissue = (1-SX_CEC_Fctr)*(1-SXP_Trns_Frac)*STiss_X_Flw_Rte*SX_Pb_Conc

DOCUMENT: The amount of Pb that is being translocated from the stem xylem to the stem tissue. It is dependent upon the flow rate from the xylem to the tissue and the concentration of Pb in the xylem sap. Additionally, Pb will adsorbed to the xylem in the stem before it is translocated to the tissue, and it will also transported to the phloem before being translocated to the tissue. Therefore, these two factors have a negative influence on the amount of Pb translocated to the tissue.

Units: mg of Pb/day

Outflows

Stm_Tiss_Precip = IF(STiss_Pb_Conc>Sol_Prdct) THEN(((STiss_Pb_Conc-Sol_Prdct)/STiss_Pb_Conc)*Pb_Stm_Tissue*Precip_Rte)

ELSE(((STiss_Pb_Conc-Sol_Prdct)/Sol_Prdct)*Stm_Tissue_Precip_Pb*Precip_Rte)

DOCUMENT: This is the precipitation and or solubilization of Pb in the stem tissue. If the solution in the stem tissue is supersaturated, then some Pb will precipitate. If it is undersaturated, then some will

solubilize. It is assumed that the amount that is precipitating or solubilizing is dependent upon the amount of Pb in precipitate or solution, the rate of precipitation, the total solubility of Pb at pH 5.5, the concentration of Pb in solution, and the concentration of free phosphate in the stem tissue (which is assumed to be 0.0001 molar). It is also assumed that the dominant form of precipitate will be an amorphous Pb-phosphate (Malone and others, 1974: 388).

Units: mg/day

$S_Diff_frm_Tiss = IF((STiss_Pb_Conc - SX_Pb_Conc) > 0) THEN((STiss_Pb_Conc - SX_Pb_Conc) * Diff_Coef) ELSE(0)$

DOCUMENT: If the concentration of Pb in the stem tissue is greater than that in the xylem, a diffusion gradient will be established and some Pb will diffuse from the tissue to the xylem (Marschner, 1986: 77). The diffusion flow is assumed to be proportional to the diffusion gradient and is multiplied by a diffusion coefficient.

Units: mg/day

Stock

$Stm_Phlm_Pb_Precip(t) = Stm_Phlm_Pb_Precip(t - dt) + (Stm_Phlm_Precip) * dt$

INIT $Stm_Phlm_Pb_Precip = 0$

DOCUMENT: This is the amount of Pb that is precipitated in the phloem of the stem.

Units: mg of Pb

Inflows

$Stm_Phlm_Precip = IF(SP_Pb_Conc > Sol_Prdct_Phlm) THEN(((SP_Pb_Conc - Sol_Prdct_Phlm) / SP_Pb_Conc) * Pb_Stm_Phlm * Phlm_Precip_Rte)$

$ELSE(((SP_Pb_Conc - Sol_Prdct_Phlm) / Sol_Prdct_Phlm) * Stm_Phlm_Pb_Precip * Phlm_Precip_Rte)$

DOCUMENT: This is the precipitation and or solubilization of Pb in the stem phloem. If the solution in the stem phloem is supersaturated, then some Pb will precipitate. If it is undersaturated, then some will solubilize. It is assumed that the amount that is precipitating or solubilizing is dependent upon the amount of Pb in precipitate or solution, the rate of precipitation, the total solubility of Pb at pH 8.0, the concentration of Pb in solution, and the concentration of free phosphate in the stem phloem (which is assumed to be 0.0001 molar). It is also assumed that the dominant form of precipitate will be an amorphous Pb-phosphate (Malone and others, 1974: 388).

Units: mg/day

Stock

$Stm_Tissue_Precip_Pb(t) = Stm_Tissue_Precip_Pb(t - dt) + (Stm_Tiss_Precip) * dt$

INIT $Stm_Tissue_Precip_Pb = 0$

DOCUMENT: The total amount of Pb that has been precipitated tissue in the stem tissue (symplast (excepting phloem) or apoplast (excepting xylem)). If it precipitates in the symplast, it is assumed that it will be moved outside of the symplast and into the apoplast, being deposited in the cell wall (Malone and others, 1974: 391).

Units: mg of Pb

Inflows

$Stm_Tiss_Precip = IF(Stiss_Pb_Conc > Sol_Prdct) THEN(((Stiss_Pb_Conc - Sol_Prdct) / Stiss_Pb_Conc) * Pb_Stm_Tissue * Precip_Rte)$
 $ELSE(((Stiss_Pb_Conc - Sol_Prdct) / Sol_Prdct) * Stm_Tissue_Precip_Pb * Precip_Rte)$

DOCUMENT: This is the precipitation and or solubilization of Pb in the stem tissue. If the solution in the stem tissue is supersaturated, then some Pb will precipitate. If it is undersaturated, then some will solubilize. It is assumed that the amount that is precipitating or solubilizing is dependent upon the amount of Pb in precipitate or solution, the rate of precipitation, the total solubility of Pb at pH 5.5, the concentration of Pb in solution, and the concentration of free phosphate in the stem tissue (which is assumed to be 0.0001 molar). It is also assumed that the dominant form of precipitate will be an amorphous Pb-phosphate (Malone and others, 1974: 388).

Units: mg/day

Stock

$Stm_Xylem_Pb(t) = Stm_Xylem_Pb(t - dt) + (Rt_Xy_Trns_Stm + S_Diff_frm_Tiss - Stm_Xy_to_Tissue - TrnsStmXP - Xylm_Trans_Lf - Trans_Ear_Xylm - Adsrb_SX_CW - SX_Precp) * dt$
INIT $Stm_Xylem_Pb = 0$

DOCUMENT: The mass Pb in the stem xylem. This is dependent upon the amount of Pb that has flowed into the stem xylem from the root xylem, and the amount that is diffusing back to the xylem from the symplast (parenchyma) or vice versa. (Marschner: 77) The outflows include that which is being translocated to the leaf and ear xylem, phloem, and stem tissue, and that which is precipitating.

Units: mg

Inflows

$Rt_Xy_Trns_Stm$ (IN SECTOR: Root)

$S_Diff_frm_Tiss = IF((Stiss_Pb_Conc - SX_Pb_Conc) > 0) THEN((Stiss_Pb_Conc - SX_Pb_Conc) * TransRte_Coef) ELSE(0)$

DOCUMENT: If the concentration of Pb in the stem tissue is greater than that in the xylem, a diffusion gradient will be established and some Pb will diffuse from the tissue to the xylem (Marschner, 1986: 77). The diffusion flow is assumed to be proportional to the diffusion gradient and is multiplied by a transfer rate coefficient.

Units: mg/day

Outflows

$Stm_Xy_to_Tissue = (1 - SX_CEC_Fctr) * (1 - SXP_Trns_Frac) * Stiss_X_Flw_Rte * SX_Pb_Conc$

DOCUMENT: The amount of Pb that is being translocated from the stem xylem to the stem tissue. It is dependent upon the flow rate from the xylem to the tissue and the concentration of Pb in the xylem sap. Additionally, Pb will adsorb to the xylem in the stem before it is translocated to the tissue, and it will also be transported to the phloem before being translocated to the tissue. Therefore, these two factors have a negative influence on the amount of Pb translocated to the tissue.

Units: mg of Pb/day

TrnsStmXP = RX_Flw_Rte*SXP_Trns_Frac*SX_Pb_Conc*(1-SX_CEC_Fctr)

DOCUMENT: This is the flow of Pb that is actively transferred from the xylem to the phloem along with nutrients. It is assumed to be influenced by: the concentration of the Pb in the stem xylem; the flow rate of water in the xylem, which is scaled by the xylem-phloem transfer fraction; the stem xylem CEC factor which accounts for adsorption of Pb cations on the xylem cell wall. It is also assumed that the transfer from the xylem to the phloem will be greater in the stem than in the roots (Marschner, 1986: 89)

Units: mg of Pb/day

Xylm_Trans_Lf (IN SECTOR: Leaf)

Trans_Ear_Xylm = IF(TIME<40) THEN(0) ELSE((1-SXP_Trns_Frac)*(1-SX_CEC_Fctr)*SEr_X_Flw_Rte*SX_Pb_Conc)

DOCUMENT: The amount of Pb that is being translocated from the stem to the ear via the xylem. It is dependent upon the xylem flow rate to the ear and the concentration of Pb in the xylem sap. Additionally, Pb will adsorb to the xylem in the stem before it is translocated to the ear, and it will also be transported to the phloem before being translocated to the ear. Therefore, these two factors have a negative influence on the amount of Pb translocated to the ear. Finally, there will be no xylem flow to the ear before day 40 because the ear does not begin developing until that point.

Units: mg of Pb/day

Adsrb_SX_CW = RX_Flw_Rte*SX_Pb_Conc*SX_CEC_Fctr

DOCUMENT: This is the Pb that is being adsorbed to the xylem cell wall. It is a function of the concentration of Pb in the xylem, the flow rate of the xylem, and the rate of net adsorption of Pb onto the xylem cell wall. It is assumed here that the xylem cell wall acts essentially as a cation exchanger, and other cations such as Ca²⁺ are also present in the xylem and play much more significant role in "filling" the xylem cell walls with cations to achieve breakthrough (Marschner, 1986: 73). It is also assumed that the majority of Pb in the xylem will be in the form of Pb²⁺.

Units: mg/day

SX_Precp = IF(SX_Pb_Conc>Sol_Prdct_Xylm) THEN(((SX_Pb_Conc-Sol_Prdct_Xylm)/SX_Pb_Conc)*Stm_Xylem_Pb*Xylm_Prcp_Rte)
ELSE(((SX_Pb_Conc-

Sol_Prdct_Xylm)/Sol_Prdct_Xylm)*Stm_Xylm_Pb_Prcp*Xylm_Prcp_Rte)

DOCUMENT: This is the precipitation and or solubilization of Pb in the stem xylem. If the solution in the stem xylem is supersaturated, then some Pb will precipitate. If it is undersaturated, then some will solubilize. It is assumed that the amount that is precipitating or solubilizing is dependent upon the amount of Pb in precipitate or solution, the rate of precipitation, the total solubility of Pb at pH 5.5, the concentration of Pb in solution, and the concentration of free phosphate in the stem xylem (which is assumed to be 0.0001 molar). It is also assumed that the dominant form of precipitate will be an amorphous Pb-phosphate (Malone and others, 1974: 388).

Units: mg/day

Stock

$Stm_Xylm_Pb_Prpc(t) = Stm_Xylm_Pb_Prpc(t - dt) + (SX_Prpc) * dt$

INIT $Stm_Xylm_Pb_Prpc = 0$

DOCUMENT: The amount of precipitated Pb in the stem xylem.

Units: mg of Pb

Inflows

$SX_Prpc = IF(SX_Pb_Conc > Sol_Prdct_Xylm) THEN(((SX_Pb_Conc - Sol_Prdct_Xylm) / SX_Pb_Conc) * Stm_Xylem_Pb * Xylm_Prpc_Rte)$

$ELSE(((SX_Pb_Conc - Sol_Prdct_Xylm) / Sol_Prdct_Xylm) * Stm_Xylm_Pb_Prpc * Xylm_Prpc_Rte)$

DOCUMENT: This is the precipitation and or solubilization of Pb in the stem xylem. If the solution in the stem xylem is supersaturated, then some Pb will precipitate. If it is undersaturated, then some will solubilize. It is assumed that the amount that is precipitating or solubilizing is dependent upon the amount of Pb in precipitate or solution, the rate of precipitation, the total solubility of Pb at pH 5.5, the concentration of Pb in solution, and the concentration of free phosphate in the stem xylem (which is assumed to be 0.0001 molar). It is also assumed that the dominant form of precipitate will be an amorphous Pb-phosphate (Malone and others, 1974: 388).

Units: mg/day

Stock

$SX_CW_Pb(t) = SX_CW_Pb(t - dt) + (Adsrb_SX_CW) * dt$

INIT $SX_CW_Pb = 0$

DOCUMENT: The mass of Pb that is adsorbed to the xylem cell wall.

Units; mg of Pb

Inflows

$Adsrb_SX_CW = RX_Flw_Rte * SX_Pb_Conc * SX_CEC_Fctr$

DOCUMENT: This is the Pb that is being adsorbed to the xylem cell wall. It is a function of the concentration of Pb in the xylem, the flow rate of the xylem, and the rate of net adsorption of Pb onto the xylem cell wall. It is assumed here that the xylem cell wall acts essentially as a cation exchanger, and other cations such as Ca^{2+} are also present in the xylem and play much more significant role in "filling" the xylem cell walls with cations to achieve breakthrough (Marschner, 1986: 73). It is also assumed that the majority of Pb in the xylem will be in the form of Pb^{2+} .

Units: mg/day

Parameters

$TrnsRte_Coef = 1$

DOCUMENT: This is a coefficient that is used to scale the rate at which Pb will diffuse back into the xylem if a diffusion gradient is established.

Units: liters/day

$SEr_X_Flw_Rte = RX_Flw_Rte * Er_Tsp_Fctr$

DOCUMENT: The flow rate of sap from the stem xylem to the ear xylem. It is assumed to be some fraction of the total flow rate out of the root as scaled by the ear transpiration factor. Since relatively little transpiration takes place in the stem in comparison to the leaf

or stem, this factor will always be relatively low (Marschner, 1986: 99) and (Kramer and Boyer, 1995: 204 and 228).

Units: liters/day

$SE_Phlm_Flw_Rte = LfStm_P_Flw_Rte * Er_P_Flw_Frctn$

DOCUMENT: The rate at which the phloem is flowing from the stem to the ear. It is assumed to be a product of the flow going out of the leaf into the stem and the fraction of the flow that goes to the ear vice the root.

Units: liters/day

$SP_Pb_Conc = Pb_Stm_Phlm / Stm_Phlm_Vol$

DOCUMENT: The concentration of Pb in the stem phloem. It is assumed that all Pb in the phloem is soluble.

Units: mg/liter

$STiss_Pb_Conc = Pb_Stm_Tissue / Stm_Tiss_Vol$

DOCUMENT: The concentration of soluble Pb in the tissue of the stem (symplast (excepting phloem) and apoplast (excepting xylem)).

Units: mg of Pb/liter of tissue

$STiss_X_Flw_Rte = RX_Flw_Rte * Stm_Mss_Frac * Stm_Tsp_Fctr$

DOCUMENT: The flow rate of sap from the stem xylem to the stem tissue. It is assumed to be some fraction of the flow rate out of the root to the stem as scaled by the live mass of the stem relative to the mass of the rest of the shoot and a stem transpiration factor since relatively little transpiration takes place in the stem in comparison to the leaf, though more than the ear.

Units: liter/day

$Stm_Tsp_Fctr = 1 - (Lf_Tsp_Fctr + Er_Tsp_Fctr)$

DOCUMENT: This is a factor that is used to scale the xylem flow rate into the stem with respect to its mass fraction and the total xylem flow from the root. Since the other transpiration factors have already been computed, it works out to be 1 minus the others (since all three factors together must equal one). It is assumed to vary with the mass fraction of the stem. Since less transpiration takes place in the stem than the leaf, but more than in the ear, this factor will intermediate between ear and leaf (Marschner, 1986: 99) and (Kramer and Boyer, 1995: 204 and 228).

Units: unitless

$SXP_Trns_Frac = .01$

DOCUMENT: This is a factor that describes what portion of the xylem water flow is going to the phloem. It is assumed that some Pb will be actively transported to the phloem from the xylem in the transfer cells along with this flow of water, similar to what happens with nutrients (Marschner, 1986: 89). However, it is also assumed that the fraction that is transferred to the phloem will be a small fraction of the total xylem flow. This fraction is higher in the stem than in the root.

Units: unitless

$SX_CW_Dry_Pb_Cnc = SX_CW_Pb/SX_CW_Mass$

DOCUMENT: This is the Pb that is adsorbed to the xylem cell wall per unit of dry mass of xylem cell wall.

Units: mg of Pb/kg cell wall dry mass

$SX_CW_Mass = Stm_Dry_Mass*Stm_Xylem_Fractn*Xylm_CW_Frctn$

DOCUMENT: This is the mass of the xylem cell wall of the stem.

Units: kg

$SX_Pb_Conc = Stm_Xylem_Pb/Stm_Xylm_Vol$

DOCUMENT: The concentration of soluble Pb in the stem xylem.

Units: mg of Pb/liter of xylem

Graphs

$Er_P_Flw_Frctn = GRAPH(Er_Mss_Frac)$

(0.01, 0.0045), (0.029, 0.027), (0.048, 0.09), (0.067, 0.18), (0.086, 0.315), (0.105, 0.459), (0.124, 0.581), (0.143, 0.698), (0.162, 0.797), (0.181, 0.869), (0.2, 0.9)

DOCUMENT: The fraction of the total phloem flow that comes out of the leaf that goes to the ear. It is assumed that as the ear begins to grow (i.e. the mass fraction of the ear gets larger in proportion to the rest of the shoot) the largest portion of the phloem flow that is coming out of the leaves will go to the ear instead of the root, i.e. the ear will be the largest sink. Additionally, it is also assumed that not all of the phloem flow will go to the ear, but that some small portion will go to the root even when ear growth is the greatest.

Units: unitless

$Er_Tsp_Fctr = GRAPH(Er_Mss_Frac)$

(0.01, 0.00), (0.059, 0.0045), (0.108, 0.009), (0.157, 0.014), (0.206, 0.02), (0.255, 0.0253), (0.304, 0.0303), (0.353, 0.0353), (0.402, 0.0398), (0.451, 0.0448), (0.5, 0.0498)

DOCUMENT: This is a factor that is used to scale the xylem flow rate into the ear with respect to its mass fraction and the total xylem flow from the root. It is assumed to vary with the mass fraction of the ear. Since relatively little transpiration takes place in the ear in comparison to the leaf or stem, this factor will always be relatively low (Marschner, 1986: 99) and (Kramer and Boyer, 1995: 204 and 228).

Units: unitless

$SX_CEC_Fctr = GRAPH((CEC_Goal-SX_CW_Dry_Pb_Cnc)/CEC_Goal)$

(0.00, 0.00), (0.1, 0.024), (0.2, 0.08), (0.3, 0.18), (0.4, 0.324), (0.5, 0.46), (0.6, 0.588), (0.7, 0.696), (0.8, 0.756), (0.9, 0.788), (1, 0.8)

DOCUMENT: This is a factor that is used to describe what fraction of the Pb that is flowing through the xylem will be adsorbed onto the cell wall. This factor is assumed to be influenced by the concentration of Pb in the xylem cell wall (mass/mass dry weight), and some CEC goal (Pb conc mass/dry mass). As Pb first starts moving up in the xylem, much of it is adsorbed onto the cell walls, and thus the CEC factor is high because more Pb is being adsorbed than being desorbed. Once the cell wall is "filled" with Pb, i.e. Pb concentration in the xylem cell wall approaches the CEC goal, the net adsorption will be at or near zero, because Pb is being desorbed from the xylem as fast as it is being

adsorbed. The CEC factor has a maximum value of .8. This is because it is assumed that some of the Pb will always be in complexed form and thus not adsorb to the xylem wall like Pb cations will.
Units: unitless

Ear Sector

Stock

Ear_Phlm_Pb_Precip(t) = Ear_Phlm_Pb_Precip(t - dt) + (Ear_Pb_Precip) * dt

INIT Ear_Phlm_Pb_Precip = 0

DOCUMENT: This is the amount of Pb that is precipitated in the phloem of the ear.

Units: mg of Pb

Inflows

Ear_Pb_Precip = IF(Ear_Phlm_Pb_Conc>Sol_Prdct_Phlm)

THEN(((Ear_Phlm_Pb_Conc-
Sol_Prdct_Phlm)/Ear_Phlm_Pb_Conc)*Pb_Ear_Phlm*Phlm_Precip_Rte)

ELSE(((Ear_Phlm_Pb_Conc-
Sol_Prdct_Phlm)/Sol_Prdct_Phlm)*Ear_Phlm_Pb_Precip*Phlm_Precip_Rte)

DOCUMENT: This is the precipitation and or solubilization of Pb in the ear phloem. If the solution in the ear phloem is supersaturated, then some Pb will precipitate. If it is undersaturated, then some will solubilize. It is assumed that the amount that is precipitating or solubilizing is dependent upon the amount of Pb in precipitate or solution, the rate of precipitation, the total solubility of Pb at pH 8.0, the concentration of Pb in solution, and the concentration of free phosphate in the ear phloem (which is assumed to be 0.0001 molar). It is also assumed that the dominant form of precipitate will be an amorphous Pb-phosphate (Malone and others, 1974: 388).

Units: mg/day

Stock

Ear_Tiss_Precip_Pb(t) = Ear_Tiss_Precip_Pb(t - dt) + (Ear_Tiss_Precip) * dt

INIT Ear_Tiss_Precip_Pb = 0

DOCUMENT: The total amount of Pb that has been precipitated in the ear tissue (symplast (excepting phloem) or apoplast (excepting xylem)). If it precipitates in the symplast, it assumed that it will be moved outside of the symplast and into the apoplast, being deposited in the cell wall (Malone and others, 1974: 391).

Units: mg of Pb

Inflows

Ear_Tiss_Precip = IF(Ear_Tiss_Pb_Conc>Sol_Prdct)

THEN(((Ear_Tiss_Pb_Conc-
Sol_Prdct)/Ear_Tiss_Pb_Conc)*Pb_Ear_Tissue*Precip_Rte)

ELSE(((Ear_Tiss_Pb_Conc-
Sol_Prdct)/Sol_Prdct)*Ear_Tiss_Precip_Pb*Precip_Rte)

DOCUMENT: This is the precipitation and or solubilization of Pb in the ear tissue. If the solution in the ear tissue is supersaturated, then some Pb will precipitate. If it is undersaturated, then some will solubilize. It is assumed that the amount that is precipitating or solubilizing is dependent upon the amount of Pb in precipitate or

solution, the rate of precipitation, the total solubility of Pb at pH 7, the concentration of Pb in solution, and the concentration of free phosphate in the ear tissue (which is assumed to be 0.0001 molar). It is also assumed that the dominant form of precipitate will be an amorphous Pb-phosphate (Malone and others, 1974: 388).
Units: mg/day

Stock

$Pb_Ear_Phlm(t) = Pb_Ear_Phlm(t - dt) + (Phlm_Trans_StmEar - Ear_PTiss_Trans - Ear_Pb_Precip) * dt$
INIT $Pb_Ear_Phlm = 0$

DOCUMENT: The mass of Pb in the ear phloem. The ear for the purposes of this model includes the cob, grain, silk, and leaf sheaves.

Units: mg

Inflows

$Phlm_Trans_StmEar$ (IN SECTOR: Stem)

Outflows

$Ear_PTiss_Trans = Ear_Phlm_Pb_Conc * SE_Phlm_Flw_Rte$

DOCUMENT: The flow of Pb out of the ear phloem and into the ear tissue. The flow rate out of the phloem into the ear tissue is assumed to be the same as the flow rate into the ear phloem from the stem phloem.

It is assumed that phloem flow will be from source to sink in accordance with the Munch hypothesis, with the flow being driven by the amount of photosynthate in these sources and sinks (Marschner, 1983:20-24), (Salisbury and Ross, 1992: 164 and 181), (Kochian, 1991: 249), and (Marschner, 1986: 87). The primary source for photosynthate, and thus phloem flow, is mature leaves, and the primary sinks are the roots and ear. It is assumed that Pb will move in the same direction and at the same rate as the phloem flow of photosynthate.

Units: mg of Pb/day

$Ear_Pb_Precip = IF(Ear_Phlm_Pb_Conc > Sol_Prdct_Phlm)$
THEN $((Ear_Phlm_Pb_Conc - Sol_Prdct_Phlm) / Ear_Phlm_Pb_Conc) * Pb_Ear_Phlm * Phlm_Precip_Rte$
ELSE $((Ear_Phlm_Pb_Conc - Sol_Prdct_Phlm) / Sol_Prdct_Phlm) * Ear_Phlm_Pb_Precip * Phlm_Precip_Rte$

DOCUMENT: This is the precipitation and or solubilization of Pb in the ear phloem. If the solution in the ear phloem is supersaturated, then some Pb will precipitate. If it is undersaturated, then some will solubilize. It is assumed that the amount that is precipitating or solubilizing is dependent upon the amount of Pb in precipitate or solution, the rate of precipitation, the total solubility of Pb at pH 8.0, the concentration of Pb in solution, and the concentration of free phosphate in the ear phloem (which is assumed to be 0.0001 molar). It is also assumed that the dominant form of precipitate will be an amorphous Pb-phosphate (Malone and others, 1974: 388).

Units: mg/day

Stock

$Pb_Ear_Tissue(t) = Pb_Ear_Tissue(t - dt) + (Ear_Xylm_toTiss + Ear_PTiss_Trans - Ear_Tiss_Precip) * dt$
INIT $Pb_Ear_Tissue = 0$

DOCUMENT: This includes Pb in the ear symplast (excluding the phloem) and in the apoplast (excluding the xylem) that has not been precipitated (remains soluble).

Units: mg

Inflows

Ear_Xylm_toTiss = SEr_X_Flw_Rte*Ear_X_Pb_Conc

DOCUMENT: The flow into the ear tissue will be dependent upon the flow of Pb in from the stem. It is assumed that negligible xylem to phloem transfer is taking place in the ear.

Units: mg/day

Ear_PTiss_Trans = Ear_Phlm_Pb_Conc*SE_Phlm_Flw_Rte

DOCUMENT: The flow of Pb out of the ear phloem and into the ear tissue. The flow rate out of the phloem into the ear tissue is assumed to be the same as the flow rate into the ear phloem from the stem phloem.

It is assumed that phloem flow will be from source to sink in accordance with the Munch hypothesis, with the flow being driven by the amount of photosynthate in these sources and sinks (Marschner, 1983:20-24), (Salisbury and Ross, 1992: 164 and 181), (Kochian, 1991: 249), and (Marschner, 1986: 87). The primary source for photosynthate, and thus phloem flow, is mature leaves, and the primary sinks are the roots and ear. It is assumed that Pb will move in the same direction and at the same rate as the phloem flow of photosynthate.

Units: mg of Pb/day

Outflows

Ear_Tiss_Precip = IF(Ear_Tiss_Pb_Conc>Sol_Prdct)

THEN(((Ear_Tiss_Pb_Conc-

Sol_Prdct)/Ear_Tiss_Pb_Conc)*Pb_Ear_Tissue*Precip_Rte)

ELSE(((Ear_Tiss_Pb_Conc-

Sol_Prdct)/Sol_Prdct)*Ear_Tiss_Precip_Pb*Precip_Rte)

DOCUMENT: This is the precipitation and or solubilization of Pb in the ear tissue. If the solution in the ear tissue is supersaturated, then some Pb will precipitate. If it is undersaturated, then some will solubilize. It is assumed that the amount that is precipitating or solubilizing is dependent upon the amount of Pb in precipitate or solution, the rate of precipitation, the total solubility of Pb at pH 7, the concentration of Pb in solution, and the concentration of free phosphate in the ear tissue (which is assumed to be 0.0001 molar). It is also assumed that the dominant form of precipitate will be an amorphous Pb-phosphate (Malone and others, 1974: 388).

Units: mg/day

Stock

Pb_Ear_Xylem(t) = Pb_Ear_Xylem(t - dt) + (Ear_Xylm_Frm_Stm - Ear_Xylm_toTiss) * dt

INIT Pb_Ear_Xylem = 0

DOCUMENT: The mass of Pb in the ear xylem.

Units: mg of Pb

Inflows

Ear_Xylm_Frm_Stm = Trans_Ear_Xylm

DOCUMENT: This is the mass of Pb that is being translocated from the stem xylem to the ear xylem.

Units: mg/day

Outflows

$Ear_Xylm_toTiss = SEr_X_Flw_Rte * Ear_X_Pb_Conc$

DOCUMENT: The flow into the ear tissue will be dependent upon the flow of Pb in from the stem. It is assumed that negligible xylem to phloem transfer is taking place in the ear.

Units: mg/day

Parameters

$Ear_Phlm_Pb_Conc = Pb_Ear_Phlm / Ear_Phlm_Vol$

DOCUMENT: The concentration of Pb in the ear phloem. It is assumed that all Pb in the phloem is soluble.

Units: unitless

$Ear_Tiss_Pb_Conc = Pb_Ear_Tissue / Ear_Tiss_Vol$

DOCUMENT: The concentration of soluble Pb in the tissue of the ear (symplast (excepting phloem) and apoplast (excepting xylem)).

Units: mg of Pb/liter of tissue

$Ear_X_Pb_Conc = Pb_Ear_Xylem / Ear_Xylm_Vol$

DOCUMENT: The concentration of soluble Pb in the ear xylem.

Units: mg of Pb/liter of xylem

Pb Mass and Concentration Sector

Parameters - Concentrations

$Ear_Pb_Conc = Tot_Ear_Pb / Er_Dry_Mss$

DOCUMENT: The total concentration of Pb in the ear.

Units: mg of Pb/kg dry mass of ear

$Lf_Pb_Conc = Tot_Lf_Pb / Lf_Dry_Mass$

DOCUMENT: The total concentration of Pb in the leaf.

Units: mg of Pb/kg dry mass of leaf

$Rt_Pb_Conc = Tot_Rt_Pb / Rt_Dry_Mass$

DOCUMENT: This is the total concentration of Pb in the root..

Units: mg of Pb/kg dry mass of root

$Sht_Pb_Conc = Tot_Sht_Pb / Retard_Sht_Dry_Mass$

DOCUMENT: The total concentration of Pb in the shoot.

Units: mg of Pb/kg of shoot dry mass

$Stm_Pb_Conc = Tot_Stm_Pb / Stm_Dry_Mass$

DOCUMENT: The total concentration of Pb in the stem.

Units: mg of Pb/kg dry mass of stem

Parameters - Mass

$Tot_Ear_Pb =$

$Ear_Tiss_Precip_Pb + Pb_Ear_Phlm + Pb_Ear_Xylem + Pb_Ear_Tissue + Ear_Phlm_Pb_P$
recip

DOCUMENT: The total mass of Pb in the ear.
Units: mg of Pb

Tot_Lf_Pb =
Pb_Lf_Phlm+Pb_Lf_Xlm+Lf_Tissue_Precip_Pb+Pb_Lf_Tissue+Lf_Phlm_Pb_Precip
DOCUMENT: The total mass of Pb in the leaf.
Units: mg of Pb

Tot_Rt_Pb =
Pb_Rt_Phlm+Pb_Rt_Tissue+Pb_Rt_Xylm+Rt_Tissue_Precip_Pb+Prpc_Pb_RtSrf_RCA+Rt_Xylm_CW_Pb+Rt_Xylm_Pb_Precip+Rt_Phlm_Pb_Precip+Pb_RtSurf_RCA
DOCUMENT: The total mass of Pb in the root.
Units: mg

Tot_Rt_Pb_Precip =
Prpc_Pb_RtSrf_RCA+Rt_Tissue_Precip_Pb+Rt_Xylm_Pb_Precip+Rt_Phlm_Pb_Precip
DOCUMENT: The total mass of precipitated Pb in the root.
Units: mg of Pb

Tot_Sht_Pb = Tot_Ear_Pb+Tot_Lf_Pb+Tot_Stm_Pb
DOCUMENT: The total mass of Pb in the shoot.
Units: mg of Pb

Tot_Sht_Pb_Precip =
Ear_Tiss_Precip_Pb+Lf_Tissue_Precip_Pb+Stm_Tissue_Precip_Pb+Stm_Xylm_Pb_Prcp+Lf_Phlm_Pb_Precip+Ear_Phlm_Pb_Precip+Stm_Phlm_Pb_Precip
DOCUMENT: The total mass of precipitated Pb in the shoots.
Units: mg of Pb

Tot_Stm_Pb =
Pb_Stm_Phlm+Pb_Stm_Tissue+Stm_Tissue_Precip_Pb+Stm_Xylem_Pb+Stm_CW_Pb+Stm_Xylm_Pb_Prcp+Stm_Phlm_Pb_Precip
DOCUMENT: The total mass of Pb in the stem.
Units: mg of Pb

Plant Growth and Physical Parameters Sector

Stock

Count(t) = Count(t - dt) + (Plus_1) * dt
INIT Count = 0

DOCUMENT: This is a count of the total number of days that have elapsed since the shoot quit growing. It is used in the computation of shoot mass fractions, so that if the shoot is no longer growing the mass fractions of the ear, leaf, and stem are not changing.
Units: unitless

Inflows

Plus_1 = 1*Count_Switch

DOCUMENT: This is simply a counter that keeps adding one or zero to the total count depending whether the shoot live mass is growing or not.
Units: unitless

Stock

Sht_Lve_Mass(t) = Sht_Lve_Mass(t - dt) + (Sht_Growth) * dt

INIT Sht_Lve_Mass = 0

DOCUMENT: The live mass of the maize shoots. This mass is based upon the baseline shoot dry mass growth pattern (without growth retardation), the shoot water fraction, and the retardation of plant growth that occurs due to accumulation of Pb in the plant.

Units: kg

Inflows

Sht_Growth = ((Retard_Factor)*DERIVN(Smth_Sht_Dry_Mass,1))/(1-Sht_Water_Fraction)

DOCUMENT: This is how much the live mass of the shoot grows each day. It is the product of the smooth shoot dry mass and the the growth retardation factor, and is adjusted by the shoot water fraction.

Parameters

Count_Switch = IF(Sht_Lve_Mass>DELAY(Sht_Lve_Mass,1)) THEN(0) ELSE(1)

DOCUMENT: This count switch is turned on if the shoot live mass is so retarded that it no longer is growing. In other words Pb concentration has increased to such a level that the shoot can no longer grow.

Units: unitless

Ear_Live_Mass = Sht_Lve_Mass*Er_Mss_Frac

DOCUMENT: The live mass of the ear, whose growth may be retarded by Pb concentration. Determined from the shoot live mass and the mass fraction comprising the ear.

Units: kg

Ear_Phlm_Fract = .1

DOCUMENT: The fraction of the total ear volume that is comprised of phloem. With the understanding that substantially more phloem flow goes to the ear than to any other compartment, this volume fraction is therefore assumed to be greater than for any other compartment.

Units: unitless

Ear_Phlm_Vol = Ear_Phlm_Fract*Ear_Vol

DOCUMENT: The volume of the phloem in the ear. This is computed by multiplying the fraction of the total ear volume that is phloem by the total ear volume.

Units: liters

Ear_Tiss_Fract = 1-(Ear_Phlm_Fract+Ear_Xylm_Fract)

DOCUMENT: The fraction of the total ear volume that is comprised of tissue.

Units: unitless

Ear_Tiss_Vol = Ear_Tiss_Fract*Ear_Vol

DOCUMENT: This volume includes all of the symplast of the ear with the exception of the phloem, and the apoplast with the exception of the xylem. It is derived by multiplying the fraction of the ear volume that is tissue by the total ear volume.

Units: liters

Ear_Vol = IF(TIME<.8) THEN(.000001) ELSE(Ear_Live_Mass)

DOCUMENT: The volume of the ear. It is assumed that 1 g of ear = 1 ml. The IF/THEN statement is necessary to overcome some difficulties of the software, and only applies for the 1st day.
Units: liters

Ear_Xylm_Fract = .02

DOCUMENT: The fraction of the total ear volume that is comprised of xylem. With the understanding that substantially less xylem flow goes to the ear than to the leaf, this volume fraction is therefore assumed to be less than the leaf.
Units: unitless

Ear_Xylm_Vol = Ear_Vol*Ear_Xylm_Fract

DOCUMENT: The volume of the xylem in the ear. This is computed by multiplying the fraction of the total ear volume that is xylem by the total ear volume.
Units: liters

Er_Dry_Mss = IF(TIME<.8) THEN(.000001)
ELSE(Er_Mss_Frac*Sht_Lve_Mass*(1-Sht_Water_Fraction))

DOCUMENT: The ear dry mass as retarded by Pb concentration can be determined from the shoot live mass, the leaf mass fraction, and the shoot water fraction. It is assumed that the shoot water fraction is a mass fraction. The IF/THEN statement is used to overcome a deficiency in the software, and only applies to day 1 of the simulation.
Units: kg

Lf_Dry_Mass = IF(TIME<1) THEN(.0000008)
ELSE(Lf_Mss_Frac*Sht_Lve_Mass*(1-Sht_Water_Fraction))

DOCUMENT: The leaf dry mass as retarded by Pb concentration can be determined from the shoot live mass, the leaf mass fraction, and the shoot water fraction. It is assumed that the shoot water fraction is a mass fraction. The IF/THEN statement is used to overcome a deficiency in the software, and only applies to day 1 of the simulation.
Units: kg

Lf_Live_Mass = Sht_Lve_Mass*Lf_Mss_Frac

DOCUMENT: The live mass of the leaf, whose growth may be retarded by Pb concentration. Determined from the shoot live mass and the mass fraction comprising the leaf.
Units: kg

Lf_Phlm_Fractn = .06

DOCUMENT: The fraction of the total leaf volume that is comprised of phloem. This fraction has been estimated by looking at a diagram of a cross section of a leaf (Salisbury and Ross, 1992: 71). It is also assumed that this fraction will be slightly less than in the stem.
Units: unitless

Lf_Phlm_Vol = Lf_Phlm_Fractn*Lf_Vol

DOCUMENT: The volume of the phloem in the leaf. This is computed by multiplying the fraction of the total leaf volume that is phloem by the total leaf volume.
Units: liters

Lf_Tiss_Fract = 1-(Lf_Xylm_Fractn+Lf_Phlm_Fractn)

DOCUMENT: The fraction of the total leaf volume that is comprised of tissue. This fraction has been estimated by looking at a diagram of a cross section of a leaf (Salisbury and Ross, 1992: 71).

Units: unitless

Lf_Tiss_Vol = Lf_Tiss_Fract*Lf_Vol

DOCUMENT: This volume includes all of the symplast of the leaf with the exception of the phloem, and the apoplast with the exception of the xylem. It is derived by multiplying the fraction of the leaf volume that is tissue by the total leaf volume.

Units: liters

Lf_Vol = IF (TIME<.8) THEN (.000001) ELSE(Lf_Live_Mass)

DOCUMENT: The volume of the leaf. It is assumed that 1 g of leaf = 1 ml. The IF/THEN statement is necessary to overcome some difficulties of the software, and only applies for the 1st day.

Units: liters

Lf_Xylm_Fractn = .06

DOCUMENT: The fraction of the total leaf volume that is comprised of xylem. This fraction has been estimated by looking at a diagram of a cross section of a leaf (Salisbury and Ross, 1992: 71). It is also assumed that this fraction will be slightly less than in the stem.

Units: unitless

Lf_Xylm_Vol = Lf_Vol*Lf_Xylm_Fractn

DOCUMENT: The volume of the xylem in the leaf. This is computed by multiplying the fraction of the total leaf volume that is xylem by the total leaf volume.

Units: liters

Retard_Sht_Dry_Mass = Er_Dry_Mss+Lf_Dry_Mass+Stm_Dry_Mass

DOCUMENT: This is the shoot dry mass as determined from the shoot live mass, whose growth may have been retarded by Pb uptake, and the shoot water fraction. Therefore, if the Pb concentration in the plant is high enough, growth will be retarded and this will be less than the baseline dry mass.

Units: kg

RS_RCA_Mass_Frctn = .5

DOCUMENT: This is the fraction of the total root dry mass that is comprised of the cell walls of the root surface and RCA. This figure was determined by looking at diagrams in Marschner (1986: 504) and Pitman and Cram (1973: 513).

RtSrf_RCA_Dry_Mass = RS_RCA_Mass_Frctn*Rt_Dry_Mass

DOCUMENT: This is the dry mass of the cell walls of the root surface and RCA.

Units: kg

Rt_Dry_Mass = (1-Rt_Wtr_Fraction)*Rt_Live_Mass

DOCUMENT: This is the value of the root dry mass. It is assumed that the root water fraction is a mass fraction.

Units: kg

Rt_Live_Mass = IF(TIME<1) THEN(0.0000001)

ELSE(Sht_Lve_Mass/Sht_to_Rt_ratio)

DOCUMENT: The root live mass as retarded by Pb concentration can be determined from the shoot live mass and the shoot to root ratio. The IF/THEN statement is used to overcome a deficiency in the software, and only applies to day 1 of the simulation.

Units: kg

Rt_Phlm_Frac = .05

DOCUMENT: The fraction of the total root volume that is comprised of phloem. This fraction has been estimated by looking at a diagram of a cross section of a root (Pitman and Cram, 1973: 513). It is also assumed that this fraction will be slightly less than in the stem.

Units: unitless

Rt_Phlm_Vol = Rt_Phlm_Frac*Rt_Vol

DOCUMENT: The volume of the phloem in the root. This is computed by multiplying the fraction of the total root volume that is phloem by the total root volume.

Units: liters

Rt_Tiss_Frac = 1-(Rt_Phlm_Frac+Rt_Xylm_Frac+Rt_Fr_Spce_Frac)

DOCUMENT: The fraction of the total root volume that is comprised of tissue. This fraction has been estimated by looking at a diagram of a cross section of a root (Pitman and Cram, 1973: 513).

Units: unitless

Rt_Tiss_Vol = Rt_Tiss_Frac*Rt_Vol

DOCUMENT: This volume includes all of the symplast of the root with the exception of the phloem, and the apoplast inside the stele with the exception of the xylem. It is derived by multiplying the fraction of the root volume that is tissue by the total root volume.

Units: liters

Rt_Vol = IF(TIME<.8) THEN(.0000001) ELSE(Rt_Live_Mass)

DOCUMENT: The volume of the root. It is assumed that 1 g of root = 1 ml. The IF/THEN statement is necessary to overcome some difficulties with the software, and only applies for the 1st day.

Units: liters

Rt_Xylm_Frac = .05

DOCUMENT: The fraction of the total root volume that is comprised of xylem. This fraction has been estimated by looking at a diagram of a cross section of a root (Pitman and Cram, 1973: 513). It is also assumed that this fraction will be slightly less than in the stem.

Units: unitless

Rt_Xylm_Vol = Rt_Vol*Rt_Xylm_Frac

DOCUMENT: The volume of the xylem in the root. This is computed by multiplying the fraction of the total root volume that is xylem by the total root volume.

Units: liters

Smth_Sht_Dry_Mass = SMTHN(Sht_Dry_Mass,5,3)

DOCUMENT: This is simply a function used to smooth out the shoot dry mass, which was graphed in by hand. It performs a 3rd order exponential smooth of the baseline shoot dry mass over the previous 5 days.

Units: kg

Stm_Dry_Mass = IF(TIME<1) THEN(.0000008)
ELSE(Stm_Mss_Frac*Sht_Lve_Mass*(1-Sht_Water_Fraction))

DOCUMENT: The stem dry mass as retarded by Pb concentration can be determined from the shoot live mass, the leaf mass fraction, and the shoot water fraction. It is assumed that the shoot water fraction is a mass fraction. The IF/THEN statement is used to overcome a deficiency in the software, and only applies to day 1 of the simulation.

Units: kg

Stm_Live_Mass = Sht_Lve_Mass*Stm_Mss_Frac

DOCUMENT: The live mass of the stem whose growth may be retarded by Pb concentration. Determined from the shoot live mass and the mass fraction comprising the stem.

Units: kg

Stm_Mss_Frac = SMTHN((1-(Er_Mss_Frac+Lf_Mss_Frac)),3,3)

DOCUMENT: It is assumed that the stem makes up 25% of the dry matter of maize (Hanway, 1966: 16) and Ritchie and others, 1997: website). The stem live mass fraction is assumed to be the same as the stem dry mass fraction. This function is also has a built-in factor so that if plant growth reaches zero, the ear will not continue to form, and therefore the mass fraction remains constant. This fraction is determined from the other two fraction. Additionally, the smooth function is used to smooth out "bumps" in this factor that occur due to the hand drawing of the other graphs.

Units: unitless

Stm_Phlm_Fractn = .07

DOCUMENT: The fraction of the total stem volume that is comprised of phloem. This fraction has been estimated by looking at a picture of a vascular bundle photograph of a maize stem (Fahn, 1990: 204 and 206). It is also assumed that this fraction will be higher in the stem than in the root or leaf, but not the ear.

Units: unitless

Stm_Phlm_Vol = Stm_Phlm_Fractn*Stm_Vol

DOCUMENT: The volume of the phloem in the stem. This is computed by multiplying the fraction of the total stem volume that is phloem by the total stem volume.

Units: liters

Stm_Tiss_Frac = 1-(Stm_Phlm_Fractn+Stm_Xylem_Fractn)

DOCUMENT: The fraction of the total stem volume that is comprised of tissue. This fraction has been estimated by looking at a picture of a vascular bundle photograph of a maize stem (Fahn, 1990: 204 and 206).

Units: unitless

Stm_Tiss_Vol = Stm_Tiss_Frac*Stm_Vol

DOCUMENT: This volume includes all of the symplast of the stem with the exception of the phloem, and the apoplast with the exception of the xylem. It is derived by multiplying the fraction of the stem volume that is tissue by the total stem volume.

Units: liters

Stm_Vol = IF(TIME<.8) THEN(.000001) ELSE(Stm_Live_Mass)

DOCUMENT: The volume of the stem. It is assumed that 1 g of stem = 1 ml. The IF/THEN statement is necessary to overcome some difficulties of the software, and only applies for the 1st day.

Units: liters

Stm_Xylem_Fractn = .07

DOCUMENT: The fraction of the total stem volume that is comprised of xylem. This fraction has been estimated by looking at a picture of a vascular bundle photograph of a maize stem (Fahn, 1990: 204 and 206). It is also assumed that this fraction will be higher in the stem than in the root, leaf or ear.

Units: unitless

Stm_Xylem_Vol = Stm_Xylem_Fractn*Stm_Vol

DOCUMENT: The volume of the xylem in the stem. This is computed by multiplying the fraction of the total stem volume that is xylem by the total stem volume.

Units: liters

Graphs

Er_Mss_Frac = GRAPH(TIME-Count)

(0.00, 0.00), (6.58, 0.001), (13.2, 0.001), (19.7, 0.001), (26.3, 0.001), (32.9, 0.001), (39.5, 0.001), (46.1, 0.005), (52.6, 0.02), (59.2, 0.052), (65.8, 0.0935), (72.4, 0.17), (78.9, 0.25), (85.5, 0.333), (92.1, 0.396), (98.7, 0.456), (105, 0.498), (112, 0.528), (118, 0.542), (125, 0.547)

DOCUMENT: It is assumed that the ear does not begin forming until day 50 after emergence, and that at maturity it makes up 55% of the dry matter of maize (Hanway, 1966: 16) and Ritchie and others, 1997: website). The ear live mass fraction is assumed to be the same as the ear dry mass fraction. This function is also has a built-in factor so that if plant growth reaches zero, the ear will not continue to form, and therefore the mass fraction remains constant.

Units: unitless

Lf_Mss_Frac = GRAPH(TIME-Count)

(0.00, 0.8), (10.4, 0.788), (20.8, 0.761), (31.3, 0.707), (41.7, 0.647), (52.1, 0.572), (62.5, 0.491), (72.9, 0.401), (83.3, 0.311), (93.8, 0.248), (104, 0.218), (115, 0.209), (125, 0.2)

DOCUMENT: The leaf mass fraction is assumed to vary with time, from a maximum of 80% to a minimum of 20% (Hanway, 1966: 16) and Ritchie and others, 1997: website). The leaf mass includes the leaves as well as the leaf sheaths. The leaf live mass fraction is assumed to be the same as the leaf dry mass fraction. This function is also has a built-in factor so that if plant growth reaches zero, the ear will not continue to form, and therefore the mass fraction remains constant.

Units: unitless

Retard_Factor = GRAPH(Rt_Pb_Conc)

(0.00, 1.00), (357, 0.985), (714, 0.94), (1071, 0.86), (1429, 0.745), (1786, 0.64), (2143, 0.535), (2500, 0.43), (2857, 0.335), (3214, 0.245), (3571, 0.15), (3929, 0.07), (4286, 0.03), (4643, 0.015), (5000, 0.00)

DOCUMENT: Growth of maize is retarded by uptake and translocation of Pb (Huang and Cunningham, 1996: 77). This relationship is assumed to be nearly linear, and that growth retardation will begin to occur when the root concentration reaches 1000 mg of Pb/kg, and will increase until the root concentration reaches 4000 mg/kg. At 4000 mg of Pb/kg of root dry mass, plant growth is assumed to be zero.

Units: unitless

Rt_Wtr_Fraction = GRAPH(TIME)

(0.00, 0.85), (12.5, 0.832), (25.0, 0.813), (37.5, 0.794), (50.0, 0.778), (62.5, 0.769), (75.0, 0.762), (87.5, 0.757), (100, 0.753), (113, 0.751), (125, 0.75)

DOCUMENT: The root water fraction is assumed to vary from .85 to .75 over the course of the growing season. Gavloski and others (1992: 365-366) found that about 85 percent of the mass fraction of shoots, and about 80 percent mass fraction of the roots, is water 71 days after emergence. This fraction is assumed to be a mass fraction.

Units: unitless

Sht_Dry_Mass = GRAPH(TIME)

(0.00, 0.00), (6.58, 0.001), (13.2, 0.00374), (19.7, 0.00748), (26.3, 0.015), (32.9, 0.028), (39.5, 0.047), (46.1, 0.073), (52.6, 0.107), (59.2, 0.144), (65.8, 0.183), (72.4, 0.221), (78.9, 0.258), (85.5, 0.29), (92.1, 0.316), (98.7, 0.335), (105, 0.348), (112, 0.361), (118, 0.368), (125, 0.374)

DOCUMENT: Shoot dry mass will accumulate in a sigmoidal pattern. The assumption here is that the plant matures 125 days after emergence from the soil (Hanway JJ, 1997:website), and the maximum dry weight is assumed to be 374 grams at maturity (Hanway and Russell, 1966: 949). This baseline curve will be used in the computation of many other parameters in the model.

Units: kg

Sht_to_Rt_ratio = GRAPH(TIME)

(0.00, 1.01), (12.5, 1.04), (25.0, 1.13), (37.5, 1.29), (50.0, 1.51), (62.5, 1.77), (75.0, 2.01), (87.5, 2.24), (100, 2.39), (113, 2.47), (125, 2.49)

DOCUMENT: Gavloski and others (1992: 367) found that shoot to root ratios varied from 2.5:1 to 4.1:1. Kramer and Boyer (1995: 140) cite a study by Bray that shows average shoot to root ratios for maize to be about 1.9:1. It is assumed here that early in the growing season the shoot to root ratio will be very low (0.5:1), but it will increase to 3:1 by the end of the growing season.

Units: unitless

Sht_Water_Fraction = GRAPH(TIME)
(0.00, 0.9), (12.5, 0.858), (25.0, 0.818), (37.5, 0.781), (50.0, 0.753), (62.5, 0.732), (75.0, 0.719), (87.5, 0.709), (100, 0.703), (113, 0.701), (125, 0.7)

DOCUMENT: It assumed that the water fraction in the shoots varies during the growing season from .9 at the beginning of the season to .7 at the end (Gavloski and others 1992: 365-366) and Kramer and Boyer (1995: 20). This fraction is assumed to be a weight fraction.

Units: unitless

Transpiration Sector

Stock

Maint_Trnsprtn(t) = Maint_Trnsprtn(t - dt) + (Maint_Trns_Inputs) * dt
INIT Maint_Trnsprtn = 0

DOCUMENT: This is the amount of water that a plant is transpiring each day to maintain the standing plant mass. Therefore, it is the sum of the maintenance transpiration inputs for each day of the growing season. For example, maintenance transpiration on day 3 = (total growing season transpiration required to maintain plant mass produced on day 1/124) + (total growing season transpiration required to maintain plant mass produced on day 2/123)

Units: liters/day

Inflows

Maint_Trns_Inputs = (Maint_Fctr*Trnsptn_Fctr)*(1/(125-TIME))

DOCUMENT: This is the amount of transpiration that occurs on a daily basis over the remainder of the growing season to maintain the plant mass produced on day D. It is therefore a product of the maintenance factor for day D and transpiration factor for day D, and is divided by the number of days remaining in the growing season. For example, the maintenance transpiration input for day 1 is the total growing season transpiration required to maintain plant mass produced on day 1 divided by 124.

Units: liters/day

Stock

Tot_Transpiration(t) = Tot_Transpiration(t - dt) + (Daily_Trans_Inflow) * dt

INIT Tot_Transpiration = 0

DOCUMENT: This is simply a counter that can be used to see if the transpiration as determined by the sum of daily transpiration is an accurate approximation of what it should be. It can be compared to the product of the shoot dry mass at maturity and the transpiration coefficient for a check.

Units: liters

Inflows

Daily_Trans_Inflow = Daily_Trnsptn

DOCUMENT: This is the amount of water that a maize plant is transpiring on a daily basis. It is the sum of the daily maintenance transpiration and the daily production transpiration. It is being used to compute the total transpiration over time.

Units: liters/day

Parameters

Daily_Trnsptn = Maint_Trnsprtn+Prdctn_Trnsprtn

DOCUMENT: This is the amount of water that a maize plant is transpiring on a daily basis. It is the sum of the daily maintenance transpiration and the daily production transpiration.

Units: liters/day

Maint_Fctr = 1-Prdctn_Fctr

DOCUMENT: This is a factor, varying from 0 to 1. It represents the portion of the total growing season transpiration for the unit of plant mass produced on day D (as represented by the transpiration factor) that is spent as maintenance transpiration for the remainder of the growing season.. Therefore, this factor will be very small at the beginning of the season, decrease throughout the growing season, and take on a value of 0 on the last day of the growing season. This means that for that last unit of plant mass produced on day 125, all of transpiration can be attributed new mass production and none to maintenance.

Units: unitless

Prdctn_Trnsprtn = Trnsptn_Fctr*Prdctn_Fctr

DOCUMENT: This is the amount of water that is being transpired each day in the production of new plant mass. It is therefore the product of the transpiration factor and the dry mass production factor. The dry mass production factor will be very low at the beginning of the season, increase as the season progresses, and on the last day of the season will be 1. This is because for new unit of dry mass produced early in the season, only a small portion of the total growing season transpiration for the unit of dry mass produced on day D (as represented by the transpiration factor) will go to producing it and a much higher portion of the transpiration will go to maintaining it for the remainder of the season. On the other hand, for each new unit of dry mass produced late in the season, a much higher portion of the total transpiration goes to production and a very small portion to maintenance.

Units: liters/day

Tot_Transp = (Retard_Sht_Dry_Mass*Transpiration_Coef)

DOCUMENT: This is the amount of water transpired over the entire growing season to produce and maintain the plant mass that has been produced from day 1 to day D. It is a product of the shoot dry mass on D x the transpiration coefficient.

Units: liters of water

Tot_Trans_Minus_1 = (DELAY(Retard_Sht_Dry_Mass,1)*Transpiration_Coef)

DOCUMENT: This is the amount of water transpired over the entire growing season to produce and maintain the plant mass that has been

produced from day 1 to day D-1. It is a product of the shoot dry mass on D-1 x the transpiration coefficient.

Units: liters of water

Transpiration_Coef = 349

DOCUMENT: From Mengel and Kirkby (1987:236), as well as from Forbes and Watson (1992:59), this is the amount of water (in liters) that is transpired over the course of a growing season to produce 1 kilogram of dry mass of maize. The values quoted by the two differ slightly: 349 and 329 respectively.

Units: liters of water/kg of dry mass

Trnsptn_Fctr = SMTHN((Tot_Transp-Tot_Trans_Minus_1),7,4)

DOCUMENT: This is the total amount of water transpired over the course of a growing season to produce and maintain the plant mass that has been produced on day D. Therefore, it is the difference between the (transpiration coefficient x shoot dry mass on D) and (transpiration coefficient x shoot dry mass on D-1). This factor is used in determining the amount of water that is transpired on a daily basis by a maize plant. It is assumed that this total amount of water transpired over the growing season for the additional mass produced on day D can be broken down into maintenance transpiration (the amount of transpiration required to maintain the plant mass produced on day D for the remainder of the growing season) and production transpiration (the amount of water transpired on day D to actually produce the new mass). Additional assumptions:

1 kg of water = 1 liter

Units: liters of water/day

Graphs

Prdctn_Fctr = GRAPH(TIME)

(0.00, 0.00), (11.4, 0.015), (22.7, 0.045), (34.1, 0.085), (45.5, 0.16), (56.8, 0.26), (68.2, 0.43), (79.5, 0.61), (90.9, 0.78), (102, 0.9), (114, 0.965), (125, 1.00)

DOCUMENT: This is a factor, varying from 0 to 1. It represents the portion of the total growing season transpiration for the unit of plant mass produced on day D (as represented by the transpiration factor) that is actually transpired on the day that the dry mass is produced. Therefore, this factor will be very small at the beginning of the season, increase throughout the growing season, and take on a value of 1 on the last day of the growing season. This means that for that last unit of plant mass produced on day 125, all of transpiration can be attributed new mass production and none to maintenance.

Units: unitless

Appendix C - Dry Matter Calculations for Maize

In this appendix, the average shoot dry mass of maize is computed from a study by Hanway and Russell (1969: 949)..

PlantsPerHectare := 44800 The number of plants per hectare.

kgperhectare := 16770 The kg of shoot dry mass per hectare.

$$\text{KgPerPlant} := \frac{\text{kgperhectare}}{\text{PlantsPerHectare}}$$

$$\text{KgPerPlant} = 0.374$$

Therefore, the average shoot dry mass accumulation per plant for the maize hybrids in this study is 0.374 kg over the course of a growing season.

Appendix D - Solubility Calculations for Pb

In this appendix the speciation and total solubility of Pb in aqueous solution is calculated, assuming that Pb solubility is controlled by available phosphates.

Assume that the following equations apply to phosphate species in aqueous solution, (equilibrium constants come from Morel and Hering (1993: 336-337)):

$$C_T = (\text{PO}_4) + (\text{HPO}_4) + (\text{H}_2\text{PO}_4) + (\text{H}_3\text{PO}_4)$$

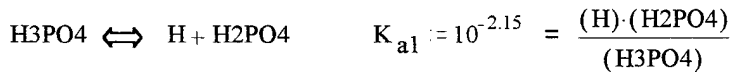
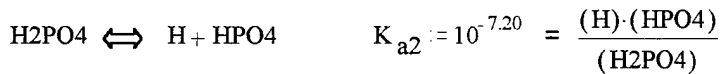
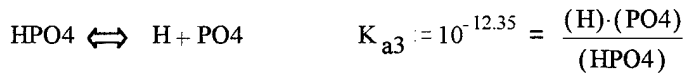

Based upon these equations, the concentrations and speciation of the phosphates will be determined as a function of total phosphate concentration in solution, holding pH constant at 7.

$$x := 4 \quad y := 1 \quad C_T := 10^{-x}, 10^{-x+1}, \dots, 10^{-y} \quad \text{H} := 10^{-7}$$

$$\text{PO}_4(C_T) := \frac{C_T}{1 + \frac{\text{H}}{K_{a3}} + \frac{\text{H}^2}{K_{a2} \cdot K_{a3}} + \frac{\text{H}^3}{K_{a1} \cdot K_{a2} \cdot K_{a3}}}$$

$$\text{HPO}_4(C_T) := \frac{\text{PO}_4(C_T) \cdot \text{H}}{K_{a3}} \quad \text{H}_2\text{PO}_4(C_T) := \frac{\text{H}^2 \cdot \text{PO}_4(C_T)}{K_{a2} \cdot K_{a3}} \quad \text{H}_3\text{PO}_4(C_T) := \frac{\text{H}^3 \cdot \text{PO}_4(C_T)}{K_{a1} \cdot K_{a2} \cdot K_{a3}}$$

A graph of the log concentrations (molar) for the phosphate species in solution as the total phosphate concentration is varied from 10^{-1} to 10^{-4} molar.

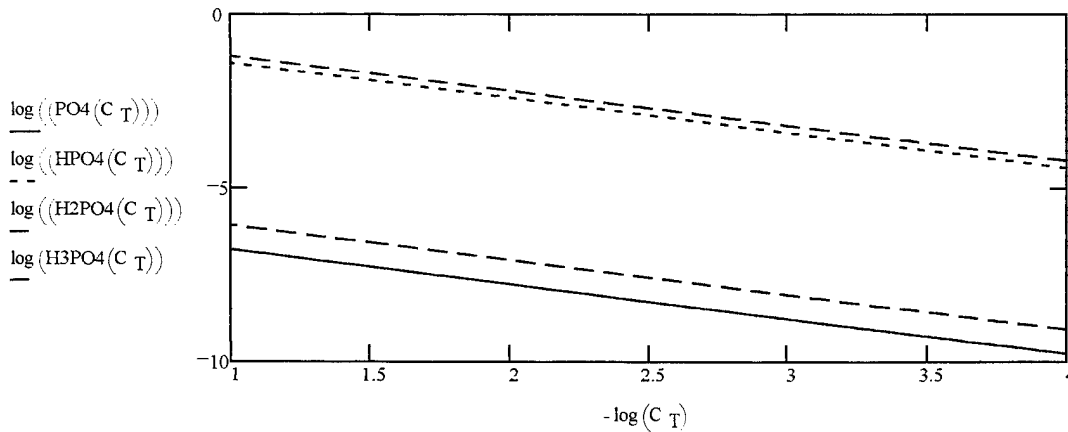

Now I will make computations and graph how the speciation changes as the pH is varied from 5 to 7.5 and the total phosphate concentration is held constant at 10^{-2} molar .

$$x := 7.5 \quad y := 5.0 \quad H := 10^{-x}, 10^{-x+1} .. 10^{-y} \quad C_T := 10^{-2}$$

Assume that the pH of tissue cells is 7 and the xylem is 5.5.

$$\text{xylem} := -\log(10^{-5.5})$$

$$\text{tissuecell} := -\log(10^{-7})$$

$$\text{PO4(H)} := \frac{C_T}{1 + \frac{H}{K_{a3}} + \frac{H^2}{K_{a2} \cdot K_{a3}} + \frac{H^3}{K_{a1} \cdot K_{a2} \cdot K_{a3}}}$$

$$\text{HPO4(H)} := \frac{\text{PO4(H)} \cdot H}{K_{a3}}$$

$$\text{H2PO4(H)} := \frac{H^2 \cdot \text{PO4(H)}}{K_{a2} \cdot K_{a3}}$$

$$\text{H3PO4(H)} := \frac{H^3 \cdot \text{PO4(H)}}{K_{a1} \cdot K_{a2} \cdot K_{a3}}$$

A graph of the log concentrations of (molar) the phosphate species as pH is varied from 5 to 7.5 and total phosphate concentration is 10^{-2} molar.

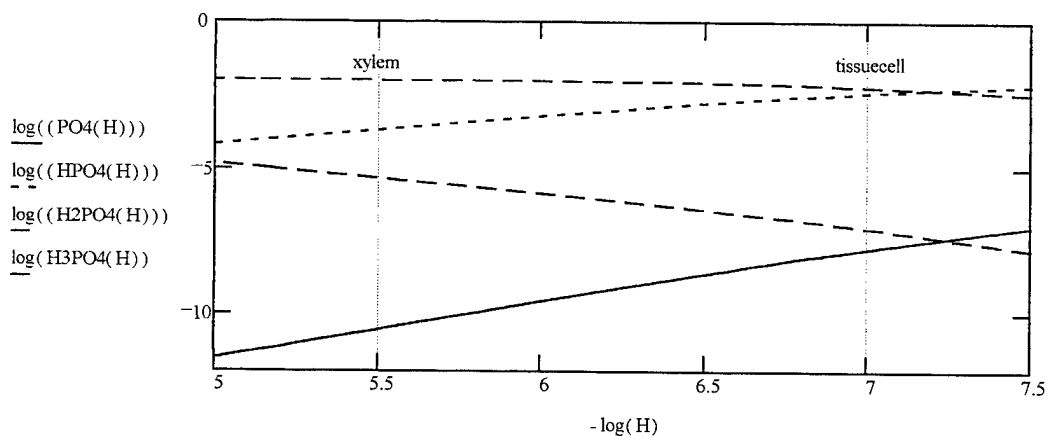

Now examining the Pb speciation. The additional following equilibrium equations apply:

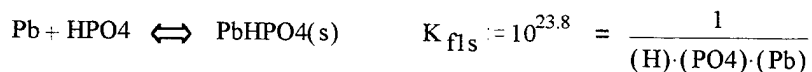
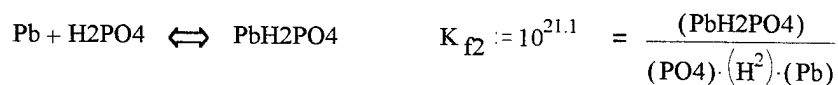
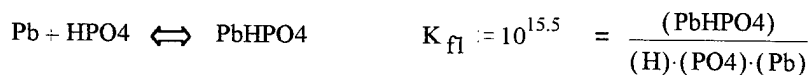

Therefore, I will start by computing the speciation of the Pb-phosphates while varying C(T) of phosphate from 10^{-1} to 10^{-6} , holding the pH constant at 7:

$$x := 6 \quad y := 1 \quad C_T := 10^{-x}, 10^{-x+1} \dots 10^{-y} \quad H := 10^{-7}$$

$$PO4(C_T) := \frac{C_T}{1 + \frac{H}{K_{a3}} + \frac{H^2}{K_{a2} \cdot K_{a3}} + \frac{H^3}{K_{a1} \cdot K_{a2} \cdot K_{a3}}}$$

$$HPO4(C_T) := \frac{PO4(C_T) \cdot H}{K_{a3}} \quad H2PO4(C_T) := \frac{H^2 \cdot PO4(C_T)}{K_{a2} \cdot K_{a3}} \quad H3PO4(C_T) := \frac{H^3 \cdot PO4(C_T)}{K_{a1} \cdot K_{a2} \cdot K_{a3}}$$

$$Pb(C_T) := \frac{1}{K_{fls} \cdot H \cdot PO4(C_T)} \quad PbHPO4(C_T) := K_{f1} \cdot H \cdot Pb(C_T) \cdot PO4(C_T)$$

$$PbH2PO4(C_T) := K_{f2} \cdot Pb(C_T) \cdot H^2 \cdot PO4(C_T)$$

Before taking a look graphically at what the Pb speciation will be for various levels of phosphate, the levels of phosphate in the soil and in plants (average) will be determined. In soil solution, phosphate levels are on the order of 10^{-5} molar (Gregory, 1988: 145). This is also the level of phosphate that was used by Huang and Cunningham (1996:76). Additionally, Marschner (1986: 5), gives a figure of 60 $\mu\text{mol/g}$ dry tissue as the average level of phosphates that are usually found in plants. Assuming that a maize plant is about 85% water, then there are 1g dry tissue/6.7 g live tissue. Also assuming that the live tissue is roughly as dense as water, then 1 g live tissue = (approximately) 1 ml, and with 1000 ml/liter gives: (60 $\mu\text{mol/}$ dry tissue) \times (1 g dry tissue/6.7 g live tissue) \times (1 g tissue/ml live tissue) \times (1000 ml/liter) = .009 molar phosphate in live tissue of plants. This is the upper limit to the amount of Pb-phosphates that could form in a plant. However, considering the importance of Pb in other plant functions, only a small fraction of that phosphate is likely to be available to bind with Pb.

$$\begin{aligned} \text{Total phosphate concentration in} & \quad \text{tissuemax} := -\log(10^{-2.05}) \\ \text{soil and plant tissue:} & \quad \text{soil} := -\log(10^{-5}) \end{aligned}$$

Log concentrations (molar) of Pb-phosphate species holding pH at 7 and varying phosphate concentration from 10^{-1} to 10^{-6} molar.

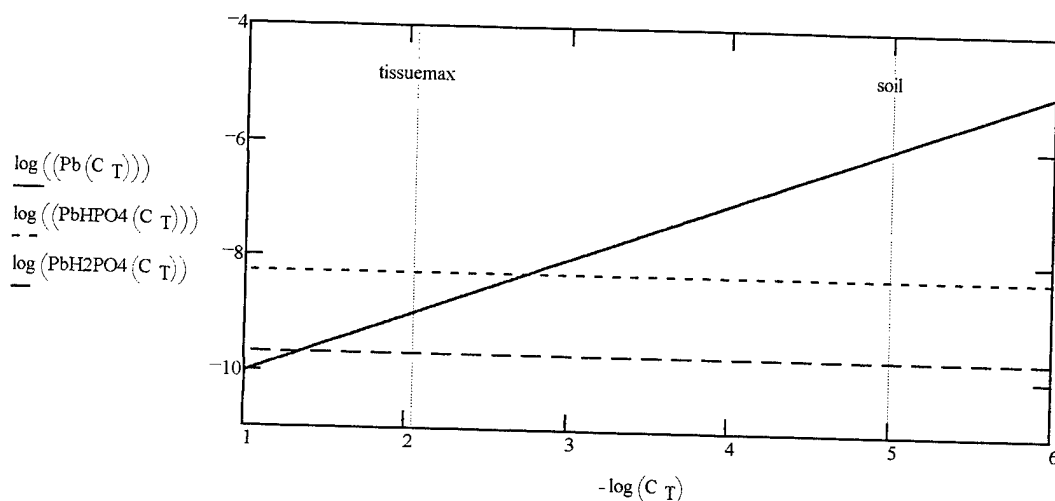

$$H := 10^{-5.5}$$

$$PO4(C_T) := \frac{C_T}{1 + \frac{H}{K_{a3}} + \frac{H^2}{K_{a2} \cdot K_{a3}} + \frac{H^3}{K_{a1} \cdot K_{a2} \cdot K_{a3}}}$$

$$HPO4(C_T) := \frac{PO4(C_T) \cdot H}{K_{a3}}$$

$$H2PO4(C_T) := \frac{H^2 \cdot PO4(C_T)}{K_{a2} \cdot K_{a3}}$$

$$Pb(C_T) := \frac{1}{K_{fls} \cdot H \cdot PO4(C_T)}$$

$$PbHPO4(C_T) := K_{fl1} \cdot H \cdot Pb(C_T) \cdot PO4(C_T)$$

$$PbH2PO4(C_T) := K_{fl2} \cdot Pb(C_T) \cdot H^2 \cdot PO4(C_T)$$

Log concentrations (molar) of Pb-phosphate species holding pH at 5.5 and varying phosphate concentration from 10^{-1} to 10^{-6} molar.

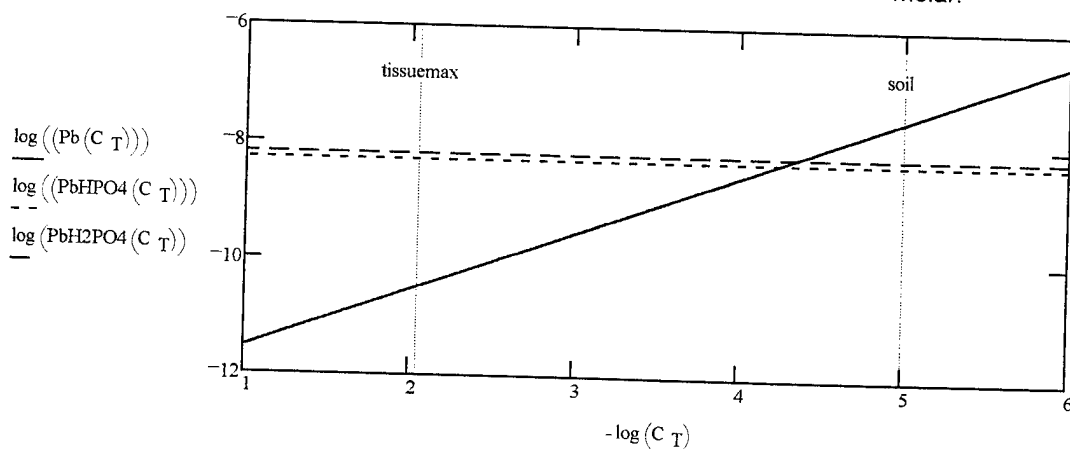

Next the speciation of Pb will be computed in the presence of phosphate holding total phosphate concentration constant and varying the pH from 5 to 7.5.

$$x := 7.5 \quad y := 5 \quad H := 10^{-x}, 10^{-x+1} .. 10^{-y} \quad C_T := .01$$

$$PO4(H) := \frac{C_T}{1 + \frac{H}{K_{a3}} + \frac{H^2}{K_{a2} \cdot K_{a3}} + \frac{H^3}{K_{a1} \cdot K_{a2} \cdot K_{a3}}}$$

$$HPO4(H) := \frac{PO4(H) \cdot H}{K_{a3}} \quad H_2PO4(H) := \frac{H^2 \cdot PO4(H)}{K_{a2} \cdot K_{a3}} \quad H_3PO4(H) := \frac{H^3 \cdot PO4(H)}{K_{a1} \cdot K_{a2} \cdot K_{a3}}$$

$$Pb(H) := \frac{1}{K_{f1s} \cdot H \cdot PO4(H)} \quad PbHPO4(H) := K_{f1} \cdot H \cdot Pb(H) \cdot PO4(H)$$

$$PbH_2PO4(H) := K_{f2} \cdot Pb(H) \cdot H^2 \cdot PO4(H) \quad \text{tissue} := -\log(10^{-7}) \quad \text{xylem} := -\log(10^{-5.5})$$

Log concentrations (molar) of Pb-phosphate species holding phosphate concentration at 10^{-2} molar and varying the pH from 5 to 7.5.

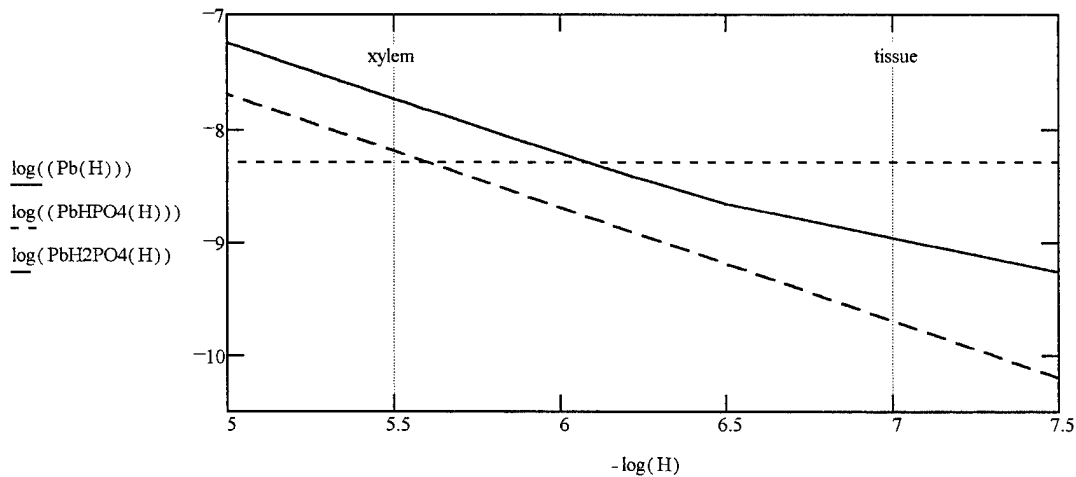

$$C_T := 10^{-4}$$

$$PO_4(H) := \frac{C_T}{1 + \frac{H}{K_{a3}} + \frac{H^2}{K_{a2} \cdot K_{a3}} + \frac{H^3}{K_{a1} \cdot K_{a2} \cdot K_{a3}}}$$

$$HPO_4(H) := \frac{PO_4(H) \cdot H}{K_{a3}}$$

$$H_2PO_4(H) := \frac{H^2 \cdot PO_4(H)}{K_{a2} \cdot K_{a3}}$$

$$Pb(H) := \frac{1}{K_{f1s} \cdot H \cdot PO_4(H)}$$

$$PbHPO_4(H) := K_{f1} \cdot H \cdot Pb(H) \cdot PO_4(H)$$

$$PbH_2PO_4(H) := K_{f2} \cdot Pb(H) \cdot H^2 \cdot PO_4(H)$$

Log concentrations (molar) of Pb-phosphate species holding phosphate concentration at 10^{-4} molar and varying the pH from 5 to 7.5.

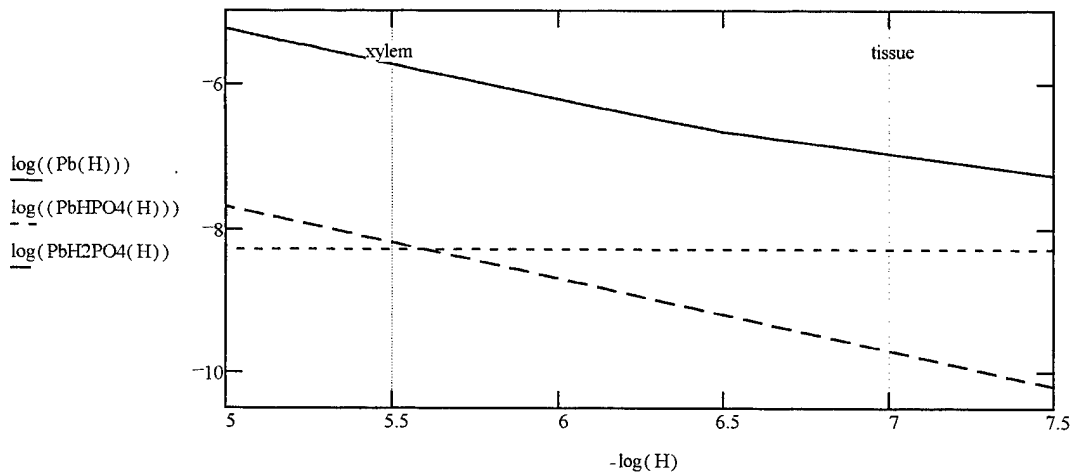

Finally, I will compute the concentrations in mg/liter at varying pH and phosphate concentrations.

Conversion factors:

$$Pb \quad \text{--} \quad 207 \text{ (g/mol)} \cdot (1000 \text{ mg/g}) = 2.07 \times 10^5$$

$$PbHPO_4 \quad \text{--} \quad 207+1+31+64 \text{ (g/mol)} \cdot (1000 \text{ mg/g}) = 3.03 \times 10^5$$

$$PbH_2PO_4 \quad \text{--} \quad 207+2+31+64 \text{ (g/mol)} \cdot (1000 \text{ mg/g}) = 3.04 \times 10^5$$

Log concentrations (mg/liter) of Pb-phosphate species holding phosphate concentration at 10^{-4} molar and varying the pH from 5.5 to 7.5.

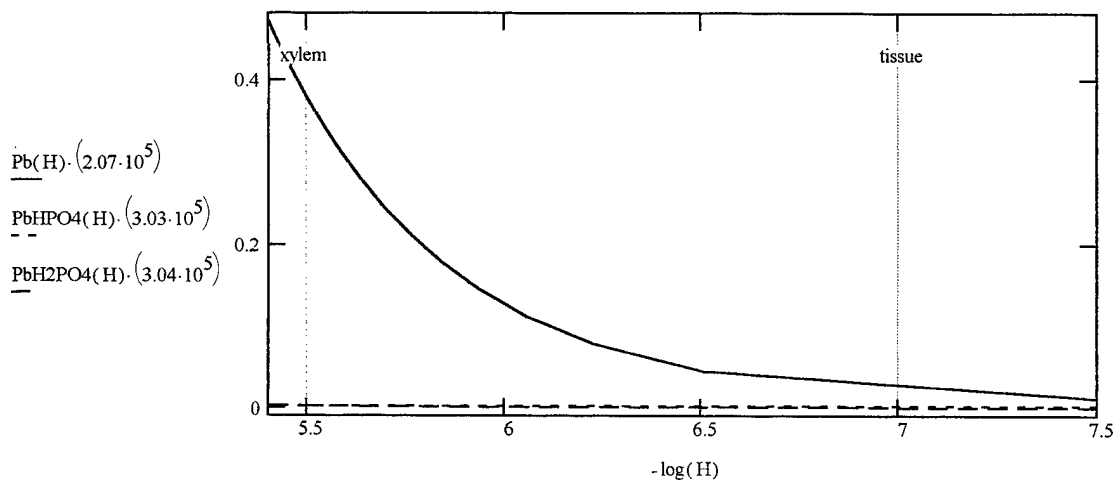

Exact values of various Pb species (mg/liter) at specified concentrations of H.

$$H := 10^{-7.0}, 10^{-6.0} \dots 10^{-5.5}$$

H	Pb(H) · (2.07 · 10 ⁵)	PbHPO4(H) · (3.03 · 10 ⁵)	PbH2PO4(H) · (3.04 · 10 ⁵)
1 · 10 ⁻⁷	0.019	1.519 · 10 ⁻³	6.066 · 10 ⁻⁵
1 · 10 ⁻⁶	0.124	1.519 · 10 ⁻³	6.066 · 10 ⁻⁴
1.9 · 10 ⁻⁶	0.229	1.519 · 10 ⁻³	1.152 · 10 ⁻³
2.8 · 10 ⁻⁶	0.333	1.519 · 10 ⁻³	1.698 · 10 ⁻³

$$H := 10^{-8.0}, 10^{-6.5} \dots 10^{-5.0}$$

$$C_T := 10^{-2} \quad \text{PO4(H)} := \frac{C_T}{1 + \frac{H}{K_{a3}} + \frac{H^2}{K_{a2} \cdot K_{a3}} + \frac{H^3}{K_{a1} \cdot K_{a2} \cdot K_{a3}}} \quad \text{HPO4(H)} := \frac{\text{PO4(H)} \cdot H}{K_{a3}}$$

$$\text{H2PO4(H)} := \frac{H^2 \cdot \text{PO4(H)}}{K_{a2} \cdot K_{a3}} \quad \text{Pb(H)} := \frac{1}{K_{fls} \cdot H \cdot \text{PO4(H)}}$$

$$\text{PbHPO4(H)} := K_{f1} \cdot H \cdot \text{Pb(H)} \cdot \text{PO4(H)}$$

$$\text{PbH2PO4(H)} = K_{f2} \cdot \text{Pb(H)} \cdot H^2 \cdot \text{PO4(H)}$$

Log concentrations (mg/liter) of Pb-phosphate species holding phosphate concentration at 10^{-4} molar and varying the pH from 5.5 to 8.0.

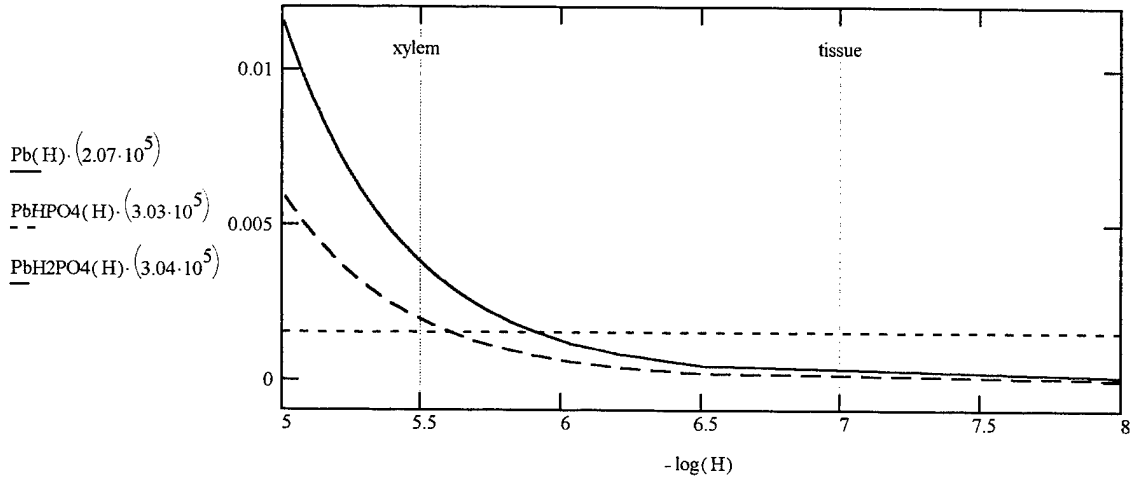

Exact values of various Pb species (mg/liter) at specified concentrations of H. $H := 10^{-8.0}, 10^{-7.0} \dots 10^{-6.5}$

H	$Pb(H) \cdot (2.07 \cdot 10^5)$	$PbHPO_4(H) \cdot (3.03 \cdot 10^5)$	$PbH_2PO_4(H) \cdot (3.04 \cdot 10^5)$
$1 \cdot 10^{-8}$	$8.509 \cdot 10^{-5}$	$1.519 \cdot 10^{-3}$	$6.066 \cdot 10^{-6}$
$1 \cdot 10^{-7}$	$1.899 \cdot 10^{-4}$	$1.519 \cdot 10^{-3}$	$6.066 \cdot 10^{-5}$
$1.9 \cdot 10^{-7}$	$2.946 \cdot 10^{-4}$	$1.519 \cdot 10^{-3}$	$1.152 \cdot 10^{-4}$
$2.8 \cdot 10^{-7}$	$3.994 \cdot 10^{-4}$	$1.519 \cdot 10^{-3}$	$1.698 \cdot 10^{-4}$

$H := 10^{-7.0}, 10^{-6.0} \dots 10^{-5.5}$

H	$Pb(H) \cdot (2.07 \cdot 10^5)$	$PbHPO_4(H) \cdot (3.03 \cdot 10^5)$	$PbH_2PO_4(H) \cdot (3.04 \cdot 10^5)$
$1 \cdot 10^{-7}$	$1.899 \cdot 10^{-4}$	$1.519 \cdot 10^{-3}$	$6.066 \cdot 10^{-5}$
$1 \cdot 10^{-6}$	$1.238 \cdot 10^{-3}$	$1.519 \cdot 10^{-3}$	$6.066 \cdot 10^{-4}$
$1.9 \cdot 10^{-6}$	$2.286 \cdot 10^{-3}$	$1.519 \cdot 10^{-3}$	$1.152 \cdot 10^{-3}$
$2.8 \cdot 10^{-6}$	$3.334 \cdot 10^{-3}$	$1.519 \cdot 10^{-3}$	$1.698 \cdot 10^{-3}$

Computing the speciation of Pb in the presence of phosphates, holding pH constant and varying phosphate concentrations.

$$x := 5 \quad y := 1.8 \quad C_T := 10^{-x}, 10^{-x+1} \dots 10^{-y}$$

$$H := 10^{-7}$$

$$PO_4(C_T) := \frac{C_T}{1 + \frac{H}{K_{a3}} + \frac{H^2}{K_{a2} \cdot K_{a3}} + \frac{H^3}{K_{a1} \cdot K_{a2} \cdot K_{a3}}}$$

$$HPO_4(C_T) := \frac{PO_4(C_T) \cdot H}{K_{a3}}$$

$$H_2PO_4(C_T) := \frac{H^2 \cdot PO_4(C_T)}{K_{a2} \cdot K_{a3}}$$

$$H_3PO_4(C_T) := \frac{H^3 \cdot PO_4(C_T)}{K_{a1} \cdot K_{a2} \cdot K_{a3}}$$

$$Pb(C_T) := \frac{1}{K_{f1s} \cdot H \cdot PO4(C_T)} \quad PbHPO4(C_T) := K_{f1} \cdot H \cdot Pb(C_T) \cdot PO4(C_T)$$

$$PbH2PO4(C_T) := K_{f2} \cdot Pb(C_T) \cdot H^2 \cdot PO4(C_T)$$

Concentrations (mg/liter) of Pb-phosphate species holding pH at 7 and varying total phosphate concentration from 10^{-2} to 10^{-5} (molar).

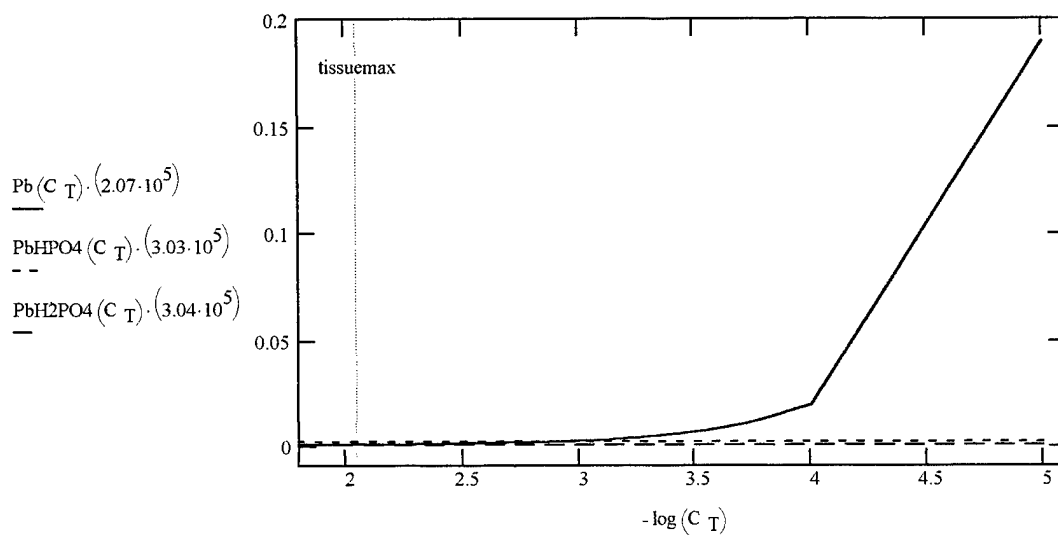

Exact values of the various species are computed given the specified C(phosphate) and pH 7 below:

$$C_T := 10^{-5} \quad \text{Pb}(C_T) \cdot (2.07 \cdot 10^5) = 0.19$$

$$\text{PbH}_2\text{PO}_4(C_T) \cdot (3.04 \cdot 10^5) = 6.066 \cdot 10^{-5} \quad \text{PbHPO}_4(C_T) \cdot (3.03 \cdot 10^5) = 1.519 \cdot 10^{-3}$$

$$\text{Pb}(C_T) \cdot (2.07 \cdot 10^5) + \text{PbHPO}_4(C_T) \cdot (3.03 \cdot 10^5) + \text{PbH}_2\text{PO}_4(C_T) \cdot (3.04 \cdot 10^5) = 0.191$$

$$C_T := 10^{-4.5} \quad \text{Pb}(C_T) \cdot (2.07 \cdot 10^5) = 0.06$$

$$\text{PbH}_2\text{PO}_4(C_T) \cdot (3.04 \cdot 10^5) = 6.066 \cdot 10^{-5} \quad \text{PbHPO}_4(C_T) \cdot (3.03 \cdot 10^5) = 1.519 \cdot 10^{-3}$$

$$\text{Pb}(C_T) \cdot (2.07 \cdot 10^5) + \text{PbHPO}_4(C_T) \cdot (3.03 \cdot 10^5) + \text{PbH}_2\text{PO}_4(C_T) \cdot (3.04 \cdot 10^5) = 0.062$$

$$C_T := 10^{-4} \quad \text{Pb}(C_T) \cdot (2.07 \cdot 10^5) = 0.019$$

$$\text{PbH}_2\text{PO}_4(C_T) \cdot (3.04 \cdot 10^5) = 6.066 \cdot 10^{-5} \quad \text{PbHPO}_4(C_T) \cdot (3.03 \cdot 10^5) = 1.519 \cdot 10^{-3}$$

$$\text{Pb}(C_T) \cdot (2.07 \cdot 10^5) + \text{PbHPO}_4(C_T) \cdot (3.03 \cdot 10^5) + \text{PbH}_2\text{PO}_4(C_T) \cdot (3.04 \cdot 10^5) = 0.021$$

$$C_T := 10^{-3.5} \quad \text{Pb}(C_T) \cdot (2.07 \cdot 10^5) = 6.004 \cdot 10^{-3}$$

$$\text{PbH}_2\text{PO}_4(C_T) \cdot (3.04 \cdot 10^5) = 6.066 \cdot 10^{-5} \quad \text{PbHPO}_4(C_T) \cdot (3.03 \cdot 10^5) = 1.519 \cdot 10^{-3}$$

$$\text{Pb}(C_T) \cdot (2.07 \cdot 10^5) + \text{PbHPO}_4(C_T) \cdot (3.03 \cdot 10^5) + \text{PbH}_2\text{PO}_4(C_T) \cdot (3.04 \cdot 10^5) = 7.583 \cdot 10^{-3}$$

$$C_T := 10^{-3} \quad \text{Pb}(C_T) \cdot (2.07 \cdot 10^5) = 1.899 \cdot 10^{-3}$$

$$\text{PbH}_2\text{PO}_4(C_T) \cdot (3.04 \cdot 10^5) = 6.066 \cdot 10^{-5} \quad \text{PbHPO}_4(C_T) \cdot (3.03 \cdot 10^5) = 1.519 \cdot 10^{-3}$$

$$\text{Pb}(C_T) \cdot (2.07 \cdot 10^5) + \text{PbHPO}_4(C_T) \cdot (3.03 \cdot 10^5) + \text{PbH}_2\text{PO}_4(C_T) \cdot (3.04 \cdot 10^5) = 3.478 \cdot 10^{-3}$$

$$C_T := 10^{-2.5} \quad \text{Pb}(C_T) \cdot (2.07 \cdot 10^5) = 6.004 \cdot 10^{-4}$$

$$\text{PbH}_2\text{PO}_4(C_T) \cdot (3.04 \cdot 10^5) = 6.066 \cdot 10^{-5} \quad \text{PbHPO}_4(C_T) \cdot (3.03 \cdot 10^5) = 1.519 \cdot 10^{-3}$$

$$\text{Pb}(C_T) \cdot (2.07 \cdot 10^5) + \text{PbHPO}_4(C_T) \cdot (3.03 \cdot 10^5) + \text{PbH}_2\text{PO}_4(C_T) \cdot (3.04 \cdot 10^5) = 2.18 \cdot 10^{-3}$$

$$C_T := 10^{-2} \quad \text{Pb}(C_T) \cdot (2.07 \cdot 10^5) = 1.899 \cdot 10^{-4}$$

$$\text{PbH}_2\text{PO}_4(C_T) \cdot (3.04 \cdot 10^5) = 6.066 \cdot 10^{-5} \quad \text{PbHPO}_4(C_T) \cdot (3.03 \cdot 10^5) = 1.519 \cdot 10^{-3}$$

$$\text{Pb}(C_T) \cdot (2.07 \cdot 10^5) + \text{PbHPO}_4(C_T) \cdot (3.03 \cdot 10^5) + \text{PbH}_2\text{PO}_4(C_T) \cdot (3.04 \cdot 10^5) = 1.769 \cdot 10^{-3}$$

When pH is 5.5 (xylem), the speciation will change as follows:

$$H := 10^{-5.5}$$

$$PO4(C_T) := \frac{C_T}{1 + \frac{H}{K_{a3}} + \frac{H^2}{K_{a2} \cdot K_{a3}} + \frac{H^3}{K_{a1} \cdot K_{a2} \cdot K_{a3}}}$$

$$HPO4(C_T) := \frac{PO4(C_T) \cdot H}{K_{a3}} \quad H2PO4(C_T) := \frac{H^2 \cdot PO4(C_T)}{K_{a2} \cdot K_{a3}} \quad H3PO4(C_T) := \frac{H^3 \cdot PO4(C_T)}{K_{a1} \cdot K_{a2} \cdot K_{a3}}$$

$$Pb(C_T) := \frac{1}{K_{fls} \cdot H \cdot PO4(C_T)} \quad PbHPO4(C_T) := K_{f1} \cdot H \cdot Pb(C_T) \cdot PO4(C_T)$$

$$PbH2PO4(C_T) := K_{f2} \cdot Pb(C_T) \cdot H^2 \cdot PO4(C_T)$$

Exact values of the various species are computed given the specified C(phosphate) and pH 5.5:

$$C_T := 10^{-5} \quad Pb(C_T) \cdot (2.07 \cdot 10^5) = 3.756$$

$$PbH2PO4(C_T) \cdot (3.04 \cdot 10^5) = 1.918 \cdot 10^{-3} \quad PbHPO4(C_T) \cdot (3.03 \cdot 10^5) = 1.519 \cdot 10^{-3}$$

$$Pb(C_T) \cdot (2.07 \cdot 10^5) + PbHPO4(C_T) \cdot (3.03 \cdot 10^5) + PbH2PO4(C_T) \cdot (3.04 \cdot 10^5) = 3.76$$

$$C_T := 10^{-4} \quad Pb(C_T) \cdot (2.07 \cdot 10^5) = 0.376$$

$$PbH2PO4(C_T) \cdot (3.04 \cdot 10^5) = 1.918 \cdot 10^{-3} \quad PbHPO4(C_T) \cdot (3.03 \cdot 10^5) = 1.519 \cdot 10^{-3}$$

$$Pb(C_T) \cdot (2.07 \cdot 10^5) + PbHPO4(C_T) \cdot (3.03 \cdot 10^5) + PbH2PO4(C_T) \cdot (3.04 \cdot 10^5) = 0.379$$

$$C_T := 10^{-3} \quad Pb(C_T) \cdot (2.07 \cdot 10^5) = 0.038$$

$$PbH2PO4(C_T) \cdot (3.04 \cdot 10^5) = 1.918 \cdot 10^{-3} \quad PbHPO4(C_T) \cdot (3.03 \cdot 10^5) = 1.519 \cdot 10^{-3}$$

$$Pb(C_T) \cdot (2.07 \cdot 10^5) + PbHPO4(C_T) \cdot (3.03 \cdot 10^5) + PbH2PO4(C_T) \cdot (3.04 \cdot 10^5) = 0.041$$

$$C_T := 10^{-2} \quad Pb(C_T) \cdot (2.07 \cdot 10^5) = 3.756 \cdot 10^{-3}$$

$$PbH2PO4(C_T) \cdot (3.04 \cdot 10^5) = 1.918 \cdot 10^{-3} \quad PbHPO4(C_T) \cdot (3.03 \cdot 10^5) = 1.519 \cdot 10^{-3}$$

$$Pb(C_T) \cdot (2.07 \cdot 10^5) + PbHPO4(C_T) \cdot (3.03 \cdot 10^5) + PbH2PO4(C_T) \cdot (3.04 \cdot 10^5) = 7.193 \cdot 10^{-3}$$

When pH is 8.0 (phloem), the speciation will change as follows:

$$H := 10^{-8.0} \quad PO4(C_T) := \frac{C_T}{1 + \frac{H}{K_{a3}} + \frac{H^2}{K_{a2} \cdot K_{a3}} + \frac{H^3}{K_{a1} \cdot K_{a2} \cdot K_{a3}}}$$

$$HPO4(C_T) := \frac{PO4(C_T) \cdot H}{K_{a3}} \quad H2PO4(C_T) := \frac{H^2 \cdot PO4(C_T)}{K_{a2} \cdot K_{a3}}$$

$$Pb(C_T) := \frac{1}{K_{f1s} \cdot H \cdot PO4(C_T)} \quad PbHPO4(C_T) := K_{f1} \cdot H \cdot Pb(C_T) \cdot PO4(C_T)$$

$$PbH2PO4(C_T) := K_{f2} \cdot Pb(C_T) \cdot H^2 \cdot PO4(C_T)$$

Exact values of the various species are computed given the specified C(phosphate) and pH 8.0:

$$C_T := 10^{-5} \quad Pb(C_T) \cdot (2.07 \cdot 10^5) = 0.085$$

$$PbH2PO4(C_T) \cdot (3.04 \cdot 10^5) = 6.066 \cdot 10^{-6} \quad PbHPO4(C_T) \cdot (3.03 \cdot 10^5) = 1.519 \cdot 10^{-3}$$

$$Pb(C_T) \cdot (2.07 \cdot 10^5) + PbHPO4(C_T) \cdot (3.03 \cdot 10^5) + PbH2PO4(C_T) \cdot (3.04 \cdot 10^5) = 0.087$$

$$C_T := 10^{-4} \quad Pb(C_T) \cdot (2.07 \cdot 10^5) = 8.509 \cdot 10^{-3}$$

$$PbH2PO4(C_T) \cdot (3.04 \cdot 10^5) = 6.066 \cdot 10^{-6} \quad PbHPO4(C_T) \cdot (3.03 \cdot 10^5) = 1.519 \cdot 10^{-3}$$

$$Pb(C_T) \cdot (2.07 \cdot 10^5) + PbHPO4(C_T) \cdot (3.03 \cdot 10^5) + PbH2PO4(C_T) \cdot (3.04 \cdot 10^5) = 0.01$$

$$C_T := 10^{-3} \quad Pb(C_T) \cdot (2.07 \cdot 10^5) = 8.509 \cdot 10^{-4}$$

$$PbH2PO4(C_T) \cdot (3.04 \cdot 10^5) = 6.066 \cdot 10^{-6} \quad PbHPO4(C_T) \cdot (3.03 \cdot 10^5) = 1.519 \cdot 10^{-3}$$

$$Pb(C_T) \cdot (2.07 \cdot 10^5) + PbHPO4(C_T) \cdot (3.03 \cdot 10^5) + PbH2PO4(C_T) \cdot (3.04 \cdot 10^5) = 2.376 \cdot 10^{-3}$$

$$C_T := 10^{-2} \quad Pb(C_T) \cdot (2.07 \cdot 10^5) = 8.509 \cdot 10^{-5}$$

$$PbH2PO4(C_T) \cdot (3.04 \cdot 10^5) = 6.066 \cdot 10^{-6} \quad PbHPO4(C_T) \cdot (3.03 \cdot 10^5) = 1.519 \cdot 10^{-3}$$

$$Pb(C_T) \cdot (2.07 \cdot 10^5) + PbHPO4(C_T) \cdot (3.03 \cdot 10^5) + PbH2PO4(C_T) \cdot (3.04 \cdot 10^5) = 1.61 \cdot 10^{-3}$$

When pH is 6.0 (soil), the speciation will change as follows:

$$H := 10^{-6.0} \quad PO4(C_T) := \frac{C_T}{1 + \frac{H}{K_{a3}} + \frac{H^2}{K_{a2} \cdot K_{a3}} + \frac{H^3}{K_{a1} \cdot K_{a2} \cdot K_{a3}}}$$

$$HPO4(C_T) := \frac{PO4(C_T) \cdot H}{K_{a3}} \quad H2PO4(C_T) := \frac{H^2 \cdot PO4(C_T)}{K_{a2} \cdot K_{a3}}$$

$$Pb(C_T) := \frac{1}{K_{fls} \cdot H \cdot PO4(C_T)} \quad PbHPO4(C_T) := K_{f1} \cdot H \cdot Pb(C_T) \cdot PO4(C_T)$$

$$PbH2PO4(C_T) := K_{f2} \cdot Pb(C_T) \cdot H^2 \cdot PO4(C_T)$$

Exact values of the various species are computed given the specified C(phosphate) and pH 6.0:

$$C_T := 10^{-5} \quad Pb(C_T) \cdot (2.07 \cdot 10^5) = 1.238$$

$$PbH2PO4(C_T) \cdot (3.04 \cdot 10^5) = 6.066 \cdot 10^{-4} \quad PbHPO4(C_T) \cdot (3.03 \cdot 10^5) = 1.519 \cdot 10^{-3}$$

$$Pb(C_T) \cdot (2.07 \cdot 10^5) + PbHPO4(C_T) \cdot (3.03 \cdot 10^5) + PbH2PO4(C_T) \cdot (3.04 \cdot 10^5) = 1.24$$

$$C_T := 10^{-4} \quad Pb(C_T) \cdot (2.07 \cdot 10^5) = 0.124$$

$$PbH2PO4(C_T) \cdot (3.04 \cdot 10^5) = 6.066 \cdot 10^{-4} \quad PbHPO4(C_T) \cdot (3.03 \cdot 10^5) = 1.519 \cdot 10^{-3}$$

$$Pb(C_T) \cdot (2.07 \cdot 10^5) + PbHPO4(C_T) \cdot (3.03 \cdot 10^5) + PbH2PO4(C_T) \cdot (3.04 \cdot 10^5) = 0.126$$

$$C_T := 10^{-3} \quad Pb(C_T) \cdot (2.07 \cdot 10^5) = 0.012$$

$$PbH2PO4(C_T) \cdot (3.04 \cdot 10^5) = 6.066 \cdot 10^{-4} \quad PbHPO4(C_T) \cdot (3.03 \cdot 10^5) = 1.519 \cdot 10^{-3}$$

$$Pb(C_T) \cdot (2.07 \cdot 10^5) + PbHPO4(C_T) \cdot (3.03 \cdot 10^5) + PbH2PO4(C_T) \cdot (3.04 \cdot 10^5) = 0.015$$

$$C_T := 10^{-2} \quad Pb(C_T) \cdot (2.07 \cdot 10^5) = 1.238 \cdot 10^{-3}$$

$$PbH2PO4(C_T) \cdot (3.04 \cdot 10^5) = 6.066 \cdot 10^{-4} \quad PbHPO4(C_T) \cdot (3.03 \cdot 10^5) = 1.519 \cdot 10^{-3}$$

$$Pb(C_T) \cdot (2.07 \cdot 10^5) + PbHPO4(C_T) \cdot (3.03 \cdot 10^5) + PbH2PO4(C_T) \cdot (3.04 \cdot 10^5) = 3.363 \cdot 10^{-3}$$

$$C_T := 10^{-6}$$

$$Pb(C_T) \cdot (2.07 \cdot 10^5) = 12.377$$

$$PbH_2PO_4(C_T) \cdot (3.04 \cdot 10^5) = 6.066 \cdot 10^{-4} \quad PbHPO_4(C_T) \cdot (3.03 \cdot 10^5) = 1.519 \cdot 10^{-3}$$

$$Pb(C_T) \cdot (2.07 \cdot 10^5) + PbHPO_4(C_T) \cdot (3.03 \cdot 10^5) + PbH_2PO_4(C_T) \cdot (3.04 \cdot 10^5) = 12.379$$

$$C_T := 10^{-7}$$

$$Pb(C_T) \cdot (2.07 \cdot 10^5) = 123.766$$

$$PbH_2PO_4(C_T) \cdot (3.04 \cdot 10^5) = 6.066 \cdot 10^{-4} \quad PbHPO_4(C_T) \cdot (3.03 \cdot 10^5) = 1.519 \cdot 10^{-3}$$

$$Pb(C_T) \cdot (2.07 \cdot 10^5) + PbHPO_4(C_T) \cdot (3.03 \cdot 10^5) + PbH_2PO_4(C_T) \cdot (3.04 \cdot 10^5) = 123.768$$

Appendix E - Determining Pb Uptake Parameters Vmax and Km

This template determines the best fit to the experimental data from Figures 1 and 3 in Huang and Cunningham (1996: 78) for the parameter values Vmax and Km that are used to describe the saturable uptake of Pb. However, before the curve fitting can be done, the experimental data must be put into the correct format.

A vector containing the micromolar concentrations of Pb grown in nutrient solution, and the corresponding Pb concentrations in the plants that was accumulated (mg/kg dry mass)

$i := 0..3$

$$\text{SolutionPbConcMM} := \begin{bmatrix} 5 \\ 20 \\ 50 \\ 100 \end{bmatrix}$$

Concentrations/Micromolar

$$\text{SolutionPbConcMI}_i := \frac{\text{SolutionPbConcMM}_i}{1000000} \cdot 207 \cdot 1000$$

$$\text{SolutionPbConcMI} = \begin{bmatrix} 1.035 \\ 4.14 \\ 10.35 \\ 20.7 \end{bmatrix}$$

Concentrations mg/liter

(Assuming 207 grams/mol of Pb)

Plant dry mass accumulations and concentrations of Pb (mg/kg dry mass).

$$\text{ShtPb} := \begin{bmatrix} 80 \\ 380 \\ 405 \\ 550 \end{bmatrix} \quad \text{ShtMass} := \begin{bmatrix} .0025 \\ .0022 \\ .0014 \\ .0013 \end{bmatrix} \quad \text{RtPb} := \begin{bmatrix} 250 \\ 2600 \\ 3200 \\ 4900 \end{bmatrix} \quad \text{RtMass} := \begin{bmatrix} .0015 \\ .0012 \\ .0007 \\ .0007 \end{bmatrix}$$

Calculating the total plant Pb using shoot and root mass and concentrations.

$$\text{PlantPb}_i := \text{ShtPb}_i \cdot \text{ShtMass}_i + \text{RtPb}_i \cdot \text{RtMass}_i$$

$$\text{PlantMass}_i := \text{ShtMass}_i + \text{RtMass}_i$$

$$\text{PlantPb} = \begin{bmatrix} 0.575 \\ 3.956 \\ 2.807 \\ 4.145 \end{bmatrix}$$

$$\text{PlantMass} = \begin{bmatrix} 4 \cdot 10^{-3} \\ 3.4 \cdot 10^{-3} \\ 2.1 \cdot 10^{-3} \\ 2 \cdot 10^{-3} \end{bmatrix}$$

Computing the daily uptake rate of Pb at each solution concentration by using the total plant mass and Pb uptake, and factoring in the length of the study (14 days).

$$\text{PlantUptakePerDay}_i := \frac{\text{PlantPb}_i}{\text{PlantMass}_i \cdot 14} \quad \text{PlantUptakePerDay} = \begin{bmatrix} 10.268 \\ 83.109 \\ 95.476 \\ 148.036 \end{bmatrix} \quad \text{SolutionPbConcMl} = \begin{bmatrix} 1.035 \\ 4.14 \\ 10.35 \\ 20.7 \end{bmatrix}$$

The equation that describes the saturable uptake process for Pb, the so-called Michaelis-Menten equation.

$$f(V_{\max}, km, c) := \frac{V_{\max} \cdot c}{km + c}$$

The first derivative of the uptake equation with respect to Vmax and km.

$$\frac{d}{dV_{\max}} f(V_{\max}, km, c) \rightarrow \frac{c}{(km + c)}$$

$$\frac{d}{dkm} f(V_{\max}, km, c) \rightarrow -V_{\max} \cdot \frac{c}{(km + c)^2}$$

Next, a matrix consisting of the uptake function and its derivatives, and the experimental uptake results and corresponding concentrations are defined.

$$F(c, \text{guess}) := \begin{bmatrix} \frac{\text{guess}_0 \cdot c}{\text{guess}_1 + c} \\ \frac{c}{(\text{guess}_1 + c)} \\ -\text{guess}_0 \cdot \frac{c}{(\text{guess}_1 + c)^2} \end{bmatrix} \quad \text{conc} := \begin{bmatrix} 1.035 \\ 4.14 \\ 10.35 \\ 20.7 \end{bmatrix} \quad \text{uptake} := \begin{bmatrix} 11.411 \\ 76.618 \\ 87.662 \\ 137.662 \end{bmatrix}$$

Next, guesses for Vmax and km will be provided, and the fitting function defined.

$$\text{guess} := \begin{pmatrix} 200 \\ 10 \end{pmatrix} \quad \text{fit} := \text{genfit}(\text{conc}, \text{uptake}, \text{guess}, F) \quad \text{fit} = \begin{pmatrix} 184.428 \\ 8.274 \end{pmatrix}$$

Finally, a curve will be plotted against the data and the correlation coefficient computed.

$$g(r) := F(r, \text{fit})_0 \quad r := 0, .01 \dots 25$$

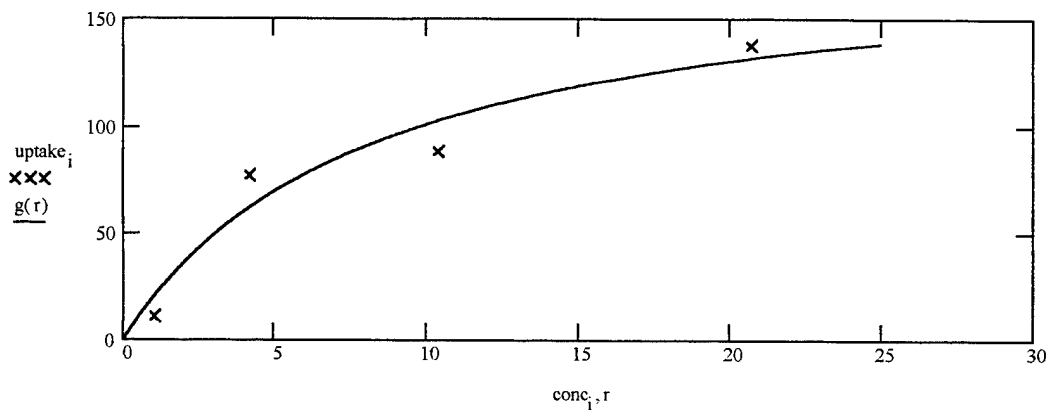

$$\text{linedata} := \begin{bmatrix} g(1.035) \\ g(4.14) \\ g(10.35) \\ g(20.7) \end{bmatrix} \quad \text{linedata}^T = (20.506 \quad 61.507 \quad 102.494 \quad 131.763)$$

$$r := \text{corr}(\text{uptake}, \text{linedata}) \quad r = 0.965 \quad r^2 = 0.931$$

Therefore the correlation coefficient of 0.931 is obtained for the parameter values and the data.

Appendix F. Model Assumptions

Model Entity	Assumption	Reference
All Compartments	Solutions are well mixed.	
Plant Growth and Physical Parameters	The growing season of a maize plant is 125 days, starting with emergence of the seedling from the soil.	Ritchie and others, 1997: website
	Shoot and root water fractions are mass fractions and decrease over the growing season.	Gavloski and others, 1992: 365-366, Kramer and Boyer, 1995: 20
	Growth will be retarded in the plant with increasing concentration of Pb in the root. Retardation will increase as root Pb concentration increases and will be complete (no plant growth) at 5000 mg Pb per kg of dry mass.	Huang and Cunningham, 1996: 77
	Root growth can be defined by a shoot to root ratio with respect to the shoot mass, that increases during the growing season.	Gavloski and others, 1992: 367, Kramer and Boyer, 1995: 140, Hanway, 1997: website
	Dry mass fractions as defined in the literature for the stem, ear, and leaves are also valid for plant live mass.	
	One gram of plant mass has a volume of one milliliter.	Lindstrom and others, 1991: 135
	The shoot mass is 0.374 kg at maturity.	Refer to Appendix 3, Hanway and Russell, 1969: 949
	Plant dry mass increase is sigmoidal.	Gardner and others, 1985: 199
Volume fractions of xylem, phloem, and tissue	Can be estimated from photographs of cross-section and figures in the literature.	Fahn, 1990: 204, 206, and 224, Salisbury and Ross, 1992: 71, Pitman and Cram, 1973: 513, Marschner, 1986: 83
All Plant Compartments	Flow in the phloem, from the tissue to phloem, and into tissue from phloem is by mass flow.	Marschner, 1986: 90, Nobel, 1991: 516, and Salisbury and Ross, 1992: 165 and 185
All Plant Compartments	Flow in the xylem, from root tissue into xylem, and into tissue from xylem is by mass flow.	Marschner, 1986: 73
Transpiration	Daily transpiration includes transpiration required to produce new plant mass and transpiration required to maintain existing plant mass.	

Model Entity	Assumption	Reference
Uptake	Pb ²⁺ is the species of Pb that is most important in describing total uptake of Pb	Lindsay 1979:334-335, McBride 1994: 336, Zimdahl and Koeppe, 1977: 102, Koeppe, 1977: 198, Huang, Chen, and Cunningham 1996: 8
Root	Movement of Pb to root surface is by mass flow and diffusion.	Gregory, 1988: 155
	Mass flow of Pb to root described by product of transpiration and solution concentration	Gregory, 1988: 155
	Diffusion and preferential binding of Pb 2+ by root can be described by a partition coefficient and partitioning rate	Marschner, 1986: 11
Precipitation	Pb will precipitate at root surface, in tissue, xylem, and phloem throughout the plant as an amorphous Pb-phosphate.	Malone and others, 1974: 388-394, University of Illinois, 1972: 210
	Precipitation of Pb is controlled by total phosphate and Pb in solution, pH, and a precipitation rate (Pb precipitation reaction in aqueous solution where phosphate is limiting)	Malone and others, 1974: 388-394, Appendix 4
	Precipitation reaction occurs quickly, and thus reaches equilibrium several times per day	Malone and others, 1974: 388-394
	Precipitation rate at the root surface and in RCA will decrease rapidly as Pb-precipitate builds up at the root surface.	Malone and others, 1974: 388
	pH is 5.5 in xylem, 8.0 in phloem, 7.0 in tissue, and 6.0 at the root surface and RCA.	Marschner, 1986: 27, 73, and 127, and Huang, Chen, and Cunningham, 1997: 4
	Soluble phosphate concentrations in plant tissue, xylem, and phloem are approximately 1% of the total phosphate concentration in plants due to binding at various sites in plant. This concentration remains constant, regardless of the level of Pb precipitation.	Marschner, 1986: 5 and 8, Cunningham, 1997: personal communication
Uptake into root symplast	Occurs in accordance with Michaelis-Menten saturation kinetics.	Nissen, 1996: 513 and many others
Xylem	Flow in the xylem out of the root to the stem is equal to the daily transpiration rates.	Kramer and Boyer, 1995: 255, Milburn, 1979: 110
	Xylem flow out of root to stem tissue, leaves or ear will be proportional to the amount of transpiration that is occurring in that compartment. Therefore, xylem flow rates to the leaves will be the highest, to the ear lowest, with stem tissue being intermediate.	Marschner, 1986: 99, Kramer and Boyer, 1995: 204 and 228

Model Entity	Assumption	Reference
	Flow of Pb in the xylem will be retarded by adsorption of Pb^{2+} to the xylem cell wall. This retardation will initially be high, decrease as Pb^{2+} cations buildup on xylem cell wall, and eventually reach zero.	Mengel and Kirkby, 1983: 212, Marschner, 1986: 73, and Kochian, 1991:248
	Retardation due to adsorption will always be less than 100% because some Pb will be transported as neutral complexes.	Clarkson and Luttge, 1989: 105, Foy and others 1978: 540
	Small fraction of Pb will be actively transported from xylem to phloem in root and stem.	Marschner, 1986: 88-89
Phloem	Phloem flow is from source to sink, with the source being the mature leaves and the sinks being the root and ear. The root will be the only sink until the ear begins to develop. Once the ear begins to develop it will become the dominant sink. Even when flow rates to the ear are at a maximum, some small fraction of the flow will still go to the root. The stem is assumed to be neither a source nor sink for phloem flow, and only serves as a conduit for flow from the leaves to the ear or root. Pb will flow along with the photosynthates from source to sink.	Marschner, 1986: 87, Kochian, 1991: 249
	Phloem flow rates will be a fraction of xylem flow rates. The fraction will increase slightly as leaves begin to mature and senesce.	Marschner, 1986: 91, Kochian, 1991: 249, Nobel, 1991: 510 and 515
Diffusion	There may be some diffusion of Pb back into the stem xylem from the stem tissue. This flow is proportional to the concentration gradient between the two and a diffusion coefficient. The diffusion between tissue and xylem in the leaves and ear is not relevant because there is no xylem flow out of these compartments. Diffusion from the root tissue to xylem is captured in the original flow into the xylem from the tissue.	Marschner, 1986: 75
Ear	Does not begin to form until day 40.	Ritchie and others, 1997: website

Appendix G – Model Output Graphs

Transfer Rate Coefficient – varied by four orders of magnitude

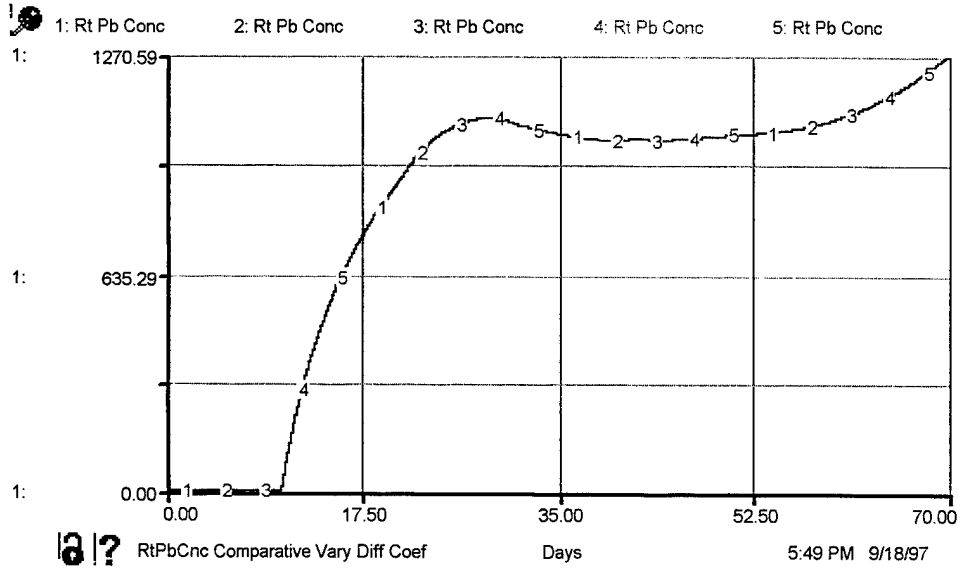

Figure 30 – Root concentrations when transfer rate coefficient is varied

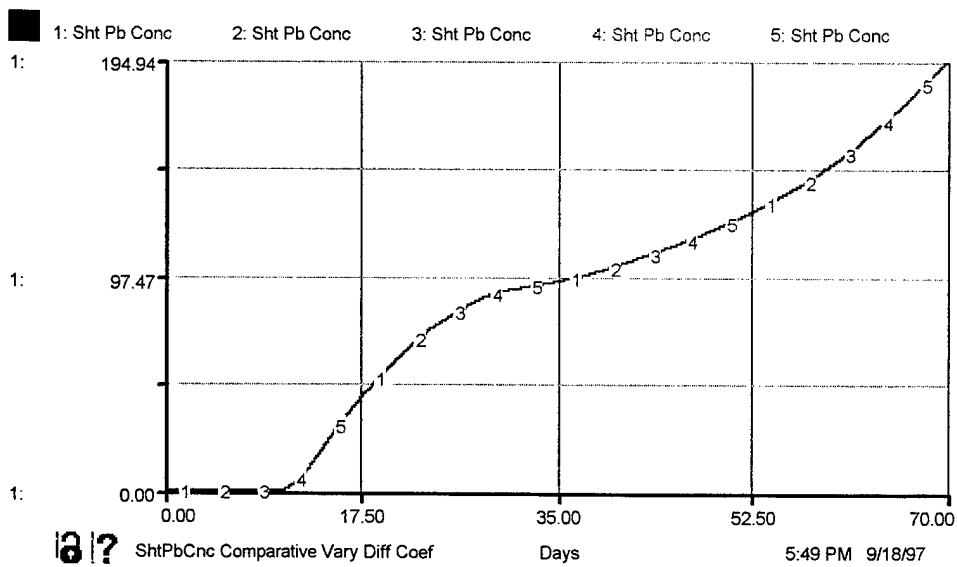

Figure 31 – Shoot Pb concentrations when transfer rate coefficient is varied

Diffusion Mechanism – with (traces 1 and 2) and without (traces 3 and 4) the diffusion mechanism in the ear and leaf, and varying the transfer rate coefficient by 4 orders of magnitude.

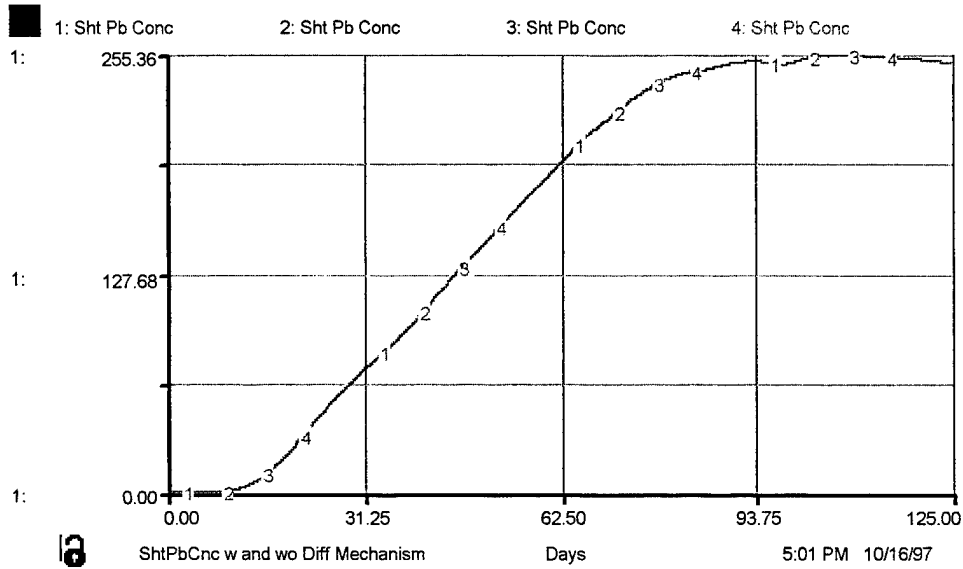

Figure 32 – Shoot concentrations with and without diffusion mechanism in ear/leaf

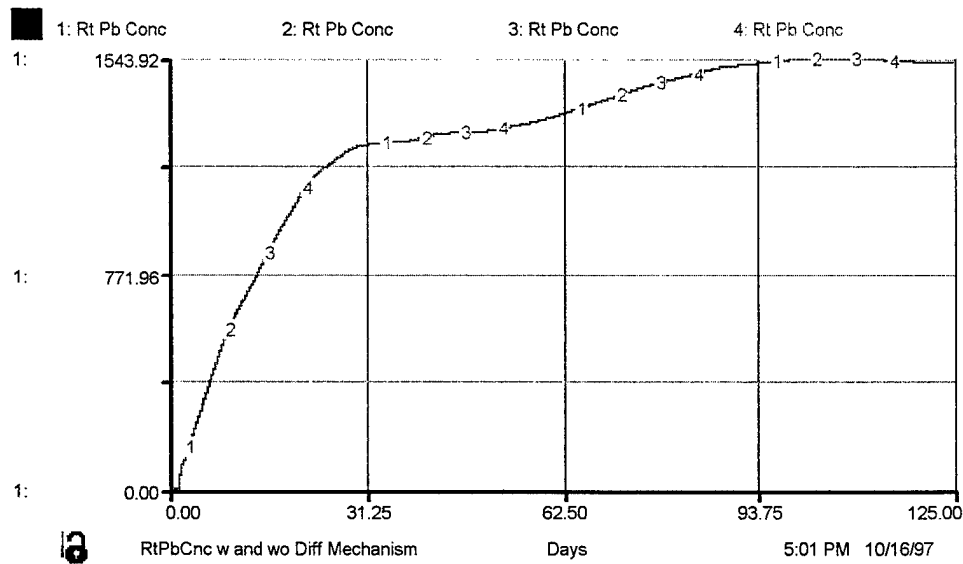

Figure 33 – Root concentrations with and without diffusion mechanism in ear/leaf

Root Surface Partition Coefficient – varied from 3 (1) to 10 (2) to 30 (3).

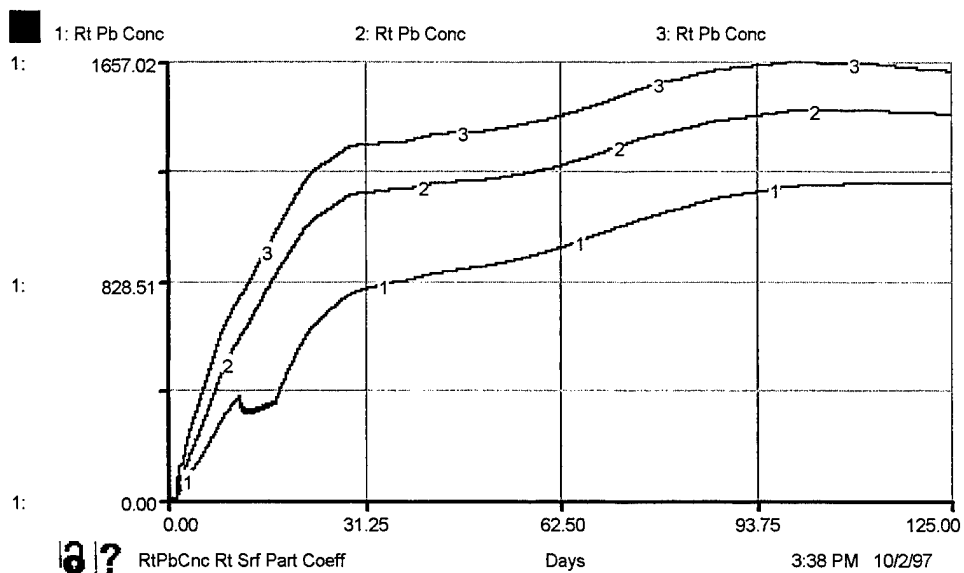

Figure 36 – Root Pb concentrations varying root surface partition coefficient

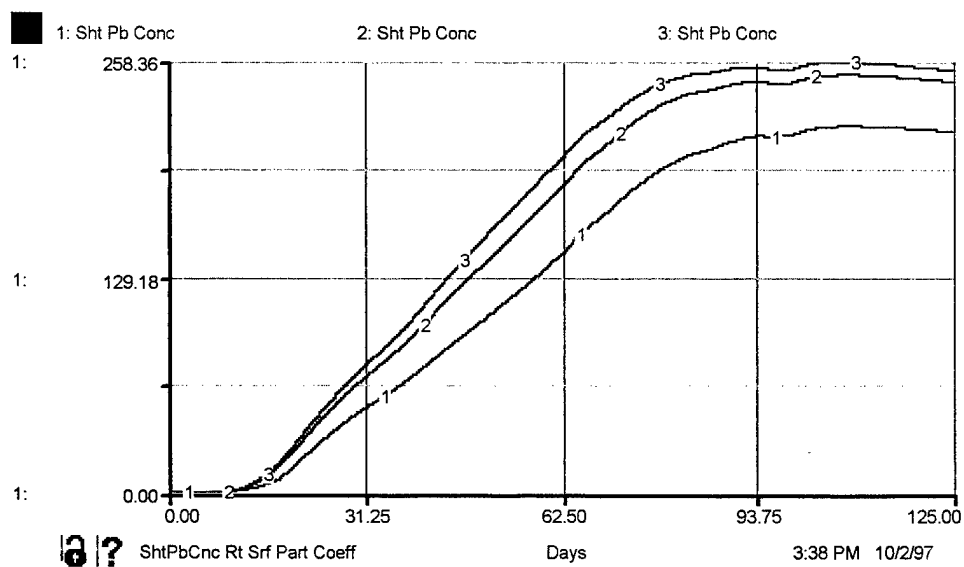

Figure 37 – Shoot Pb concentrations varying root surface partition coefficient

Solubility Products – All were varied simultaneously from one order of magnitude above the baseline (1), to the baseline (2), to two orders of magnitude below the baseline (3).

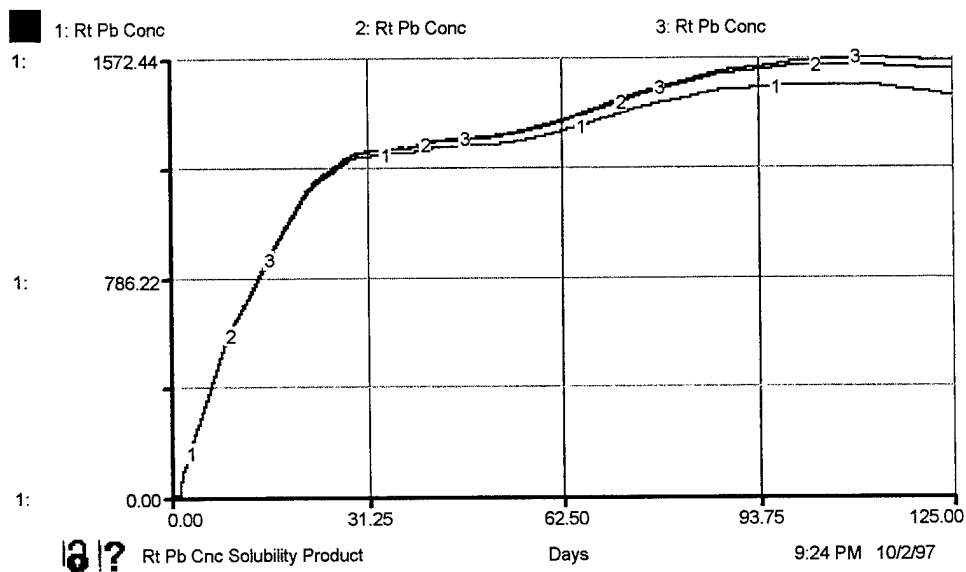

Figure 38 – Root concentrations varying the solubility product

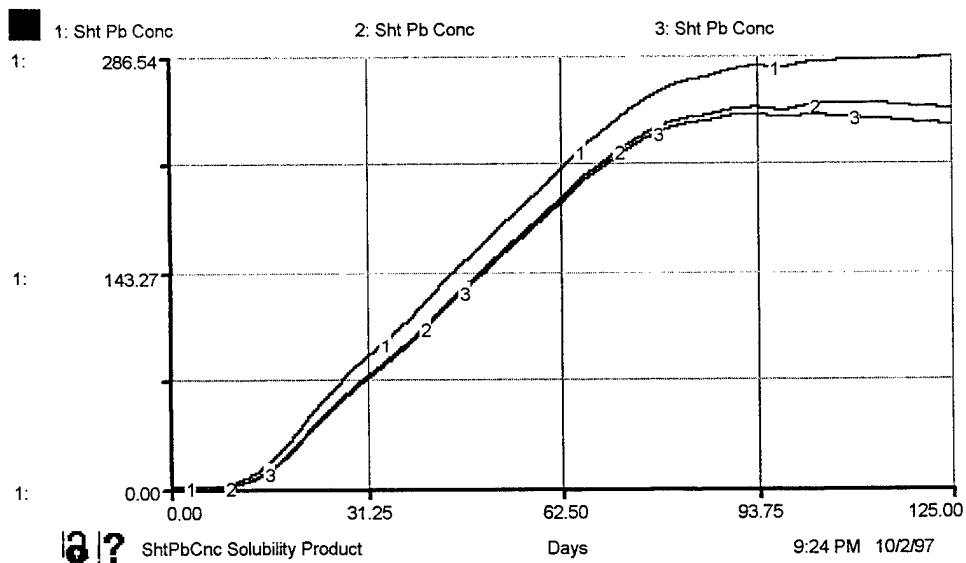

Figure 39 – Shoot concentrations varying the solubility product

Root Surface RCA Precipitation Factor (Graph) – Varied from (min-max) 0-500 (1), to baseline (0-1500, 2), to 0-5000 (3).

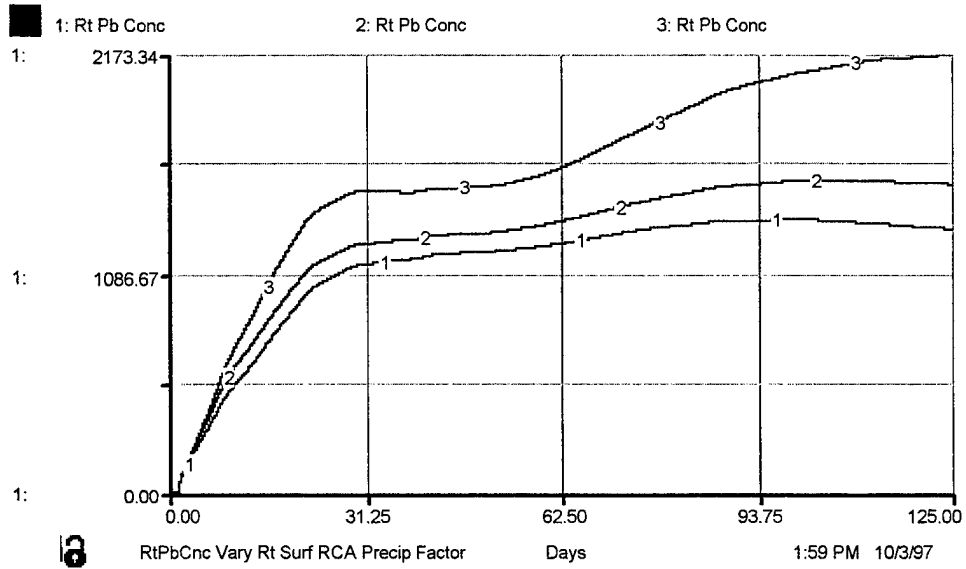

Figure 40 – Root concentration varying root surface RCA precipitation factor

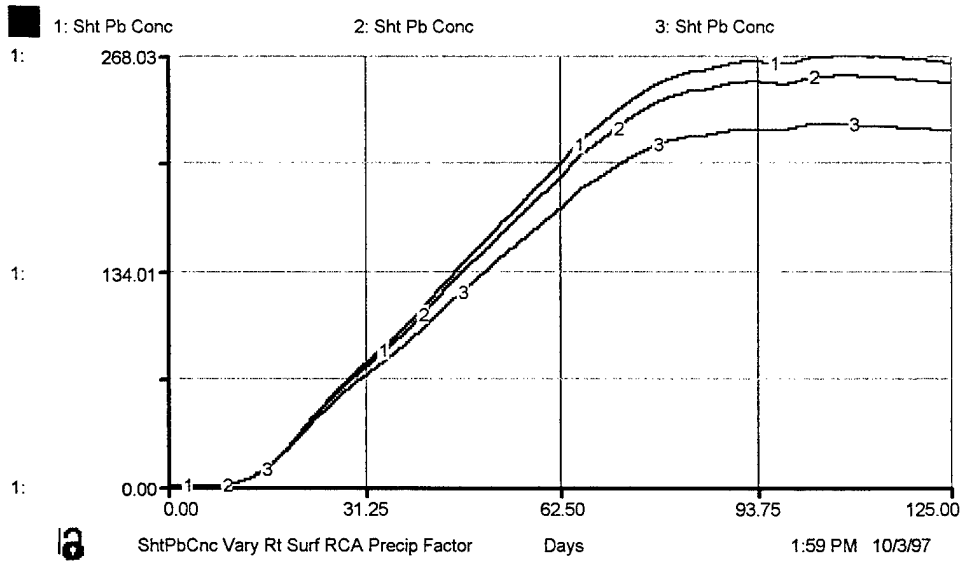

Figure 41 – Shoot concentration varying root surface RCA precipitation factor

Root Free Space Fraction – Varied from 0.04 (trace 1) to 0.08 (baseline trace 2) to 0.12 (trace 3).

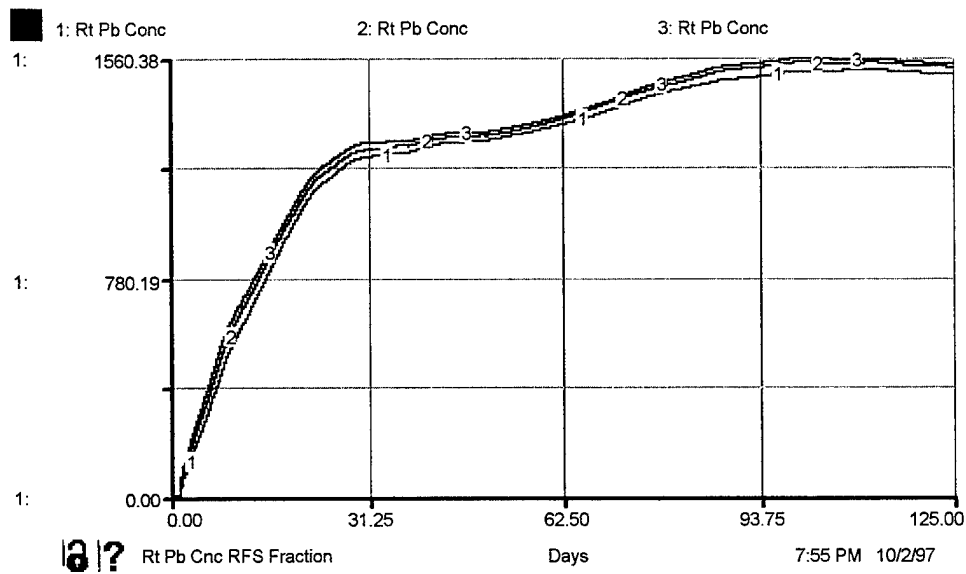

Figure 42- Root concentration varying RFS fraction

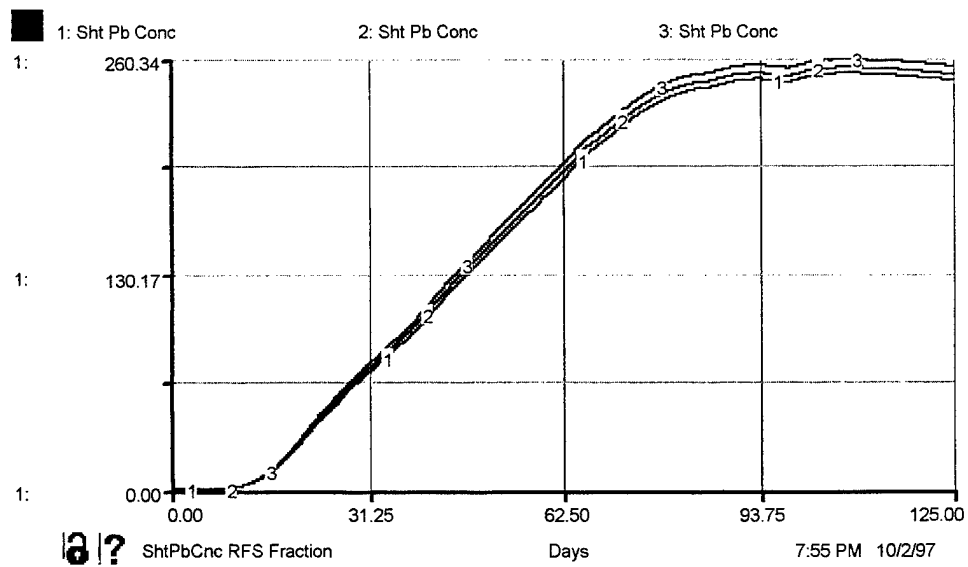

Figure 43 – Shoot concentration varying RFS fraction

K_m – Varied from 2.0 (trace 1) to 8.3 (baseline – trace 2) to 20 (trace 3).

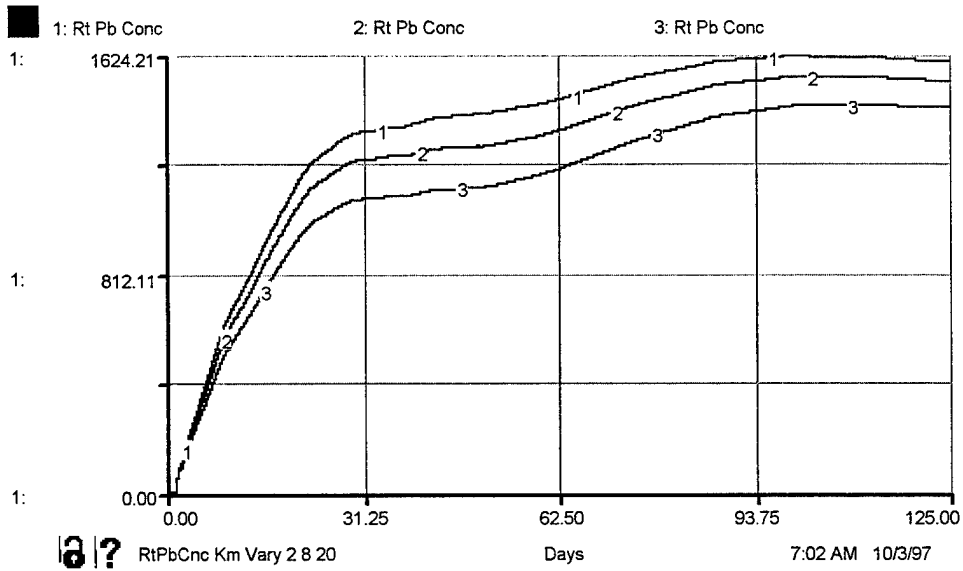

Figure 44 – Root concentration varying Km

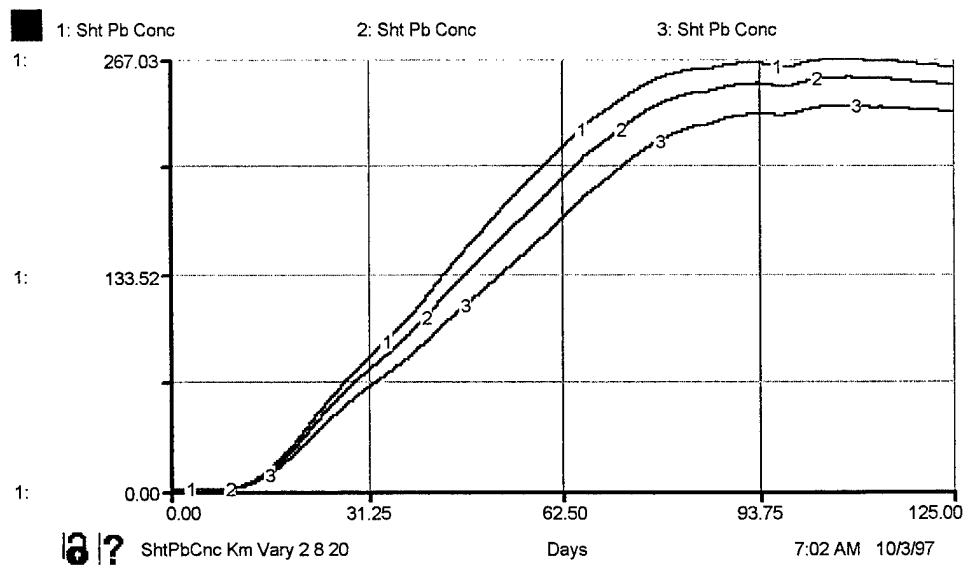

Figure 45 – Shoot concentration varying Km

Vmax – Varied from 50 (trace 1) to 184 (trace 2, baseline) to 400 (trace 3).

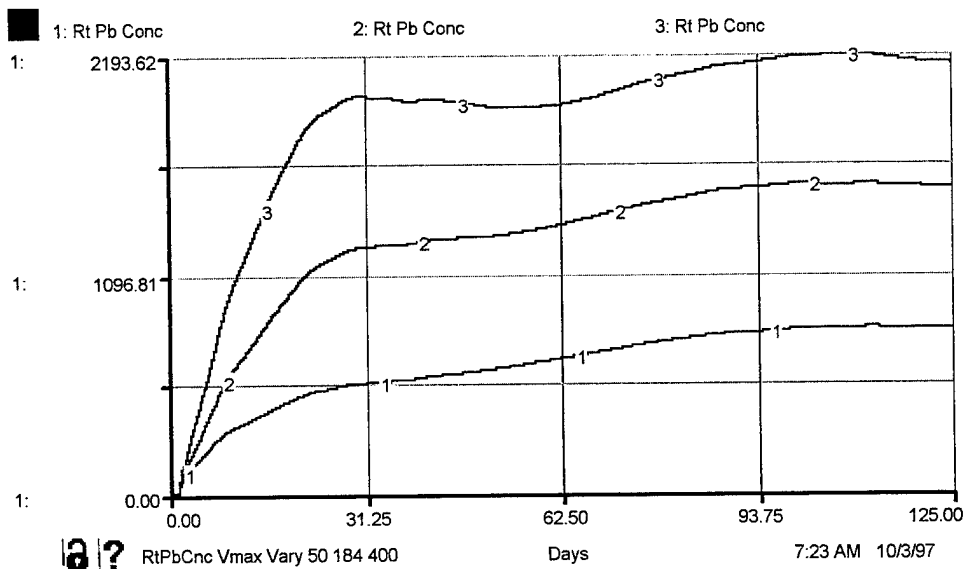

Figure 46 – Root concentration varying Vmax

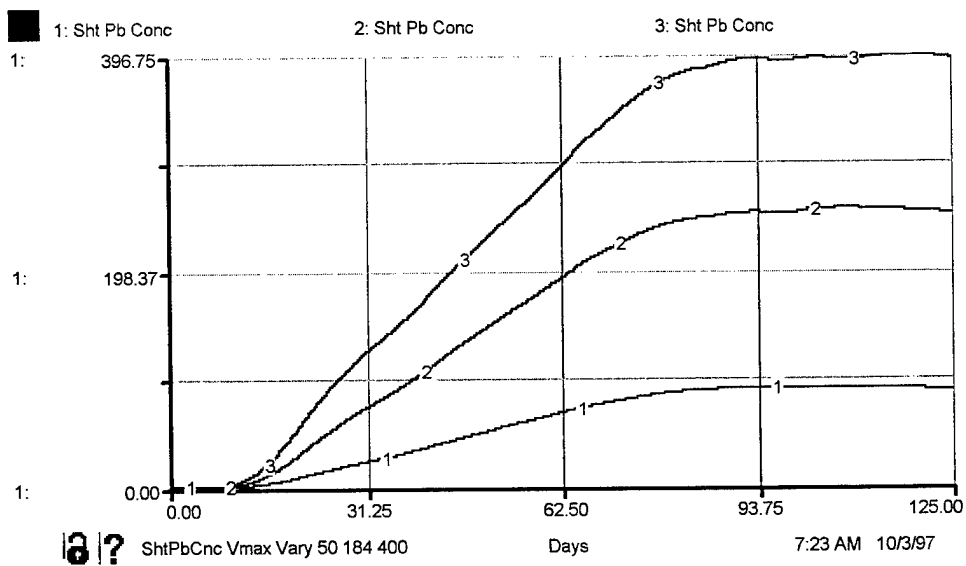

Figure 47 – Shoot concentration varying Vmax

Effective Root Mass – The endpoints of the curve remained 1 (day 0) and 0 (day 125), but the shape of the curve was varied from the baseline (sigmoidal - trace 1), to linear (trace 2), to U-shaped (trace 3).

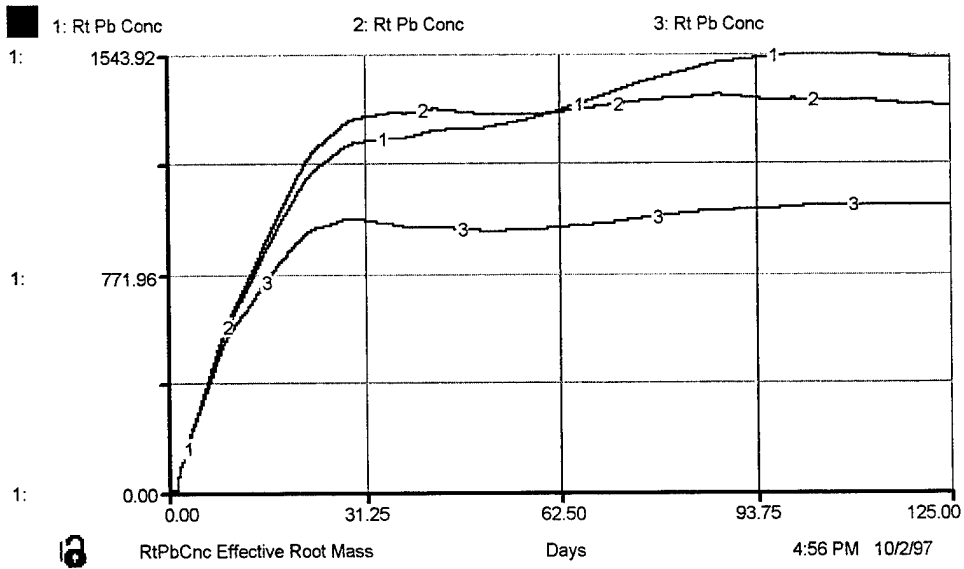

Figure 48 – Root concentration varying effective root mass

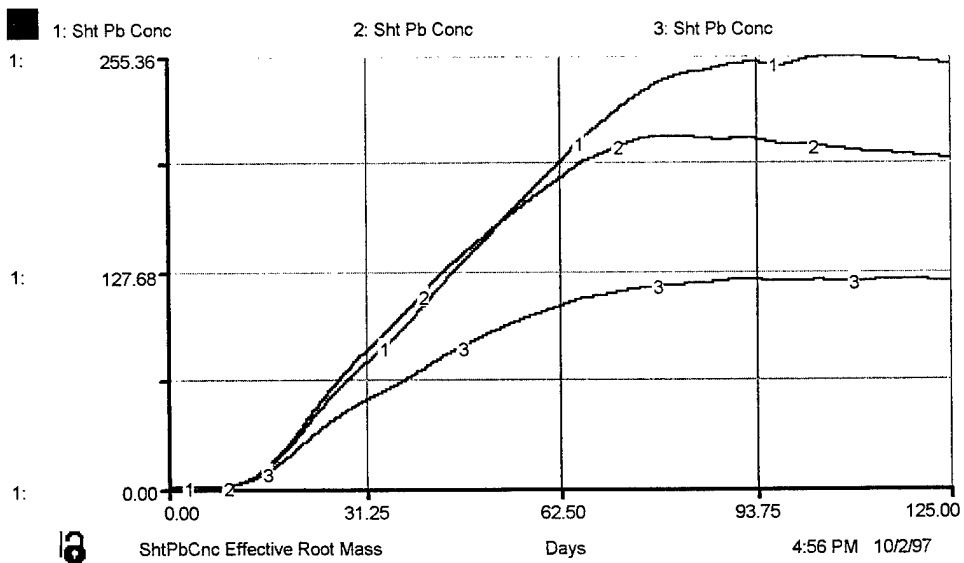

Figure 49 – Shoot concentration varying effective root mass

Growth Retardation and Vmax retardation factor – Varied from (min-max) 0-5000 (baseline trace 1), 0-8000 (trace 2), and 0-12,000 (trace 3). Shape of the curve was held constant.

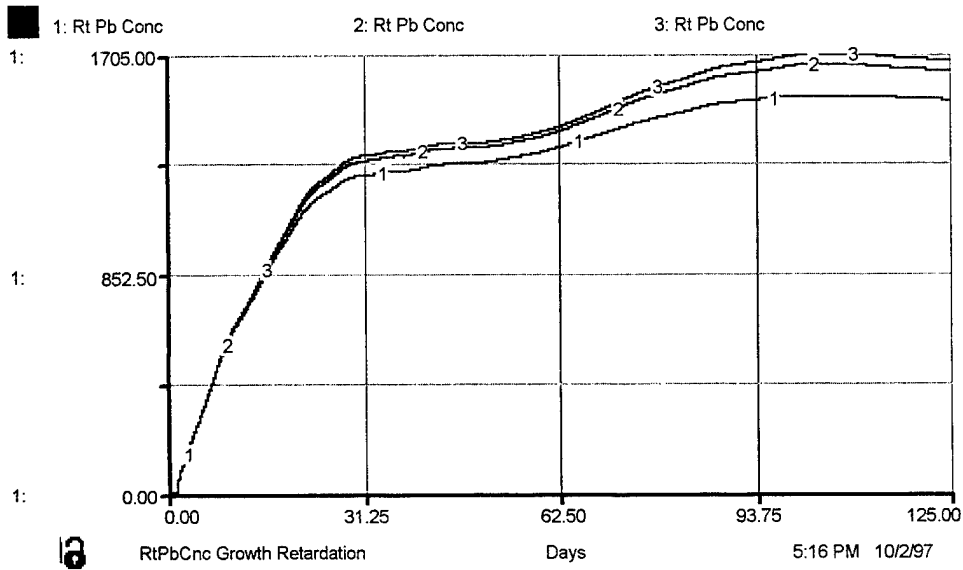

Figure 50 – Root concentration varying growth and Vmax retardation

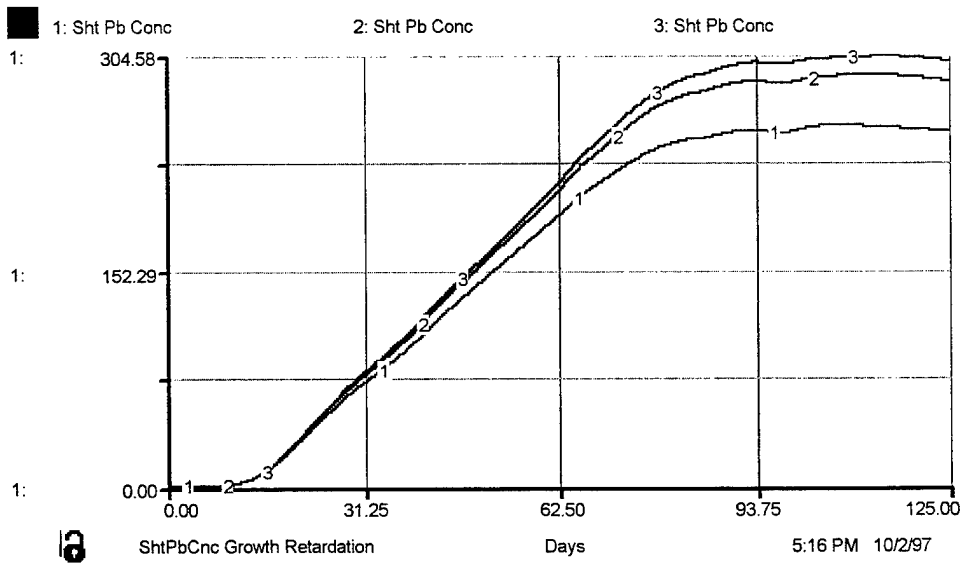

Figure 51 – Shoot concentration varying growth and Vmax retardation

Xylem CEC Goal – Varied from 200 (trace 1 - baseline), to 1000 (trace 2), to 8000 (trace 3)

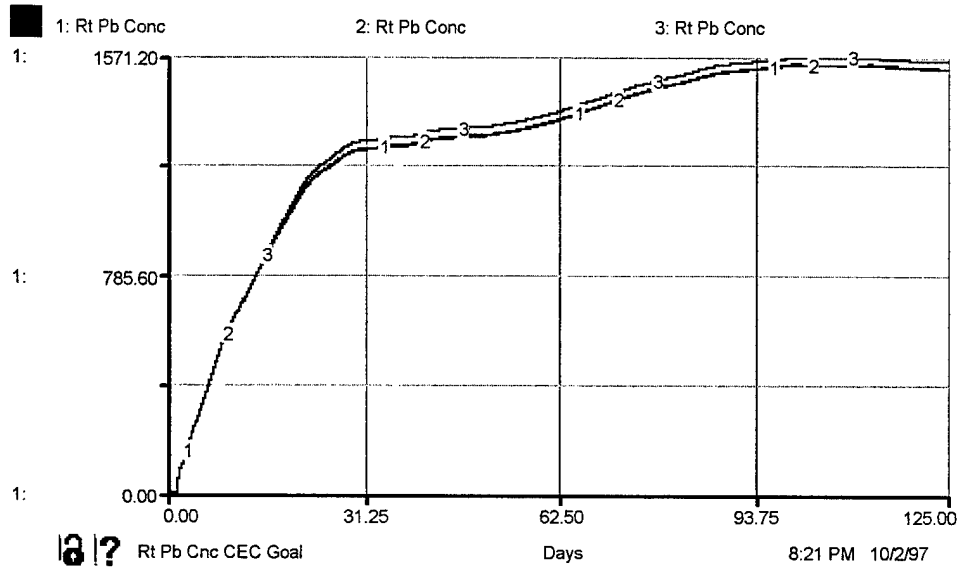

Figure 52 – Root concentrations varying xylem CEC goal

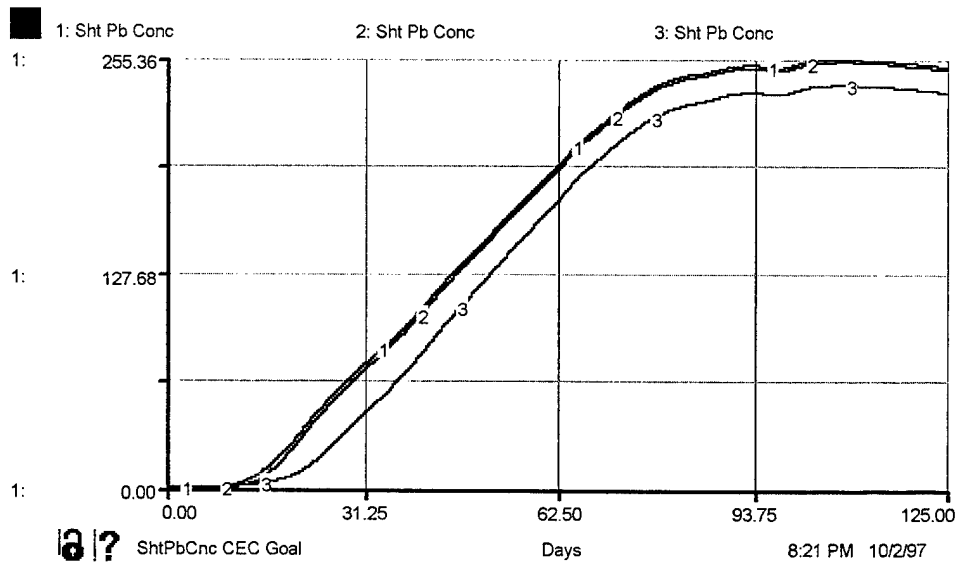

Figure 53 – Shoot concentration varying xylem CEC goal

Xylem CEC Factors – The shape of the graphs were not changed, but the maximum value for retardation was varied from 0.5 to 0.8 (baseline) to 1.0.

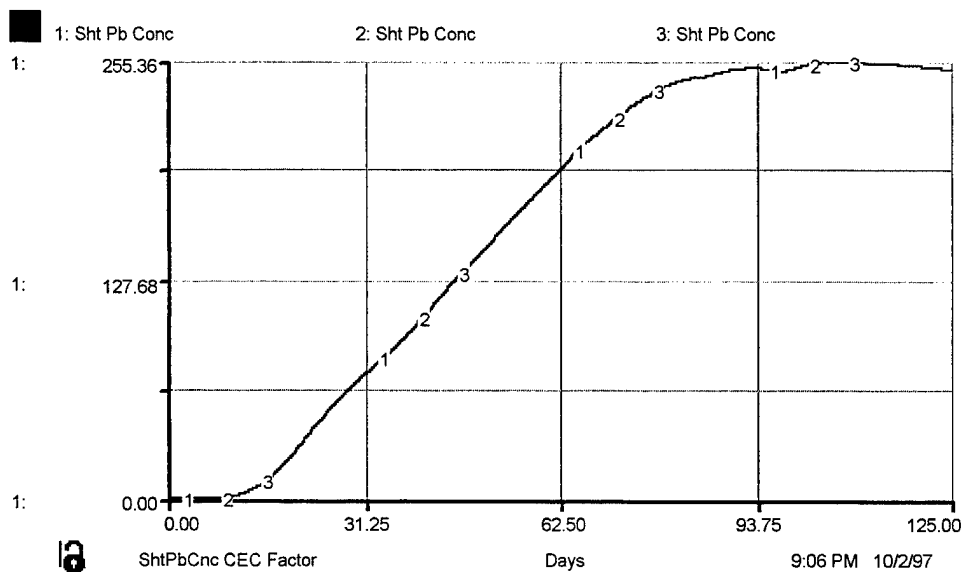

Figure 54 – Shoot concentration varying root and stem xylem CEC factors

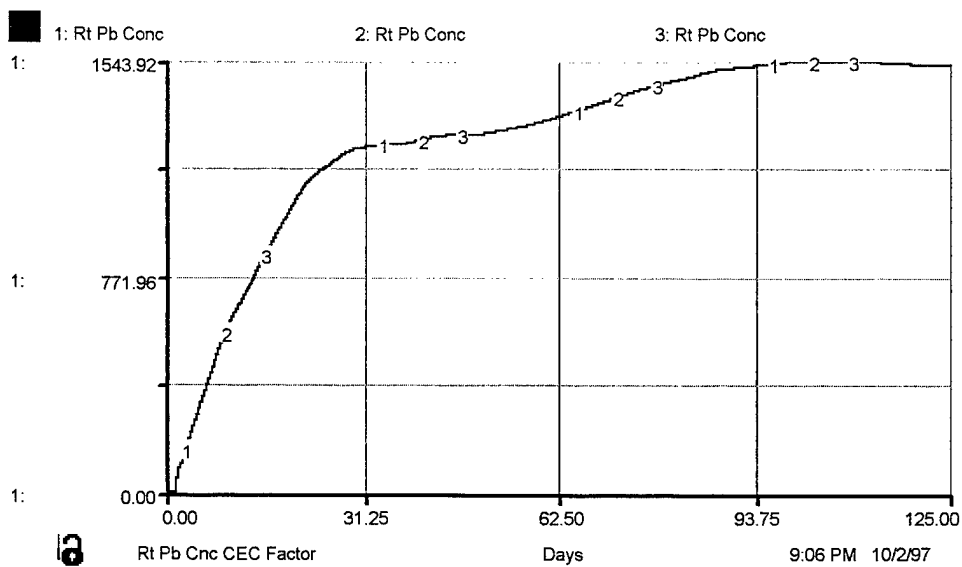

Figure 55 – Root concentration varying root and stem xylem CEC factors

Xylem Fraction – Varied simultaneously in the stem (0.2-trace 1, 0.1- trace 2, 0.04-trace 3), ear (0.1, 0.04, 0.005), leaf, and root (both 0.18, 0.08, 0.02).

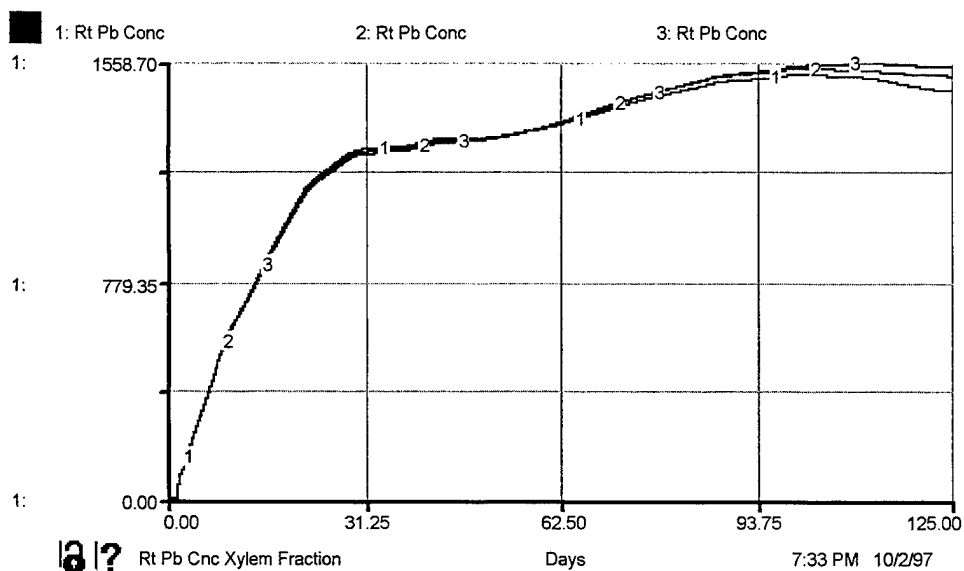

Figure 56 – Root concentrations varying xylem fractions

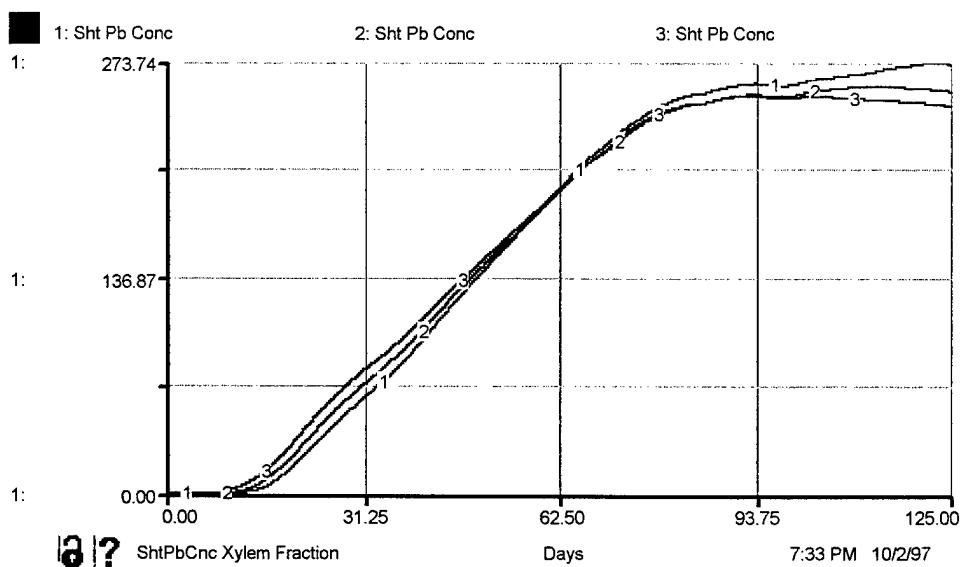

Figure 57 – Shoot concentrations varying xylem fractions

Phloem Fraction – Varied simultaneously in the ear (0.2-trace 1, 0.1- trace 2, 0.04-trace 3), stem, leaf, and root (all 0.18, 0.08, 0.02).

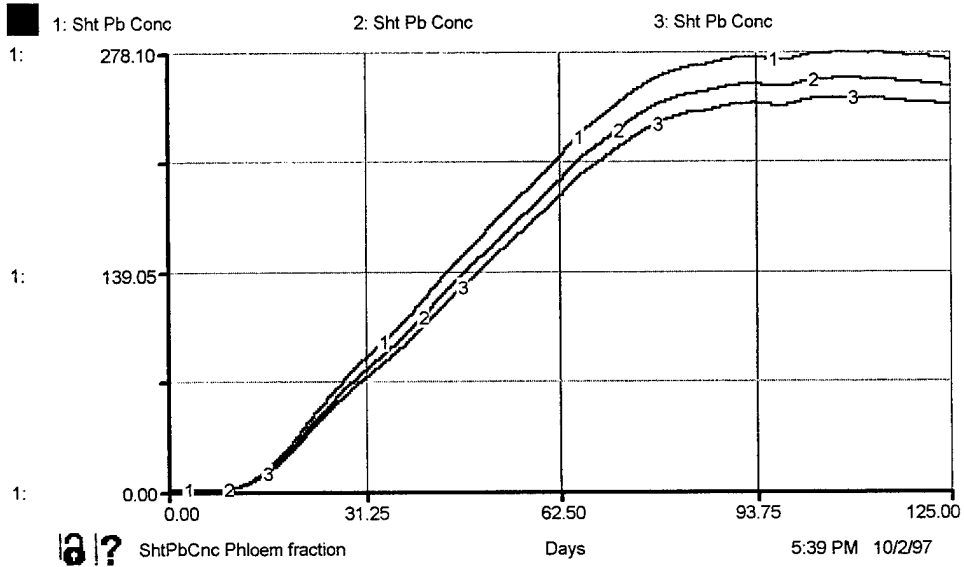

Figure 58 – Shoot concentrations varying phloem fractions

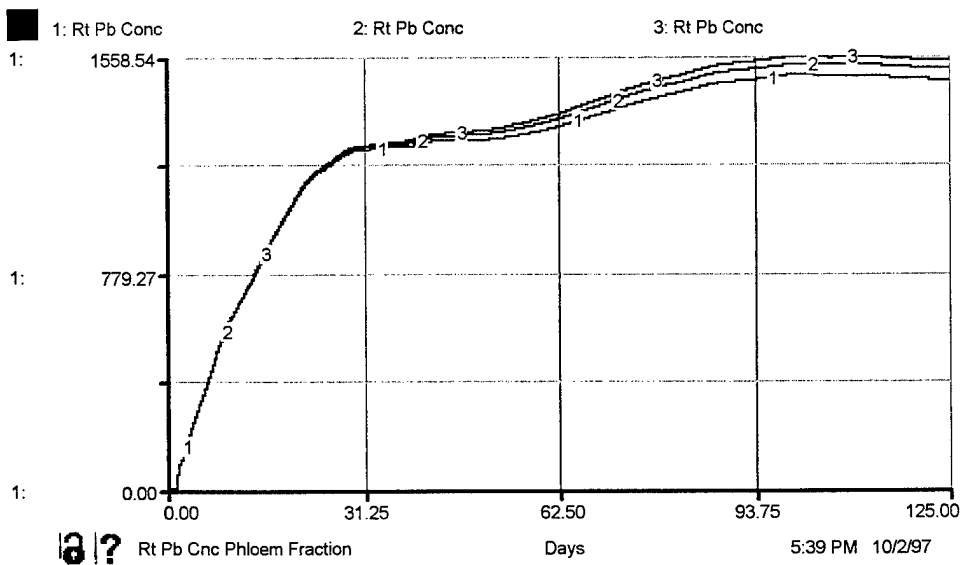

Figure 59 – Root concentrations varying phloem fractions

Stem Xylem Flow Transpiration Factors (Ear Tsp, Stm Tsp, and Lf Tsp graphs in model)
 – Varied from: baseline values (trace 1); 0-0.1 (min-max) in ear, 0.7-0.9 in leaf, and 0.1-0.2 in the stem (trace 2); 0-0.01 in ear, 0.8-0.95 in leaf, and 0.05 to 0.19 in stem (trace 3).
 The shape of all curves were maintained in the graphs.

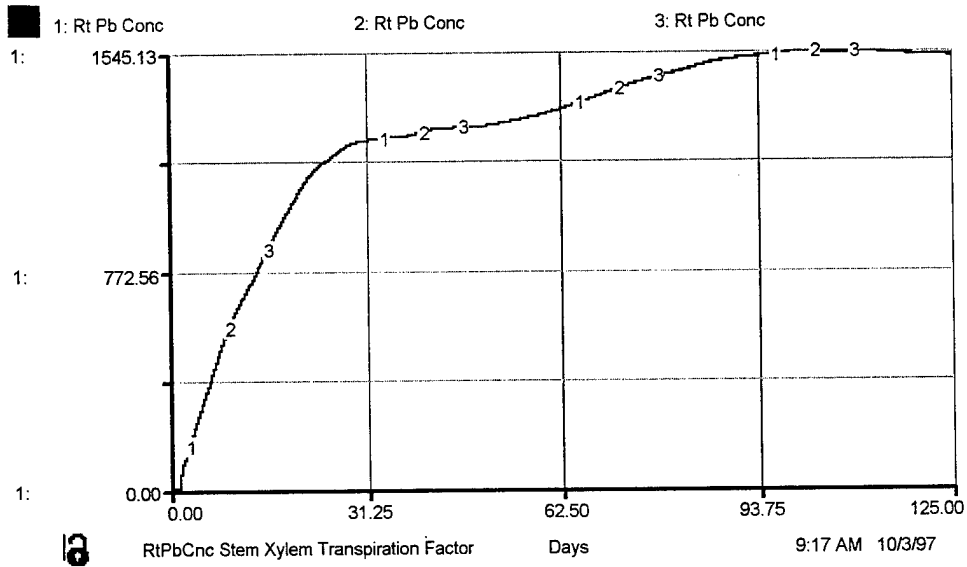

Figure 60 – Root concentrations varying stem xylem flow transpiration factors

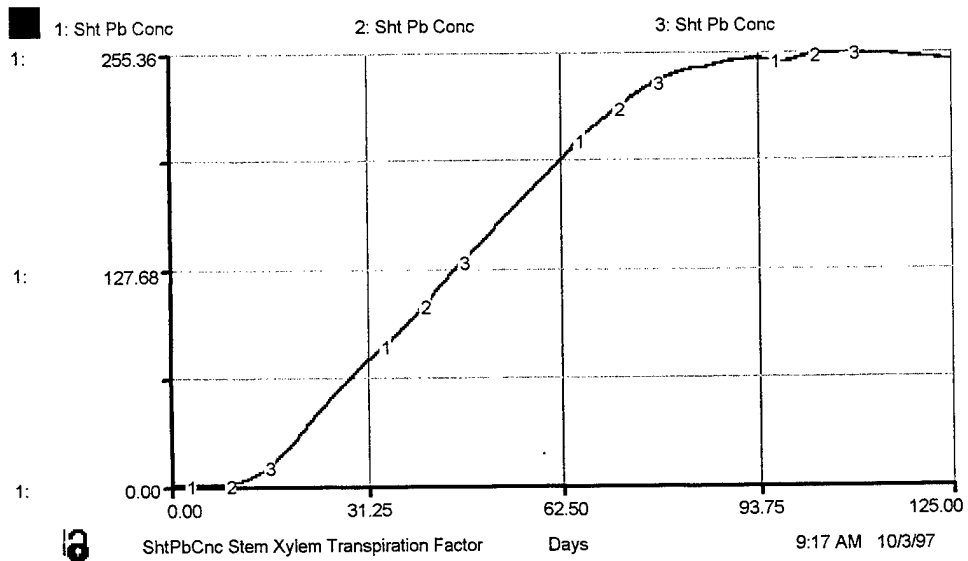

Figure 61 – Shoot concentrations varying stem xylem transpiration factors

Xylem-Phloem Transfer Fractions – Varied by one order of magnitude above (trace 3) and below (trace 1) the baseline (trace 2) value.

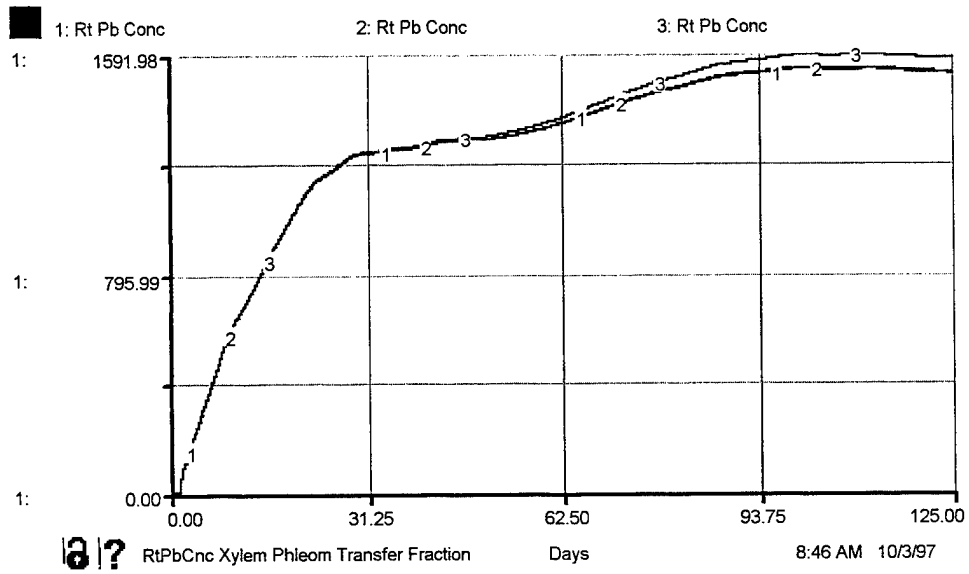

Figure 62 – Root concentrations varying xylem-phloem transfer fractions

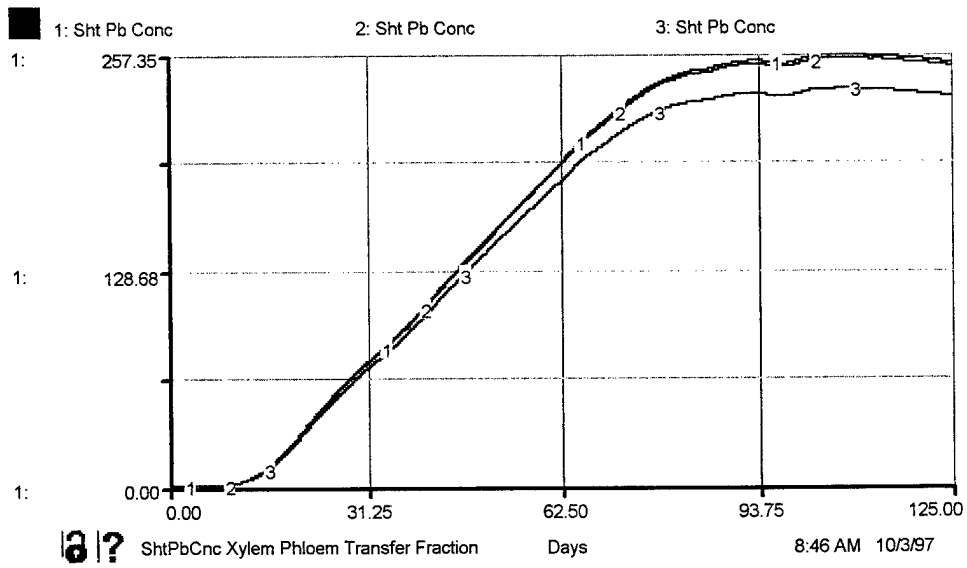

Figure 63 – Shoot concentrations varying xylem-phloem transfer fractions

Maximum Phloem Flow Rate - Varied from 0.05 (trace 1) to 0.15 (trace 2-baseline) to 0.40 (trace 3).

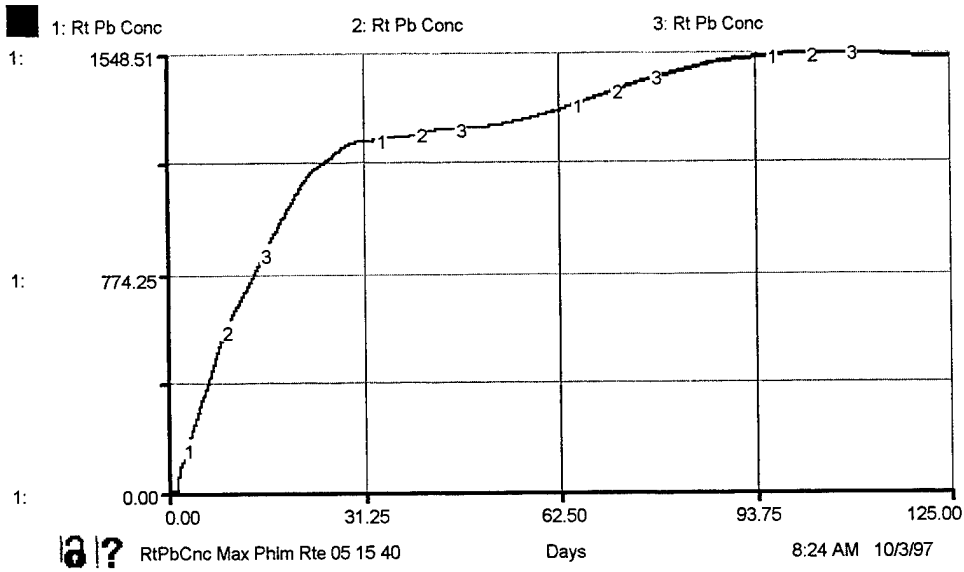

Figure 64 – Root concentrations varying maximum phloem flow rate

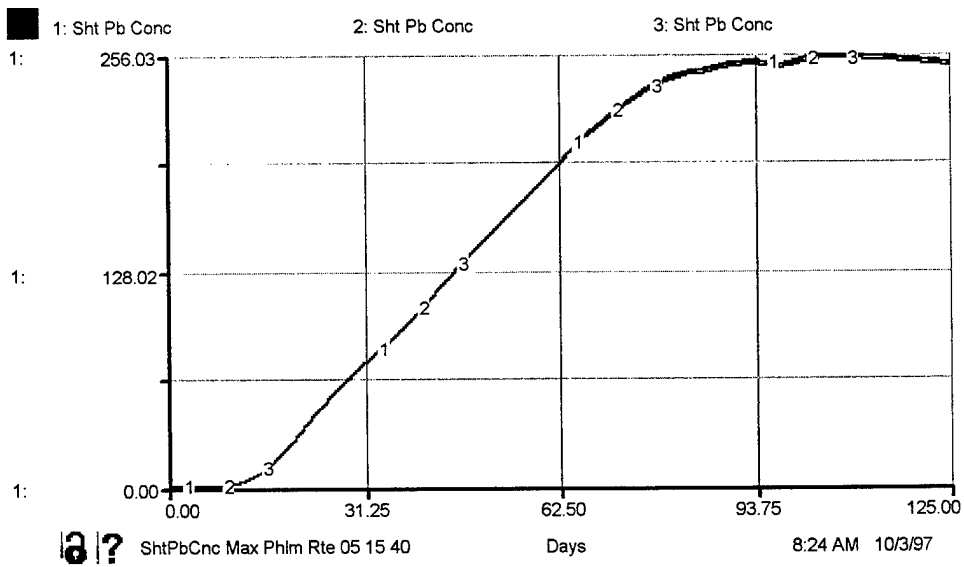

Figure 65 – Shoot concentrations varying maximum phloem flow rate

Plant Mass Fractions – Varied from final values of: ear mass 0.45 (trace 1), baseline (trace 2), 0.65 (trace 3); leaf mass 0.25, baseline, 0.15; and stem mass 0.30, baseline, 0.20. The shape of the curves were basically unchanged.

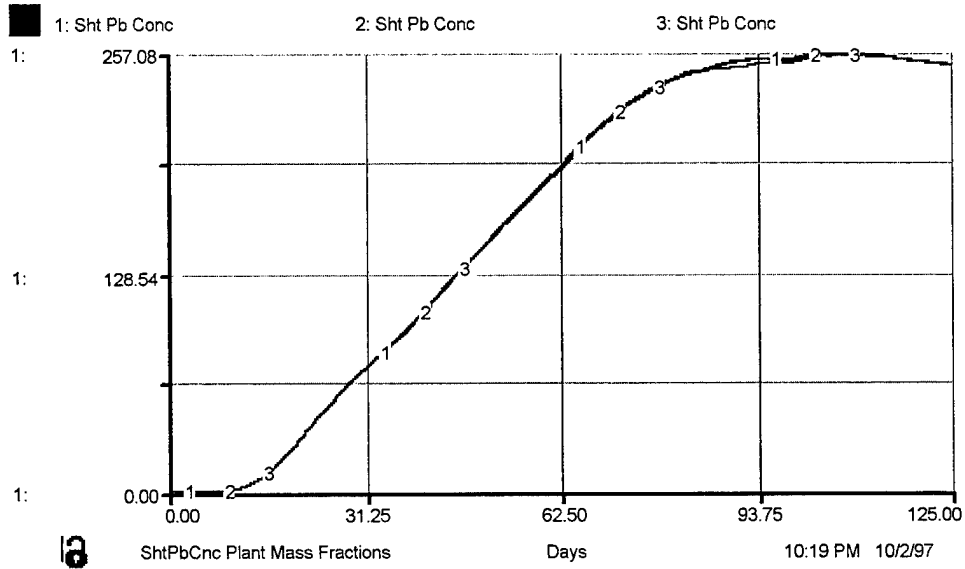

Figure 66 – Shoot concentrations varying plant mass fractions

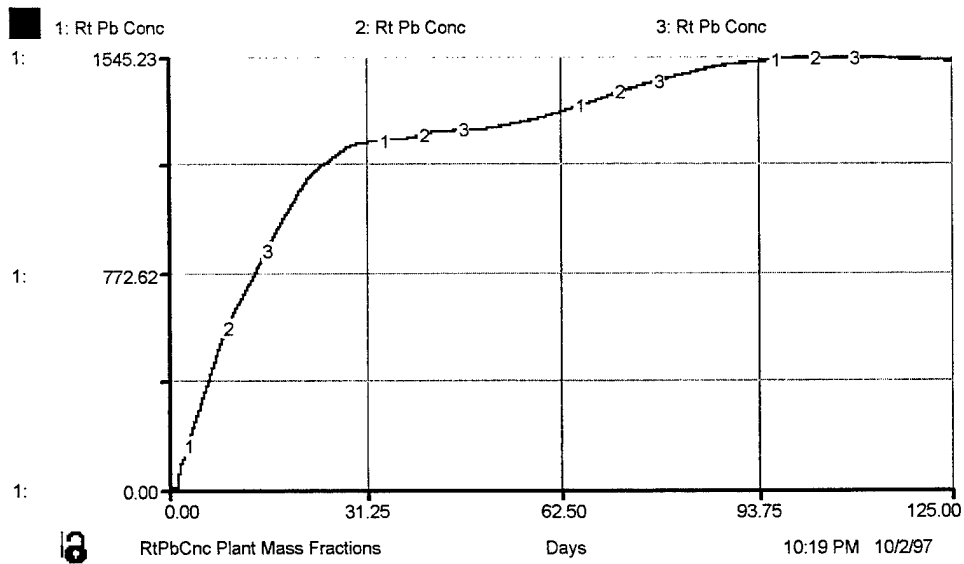

Figure 67 – Root concentrations varying plant mass fractions

Maximum Shoot Dry Mass – Varied from 0.25 (trace 1), to baseline (0.374, trace 2), to 0.5 (trace 3) maintaining the same basic shape of the growth curve.

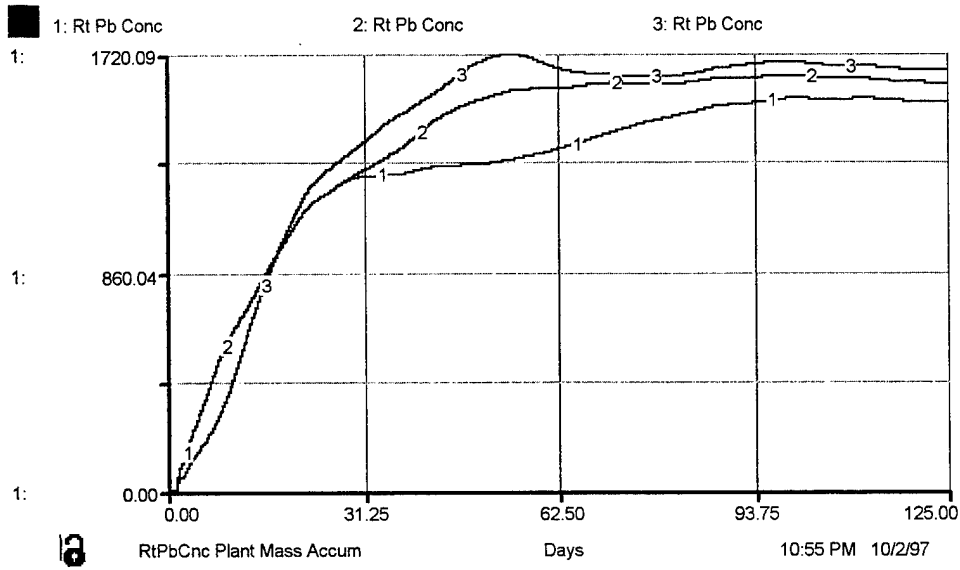

Figure 68 – Root concentrations varying maximum shoot dry mass

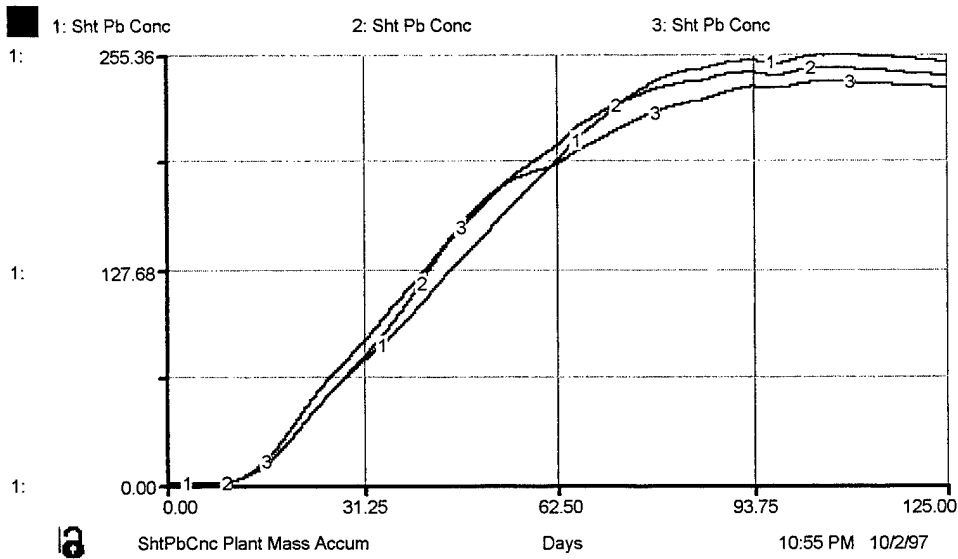

Figure 69 – Shoot concentrations varying maximum shoot dry mass

Shoot and Root Water Fractions (graph) – Varied from baseline (trace 1), to (max-min) 0.95-0.65 (trace 2), and 0.95-0.5 (trace 3) in both the root and shoot. The shape of the graph was maintained.

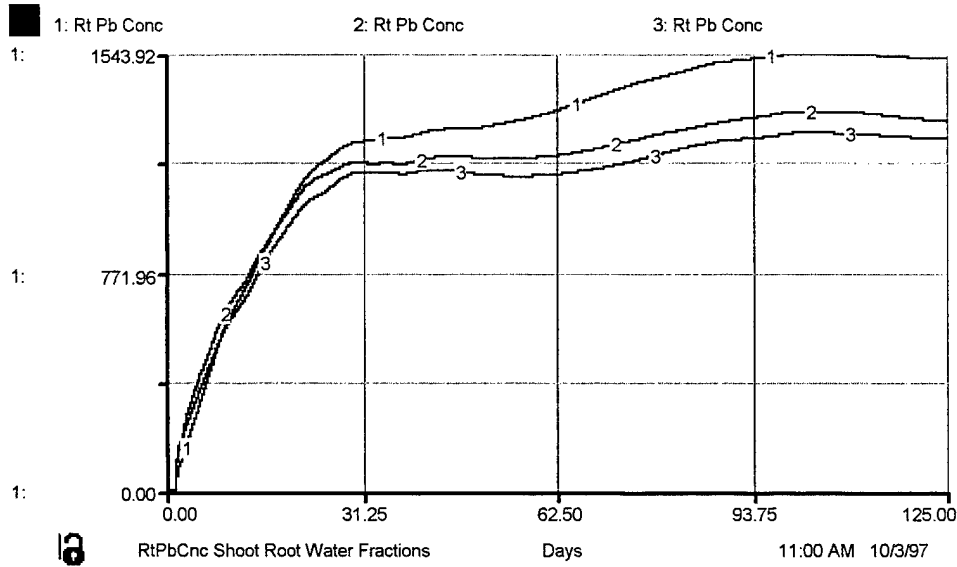

Figure 70 – Root concentration varying root and shoot water fractions

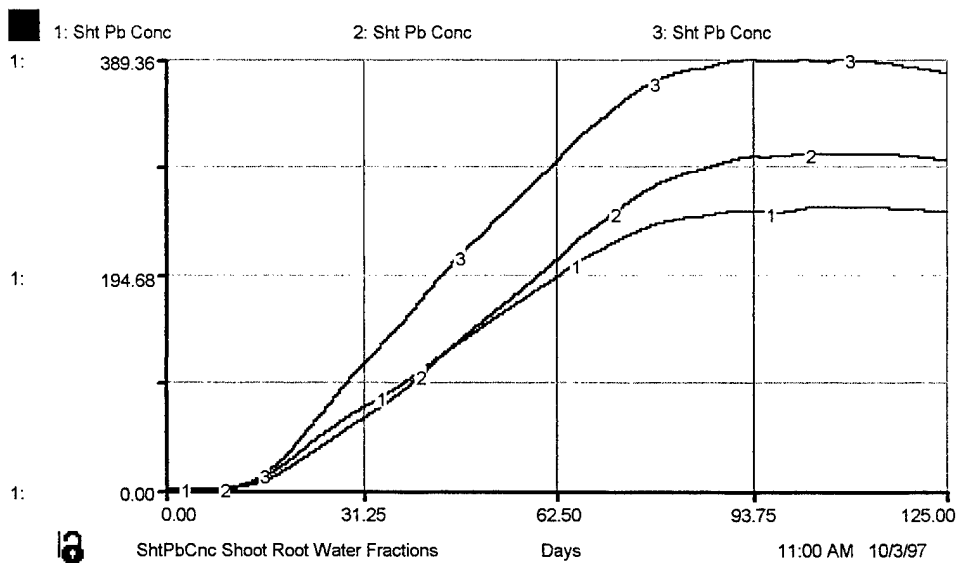

Figure 71 – Shoot concentrations varying shoot and root water fractions

Shoot to Root Ratios (Graph) – Varied from the baseline (trace 1), to (min-max) 0.5-4.0 using the same shape of graph (trace 2), and maintaining a constant ratio of 3.0 throughout the growing season (trace 3).

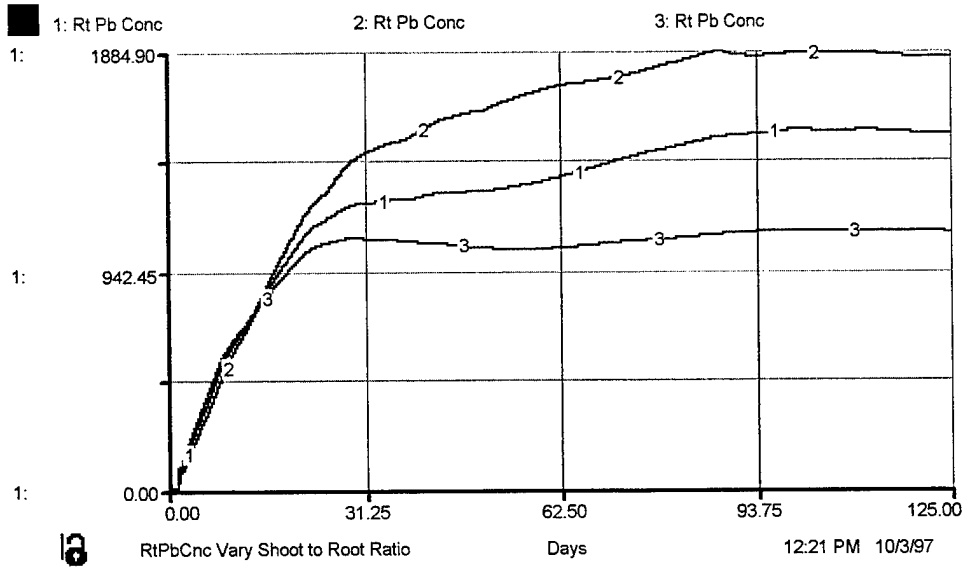

Figure 72 – Root concentrations varying shoot to root ratios

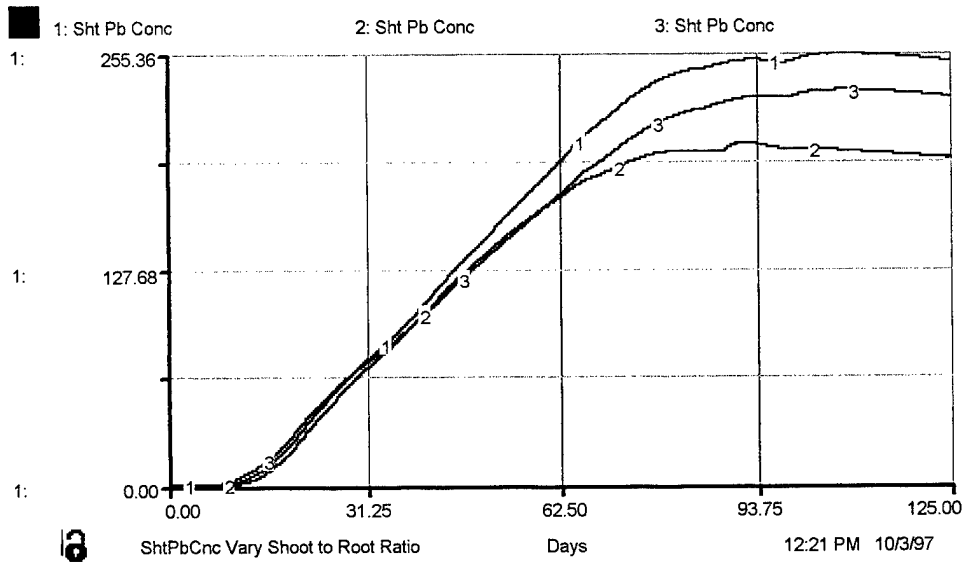

Figure 73 – Shoot concentrations varying shoot to root ratios

Transpiration Production and Maintenance Factors – Varied by changing the shape of the curve. Baseline-sigmoidal (trace 1), linear (trace 2), strongly accentuated-sigmoidal

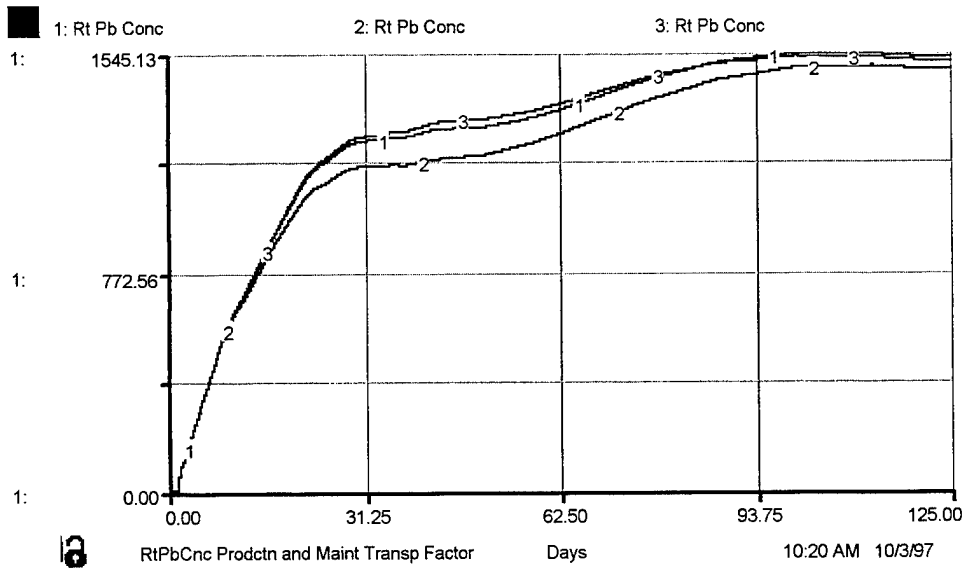

Figure 74 – Root concentration varying production/maintenance transpiration factors

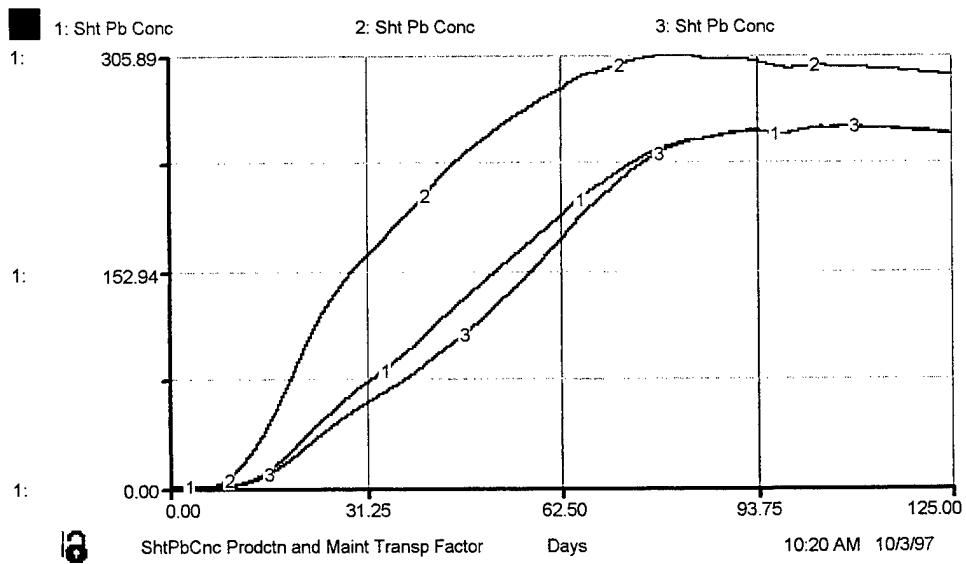

Figure 75 – Shoot concentration varying production/maintenance transpiration factors

Transpiration Coefficient – Varied from 250 to 349 (baseline) to 500.

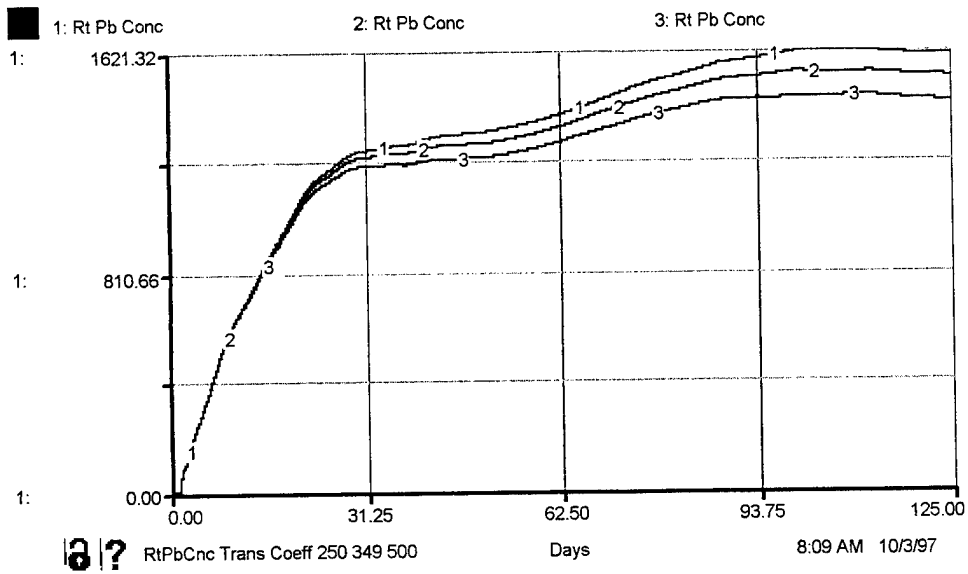

Figure 76 – Root concentration varying transpiration coefficient

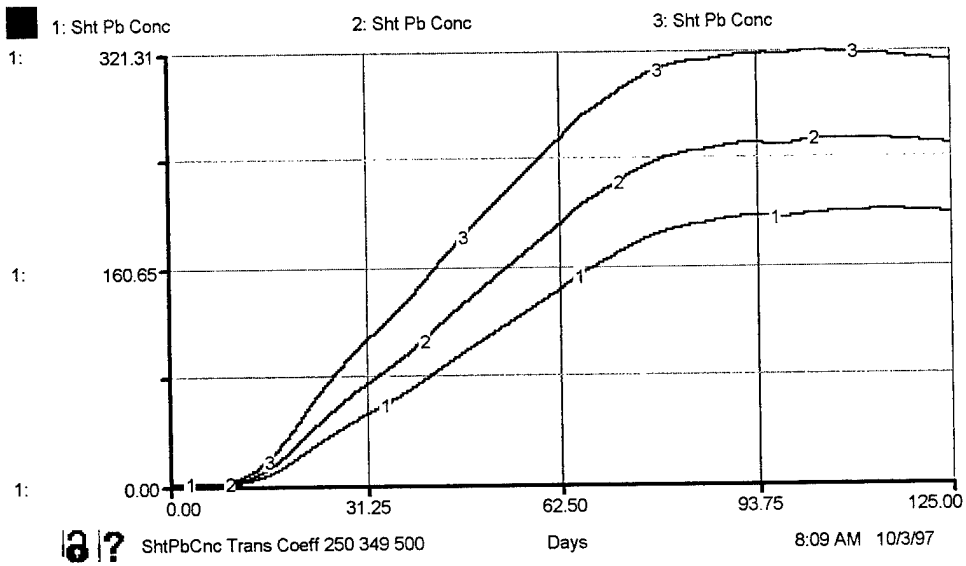

Figure 77 – Shoot concentrations varying transpiration coefficient

Bibliography

- Alloway, B.J. "Soil Processes and the Behaviour of Metals," in Heavy Metals in Soils. Ed. B.J. Alloway. New York: Blackie and Son, Ltd., 1990.
- Arnalk, P., S.A. Wasay, and S. Tokunaga. "A Comparative Study of Cd, Cr (III), Hg, and Pb Uptake by Minerals and Soil Materials," Water, Air, and Soil Pollution, 87: 131-148 (1996).
- Baker, A.J.M., S.P. McGrath, C.M.D. Sidoli, and R.D. Reeves. "The possibility of in situ heavy metal decontamination of polluted soils using crops of metal-accumulating plants," Resources, Conservation, and Recycling, 11: 41-49 (1994).
- Barber, S.A. and N. Claasen. "A Mathematical Model to Simulate Metal Uptake by Plants Growing in Soil," Proceedings of the Fifteenth Annual Hanford Life Sciences Symposium. 358-364. Richland, WA: Batelle, Pacific Northwest Laboratories, 1975.
- Baumhardt, G.R. and L.F. Welch. "Lead Uptake and Corn Growth with Soil-Applied Lead," Journal Of Environmental Quality, 1: 92-94 (1972).
- Bell, J.A. and J.F. Bell. "System Dynamics and Scientific Method," in Elements of the System Dynamics Method. Ed. J. Randers. Cambridge MA: Productivity Press, 1980.
- Berti, W.R., S.D. Cunningham, and L.W. Jacobs. "Sequential Extracton of Trace Elements: Development and Use in Remediating Contaminated Soils," Proceedings of the Third International Conference on the Biogeochemistry of Trace Elements. 1-10. Institute National de la Recherche Agronomique, France, 1996.
- Blaylock, M.J. Research Scientist, Phytotech, Inc., Monmouth Junction NJ. Personal Correspondence. 6 August 1997.
- Blaylock. M.J., D.E. Salt, S. Dushenkov, O. Zakharova, C. Gussman, Y. Kapulnik, B.D. Ensley, and I. Raskin. "Enhanced Accumulation of Pb in Indian Mustard by Soil-Applied Chelating Agents," Environmental Science and Technology, 37: 860-865 (1997).
- Bleckmann, C. A. Associate Professor of Engineering and Environmental Management, Air Force Institute of Technology, WPAFB OH. Personal Correspondence. 24 September 1997.

- Broyer, T.C., C.M. Johnson, and R.E. Paul. "Some Aspects of Lead in Plant Nutrition," Plant and Soil, 36: 301-313 (1972).
- Chlopecka, A. "Forms of Cd, Cu, Pb, and Zn in Soil and their Uptake by Cereal Crops when Applied Jointly as Carbonates," Water, Air, and Soil Pollution, 87: 297-309 (1996).
- Clarkson, D.T, and U. Luttge. "Mineral Nutrition: Divalent Cations, Transport and Compartmentalization," Progress in Botany, 51: 93-112 (1989).
- Cory, R.B., R. Fuji, and L.L. Hendrickson. "Bioavailability of Heavy Metals in Soil-Sludge Systems," Fourth Annual Madison Conference of Applied Research and Practice on Municipal and Industrial Waste. 449-466. Madison WI: Department of Engineering and Applied Science, University of Wisconsin Extension, 1981.
- Crowdy, S.H. and T.W. Tanton. "Water Pathways in Higher Plants," Journal of Experimental Botany, 21: 102-111 (1970).
- Cunningham, S. D. And Ow, D. W. "Promises and Prospects of Phytoremediation," Plant Physiology, 110: 715-719 (1996).
- Cunningham, S. D., J. R. Shann, D. Crowley, and T. A. Anderson. "Phytoremediation of Contaminated Water and Soil", in Phytoremediation of Soil and Water Contaminants. Ed. E.L. Krueger, T. A. Anderson, and J. P. Coats, Washington D.C.: American Chemical Society, (in press) 1997.
- Cunningham, S. D., W. R. Berti, and J. W. Huang. "Remediation of Contaminated Soils and Sludges by Green Plants," in Bioremediation of Inorganics Ed. R. E Hinchee, J. L. Means, and D. R. Burris. Columbus, OH: Batelle Press, 33-54, 1995.
- Cunningham, S.D. Dupont Central Research and Development, Newark DE. Personal Correspondence. 27 May 1997.
- Cunningham, S.D. Dupont Central Research and Development, Newark DE. Personal Correspondence. 5 September 1997
- Davies, B.E. "Lead," in Heavy Metals in Soils Ed. B.J. Alloway. 177-196. New York: Blackie and Sons, Ltd., 1990.
- Davies, B.E. and L.H.P Jones. "Micronutrients and Toxic Elements," in Russell's Soil Conditions and Plant Growth. Ed. A. Wild. New York: John Wiley and Sons, 780-815, 1988.

- Dushenkov, V., P.B.A. N Kumar, H. Motto, and I. Raskin. "Rhizofiltration: The Use of Plants to Remove Heavy Metals from Aqueous Streams," Environmental Science and Technology, 29: 1239-1245 (1995).
- Ernst, W.H.O. "Bioavailability of Heavy Metals and Decontamination of Soils by Plants," Applied Geochemistry, 11: 163-167 (1996).
- Fahn, A. Plant Anatomy (Fourth Edition). New York: Pergamon Press, Inc., 1990.
- Farago, M.E. "Metal Tolerant Plants," Chemtech: 684-687 (November 1981).
- Forbes, J.C. and R.D. Watson. Plants in Agriculture. New York: Cambridge University Press, 1992.
- Forrester, J.W and P.M. Senge. "Tests for Building Confidence in System Dynamics Models," TIMS Studies in the Management Sciences, 14: 209-228 (1980).
- Foy, C.D., R.L. Chaney, and M.C. White. "The Physiology of Metal Toxicity in Plants," in Annual Review of Plant Physiology. Ed. W.R. Briggs, P.B. Green, and R.L. Jones. Palo Alto CA: Annual Reviews, Inc., 1978.
- Gavloski, J.E., G.H. Whitfield, and C.R. Ellis. "Effect of Restricted Watering on Sap Flow and Growth in Corn (*Zea mays* L.)," Canadian Journal of Plant Science, 72: 361-368 (1992).
- Gardner, F.P., R.B. Pearce, and R.L. Mitchell. Physiology of Crop Plants. Ames, IA: The Iowa State University Press, 1985.
- Gerritse, R.G., W.V. Driel, K.W. Smilde, and B.V. Luit. "Uptake of Heavy Metals by Crops in Relation to their Concentration in Soil Solution," Plant and Soil, 75: 393-404 (1983).
- Glass, A.D.M. Plant Nutrition, An Introduction to Current Concepts. Boston: Jones and Bartlett Publishers, 1989.
- Gregory, P.J. "Growth and Functioning of Plant Roots," in Russell's Soil Conditions and Plant Growth (Eleventh Edition). Ed. A. Wild. New York: John Wiley and Sons, Inc., 1988.
- Haque, A. and V. Subramanian. "Copper, Lead, and Zinc Pollution of Soil Environment," Critical Reviews in Environmental Control, 12: 13-69 (1982).
- Hanway, J.J. How a Corn Plant Develops, Special Report Number 48, Iowa State University of Science and Technology Cooperative Extension Service. Ames IA: Iowa State University of Science and Technology, 1966.

- Hanway, J.J. and W.A. Russell. "Dry Matter Accumulation in Corn (*Zea mays* L.) Plant Comparisons Among Single Cross Hybrids," Agronomy Journal, 61: 947-951 (1969).
- Hassett, J.J., J.E. Miller, and D.E. Koeppel. "Interaction of Lead and Cadmium on Maize Root Growth and Uptake of Lead and Cadmium by Roots," Environmental Pollution, 11: 297-302 (1976).
- Hartmann, H.T., A.M. Kofranek, V.E. Rubatzky, and W.J. Flocker. Plant Science. Englewood Cliffs, NJ: Prentice Hall, Inc., 1988.
- Huang, J.W. Research Scientist, Phytotech Inc., Monmouth Junction NJ. Personal Correspondence. 3 August 1997.
- Huang, J. W., J. Chen, W. R. Berti, and S. D. Cunningham. "Phytoremediation of Lead-Contaminated Soils: Role of Synthetic Chelates in Lead Phytoextraction," Environmental Science and Technology, 31: 800-805 (1997).
- Huang, J. W., S.D. Cunningham, and S.J. Germani. "Plant Based Soil Remediation: preliminary Study of Pb Phytoextraction from Pb-contaminated Soils," Proceedings of the 3rd International Conference of Biogeochemistry, France, (1996).
- Huang, J. W. And Cunningham, S. D. "Lead Phytoextraction: Species Variation in Lead Uptake and Translocation," New Phytologist, 134:1-6 (1996).
- Hughes, M.K., N.W. Lepp, and D.A. Phipps. "Aerial Heavy Metal Pollution and Terrestrial Ecosystems," in Advances in Ecological Research (Volume 11). Ed. A. MacFadyen. New York: Academic Press, Inc., 1980.
- Jones, L.H.P., S.C. Jarvis, and D.W. Cowling. "Lead Uptake From Soils By Perennial Ryegrass and its Relation to the Supply of an Essential Element," Plant and Soil, 38: 605-619 (1973).
- Jones, C.A. and J.R. Kiniry. CERES-Maize, A Simulation Model of Maize Growth and Development. College Station TX: Texas A&M University Press, 1986.
- Jorgensen, S.E. "Removal of Heavy Metals from Compost and Soil by Ecotechnological Methods," Ecological Engineering, 2: 89-100 (1993).
- Kabata-Pendias, Alina and Henryk Pendias. Trace Elements in Soils and Plants. Boca Raton: CRC Press, Inc., 1992.

- Kinnersley, A.M. "The Role of Phytochelates in Plant Growth and Productivity," Plant Growth Regulation, 12: 207-218 (1993).
- Kochian, L.V. "Mechanisms of Micronutrient uptake and Translocation in Plants," in Micronutrients in Agriculture, Second Edition. Ed. J.J. Mordtvedt and others. Madison, WI: Soil Science Society of America, Inc., 1991.
- Koepe, D.E. "The Uptake, Distribution, and Effect of Cadmium and Lead in Plants," The Science of the Total Environment, 7: 197-206 (1977).
- Kramer, P.J. and J.S. Boyer. Water Relations in Plants and Soils. San Diego: Academic Press, 1995.
- Kumar, P.B.A. Nanda, Viatcheslav Dushenkov, Harry Motto, and Ilya Raskin. "Phytoextraction: The Use of Plants to Remove Heavy Metals from Soils", Environmental Science and Technology, 29: 1232-1238 (1995).
- Lauchli, A. and R.L. Bielski. Inorganic Plant Nutrition. New York: Springer-Verlag, 1983.
- Legasto Jr., A. and J. Maciariello. "System Dynamics: A Critical Review," TIMS Studies in the Management Sciences, 14: 23-43 (1980).
- Lindsay, W.L. Chemical Equilibria in Soils. New York: John Wiley and Sons, 1979.
- Lindstrom, F.T., L. Boersma, and C. MacFarlane. "Mathematical Model of Plant Translocation of Organic Chemicals; Development of the Model," Journal of Environmental Quality, 20: 129-136 (1991).
- Loneragan, J.F. "The Availability and Absorption of Trace Elements in Soil-Plant Systems and Their Relation to Movement and Concentration of Trace Elements in Plants," in Trace Elements in Soil-Plant-Animal Systems. Ed. D.J.D. Nicholas and A.R. Egan. New York: Academic Press, Inc., 1975.
- Malone, C., D.E. Koepe, and R.J. Miller. "Localization of Lead Accumulated in Corn Plants," Plant Physiology, 53: 388-394 (1974).
- Marschner, H. Mineral Nutrition of Higher Plants. Orlando: Academic Press, Inc., 1986.
- Marschner, H. "General Introduction to the Mineral Nutrition of Plants," in Encyclopedia of Plant Physiology, Volume 15A, Inorganic Plant Nutrition. Ed. A. Lauchli and R.L. Bielecki. New York: Springer-Verlag, 1983.
- McBride, M.B. Environmental Chemistry of Soils. New York: Oxford University Press, 1994.

- Meadows, D.H. "The Unavoidable 'A Priori'," in Elements of the System Dynamics Method. Ed. J. Randers. Cambridge MA: Productivity Press, 1980.
- Mengel, K. and E.A. Kirkby. Principles of Plant Nutrition. Bern: International Potash Institute, 1987.
- Milburn, J.A. Water Flow in Plants. London: Longman Group Limited, 1979.
- Miller, J.E., J.J. Hassett, and D.E. Koeppel. "Interactions of Lead and Cadmium on Metal Uptake and Growth of Corn Plants," Journal of Environmental Quality, 6: 18-20 (1977).
- Morel, M.M.F. and J.G. Hering, Principles and Applications of Aquatic Chemistry. New York: John Wiley & Sons, Inc., 1993.
- Newlin, J.J., E. Anderson, and E.N. Bressman. Corn and Corn Growing. New York: John Wiley and Sons, Inc., 1949.
- Nissen, P. "Multiphasic Ion Uptake in Roots," in Ion Transport in Plants. Ed. W.P. Anderson, W.P. New York: Academic Press, Inc., 1973.
- Nissen, P. "Uptake Mechanisms," in Plant Roots, The Hidden Half (Second Edition). Ed. Y. Waisel, A. Eshel, and U. Kafkafi. New York: Marcel Dekker, Inc., 1996.
- Nobel, P. S. Physicochemical and Environmental Plant Physiology. San Diego: Academic Press, Inc., 1991.
- Peake, M.B. Modeling Plant Uptake of Metal in Constructed Wetlands Supported by Experimentally Derived Uptake Rates. MS thesis, AFIT/GEE/ENV/96D-15. School of Engineering, Air Force Institute of Technology (AU), Wright-Patterson AFB OH, December 1996.
- Peterson, S. and B. Richmond. Stella II Technical Documentation. Hanover NH: High Performance Systems, 1994.
- Pitman, M.G. and Cram, W.J. "Regulation of Inorganic Ion Transport in Plants," in Ion Transport in Plants. Ed. W.P. Anderson. New York: Academic Press Inc., 1973.
- Randers, J. "Guideline for Model Conceptualization," in Elements of the System Dynamics Method. Ed. J. Randers. Cambridge MA: Productivity Press, 1980.
- Rao, S. and S. Mathur. "Modeling Heavy Metal (Cadmium) Uptake by Soil-Plant Root System," Journal Of Irrigation and Drainage Engineering, 120: 89-97 (1994).

- Raskin, I., N.P.B.A. Kumar, S. Dushenkov, and D.E. Salt. "Bioconcentration of Heavy Metals by Plants," Current Opinions in Biotechnology, 1994: 285-290 (1994).
- Rengel, Z. "Mechanistic Simulations Models of Nutrient Uptake: A Review," Plant and Soil, 152: 161-173 (1993).
- Ritchie, J.T. "Influence of Soil Water Status and Meterological Conditions on Evaporation from a Corn Canopy," Agronomy Journal, 65: 893-897 (1973).
- Ritchie, S.W., J.J. Hanway, and G.O. Benson. How a Corn Plant Develops, Special Report Number 48. Iowa State University of Science and Technology, Cooperative Extension Service, WWWeb, <http://www.ag.edu.departments/agronomy/corntitle.html> (15 June 1997).
- Roberts, N. and others. Introduction to Computer Simulation: A System Dynamics Approach. Addison Wesley, 1983.
- Robinson, D. "Roots and Resource Fluxes in Plants and Communities," in Plant Root Growth, an Ecological Perspective. Ed. D. Atkinson. Oxford: Blackwell Scientific Publications, 1991.
- Salisbury, F.B. and C.W. Ross. Plant Physiology. Belmont CA: Wadsworth Publishing Company, 1992.
- Salt, D.E., M. Blaylock, N. P. B. A. Kumar, V. Dushenkov, B. D. Ensley, I. Chen, and I. Raskin. "Phytoremediation: A Novel Strategy for the Removal of Toxic Metals from the Environment Using Plants," Biotechnology, 13: 468-474 (1995).
- Salt, D.E. Research Assistant Professor, Rutgers University, New Brunswick NJ. Personal Correspondence. 14 Aug 1997.
- Salvador, R. Associate Professor of Agronomy, Iowa State University, Ames IA. Personal Correspondence. 28 May 1997.
- Senden, M.H.M.N., F.J.M. Van Paasen, A.J.G.M. Van Der Meer, and H.T.H. Wolterbeek. "Cadmium-Citric Acid-Xylem Cell Wall Interactions in Tomato Plants," Plant Cell and Environment, 15: 71-79 (1992).
- Shelley, M.L. Class handout, ENVR 642, Environmental System Dynamics Modeling. School of Engineering, Air Force Institute of Technology, Wright-Patterson AFB OH, February 1997.
- Shelley, M.L. Class handout, ENVR 642, Environmental System Dynamics Modeling. School of Engineering, Air Force Institute of Technology, Wright-Patterson AFB OH, January 1997.

- Silberbush, M. "Simulation of Ion Uptake from the Soil," in Plant Roots, The Hidden Half (Second Edition). Ed. Y. Waisel, A. Eshel, and U. Kafkafi. New York: Marcel Dekker, Inc., 1996.
- Stephan, U.W. and G. Scholz. "Nicotianamine: Mediator of Iron and Heavy Metals in the Phloem?" Physiologia Planta, 88: 522-529 (1993).
- Sterman, J.D. "A Skeptic's Guide to Computer Models," in Modelling for Management, Volume I. Ed. G.P. Richardson. Brookfield VT: Dartmouth Publishing Company, 1996.
- Tiffin, L.O. "The Form and Distribution of Metals in Plants," in Biological Implications of Metals in the Environment, Proceedings of the Fifteenth Annual Hanford Life Sciences Symposium. Chairmen, H. Drucker and R.E. Wildung. Springfield, VA: Technical Information Center, Energy Research and Development Administration, October 1975.
- Tyler, G. A.M. Balsberg Pahlsson, G. Bengtsson, E. Baath, and L. Tranvik. "Heavy-Metal Ecology of Terrestrial Plants, Microorganisms, and Invertebrates," Water, Air, and Soil Pollution, 47. 189-215 (1989).
- University of Illinois. An Interdisciplinary Study of Environmental Pollution by Lead and Other Metals; Progress Report to the National Science Foundation. Urbana-Champaign IL: Environmental Studies Program, Graduate College, University of Illinois, 1972.
- Walker, C. H., S. P. Hopkin, R. M. Sibly, and D. B. Peakall. Principles of Ecotoxicology. Bristol, PA: Taylor and Francis, Inc., 1996.
- Wallace, A. "The Third Decade of Synthetic Chelating Agents in plant Nutrition 1952-1982, Part 1," Journal of Plant Nutrition, 6: 423-426 (1983).
- Watanabe, M. A. "Phytoremediation on the Brink of Commercialization," Environmental Science and Technology, 31 (4): 182A-186A (1997).
- Westgate, M.E. and Boyer, J.S. "Transpiration and Growth-Induced Water Potentials in Maize," Plant Physiology, 74: 882-889 (1983).
- Zimdahl, R.L. and D.e. Koepe. "Uptake by Plants," in Lead in the Environment. Ed. W.R. Boggess and B.G. Wixson. Washington DC: National Science Foundation, 1977.

Vita

Major Mark A. Brennan was born on [REDACTED]. He graduated from Walnut High School in Walnut, Illinois in 1980. He entered college at Illinois State University the same year and graduated with a Bachelor of Science Degree in Geology and Mathematics in May 1985. He entered Officer Candidate School on 9 June 1986 and received his commission of 15 August 1986 after successfully completing the school.

After completing six months training at The Basic School in Quantico, Virginia he was transferred to the Marine Corps Air Ground Combat Center in 29 Palms, California for his first assignment. He served as an engineer platoon commander and company executive officer during this assignment. His second assignment was at the Marine Corps Security Force Company in Charleston, South Carolina where he served as a guard officer. He was then transferred to Quantico, Virginia to attend the Amphibious Warfare School. Upon completion of this school he was transferred to the Third Marine Division in Okinawa, Japan. There he served as the Deputy Division Inspector and as a company commander for a combat engineer company and headquarters and service company. In May 1996 he entered the School of Engineering, Air Force Institute of Technology.

Permanent Address: [REDACTED]

REPORT DOCUMENTATION PAGE			Form Approved OMB No. 0704-0188	
Public reporting burden for this collection of information is estimated to average 1 hour per response, including the time for reviewing instructions, searching existing data sources, gathering and maintaining the data needed, and completing and reviewing the collection of information. Send comments regarding this burden estimate or any other aspect of this collection of information, including suggestions for reducing this burden, to Washington Headquarters Services, Directorate for Information Operations and Reports, 1215 Jefferson Davis Highway, Suite 1204, Arlington, VA 22202-4302, and to the Office of Management and Budget, Paperwork Reduction Project (0704-0188), Washington, DC 20503.				
1. AGENCY USE ONLY (Leave blank)	2. REPORT DATE December 1997	3. REPORT TYPE AND DATES COVERED Master's Thesis		
4. TITLE AND SUBTITLE MODELING THE UPTAKE AND TRANSLOCATION OF LEAD (PB) BY MAIZE FOR THE PURPOSES OF PHYTOEXTRACTION			5. FUNDING NUMBERS	
6. AUTHOR(S) MARK A. BRENNAN, Major, USMC				
7. PERFORMING ORGANIZATION NAME(S) AND ADDRESS(ES)			8. PERFORMING ORGANIZATION REPORT NUMBER AFIT/GEE/ENV/97D-02	
9. SPONSORING/MONITORING AGENCY NAME(S) AND ADDRESS(ES)			10. SPONSORING/MONITORING AGENCY REPORT NUMBER	
11. SUPPLEMENTARY NOTES				
12a. DISTRIBUTION AVAILABILITY STATEMENT Approved for public release; distribution unlimited			12b. DISTRIBUTION CODE	
13. ABSTRACT (Maximum 200 words) Phytoextraction is a remediation technology that uses plants to remove heavy metals from soil. This technology has the potential to decrease the costs of remediating contaminated sites by several orders of magnitude compared to traditional technologies. To effectively implement this technology requires an understanding of the plant processes that control uptake and translocation of metals from the soil. Currently these processes are poorly understood, and especially so for Pb. The purpose of this thesis was to gain insights concerning the plant mechanisms that control uptake and translocation of Pb and how these mechanisms interact to control levels of Pb accumulation in the plant. This was accomplished by developing, testing, and implementing a system dynamics model that simulated a maize plant taking up and translocating Pb. As a result of a rigorous process of conceptualization, formulation, and testing, it appears that this model is a valid tool for studying uptake, translocation, and accumulation of Pb. The results suggest that precipitation of Pb as a Pb-phosphate at the root surface and throughout the plant is one of the most important mechanisms in this system. The maximal uptake rate of Pb (Vmax) and effective root mass may also be key plant parameters in this process. The model may also be used to test various phytoextraction management scenarios, two of which were tested in this study.				
14. SUBJECT TERMS Uptake, Translocation, Maize, Modeling, Lead (Pb), Phytoextraction, System Dynamics, Plants			15. NUMBER OF PAGES 230	
			16. PRICE CODE	
17. SECURITY CLASSIFICATION OF REPORT Unclassified	18. SECURITY CLASSIFICATION OF THIS PAGE Unclassified	19. SECURITY CLASSIFICATION OF ABSTRACT Unclassified	20. LIMITATION OF ABSTRACT UL	