

Cross Shaft Design From the Aspect of Capacity

Lozica Ivanović¹⁾
Danica Josifović¹⁾
Katarina Živković¹⁾
Blaža Stojanović¹⁾

A cross shaft is one of the most important parts of the Cardan joint. In most cases, the size and lifetime of the Cardan joint depend on the cross shaft. To ensure the quality of mechanical parts, it is necessary to fulfill the basic constructional requirements related to the form, function, material and manufacturing procedure. The form of mechanical parts is the result of adjusting all of these requirements, and the task of a constructor is to develop forms with the aim of finding the best solution. This paper describes the procedure of determining the effect of geometry changes on the stress level in the cross shaft of the Cardan joint. The task of the Cardan joint is mechanical transmission of power and motion between shafts that change the position of their axes in the process of exploitation or are placed at a certain angle. The critical stress at the cross shaft was calculated by the analytical method and tested by a numerical solution. It is shown how small changes in the geometry of the cross shaft can lead to a significant reduction of critical stress. The most favorable ratio between the geometry of the cross shaft and the extreme stress values has been obtained by the means of the iterative correction of the form and the repetition of the numerical stress calculation.

Key words: cross shaft, critical stress, numerical methods, geometric shape, cardan joint.

Introduction

CARDAN joints are used to connect misaligned intersecting shafts. They transmit rotational motion from one shaft to another. Cardan joints, also referred to as either universal joints or Hooke joints, have been used for many years in mechanical devices such as automobiles and aircraft. These applications required small joint angles. Cardan joints can be used under high speed, large operating angle and heavy load conditions [1-4].

In the development of agricultural and transport mechanical engineering there is a rapid development of Cardan mechanisms and their increasing use. For mobile transportation and agricultural machines, in a motion subjected to significant shaking and change of position of some of their shafts, it was necessary to mount such a mechanism that does not react to changes in the position of the shaft axes, and thereby maintain good exploitation properties of the machine.

Cardan joints are used in transport and agricultural machinery, cars and locomotives, radio electronic devices, machine tools, drills and pumps of the oil industry, control mechanisms in aircraft and helicopters, timber industry, textile industry, etc. [4].

A correct placement of Cardan mechanisms, in terms of structural composition, gives to a designer a possibility of greater freedom in solving mutual arrangement of shaft transmitters. However, the use of Cardan joints in some cases leads to the creation of large dynamic loads (hydraulic transmissions, etc.).

A change in the cross shaft shape has been given as an example for improving the capacity of a construction.

Cross shaft

A cross shaft is one of the most important parts of the Cardan joint. In most cases, the size and lifetime of the Cardan joint depend on the cross shaft [4].

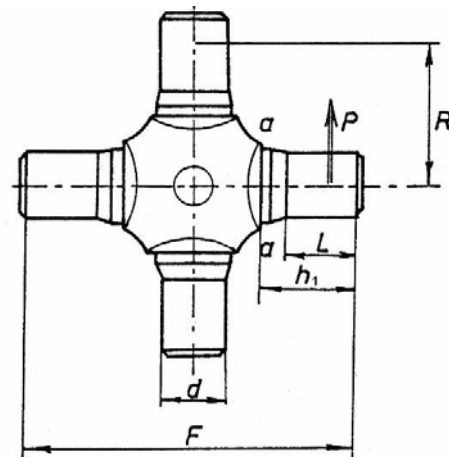

Figure 1. Cross shaft [5]

The cross shaft is loaded on bending and torsion torques. Bending stresses in the base of the cross shaft sleeve (critical section a-a), if ignoring the center hole for lubrication, can be determined as follows (Fig.1) [5]:

$$\sigma_s = \frac{Pl}{W_s}, \quad (1)$$

where:

¹⁾ University of Kragujevac, Faculty of Mechanical Engineering, Sestre Janjić 6, 34000 Kragujevac, SERBIA

$$l = h_1 - \frac{L}{2} \quad (2)$$

The maximum force on the inlet of the cross shaft is:

$$P = \frac{M_{u2\max}}{2R} = \frac{M_{u2\max}}{F-L} \quad (3)$$

and the resistant bending torque on the sleeve:

$$W_s = \frac{\pi d^3}{32} \quad (4)$$

so that the bending stress:

$$\sigma_s = \frac{32M_{u2\max} \left(h_1 - \frac{L}{2} \right)}{(F-L)\pi d^3} \quad (5)$$

In the equations, the main symbols are:

h_1 - distance between the front sleeve and the budget section,

L - length of the needle bearings,

F - the distance between the front of the cross shaft, and

d - sleeve diameter.

Shear stresses on the cross shaft can be determined by the equation:

$$\tau = \frac{4P}{\pi d^2} \quad (6)$$

Taking into account that the cross shaft can be made of different types of steel, some experiences [5] show that it is good that the bending stresses do not exceed 150-300 MPa for passenger cars and 150-250 MPa for commercial vehicles.

The analysis of the actual stress distribution and the behavior of cross shafts of Cardan joints in operation shows that the initial cracks, as the beginning of the destruction, usually occur in the zone below the nipple hole. The strength of the cross shaft can be increased with the construction solutions in which the central lubrication hole is set at the head of branches, as well as with increasing the radius of the curves between the sleeve and the middle part of the cross shaft.

Analytical calculation of the cross shaft of the Cardan joint

An analytical and a numerical calculation were carried out for the Cardan joint cross shaft that was in exploitation, using the actual measures from the model. The model parameters are then varied as well as the stress state of the numerical method in order to reach the best variant with the lowest stress [6, 7]. The basic data for the calculations are given in Table 1.

Table 1. Basic data

Name	Value
Entry power	$P_U=10$ kW
Entry number of rotation	$n_1=1500$ min ⁻¹
Slope	$\alpha_{12}=30^\circ$
Shear modulus	$G=0.8 \cdot 10^5$ MPa
Dimensions of cross shaft	$d=11.5$ mm
	$F=40$ mm
	$h_1=10.5$ mm
	$L=9$ mm

- Distance l

$$l = h_1 - \frac{L}{2} = 0,006 \text{ m}$$

- Torsion torque on the drive shaft

$$M_{U1} = \frac{P_U}{\pi \cdot n_1 \cdot 30} = 63,662 \text{ Nm}$$

- Maximum and minimum torsion torque

$$M_{u\max 2} = \frac{M_{U1}}{i_{12\min}} = 73,511 \text{ Nm}$$

$$M_{u\min 2} = \frac{M_{U1}}{i_{12\max}} = 55,133 \text{ Nm}$$

- Constant torque component on the output shaft

$$M_{2k} = M_{U1} \cdot \frac{1 + \cos \alpha_{12}}{2 \cos \alpha_{12}} = 68,586 \text{ Nm}$$

- Variable torque component on the output shaft

$$M_{2p} = M_{U1} \cdot \frac{\sin^2 \alpha_{12}}{2 \cos \alpha_{12}} = 9,189 \text{ Nm}$$

- Maximum and minimum torsion torque on the output shaft

$$M_{u2\max} = M_{2k} + M_{2p} = 77,775 \text{ Nm}$$

$$M_{u2\min} = M_{2k} - M_{2p} = 59,397 \text{ Nm}$$

- Maximum force on the branch of the cross shaft

$$P = \frac{M_{u2\max}}{F-L} = 2,509 \text{ kN}$$

- Resistant bending torque

$$W_s = \frac{\pi \cdot d^3}{32} = 1,439 \cdot 10^{-7} \text{ m}^3$$

- Bending stress

$$\sigma_s = \frac{P \cdot l}{W_s} = 100,8 \text{ MPa}$$

- Shear stress

$$\tau = \frac{4 \cdot P}{\pi \cdot d^2} = 24,15 \text{ MPa}$$

- Equivalent stress

$$\sigma_e = \sqrt{\sigma_s^2 + 3 \cdot \tau^2} = 109,2 \text{ MPa}$$

The stress is lower than the allowable stress which is $\sigma_d=150$ MPa.

Structural finite element analysis of the cross shaft

This part of the paper gives the structural finite element analysis, done in the CATIA® software, which will be used to check the analytical stress values obtained for the Cardan joint cross shafts as well as to check the effect of changes in the shape of the size of maximum stress. It will be shown how the changes on the model affect the maximum stress.

A cross shaft is a symmetrical element with four branches arranged at an angle of 90 degrees to each other. On each of these branches, there is the same force transmitted through the bearings. As the cross shaft is symmetrically loaded by the same four forces, the numerical analysis can extract and observe only one-quarter of the cross shaft, which is loaded by one force. Fig.2 presents a model pin cross and Fig.3 presents its quarter to be used in the finite element analysis.

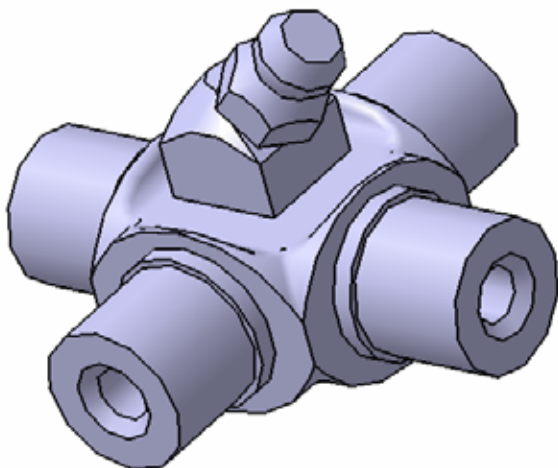

Figure 2. Cross shaft

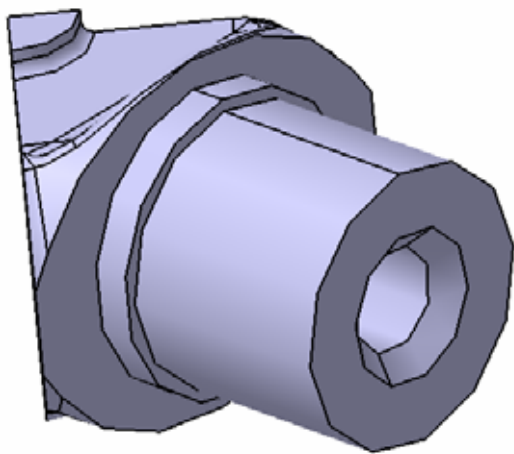

Figure 3. Quarter of the cross shaft

Calculating the cross shaft starts from a simplified model in order to get to the results as close as possible and then the finite element analysis is carried out on the actual model, and the modified models to reduce stress.

Several variants occur while preparing calculation and in order to seek optimum solutions. Each cross shaft is considered under the same conditions, loaded by the same kind of force in the same way, which has a value of 2059 N with a mesh size on the model of 1.5 x 0.5 mm and a local fragmentation of the mesh size in the same place from 1mm.

Variant 1: A simplified model is different from the real one because it has no opening for the passage of lubricants. Since the analytical calculation was made for the full pin, it is justifiable to use this pin. The image of this model is shown in Fig.4, and the stress distribution for it in Fig.5.

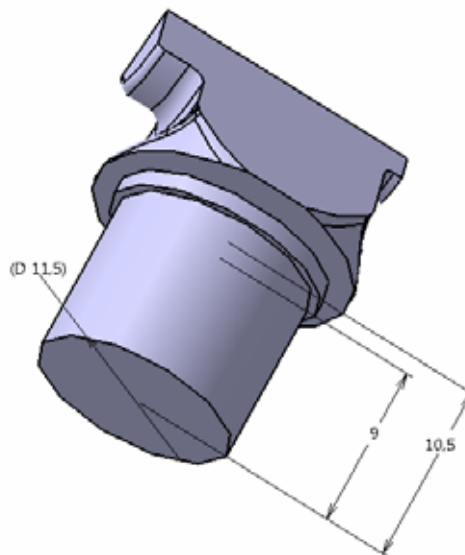

Figure 4. A quarter of the full model cross shaft (variant 1)

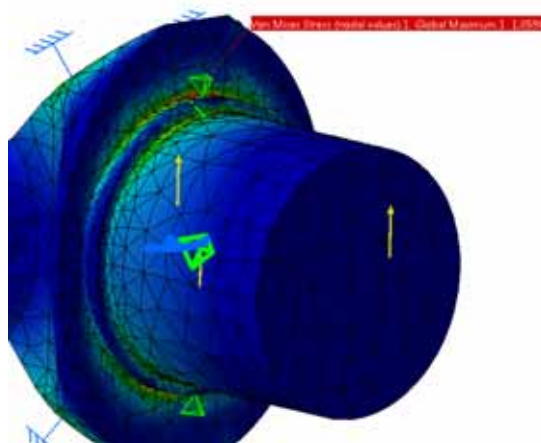

Figure 5. Stress of the quarter cross shaft (variant 1)

The maximum stress that occurs at the root is 105.981 MPa, which is about 3% different from the equivalent stress obtained by the analytical method, which has a value of 109.2 MPa. In order for the deviations of the low stress values to be reliable further on in the numerical method, the values obtained by the model modification are compared. It can be thus seen how small changes in the model affect the value of the maximum stress.

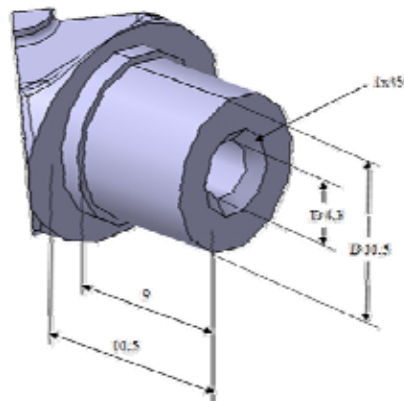

Figure 6. A quarter of the model cross shaft (variant 2)

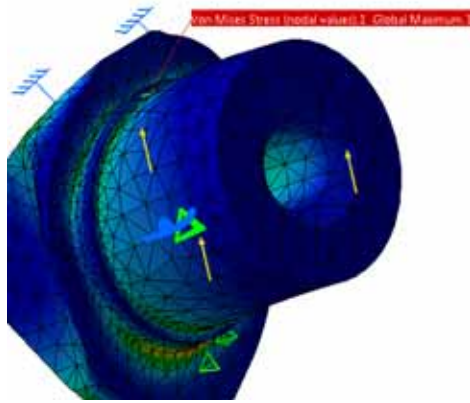

Figure 7. Stress of the quarter cross shaft (variant 2)

Variant 2: The actual cross shaft is different from the previous corresponding cross shaft simplified analytical model because it has the openings for the passage of lubricants. The model was made based on the actual cross shaft shown in Fig.6, and the stress distribution with the maximum values is shown in Fig.7.

The comparison of the results with the previous case shows that the values are very close and the stress slightly changed from 105.981 to 105.032 MPa, which is less than 1%. This value is lower than in the stress obtained analytically for about 4%. Therefore, we can conclude that lubricant openings have a negligible impact on the stress size.

Variant 3: Since the actual cross shaft has no curves, a curvature of 0.5mm at the turn and at the root of the shaft was introduced in order to affect the concentrated stress size reduction. Fig.8 presents the model derived from this change and the stress distribution is given in Fig.9.

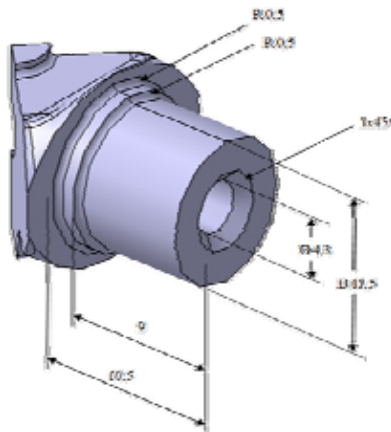

Figure 8. A quarter of the model cross shaft (variant 3)

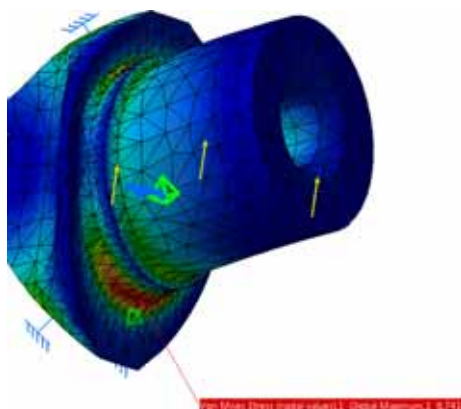

Figure 9. Stress of the quarter cross shaft (variant 3)

At the root the occurring maximum stress has a value of 87.411 MPa, which is almost 17% lower than the stress value of the previous model and up to 20% less than the stress obtained analytically, which means that the curve has an influence on the reduced stress concentration at the critical section.

Variant 4: In this case, a radius of 0.5 mm at the turn was detailed and the radius at the root was increased for 1mm. The modified model is shown in Fig.10 while the stress state of such a model is given in Fig.11.

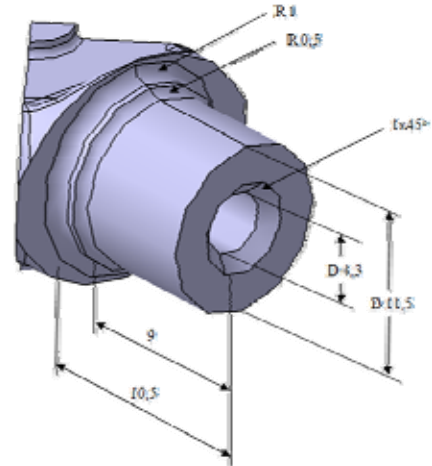

Figure 10. A quarter of the model cross shaft (variant 4)

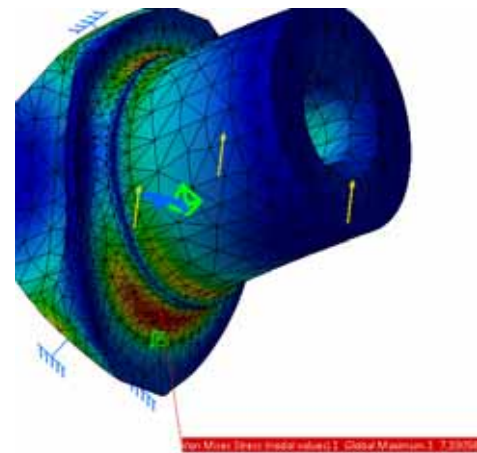

Figure 11. Stress of the quarter cross shaft (variant 4)

The maximum stress that occurs at the base has a value of 73.306 MPa, which means that the loss in the reduced stress concentration at that point is 16% when compared to the previous case and about 33% when compared to the analytically derived stress.

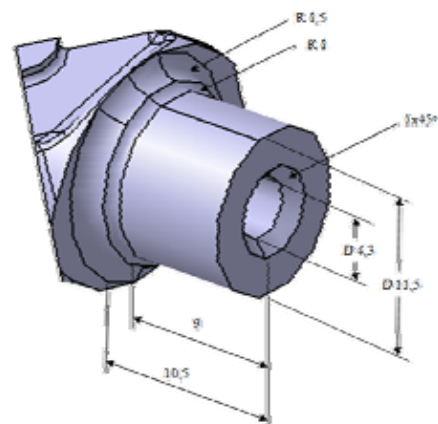

Figure 12. A quarter of the model cross shaft (variant 5)

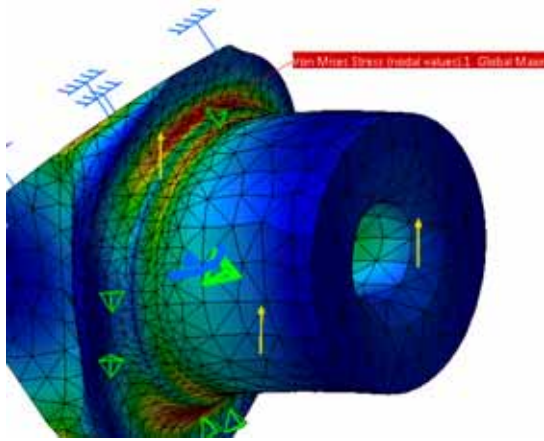

Figure 13. Stress of the quarter cross shaft (variant 5)

VARIANT 5: If we continue with radius increasing, and the radius in the root increases from 1 to 1.5 mm, there is a change of the stress state in the model and the stress concentration is reduced. At the same time, other dimensions remain unchanged from the previous example. Fig.12 gives the changed model and Fig.13 is the stress distribution.

Changing the radius of curves gives the maximum stress of 61.353 MPa that occurs at the root of the cross shaft, which is a decrease of 16% when compared to the previous example, with respect to the stress obtained by analytical reduction, which is 44%.

VARIANT 6: In search for a solution, a new model of the cross shaft has been created (Fig.14). The new cross shaft has a different design from the previous one, keeping the same assembly and functional measures, given in Fig.15.

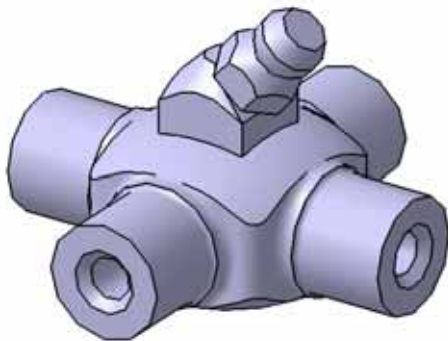

Figure 14. Model of the new cross shaft

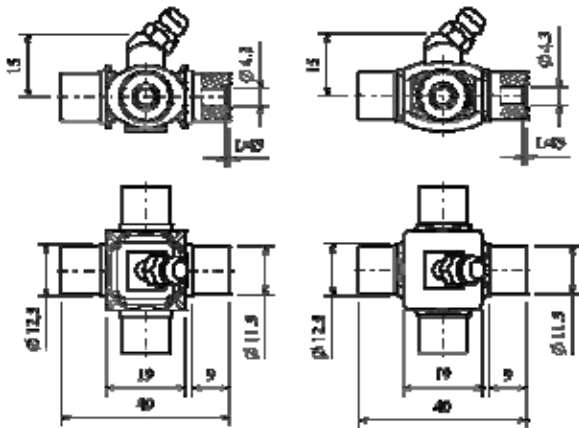

Figure 15. Dimensions a) real and b) new cross shaft

A new model of cross shaft is shown in Fig.16, while the distribution of its stress is given in Fig.17, where the model is

treated as the previous one, under the same conditions, the same load and the same mesh as in the previous variants.

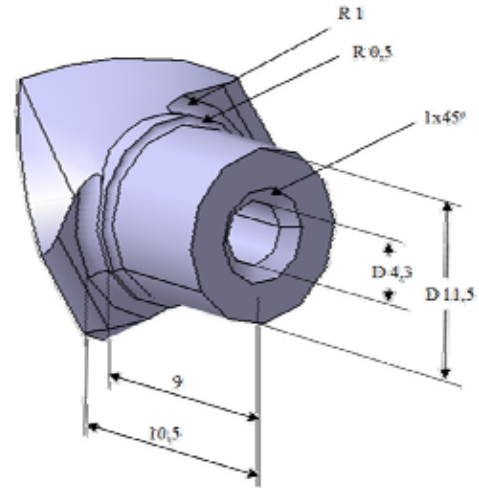

Figure 16. A quarter of the new model cross shaft (variant 6)

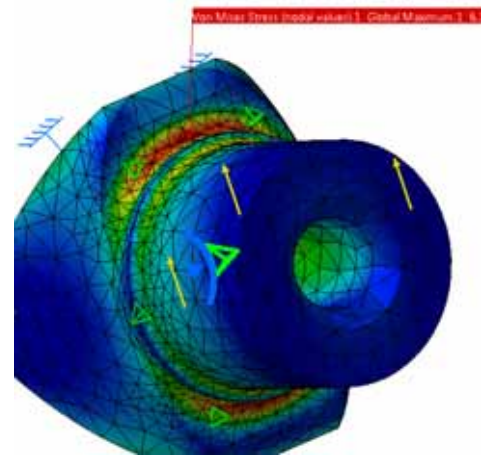

Figure 17. Stress of the quarter cross shaft (variant 6)

The maximum stress that occurs at the base has a value of 63.372 MPa, which is, when compared to the previous case, higher by 3%. When compared with the fourth variant, which has the same combination of radii, a new shaft has a lower stress by about 16%, and therefore its shape is the favorable variant of the previously applied forms.

Analysis of results

Based on the analysis of cross shafts, the cheapest option which has the lowest stress can be chosen. Table 2 gives the maximum stress variations at the cross shafts. The case with the lowest stress is marked and chosen as the most favorable one.

Table 2. Maximum stress with the percentage difference at the cross shaft

Cross shaft			
Analytically calculated stress: 109.2 MPa			
No	Maximum stress	Stress difference from the previous model [%]	Stress difference from the analytically calculated [%]
1	105.98 MPa		2.95
2	105.03 MPa	0.90	3.82
3	87.41 MPa	16.78	19.95
4	73.31 MPa	16.14	32.87
5	61.35 MPa	16.31	43.82
6	63.37 MPa	-3.29	41.97

Conclusion

Based on the analysis conducted for the Cardan joint cross shafts, it can be concluded that small changes in the shape can lead to large changes in the stress state of the investigated part.

Stress concentration can be reduced by curves. Increasing curves reduces stress concentration to a marginal extent, followed by an increase in curves increases and stress.

The results obtained by the analytical calculation cannot be reliably used in all cases as authoritative, because they are made for a general simplified model. With a more complex shape and keeping the same dimensions relevant for calculation, the stress can be significantly changed, which cannot be seen in the analytical calculation. Therefore, the numerical calculation has to be used since it takes into account the shape, and any change in the shape influences the change in the stress.

By examining the cross shaft, it was concluded that the grooves in the transition and base sleeve can reduce stresses up to 40%. The studies indicated that the cheapest option is when two different radius curves are given, with the smaller radius at the turn of a larger underlying sleeve.

To verify the results, it is desirable to use some other software in which the numerical method for the same models is loaded in the same way to get more reliable results.

Acknowledgment

The financial support for the work described in this paper was provided by the Serbian Ministry of Education and Science, Project (TR35033).

References

- [1] HUMMEL,R.S., CHASSAPIS,C.: *Configuration design and optimization of universal joints*, Mechanism and Machine Theory 1998, Vol.33, No.5, pp. 479-490.
- [2] HUMMEL,S.R., CHASSAPIS,C.: *Configuration design and optimization of universal joints with manufacturing tolerances*, Mechanism and Machine Theory 2000, Vol.35, pp.463-476.
- [3] HUMMEL,S.R.: *Adjustable universal driver*, United States Patent, 1993, No.5, pp.188-189.
- [4] TANASIJEVIĆ,S.: *Mechanical transmissions*, Yugoslav Tribology Society Kragujevac (in Serbian), 1994.
- [5] KOŽEVNIKOV,N.S., PERFILIEV D. P., *Cardan joints*, Mašgiz, Moskva (in Russian), 1962.
- [6] ŽIVKOVIĆ,K.: *Virtual simulation techniques and their applications in optimal design of industrial products*, Master thesis, Kragujevac (in Serbian), 2010.
- [7] ŽIVKOVIĆ,K., IVANOVIĆ,L., STOJANOVIĆ,B.: *The effect of geometry on the stress distribution of cross shaft*, The 7th International Scientific Conference Research and Development of Mechanical Elements and Systems IRMES 2011, Zlatibor, Serbia, April 27-28, 2011, pp.245-252.

Received: 21.02.2011.

Oblikovanje krstaste osovine sa aspekta nosivosti

Krstasta osovina je jedan od najvažnijih delova kardanskih vratila. U većini slučajeva dimenzije i vek kardanskog vratila zavise od krstaste osovine. Za obezbeđenje kvaliteta mašinskih delova, a takode u ovom slučaju krstaste osovine, neophodno je ispuniti osnovne konstrukcione zahteve koji su u vezi sa oblikom, funkcijom, materijalom i postupkom izrade. Oblik mašinskog dela je rezultat usklađivanja svih tih zahteva, a zadatak konstruktora je usavršavanje oblika sa ciljem iznalaženja najboljeg rešenja. U ovom radu je prikazan postupak utvrđivanja efekta promene geometrije na veličinu napona krstaste osovine kardanskog prenosa. Zadatak kardanskih prenosa je mehanički prenos snage i kretanja između vratila koja menjaju položaj osa u procesu eksploatacije ili su postavljena pod izvesnim uglom. Kritični napon na krstastoj osovini je izračunat analitičkom metodom i proveren numeričkim rešenjem. Pokazano je kako male promene u geometriji krstaste osovine mogu dovesti do znatnog smanjenja kritičnog napona. Iterativnim postupkom korekcije oblika i ponavljanjem numeričkog proračuna napona postignut je najpovoljniji odnos geometrije krstaste osovine i ekstremnih vrednosti napona.

Кljučне речи: krstasta osovina, kritični napon, numeričke metode, geometrijski oblik, kardansko vratilo.

Формирование пересечения крестообразного вала с учётом проектной мощности (Дизайн крестообразного вала с точки зрения ёмкости)

Пересечение моста крестообразного вала является одним из самых важных частей карданных шарниров. В большинстве случаев размер и срок службы карданного шарнира зависят от отбора мощности крестообразного вала. Для обеспечения качества механических частей, а также в этом случае и крестообразного вала, необходимо удовлетворить основным конструкционным требованиям, касающимся формы, функции, материальной и производственной процедур. Форма механической части является результатом выравнивания всех этих требований, и профессиональной задачей конструктора является подготовка форм с целью, чтобы найти лучшее решение. Настоящая работа описывает процесс определения влияния изменения геометрии на величину напряжения крестообразного вала карданной передачи. Задача карданной передачи механическая передача энергии и движения между осями шарниров, с целью изменения положений осей в процессе эксплуатации или они уже установлены под углом. Критическое напряжение на крестообразном вале было рассчитано с использованием аналитического метода и проверено путём численного решения. Здесь показано, что небольшие изменения в геометрии крестообразного вала могут привести к значительному снижению критического напряжения. Итерационным процессом коррекции форм

и повторением численных расчётов напряжения было достигнуто наиболее благоприятное соотношение геометрии крестообразного вала и крайних значений напряжений.

Кljučne riječi: крестообразный вал, критическое напряжение, численные методы, геометрическая форма, карданный шарнир (коробка отбора мощности).

Conception de l'axe en croix sous l'aspect de capacité

L'axe en forme de croix représente une part très importante chez les arbres à cardan. Dans la plupart des cas les dimensions et la durée de vie des arbres à cardan dépendent de l'axe en croix. Pour assurer la qualité des pièces mécaniques et de l'axe citée il est nécessaire de remplir les exigences basiques de construction qui sont en rapport avec la forme, la fonction, le matériel et le procédé de fabrication. La forme de la pièce mécanique est le résultat du réglage de tous ces exigences et la tâche du constructeur est de perfectionner cette forme pour trouver la meilleure solution. Dans ce travail on a présenté le procédé pour la détermination des effets de la modification de géométrie à la tension de l'axe en croix de l'arbre à cardan. Le rôle de cet arbre est de transmettre la force et le mouvement entre les arbres qui changent la position des axes pendant l'exploitation ou quand ils sont posés sous un certain angle. La tension critique chez l'axe en croix est calculée à l'aide de la méthode analytique et vérifiée par la solution numérique. On a démontré comment les petits changements de la géométrie de l'axe en croix peuvent conduire à la diminution significative de la tension critique. Par le procédé itératif de la correction de forme et la répétition du calcul numérique on a réussi le rapport le plus favorable entre la géométrie de l'axe en croix et les valeurs extrêmes de la tension.

Mots clés: axe en forme de croix, tension critique, méthodes numériques, forme géométrique, arbre à cardan.