

# Selective Hybrid EDFA/Raman Amplifier Placement to Avoid Lightpath Degradation in (C+L) Networks

Memedhe Ibrahim<sup>(1\*)</sup>, Giovanni Simone Sticca<sup>(1)</sup>, Francesco Musumeci<sup>(1)</sup>, Andrea Castoldi<sup>(2)</sup>, Rosanna Pastorelli<sup>(2)</sup> and Massimo Tornatore<sup>(1)</sup>

<sup>(1)</sup> Politecnico di Milano, <sup>(2)</sup> SM-Optics, \*corresponding author: [memedhe.ibrahimi@polimi.it](mailto:memedhe.ibrahimi@polimi.it)

**Abstract** We investigate optimized placement of hybrid EDFA/Raman amplifiers in (C+L) networks to avoid lightpath degradation due to ISRS. We numerically compare eight strategies for amplifier deployment showing that an optimized placement of Raman amplification can lead to 40% fewer amplifiers compared to baseline deployment practices. ©2022 The Author(s)

## Introduction

The sheer traffic increase stimulated by new 5G-and-beyond services requires continuous innovation in designing optical-network solutions that scale in terms of capacity, while minimizing equipment cost and ensuring lightpath Quality-of-Transmission (QoT).

Multi-band transmission<sup>[1]</sup> and high data-rate transponders employing advanced modulation formats<sup>[2]</sup> are two main technological enablers for capacity scaling. In particular, (C+L)-band transmission has been already deployed as an effective solution for capacity enhancement<sup>[3],[4]</sup>, but it has been observed that lightpaths in C-band may suffer QoT degradation due to Inter-channel Stimulated Raman Scattering (ISRS)<sup>[5]</sup> once the L-band starts being filled. To combat such degradations, hybrid EDFA/Raman amplification (HFA) is emerging as a novel effective solution<sup>[6],[7]</sup>.

We have previously investigated the problem of optimizing EDFA placement in metro/regional networks<sup>[8],[9]</sup> and showed that an optimized amplifier placement can lead to CapEx and, especially, OpEx savings. In this study, we address the problem of lightpath degradation by selectively upgrading (C+L) networks with HFA. We devise eight amplifier deployment strategies assuming amplifiers are deployed in two phases: 1) *phase-1*: C-band and L-band EDFA amplifiers are placed, and 2) *phase-2*: EDFA line amplifiers are selectively upgraded to hybrid EDFA/Raman amplifiers (HFA) by introducing Raman amplification.

The motivation to upgrade to HFA is twofold, as Raman amplification: *i*) enables higher spectral efficiency (hence, higher bit-rates to serve traffic demands), and *ii*) does not require to acquire new cabinet locations to deploy amplifiers (as in case of EDFA), hence leading to savings in CapEx and, especially OpEx.

Optimized deployment of Raman amplification in C-band has been investigated in previous works. Refs.<sup>[10]–[12]</sup> investigated how to selectively upgrade HFA in a brownfield scenario with

the objective of improving energy and spectral efficiency<sup>[10],[11]</sup> and minimizing network cost<sup>[12]</sup>. Similarly, Refs.<sup>[13]–[16]</sup> considered selective upgrade of EDFA amplifiers to HFA as a means to reduce the number of regenerators. Some recent works investigated the deployment of Raman amplifiers also in (C+L+S)-band networks<sup>[6],[7]</sup>. These works assume a baseline EDFA placement and deploy Raman amplification in all spans longer than 70 km. Results show that introducing Raman amplification in (C+L+S) networks allows to almost triple capacity with respect to C-band only transmission scenario, compared to a 2.4x increase obtainable without Raman amplification.

Compared to these works, we optimize the deployment of EDFA amplifiers and Raman amplifiers *i*) with the objective of minimizing their number and *ii*) ensure all the lightpaths degraded by ISRS can re-gain (or improve) their original SNR.

## Problem statement

The problem of optimizing the placement of EDFA and Raman amplifiers can be stated as follows: **Given** a network topology, set of traffic demands (characterized by source and destination nodes, data-rate and modulation format), and a set of candidate locations for amplifiers, **decide** the routing, spectrum allocation and modulation format of all traffic demands, and the placement of EDFA and Raman amplifiers, **constrained by** *i*) minimum lightpath QoT (SNR and received power), *ii*) spectrum continuity and contiguity and *iii*) fiber capacity, with the **objective** of minimizing the total number of EDFA and Raman amplifiers.

## Physical layer modelling

We assume that all links in the network can support (C+L) transmission and C-band and L-band EDFAs are placed in the same cabinet location. Regarding deployment of Raman amplifiers, we define a fiber span as *eligible* for upgrade to HFA if its length is at least 70 km. We assume that hybrid amplification operates at a moderate pumping regime with a counter-propagating pumping

**Tab. 1:** Strategies for deploying EDFA and hybrid EDFA/Raman amplification in (C+L) networks

phase-1	EDFA amplifier placement strategies
<b>B-EDFA</b>	All nodes are equipped with boosters and pre-amplifiers. Inline amplifiers are placed approximately every 80 kms.
<b>GA-EDFA</b>	A Genetic Algorithm (GA) is used to optimize placement of boosters, pre-amplifiers, and inline amplifiers. Candidate locations are considered every 20 kms. The objective is to minimize total number of EDFAs.
phase-2	Raman amplifier placement strategies
<b>R-all</b>	Raman amplification is deployed in all eligible spans, i.e., all spans longer than 70 km.
<b>R-unf</b>	Raman amplification is deployed only in spans that have unfeasible demands passing through. A demand is unfeasible if it does not meet the QoT requirement constraints.
<b>R-GA</b>	A Genetic Algorithm is used to optimize placement of Raman amplification. The objective is to minimize the total number of deployed Raman amplifiers, while QoT constraints of all lightpaths are met.
<b>R-GA-SNR</b>	A Genetic Algorithm is used to optimize placement of Raman amplification. The objective is to minimize the total number of Raman amplifiers, while limiting SNR degradation to meet the performance of R-all baseline.

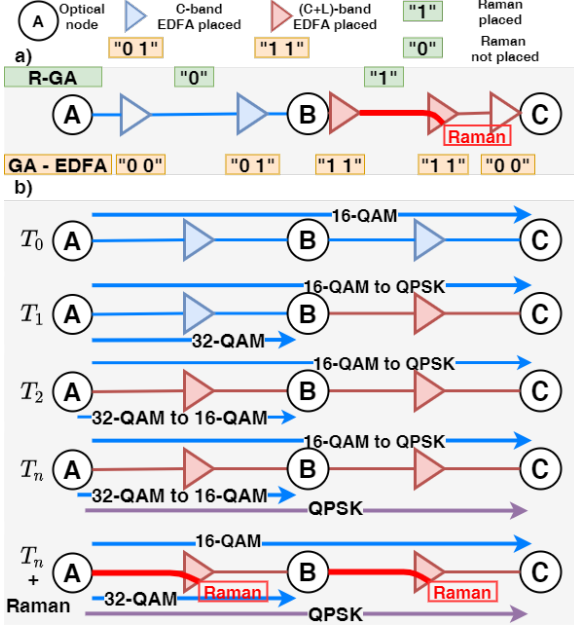

**Fig. 1:** a) Genetic algorithm encoding placing C and L band EDFAs and Raman amplifier; b) Illustrative example of deploying Raman amplification to avoid lightpath degradation

scheme and that Raman amplification recovers 60% of the span loss<sup>[17]</sup>. Additionally, deploying Raman amplification leads to a decrease in the noise figure from 5 dB to 0 dB (C-band) and from 6 dB to 1 dB (L-band)<sup>[17]</sup>. We utilize the closed-form Generalized Gaussian Noise model to estimate the Signal-to-Noise Ratio (SNR), accounting for ISRS<sup>[5]</sup>. We assume links operate with ASE loading, i.e., the worst-case scenario in terms of interference, and channels operate at optimal power according to LOGO strategy<sup>[18]</sup>.

A lightpath is defined as *feasible* if its SNR and received power are higher than a threshold that depends on data rate and modulation format<sup>[19]</sup>, plus a 2dB system margin. The received power must be above -18 dBm<sup>[8]</sup>.

### Optimized Placement of Hybrid EDFA/Raman Amplifiers in (C+L)-band Networks

Table 1 describes how the eight investigated amplifier placement strategies are identified. For *phase-1*, we consider two EDFA placement strategies: 1) a baseline EDFA placement (*B-EDFA*) and 2) an optimized EDFA placement (*GA-EDFA*)<sup>[9]</sup>. For *phase-2*, we consider four strategies to place Raman amplification: 1) place Ra-

man in all eligible spans (*R-all*)<sup>[7]</sup>; 2) place Raman in eligible spans that have unfeasible lightpaths (*R-unf*)<sup>[13]</sup>; 3) optimized placement of Raman amplifiers that minimizes their number (*R-GA*) and 4) optimized placement of Raman amplifiers that minimizes their number as long as a constraint on the minimal SNR is respected (*R-GA-SNR*). Please see Table 1 for details regarding these strategies and note that the resulting 8 strategies stem from the combination of the two options for *phase-1* and the four options for *phase-2*.

We developed a Genetic Algorithm (GA)<sup>[9]</sup> to optimize EDFA placement (*GA-EDFA*), and Raman placement (*R-GA*). Figure 1.a illustrates the encoding of C-band and L-band EDFA and Raman amplification placement with GA. The objective is to minimize the number of deployed amplifiers and ensure lightpath feasibility. To optimize Raman amplifier placement with GA, we model the eligible spans as a string of binary values, assuming "1" if Raman amplification is deployed, and "0" if not. We generate an initial solution at random and generate new populations by competition among members of the population and genetic operations, such as selection, mutation and crossover. We define the *fitness value* as the total number of placed amplifiers, while *feasibility* is defined as the ratio between the number of feasible lightpaths, and total number of lightpaths.

We test our placement strategies for incremental traffic, starting with a full-mesh traffic matrix (fully served in C-band) that gets annually incremented until all links are upgraded to C+L (once a link reaches its full capacity in C-band, it is upgraded to C+L). As upgrading to C+L may lead to signal degradation, we assume degraded lightpaths are switched to a lower modulation format to maintain service continuity. Therefore, to avoid these lightpath degradations, we optimize the placement of Raman amplifiers to restore the original SNR for the degraded lightpaths.

Figure 1.b shows an example of a link upgrade from C-band to (C+L), highlighting lightpath degradation and how such degradation can be avoided by selectively deploying Raman amplification. At step-0 ( $T_0$ ), lightpath (A,C) is assigned 16-QAM modulation format. At  $T_1$ , link B-C is upgraded to (C+L), and the signal degradation

**Tab. 2:** Total number of EDFA amplifiers and Raman amplifiers considering various amplifier placement strategies. minSNR and avgSNR for C-band and L-band for each deployment scenario, in dB units

EDFA strategies	% of degraded lightpaths	Number of EDFAs (C+L)	minSNR [dB] C-band, L-band	avgSNR [dB] C-band, L-band
B-EDFA	12%	280	13.77, 14.84	20.04, 18.66
GA-EDFA	19%	262	13.36, 14.12	19.53, 18.25
EDFA strategies	Raman strategies	Number of Raman	minSNR [dB] C-band, L-band	avgSNR [dB] C-band, L-band
B-EDFA	R-all	86	19.6, 19.6	25.4, 23.8
	R-unf	74	17.3, 17.8	25.1, 23.6
	R-GA	56	16.6, 16.9	23.1, 22.0
	R-GA-SNR	68	19.6, 19.6	25.1, 23.2
GA-EDFA	R-all	72	20.1, 19.3	25.7, 24.3
	R-unf	70	18.6, 19.3	25.7, 24.2
	R-GA	53	16.5, 17.8	23.3, 21.8
	R-GA-SNR	65	20.1, 19.3	25.1, 23.7

due to ISRS imposes to transmit demand (A,C) with QPSK modulation format. Similarly, demand (A,B) added at  $T_1$  is downgraded from 32-QAM to 16-QAM at step  $T_2$  due to upgrading link A-B. At step  $T_n$ , deploying Raman amplification ensures restoring the original spectral efficiency of all lightpaths without any service degradation.

### Illustrative numerical results

We compare the proposed amplifier placement strategies considering a realistic 14-node Japan topology<sup>[20]</sup>. We assume a full-mesh traffic matrix subject to a 30% step increase until all links in the network are upgraded to (C+L). We assume traffic with bit-rates between (100-500) Gbps and modulation format between QPSK to 64-QAM. We consider deploying two types of EDFA (with gain ranges as in<sup>[9]</sup>) and optimize EDFA placement at ingress of a node (pre-amplifier), at egress of a node (boosters), and along the fiber (inline).

As for phase-1, we compare EDFA placement strategies (B-EDFA and GA-EDFA) in terms of total number of EDFAs (C-band and L-band), and report the minimal SNR (minSNR) and average SNR (avgSNR) across all lightpaths. Table 2 shows GA-EDFA deploys 6% fewer amplifiers compared to B-EDFA, while achieving comparable SNR performance (in line with results in<sup>[9]</sup> for a national network). As for phase-2, we report the number of Raman amplifiers deployed, minSNR and avgSNR for C-band and L-band, for the four strategies to deploy Raman amplifiers, (R-all, R-unf, R-GA and R-GA-SNR), considering, as solution to phase-1, either B-EDFA or GA-EDFA.

First, let us note that introducing (C+L)-band transmission leads to a significant percentage of degraded lightpaths. Namely, **12%** and **19%** of lightpaths become unfeasible for B-EDFA and GA-EDFA, respectively. To avoid lightpath degradation, we upgrade EDFA amplification to HFA.

Second, let us compare the performance of the four Raman placement strategies assuming a Baseline-EDFA placement in phase-1. We observe that R-GA deploys 35% and 24% fewer Raman amplifiers compared to baseline R-all and R-unf, respectively. Optimizing Raman placement while constraining minSNR as in case of R-GA-

SNR leads to 21% and 8% fewer amplifiers compared to R-all and R-unf, respectively. The SNR values significantly improve when deploying Raman amplification compared to EDFA only strategies (B-EDFA and GA-EDFA). We observe a minSNR and avgSNR increase up to 6 dB in C-band and L-band. This confirms that HFA selective upgrade resolved lightpath degradation and ensured further improvement in SNR.

Third, let us compare the performance of Raman placement strategies assuming GA-EDFA deployment in phase-1. We observe that R-GA deploys 26% and 24% fewer amplifiers compared to baseline R-all and R-unf, respectively. R-GA-SNR, that minimizes number of Raman amplifiers while ensuring the same minSNR as in R-all, deploys 10% fewer amplifiers compared to R-all. Regarding lightpaths' SNR values, we observe that HFA selective upgrade allows to significantly increase minSNR and avgSNR (around 6 dB) compared to B-EDFA and GA-EDFA. Comparing lightpaths' SNR in various Raman placement strategies, we observe that R-all and R-GA-SNR reach the highest SNR performance, while R-GA is designed to minimize the number of Raman amplifiers without limiting SNR degradation.

If we now compare the amount of deployed Raman amplification considering B-EDFA and GA-EDFA, we can observe that an optimized EDFA placement, i.e., GA-EDFA, leads to a lower number of Raman amplifiers needed to recover lightpath degradation compared to a baseline EDFA placement, i.e., B-EDFA. In particular, R-GA with GA-EDFA deploys the lowest number of Raman amplifiers and compared to R-all with B-EDFA deploys almost 40% fewer Raman amplifiers. This confirms that an intelligent EDFA placement leads to deploying fewer Raman amplifiers and ensure avoiding lightpath degradation.

**Conclusion:** deploying Raman amplification allows to ensure lightpath feasibility and avoid service disruption without the need to acquire additional cabinet locations as in case of EDFA placement. We observed that an optimized placement of hybrid EDFA/Raman amplification can lead up to 40% fewer amplifiers compared to baseline placement strategies.

## References

- [1] A. Souza, R. Sadeghi, B. Correia, *et al.*, "Optimal pay-as-you-grow deployment on s+c+l multi-band systems", in *Optical Fiber Communication Conference (OFC) 2022*, Optica Publishing Group, 2022, W3F.4. DOI: 10.1364/OFC.2022.W3F.4.
- [2] J. Pedro, N. Costa, and S. Pato, "Optical transport network design beyond 100 Gbaud [Invited]", *Journal of Optical Communications and Networking*, vol. 12, no. 2, A123–A134, 2020. DOI: 10.1364/JOCN.12.00A123.
- [3] R. Sadeghi, B. Correia, A. Souza, *et al.*, "Transparent vs translucent multi-band optical networking: Capacity and energy analyses", *Journal of Lightwave Technology*, pp. 1–1, 2022. DOI: 10.1109/JLT.2022.3167908.
- [4] J. Pedro, N. Costa, and S. Sanders, "Cost-effective strategies to scale the capacity of regional optical transport networks", *Journal of Optical Communications and Networking*, vol. 14, no. 2, A154–A165, 2022. DOI: 10.1364/JOCN.440471.
- [5] D. Semrau, R. I. Killey, and P. Bayvel, "A closed-form approximation of the gaussian noise model in the presence of inter-channel stimulated raman scattering", *Journal of Lightwave Technology*, vol. 37, no. 9, pp. 1924–1936, 2019. DOI: 10.1109/JLT.2019.2895237.
- [6] A. Souza, N. Costa, J. Pedro, and J. Pires, "Optimized deployment of s-band and raman amplification to cost-effectively upgrade wideband optical networks", in *2021 European Conference on Optical Communication (ECOC)*, 2021, pp. 1–4. DOI: 10.1109/ECOC52684.2021.9605990.
- [7] —, "Raman amplification for simplified channel provisioning in wide-band optical networks", in *2022 Optical Fiber Communications Conference and Exhibition (OFC)*, 2022, pp. 1–3.
- [8] M. Ibrahim, O. Ayoub, F. Musumeci, *et al.*, "Minimum-cost optical amplifier placement in metro networks", *Journal of Lightwave Technology*, vol. 38, no. 12, pp. 3221–3228, 2020. DOI: 10.1109/JLT.2020.2991374.
- [9] M. Ibrahim, O. Ayoub, O. Karandin, *et al.*, "Qot-aware optical amplifier placement in filterless metro networks", *IEEE Communications Letters*, vol. 25, no. 3, pp. 931–935, 2021. DOI: 10.1109/LCOMM.2020.3034736.
- [10] J. L. Vizcaino, Y. Ye, F. Jimenez, A. Macho, and P. Krummrich, "Optimized amplifier placements for improved energy and spectral efficiency in protected mixed-line-rate networks", in *Optical Fiber Communication Conference*, Optical Society of America, 2014, Th1E–5.
- [11] J. L. Vizcaíno, Y. Ye, A. Macho, F. Jimenez, and P. M. Krummrich, "Increased energy-efficiency and capacity for mixed-line-rate wdm networks with hybrid raman-edfa amplification", in *2014 The European Conference on Optical Communication (ECOC)*, 2014, pp. 1–3. DOI: 10.1109/ECOC.2014.6964040.
- [12] J. L. Vizcaíno, Y. Ye, V. López, and P. M. Krummrich, "Cost evaluation of amplification strategies for wdm mixed-line-rate networks", in *2015 17th International Conference on Transparent Optical Networks (ICTON)*, IEEE, 2015, pp. 1–4.
- [13] J. Pedro and N. Costa, "Optimized hybrid raman/edfa amplifier placement for dwdm mesh networks", *Journal of Lightwave Technology*, vol. 36, no. 9, pp. 1552–1561, 2018. DOI: 10.1109/JLT.2017.2783678.
- [14] M. Cantono, A. Ferrari, U. Waheed, *et al.*, "Networking benefit of hybrid fiber amplification for lightpath regenerators saving", in *2017 Optical Fiber Communications Conference and Exhibition (OFC)*, 2017, pp. 1–3.
- [15] A. Ferrari, M. Cantono, U. Waheed, A. Ahmad, and V. Curri, "Networking benefits of advanced dsp techniques and hybrid fiber amplification", in *2017 19th International Conference on Transparent Optical Networks (ICTON)*, 2017, pp. 1–4. DOI: 10.1109/ICTON.2017.8025170.
- [16] A. Ferrari, A. Tanzi, S. Piciaccia, G. Galimberti, and V. Curri, "Selection of amplifier upgrades addressed by quality of transmission and routing space", in *2019 Optical Fiber Communications Conference and Exhibition (OFC)*, 2019, pp. 1–3.
- [17] M. Cantono, R. Gaudino, and V. Curri, "The statistical network assessment process (snap) to evaluate benefits of amplifiers and transponders' upgrades", in *18th Italian National Conference on Photonic Technologies (Fotonica 2016)*, 2016, pp. 1–4. DOI: 10.1049/cp.2016.0869.
- [18] P. Poggiolini, G. Bosco, A. Carena, V. Curri, Y. Jiang, and F. Forghieri, "The gn-model of fiber non-linear propagation and its applications", *Journal of Lightwave Technology*, vol. 32, no. 4, pp. 694–721, 2014. DOI: 10.1109/JLT.2013.2295208.
- [19] O. Karandin, O. Ayoub, M. Ibrahim, *et al.*, "Optical metro network design with low cost of equipment", in *2021 International Conference on Optical Network Design and Modeling (ONDM)*, 2021, pp. 1–4. DOI: 10.23919/ONDM51796.2021.9492458.
- [20] M. Ibrahim, H. Abdollahi, C. Rottondi, *et al.*, "Machine learning regression for qot estimation of unestablished lightpaths", *Journal of Optical Communications and Networking*, vol. 13, no. 4, B92–B101, 2021. DOI: 10.1364/JOCN.410694.