



FACULTY OF PHARMACEUTICAL SCIENCES

Ghent University

Faculty of Pharmaceutical Sciences

# INNOVATION IN PHARMACEUTICAL MANUFACTURING OF SOLID DOSAGE FORMS VIA CONTINUOUS WET GRANULATION

**Jurgen VERCRUYSE**

Industrial Pharmacist

Thesis submitted to obtain the degree of Doctor in Pharmaceutical Sciences

2014

Scientific Promoters: **Prof. dr. C. Vervaet, Prof. dr. J.P. Remon**

Laboratory of Pharmaceutical Technology, Ghent University

Industrial Promoter: **dr. I. Van Assche**

Department of Pharmaceutical Development, Janssen Pharmaceutica



The author and the promoters give the authorization to consult and to copy part of this thesis for personal use only. Any other use is limited by the Laws of Copyright, especially concerning the obligation to refer to the source whenever results are cited from this thesis.

Ghent, July 30<sup>th</sup>, 2014

The Promoters

The Author

Prof. dr. C. Vervaet

Prof. dr. J.P. Remon

dr. I. Van Assche

Jurgen Vercruysse



## TABLE OF CONTENTS

OUTLINE AND AIMS		1
INTRODUCTION	CONTINUOUS MANUFACTURING OF PHARMACEUTICALS	3
CHAPTER 1	CONTINUOUS TWIN SCREW GRANULATION: INFLUENCE OF PROCESS VARIABLES ON GRANULE AND TABLET QUALITY	41
CHAPTER 2	VISUALIZATION AND UNDERSTANDING OF THE GRANULATION LIQUID MIXING AND DISTRIBUTION DURING CONTINUOUS TWIN SCREW GRANULATION USING NIR CHEMICAL IMAGING	65
CHAPTER 3	IMPACT OF SCREW CONFIGURATION ON THE PARTICLE SIZE DISTRIBUTION OF GRANULES PRODUCED BY TWIN SCREW GRANULATION	99
CHAPTER 4	USE OF A CONTINUOUS TWIN SCREW GRANULATION AND DRYING SYSTEM DURING FORMULATION DEVELOPMENT AND PROCESS OPTIMIZATION	129
CHAPTER 5	STABILITY AND REPEATABILITY OF A CONTINUOUS TWIN SCREW GRANULATION AND DRYING SYSTEM	159
CHAPTER 6	EVALUATION OF POWDER BLENDING IN A TWIN SCREW GRANULATOR: AN EXPERIMENTAL APPROACH	187
GENERAL CONCLUSIONS AND FUTURE PERSPECTIVES		209
SUMMARY		215
SAMENVATTING		221
CURRICULUM VITAE		









## OUTLINE AND AIMS

---

For decades, the manufacturing of solid dosage forms in the pharmaceutical industry has been synonymous with batch processing. However, batch processes are often sensitive to variability (possibly resulting in batch rejection or reprocessing), high labor costs (due to the multiple manual interventions during processing), high production costs, excessive inventories and scale-up issues. On the other hand, many advantages are associated with continuous processing which are all related to important economic drivers for change (i.e. quality, cost and time). However, implementation of new technologies, methodologies and equipment is needed to allow transfer from batch to continuous manufacturing within the pharmaceutical industry.

As wet granulation is the most popular method to improve material properties (flow, homogeneity, compressibility) prior to tableting, it is obvious that a continuous wet granulation process is of high importance for a manufacturer of solid dosage forms. At the Laboratory of Pharmaceutical Technology (Ghent University) a continuous twin screw wet granulation process using a modified twin-screw extruder was developed. Based on this research work, GEA Pharma Systems developed a fully integrated 'from-powder-to-tablet' manufacturing line, the ConsiGma™ system, using twin screw granulation as an intermediate step for wet granulation of raw materials.

The overall objective of this project was to bridge the gap between the existing technology and its industrial implementation. Although technical know-how about the continuous granulation system is available at the manufacturer of this system, process knowledge (certainly towards specific pharmaceutical formulations) about this innovative manufacturing technique is limited within the pharmaceutical industry. Also in scientific literature the number of papers dealing with continuous wet granulation is limited. Therefore, the continuous granulation of pharmaceuticals by means of the ConsiGma™ system was investigated in order to (a) improve process knowledge and process understanding of this novel manufacturing tool for solid dosage forms and (b) simplify scale-up and transfers in pharmaceutical manufacturing.

To meet these objectives, the parameters affecting the quality of the end product manufactured via continuous wet granulation using the ConsiGma™ system were determined via a series of experiments which evaluated the different aspects of this granulation technique: influence of formulation, process and equipment parameters on granule and tablet quality, visualization and understanding of granulation liquid mixing and distribution, use of continuous granulation for formulation development and process optimization, stability and repeatability of the continuous granulation process and in-line blending capacity of the granulation unit.

# **INTRODUCTION**

## **CONTINUOUS MANUFACTURING OF**

### **PHARMACEUTICALS**

Parts of this chapter are published in:

C. Vervaet, J. Vercruyssen, J.P. Remon, T. De Beer, Continuous processing of pharmaceuticals, in: J. Swarbrick (Ed.), Encyclopedia of Pharmaceutical Science and Technology, 4<sup>th</sup> edition, Taylor and Francis, New York, 2013, 644-655.

### BATCH VERSUS CONTINUOUS MANUFACTURING

The pharmaceutical industry is under significant pressure to improve its manufacturing efficiency as increased competition from generics manufacturers, global reduction of healthcare budgets, limited product pipelines, low manufacturing efficiency, and increased development time and costs of new drugs have reduced profit margins. As a result continuous processing is gaining momentum for pharmaceutical manufacturing as it can be regarded as the ultimate form of lean manufacturing. The continuous manufacturing model has been used successfully for many years in the food, personal care, petrochemical, electronics and polymer industry to improve manufacturing efficiency and reduce costs, but its implementation by pharmaceutical manufacturers has been limited as batch processing remained the prevailing production method for pharmaceuticals.

During batch processing a specific quantity of material (i.e. API and excipients) is processed via a series of sequential unit operations (e.g. blending, granulation, drying, milling, tableting, coating and packaging during tablet production) to manufacture the final dosage form. Each unit operation is run using specific settings (defined during method development and validation) to modulate the properties of the material and when the predetermined endpoint (often as a function of time) of a specific unit operation is reached, the process cycle is stopped and the intermediate materials are packed off and stored in warehouses. Once the quality of the intermediates has been assessed in control labs using a wide array of off-line (and often destructive) analytical tools, the material is reloaded into the process to perform the next unit operation. As off-line quality analysis can take hours, days or even weeks, the material throughput time of a batch manufacturing process is significantly delayed using this segmented manufacturing approach. If the predefined quality standards after a unit operation are not met, the entire batch is either rejected or reprocessed, resulting in significant economic loss.

In contrast, a continuous manufacturing process integrates all unit operations into a continuous production train, without a start/stop phase at each unit operations (Fig. 1). It uses the 'one in, one out' principle where materials are continuously fed into the process and finished products continuously removed at the same rate to ensure a constant loading of the process chamber. Quality assurance during a continuous process requires continuous

monitoring of critical process parameters as well as continuous inspection of quality attributes of raw materials, intermediates and end product via at-line, on-line or in-line measurements in the process stream. Deviations can be rapidly detected and real-time adjustment of process parameters becomes possible via feedback loops to keep the system within its operational range and minimize material loss. Handling of intermediates in a continuous process is not required as raw materials are directly converted into finished products via an integrated process train, thus reducing material throughput time.

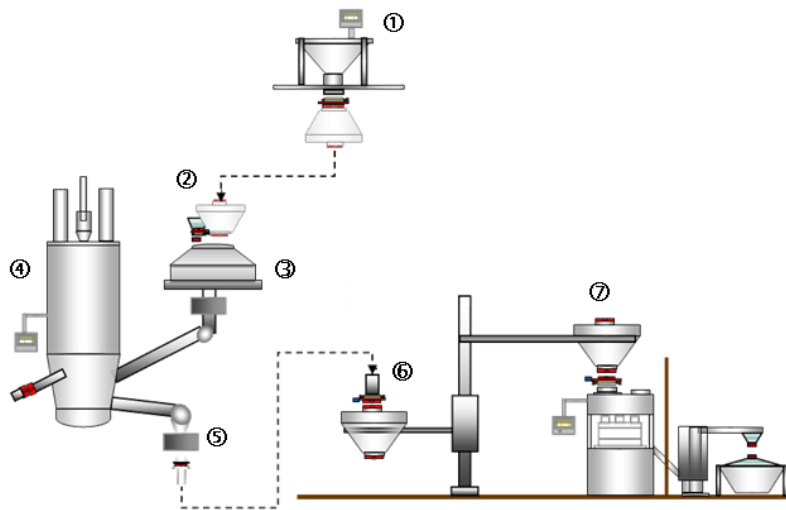

Figure 1: Flow chart of continuous production process for tablets via wet granulation: 1. Powder dispensing; 2. Wet granulation; 3. Wet milling; 4. Fluid bed drying; 5. Dry milling; 6. Blending of external phase; 7. Tablet compression (Courtesy of GEA Pharma Systems).

## BENEFITS OF CONTINUOUS PHARMACEUTICAL MANUFACTURING

Over the last decade significant efforts have been made to implement continuous processing in pharmaceutical manufacturing as most innovative companies as well as many generics manufacturers have recognized the multiple advantages of the continuous manufacturing concept over batch processing (Table 1) [1-6].

As batch processes are inherently wasteful at different levels, transition to continuous can result in significant gains:

- *Down-time*: the start/stop strategy of a batch process results in multiple interruptions of the production process, whereas an integrated continuous process ensures shorter throughput time. The Overall Asset Effectiveness (OAE) of batch processes is estimated at only 20-40%, while a seamless integrated and well-controlled continuous process could yield an OAE in excess of 80% [7].
- *Transfer*: individual steps of batch processes are often performed at different facilities, often by different companies (e.g. primary manufacturing of API and secondary manufacturing of final dosage form) or on different floors of the same facility (e.g. blending and tableting), requiring extensive material transfer.
- *Defects*: the entire batch is at risk when post-production analysis identifies a quality failure, whereas during continuous processing accurate process monitoring (with feedforward and feedback control) reduces the number of defects during a production run.
- *Labor*: batch operations require repeated manual interventions (e.g. discharging and transfer of intermediates, sampling for off-line analysis), while limited material handling is needed in a continuous process as raw materials are directly converted into finished product.
- *Quality control testing*: batch processing requires analyses at different stages of the process, whereas continuous manufacturing offers a single stage process with continuous on-line monitoring.
- *Inventory*: large inventories are endemic to batch processing as the intermediates need to be stored after each unit operation, pending off-line analysis. As continuous processing via a single process train offers the prospect of real-time release, inventories can be reduced to a minimum. Intermediate storage of batch-manufactured items also results in a loss of shelf-life.
- *Floor space*: not only the larger inventories of batch processes increase floor space requirements, the footprint of batch manufacturing is also higher as continuous processing technologies are far more compact compared to batch equipment, allowing to reduce the size of production facilities, capital investment and operational costs.

Batch processes have a fixed production scale determined by the dimensions of the equipment installed in the facility, resulting in overcapacity when the product becomes less viable and the inability to respond to increasing levels of growth. In contrast, a continuous process offers tremendous flexibility towards changing product demands as production time (and not the dimensions of the equipment) determines the overall amount of material processed. This flexibility to respond to market needs was cited as one of the primary drivers for other industries to move to continuous processing technologies. The flexibility towards the amount of material processed per run (by adjusting the total process time) also limits scale-up issues for continuous systems as there is no need to go through the costly and time-consuming validation process at different equipment scales (typically batch processing requires 3-5 scale-up steps to transfer a process from development stage to commercial batch production as the scale factor between different steps is generally limited to a factor 10).

Compared to other industries the cost of (poor) quality is high in the pharmaceutical industry as batch processes are often inefficient, the efficiency of a typical pharmaceutical batch process is between  $2\sigma$  and  $3\sigma$  (i.e. a yield between 69.2 and 93.3% and the cost of quality is 20-35% of the revenue in order to deal with failure investigations, complaints, reprocessing and scrapping of materials) [8]. Quality checks during batch processing are only performed after a unit operation, putting the entire batch at risk for rejection or reprocessing when a parameter is out-of-specifications. In contrast, quality is monitored without interruptions throughout a continuous manufacturing process. Provided that process control via feedback loops is in place during a continuous process to adjust process parameters and return specifications within their limits, only a limited amount of material must be scrapped. Continuous processing even allows immediate reprocessing of out-of-spec material as it can be re-introduced into the system via a recycle loop. Obviously manufacturers need to evaluate if recycle loops are an option as this complicates tracking of the materials to raw materials and process conditions, therefore knowledge of the width of material distribution time in the process chamber is essential.

Table 1: Benefits of continuous manufacturing within the pharmaceutical industry.

---

Accelerated market introduction of drugs
Reduced footprint (facility, utilities, waste)
Reduced costs (labor, operation, capital investment)
More efficient use of equipment
Less/no scale-up issues
Flexibility in supply to respond to market needs
'Lights out' operation possible (increased production without additional staff)
Faster throughput times
Time independent process (at steady-state conditions)
Higher process efficiency
Improved process control (continuous monitoring, integration of quality in process)
Improved process understanding
Consistent product quality
Real-time product release

---

As all material is in a continuous state of change from beginning to the end of a batch process, it is difficult to adjust for deviations of critical parameters during the process and the entire batch is at risk of rejection or rework. In contrast, once steady state conditions are attained in a continuous process only a limited amount of material is in the process chamber



at any given time. Hence, combined with a short residence time only a limited amount of material is at risk of being diverted to scrap or rework.

The cyclic nature of a batch process requires that utility systems are designed at a larger scale compared to continuous manufacturing: although this large capacity is needed to accommodate peak use during batch processing, the systems will be over-capacitated during much of the time when the equipment is not used (i.e. the downtime inherently connected to batch processing). In contrast, continuous processing allows to design utilities at a smaller scale as a lower, but constant burden is placed on all systems (electrical, water, HVAC, ...).

Containment of potent drugs at the operator/process interface becomes more challenging in a batch process given the fact that the material is multiple times handled between the different unit operations, requiring significant investment in specific designs at multiple stages of the process. In contrast converting raw materials directly into finished good via continuous processes eliminates the need for intermediate handling, limiting the number of material/operator interaction in a fully integrated continuous process.

Based on the multiple benefits (Table 1) offered by continuous manufacturing of pharmaceuticals, significant partnerships have been established to further develop this concept, e.g. *the multi-university C-SOPS consortium* (Center of Structured Organic Particulate Systems, involving academic partners of Rutgers, Purdue University, New Jersey Institute of Technology and University of Puerto Rico at Mayaguez, the consortium is developing systems to demonstrate the feasibility of sequential continuous blending, dry granulation, lubrication and tableting of powders and granules), *the CoCo-project* (Continuous processing, monitoring and control in pharmaceutical manufacturing, a consortium initiated in Finland involving partners from academia, industry as well as equipment vendors, its aim is to integrate continuous processing, measurement technology, process modeling and control as the basis for pharmaceutical manufacturing of the future), *MIT/Novartis Center for Continuous Manufacturing* (a 10-year, 65 million \$ research collaboration between the Massachusetts Institute of Technology and Novartis, developing a continuous and self-contained process from beginning to end, i.e. from manufacturing of drug substance (synthesis, crystallization, isolation, drying) to final drug product), *the Impulse consortium* (with participation of industrial partners from pharmaceutical, chemical

and consumer product businesses and from international research institutes within the EU, this consortium targets the integration of innovative process equipment for entire process systems in chemical and pharmaceutical production, in order to contribute to a knowledge-based manufacturing industry).

### **BARRIERS TO CONTINUOUS PHARMACEUTICAL MANUFACTURING**

The many advantages of continuous manufacturing ensure that it will gain a foothold within the pharmaceutical industry, but there are still some (true and perceived) challenges before this manufacturing concept will be adopted on a large scale by pharmaceutical manufacturers. These barriers are based on regulatory, cultural (inertia to change within conservative pharma business), educational (operators are trained for batch processes) as well as technical issues (batch equipment is widely available, continuous technologies are not sufficiently proven or are not available for specific applications) [1-6].

The 'wait-and-see' approach of the conservative pharmaceutical industry has significantly slowed down the implementation of continuous manufacturing. No one wanted to be the first to tackle the (technological and regulatory) hurdles, and meanwhile one sticks to the familiar and proven batch concept (despite its multiple drawbacks). Introduction of continuous processing will be accelerated as more active users demonstrate the validity of this concept.

The reluctance to invest in continuous technologies is also based on the prevalence of batch equipment in the pharmaceutical industry. Hence substantial equipment investments are not straightforward and a strong business case is needed to justify the replacement of batch equipment with novel continuous manufacturing technologies, especially as batch equipment is underutilized by the very nature of the batch concept and as mergers have resulted in a surplus of batch capacity within several companies. Based on these observations, continuous manufacturing will be most likely considered for new products, while a switch for existing products is only feasible in case of significant batch-to-batch variability or scale-up problems, conditions where an investment is required anyway.

The introduction of continuous processes has certainly been hampered by the perception that pharmaceutical products can only comply with regulatory quality requirements if they are produced by a batch process. As the regulatory aspects of batch technology has been tried and proven, manufacturers are reluctant to move towards continuous processing (despite higher efficiency and improved control) based on (perceived) higher compliance risks which could jeopardize the investments made to introduce a continuous line in a manufacturing plant. However, already in 2004 the PAT guidance for innovative pharmaceutical development, manufacturing and quality assurance (issued by the FDA) identified facilitating continuous processing as a means to improve quality, safety and efficiency [9]. As the regulators recognized the benefits of continuous processes towards quality and economic, it offers a window of opportunity to change the mindset within the industry as there are no regulatory hurdles (only lack of experience by the manufacturers as well as regulators) to adopt continuous manufacturing. Based on the FDA definition of a batch (*'A batch means a specific quantity of a drug or other material that is intended to have uniform character and quality, within specified acceptance limits, and is produced according to a single manufacturing order during the same cycle of manufacture'*), the regulators do not distinguish between batch and continuous processing as the batch definition refers to the quantity and not to the manufacturing mode (hence the use of the term 'batch' in the regulation does not impede anyone to pursue continuous processing as this is by definition a single cycle of manufacture).

How to define a batch in a continuous process? Whereas dosage forms manufactured via batch processing are identified by a unique batch number, allowing to trace this material to the raw materials used, the process conditions, the quality controls, etc. A batch number is less relevant for continuous processing as material can be processed over the span of several hours (even days or weeks). During this interval different batches of feed material (API and excipients) will have been processed and process settings will have fluctuated. Consequently a time stamp on the end product is more relevant as it allows linking a specific dosage form to specific process conditions as these are continuously stored electronically. Alternatively the material processed during the entire run could be subdivided, each part identified with a unique code linked to e.g. a specific API batch, process event [10].

When implementing continuous processing the industry has to move away from the traditionally used 3-batch validation concept as validation of a continuous process has to be performed in time (and not for a specific number of batches). While batch processing required the validation of a specific amount of product contained in the processor (e.g. content uniformity is determined via sampling at different spatial positions within the equipment), continuous processing requires validation across a certain period of time to ensure that key parameters (e.g. drug content, particle size, residual moisture content, tablet tensile strength) remain within limits during the entire production run. This obviously asks for a mentality change within the manufacturing plant as well as by the regulators.

Implementation of new technologies, methodologies and equipment is needed to allow transfer from batch to continuous manufacturing within the pharmaceutical industry. As the technology is not yet fully developed for all aspects (e.g. sensors to continually measure all critical process and/or material parameters do not yet exist), this hinders the rapid introduction of the continuous concept in the pharmaceutical area. In addition this shift of manufacturing mode requires a transformation of the current unit operation-oriented operators to highly-skilled personnel understanding the entire (continuous) process.

The perception that continuous processing is limited to high-volume products as continuous manufacturing is often used for this purpose in other industries (e.g. food, polymer). However, novel techniques have been introduced to allow continuous processing of limited volumes. As a result a continuous manufacturing process can already be used during an early stage in the product development process and afterwards be transferred to full-scale commercial production. As an example, the ConsiGma<sup>TM</sup> system (a continuous tablet production line commercialized by GEA Pharma Systems) allows small scale processing for product development and optimization as well as large scale manufacturing [3]. The introduction of continuous technologies capable of processing a limited amount of material (i.e. scale-down) also tackled another issue of continuous manufacturing: the perception that continuous processing per definition requires a long start-up and shut-down phase, resulting in unacceptable losses before steady state conditions are obtained when processing limited volumes of high-value pharmaceutical products. Techniques which rapidly attain equilibrium (i.e. steady state) in combination with a limited amount of material in the process chamber, effectively eliminate this drawback of continuous processing. Optimal

scale-down allows to use the same equipment during product development, manufacturing of stability and clinical batches and commercial scale manufacturing.

The mindset that continuous operations are rigid tailor-made processes for a specific product, while batch processing provides flexibility (e.g. batch equipment is multipurpose and depending on the needs the unit operations can be arranged in different order), challenges the developers of novel continuous manufacturing equipment to provide sufficient design flexibility to process different products on a specific system.

Whereas in batch processing all materials have the same residence time (although process conditions might vary in space, e.g. heat distribution in a reactor), the effect of the material residence time distribution in a continuous process must be controlled, preferably via a plug flow process with minimal backmixing.

The vision of the MIT/Novartis Center for Continuous Manufacturing is to design a fully integrated continuous system from API synthesis to final dosage form [11]. This strategy obviously requires the invention of novel technologies to link primary and secondary manufacturing into a single process train. However, most companies are not ready to take such a drastic approach and are focusing on the integration of existing unit operations for secondary manufacturing into a continuous process. As several unit operations (frequently used in a batch process) are continuous by nature (Table 2), integration of these systems into a continuous process can be used to overcome the conservatism in the pharmaceutical industry as such a process would be based on well-known technologies, thereby minimizing (commercial) risks.

Table 2: Unit operations used for secondary manufacturing of tablets.

<i>Inherently continuous</i>	<i>Batch</i>
Milling	Wet granulation
Spray drying	Melt granulation
Roller compaction	Drying
Tableting	Coating
Hot-melt extrusion	
Packaging	

## CONTINUOUS MANUFACTURING OF SOLID DOSAGE FORMS

Although applications of fully-integrated continuous production lines are currently limited within the pharmaceutical industry, continuous processes are not that uncommon as several unit operations are inherently continuous based on their first-in/first-out principle (although they are routinely used in batch mode) (Table 2). Hence a continuous tablet manufacturing line could be easily envisioned via direct compression (integration of continuous feeding (using multiple feeders), blending, tableting and packaging) or via dry granulation (integration of continuous feeding, blending, roller compaction, milling, blending (external phase), tableting and packaging). In contrast, continuous tableting lines requiring wet granulation and/or coating are difficult to achieve using the conventional equipment that is currently used for batch processing.

Below some examples are given of technologies that can be integrated into a continuous manufacturing line of tablets. Although continuous manufacturing will also be beneficial for other dosage forms (e.g. liquids, semisolids, aerosols, injectables, freeze dried products) [12], introduction of continuous tablet manufacture is most essential to validate this manufacturing concept within the pharma business given the widespread prevalence of tablets.

Whereas continuous powder feeding (using volumetric or loss-in-weight feeders) and continuous powder blending [13] have been described, a first challenge for continuous tablet manufacturing is the granulation phase. While dry granulation via roller compaction (Fig. 2) is a simple process that is continuous by nature, integration of continuous wet granulators suitable for pharmaceutical applications is not straightforward as many techniques suffer from several drawbacks (e.g. throughput too high, start-up/shut-down phase too long, large material holdup, wide material residence time distribution) to make them generally applicable. For a detailed review of the equipment available for continuous wet granulation (and their working principle) (Table 3) the reader is referred to the reviews by Vervaet and Remon [8, 14].

Continuous wet granulation has been described using a modified conventional fluid bed which is equipped with a specifically designed powder inlet valve and an air separator to retain undersized material in the process chamber, while agglomerates are removed from the granulation process as their larger mass allowed removal via the air classifier. However, material residence time in this design is difficult to control, and steady-state conditions were difficult to maintain as any deviation in the powder input and/or output rate is immediately reflected in the powder/liquid ratio, significantly affecting the rate of agglomeration [8].

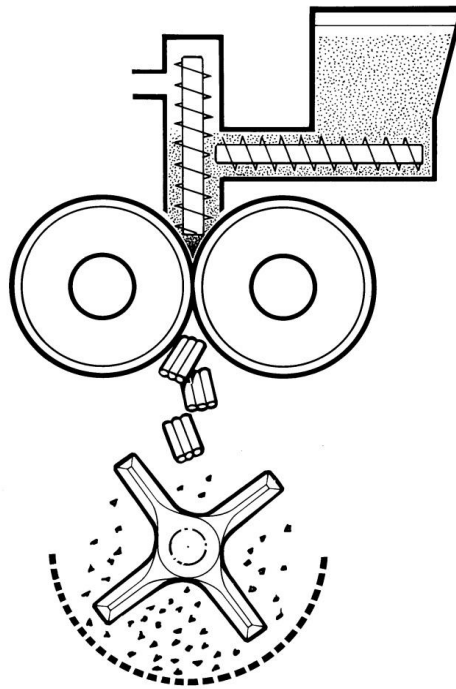

Figure 2: Schematic of the roller compaction process.

Table 3: Overview of techniques available for continuous wet granulation of pharmaceuticals.

---

Fluid-bed granulation

Spouted-bed granulation

Spray drying

Instant granulation

High-shear granulation

Extrusion-based granulation

Extrusion-spheronisation

---



Horizontal fluid beds (Fig. 3) (where different functional zones can be identified in the process chamber: feed, mixing/preheating, spraying, drying, cooling and discharge) are frequently used in the food industry, but its applicability in the pharmaceutical industry is likely to be limited as these systems are difficult to scale down and not based on plug flow of the powder bed. Although movement of the powder/granules is controlled via a specific air distribution plate, a sloped bottom plate and/or a vibrating process chamber, a long tail-off of the material residence time was observed (using a colorant as marker) by Gotthardt et al. [15]. In addition, the large capacity of the process chamber in horizontal fluid beds requires a long start-up phase and results in a large end-of-batch material holdup.

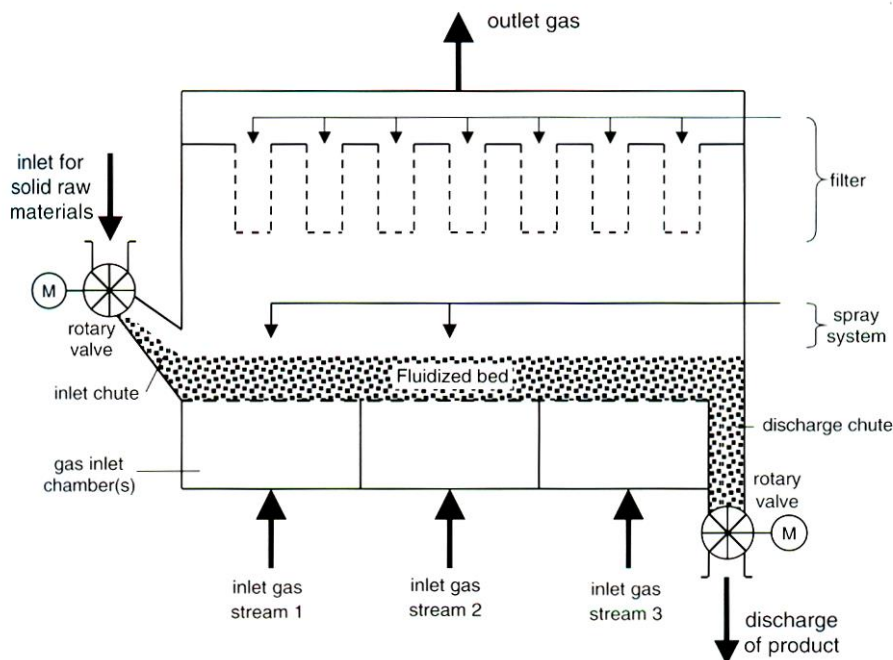

Figure 3: Schematic of the continuous horizontal fluid bed (from Ref. [8]).

Next to conventional fluid bed (where process air is introduced via a bottom screen), spouted bed technology can also be used for continuous wet granulation. In this technique high velocity fluidizing air enters the granulation chamber via longitudinal slots. The volume increase towards the top of the chamber results in a sharp drop of fluidizing air velocity, resulting in a controlled flow pattern of the particles. Nozzles positioned in the middle of the longitudinal slots ensure that the granulation liquid is sprayed at the point of the highest energy input, resulting in a homogeneous distribution of the granulation liquid. The forward

particle movement required for continuous processing is obtained via an angled air flow [16].

Although conventional one-stage spray-drying can be considered a continuous process, powders obtained via this technique are often not suited for tableting without further treatment as in most cases a powder with limited flowability is obtained (due to the small size of the spray dried particles). Therefore, to incorporate a spray-dryer in a fully continuous tablet production line, spray drying must be combined with another agglomeration technique to yield an agglomerated free-flowing product. For this purpose multi-stage systems combining a spray-drier with an externally or internally mounted fluid bed have been used [14, 17].

Despite the short residence time in the process chamber granules with consistent quality can be prepared using instant granulators, as the powder and liquid feed (after dispersion into small particles and droplets by a high-speed turbine) are intimately mixed at the periphery of the granulation chamber (Fig. 4). In addition, the short residence time ensures that material loss during start-up and shut-down is limited. However, the high throughput rate of most instant granulators limits their application for processing of pharmaceuticals.

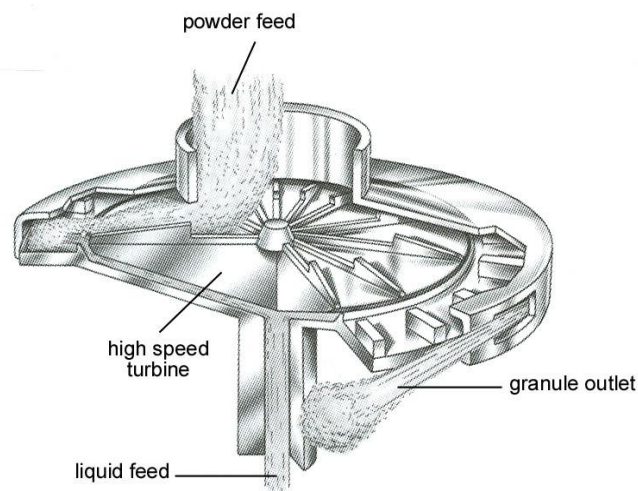

Figure 4: Schematic of instant granulator (from Ref. [14]).

A design which combined a conventional high shear mixer with an in-line wet sieving unit and multiple fluid bed units (for stepwise drying and cooling of the granules) resulted in a

quasi-continuous wet granulation unit (Glatt Multicell<sup>®</sup> system, Fig. 5), where individual packages of material (subunits) gradually moved through the process [18, 19]. Although not a fully continuous design (as granule output was not a continuous flow since consecutive subunits are transferred through the system), this approach offered tremendous flexibility towards the amount of material processed (defined by the number of subunits sequentially processed and by the subunit size, which is mainly determined by the dimensions of the high-shear mixer), allowing its use during development as well as production [8].

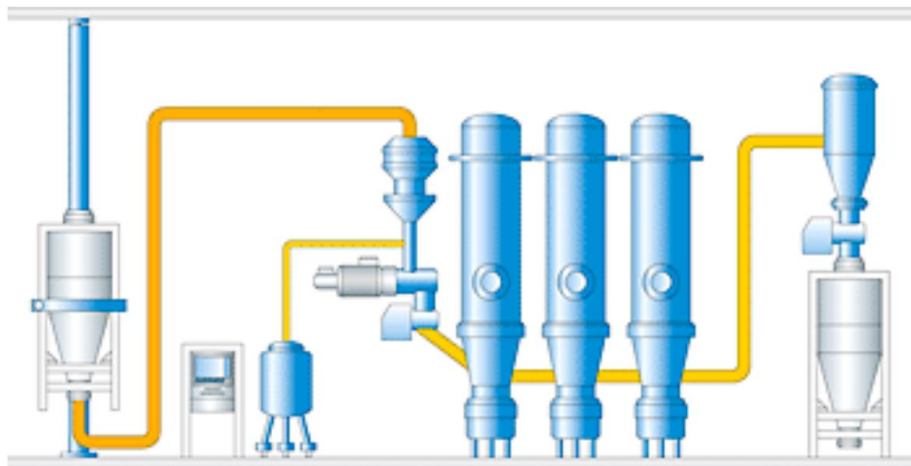

Figure 5: Glatt Multicell<sup>®</sup> system.

Chao and Steffens [20] presented a modified high shear mixer for continuous wet granulation as an outlet integrated into the mixing bowl allowed continuous discharge of the granulated material (using a perforated screen to control granule size) (Fig. 6). Wet granules were immediately transferred to a rotating horizontal cylindrical drying tunnel (using external heat via infrared and vacuum for rapid and gentle drying), with an internal scraper to ensure material flow via the first-in/first-out principle. The compact design of the system and the flexible material throughput are favorable for pharma applications, however, control over material residence time in the high shear mixing bowl is poor [8].

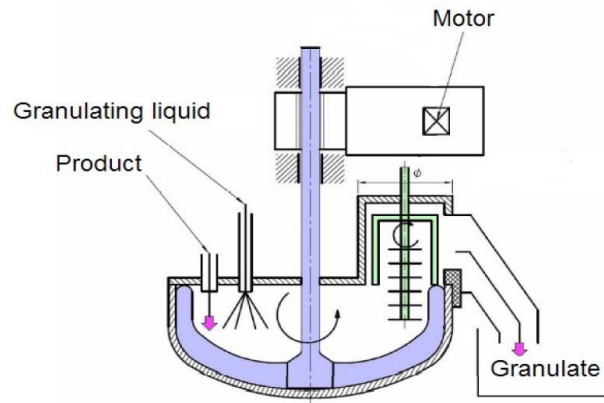

Figure 6: Continuous high shear mixer (from Ref. [20]).

A promising technique for continuous wet granulation is extrusion-based granulation [8, 14], where mixing paddles inside the barrel provide intense shear to agglomerate the wetted powder. As no die is placed at the barrel exit, densification of the material in the discharge zone does not occur and ready-to-use granules are continuously discharged. As this granulation process is very effective, the barrel length is short. As a result the fast material throughput ensures that steady state conditions are rapidly obtained, and that material loss due to end-of-process holdup is negligible, making this a suitable continuous technique during formulation development and process optimization. This technique also offers flexibility towards the granule characteristics (size, yield, fine fraction, porosity, friability, compressibility) as these depend on a number of key variables during the process (screw configuration, screw speed, process temperature, powder and liquid feed rate, primary particle size, filling degree of process chamber, ...). Evidently, monitoring and strict control of these parameters is of major importance. The versatility of this technique also extends its applications to continuous melt granulation [21], and to a direct granulation/tableting process (using a die to form a dense extrudate which was cut into tablets and dried) [22].

A specific wet granulation method is the manufacturing of spherical granules of uniform size (pellets) via extrusion/spheronisation [23]. While extrusion of a moist plastic mass is a continuous process by nature, continuous spheronisation is possible using two spheronisers in parallel (which are alternately used) (Fig. 7A), two spheronisers in sequence (forming a cascade system) (Fig. 7B), or using a single spheroniser with multiple concentric

spheronisation chambers (the granules being progressively transferred to the outer ring as they become more spherical) [24].

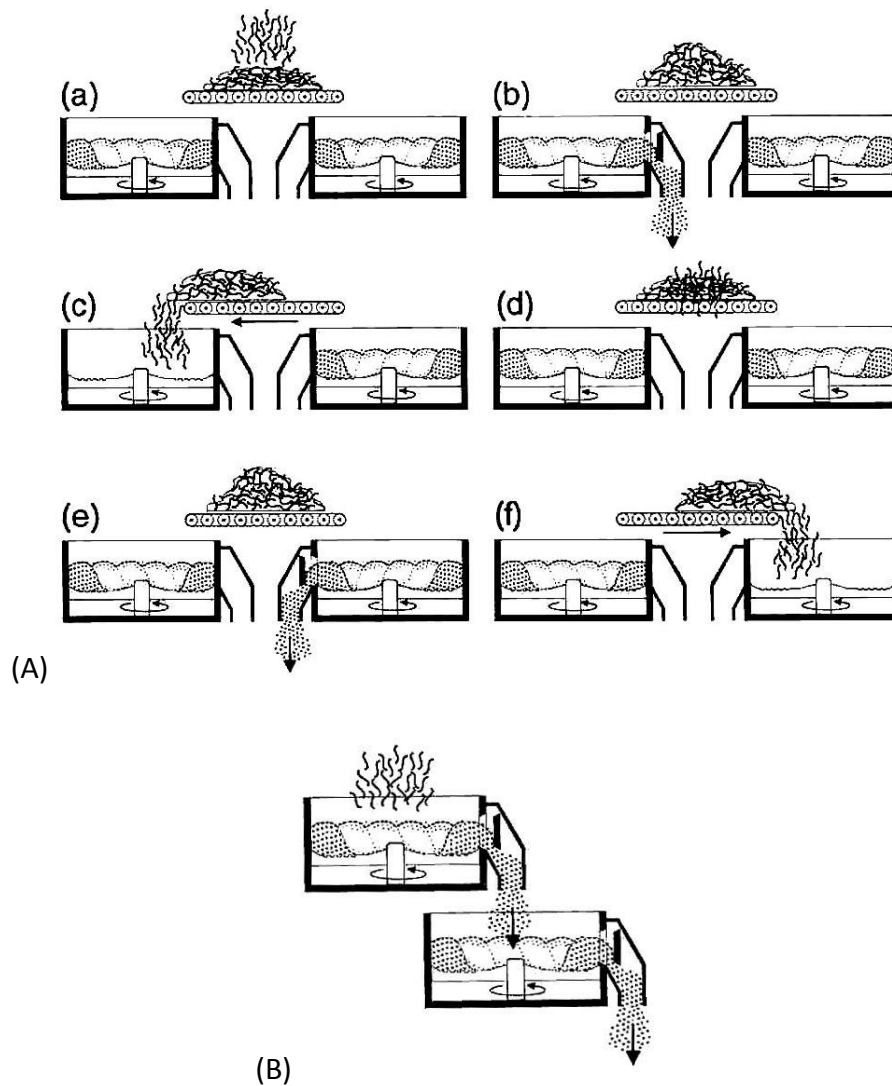

Figure 7: Continuous spheronisation using two parallel (A) and sequential (B) spheronisers.

Although systems for continuous coating are available [25], their integration into a continuous tablet production line remains a challenging aspect of the shift towards continuous manufacturing. Continuous coaters are mainly stretch version of conventional perforated pan coaters with tablets entering at one end and after coating exiting at the other end and have not been scaled-down, limiting their use at the process/product development stage). The potential loss of material (due to incomplete coating) at startup and shutdown in these systems is also significant. To solve this problem specific systems have been designed [25, 26], which e.g. are initially run as a batch process, once the batch

reaches its target coating level spraying is turned off and a weir plate is opened to control the gradual discharge of coated tablets. Simultaneously uncoated tablets are fed into the drum, as these pass through the system the spray nozzles are sequentially opened for gradual tablet layering. These continuous coating concepts with limited product loss resulted in a highly efficient coating process (for immediate as well as sustained release via aqueous film coating) [26], as the shallow tablet bed and high number of spray guns along the length of the coating chamber ensured a uniform coating. Next to pan coating technology, powder coating via electrostatic deposition [25] and sequential coating of limited tablet quantities in a fluid-bed type coater with short processing time (limited to a few minutes as the predictable movement of the particles in the spray zone rapidly achieved a uniform tablet coating) (i.e. quasi-continuous coating Supercell<sup>TM</sup> technology from GEA Pharma Systems) [27] have been presented for continuous coating purposes.

The increased interest in hot-melt extrusion within the pharmaceutical industry [28, 29] has greatly expanded the application range for continuous processing of pharmaceuticals. This thermal processing technique is inherently continuous and depending on the design of the formulation different drug release kinetics can be obtained: immediate release with enhanced dissolution and bioavailability of poorly water soluble drugs (e.g. via formation of solid dispersions in a hydrophilic matrix [30], as well as sustained release (e.g. using ethylcellulose as hydrophobic carrier to sustain drug release in combination with hydrophilic polymer to obtain zero-order release kinetics [31]. This technique also allows to manufacture a wide range of dosage forms depending on the dimensions of the die (e.g. films, rods, mini-tablets) and on the post-processing technique (e.g. milling, calendering, injection moulding [32]).

## FULLY INTEGRATED MANUFACTURING LINES

Whereas most equipment vendors only supply continuous process equipment for a specific subprocess of a tablet manufacturing line, GEA Pharma Systems recently introduced the ConsiGma™-continuous tableting line. The following processes can be distinguished in the modular design of the ConsiGma™ system (Fig. 8 and 9):

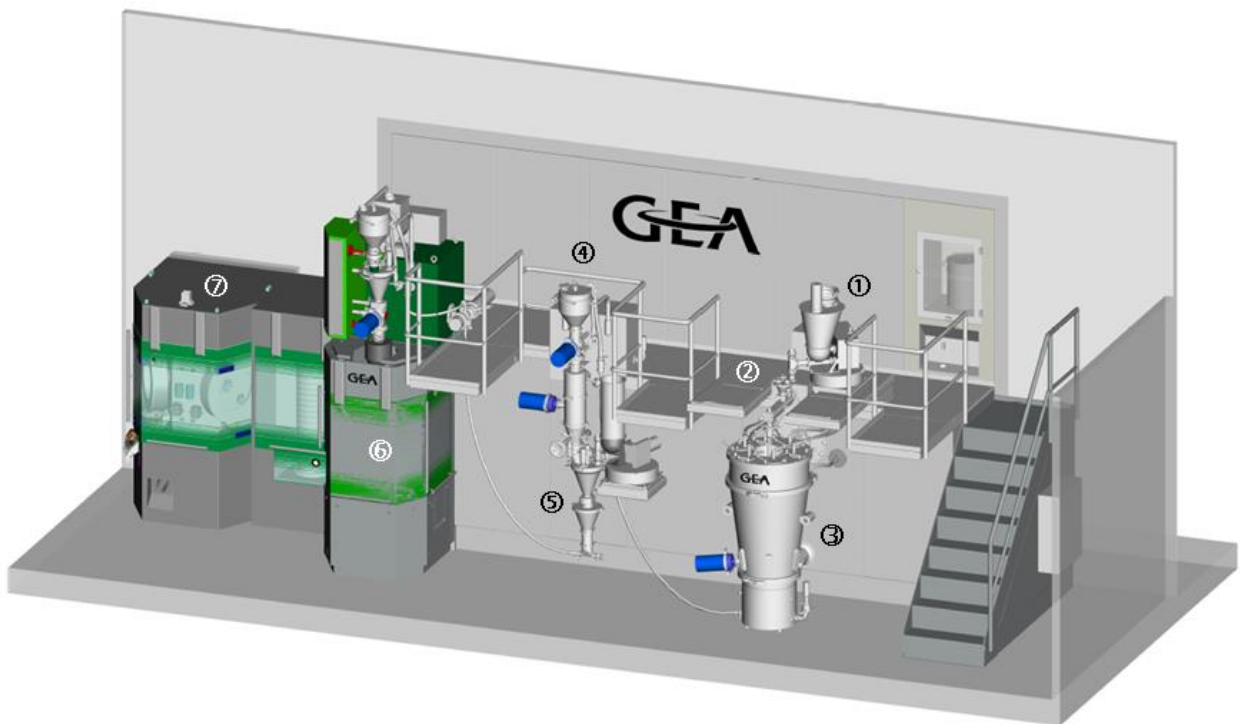

Figure 8: ConsiGma™-continuous tableting line: 1. Powder dispensing; 2. Screw-based wet granulation; 3. Segmented fluid bed; 4. Granule evaluation unit; 5. Blender (external phase); 6. Tablet compression; 7. Tablet coating (Courtesy of GEA Pharma Systems).

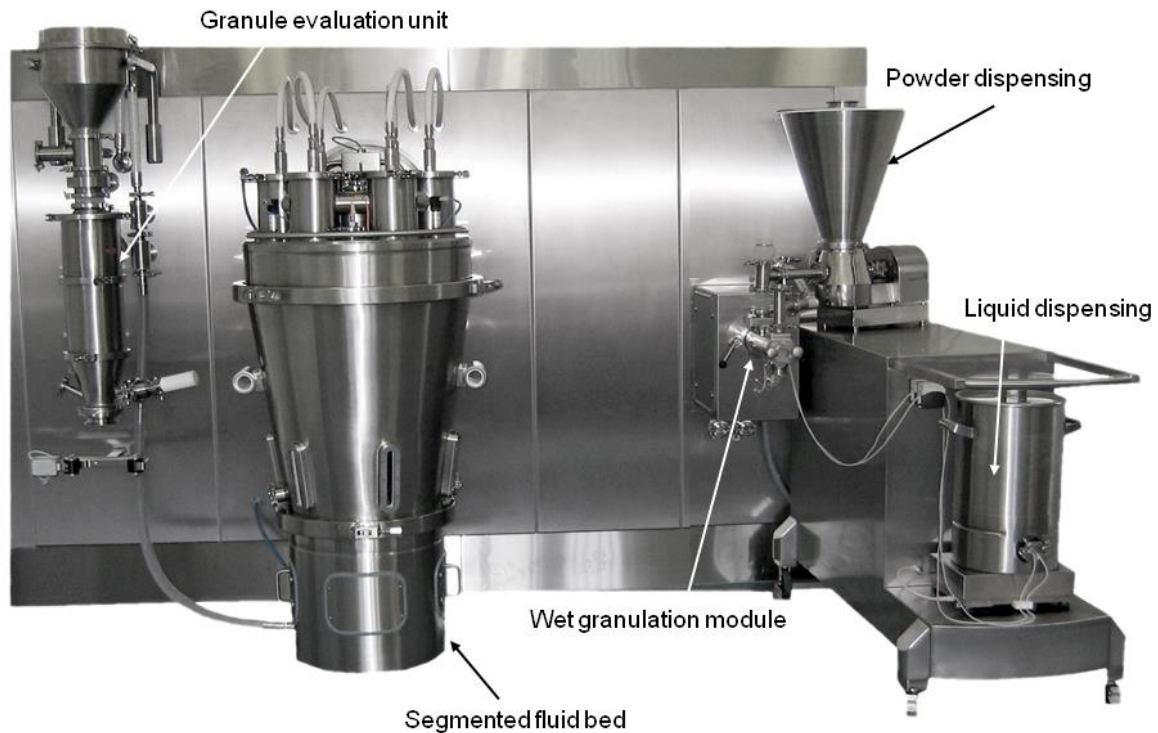

Figure 9: Granulation, drying and evaluation unit of the ConsiGma™-continuous tableting line (Courtesy of GEA Pharma Systems).

- Liquid and powder dosing via loss-in-weight feeders: powder dosing is possible from a container of preblended material, but as an alternative, several feeders can be used to dose each dry ingredient individually to a continuous blender to homogenize the formulation before entering the granulation unit.
- Granulation unit (Fig. 10): the core of this continuous wet granulator is a twin screw co-rotating granulation system. The modular nature of the screw elements allows to accommodate the different process steps (feeding, mixing, granulation, conveying, discharging) within the longitudinal granulation barrel ('processing-in-a-pipe'), e.g. kneading elements to provide the shear required for granulation, whereas screw elements in the feed and discharge zone are used to convey the material. After the powder feed zone, the liquid is added and the wetted particles are agglomerated in a short granulation chamber, limiting the material residence time in the granulation unit to a few seconds and minimizing the amount of material needed to evaluate different settings during formulation and process development. Twin screw



granulation offers flexibility towards the granule characteristics (e.g. size, yield, fine fraction, density, friability, compressibility) as these depend on a number of key variables during the process (e.g. screw configuration, screw speed, process temperature, powder and liquid feed rate, primary particle size, filling degree of process chamber).

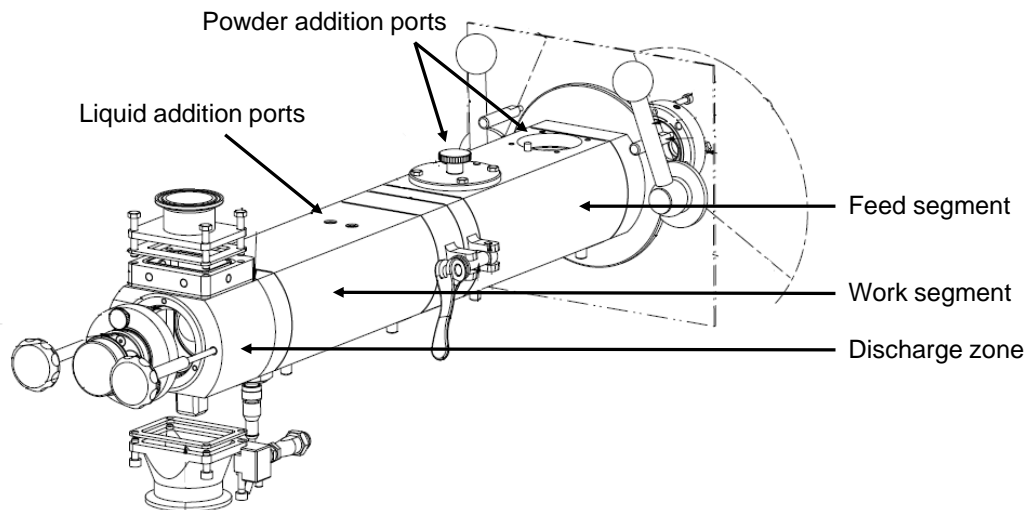

Figure 10: GEA continuous twin screw granulator (Courtesy of GEA Pharma Systems).

- Transfer to dryer: after wet granulation, the continuous flow of wet granules is transported (pneumatically or gravimetrically) to a fluid bed dryer.
- Drying unit (Fig. 11): drying is based on conventional fluid bed technology, but uses a segmented fluid bed dryer (6 separate identical drying cells) to ensure a first in/first out material flow. The continuous flow of granules is split into small packages (minimum 0.5 kg, maximum 1.5 kg in case of 25 kg/h throughput), and each package is dried in a separate drying cell. When the granules in a specific segment are dry, its content is transferred to the so-called granulation evaluation unit and refilled with a new package of wet granules.

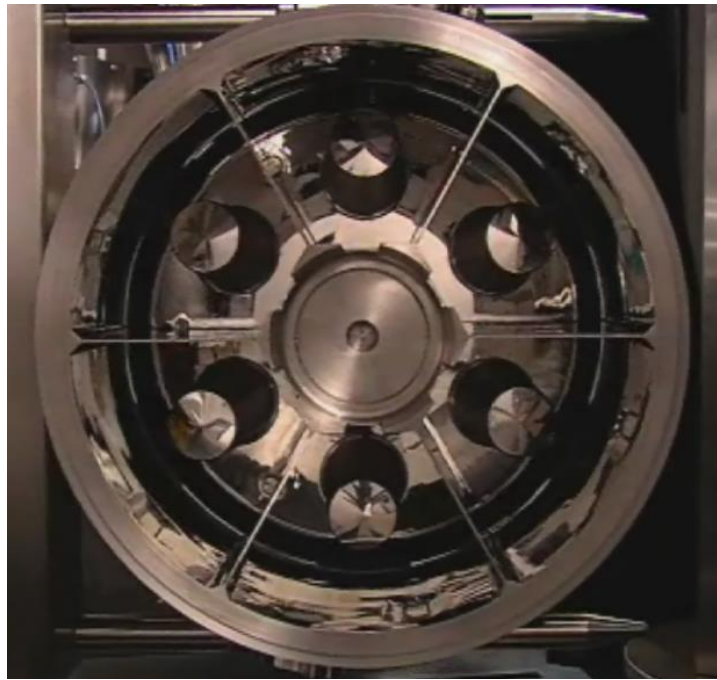

Figure 11: Segmented fluid bed dryer (Courtesy of GEA Pharma Systems).

- Granule evaluation unit: milling of the dried granules and evaluation of the granule properties (e.g. particle size, residual moisture content, content uniformity) using appropriate in-line PAT tools (e.g. NIR spectroscopy).
- Blender (external phase): after milling, the granules as well as the components of the external phase are loaded into a ribbon blender and mixed.
- Blender (lubricant): the blend of internal and external phase is transferred by pneumatic transport to a second ribbon blender where lubricant is added and mixed.
- Tablet press: the final blend is gravimetrically dosed from the second ribbon blender into the hopper of the tablet press and compressed to tablets.
- Coater: the Omega<sup>TM</sup> coater (GEA Pharma Systems) is the final unit operation in the continuous solid dosage form manufacturing process. This new type of coater subjects tablets to a cascading movement, enabling greater fluid application rates (i.e. faster build-up of the coating layer) compared to conventional coating pans (Fig. 12). In the Omega coater the tablet charge, under the influence of radial air knives, is induced to form a stable cascade inside a perforated drum rotating at high speed. A conventional spray nozzle is directed upwards into the cascade of “in-flight” tablets where substantially their full surface area is available to receive the coating on each

pass. Filling and discharge is automated and rapid. Depending on the size of the rotating drum, the capacity ranges between 15 and 30 kg/h. If needed, multiple modules (typically two, i.e. twin coater) (Fig. 12) can be combined to obtain sufficient coating capacity when these units are linked to a continuous tableting line. Obviously this coating concept generates a semi-continuous product flow [33].

Twin screw granulation (TSG) is often described as an 'extrusion-based' granulation process. However, the shear forces to which materials are exposed during screw-based granulation are far less from those during conventional extrusion mainly due to differences in equipment setup. During conventional (hot-melt) extrusion, materials are pushed through a die to yield an extruded material with a specific shape. In contrast, no die is placed at the barrel exit in a screw-based granulation process. As a result, densification of the material in the discharge zone does not occur and ready-to-use granules are continuously discharged. Furthermore, as the process chamber during a screw-based granulation process is only partially filled and pressure build-up is avoided due to the open outlet, a twin screw granulator is characterized by a lower power consumption.

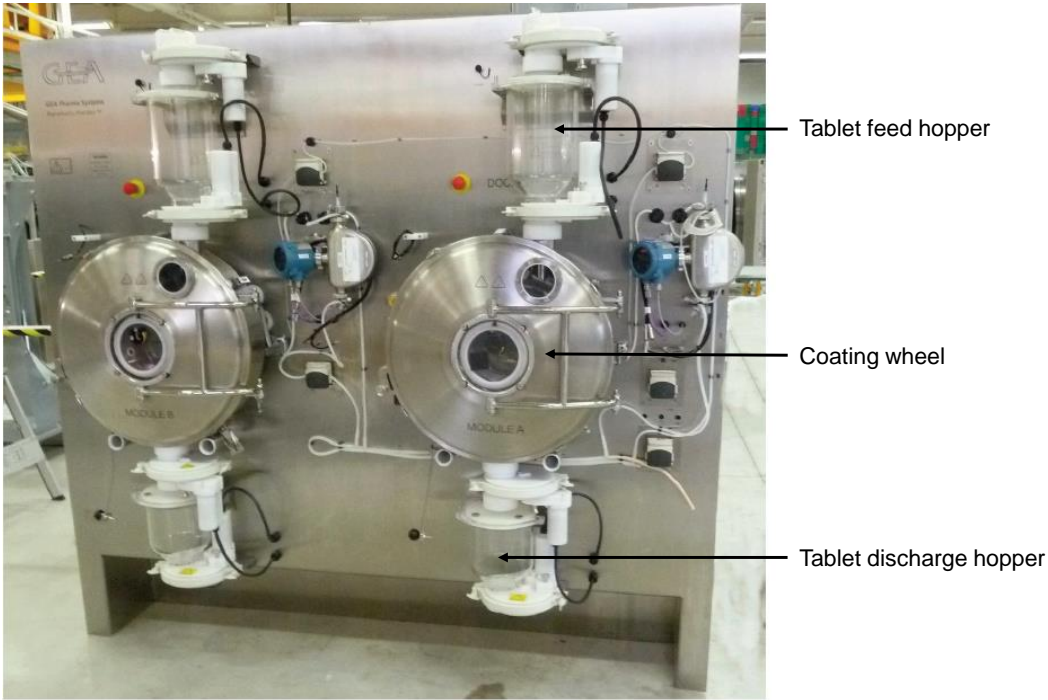
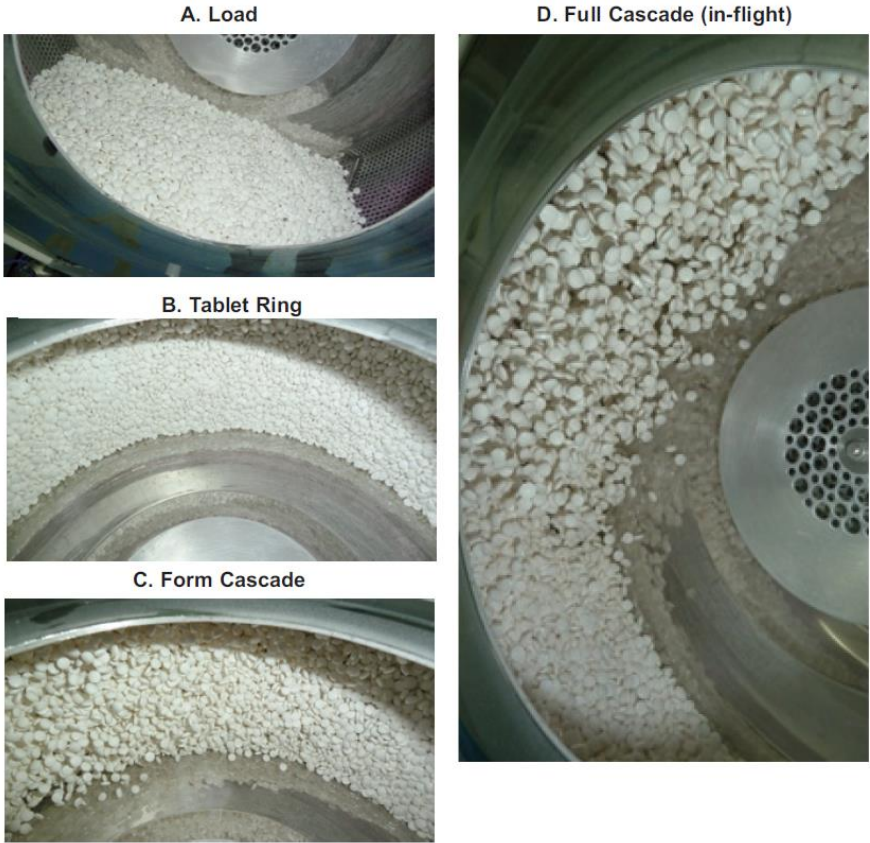

Figure 12: Phases of tablet motion in the Omega™ coater (top) and Omega™ twin-wheel coater (bottom) (from Ref. [33]).

Differences in processing between hot-melt extrusion and screw-based granulation also required re-designing of twin screw extruders to adapt them for wet granulation of powder compounds: whereas the screws and the walls of the screw chamber are lubricated with molten polymers during hot-melt extrusion, the chamber is only partially filled with wet mass during twin-screw granulation, providing insufficient lubrication. Therefore, the granulator screws inside the twin screw granulator of ConsiGma design have bearings at both end of the screws. Furthermore, the tolerance gap between the screws and the wall of the screw chamber is higher compared to the conventional tolerance gap for extrusion processes (0.37 mm vs. 0.10 mm), hence the compaction forces are limited during twin-screw granulation in order to maintain sufficient granule porosity for subsequent tableting.

The segmented fluid bed can operate with a low filling degree (e.g. only a single cell can be filled with wet granules), providing more flexibility for processing during the different stages of pharmaceutical development (compared to other continuous drying techniques). In addition, the amount of material at any time contained in the entire system is limited, minimizing the amount at risk in case of failure. The system marketed by GEA Pharma Systems is a strong case study for the efficiency of continuous processes as in less than 30 min powder is transformed into tablets, and for the smaller footprint of continuous operating plants. For a plant with a 1.5 billion tablets per year production capacity, overall investment was only a third compared to conventional batch processing, floor space was reduced to 30%, cost of quality dropped by 50% and yield increased 0.5% [3].

The MODCOS system, a continuous production line for wet granulation and drying of pharmaceuticals was recently introduced by Glatt in collaboration with Thermo Fisher Scientific. For the granulation step this system can be equipped either with a Thermo Fisher twin screw granulator (i.e. screw-based granulation) or with a Glatt GCG continuous mixer with granulation function. The cylindrical process chamber of Glatt GCG has a single configurable bladed agitator running along its length which conveys the material along the process chamber. The GCG mixer can be configured with various ports for the addition of granulation liquid along its axis which gives this unit the ability to act as dry powder mixer (i.e. without the addition of liquid) or granulator (i.e. when liquid is sprayed on the powder mixture during its passage through the mixer). The amount of shear within the blender is considered to be higher than a fluid bed environment, but due to the relatively large size and

moderate speed of the mixer, the shear created should be lower compared to a high shear granulator. As a result the device is categorized as a mid-shear granulator. The wet granules are continuously discharged into a Glatt GSF rotor mill to obtain the ideal particle size distribution.

For continuous drying the MODCOS system used a conventional GPCG fluid bed (GPCG 2 or 10 series) with a rotary chamber process insert which splits the fluid bed into segments. This insert contains the material in a specific segment of the fluid bed dryer, whereby the carousel-type insert rotates within the fluid bed chamber to forward the material from the inlet towards the discharge of the dryer. As the number of segments in the bed can be customized, the amount of materials per segment can be controlled.

Also the company Lödige recently launched a continuous granulation and drying system, the Granucon<sup>®</sup> concept. For wet granulation Lödige offers a single device that can be configured for dry mixing, low-mid shear wet granulation or high shear granulation. This unit is represented in Fig. 13 with its process chamber opened revealing the internal elements of the mixer. Lödige's technology is based on understanding how various blade configurations interact with the powder at different speeds. At low speeds, the blades impart insufficient energy into the powder to lift it out of the main bed and therefore it will only act as a mechanical mixer (Fig. 14a). As the speed of the impeller increases the bed is mechanically fluidized (Fig. 14b). This regime can be used as either a dry mixer, or a spray can be introduced to granulate the blend. As the speed is increased, and the centrifugal forces start to dominate the gravitational forces the particles are condensed into a "ring layer" around the outer edge of the mixer body (Fig. 14c). While this ring layer is not appropriate for mixing, it can be used for granulation purposes.

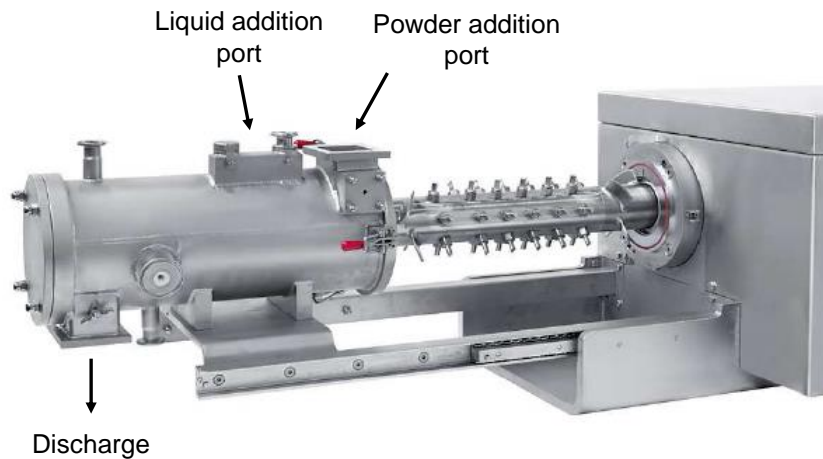

Figure 13: Lödige continuous granulator (Courtesy of Lödige).

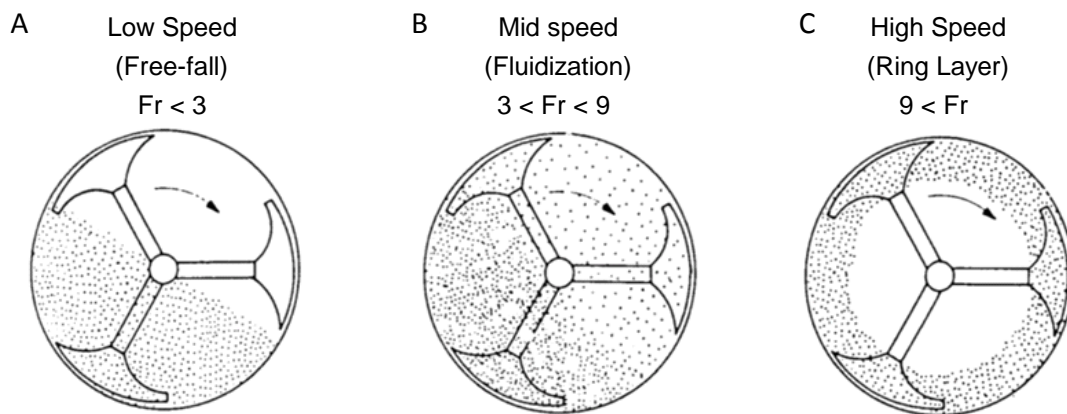

Figure 14: Classification of mixers based on Froude number.

The working principle of the linear dryer of the Granucon<sup>®</sup> line is based on conventional fluid bed drying (Fig. 15). However, to avoid a broad residence time distribution a screw was integrated at the bottom for a forced conveyance in the fluid bed dryer. The screw, which has a small clearance to the bottom of the process chamber, keeps the granules in segmented packets while its rotational speed determines the rate at which the material is transported through the dryer.

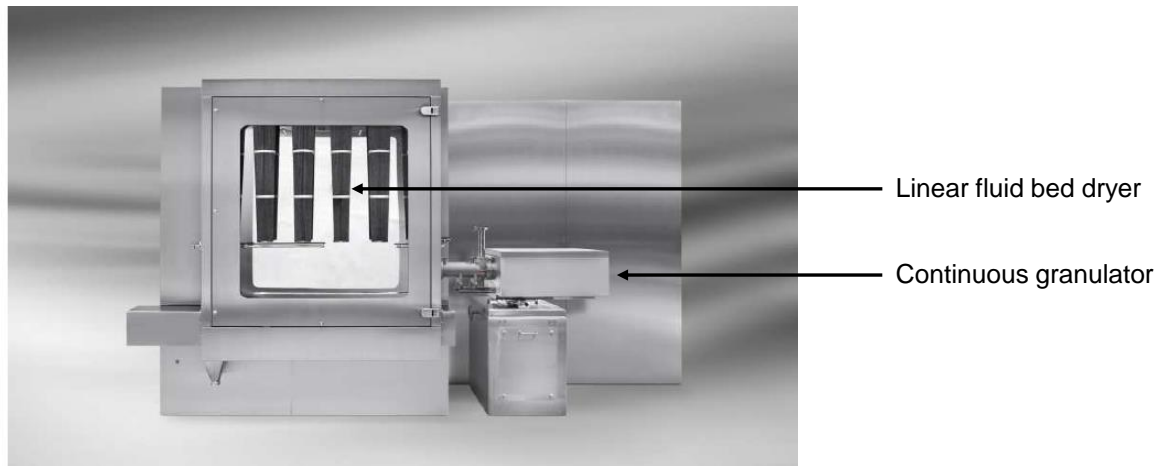

Figure 15: Lödige continuous granulation and drying system (Courtesy of Lödige).

### PROCESS CONTROL DURING CONTINUOUS MANUFACTURING

Since novel processes and untried manufacturing techniques increase the business risk, stringent process control of continuous processes is essential to persuade managers to accept the risks associated with the introduction of the continuous manufacturing concept. As large quantities can be processed during a single continuous run (which could span several hours, days, even weeks), post-production quality assessment is not an option as this would jeopardize the entire amount of material processed in case of quality deviation. Hence, continuous on-line quality monitoring is mandatory during continuous processing.

This approach is fully compatible with the Process Analytical Technologies (PAT) initiative of the FDA. PAT is a 'system for designing, analyzing and controlling manufacturing through timely measurements (i.e. during processing) of critical quality and performance attributes of raw and in-process materials and also processes with the goal of ensuring final product quality', which focuses on building quality into the product and manufacturing processes, as well as on continuous process improvement [34, 35].

PAT stimulates the introduction of new analytical tools to enhance process control and understanding during pharmaceutical development and manufacturing, in order to improve product quality, enhance production efficiency and reduce operational costs and waste (reprocessing, rejects).



Of vital importance to the success of PAT is the implementation of appropriate monitoring tools for analysis of the different critical product quality attributes. Depending on the process and material processed robust, low-maintenance, real-time, in-line monitoring tools must be selected (and implemented at the appropriate place in the process line) to provide information about specific product properties. For example in case of a hot-melt extrusion process any number of parameters (chemical and physical properties of API and excipients, melt viscosity, screw speed, shear force, pressure, temperature, residence time, content uniformity, porosity, shape, particle size, dissolution, ...) could be assessed via a combination of analytical techniques (e.g. NIR and Raman spectroscopy, rheometry, ultrasound, image analysis, ...). In addition to having on-line measuring capability it is key to adjust the process (while the product is being manufactured) to the target levels based on the in-line analysis. In this respect feedback as well as feedforward loops are critical for continuous and real-time adjustment of the critical process parameters based on data continuously collected via in-line monitoring (Fig. 16). For example, a feedforward control loop can continuously adjust process settings (e.g. amount of granulation liquid needed during wet granulation) in real-time based on on-line assessment of critical physical properties of API and/or excipients (e.g. particle size, moisture content, measured via NIR when feeding the material into the system) to maintain the properties of the end product (e.g. granule particle size distribution) within the target range. To compensate for fluctuations in raw materials via efficient feedforward control the availability of process models (elaborated based on historical process data) is essential for efficient feedforward control. Similarly feedback controls can adjust settings of e.g. feeders and granulators if on-line analyzers detected a particle size (distribution) outside the required range prior to tableting. This approach is not possible with batch processes as these are time- and scale-dependent, and often poorly understood. In contrast, continuous processes at steady-state conditions (where time is not a factor) are time-independent and better understood, allowing mathematical tools to model these processes.

A crucial factor to enable continuous manufacturing is that quality is built into the product throughout the process and not tested into the final product (as for batch processes). This is supported by the PAT initiative as well as by the Quality by Design (QbD) approach. This requires companies to develop processes via design of experiments to define the design space ('the multi-dimensional combination and interaction of input variables (e.g. material

properties) and process parameters that have demonstrated to provide quality assurance') [36], to understand the process limitations and to determine the limits where a product meeting the specifications can be assured [37].

A science-based approach via PAT and QbD of continuous manufacturing processes will ultimately support real-time product release, based on sufficient product and process knowledge, insight in the variability of parameters on process and product quality, use of robust but flexible manufacturing, possibility to rapidly detect and compensate deviations via high-frequency in-line monitoring.

Modern quality assurance systems implemented for continuous processing will move from for a rigid process and offer the possibility of continuous improvement towards a system with minimal deviation from the optimum.

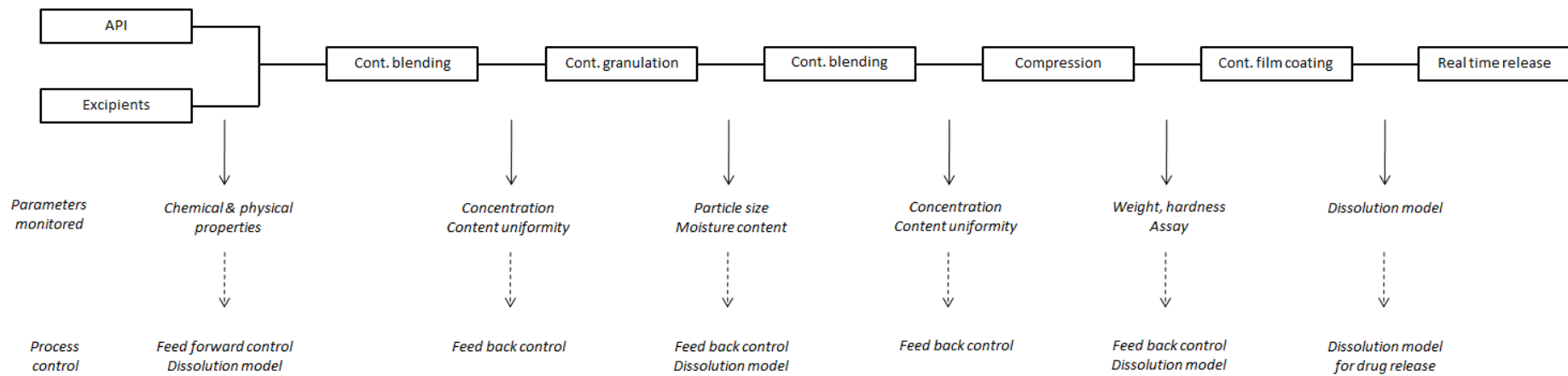

Figure 16: Flow chart of continuous tablet manufacturing line, highlighting the on-line monitored parameters via PAT-tools, and the feedforward and feedback controls.

### CONCLUSIONS

Historically, large profit margins within the pharmaceutical sector allowed to accommodate inefficiencies of the drug manufacturing process, as manufacturing contributed for only a small part to the overall cost of a drug product. However, the increasing difficulty to bring new drugs (let alone blockbusters) to market, increased competition from generics and shrinking health budgets have induced a mentality change that all pharmaceutical processes (including manufacturing) should run as efficient and cost-effective as possible. Continuous manufacturing offers the possibility to the pharmaceutical industry to reduce the cost of manufacturing and to improve efficiency and productivity. As a result continuous manufacturing (as the ultimate form of lean manufacturing) is rapidly gaining momentum within the pharmaceutical sector. As technical and/or regulatory barriers (true or perceived) will be removed over the coming years, more potential users will recognize the benefits of this manufacturing model and its gradual implementation will provide a significant contribution to survival in the new economic era.

**REFERENCES**

- [1] M. Mollan, M. Loyada, Continuous processing in pharmaceutical manufacturing, *American Pharmaceutical Review*, 7 (2004) 70-75.
- [2] F. Pavlou, K. Nepveux, K. Schoeters, Continuous processing: Is the pharma industry finally coming round the idea?, *Pharmaceutical Technology Europe*, 22 (2010) 44-50.
- [3] A. Pellek, P. Van Arnum, Continuous processing: moving with or against the manufacturing flow, *Pharmaceutical Technology*, 9 (2008) 52-58.
- [4] K. Plumb, Continuous processing in the pharmaceutical industry: changing the mind set, *Chemical Engineering Research and Design*, 83 (2005) 730-738.
- [5] M. Rios, Continuous processing - Finally, *Pharmaceutical Technology*, April (2007).
- [6] K. Schoeters, Overcoming the misconceptions of continuous processing, *Pharmaceutical Technology Europe*, 23 (2011) 20-21.
- [7] E. Roblegg, E. Jäger, G. Koscher, Continuous manufacturing and hot melt extrusion, APV experts' workshop on hot melt extrusion and its use in the manufacturing of pharmaceutical dosage forms, Tarrytown, NY (USA), (2011 (April 12-13)).
- [8] C. Vervaet, J.P. Remon, Continuous Granulation, in: D.M. Parikh (Ed.) *Handbook of Pharmaceutical Granulation Technology*, Informa Healthcare, New York (USA), 2009, 308-322.
- [9] FDA-Administration, Guidance for Industry - PAT - A Framework for Innovative Pharmaceutical Development, Manufacturing, and Quality Assurance, 2004.
- [10] G. Allison, Y. Cain, C. Cooney, T. Garcia, T. Goen, O. Holt, N. Jagota, B. Komar, E. Korakianiti, D. Kourti, R. Madurawe, E. Morefield, F. Montgomery, M. Nasr, W. Randolph, J.L. Robert, D. Rudd, D. Zezza, Regulatory and quality considerations for continuous manufacturing, in: *Continuous Symposium MIT*, 2014.
- [11] R. Mullin, Pharmaceuticals - Novartis and MIT research continuous manufacturing, *Chemical & Engineering News*, 85 (2007) 10.

- [12] L. Rey, Some leading edge prospects in lyophilization, *American Pharmaceutical Review*, 6 (2003) 32-44.
- [13] L. Pernenkil, C.L. Cooney, A review on the continuous blending of powders, *Chemical Engineering Science*, 61 (2006) 720-742.
- [14] C. Vervaet, J.P. Remon, Continuous granulation in the pharmaceutical industry, *Chemical Engineering Science*, 60 (2005) 3949-3957.
- [15] S. Gotthardt, A. Knoch, G. Lee, Continuous wet granulation using fluidized-bed techniques I. Examination of powder mixing kinetics and preliminary granulation experiments, *European Journal of Pharmaceutics and Biopharmaceutics*, 48 (1999) 189-197.
- [16] M. Jacob, ProCell technology: Modelling and application, *Powder Technology*, 189 (2009) 332-342.
- [17] K. Masters, Process stages and spray drying systems, in: K. Masters (Ed.) *Spray drying in practice*, SprayDryConsult International, Charlottendlund, 2002, 39-96.
- [18] G. Betz, P. Junker-Burgin, H. Leuenberger, Batch and continuous processing in the production of pharmaceutical granules, *Pharmaceutical Development and Technology*, 8 (2003) 289-297.
- [19] J. Werani, M. Grunberg, C. Ober, H. Leuenberger, Semicontinuous granulation - the process of choice for the production of pharmaceutical granules?, *Powder Technology*, 140 (2004) 163-168.
- [20] P.C. Chao, K.J. Steffens, A new continuous high shear granulator, 6th World Meeting on Pharmaceutics, Biopharmaceutics and Pharmaceutical Technology, Barcelona (Spain), (2008).
- [21] B. Van Melkebeke, B. Vermeulen, C. Vervaet, J.P. Remon, Melt granulation using a twin-screw extruder: A case study, *International Journal of Pharmaceutics*, 326 (2006) 89-93.

- [22] E.I. Keleb, A. Vermeire, C. Vervaet, J.P. Remon, Cold extrusion as a continuous single-step granulation and tableting process, *European Journal of Pharmaceutics and Biopharmaceutics*, 52 (2001) 359-368.
- [23] N.R. Trivedi, M.G. Rajan, J.R. Johnson, A.J. Shukla, Pharmaceutical approaches to preparing pelletized dosage forms using the extrusion-spheronization process, *Critical Reviews in Therapeutic Drug carrier systems*, 24 (2007) 1-40.
- [24] J.F. Pinto, C.N. Abreu, Evaluation of the performance of a new continuous spheronizer, *Drug development and industrial pharmacy*, 32 (2006) 1067-1078.
- [25] S.C. Porter, Continuous film coating processes: a review, *Tablets and Capsules*, 4 (2007) 26-29.
- [26] C. Cunningham, J. Hansell, F. Nuneviller, A.R. Rajabi-Siahboomi, Evaluation of recent advances in continuous film coating processes, *Drug development and industrial pharmacy*, 36 (2010) 227-233.
- [27] C. Cahyadi, P.W.S. Heng, L.W. Chan, Optimization of process parameters for a quasi-continuous tablet coating system using design of experiments, *AAPS Pharmscitech*, 12 (2011) 119-131.
- [28] M.M. Crowley, F. Zhang, M.A. Repka, S. Thumma, S.B. Upadhye, S.K. Battu, J.W. McGinity, C. Martin, Pharmaceutical applications of hot-melt extrusion: Part I, *Drug development and industrial pharmacy*, 33 (2007) 909-926.
- [29] M.A. Repka, S.K. Battu, S.B. Upadhye, S. Thumma, M.M. Crowley, F. Zhang, C. Martin, J.W. McGinity, Pharmaceutical applications of hot-melt extrusion: Part II, *Drug development and industrial pharmacy*, 33 (2007) 1043-1057.
- [30] J.P. Lalkshman, Y. Cao, J. Kowalski, A.T.M. Serajuddin, Application of melt extrusion in the development of a physically and chemically stable high-energy amorphous solid dispersion of a poorly water-soluble drug, *Molecular Pharmaceutics*, 5 (2008) 994-1002.

- [31] E. Verhoeven, C. Vervaet, J.P. Remon, Xanthan gum to tailor drug release of sustained-release ethylcellulose mini-matrices prepared via hot-melt extrusion: in vitro and in vivo evaluation, *European Journal of Pharmaceutics and Biopharmaceutics*, 63 (2006) 320-330.
- [32] T. Quinten, T. De Beer, J.P. Remon, C. Vervaet, Overview of injection molding as a manufacturing technique for pharmaceutical applications, in: P.H. Kauffer (Ed.) *Injection molding. Process, design and applications*, Nova Publishers, New York (USA), 2011, 1-41.
- [33] C. Cunningham, J. Gilmour, A. Rajabi-Siahboomi, M. Waldron, T. Page, Investigation of a new semi-continuous coating process using a fully formulated enteric coating system, poster at AAPS, San Antonio (USA), 2013.
- [34] S. Banerjee, N. Bhatwadekar, P. Mahajan, P. Karode, A. Mishra, *Process Analytical Technology (PAT): Boon to pharmaceutical industry*, *Latest reviews*, 6 (2008).
- [35] W. Chew, P. Sharratt, Trends in process analytical technology, *Analytical Methods-UK*, 2 (2010) 1412-1438.
- [36] ICH Q8 Pharmaceutical Development, 2009.
- [37] L.X. Yu, *Pharmaceutical quality by design: Product and process development, understanding, and control*, *Pharmaceutical Research*, 25 (2008) 781-791.



# 1

## **CONTINUOUS TWIN SCREW GRANULATION: INFLUENCE OF PROCESS VARIABLES ON GRANULE AND TABLET QUALITY**

Parts of this chapter are published in:

J. Vercruyse, D. Córdoba Díaz, E. Peeters, M. Fonteyne, U. Delaet, I. Van Assche, T. De Beer, J.P. Remon, C. Vervaet, Continuous twin screw granulation: influence of process variables on granule and tablet quality, *European Journal of Pharmaceutics and Biopharmaceutics* 82 (2012) 205-211.

**Abstract**

The aim of the current study was to screen theophylline (125 mg) tablets manufactured via twin screw granulation in order to improve process understanding and knowledge of process variables which determine granule and tablet quality. A premix of theophylline anhydrate,  $\alpha$ -lactose monohydrate and PVP (ratio: 30/67.5/2.5, w/w) was granulated with demineralized water. Experiments were done using the high shear wet granulation module (based on twin screw granulation) of the ConsiGma™-25 unit (a continuous tablet manufacturing system) for particle size enlargement. After drying, granules were compressed using a MODUL™ P tablet press (compression force: 10 kN, tablet diameter: 12 mm). Using a D-optimal experimental design, the effect of several process variables (throughput (10 - 25 kg/h), screw speed (600 - 950 rpm), screw configuration (number (2, 4, 6 and 12) and angle (30, 60 and 90 degrees) of kneading elements), barrel temperature (25 - 40°C) and method of binder addition (dry vs wet)) on the granulation process (torque and temperature increase of barrel wall), granule (particle size distribution, friability and flowability) and tablet (tensile strength, porosity, friability, disintegration time and dissolution) quality was evaluated. The results showed that the quality of granules and tablets can be optimized by adjusting specific process variables (number of kneading elements, barrel temperature and binder addition method) during a granulation process using a continuous twin screw granulator.

**KEYWORDS:** Continuous wet granulation, Twin screw granulation, Process variables, Granule and tablet quality, Experimental design

## INTRODUCTION

In contrast to other industries (plastics, food, chemistry), the pharmaceutical industry has been reluctant to move from batch processing towards continuous processing for several reasons (e.g. high profit margins, stringent regulatory constraints, limited material volume) [1-3]. However, as many patents of drug molecules recently expired or expire in the near future and due to an increasing demand for solid dosage forms, it is expected that the importance of the concept of continuous production will increase over the coming years [4, 5].

As wet granulation is the most popular method to improve material properties (flow, homogeneity, compressibility) prior to tableting, it is obvious that a continuous wet granulation process is of high importance for a manufacturer of solid dosage forms. Several continuous wet granulation techniques were developed which have been reviewed by Vervaet and Remon [1, 4]. Keleb et al. [6] described the use of a laboratory scale co-rotating twin screw extruder without a die block in order to avoid excessive material densification inside the barrel. In this way, wet granules could be obtained in a continuous manner. Based on this research work [6-9], a twin screw granulator was implemented as the high-shear granulation unit in the commercially available industrial scale ConsiGma<sup>TM</sup>-system (GEA Pharma Systems, Wommelgem, Belgium). This system consists of three modules, as already described by Fonteyne et al. [10] and Chablani et al. [11]: a wet high-shear granulation module, a segmented dryer module and an evaluation module.

Wet granulation via twin screw granulation is an attractive technology for the continuous processing of pharmaceuticals. Twin screw granulators are very flexible in terms of use, offering multiple variables (e.g. screw design, the placement of auxiliary units like feeders and pumps) [12]. Besides, Van Melkebeke et al. [13] successfully demonstrated the possibility to perform melt granulation using the same equipment. However, up-to-now process knowledge (certainly towards specific pharmaceutical formulations) about this innovative manufacturing technique is almost non-existing within the pharmaceutical industry. To improve process understanding, optimize granule quality and increase the process yield, knowledge about the formulation and process variables which determine granule quality is essential. Keleb et al. [8] made a first attempt to modify the screw

configuration. By replacing discharge elements with conveying elements having a longer pitch the compression of the granules was reduced and lower amounts of lumps were generated. Shah [14] used a screw configuration with only conveying and chopping (distributive) elements in order to improve the output and avoid periodic surging of the wet mass as it exited the extruder. Van Melkebeke et al. [7] reported that implementing an extra conveying element after the kneading block improved the granulation yield by reducing the oversized agglomerates. Djuric and Kleinebudde [15] and Thompson and Sun [12] evaluated the impact of different screw elements on continuous granulation with a twin screw extruder. They stated that granule and tablet properties could be influenced by using different designs of screw elements. Dhenge et al. [16] described the influence of screw speed, powder feed rate and liquid-to-solid ratio on the granule properties. In this paper, factors were changed one at a time for each experiment (COST-approach). It was found that alteration of these process variables had a significant impact on the residence time and the average torque during the granulation process, yielding granules with different properties. The liquid-to-solid ratio was recognized as the most influencing factor regarding the granule quality. Djuric and Kleinebudde [17] concluded that for scale-up of continuous twin screw granulation processes the material throughput could not be linearly increased. Further optimization of process variables was needed. In accordance to these results, Dhenge et al. [18] reported that changing the powder feed rate leads to changes in the size, shape, structure, porosity, strength and dissolution time of the granules. Tan et al. [19] used a full-factorial experimental design to describe the effect of granulation liquid composition, injection rate and screw speed on extruder power consumption, granule and tablet properties.

In the current study, an experimental design approach was used to screen theophylline (125 mg) tablets manufactured via twin screw granulation. Design of experiments was used to identify the critical process variables and to study their impact on the granulation process, granule and tablet quality attributes.

## MATERIALS AND METHODS

### Materials

Theophylline anhydrate was purchased from Farma-Química Sur (Malaga, Spain).  $\alpha$ -lactose monohydrate 200M (Caldic, Hemiksem, Belgium) was used as filler for granulation and polyvinylpyrrolidone (PVP) (Kollidon® 30, BASF, Ludwigshafen, Germany) as binder. If PVP was added to the dry premix, distilled water was used as granulation liquid. Magnesium stearate (Fagron, Waregem, Belgium) was applied as lubricant during tableting.

### Preparation of granules

Granulation experiments were performed using a high-shear co-rotating twin screw granulator without die plate, being the granulation unit of the ConsiGma™-25 unit (Fig. 1). The length-to-diameter ratio was 20:1. In the ConsiGma™-25 unit, the granulation unit is directly linked to a six-segmented fluid bed dryer. As the aim of the current study was to improve process understanding of the granulation step, the fluid bed dryer was not used in order to avoid the impact of dynamic drying on the product properties. The barrel of the continuous granulator can be divided into two segments: a feed segment, where powder enters the barrel and consisting of conveying elements to transport the material through the barrel; and a work segment, where the powder is intensively mixed with the granulation liquid by kneading elements [10]. To evaluate the influence of process variables on the granulation process, the torque and temperature of the barrel wall at the work segment of the granulator were recorded. The equipment has an in-built torque gauge. The torque values obtained after equilibration of the process were averaged to give the overall torque during each run. At the work segment, the temperature of the barrel wall was controlled by a Pt100 temperature sensor. As the barrel jacket was not divided into different temperature zones, the full length of the barrel was preheated to equal temperature. During processing, the powder premix was gravimetrically dosed by a twin screw feeder (KT20, K-Tron Soder, Niederlenz, Switzerland). Granulation liquid was gravimetrically pumped into the screw chamber using two peristaltic pumps (Watson Marlow, Comwall, UK) and silicon tubing (internal and external diameter of 1.6 and 4.8 mm, respectively) connected to a 1.6 mm nozzle. Liquid was added in front of the first kneading element. PVP was used as a binder, 2.5% (w/w) in granules, based on dry mass. To evaluate the dissolution properties,

theophylline anhydrate (30%) was added as a model drug to the formulation. The water concentration (9%, calculated on wet mass) was kept constant for all experiments.



Figure 1: Consigma<sup>TM</sup>-25 granulation unit: high-shear twin screw granulator (a) with K-Tron KT20 loss-in-weight feeder (b) and gravimetric liquid addition on both screws (c).

For each run, after equilibration of the system, 800g of wet granules were collected at the outlet of the granulator, spread on a tray and oven-dried at 40°C during 24h. After drying, the total granule batch was divided into two parts of 400g. One part was analysed for particle size distribution as such and the other part was milled through a 1400µm screen at 800rpm using a Quadro comil U10 (Quadro Engineering, Ontario, Canada), which is part of the evaluation module of the ConsiGma<sup>TM</sup>-25 system. The response parameters when investigating the influence of process variables on granule quality were: particle size distributions before and after milling, and friability and flowability of the milled granules.

### Preparation of tablets

Tablets were made using the milled granulation product. Before tableting, the granules were blended with 0.5% (w/w) magnesium stearate in a tumbling mixer (W.A. Bachofen, Basel,

Switzerland). Tablets (417 mg) were prepared using a MODUL™ P tablet press (GEA Pharma Systems, Courtoy™, Halle, Belgium) equipped with a round concave (radius: 24mm) Euro B punch of 12 mm diameter at a compression force of 10 kN per tablet. Tensile strength, porosity, friability, disintegration time and dissolution of the tablets were tested.

### Design of experiments

Preliminary experiments were carried out to determine the experimental ranges for the DOE factors throughput, screw speed and barrel temperature at different number and angle of kneading elements. When 12 kneading elements were used, two kneading zones each consisting of 6 kneading elements had to be used (Fig. 2). Both kneading zones were separated by a conveying element having the same length as one kneading zone. In this way, accumulation of material due to the retaining character of the kneading elements could be limited. An extra conveying element was implemented after the second kneading block in order to reduce the amount of oversized agglomerates, as reported by Van Melkebeke et al. [7]. Nevertheless, as the use of 12 kneading elements at an angle of 90 degrees at different process settings resulted in excessive formation of lumps or even blockage of the system due to excessive friction, this combination of factor levels had to be excluded from the design. For all experiments, the distance between liquid addition and first kneading element was kept constant.

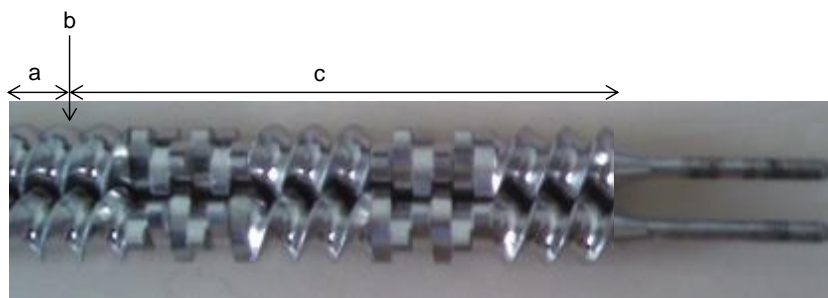

Figure 2: Detail of twin screws with last part of feed segment (a), liquid addition position (b) and work segment (c).

An 18-experiment D-optimal design was used to evaluate the influence of 6 process variables on the granulation process, granule and tablet properties: total throughput (10 - 25 kg/h), screw speed (600 - 900 rpm), screw configuration (number (2, 4, 6 and 12) and angle

(30, 60 and 90 degrees) of kneading elements), barrel temperature (25 - 40°C) and method of binder addition (dry vs wet). D-optimal designs are used for screening and optimization instead of the classical factorial designs when the experimental space is irregular and/or when several (multilevel) qualitative factors are examined, as is the case for this study [20]. Three replicates of the design center point were run. The different factor settings for each run are listed in Table 1. The results were evaluated with MODDE 9.0 software (Umetrics, Umeå, Sweden).

## **Evaluation of granules**

### *Particle size analysis*

Sieve analysis was performed using a Retsch VE 1000 sieve shaker (Haan, Germany). Granules were placed on the shaker during 5 min at an amplitude of 2 mm using a series of sieves (150, 250, 500, 710, 1000, 1400 and 2000  $\mu\text{m}$ ). The amount of granules retained on each sieve was determined. All granule batches were measured in duplicate. The amount of fines and oversized agglomerates were defined as the fractions  $<150$  and  $>1400$   $\mu\text{m}$ , respectively. After milling, the amount of coarse granules was defined as the fraction between 710 and 1400  $\mu\text{m}$ . The yield of the granulation process was defined as the fraction between 150 and 1400  $\mu\text{m}$ .

### *Friability of granules*

The granule friability was determined (n=3) using a friabilator (PTF E Pharma Test, Hainburg, Germany) at a speed of 25 rpm for 10 min, by subjecting 10 g (lwt) of milled granules together with 200 glass beads (mean diameter 4 mm) to falling shocks. Prior to determination, the granule fraction  $<250\mu\text{m}$  was removed to assure the same starting conditions. Afterwards, the glass beads were removed and the weight retained on a 250  $\mu\text{m}$  sieve (Fwt) was determined. The friability was calculated as  $((lwt - Fwt) / lwt)*100$ .



Table 1: Overview of factor settings from the experimental design.

Run	Throughput (kg/h)	Screw speed (rpm)	Kneading elements		Barrel T (°C)	Binder addition
			Number	Angle (°)		
1	17.5	775	4	60	32.5	wet
2	25	600	2	90	25	wet
3	25	950	2	30	40	dry
4	10	600	12	30	40	dry
5	25	600	12	30	40	wet
6	25	950	2	30	25	wet
7	25	600	12	60	25	dry
8	25	950	12	30	25	dry
9	25	600	2	90	40	dry
10	10	600	2	30	25	dry
11	10	950	2	90	25	dry
12	25	950	6	90	40	wet
13	10	950	12	30	25	wet
14	17.5	775	4	60	32.5	wet
15	17.5	775	4	60	32.5	wet
16	10	950	2	30	40	wet
17	10	600	6	90	40	wet
18	10	950	12	60	40	dry

### *Flowability*

The bulk volume ( $V_0$ ) of 30 g milled granules was recorded in a 100 ml measuring cylinder as well as the volume after 1250 taps ( $V_{1250}$ ) in a tapping machine (J. Englesman, Ludwigshafen, Germany) ( $n=3$ ). Bulk and tapped densities were calculated as  $30 \text{ g} / V_0$  and  $30 \text{ g} / V_{1250}$ , respectively. The compressibility index (C%) was calculated from the bulk and tapped density using the following equation,

$$C\% = \{(\rho_f - \rho_i) / \rho_f\} * 100$$

where  $\rho_i$  is the bulk density and  $\rho_f$  is the tapped density.

### **Tablet evaluation**

The hardness, thickness and diameter of tablets ( $n=10$ ) was determined (Sotax HT 10, Basel, Switzerland) after a 24 h storage period at 21 °C and 30% RH. The tablet tensile strength  $T$  was calculated using the equation described by Fell and Newton [21],

$$T = 2 F / \pi d t$$

where  $F$ ,  $d$  and  $t$  denote the diametral crushing force, the tablet diameter and the tablet thickness, respectively. Tablet porosity was calculated ( $n=3$ ) using tablet apparent density and the helium density of the former granules.

The tablet friability was determined ( $n=3$ ) using a friabilator described in Eur. Ph. 5.0. (PTF E Pharma Test, Hainburg, Germany), at a speed of 25 rpm for 4 min. The percentage weight loss was expressed as the tablet friability.

The disintegration time was determined ( $n=6$ ) using the apparatus described in Eur. Ph. 5.0. (PTZ-E Pharma Test, Hainburg, Germany). Tests were performed in distilled water at  $37 \pm 0.5$  °C using disks.

Dissolution tests were performed ( $n=3$ ) in 900 ml demineralised water ( $\text{pH} = 5$ ) using the paddle method (VK 7010, Vankel, Cary, NC, USA). The temperature of the dissolution medium was maintained at  $37 \pm 0.5$  °C, while the rotation speed was set at 50 rpm. 5 ml samples were withdrawn at 5, 10, 15, 20, 30, 45 and 60 min after starting the dissolution.

The drug content was determined at 272 nm using an UV-1650PC double beam spectrophotometer (Shimadzu Benelux, Antwerp, Belgium).

## RESULTS AND DISCUSSION

### Evaluation of granulation process

Generally, conveying elements are used in a screw design to move material with minimal mechanical energy imparted, while kneading elements intensively mix solid and liquid components during continuous wet granulation. Kneading elements operate fully filled with material and may be partially or fully dependent on pressure-driven flow, as described by Thompson and Sun [12]. Because of their retaining character for the mass flow through the barrel, increasing the number of kneading elements led to more friction inside the barrel and consequently higher torque values (Fig. 3). As the granulation process generates friction and heat, the temperature of the barrel wall at the work segment of the granulator was monitored during each run. Using more kneading elements caused a higher temperature increase at the barrel wall (0.0 to 21.5°C) (Table 2) as a result of the higher amount of heat generated by friction. If the level of barrel temperature was low (25°C) and a higher number of kneading elements was used, the contribution of the heat generated by friction to the temperature of the barrel wall during processing was high (e.g. run 7, 8 and 13).

Increasing the throughput (kg/h) resulted in a higher filling degree which required more energy input to rotate the screws at the predefined screw speed, yielding higher torque values (Fig. 3). In contrast to Tan et al. [19], no significant impact of screw speed on torque was observed. In the current study, the screw speed was varied between 600 and 950 rpm. As the difference of screw load at lower versus higher screw speed is low, no significant differences in extent of shear and compaction forces experienced by the material inside the barrel were observed. Changing the angle of kneading elements or the binder addition method had no significant effect on torque. As described above, the combination of 12 kneading elements at an angle of 90 degrees was excluded from the design due to the formation of lumps or even blockage of the system. It seems that the angle of kneading elements only becomes an important factor when a higher amount of kneading elements is used.

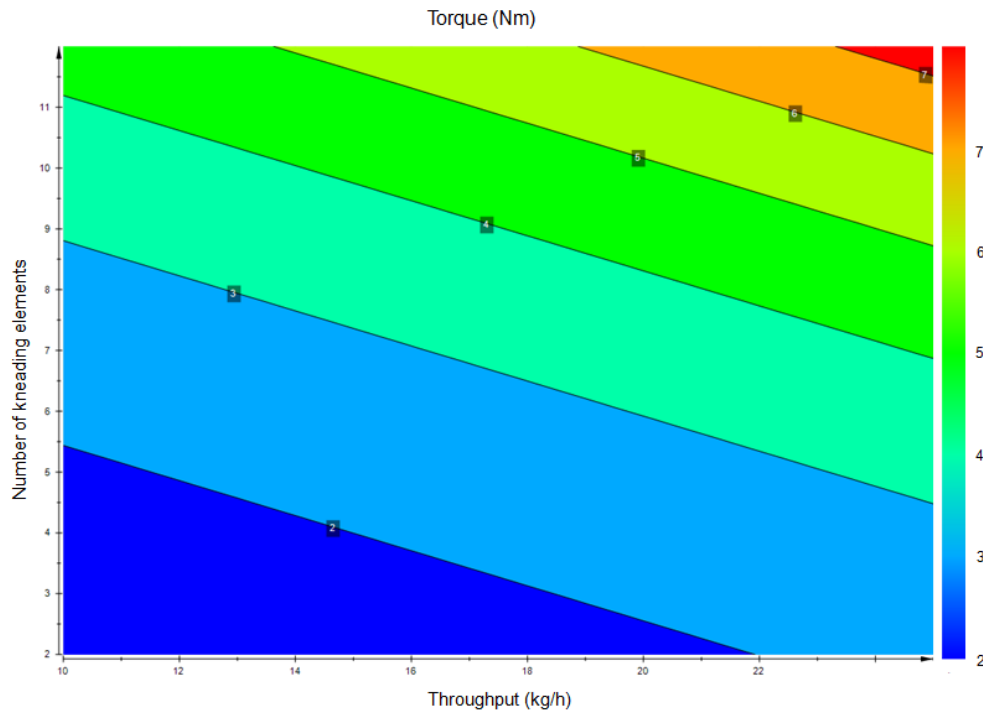

Figure 3: Contour plot for torque as a function of throughput (kg/h) and number of kneading elements.

During start-up of each run, the torque and temperature of the barrel wall increased until equilibrium was reached. This can be explained by the gradual layering of the barrel wall at the work segment with wet mass during this phase. The time needed for the torque and temperature of barrel wall to equilibrate gives a good indication of the time needed for the granulation process to reach steady state conditions. It was found that when a higher number of kneading elements was used, the time to reach equilibrium was higher (0 to 9 min) (Table 2). Using a feedback control system material loss during start-up can be minimized. This system regulates the temperature of the barrel jacket during the granulation process in order to compensate for the temperature increase of the barrel wall due to friction.

Table 2: Characterization of granulation process and granules from the experimental design.

Run	Process			Unmilled granules			Milled granules				
	Torque (Nm)	Barrel T increase (°C)	Time to steady state (sec)	<150µm (%)	150-1400µm (%)	>1400µm (%)	<150µm (%)	710-1400µm (%)	150-1400µm (%)	Friability (%)	Compressibility (%)
1	1.5	0.0	250	6.6	51.1	42.2	29.3	18.5	70.7	8 ± 0	8 ± 1
2	2.2	0.0	100	20.2	48.8	30.9	45.0	13.0	55.0	10 ± 1	10 ± 1
3	2.1	0.0	25	10.8	55.8	33.3	35.2	15.0	64.8	7 ± 0	12 ± 1
4	4.0	10.0	350	1.3	41.3	57.5	15.7	30.9	84.3	3 ± 0	10 ± 3
5	7.3	10.3	335	0.9	33.7	65.4	15.3	33.2	84.7	3 ± 0	8 ± 1
6	2.4	0.4	165	11.3	47.1	41.5	33.9	20.1	66.1	9 ± 1	7 ± 1
7	5.6	12.5	285	11.2	60.0	28.8	29.3	19.1	70.7	2 ± 0	8 ± 0
8	6.6	21.5	535	1.8	43.6	54.6	17.9	28.1	82.1	9 ± 1	9 ± 1
9	1.9	0.0	35	16.5	51.4	32.1	36.6	16.8	63.4	11 ± 1	9 ± 1
10	1.3	0.3	60	14.6	57.7	27.7	34.1	18.2	65.9	9 ± 0	10 ± 0
11	0.9	0.1	45	19.0	61.5	19.5	37.6	15.6	62.4	9 ± 0	9 ± 1
12	4.9	6.2	250	1.0	16.7	82.3	18.2	28.6	81.8	1 ± 0	9 ± 0
13	4.5	20.2	335	2.4	46.2	51.4	19.5	28.1	80.5	4 ± 0	7 ± 1
14	1.7	0.1	215	8.7	51.8	39.5	31.1	17.6	68.9	7 ± 1	10 ± 1
15	1.4	0.0	275	11.0	54.4	34.6	33.3	17.0	66.7	7 ± 0	9 ± 1
16	1.3	0.0	200	7.6	53.9	38.5	27.4	20.0	72.6	5 ± 0	10 ± 1
17	4.4	6.0	300	1.6	52.4	46.1	17.2	27.7	82.8	3 ± 0	7 ± 2
18	2.8	8.5	385	2.4	53.4	44.2	17.9	26.7	82.1	3 ± 0	9 ± 0

### **Influence of process variables on granule quality**

Particle size distributions of granules before and after milling were determined. A significant relationship between amount of fines and amount of oversized agglomerates and three process variables was detected: number of kneading elements, barrel temperature and binder addition method (Fig. 4a and b). By increasing the number of kneading elements, the powder was more intensively mixed with the granulation liquid, yielding less fines (0.9 to 20.2% <150 $\mu$ m) and more oversized agglomerates (19.5 to 82.3% >1400 $\mu$ m) (Table 2). This was also described by Thompson and Sun [12] and Djuric and Kleinebudde [15]. The same effects on particle size distribution were observed at a higher barrel temperature due to an increased solubility rate of the powder mixture in the granulation liquid.

Because of the low residence time during twin screw granulation, the binder was more effective when it was already dissolved in the granulation liquid. Although changing the throughput led to different degrees of barrel filling and torque values, no significant impact on the particle size distribution was detected. No significant effect for angle of kneading elements and screw speed on particle size distribution was found. According to Thompson and Sun [12], the angle of kneading elements only affected the particle size distribution if the filling degree of the barrel was high (70%). Dhenge et al. [16] already mentioned the minimal effect of screw speed on the size of the granules.

As the same process variables had an opposite effect on the amount of fines and the amount of oversized agglomerates (Fig. 4a and b), the changes in yield before milling could not be explained by the variation of a specific process variable. Milling of the granules resulted in breakage of oversized agglomerates and extra formation of fines (19.2  $\pm$  3.4%). As a higher number of kneading elements and barrel temperature led to less fines before milling, as already described above, and a lower increase of fines by milling, the process yield after milling could be increased (55.0 to 84.7%) by adjusting these process variables (Fig. 5).

a

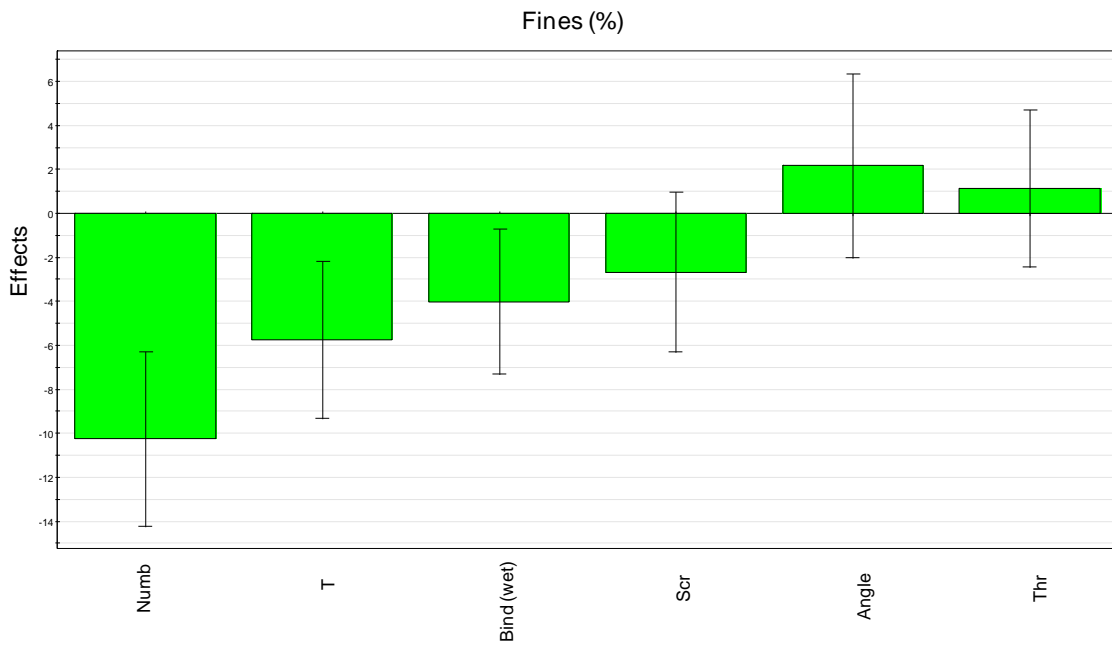

b

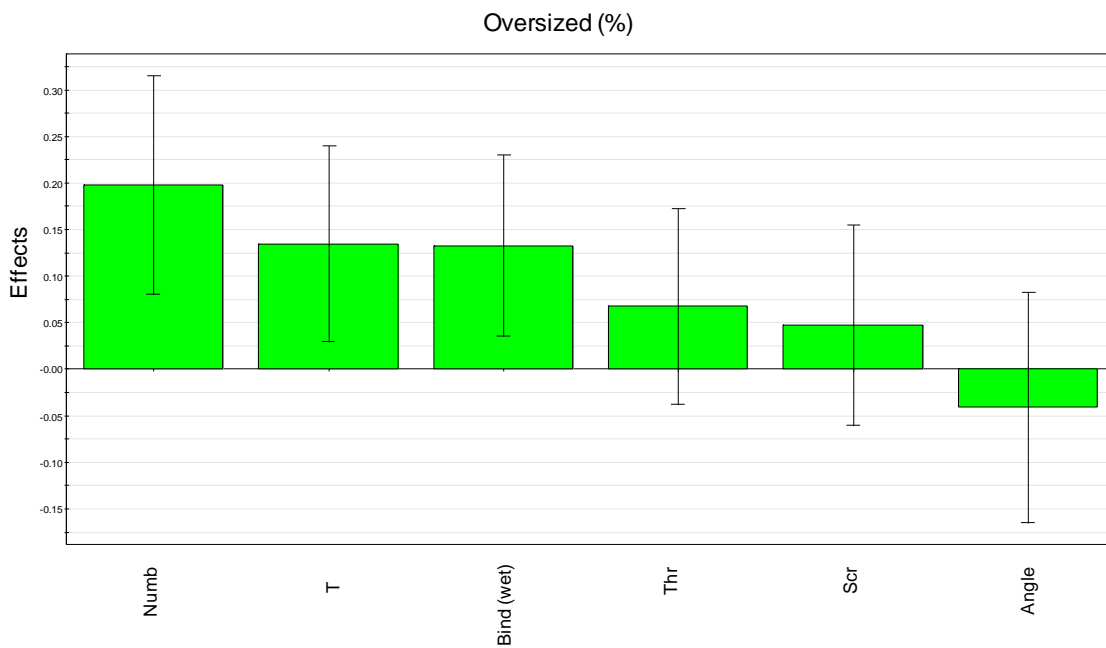

Figure 4: Effect plots for particle size distribution of granules before milling: fines (a) and oversized agglomerates (b). Numb: Number of kneading elements; T: Barrel temperature; Bind (wet): Binder addition via granulation liquid; Scr: Screw speed; Angle: Angle of kneading elements; Thr: throughput.

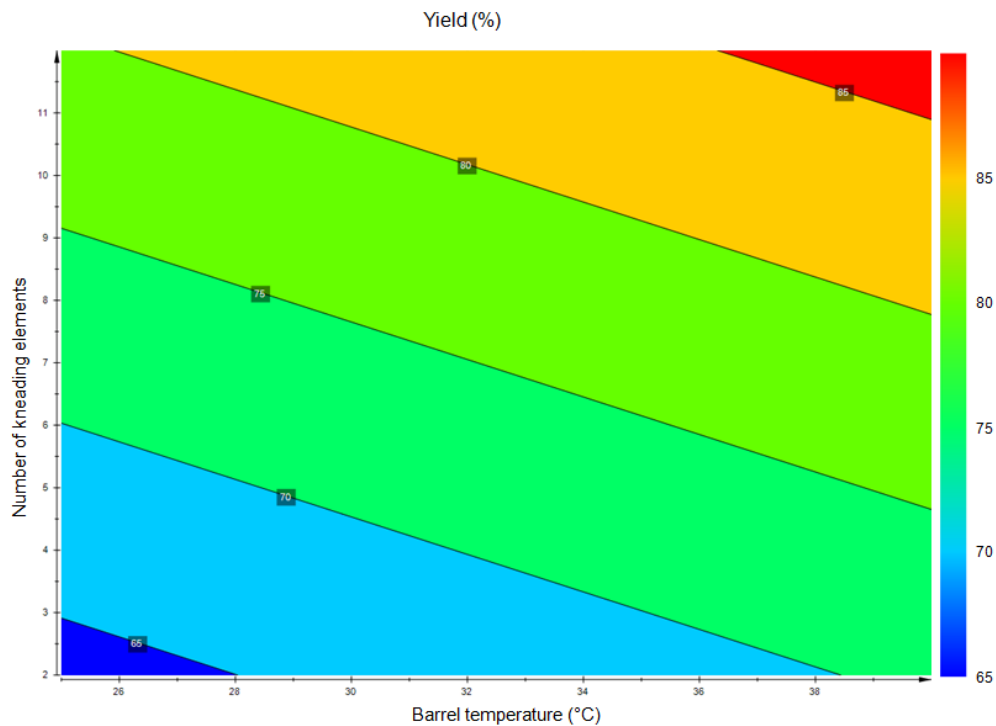

Figure 5: Contour plot for yield (150-1400 $\mu$ m) of milled granules as a function of barrel temperature ( $^{\circ}$ C) and number of kneading elements.

For all granules, the friability, an estimate for granule strength, was low (1 to 11%). However, using more kneading elements and higher barrel temperature yielded less friable granules (Fig. 6). Kneading elements improved the distribution of granulation liquid through the powder bed and densified the material, resulting in stronger granules which are less liable to mechanical stress [7]. Besides, by increasing the barrel temperature, more theophylline and lactose dissolved in the granulation liquid which formed solid bridges after recrystallisation during drying.

The results for bulk and tapped density are shown in Fig. 7. The bulk densities ranged from 0.55 to 0.67 g/ml, and the tapped densities from 0.63 to 0.73 g/ml. The number of kneading elements significantly affected granule bulk and tapped density. Increasing the number of kneading elements resulted in higher bulk and tapped densities. When a higher number of kneading elements were used more irregular shaped coarse granules were formed, in agreement with Thompson and Sun [12], leading to a better packing of the granules when poured into the cylinder. The compressibility index was used to describe the flowability of the granules. Compressibility indices marginally differed from each other and did not exceed



15%, indicating a good flowability of the granules [22]. No significant relationships between the flow properties and any of the process variables were detected.

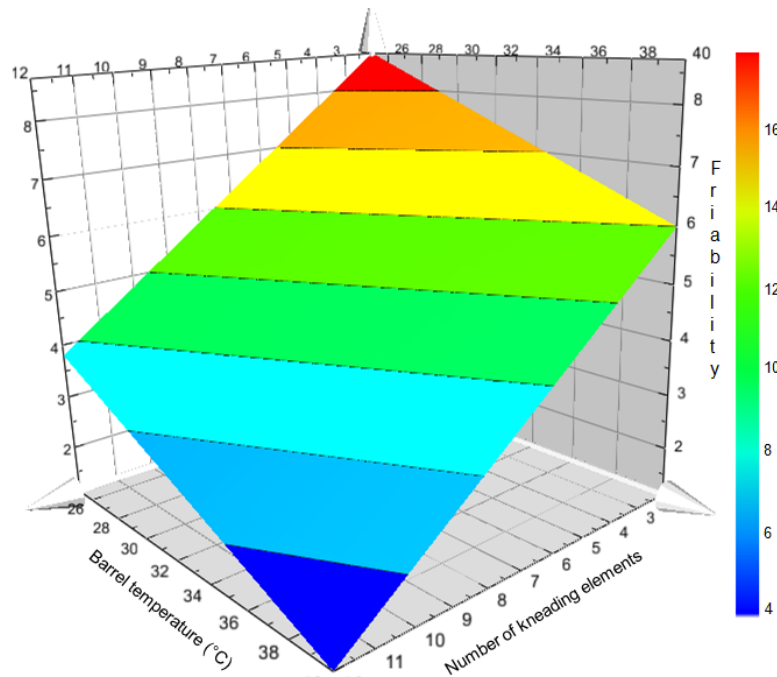

Figure 6: Surface plot for friability of milled granules as a function of barrel temperature (°C) and number of kneading elements.

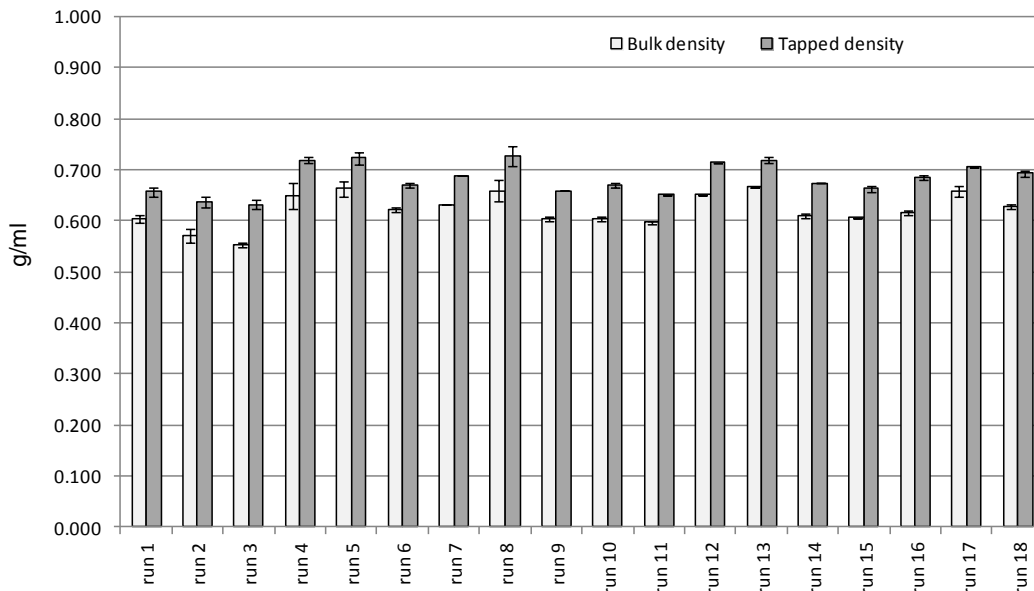

Figure 7: Bulk and tapped densities of milled granules.

### **Influence of process variables on tablet quality**

Tablets were made from the milled fraction of the granules. No extragranular disintegrant was added to the formulation in order to avoid the loss of significant relationships between process variables and tablet properties. In accordance to Djuric and Kleinebudde [15], shortening of the kneading section during twin screw granulation yielded granules with a lower density. Compression of these granules resulted in tablets with a higher tensile strength (1.24 to 1.78 MPa) (Table 3) due to the lower resistance towards deformation during compression.

For all tablets, the friability was low (0.17 to 0.30%). However, barrel temperature had statistically significant impact on the tablet friability. A higher barrel temperature during granulation resulted in tablets with a lower friability. Regarding the porosity of the tablets (19.1 to 24.8%), no significant process variables were detected.

The use of more kneading elements during granulation created granules with a higher density [15]. Because of the increased density, the percolation of liquids inside these granules is hampered resulting in tablets with a higher disintegration time (470 to 1256 sec). Besides, elongation of the kneading zone during granulation decreased the amount of fines, which are important for disintegration.

Next to the disintegration time, it was investigated if process variables could significantly influence the drug release profile, as this is the most important characteristic for tablets. As the aim of this study was to compare drug release profiles of tablets made from granules produced with different process settings, no disintegrant was added to the formulation. Again, the number of kneading elements showed a significant impact on the dissolution results (Fig. 8). Similar to the disintegration results, tablets made from denser granules (i.e. higher number of kneading elements) showed a slower drug release profile (69.8 to 86.6% released after 45min). These results were in agreement with the conclusions made by Dhenge et al. [18]. In this paper, it was noticed that at increased powder feed rate denser granules were produced which took longer time to release the salt embedded in them.

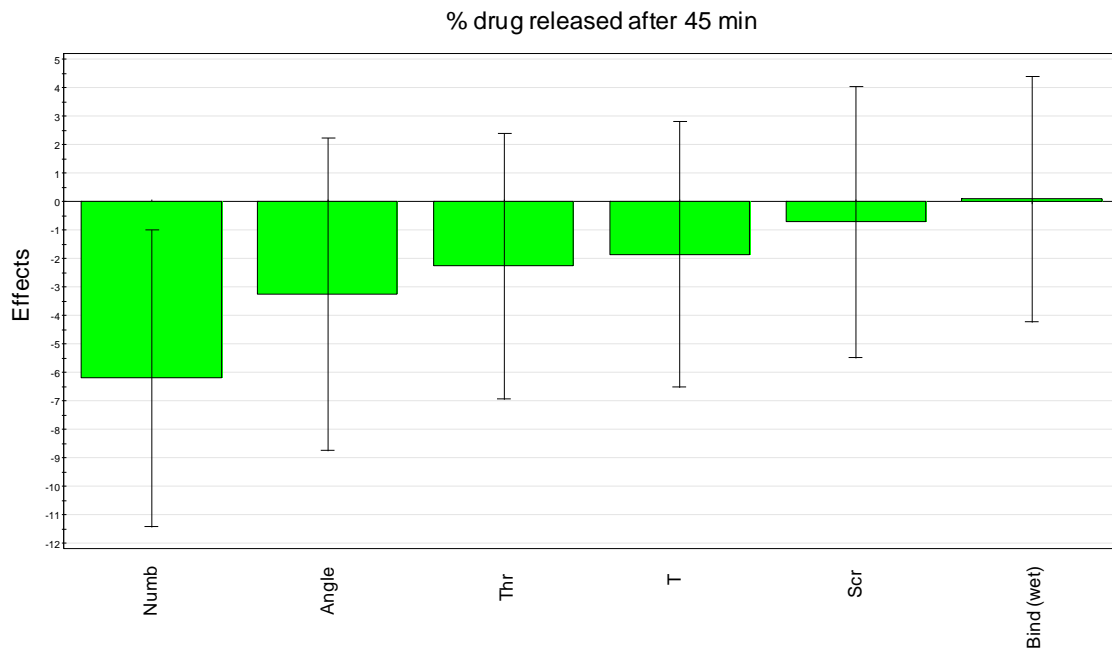

Figure 8: Effect plot for percentage drug released after 45 min. Numb: Number of kneading elements; Angle: Angle of kneading elements; Thr: throughput; T: Barrel temperature; Scr: Screw speed; Bind (wet): Binder addition via granulation liquid.

Table 3: Characterization of tablets from the experimental design.

Run	Tensile strength (MPa)	Porosity (%)	Friability (%)	Disintegration time (s)	% release after 45 min
1	1.78 ± 0.04	19.0 ± 2.1	0.25	772 ± 80	73.8 ± 3.1
2	1.48 ± 0.06	15.2 ± 1.9	0.30	730 ± 66	76.8 ± 4.3
3	1.57 ± 0.09	17.9 ± 0.5	0.26	828 ± 25	73.7 ± 5.6
4	1.32 ± 0.05	16.0 ± 1.9	0.24	927 ± 49	72.2 ± 2.1
5	1.36 ± 0.05	19.4 ± 1.0	0.23	649 ± 45	71.1 ± 2.2
6	1.43 ± 0.06	19.0 ± 0.8	0.26	605 ± 75	73.9 ± 1.9
7	1.45 ± 0.04	16.1 ± 1.1	0.27	774 ± 44	74.0 ± 2.0
8	1.24 ± 0.06	16.9 ± 1.1	0.23	766 ± 57	77.8 ± 5.5
9	1.52 ± 0.06	17.2 ± 1.2	0.22	834 ± 59	73.4 ± 4.8
10	1.52 ± 0.08	15.7 ± 1.0	0.27	470 ± 50	82.1 ± 6.0
11	1.61 ± 0.06	18.8 ± 0.2	0.26	529 ± 59	77.4 ± 1.4
12	1.54 ± 0.07	17.5 ± 0.3	0.19	825 ± 108	71.9 ± 4.4
13	1.27 ± 0.08	16.6 ± 0.6	0.23	938 ± 78	70.9 ± 3.5
14	1.52 ± 0.04	20.1 ± 0.7	0.21	536 ± 43	81.7 ± 1.7
15	1.51 ± 0.05	19.6 ± 0.9	0.19	557 ± 37	76.5 ± 1.3
16	1.63 ± 0.07	19.9 ± 1.1	0.21	485 ± 62	86.6 ± 3.4
17	1.35 ± 0.09	17.9 ± 0.9	0.19	765 ± 61	73.1 ± 6.0
18	1.44 ± 0.08	18.4 ± 0.4	0.17	1256 ± 49	69.8 ± 3.7

## CONCLUSIONS

This study was designed to screen theophylline (125mg) tablets manufactured via twin screw granulation. Using a D-optimal experimental design, the effect of several process variables on the granulation process, granule and tablet quality was evaluated. No significant relationships for angle of kneading elements and screw speed were found. Increased throughput and number of kneading elements resulted in higher torque values during granulation. More friction due to elongation of the kneading zone resulted in a higher temperature increase of the barrel wall. A higher number of kneading elements and barrel temperature resulted in less fines, more oversized agglomerates and less friable granules. As barrel temperature had an important effect on the granule properties, this parameter should be carefully controlled, especially when using good water soluble components e.g. lactose. Because of the short residence time during twin screw granulation, the binder was more effective when it was already dissolved in the granulation liquid. The tensile strength, disintegration time and dissolution profile of tablets depended on the number of kneading elements. Increasing the number of kneading elements yielded denser granules which were less deformable during compression. Percolation of liquids inside these granules is hampered, resulting in tablets with a longer disintegration time and a slower drug release. The results showed that the quality of granules and tablets can be optimized by adjusting specific process variables (number of kneading elements, barrel temperature and binder addition method) during a granulation process using a continuous twin screw granulator.

## REFERENCES

- [1] C. Vervaet, J.P. Remon, Continuous Granulation, in: D.M. Parikh (Ed.) Handbook of Pharmaceutical Granulation Technology, Informa Healthcare, New York (USA), 2009, 308-322.
- [2] H. Leuenberger, New trends in the production of pharmaceutical granules: batch versus continuous processing, European Journal of Pharmaceutics and Biopharmaceutics, 52 (2001) 289-296.
- [3] FDA-Administration, Guidance for Industry - PAT - A Framework for Innovative Pharmaceutical Development, Manufacturing, and Quality Assurance, 2004.
- [4] C. Vervaet, J.P. Remon, Continuous granulation in the pharmaceutical industry, Chemical Engineering Science, 60 (2005) 3949-3957.
- [5] M. Lodaya, M. Mollan, I. Ghebre-Sellassie, Twin-screw Wet Granulation, in: I. Ghebre-Sellassie, C. Martin (Eds.) Pharmaceutical Extrusion Technology, Informa Healthcare, New York (USA), 2003, 323-343.
- [6] E.I. Keleb, A. Vermeire, C. Vervaet, J.P. Remon, Continuous twin screw extrusion for the wet granulation of lactose, International Journal of Pharmaceutics, 239 (2002) 69-80.
- [7] B. Van Melkebeke, C. Vervaet, J.P. Remon, Validation of a continuous granulation process using a twin-screw extruder, International Journal of Pharmaceutics, 356 (2008) 224-230.
- [8] E.I. Keleb, A. Vermeire, C. Vervaet, J.P. Remon, Twin screw granulation as a simple and efficient tool for continuous wet granulation, International Journal of Pharmaceutics, 273 (2004) 183-194.
- [9] D. Djuric, B. Van Melkebeke, P. Kleinebudde, J.P. Remon, C. Vervaet, Comparison of two twin-screw extruders for continuous granulation, European Journal of Pharmaceutics and Biopharmaceutics, 71 (2009) 155-160.

- [10] M. Fonteyne, J. Vercruyssen, D.C. Díaz, D. Gildemyn, C. Vervaet, J.P. Remon, T.D. Beer, Real-time assessment of critical quality attributes of a continuous granulation process, *Pharmaceutical Development and Technology*, 18 (2013) 85-97.
- [11] L. Chablani, M.K. Taylor, A. Mehrotra, P. Rameas, W.C. Stagner, Inline real-time near-infrared granule moisture measurements of a continuous granulation–drying–milling process, *AAPS PharmSciTech*, 12 (2011) 1050-1055.
- [12] M.R. Thompson, J. Sun, Wet Granulation in a twin-screw extruder: implications of screw design, *Journal of pharmaceutical sciences*, 99 (2010) 2090-2103.
- [13] B. Van Melkebeke, B. Vermeulen, C. Vervaet, J.P. Remon, Melt granulation using a twin-screw extruder: A case study, *International Journal of Pharmaceutics*, 326 (2006) 89-93.
- [14] U. Shah, Use of a modified twin-screw extruder to develop a high-strength tablet dosage form, *Pharmaceutical Technology*, 6 (2005) 52-66.
- [15] D. Djuric, P. Kleinebudde, Impact of screw elements on continuous granulation with a twin-screw extruder, *Journal of pharmaceutical sciences*, 97 (2008) 4934-4942.
- [16] R.M. Dhenge, R.S. Fyles, J.J. Cartwright, D.G. Doughty, M.J. Hounslow, A.D. Salman, Twin screw wet granulation: Granule properties, *Chemical Engineering Journal*, 164 (2010) 322-329.
- [17] D. Djuric, P. Kleinebudde, Continuous granulation with a twin-screw extruder: Impact of material throughput, *Pharmaceutical Development and Technology*, 15 (2010) 518-525.
- [18] R.M. Dhenge, J.J. Cartwright, D.G. Doughty, M.J. Hounslow, A.D. Salman, Twin screw wet granulation: Effect of powder feed rate, *Advanced Powder Technology*, 22 (2011) 162-166.
- [19] L. Tan, A.J. Carella, Y.K. Ren, J.B. Lo, Process optimization for continuous extrusion wet granulation, *Pharmaceutical Development and Technology*, 16 (2011) 302-315.
- [20] L. Eriksson, E. Johansson, N. Kettaneh-Wold, C. Wikström, S. Wold, *Design of Experiments - principles and applications*, MKS Umetrics AB, Umeå (Sweden), 2008.

[21] J.T. Fell, J.M. Newton, Determination of tablet strength by diametral-compression test, *Journal of pharmaceutical sciences*, 59 (1970) 688-691.

[22] A.M. Railkar, J.B. Schwartz, Evaluation and comparison of a moist granulation technique to conventional methods, *Drug development and industrial pharmacy*, 26 (2000) 885-889.



# 2

## **VISUALIZATION AND UNDERSTANDING OF THE GRANULATION LIQUID MIXING AND DISTRIBUTION DURING CONTINUOUS TWIN SCREW GRANULATION USING NIR CHEMICAL IMAGING**

Parts of this chapter are published in:

J. Vercruyse, M. Toiviainen, M. Fonteyne, N. Helkimo, J. Ketolainen, M. Juuti, U. Delaet, I. Van Assche, J.P. Remon, C. Vervaet, T. De Beer, Visualization and understanding of the granulation liquid mixing and distribution during continuous twin screw granulation using NIR chemical imaging, *European Journal of Pharmaceutics and Biopharmaceutics* 86 (2014) 383-392.

### **Abstract**

Over the last decade, there has been increased interest in the application of twin screw granulation as a continuous wet granulation technique for pharmaceutical drug formulations. However, the mixing of granulation liquid and powder material during the short residence time inside the screw chamber and the atypical particle size distribution (PSD) of granules produced by twin screw granulation is not yet fully understood. Therefore, this study aims at visualizing the granulation liquid mixing and distribution during continuous twin screw granulation using NIR chemical imaging. In first instance, the residence time of material inside the barrel was investigated as function of screw speed and moisture content followed by the visualization of the granulation liquid distribution as function of different formulation and process parameters (liquid feed rate, liquid addition method, screw configuration, moisture content and barrel filling degree). The link between moisture uniformity and granule size distributions was also studied.

For residence time analysis, increased screw speed and lower moisture content resulted to a shorter mean residence time and narrower residence time distribution. Besides, the distribution of granulation liquid was more homogenous at higher moisture content and with more kneading zones on the granulator screws. After optimization of the screw configuration, a two-level full factorial experimental design was performed to evaluate the influence of moisture content, screw speed and powder feed rate on the mixing efficiency of the powder and liquid phase. From these results, it was concluded that only increasing the moisture content significantly improved the granulation liquid distribution.

This study demonstrates that NIR chemical imaging is a fast and adequate measurement tool for allowing process visualization and hence for providing better process understanding of a continuous twin screw granulation system.

**KEYWORDS:** Twin screw granulation, Granulation liquid distribution, NIR chemical imaging, Process understanding

## INTRODUCTION

Traditionally, the manufacturing of pharmaceutical dosage forms has been via batch-wise production. However, several important economic factors related to product quality, production costs and time-to-market stimulated the introduction of continuous pharmaceutical production. As a result, several equipment manufacturers have identified the specific needs for continuous production processes within the pharmaceutical industry. In this context, GEA Pharma Systems recently launched the ConsiGma™-25 system (GEA Pharma Systems, Wommelgem, Belgium) which is a continuous ‘from powder to tablet’ manufacturing system. This system uses continuous twin screw granulation as an intermediate wet granulation step in order to improve the raw material properties (i.e. flow, compressibility, homogeneity, etc.) before tableting. Over the last decade, several research groups contributed to the body of knowledge about twin screw technology as a tool for continuous pharmaceutical granulation. A major advantage of twin screw granulation is the flexibility in design and output capacity, allowing development work as well as production on the same apparatus [1].

However, to fully benefit from the advantages of continuous manufacturing, real-time release of products instead of time-consuming post production analysis is desired. Therefore, process analytical technology (PAT) tools need to be implemented for process visualization (process understanding) and for the monitoring of critical (intermediate) quality attributes. Several researchers already described the use of NIR as an in-line measurement tool for a continuous twin screw granulation-drying-milling process. Fonteyne et al. [2] gave an insight in the possibilities of implementing PAT tools in a continuous twin-screw granulation process and concluded that NIR was an appropriate tool for the monitoring of the solid state and moisture content of the granules. Chablani et al. [3] used in-line real-time NIR measurements to monitor the residual moisture content after fluid bed drying of granules produced by twin screw granulation.

Whereas the granulation mechanisms for conventional batch granulation techniques (i.e. fluid bed granulation, high-shear granulation) have been unraveled, the fundamentals of agglomerate formation during the short residence time of the material inside a twin screw granulator still needs to be elucidated [4-9]. This information, in combination with the

knowledge about the effect of the different process and formulation variables upon the granule properties, should allow to efficiently design a continuous granulation process based on the characteristics of the formulation and the requirements of the end product. Moreover, as twin screw granulation is an inherently regime-separated granulator, where wetting, nucleation, consolidation and growth are supposed to be separated, a better control of the granule quality attributes should be reached [10-12]. Furthermore, Dhenge et al. [13] recently published a study on the progression of granules (wetting and nucleation, consolidation and growth, and breakage and attrition) in different compartments along the length of the screws in a twin screw granulator, helping to provide a better understanding of the twin screw granulation process. However, the mixing of granulation liquid and powder material and the resulting distribution of granulation liquid inside the wet granules produced by twin screw granulation is not yet fully understood. Besides, it is not clear what the origin is of the typical bimodal particle size distribution observed for granules produced by twin screw granulation [14-21]. Shah et al. [18] compared dual-port injection and single-port injection of granulation liquid into the barrel and concluded that dual-port injection resulted in a lower and more stable torque on the screw shafts because of the better distribution of granulation liquid within the granulator. Changing the proportion of injection at the first injection port and the second injection port did not alter output, torque or granule characteristics. Besides, it was stated that in contrast to batch high-shear granulation where the transport distances to the moving elements and the walls is large, short mass-transfer distances should promote accurate distribution of formulation constituents. El Hagrasy et al. [10] concluded that granules produced by twin screw granulation showed a broad granule size distribution and lump formation even at low liquid levels, likely due to uneven liquid distribution inside the granulator. A narrower particle size distribution was obtained at higher liquid content, in agreement with Dhenge et al [22]. However, particle sizes ( $d_{50} > 1500\mu\text{m}$ ) were well beyond the usable size range for downstream processing of granules in the pharmaceutical industry. Generating a smaller and more narrow granule size distribution is desired as this would improve the drying uniformity and reduce the risk of segregation during downstream processing. Furthermore, El Hagrasy et al. [10] stated that it is important to gather insight into the liquid distribution of granules produced by twin screw granulation, as this predominantly determines the granule size distribution.

The aim of the current study was to visualize and understand the granulation liquid mixing and distribution during continuous twin screw granulation using NIR chemical imaging. NIR chemical imaging was used to investigate the residence time of material inside the barrel and the granulation liquid distribution of the wet granules as a function of formulation and process parameters (liquid feed rate, liquid addition method, screw configuration, moisture content and barrel filling degree). Furthermore, it was examined whether there is a link between the granulation liquid distribution and the particle size distribution of the granules.

## **MATERIALS AND METHODS**

### **Materials**

$\alpha$ -Lactose monohydrate (Pharmatose 200M, Caldic, Hemiksem, Belgium) was used as a model excipient. Distilled water was added as granulation liquid. To evaluate the residence time of material inside the barrel, theophylline anhydrate ( $d_{50} = 40.1 \mu\text{m}$ ) (Farma-Química Sur, Malaga, Spain) was used as tracer molecule.

### **Continuous twin screw granulation**

Granulation experiments were performed using a high-shear co-rotating twin screw granulator without die plate, being the granulation module of the ConsiGma<sup>TM</sup>-25 unit (GEA Pharma Systems, Wommelgem, Belgium) (Fig. 1). The ConsiGma<sup>TM</sup>-25 system consists of three modules, as already described by Chablani et al. [3] and Fonteyne et al. [2]: a high-shear wet granulation module, a six-segmented fluid bed dryer module and a granule conditioning module. As the aim of the current study was to improve process understanding of the granulation step, only the granulation module was used. The length-to-diameter ratio of the granulator is 20:1. The screw barrel is divided into two segments: a feed segment, where powder enters the barrel and consisting of conveying elements to transport the material through the barrel; and a work segment, where the powder is intensively mixed with the granulation liquid by kneading elements [2, 21]. As the barrel jacket was not divided into different temperature zones, the full length of the barrel was preheated to equal temperature (25 °C). During processing, pure  $\alpha$ -lactose monohydrate was gravimetrically dosed by a twin screw feeder (KT20, K-Tron Soder, Niederlenz, Switzerland). Distilled water as granulation liquid was gravimetrically pumped into the screw chamber by using two

peristaltic pumps (Watson Marlow, Comwall, UK) and silicon tubings connected to 1.6 mm nozzles (unless otherwise specified). Liquid was added in front of the first kneading element by dripping through two liquid feed ports, each port located on the central top of each screw.

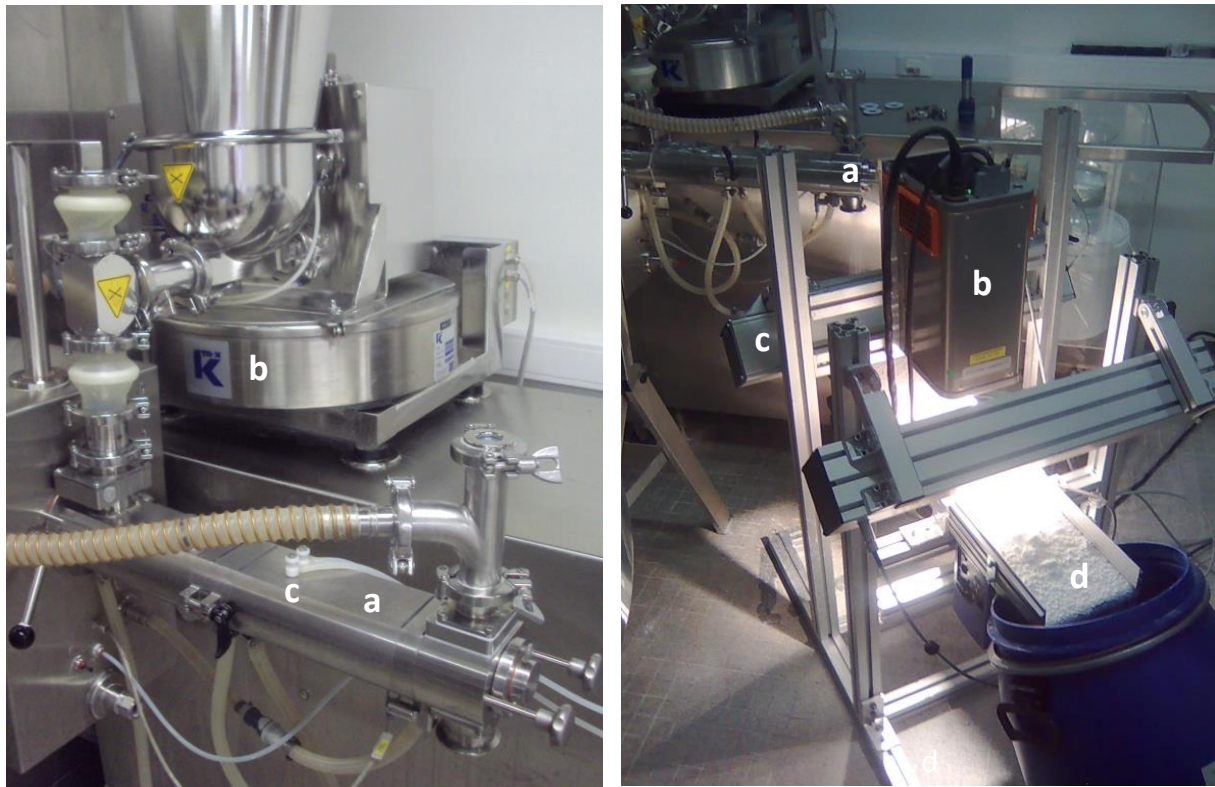

Figure 1: Left: Consigma<sup>TM</sup>-25 granulation unit: high-shear twin screw granulator (a) with K-Tron KT20 loss-in-weight feeder (b) and gravimetric liquid addition on both screws (c). Right: Representation of measurement set-up: outlet of granulator (a), spectral camera (b), halogen lamps (c) and conveyor belt for sampling scanning (d).

### Description of NIR chemical imaging system and measurement setup

Spectral images of the continuously produced wet granules were collected using a line-scanning (pushbroom) hyperspectral camera (SWIR, Specim Ltd., Oulu, Finland). The camera sees a row of 320 spatial pixels at a time, and it disperses the incoming light from each pixel in the spectral range 970-2500 nm onto one column on the 320×256-pixel mercury-cadmium-telluride (MCT) detector (14-bit readout, cooled to -70°C with a 4-stage Peltier system). The continuously produced wet granules fell from the granulator output onto a conveyor belt (Mini, ENP, Hjärteby, Sweden) which was moving at a speed of 3.12 cm/s. The

camera was placed above the belt and the camera-to-belt distance was set such that the imaged line had a length of 10 cm on the conveyor belt, and the speed of the conveyor belt was adjusted such that the geometry was preserved – i.e. spatial pixels were squares of the size  $312 \times 312 \mu\text{m}^2$  – at the maximum frame rate permitted by the camera (100 frames per second). The conveyor belt and the continuously produced granules on it were illuminated with two rows of five 75-W halogen lamps (Specim Ltd., Oulu, Finland), and the measurement was conducted in diffuse reflectance mode in the  $45^\circ\text{-}0^\circ\text{-}45^\circ$  geometry (Fig. 1). Each collected spectral image consisted of 2500 frames (25-s measurement,  $2500 \times 320$  spatial pixels, 256-element spectrum at each spatial pixel) which corresponds to an area of  $10 \times 78 \text{ cm}^2$  on the conveyor belt. At a powder feed rate of 20 kg/h, the dry mass of material in one spectral image was approximately 170 g.

### **Extraction of relevant information from chemical images**

The processing of the hyperspectral images consisted of two phases. First, spatial pixels corresponding to the plastic conveyor belt were eliminated from the analysis via partial least squares discriminant analysis (PLS-DA) classification. Second, the NIR spectra in the remaining pixels corresponding to the wet granules were subjected to analysis of either theophylline content (in residence time studies) or moisture level (in granulation liquid distribution studies). The spectral range was narrowed to 1100-2200 nm and the spectra were subjected to the standard normal variate (SNV) in all analyses. The use of SNV preprocessing eliminates the additive baseline offset variations and multiplicative scaling effects in the spectra which may be caused by shadowed regions near large granules and possible differences in granule density.

#### *Segmentation: removal of background pixels from the analysis*

Since the wet granules and the plastic conveyor belt have distinct NIR spectra and since the collected spectral images consisted of regions dominated by one of these two materials, the segmentation task of extracting the pixels corresponding to the wet granules reduced to a relatively simple binary classification problem. The training set was constructed via manually collecting a large number of spectra (10 000 spectra per class) from a representative set of spectral images and assigning the reference value of 0 and 1 to the spectra corresponding to plastic conveyor belt and wet granules, respectively. The background spectra were collected

from two spectral images of clean plastic conveyor belt measured on two different days, and the target spectra were taken from three spectral images of wet granules (belonging to the data set measured in this study) which exhibited differences in both moisture and theophylline levels.

A linear model was constructed between the predictors and responses

$$y = \beta_0 + X\beta + \varepsilon \quad (1)$$

where the columns of matrix  $X$  are the spectra of the training set and the elements of the column vector  $y$  are the corresponding binary reference values. The intercept  $\beta_0$  and the regression vector  $\beta$  were estimated using PLS regression (with mean-centering on both  $X$  and  $y$ ), and the vector  $\varepsilon$  contains model residuals. A spatial pixel in a new spectral image corresponding to the spectrum  $x_{\text{new}}$  (a column vector) was then classified as background if  $\beta_0 + x_{\text{new}}^T \beta < \theta$  and as target otherwise. The model parameters – the number of latent variables in PLS regression and the threshold parameter  $\theta$  – were determined via visual inspection of the classification performance on the data collected in this study. The distributions of the non-thresholded output values of the PLS model formed two modes: the background pixels close to zero and the target pixels close to one. The separation between these two distribution peaks increased and their respective widths decreased as the PLS model dimensionality was increased. The number of latent variables was fixed to four since the distribution of PLS model output values remained rather constant higher model complexities. Instead of using the midpoint 0.5, the threshold parameter was fixed to 0.7 due to the fact that the plastic conveyor belt surface seen in the process measurements always contained a thin layer of dust (mainly Lactose and traces of theophylline) which made NIR spectrum of the surface look slightly more like the target material (wet granules) and thus shifted the distribution of the corresponding PLS predictions as well as the midpoint between the two distribution peaks towards right. Due to the large flat region between the two peaks in the distribution of the PLS model predictions, the classification model was not very sensitive to the exact value of the threshold parameter.



*Residence time analysis: estimation of theophylline level*

In the residence time analysis studies, a measure for the theophylline level was obtained with the spectral matched filter (SMF) which provides highly selective response for the target analyte and optimal suppression of interfering spectral effects.[23, 24]

The regression vector in SMF is calculated as

$$b = \frac{\Sigma^{-1}g}{g^T \Sigma^{-1}g} \quad (2)$$

where the column vector  $g$  is the pure analyte spectrum of theophylline which was measured from pure powder. The noise covariance matrix was calculated in this study as

$$\Sigma = \frac{N^T N}{N - 1} + \lambda I \quad (3)$$

where the  $N$  rows on the matrix  $N$  contain spectra from noise measurements which ideally contain all spectral variations which are not caused by changes in the concentration of the target analyte. The noise spectra ( $N = 10\ 000$ ) were manually picked from the spatial pixels corresponding to wet granules in the spectral images of process runs in which the theophylline was absent but the moisture level was varied. The noise space spanned by the rows of  $N$  thus contains spectral effects caused mainly by variations in moisture level and uneven illumination (shadows between granules). Identity matrix is denoted by  $I$  and the regularization parameter  $\lambda$  improves the invertibility of  $\Sigma$  and adjusts the degree to which the analyzed spectra are orthogonalized against the row space of  $N$ . The moisture predictions were not very sensitive to the values of the regularization parameter, and due to the qualitative nature of the study, it was not optimized in any way and it was set to  $\lambda = 10^{-9}$ . It must be noted that bias and slope correction was not conducted on the predictions obtained with the SMF model, and the estimated theophylline values – obtained via the inner product between the measured spectrum and the regression vector of Eq. 2 - may only be considered to be proportional to the true underlying values. The measurement is thus semi-quantitative.

*Estimation of moisture level from NIR spectra*

A feature which correlates selectively with the moisture level of the measured granules may be obtained using the ratio model

$$m = \frac{w - b}{c - b} \quad (4)$$

where the scalar values  $w$ ,  $c$  and  $b$  are mean pseudoabsorbance ( $\log_{10}(1/R)$ ) values in the spectral ranges 1890-2010, 2080-2160 and 1650-1750 nm, respectively. The numerator of Eq. (4) is thus the baseline-corrected area of the strong NIR absorption band of water centered at 1945 nm, and the denominator is similarly calculated area for the strong NIR band in the lactose spectrum centered at 2120 nm (Fig. 2). The baseline-correction point  $c$  is located in a spectral region where neither water nor lactose exhibits notable absorption. The additive variations in spectral baseline offset, and variations in optical path length (observed as multiplicative errors in spectra) are eliminated via baseline subtraction and division, respectively. It must be noted that the calculation of the semi-quantitative feature  $m$  thus contains a built-in scatter correction and is therefore insensitive to the use of SNV preprocessing.

Since the sample material is effectively a simple two-component system (lactose and water) in the studies of granulation liquid distribution, the use of a simple ratio model based on three spectral points is justified: there is no fear that interfering components would distort the spectral baseline level at 1650-1750 nm, for example. A univariate linear calibration model was constructed via regressing the nominal, approximately equidistant moisture levels between 4.1 and 9.0 % w/w of nine runs against the semi-quantitative feature  $m$  averaged over the target pixels in the corresponding spectral images (RMSEC=0.168 % w/w,  $R^2=0.988$ ). The calibration runs were conducted with the screw configuration of two zones of six kneading elements, and with the nozzle size of 1.6 mm and tube diameter of 3.2 mm. The obtained moisture maps were analyzed visually and via their distributions. The moisture levels of the target pixels were visualized as histograms and the statistical features of the distributions, mainly mean and standard deviation, were inspected.

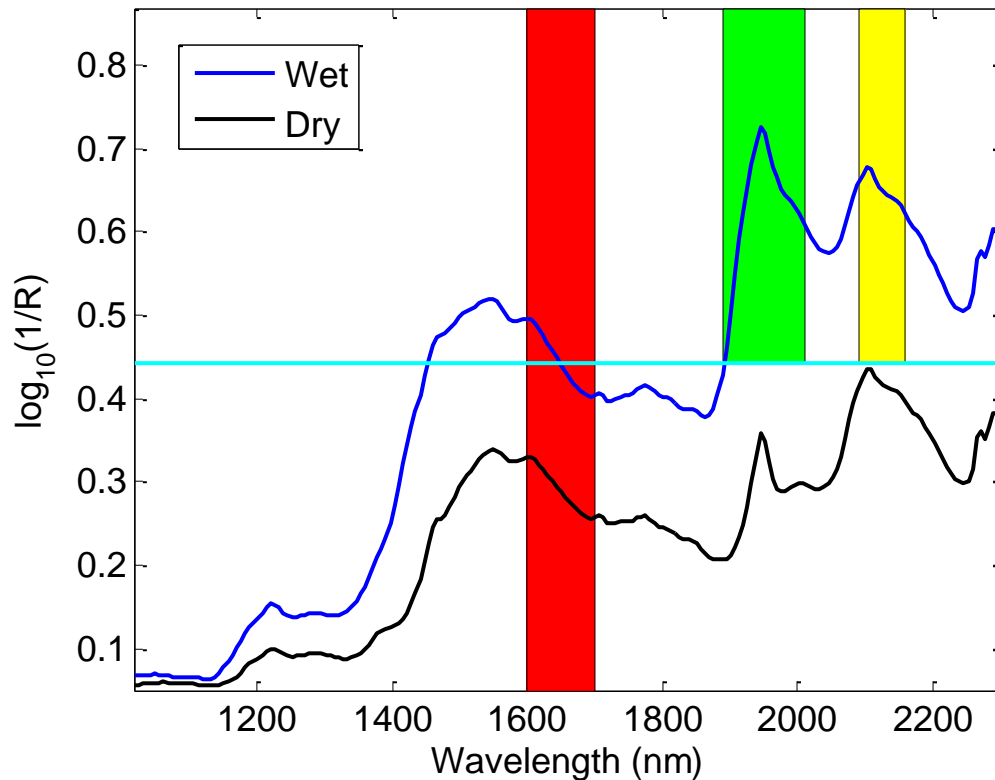

Figure 2: The calculation of the moisture-selective ratio model in Eq. 4. The numerator/denominator of the ratio model is calculated as the green/yellow area between the blue spectrum and the cyan baseline. The baseline level is calculated separately for each spectrum. Spectra from dry and wet regions of a spectral image of wet lactose granules are given in the figure.

### Experimental conditions

#### *Residence time analysis*

A two-level full factorial experimental design was performed to evaluate the influence of screw speed (600 – 900 rpm) and moisture content (2.3 – 6.7 % (w/w), based on wet mass) on the mean residence time and the residence time distribution. For each run, pure  $\alpha$ -lactose monohydrate was fed at 25 kg/h to the granulator. The screw configuration was composed of 2 kneading zones each consisting of 6 kneading elements ( $L=D/4$  for each kneading element) at an angle of 60 degrees. Both kneading zones were separated by a conveying element ( $L=1.5D$ ). An extra conveying element ( $L=1.5D$ ) was implemented after the second kneading block together with 2 narrow kneading elements ( $L=D/6$  for each

kneading element) in order to reduce the amount of oversized agglomerates, as reported by Van Melkebeke et al.[20] Liquid was added in front of the first kneading element. The barrel temperature was set constant at 25°C.

During processing, a 7.5 g shot of theophylline anhydrate was manually inserted into the powder inlet port of the granulator. The temporal profile of theophylline was monitored using the NIR chemical imaging system at the output of the granulator. The chemical imaging measurement was started 5 s after the insertion of the theophylline shot. Since it took 5 s for the granules to be transported from the granulator output to the location of the spectral image, the first frame of the spectral image corresponded to the time instant of theophylline addition. The spatial distribution of theophylline in the sample during the 20-s measurement was calculated with spectral matched filter as explained in the section Materials and methods. The intensity of the obtained chemical map was thus proportional to the theophylline level, and the residence time distribution could be determined via inspecting the temporally scanned direction of the spectral image.

*Monitoring and evaluation of granulation liquid homogeneity as function of liquid feed rate, liquid addition method and screw configuration*

The distribution of the granulation liquid through the powder bed was evaluated at various liquid feed rates, liquid addition methods and screw configurations. Pump orientation (in-phase and out-of-phase), tubing configuration (independent and split), number of liquid addition zones (1 and 2 zones), nozzle diameter (0.8, 1.6 and 2.4 mm) and pump type (peristaltic and piston pump) were varied. The screw configuration was altered between no kneading elements, 1 and 2 kneading zones of each 6 kneading elements ( $L=D/4$  for each kneading element) at an angle of 60 degrees. If 2 kneading zones were used, the screw configuration was composed as described above, whereas if 1 kneading zone was used, the second kneading zone (closer to the end of the screw) was substituted by a transport element ( $L=1.5D$ ). For all experiments, the powder feed rate was kept constant to 20 kg/h. All experimental conditions are summarized in Table 1.

For each experiment, the powder and liquid feed rate and liquid pump speed were logged by the ConsiGma<sup>TM</sup>-25 system. Moreover, statistical features such as the mean and standard deviation (STD) of the predicted moisture content of granules were extracted from the

moisture maps obtained by NIR chemical imaging using the calibrated ratio model, as explained in the section Materials and methods. The mean and STD of the predicted moisture content were plotted against the liquid feed rate in order to understand the influence of the different process variables upon the moisture uniformity. The STD of the moisture map was assumed to correlate inversely proportional to the moisture uniformity.

Furthermore, for each experiment, wet granules were collected and oven dried (40°C, 24h). After drying, particle size distribution (PSD) was determined via sieve analysis using a Retsch VE 1000 sieve shaker (Haan, Germany). Granules were placed on the shaker during 5 min at an amplitude of 2 mm using a series of sieves (150, 250, 500, 710, 1000, 1400 and 2000  $\mu\text{m}$ ). The amount of granules retained on each sieve was determined. The fraction < 150  $\mu\text{m}$ , between 150  $\mu\text{m}$  and 1400  $\mu\text{m}$  and > 1400  $\mu\text{m}$  were defined as fines, yield and agglomerates, respectively.

Table 1: Granulation liquid homogeneity evaluation as function of liquid feed rate, liquid addition method and screw configuration: experimental conditions and results for moisture uniformity (expressed as STD on the moisture map) and PSD.

Experiment	Liquid feed rate (g/min)	Pump orientation	Pump type	Tubing configuration	Screw configuration (number of kneading zones)	Liquid addition zones	Nozzle diameter
Liquid feed rate	14-30	in-phase	peristaltic	independent	2	1	1.6
Pump orientation	10-30	in-phase	peristaltic	independent	2	1	1.6
	10-30	out-of-phase	peristaltic	independent	2	1	1.6
	10-30	in-phase	peristaltic	split	1	1	1.6
	10-30	out-of-phase	peristaltic	Split	1	1	1.6
	6-30	N/A	piston	N/A	1	1	1.6
Tubing configuration	10-30	in-phase	peristaltic	independent	1	1	1.6
	10-30	in-phase	peristaltic	Split	1	1	1.6
Nozzle diameter	10-30	in-phase	peristaltic	independent	1	1	0.8
	10-30	in-phase	peristaltic	independent	1	1	1.6
	10-30	in-phase	peristaltic	independent	1	1	2.4
	10-30	in-phase	peristaltic	independent	0	1	1.6
Screw configuration	10-30	in-phase	peristaltic	independent	1	1	1.6
	10-30	in-phase	peristaltic	independent	2	1	1.6
	10-30	in-phase	peristaltic	independent	2	1	1.6
Liquid addition zones	10-30	out-of-phase	peristaltic	split	2 x 1	2	1.6

*Monitoring and evaluation of granulation liquid homogeneity as function of moisture content and barrel filling degree*

After optimizing the liquid addition method and the screw configuration to improve the distribution of granulation liquid through the powder bed, a two-level full factorial design was performed to evaluate the influence of three variables on the moisture uniformity and PSD of the granules: powder feed rate (15 - 25 kg/h), screw speed (600 - 950 rpm) and moisture content (3.8 – 9.0 % (w/w), based on wet mass). Both the powder feed rate and screw speed determine the barrel filling degree. Three replicates of the design center point were run. The different factor settings for each experiment are listed in Table 2. For all runs, the screw configuration was composed as described in the section Materials and methods. Liquid was added in front of the first kneading element. The barrel temperature was kept constant to 25°C. For each experiment, NIR chemical images were collected and 400 g of freshly produced granules were sampled and oven dried (40°C, 24h) for off-line PSD analysis. STD and full width at half maximum (FWHM) were extracted from the moisture maps obtained by chemical imaging. The results were evaluated with MODDE 9.0 software (Umetrics, Umeå, Sweden).

Table 2: Overview of runs from the experimental design: factor variables (powder feed rate, screw speed and moisture level) and responses (STD and FWHM on the moisture map, fines, yield and agglomerates).

Run	Powder feed rate (kg/h)	Screw speed (rpm)	Moisture level (°C)	STD on the moisture map (%)	FWHM on the moisture map (%)	Fines (%)	Yield (%)	Agglomerates (%)
1	25	600	3.8	0.7609	1.3396	56.3	42.0	6.1
2	20	775	6.4	0.3242	0.6677	19.5	48.6	32.5
3	25	600	9.0	0.3130	0.6612	2.8	42.0	56.2
4	15	600	9.0	0.3090	0.6688	4.3	44.7	51.0
5	15	950	9.0	0.3177	0.6699	4.8	50.7	43.9
6	20	775	6.4	0.3210	0.6633	17.8	46.6	35.7
7	15	950	3.8	0.6600	1.0372	53.2	45.3	2.8
8	15	600	3.8	0.8126	1.2935	54.2	42.9	3.2
9	25	950	9.0	0.3569	0.7015	5.2	49.7	40.0
10	20	775	6.4	0.3239	0.6681	18.2	52.4	31.1
11	25	950	3.8	0.7666	1.2658	53.7	38.1	2.9



## RESULTS AND DISCUSSION

### Residence time analysis

Residence time analysis of a tracer molecule (theophylline) as a function of moisture content and screw speed was performed. Fig. 3 represents the API chemical map and mean temporal profile of the experiments performed at 6.7 % moisture content (w/w, based on wet mass) and a screw speed equal to 600 and 950 rpm, respectively. At the lowest screw speed tracer molecules were detected between 3 and 17 seconds after insertion, while for the highest screw speed the residence time of particles varied between 2 and 8 s after insertion. This indicated that the flow behavior of the materials was more plug flow at high screw speed as narrower residence time distributions were obtained. Obviously, it could be concluded that the screw speed inversely correlated with the mean residence time (4s and 10s for highest and lowest screw speed, respectively). Decreasing the moisture content from 6.7 to 2.3 % tended to slightly decrease the mean residence time and the width of the residence time distribution (data not shown).

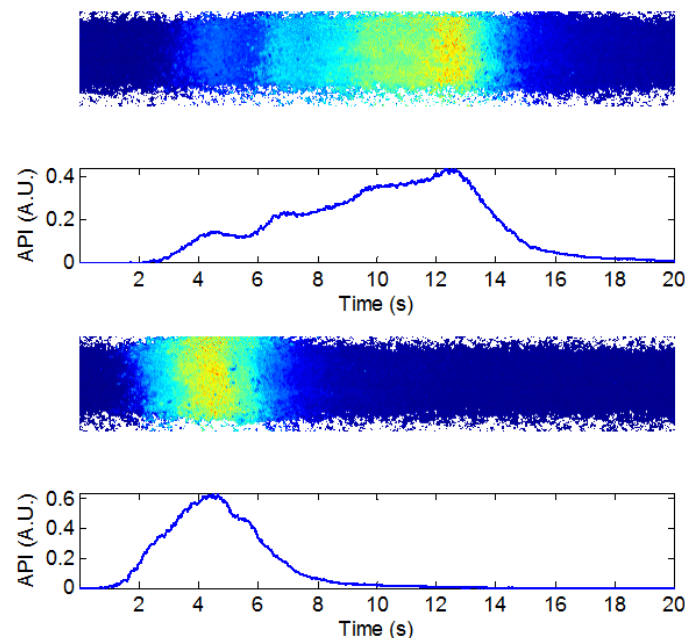

Figure 3: API chemical map and mean temporal profile of experiments performed at high moisture content (6.7 % (w/w), based on wet mass) and a screw speed equal to 600 rpm (top) and 900 rpm (bottom).

It is expected that the solid state of theophylline changes from anhydrate to monohydrate during continuous wet granulation. Since the changes caused by the solid state conversion on the characteristic NIR spectrum of theophylline are seen as variations in the intensities of very narrow (less than 10 nm in width) and overlapping absorption bands [2], reliable detection of the solid state of theophylline would require the use of a Fourier transform NIR spectrometer with high spectral resolution. However, the current dispersive NIR spectrometer with spectral resolution of 10 nm, as specified by the manufacturer, did not provide enough sensitivity for detection of these changes. Despite the spectral changes caused by solid state conversion, the general shape of the theophylline spectrum in the analysed spectral range remained relatively constant. It is thus expected that the semi-quantitative theophylline abundance maps calculated with the spectral matched filter are relatively insensitive to the solid state of theophylline. Naturally, a quantitative calibration would have to be constructed in order to take into account the variations in the solid state.

#### **Influence of liquid feed rate, liquid addition method and screw configuration on granulation liquid homogeneity**

Whereas the residence time of material inside batch granulators (i.e. fluid bed and high-shear granulators) is in the order of minutes, the residence time inside a twin screw granulator is limited to seconds. As a consequence, the time for granulation liquid to be homogeneously spread through the powder is very short. As already described by El Hagrasy et al.[10], the distribution of granulation liquid into the powder bed inside a twin screw granulator and the link between the uneven liquid distribution and the bimodal PSD of granules produced by twin screw granulation is not yet fully understood. Therefore, it was attempted in this study to use NIR chemical imaging in order to get better insight into the influence of different formulation and process variables (liquid feed rate, liquid addition method and screw configuration) on the moisture homogeneity of the wet granules. Furthermore, results from NIR chemical imaging were compared with particle size results of granules in order to improve process understanding of continuous twin screw granulation technology.

During preliminary granulation experiments, the liquid feed rate was varied from 10 to 30 g/min at constant powder feed rate (20 kg/h). Fig. 4 gives an overview of chemical imaging

results represented as a moisture map, mean temporal moisture profile and histogram from the moisture map obtained at low liquid feed rate (16 g/min). From the moisture map as well as from the temporal moisture profile, clear periodic temporal fluctuations in moisture level could be detected. The period of the fluctuations decreased (i.e. frequency increased) as the liquid feed rate increased (Fig. 5). Furthermore, the STD on the moisture map decreased if the liquid feed rate was increased.

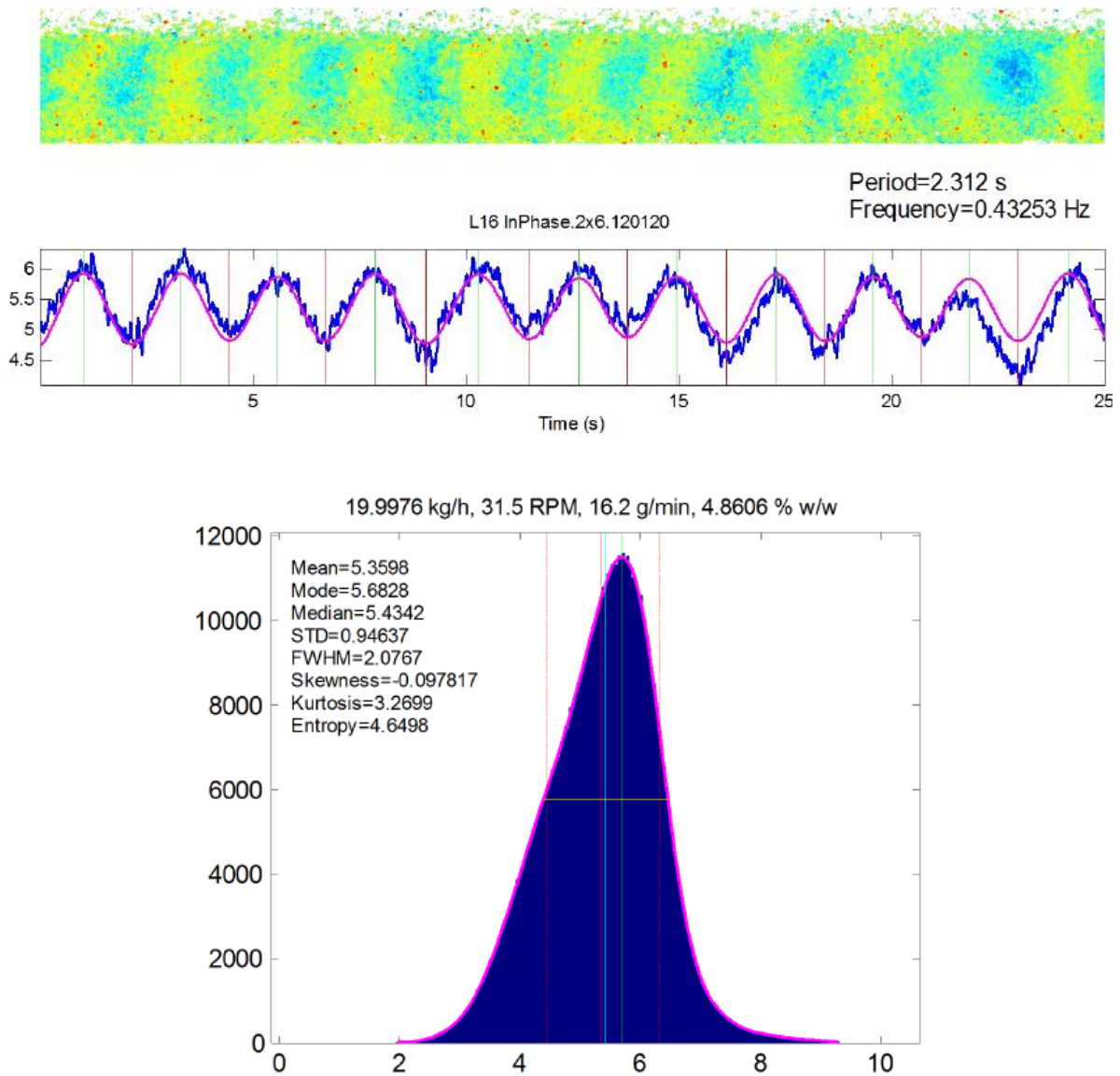

Figure 4: Moisture map (top), mean temporal moisture profile (middle) and histogram (bottom) of moisture content at low liquid feed rate (16 g/min).

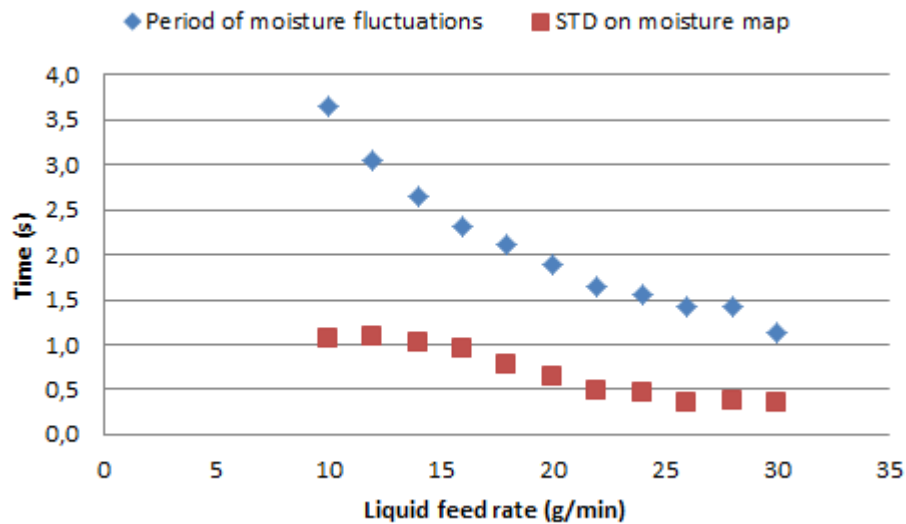

Figure 5: NIR chemical imaging results in function of liquid feed rate: period of moisture fluctuations and STD on the moisture map.

By examination of the peristaltic pumps at operation, it was observed that the oscillations seen in the chemical images were of the same frequency as the fluctuations from the liquid pulses given by the pumps. This phenomenon was enlarged because of the use of liquid tubings with a wide inner diameter, namely 3.2 mm. As each peristaltic pump consisted of a head with three rollers, the simultaneous operating pumps produced each three pulses per revolution. The causal relation between the fluctuations of the peristaltic pump and the temporal oscillations observed in the moisture level of the granules was verified via inspecting their relations with the liquid pump speed (RPM) logged by the ConsiGma<sup>TM</sup>-25 system. A strong linear relation between the liquid pump speed and the frequency of oscillations was found and the coefficients of the linear fits were equal when the oscillation frequencies were calculated both from the NIR chemical imaging data and from counting the number of liquid pulses within a constant time period in a separate offline measurement.

As it was suggested that the STD of the moisture map was also correlated to the pulsation of the peristaltic pumps, granulation experiments were performed using two peristaltic pumps at maximal phase difference (out-of-phase). By placing the pumps out-of-phase, the periodic temporal moisture fluctuations vanished (Fig. 6). However, as can be seen from Fig. 7a, moisture uniformity was only slightly better if the pumps were out-of-phase, in comparison to in-phase orientation of the pumps. Furthermore, changing the orientation of the

peristaltic pumps from in-phase to maximally out-of-phase did not affect the PSD of the granules (Fig. 8a).

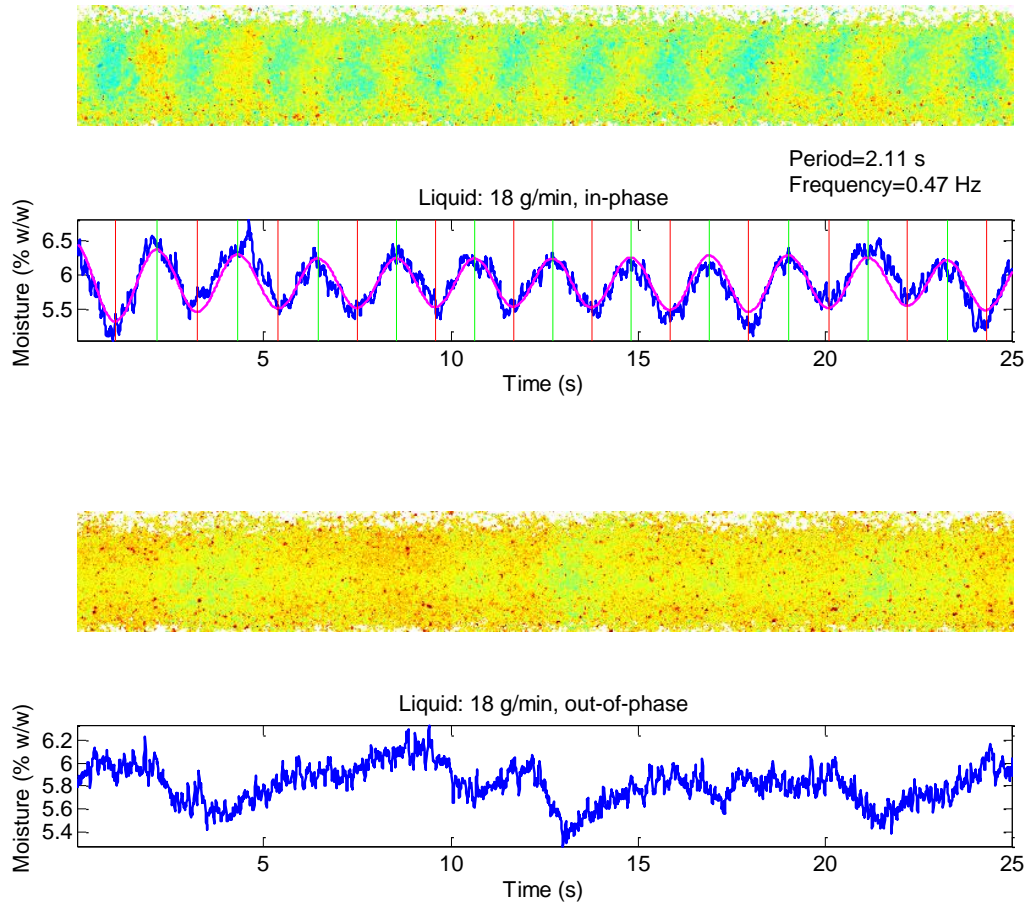

Figure 6: Moisture map and mean temporal moisture profile of experiments with different pump orientation: in-phase (top) and out-of-phase (bottom).

The impact of changing the tubing configuration on the moisture uniformity of the granules was studied. The experimental set-up where two independent tubings each go through a separate peristaltic pump was compared with liquid addition via a single tubing that was split into two tubings at the level of the peristaltic pumps and then again combined into a single tubing (Fig. 9). In the latter case, fluid flow was split into two fluid flows with in-phase or out-of-phase paths, depending on the orientation of the pumps. Just before entering the liquid port of the barrel, the single tubing was again split in order to add the granulation liquid via two nozzles on top of both screws. In this way, in comparison to independent tubings a higher liquid pump speed was needed to reach the same liquid feed rate, in case of

the split tubing configuration, resulting in a lower pulsation of the liquid addition. From Fig. 7b, it is clear that only slightly better moisture uniformity was obtained if split tubing was used compared to independent tubings. Changing the orientation of the peristaltic pumps (in-phase vs. out-of-phase) when using split tubing did not have an impact on the moisture homogeneity (data not shown). This could be explained by the moisture fluctuations with a lower period for split tubing configuration. Furthermore, changing the tubing configuration did not affect the PSD of the granules (data not shown).

As it was suggested that multiple injections of granulation liquid across the length of the barrel would improve the moisture uniformity [18], the use of two liquid addition zones was investigated. Hereby, the liquid was inserted into the barrel using four nozzles (two nozzles per liquid addition zone). A kneading zone of 6 kneading elements at 60 degrees was located immediately after each liquid addition zone. In contrast to Shah et al.[18], who claimed that a better moisture distribution could be obtained by using multiple liquid additions, the use of two liquid addition zones was not beneficial for the moisture uniformity, according to the chemical imaging results. The moisture uniformity and the PSD (data not shown) of the granules were comparable to a setup with 1 liquid addition zone followed by 2 kneading zones of each 6 kneading elements at 60 degrees (Fig 7c).

For twin screw granulation processes, granulation liquid is typically added by dripping the liquid via peristaltic pumps into the powder which impedes the distribution of the liquid phase into the powder phase, as this results in large droplets compared to a spraying mode. Kayrak-Talay and Litster recently compared the PSD of granules produced in a batch high-shear mixer with addition of granulation liquid in the dripping and spraying mode. They concluded that the addition of the liquid in the dripping mode gave the broadest size distribution with ungranulated fines and a high percentage of lumps compared to the spraying mode. As the diameter of the nozzle used to add the granulation liquid into the barrel directly influences the droplet size, experiments were performed with nozzles having different diameters (0.8, 1.6 and 2.4 mm). However, changing the nozzle diameter did not affect the moisture uniformity (Fig. 7d) nor the PSD of the granules (data not shown).

a

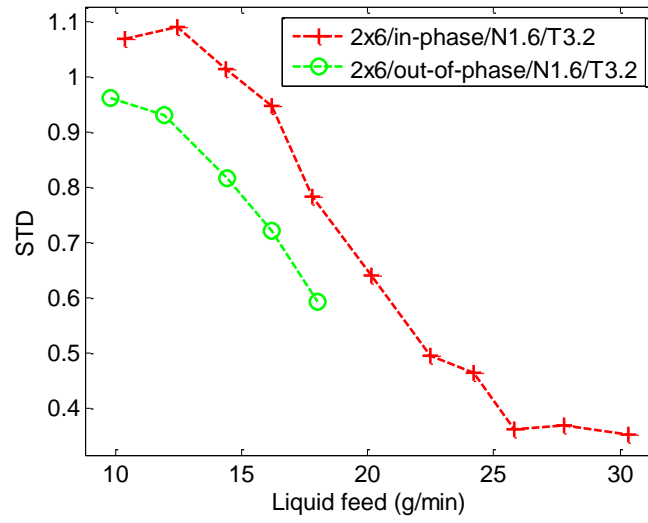

b

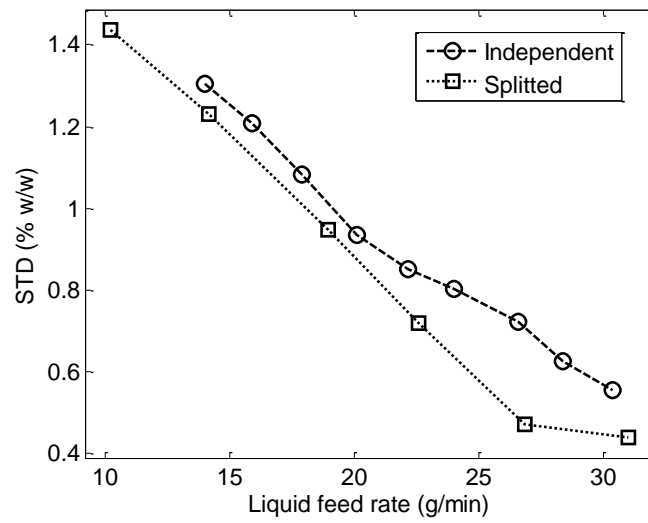

c

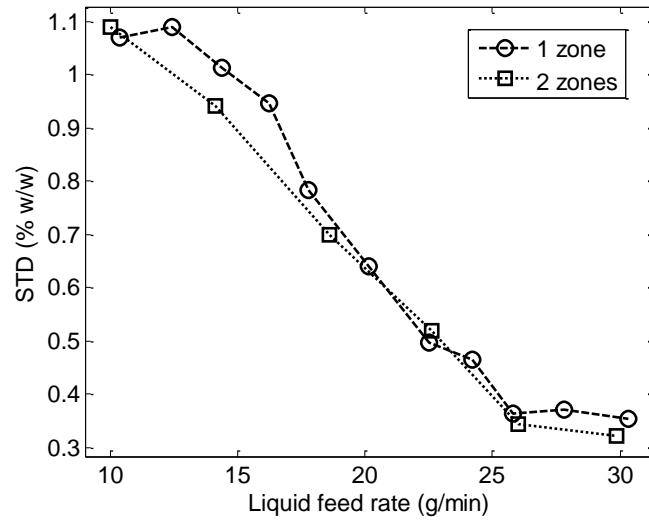

d

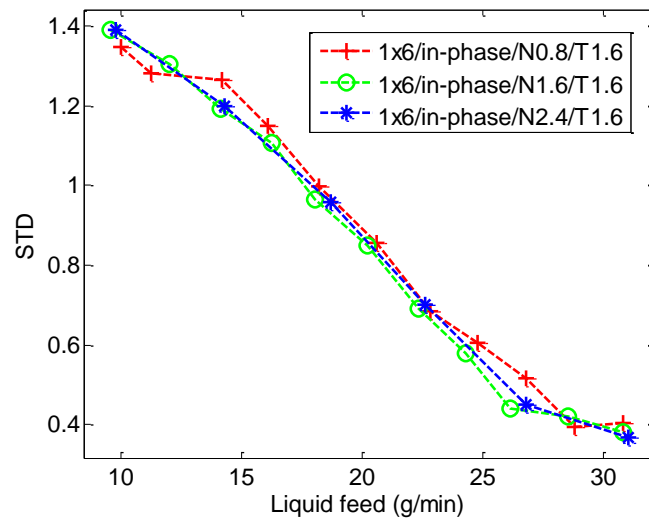



e

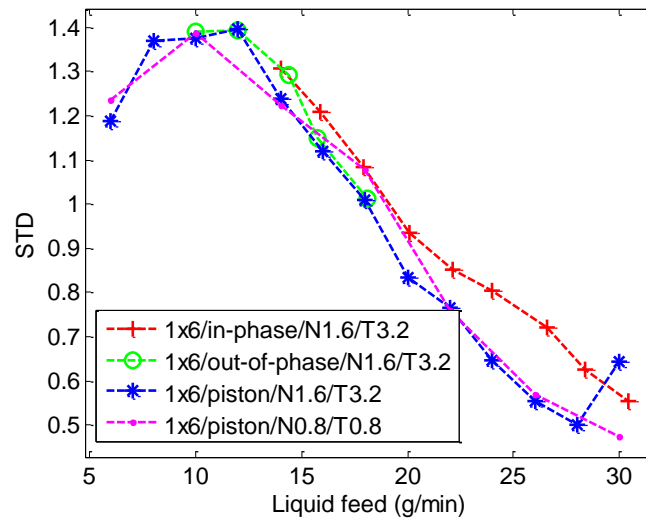

f

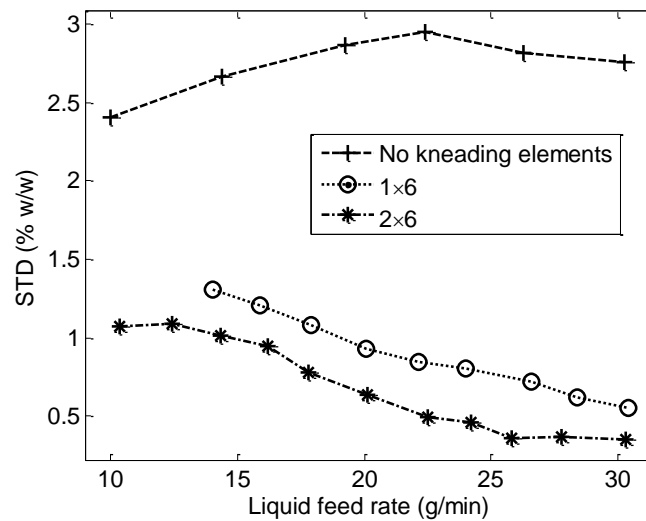

Figure 7: STD on the moisture map in function of liquid feed rate for (a) different pump orientations (in-phase and out-of-phase), (b) tubing configurations (independent and split), (c) liquid addition zones (1 and 2), (d) nozzle diameter (0.8, 1.6 and 3.2), (e) pump type (peristaltic and piston pump) and (f) screw configuration (no kneading elements, 1 zone and 2 zones of 6 kneading elements) (N: nozzle diameter, T: tubing inner diameter).

In order to avoid the natural pulsation of the peristaltic pumps, granulation experiments were performed using a piston pump. However, by comparing the results from the chemical images, the piston pump did not have any advantage compared to peristaltic pumps

regarding moisture uniformity. Although the fluctuations from the mean temporal profile vanished using a piston pump, the STD on the moisture homogeneity of the wet granules was similar (Fig. 7e). Furthermore, using different nozzle diameters or tubing diameters in combination with the piston pump did not affect the PSD of the granules (Fig. 8b).

Fig. 7f shows the STD on the moisture maps in function of the liquid feed rate for runs performed using different screw configurations (no kneading elements, 1 kneading zone and 2 kneading zones of each 6 kneading elements at 60 degrees). Again, it is evident that the moisture uniformity improved if the moisture content of the granules increased. Furthermore, when no kneading elements were used high STD on the moisture maps were obtained, indicating poor distribution of granulation liquid into the powder bed. At the same liquid feed rate, the use of 2 kneading zones resulted in a lower STD on the moisture map compared to 1 kneading zone. This could be expected as kneading elements are used in twin screw granulation to intensively mix the powder and liquid phase. Fig. 8c shows PSD results for granules produced with different screw configurations (no kneading zones, 1 and 2 kneading zones). In agreement with the NIR chemical imaging results, processing without kneading elements resulted in a wide particle size distribution with a high amount of fine particles, indicating limited mixing between powder and liquid phase. Increasing the number of kneading zones resulted in a lower amount of fines and a higher amount of agglomerates, due to more intensive mixing of both liquid and powder phase. Increasing the liquid feed rate resulted in a lower amount of fines and a higher amount of agglomerates (data not shown). Although the STD on the moisture map could be drastically reduced by increasing the number of kneading elements, the PSD data of the granules still showed a wide and bimodal profile. This indicated that the typical wide and bimodal PSD for granules produced by twin screw granulation is not mainly caused by the insufficient mixing of powder and liquid phase during the short residence time of material inside the barrel, but rather to the granulation mechanism inherent to the technique.

a

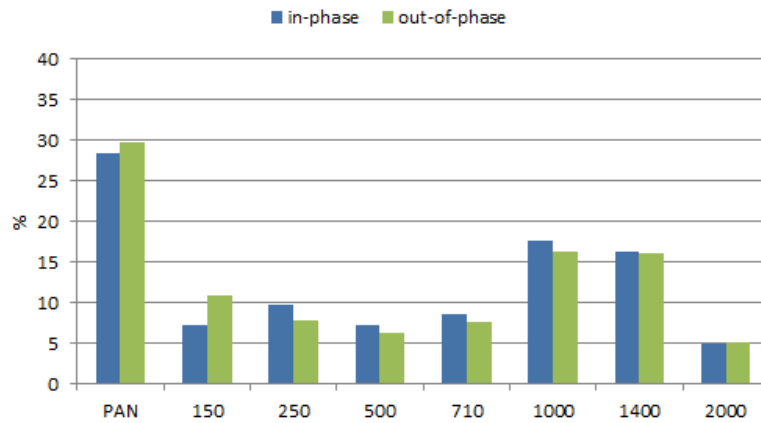

b

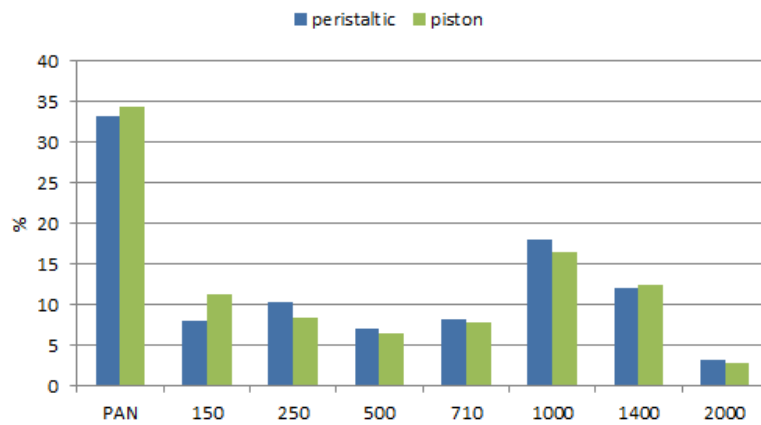

c

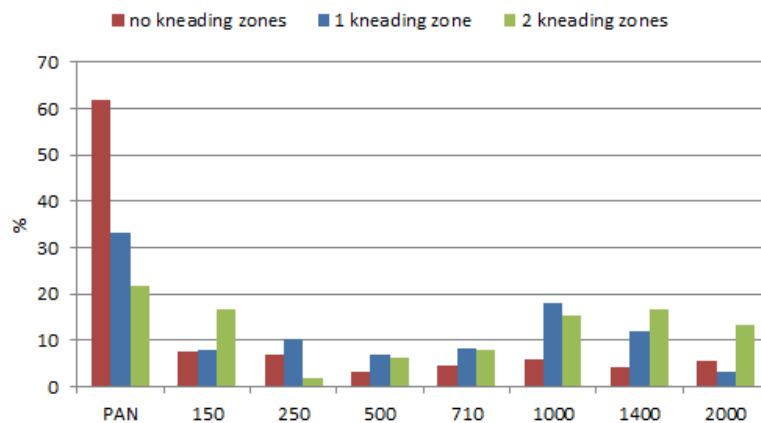

Figure 8: Particle size distribution of granules produced with (a) different pump orientation (in-phase and out-of-phase), (b) pump type (peristaltic and piston pump) and (c) screw configuration (no kneading elements, 1 zone and 2 zones of 6 kneading elements).

In case of granulation with independent tubings and the two peristaltic pumps operating in-phase, distinct zones could be distinguished with the chemical imaging system with differences in moisture content. In order to link the fluctuations on the moisture map with the PSD of the granules, granules of a run performed at low liquid feed rate (14g/min) were sampled from both the dry and wet zones on the conveyor belt of the chemical imaging system. However, PSD results were similar for both zones (data not shown). This indicated that the moisture content range wherein fluctuations were observed in the chemical imaging data was too narrow to cause significant PSD changes between the lower and the upper level of moisture content. Furthermore, this explains why PSD of granules was not affected if moisture fluctuations vanished by modifying the liquid addition method (e.g. pump orientation, pump type).

The above described experiments showed that the liquid distribution inside the granulator, represented by the STD on the moisture map, could only be improved by increasing the number of kneading zones or the moisture content of the granules. By changing the liquid addition method (i.e. pump orientation, tubing configuration, number of liquid addition zones, nozzle diameter and pump type), moisture fluctuations could be minimized. However, moisture uniformity and PSD of granules were only slightly be affected.

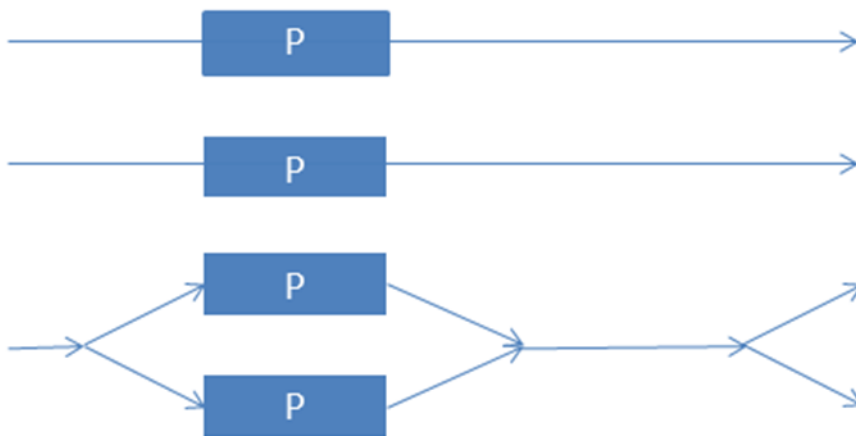

Figure 9: Tubing configuration: independent tubings (top) and split tubing configuration (bottom) (P: peristaltic pump).

### **Influence of moisture content and barrel filling degree on granulation liquid homogeneity**

Based on the results obtained in the previous section, the liquid addition method (i.e. out-of-phase orientation and split tubing configuration) and screw configuration (i.e. 2 kneading zones) were optimized in order to minimize the STD on the moisture maps. Subsequently, the influence of the moisture content and filling degree of the barrel on the moisture uniformity and PSD of granules was investigated. Therefore, a three-factor two-level full factorial design was performed: powder feed rate (15 - 25 kg/h), screw speed (600 - 950 rpm) and moisture content (3.8 – 9.0 % (w/w), based on wet mass). Both the powder feed rate and screw speed determine the barrel filling degree. Hereby, high powder feed rate and low screw speed result in a high barrel filling degree and vice versa.

The three investigated parameters (moisture content, powder feed rate and screw speed) and their interactions were regressed against the STD and full width at half maximum (FWHM) of the moisture maps. It was suggested that a lower filling degree would yield a less dense powder bed promoting the distribution of granulation liquid. However, it seemed that changing the filling degree of the granulator did not have a significant effect on the efficiency of the mixing between powder and liquid. Increased free volume inside the barrel at low filling degree could not improve the water distribution inside the powder phase. It turned out that only the moisture content of the wet granules was a significant factor for the moisture uniformity: the higher the moisture content of the granules, the lower the STD on the moisture map. If a lower amount of water was added to the powder phase, less homogeneous moisture maps were detected. Hence, it is more difficult to evenly distribute low liquid levels through the powder bed. This is in agreement with earlier described research work.[10, 22] The same conclusions were made based on the FWHM of the moisture distributions. The coefficients of determination in leave-one-out cross-validation ( $Q^2$ -values) for STD and FWHM were very poor (-1.91 and -1.87, respectively) when all linear and interaction terms were included in the model, and they were somewhat improved (to 0.64 and 0.59, respectively) when only the moisture level was used as a single explanatory variable. The relationship between the moisture level and STD of the moisture distribution is thus highly non-linear, which is seen in the predicted vs. reference correlation plot (data not shown). The three moisture levels in the experimental design form separate clusters, and the reference values for the STD (i.e. those calculated from the spectral images) are very

similar in the clusters corresponding to the high and medium moisture levels, whereas the dry cluster has significantly higher values of STD.

From the effect plots of the fines, yield and agglomerates, it is obvious that changing the filling degree of the barrel by varying the screw speed and the powder feed rate did not significantly influence the PSD of the granules. Only the moisture content had a significant effect on the PSD. Increased moisture content resulted in less fines (<150  $\mu\text{m}$ ) and a higher amount of oversized granules (>1400  $\mu\text{m}$ ). However, the yield was not affected by the moisture content. This is in agreement with earlier published research [21]. These data indicated that although the STD and the FWHM of the moisture were reduced at increased moisture content, the PSD could not be significantly narrowed as the yield remained constant. Hence, a better homogeneity of the granulation liquid distribution through the powder bed was not reflected in the width of the PSD of the granules, indicating that the granulation mechanism as such is at the basis of the typical wide PSD for granules continuously produced by the twin screw granulation technique, rather than the distribution of granulation liquid through the powder bed during the short residence time in the barrel.

## **CONCLUSIONS**

NIR chemical imaging was shown to be an adequate analytical tool for residence time analysis as representative and fast measurements could be obtained. Increased screw speed and decreased moisture content led to a lower mean residence time and narrower residence time distribution. Besides, the moisture homogeneity of granules produced by continuous twin screw granulation was visualized. The influence of several variables (liquid addition method, screw configuration, moisture content and barrel filling degree) on the moisture homogeneity was evaluated. STD on the moisture maps could only be drastically reduced if the number of kneading zones of the screws and the moisture content was increased. Changing the liquid addition method (pump orientation (in-phase vs. out-of-phase), pump type (peristaltic vs. piston pump), tubing configuration (independent vs. split tubing), nozzle diameters (0.8, 1.6 and 2.4 mm) and liquid addition zones (1 vs. 2 zones)) or the barrel filling degree did not have an impact on the mixing efficiency of powder and liquid phase. Although moisture uniformity could be achieved with more kneading zones and at a higher liquid feed rate, PSD results showed wide and bimodal profiles, indicating that the typical bimodal PSD

for granules produced by twin screw granulation is not mainly caused by the insufficient mixing of powder and liquid phase during the short residence time of material inside the barrel but rather to the granulation mechanism inherent to the technique.

This study demonstrated that NIR chemical imaging is a fast and adequate analytical technique to improve process understanding and a useful tool for optimization of a continuous twin screw granulation process. Although NIR chemical imaging is not readily applicable for in-line monitoring of a continuous granulation process, it can be considered as a convenient research tool during process development and optimization.

## REFERENCES

- [1] C. Vervaet, J.P. Remon, Continuous granulation in the pharmaceutical industry, *Chem Eng Sci*, 60 (2005) 3949-3957.
- [2] M. Fonteyne, J. Vercruysse, D.C. Díaz, D. Gildemyn, C. Vervaet, J.P. Remon, T.D. Beer, Real-time assessment of critical quality attributes of a continuous granulation process, *Pharm Dev Technol*, 18 (2013) 85-97.
- [3] L. Chablani, M.K. Taylor, A. Mehrotra, P. Rameas, W.C. Stagner, Inline Real-Time Near-Infrared Granule Moisture Measurements of a Continuous Granulation–Drying–Milling Process, *AAPS PharmSciTech*, 12 (2011) 1050-1055.
- [4] S.M. Iveson, J.D. Litster, Growth regime map for liquid-bound granules, *Aiche J*, 44 (1998) 1510-1518.
- [5] S.M. Iveson, J.D. Litster, K. Hapgood, B.J. Ennis, Nucleation, growth and breakage phenomena in agitated wet granulation processes: a review, *Powder Technol*, 117 (2001) 3-39.
- [6] L.X. Liu, J.D. Litster, S.M. Iveson, B.J. Ennis, Coalescence of deformable granules in wet granulation processes, *Aiche J*, 46 (2000) 529-539.
- [7] L.X. Liu, R. Smith, J.D. Litster, Wet granule breakage in a breakage only high-shear mixer: Effect of formulation properties on breakage behaviour, *Powder Technol*, 189 (2009) 158-164.
- [8] H.S. Tan, A.D. Salman, M. Hounslow, Kinetics of fluidised bed melt granulation III: Tracer studies, *Chem Eng Sci*, 60 (2005) 3835-3845.
- [9] H.S. Tan, A.D. Salman, M.J. Hounslow, Kinetics of fluidised bed melt granulation I: The effect of process variables, *Chem Eng Sci*, 61 (2006) 1585-1601.
- [10] A.S. El Hagrasy, J.R. Hennenkamp, M.D. Burke, J.J. Cartwright, J.D. Litster, Twin screw wet granulation: Influence of formulation parameters on granule properties and growth behavior, *Powder Technol*, 238 (2012) 108-115.



- [11] H.N. Emady, D. Kayrak-Talay, W.C. Schwerin, J.D. Litster, Granule formation mechanisms and morphology from single drop impact on powder beds, *Powder Technol*, 212 (2011) 69-79.
- [12] W.J. Wildeboer, E. Koppendraaier, J.D. Litster, T. Howes, G. Meesters, A novel nucleation apparatus for regime separated granulation, *Powder Technol*, 171 (2007) 96-105.
- [13] R.M. Dhenge, J.J. Cartwright, M.J. Hounslow, A.D. Salman, Twin screw granulation: Steps in granule growth, *Int J Pharm*, 438 (2012) 20-32.
- [14] D. Djuric, P. Kleinebudde, Impact of Screw Elements on Continuous Granulation With a Twin-Screw Extruder, *J Pharm Sci*, 97 (2008) 4934-4942.
- [15] D. Djuric, P. Kleinebudde, Continuous granulation with a twin-screw extruder: Impact of material throughput, *Pharm Dev Technol*, 15 (2010) 518-525.
- [16] D. Djuric, B. Van Melkebeke, P. Kleinebudde, J.P. Remon, C. Vervaet, Comparison of two twin-screw extruders for continuous granulation, *Eur J Pharm Biopharm*, 71 (2009) 155-160.
- [17] E.I. Keleb, A. Vermeire, C. Vervaet, J.P. Remon, Twin screw granulation as a simple and efficient tool for continuous wet granulation, *Int J Pharm*, 273 (2004) 183-194.
- [18] U. Shah, Use of a Modified Twin-Screw Extruder to Develop a High-Strength Tablet Dosage Form, *Pharm Technol*, 6 (2005) 52-66.
- [19] M.R. Thompson, J. Sun, Wet Granulation in a Twin-Screw Extruder: Implications of Screw Design, *J Pharm Sci*, 99 (2010) 2090-2103.
- [20] B. Van Melkebeke, C. Vervaet, J.P. Remon, Validation of a continuous granulation process using a twin-screw extruder, *Int J Pharm*, 356 (2008) 224-230.
- [21] J. Vercruyssen, D.C. Diaz, E. Peeters, M. Fonteyne, U. Delaet, I. Van Assche, T. De Beer, J.P. Remon, C. Vervaet, Continuous twin screw granulation: Influence of process variables on granule and tablet quality, *Eur J Pharm Biopharm*, 82 (2012) 205-211.
- [22] R.M. Dhenge, R.S. Fyles, J.J. Cartwright, D.G. Doughty, M.J. Hounslow, A.D. Salman, Twin screw wet granulation: Granule properties, *Chem Eng J*, 164 (2010) 322-329.

[23] R. Marbach, A new method for multivariate calibration, *J near Infrared Spec*, 13 (2005) 241-254.

[24] N.M. Nasrabadi, Regularized Spectral Matched Filter for Target Recognition in Hyperspectral Imagery, *Signal Processing Letters, IEEE*, 15 (2008) 317-320.

# 3

## **IMPACT OF SCREW CONFIGURATION ON THE PARTICLE SIZE DISTRIBUTION OF GRANULES PRODUCED BY TWIN SCREW GRANULATION**

Parts of this chapter are submitted to European Journal of Pharmaceutics and Biopharmaceutics:

J. Vercruyse, A. Burggraeve, M. Fonteyne, U. Delaet, I. Van Assche, P. Cappuyens, T. De Beer, J.P. Remon, C. Vervaet, Impact of screw configuration on the particle size distribution of granules produced by twin screw granulation.

**Abstract**

Twin screw granulation (TSG) has been reported by different research groups as an attractive technology for continuous wet granulation. However, in contrast to fluidized bed granulation, granules produced via this technique typically have a wide and multimodal particle size distribution (PSD), resulting in suboptimal flow properties. The aim of the current study was to evaluate the impact of granulator screw configuration on the PSD of granules produced by TSG.

Experiments were performed using a 25-mm co-rotating twin screw granulator, being part of the ConsiGma<sup>TM</sup>-25 system (a fully continuous from-powder-to-tablet manufacturing line from GEA Pharma Systems). Besides the screw elements conventionally used for TSG (conveying and kneading elements), alternative designs of screw elements (tooth-mixing-elements (TME), screw mixing elements (SME) and cutters) were investigated using an  $\alpha$ -lactose monohydrate formulation granulated with distilled water.

Granulation with only conveying elements resulted in wide and multimodal PSD. Using kneading elements, the width of the PSD could be partially narrowed and the liquid distribution was more homogeneous. However, still a significant fraction of oversized agglomerates was obtained. Implementing additional kneading elements or cutters in the final section of the screw configuration was not beneficial. Furthermore, granulation with only TME or SME had limited impact on the width of the PSD. Promising results were obtained by combining kneading elements with SME, as for these configurations the PSD was narrower and shifted to the size fractions suitable for tableting.

**KEYWORDS:** Continuous processing, Twin screw granulation, Screw configuration, Particle size distribution, Process understanding

## INTRODUCTION

Twin screw granulation (TSG) is an attractive technology for the continuous production of pharmaceuticals as it provides the optimum throughput for pharmaceutical manufacturing combined with the advantages of a continuous operating mode [1, 2]. During the last decade, several research groups described the importance of the granulator screw configuration on machinery performance and granule and tablet quality [2-8]. Due to the modular set-up of the granulator screws inside a TSG, endless combinations of different types of screw elements are possible. Whereas this renders enormous flexibility, only limited fundamental knowledge is available about the screw configuration. The screw elements which are commonly used for TSG (conveying and kneading elements, Fig.1a and b) were originally developed to convey and mix molten polymers during hot melt extrusion. However, it is important to evaluate if these elements remain useful for a wet granulation process.

Compared to Keleb et al. [4], Van Melkebeke et al. [7] reduced the length of the granulation zone in order to reduce possible degradation by mechanical stress or increase of temperature. By doing this, no negative effects on granule or tablet properties were detected. However, an extra conveying element after the kneading block was essential to improve the granulation yield based on a reduction of the oversized agglomerates. Djuric and Kleinebudde [9] concluded that the use of kneading elements resulted in an almost complete agglomeration of lactose, whereas conveying and combing mixer elements yielded smaller granules. Thompson and Sun [6] stated that energy-intensive mixing elements such as kneading and combing mixer elements induced substantial particle growth over a single element. Vercruyssen et al. [8] reported that the powder was more intensively mixed with the granulation liquid using kneading elements, yielding less fines and more oversized agglomerates.

In contrast to granules produced by fluid bed granulation (FBG) which typically results in monomodal and narrow PSD, a broad and multimodal PSD with a significant fraction of small as well as large granules has been reported after TSG [2-4, 7-15]. Dhenge et al. [10, 11, 16] concluded that a monomodal PSD was only observed at high liquid-to-solid ratio (L/S ratio). However, the distribution was wide and the  $d_{50}$  was around 1000  $\mu\text{m}$  which is not suitable

for tableting. Lee et al. [17] compared the PSD of granules produced by batch high shear granulation (HSG) and continuous TSG. Following HSG the PSD was narrow and monomodal, whilst TSG resulted in granules with a wider and bimodal size distribution. Also in this case, a monomodal PSD could only be obtained at high L/S ratio.

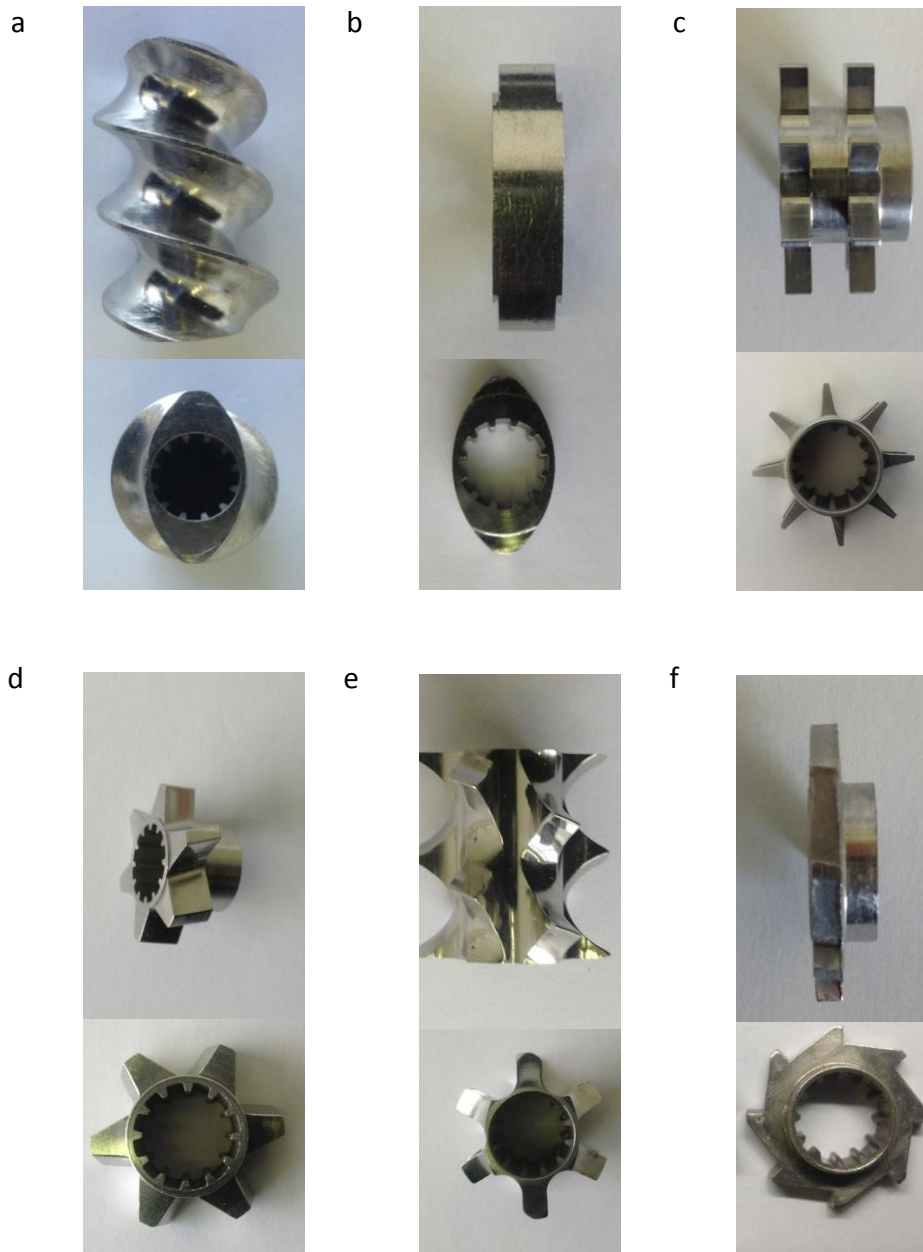

Figure 1: Representation of the screw elements used in this study: conveying element (a), kneading element (b), narrow tooth-mixing-element (c), wide tooth-mixing-element (d), screw mixing element (e), and cutter (f).

In the current study, a model formulation was granulated using batch FBG and continuous TSG. PSDs for granules produced by both techniques were evaluated and compared. Furthermore, the impact of modifying the granulator screw configuration during TSG was assessed using conventional (conveying and kneading elements) as well as non-conventional screw elements (tooth-mixing-elements (TME), screw mixing elements (SME) and cutters). Process understanding about the granulation profile obtained using the different screw elements was obtained.

## **MATERIALS AND METHODS**

### **Materials**

To compare PSD of granules produced with FBG and TSG, a model formulation with theophylline anhydrate as API was used. Theophylline anhydrate ( $d_{50} = 66 \mu\text{m}$ ) was purchased from Farma-Química Sur (Malaga, Spain).  $\alpha$ -lactose monohydrate 200M ( $d_{50} = 35 \mu\text{m}$ ) (Caldic, Hemiksem, Belgium) was used as filler for granulation and polyvinylpyrrolidone (PVP) (Kollidon® 30, BASF, Ludwigshafen, Germany) as binder. A premix of theophylline anhydrate and  $\alpha$ -lactose monohydrate (ratio: 30/70, w/w) was granulated with an aqueous PVP solution (5% and 2.5% PVP in granules, based on dry weight, for FBG and TSG trials, respectively). To exclude other influencing parameters, pure  $\alpha$ -lactose monohydrate was granulated with distilled water to investigate the impact of different screw configurations on PSD.

### **Preparation of granules**

Granules were prepared via batch FBG and continuous TSG. For the FBG trials, a laboratory-scale fluid bed granulator (GPCG 1, Glatt, Binzen, Germany) was used (Fig. 2a). A nozzle with a diameter of 1.2 mm was installed top-spray at a height of 26 cm from the distributor plate, and an atomization pressure of 1 bar was used during all experiments. After the initial dry mixing phase (5 min), granulation liquid was sprayed at a rate of 23 g/min. L/S ratio was varied between 0.2, 0.3 and 0.4. Inlet air velocity was set to 8 m/s and shaking of the filter bags was performed every 30 s for a period of 7 s. The inlet air temperature during spraying and drying was 45°C and 60°C, respectively. Granules were dried until an outlet air temperature of 30°C and a product temperature of 40°C was obtained. The batch size was

700 g (based on dry weight). For each run, dry granules were collected and stored for PSD analysis.

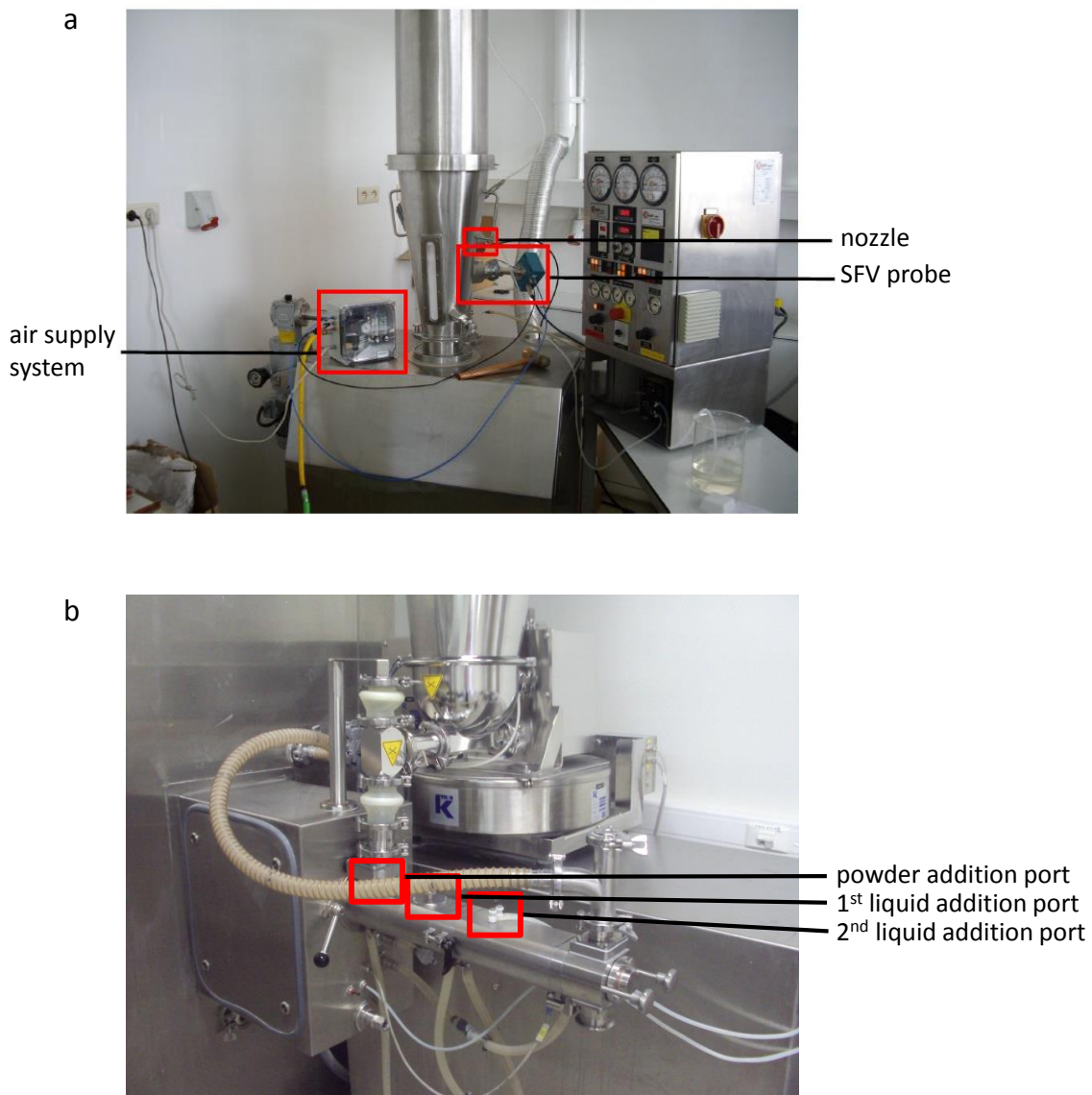

Figure 2: Representation of experimental set-up: fluid bed granulator (a) and twin screw granulator (b).

TSG experiments were performed using a high-shear co-rotating TSG without die plate (Fig. 2b), being the granulation unit of the ConsiGma<sup>TM</sup>-25 unit (a fully continuous tablet manufacturing line). The length-to-diameter ratio was 20:1. In the ConsiGma<sup>TM</sup>-25 unit, the granulation unit is directly linked to a six-segmented fluid bed dryer. As the aim of the current study was to improve process understanding of the granulation step, the fluid bed dryer was not used in order to avoid the impact of dynamic drying on the granule properties.



The barrel of the continuous granulator can be divided into two segments: a feed segment, where powder enters the barrel and consisting of conveying elements to transport the material through the barrel; and a work segment (i.e. variation zone), where the powder is mixed with the granulation liquid by different types of screw elements.

To evaluate the influence of screw configuration on the granulation process, the torque and temperature of the barrel wall at the work segment of the granulator were recorded. The equipment has an in-built torque gauge. At the work segment, the temperature of the barrel wall was controlled by a Pt100 temperature sensor. As the barrel jacket was not divided into different temperature zones, the full length of the barrel was preheated to 25°C. During processing, the powder premix was gravimetrically dosed by a twin screw feeder (KT20, K-Tron Soder, Niederlenz, Switzerland). The powder feed rate and the granulator screw speed were fixed at 20 kg/h and 800 rpm, respectively. Granulation liquid was pumped into the screw chamber using two peristaltic pumps (Watson Marlow, Comwall, UK) and silicon tubing (internal and external diameter of 1.6 and 4.8 mm, respectively) connected to a 1.6 mm nozzle. Liquid was added in front of the variation zone.

For each run, after equilibration of the system, wet granules were collected at the outlet of the granulator, spread on a tray and oven-dried at 40°C during 24h. If granules were milled, dry granules were passed through a 1400µm round-shaped screen using a Quadro comil U10 (Quadro Engineering, Ontario, Canada), which is part of the granule-conditioning module of the ConsiGma<sup>TM</sup>-25 system [15].

To evaluate the impact of screw configuration on the PSD of the granules, different types of screw elements such as conveying elements (CE), kneading elements (K), narrow tooth-mixing-elements (nTME), wide tooth-mixing-elements (wTME), screw mixing elements (SME), and cutters (C) were implemented at the variation zone of the granulator screws. In total, 19 different screw configurations were investigated which are schematically represented in Fig. 3.

## Granule characterisation

### *Particle size analysis*

In order to monitor the PSD of materials during the FBG experiments, an in-line spatial filter velocimetry (SFV) probe (Parsum IPP 70; Gesellschaft für Partikel-, Strömungs- und Umweltmesstechnik, Chemnitz, Germany) was installed in the fluid bed granulator at a height of 20 cm and at approximately 5 cm from the sidewall of the granulator (i.e. between the sidewall of the granulator and the outer part of the spray cone) (Fig. 2a). If the probe was placed in the center of the fluid bed (i.e. below the spray cone), probe fouling by the moist product occurred. Using an internal (20 L/min) and external (3 L/min) air connection, the granules were directed through an aperture (4 mm diameter). Measured raw data were collected via an A/D converter and transferred to a computer. The In-line Particle Probe V7.12a software operated in the Windows XP environment. SFV measurements started and stopped simultaneously with the start and end of fluidization, respectively. During the entire granulation process, SFV data were collected every second, but an average granule size distribution was saved every 10 s. After drying, the batch of granules was collected and subsamples were taken for off-line sieve analysis, as described below.

PSD of oven dried granules produced by TSG was determined via sieve analysis using a Retsch VE 1000 sieve shaker (Haan, Germany). Dry granules (50 g) were placed on the shaker during 5 min at an amplitude of 2 mm using a series of sieves (75, 150, 250, 500, 710, 1000, 1400, 2000 and 3150  $\mu\text{m}$ ). The amount of granules retained on each sieve was determined. The amount of fines and oversized agglomerates were defined as the fractions  $<150$  and  $>1400$   $\mu\text{m}$ , respectively. Using the cumulative PSD curves, the  $d_{10}$ ,  $d_{50}$  and  $d_{90}$  values were interpolated. To describe and compare the width of the PSD resulting from the different screw configurations, the  $d_{90}/d_{10}$  ratio was calculated for each PSD.

### *Liquid distribution*

To investigate the mixing efficiency of different screw configurations, the granulation liquid was colored by the addition of 0.5 % red dye, cochineal red (Fagron, Waregem, Belgium). The samples were collected and dried, and the tracer concentration was determined via UV/VIS-spectroscopy ( $\lambda = 332$  nm). A calibration curve for cochineal red was made over the

range 0 – 60 µg/ml and fitted using linear regression with  $R^2 > 0.99$ . The UV spectroscope used was a Shimadzu UV-1650 PC spectrometer. No significant interference from lactose was observed for the UV absorption reading. The absorbance of the tracer in granules from different size classes (<75 µm, 75-150 µm, 500-710 µm and >2000 µm) was measured separately (300 mg samples per sieve fraction). All tracer concentrations were expressed as the recovery which represents the dye concentration relative to the target strength.

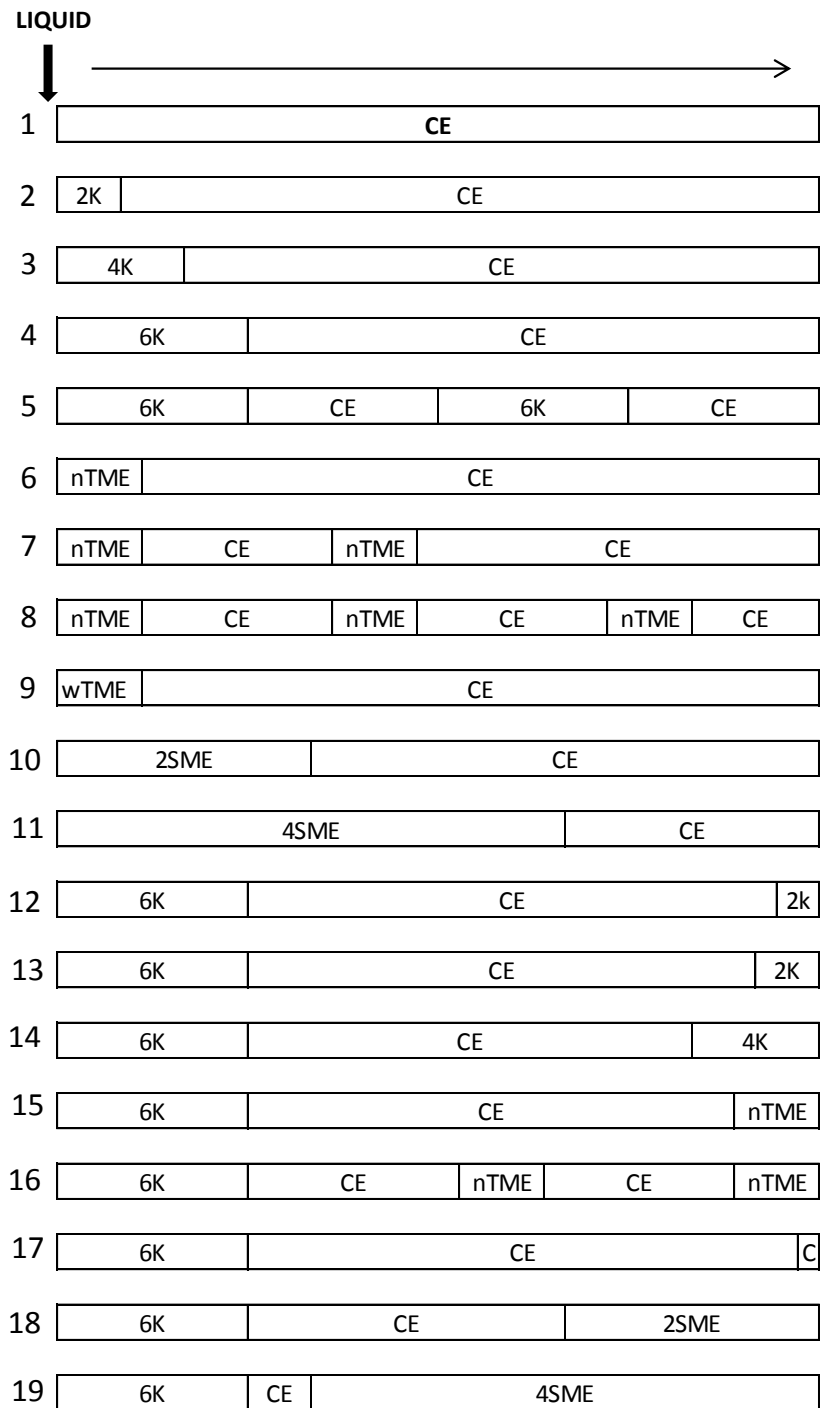

Figure 3: Schematic overview of the screw configurations (variation zone) used in this study: conveying element (CE), narrow (k) and wide (K) kneading element, narrow tooth-mixing-element (nTME), wide tooth-mixing-element (wTME), screw mixing element (SME), and cutter (C).

## RESULTS AND DISCUSSION

### Comparison between FBG and TSG

Fig. 4 represents the evolution of the PSD during the FBG process with a L/S ratio equal to 0.2. During the dry mixing phase, only a slight shift in the PSD was observed: the amount of particles <100  $\mu\text{m}$  slightly increased while the fraction 100-250  $\mu\text{m}$  decreased due to delumping through fluidization of the raw materials. During the spraying phase, a rapid decrease of the fraction <100  $\mu\text{m}$  was observed while the fraction 100-250  $\mu\text{m}$  increased. After 2 min of spraying, also the fractions 250-500  $\mu\text{m}$  and 500-710  $\mu\text{m}$  increased. This shows that granule growth was achieved by collisions between (partially) wetted granules (i.e. coalescence) or granules and powders (i.e. layering), resulting in larger granules composed of several particles. During the first 18 min of the drying phase, the amount of particles 250-500  $\mu\text{m}$  and 500-710  $\mu\text{m}$  increased, indicating further granule growth. No agglomerates larger than 710  $\mu\text{m}$  were obtained. During the remaining part of the drying phase, the amount of particles <100  $\mu\text{m}$  and 100-250  $\mu\text{m}$  increased again as granule strength was not sufficient to overcome breakage or attrition [18].

PSD results for granules produced by FBG at different L/S ratios (0.2, 0.3 and 0.4) are shown in Fig. 5. For all L/S ratios, narrow and monomodal PSD of granules were obtained at the end of the drying phase. By increasing the L/S ratio from 0.2 to 0.4, the fraction 250-500  $\mu\text{m}$  increased as more powder materials could be captured in the granules due to higher probability of contact with liquid and/or wetted surfaces. Furthermore, during the drying phase no attrition was observed at a L/S of 0.4. Typical PSD results for granules produced by TSG are also shown in Fig. 5. A screw configuration consisting of 2 kneading zones of 6 kneading elements each at 60 degrees was used (Fig. 3, screw configuration 5). Hereby, it is important to mention that, compared to FBG trials, for TSG experiments the binder concentration was lowered to 2.5% and the L/S ratio was decreased to 0.08-0.10 as otherwise too much (>50%) oversized agglomerates (> 1400  $\mu\text{m}$ ) were produced. In contrast to FBG where a narrow and monomodal PSD was obtained, granules produced via TSG typically showed a wide and multimodal PSD, in agreement with earlier research work [2-4, 7-14].

Figure 4: Evolution of PSD during FBG process (L/S ratio = 0.2): dry mixing (a), spraying (b) and drying (c) phase.

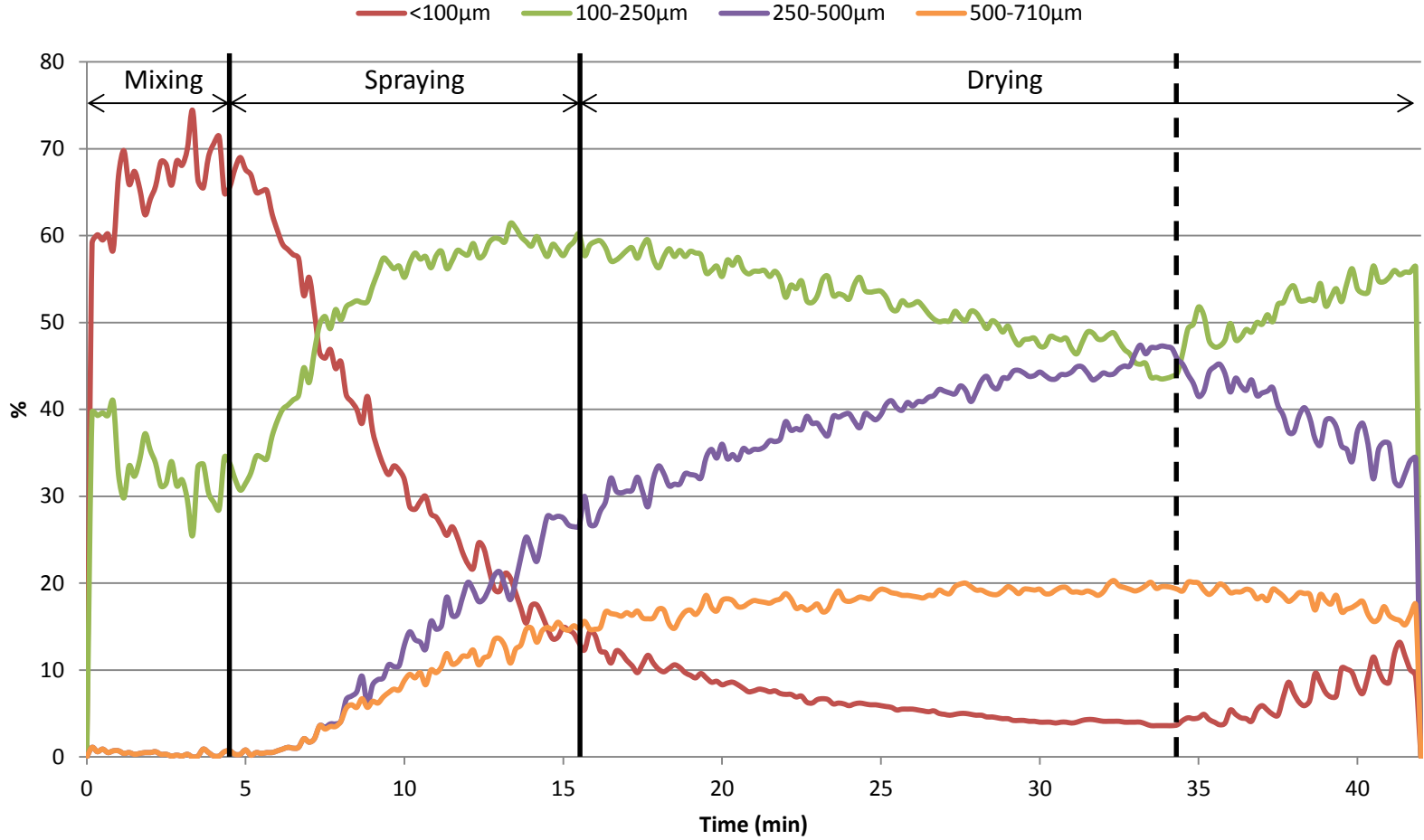

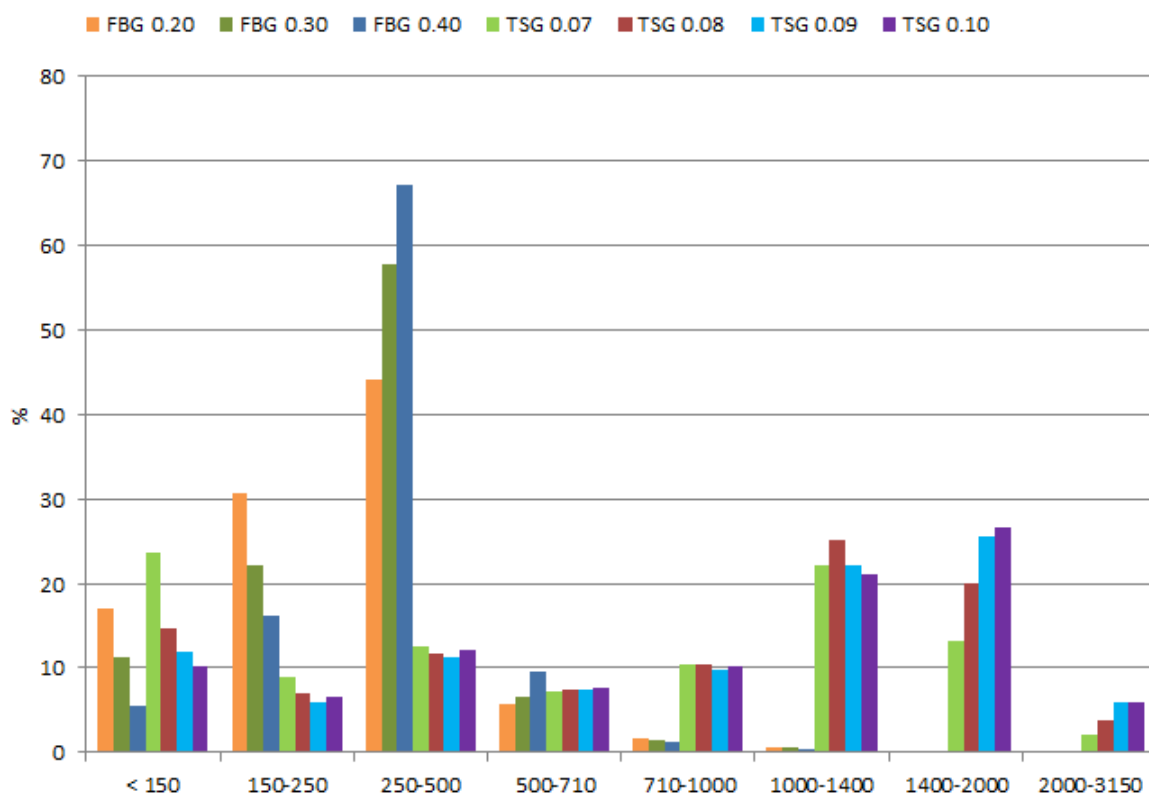

Figure 5: PSD results for granules produced by FBG (L/S ratio: 0.20, 0.30 and 0.40) and TSG (L/S ratio: 0.08, 0.09 and 0.10) using 2 kneading zones of 6 kneading elements each (60 degrees stagger angle).

As described in the section Materials and methods, the granule conditioning unit of the ConsiGma<sup>TM</sup>-25 consists of a milling system in order to reduce oversized agglomerates. However, by crushing the oversized agglomerates during milling not only granules with a desired size (150-1000  $\mu\text{m}$ ) are formed but also extra fines (<math>< 150 \mu\text{m}</math>) are created. This is illustrated in Fig. 6 as the amount of fines drastically increased from 28% to 53% at 300 and 3000 rpm, respectively, which results in inferior flow properties. This shows the importance of controlling the PSD of the granules directly inside the screw chamber of the TSG instead of correcting the PSD by milling after drying.

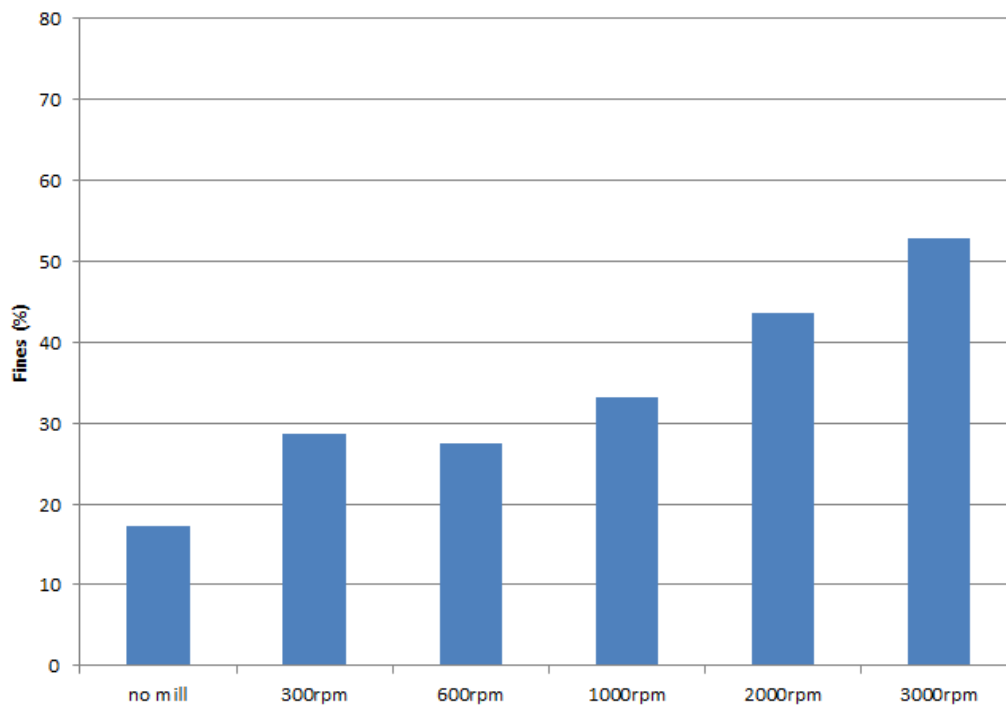

Figure 6: Percentage of fines in function of milling speed.

It is obvious that better control over the PSD during TSG is desirable to minimize downstream processing problems. A wider size distribution increases the segregation tendency during granule handling, transfer, blending as well as tablet compression or capsule filling, resulting in a higher risk of content non-uniformity. Additionally, generating a narrow PSD will improve granule drying uniformity, as opposed to overdrying of fines and underdrying of oversized agglomerates [19]. El Hagrasy et al. [3] stated that the equipment design flexibility of TSGs, particularly with a multitude of screw configurations and modular barrel designs, can be used to obtain granules with a wide range of morphological and physical attributes, as well as provide more opportunities for particle design than those offered by conventional granulation equipment. To optimize the PSD after TSG, the effect of modifying the granulator screw configuration on the PSD was investigated and described in the following sections.



## Granulation with conveying and kneading elements

Generally, in hot melt extrusion processes, conveying elements are used to convey material from the inlet to the outlet of the screw chamber (Fig. 1a). Hereby, a minimal of mechanical energy is imparted on the material [6]. Although the cross section of the self-wiping profile is not affected by the pitch, the free volume in a screw channel is higher using a larger screw pitch [20]. In this study, all conveying elements had a pitch of 0.5D. Fig. 7 shows PSD results for granules produced at various L/S ratios using only conveying elements (Fig. 3, screw configuration 1). Multimodal PSDs with a high amount of fines and a small fraction of oversized agglomerates were obtained. It is clear that smaller particles were agglomerated into larger particles by increasing the L/S ratio. For all L/S ratios, the fraction 150-1000  $\mu\text{m}$  which can be considered as the interesting fraction for tableting, remained fairly constant (i.e. between 23% and 26% for all L/S ratios).

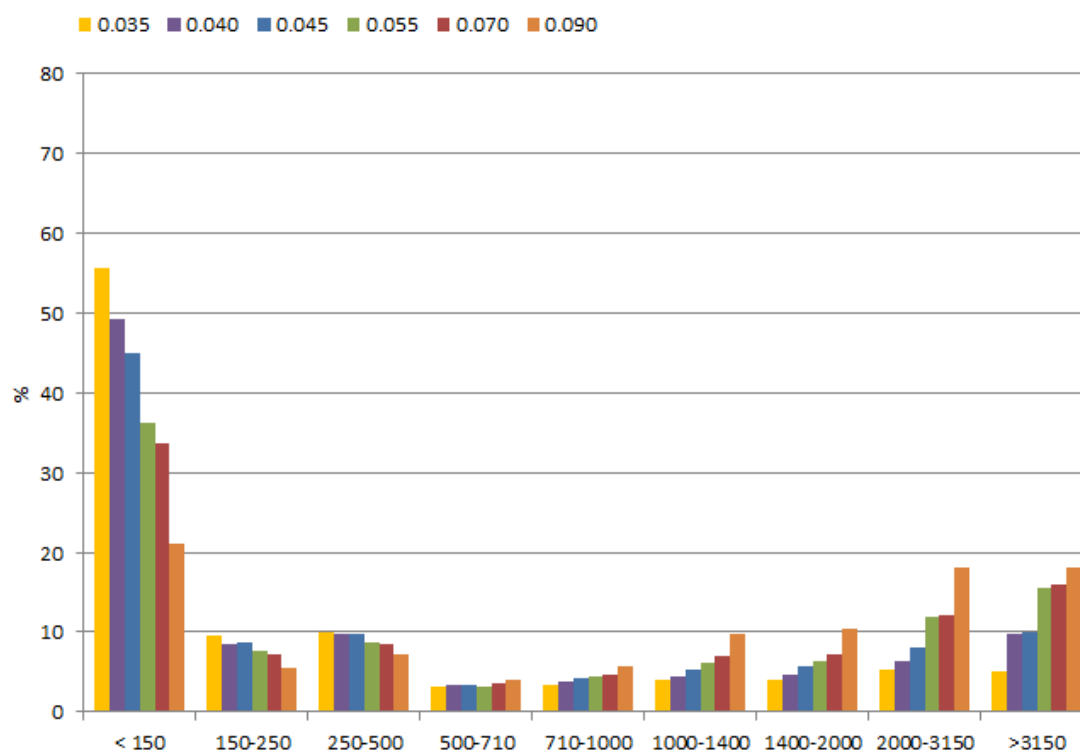

Figure 7: PSD results for granules produced with conveying elements only at different L/S ratios.

These results are in agreement with El Hagrasy and Litster [13] and Dhenge et al. [21]. El Hagrasy and Litster [13] described that agglomerates are formed in the conveying section by

drop-granulation as the liquid is dripped into the barrel, producing ungranulated fines and wet agglomerates. At higher L/S ratios, more powder was wetted and covered by liquid, resulting in larger nuclei.

The impact of replacing the conveying elements in the variation zone of the screw design with a more energy-intensive kneading element was investigated (Fig. 1b). In contrast to the conveying element, kneading elements generally operate fully filled with material, causing material densification in this zone. Fig. 8 shows PSD results for granules produced at different L/S ratios using 2 kneading zones of 6 kneading elements, each at a stagger angle of 60 degrees (Fig. 3, screw configuration 5). A large fraction of fines was found at low L/S ratios due to the lack of binder liquid. For L/S ratios between 0.035 and 0.070, the fraction of 150-1400  $\mu\text{m}$  granules remained fairly constant (i.e. between 51.2 and 64.3%). For these L/S ratios, the most striking changes were detected for the fines and oversized fraction: the higher the L/S ratio, the lower the amount of fines (from 40.2 to 7.7% for L/S ratio 0.035 and 0.070, respectively) and the higher the amount of oversized agglomerates (from 3.4 to 31.8% for L/S ratio 0.035 and 0.070, respectively). Since more liquid was available during granulation, granule growth was enhanced as the particles coalesced more efficiently and less ungranulated material or small granules remained. A further increase of the L/S ratio to 0.090 and 0.095 resulted in complete agglomeration of lactose as the amount of fines was negligible (i.e. 0.8% at L/S ratio 0.095). At the same time, the oversized fraction became more abundant (e.g. 77.0% at L/S ratio 0.095) due to overwetting of the material and thus a higher liquid saturation within the granules. Hence, a narrower and monomodal PSD could be achieved at higher L/S ratio, in agreement with earlier research work [3, 11, 22]. This was also indicated by the  $d_{90}/d_{10}$  ratio which was 27.4 and 3.2 for L/S ratio 0.035 and 0.095, respectively. However, these granules were not suitable for tableting as a significant fraction of the granules were larger than the maximum size required for tableting (i.e. 1000  $\mu\text{m}$ ).

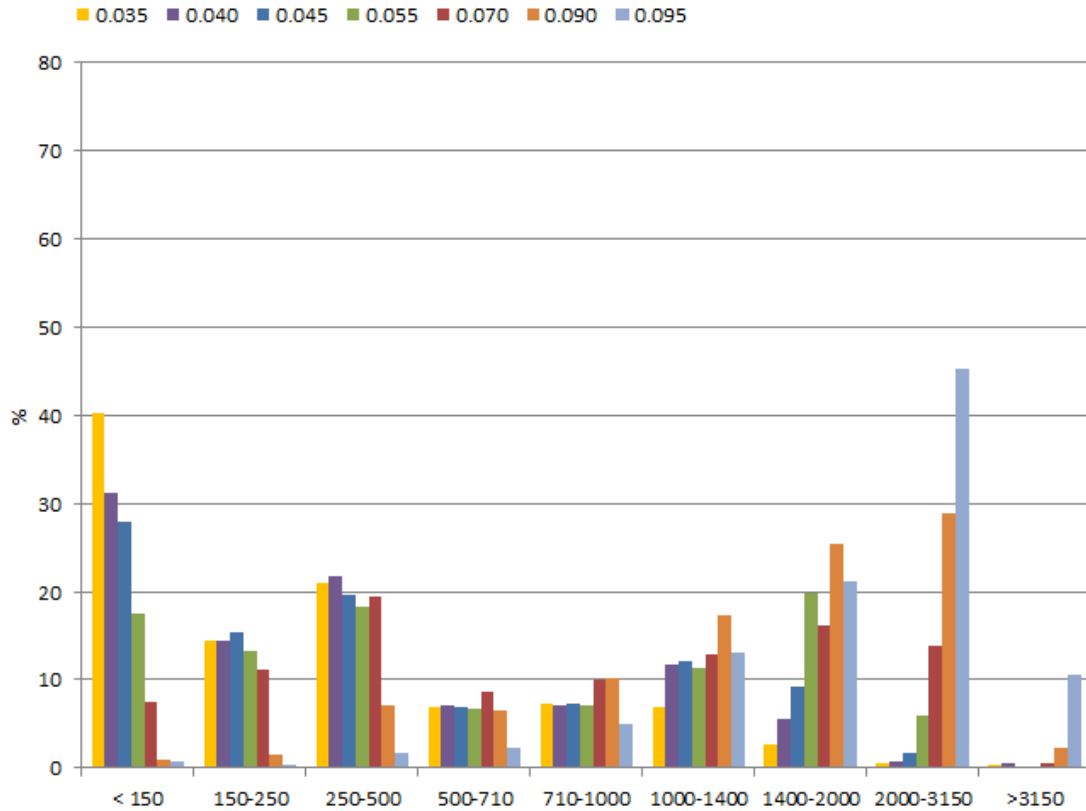

Figure 8: PSD results for granules produced with 2 kneading zones of 6 kneading elements each (60 degrees stagger angle) at different L/S ratios.

Fig. 9 depicts the changes in PSD with increasing number of kneading elements at 60 degrees stagger angle (i.e. 0, 2, 6 and 12) and at a constant L/S ratio of 0.090 (Fig. 3, screw configuration 1, 2, 4 and 5). It is evident that the amount of fines is correlated with the number of kneading elements: inclusion of more kneading segments induced the formation of larger agglomerates. Addition of a second kneading block further contributed to powder agglomeration. The kneading elements in the screw design increased both shear and compressive forces on the wetted powder mass inside the barrel [16, 23] and therefore improved particle packing or densification and consolidation of the powder mass [10]. It should be noted that the >3150 µm fraction became negligible (i.e. <3%) when kneading elements were used. This indicates that due to the dispersive character of the kneading elements, the initially overwetted lumps were subjected to breakage by shearing of the materials between the tip of the kneading elements and the barrel surface. At the same time, many of the ungranulated fines were captured into granules by layering. By increasing

the number of kneading elements from 2 to 12,  $d_{90}/d_{10}$  ratio was lowered from 20.5 to 5.3. However, using more kneading elements the PSD was shifted to the right (i.e.  $d_{50}=1543 \mu\text{m}$ ).

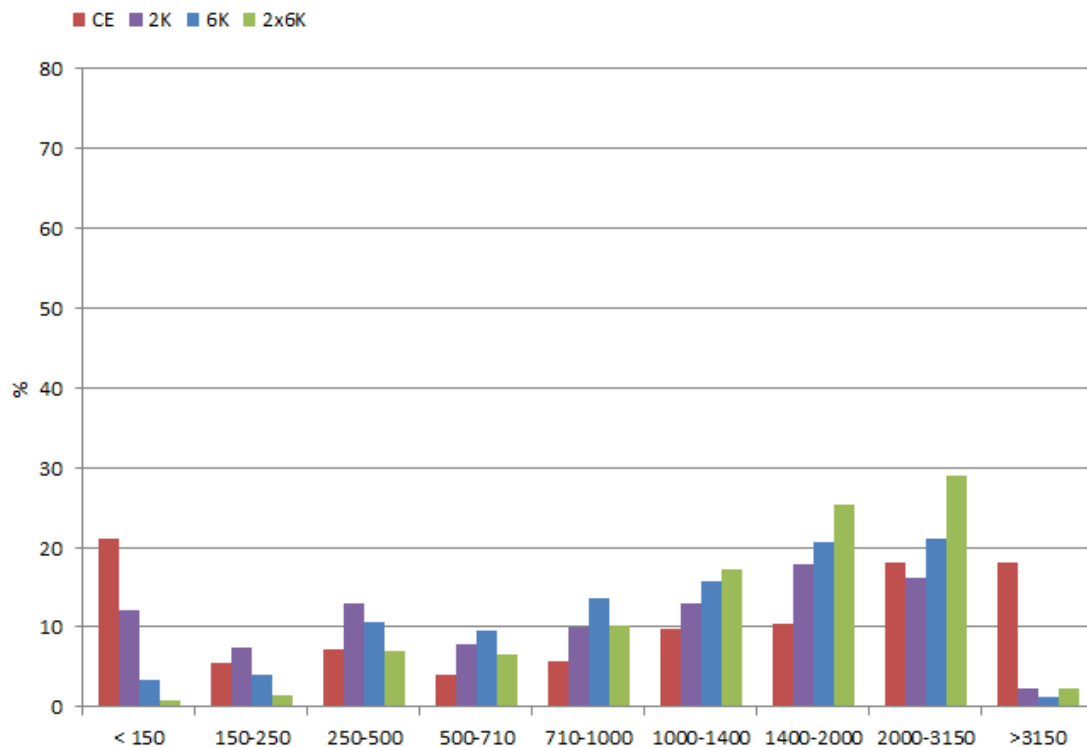

Figure 9: PSD results for granules produced with various number of kneading elements (60 degrees stagger angle) at 0.09 L/S ratio: conveying elements only (CE), 1 kneading zone of 2 and 6 kneading elements (1x2 and 1x6, respectively) and 2 kneading zones of 6 kneading elements each (2x6).

### Distribution of granulation liquid

Fig. 10 shows the distribution of dye in function of sieve fractions for granules produced with different screw configurations: conveying elements only, 1 kneading zone of 4 and 6 kneading elements, 2 kneading zones with 6 kneading elements each (Fig. 3, screw configuration 1, 2, 3 and 5). Kneading elements were staggered at 60 degrees. When only conveying elements were used, the dye distribution was poor and highly dependent on the granule size. As the granule size increased, there was an incremental increase in the dye concentration, reaching a maximum at the largest size fraction. This showed that large nuclei rich in liquid were formed without redistribution of granulation liquid. These results are in agreement with El Hagrasy and Litster [13] Dhenge et al. [24]. The latter described that

pumping of granulation liquid onto the top of the granulator screws causes the liquid to drip onto the powder mass, forming immersion type of nuclei (big, wet, loose lumps or nuclei of powder) rather than a distribution mechanism. This is attributed to the combined effect of relatively large-size droplets with respect to the particle size, as well as the lack of shear forces. Hence, these agglomerates were formed on the conveying elements by simple wetting of the powder mass. They were not exposed to further high shearing from the kneading elements.

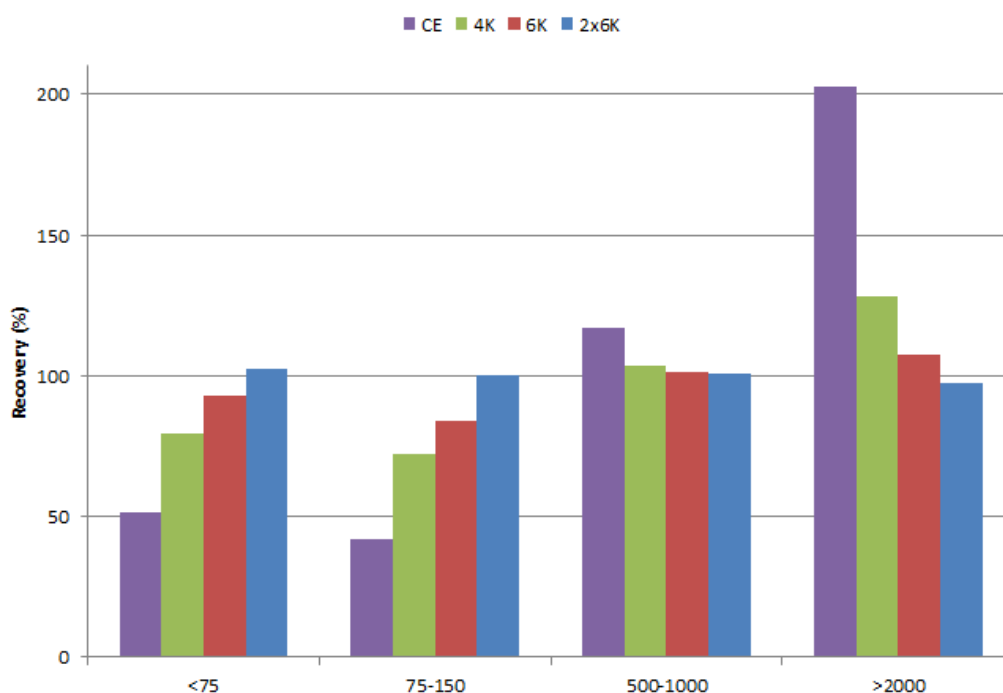

Figure 10: Recovery (%) of dye in function of sieve fraction for granules produced with various number of kneading elements (60 degrees stagger angle): conveying elements only (CE), 1 kneading zone of 2 and 6 kneading elements (1x2 and 1x6, respectively) and 2 kneading zones of 6 kneading elements each (2x6).

When kneading elements were incorporated in the granulator screws, the large agglomerates formed by the conveying elements were sheared, compressed and deformed. This may have squeezed the liquid binder from the granules towards their surfaces. Subsequently, the liquid was distributed for coalescence and growth [18]. When 4 and 6 kneading elements were used, the difference in dye concentration between the smallest and largest size fraction was 49% and 14%, respectively. The liquid distribution improved with

longer kneading sections because of the additional exchange of granulation liquid between the wet surface of consolidated granules and the ungranulated fines along the axial direction of material flow [13]. In case 2 kneading zones of 6 kneading elements each were applied, a homogeneous distribution of dye over the different granule size fractions was obtained as the recovery of liquid over the different sieve fractions only varied 5%.

El Hagrasy et al. [3] identified the inadequacy of the kneading elements in distributing the granulation liquid as a potential cause for the wide PSD observed and stated that improving the liquid distribution inside the granulator would enhance the properties of the granules obtained, especially with respect to size. However, Vercruysse et al. [14] used NIR chemical imaging to monitor the moisture distribution for granules produced by TSG and described that although moisture uniformity could be achieved by implementing a sufficient number of kneading elements on the granulator screws, PSD results showed wide and bimodal profiles. Based on this observation, it was concluded that the typical bimodal PSD for granules produced by TSG was not mainly related to the insufficient mixing of powder and liquid phase during the short residence time of material inside the barrel, but rather to the granulation mechanism inherent to the technique. Furthermore, Fonteyne et al. [25] visualized the binder distribution in granules produced by TSG. No binder-rich zones were detected, indicating that the binder was homogeneously distributed within the granules. So, the results from Fig. 10 contribute to the statements made by Vercruysse et al. [14] and Fonteyne et al. [25].

### **Granulation with tooth-mixing-elements (TME) and screw mixing elements (SME)**

Alternative to the conventional conveying and kneading elements, the feasibility of tooth-mixing-elements (TME) (Fig. 1c and d) and screw mixing elements (Fig. 1e) for TSG was investigated. TMEs used in this study were neutrally conveying. PSD results of granules produced at L/S ratio of 0.11 with various narrow TMEs (0, 1, 2 and 3) are shown in Fig. 11 (Fig. 3, screw configuration 6, 7 and 8). If multiple TMEs were used, they were separated by a conveying element ( $L=1.5D$ ). By incorporating a TME in the screws, the amount of fines at an L/S ratio of 0.045 was lowered from 40.9 to 19.3%. Increasing the number of TMEs did not further reduce the amount of fines. However, the  $>1400\mu\text{m}$  fraction decreased from 20.2 to 10.4% by implementing an additional TME on the screws. Granulation with 3 TMEs did not

have an added value regarding PSD, compared to 2 TMEs. The width of the TME was also varied (Fig. 1d) (Fig. 3, screw configuration 9). Using a single wide TME for granulation instead of a narrow TME reduced the amount of fines from 19.3 to 11.1%, while the >1400 $\mu\text{m}$  fraction increased from 20.2 to 35.8%, indicating further granule growth. Increasing the number of wide TMEs was not possible as due to their non-forwarding character and their increased width high (up to 10 Nm) and unstable torque values were obtained.

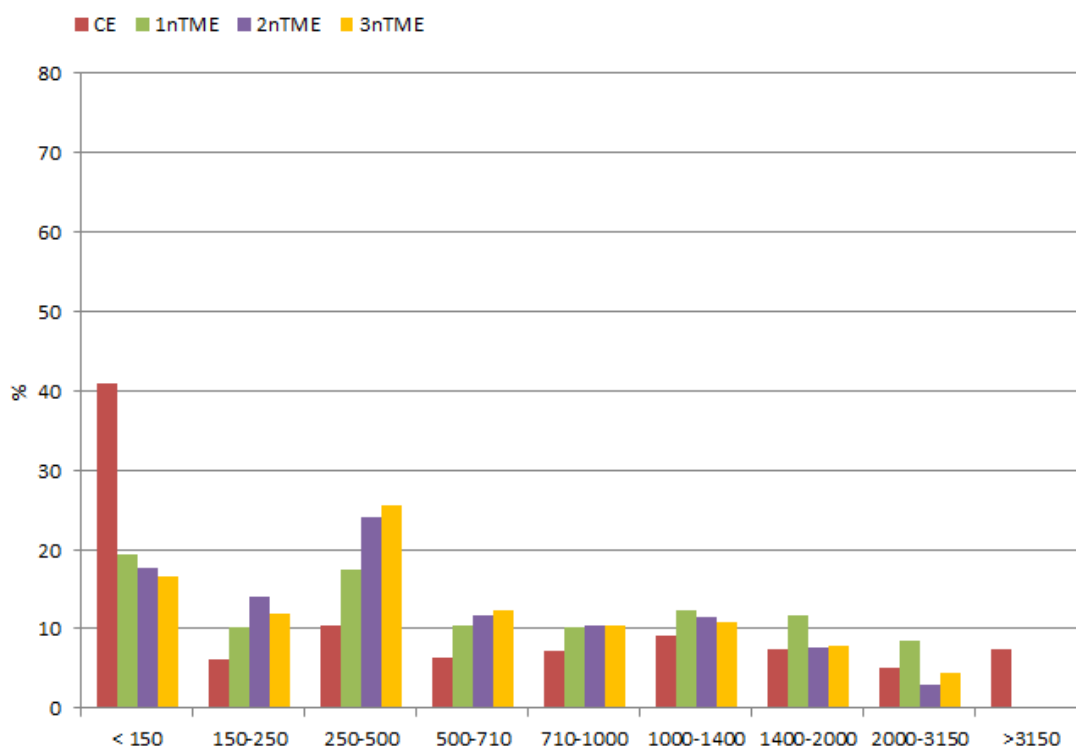

Figure 11: PSD results for granules produced at L/S ratio 0.045 with conveying elements only (CE), 1, 2 and 3 narrow TME (1nTME, 2nTME and 3nTME, respectively).

The geometry of SMEs is based on conventional conveying elements. However, due to the distinct design of the flight tip, the backflow, residence time and distributive mixing of material at the SME is increased [26]. Unlike conventional kneading elements, SMEs do not generate high-sheared regions as they have a higher positive-transport capacity compared to kneading elements [27]. This was evident from the lower and stable torque values during processing with SMEs. When SMEs were incorporated in the granulator screws, limited differences in PSDs were detected compared to conveying elements (Fig. 12) (Fig. 3, screw configuration 10 and 11). Using 2 SMEs for granulation at a L/S ratio of 0.07 diminished the

amount of fines from 33.7% to 17.7%, while the amount of lumps ( $>3150\mu\text{m}$ ) increased from 15.9 to 17.5%. Placing 2 additional SMEs did not further affect the amount of fines, but decreased the lumps from 17.5 to 7.8%. Hence SME maintained a higher fraction of fines compared to the kneading elements described above.

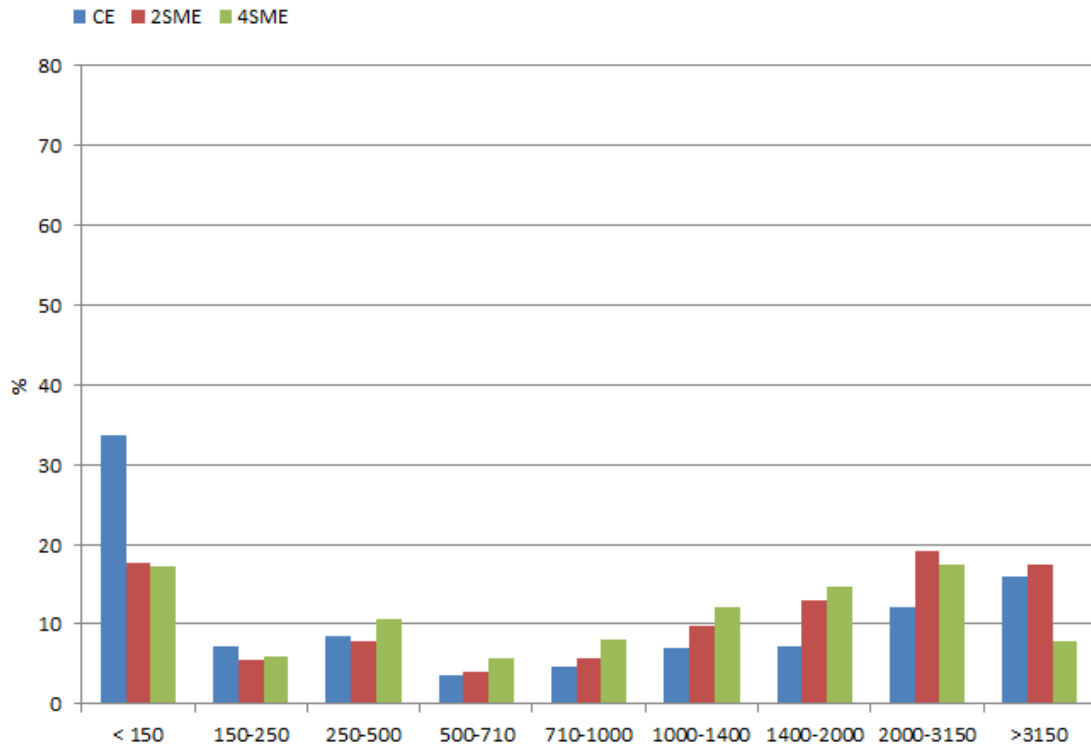

Figure 12: PSD results for granules produced at L/S ratio 0.07 using conveying elements only (CE), 2 SME and 4 SME.

### Resizing of granules by modifying the final screw section

In this section, the effect of changing the final section of the screw design on the PSD is described. Resizing of granules was approached by implementing additional kneading elements at the end of the granulator screws, varying their number (0, 2 and 4), width (narrow and wide) and stagger angle (30, 60 and 90 degrees) as these determine the operating principle of the kneading zone (Fig. 3, screw configuration 12, 13 and 14). When 2 narrow kneading elements ( $L=D/6$ ) at  $30^\circ$  angle were built into the final screw section no changes in PSD were detected compared to only conveying elements in the final section (Fig. 13). However, using 2 wide ( $L=D/4$ ) kneading elements in the final section, further agglomeration was detected: the  $>1400\mu\text{m}$  fraction increased from 21 to 45%, respectively.



Due to larger width of the kneading elements the probability of particles being forced into the shear gap between the kneading elements and the barrel wall is higher [20], thus inducing agglomeration via layering whereby fines adhere to larger granules. Expanding the number of wide kneading elements (i.e. from 2 to 4) resulted in even more agglomeration (i.e. 51% >1400 $\mu$ m). When the kneading elements were positioned at 60 or 90° stagger angle, only limited differences in PSD were obtained compared to a screw design with only transport elements at the end of the granulator screws (Fig. 14). This is linked to the larger axial opening between the kneading discs at the higher staggering angle.

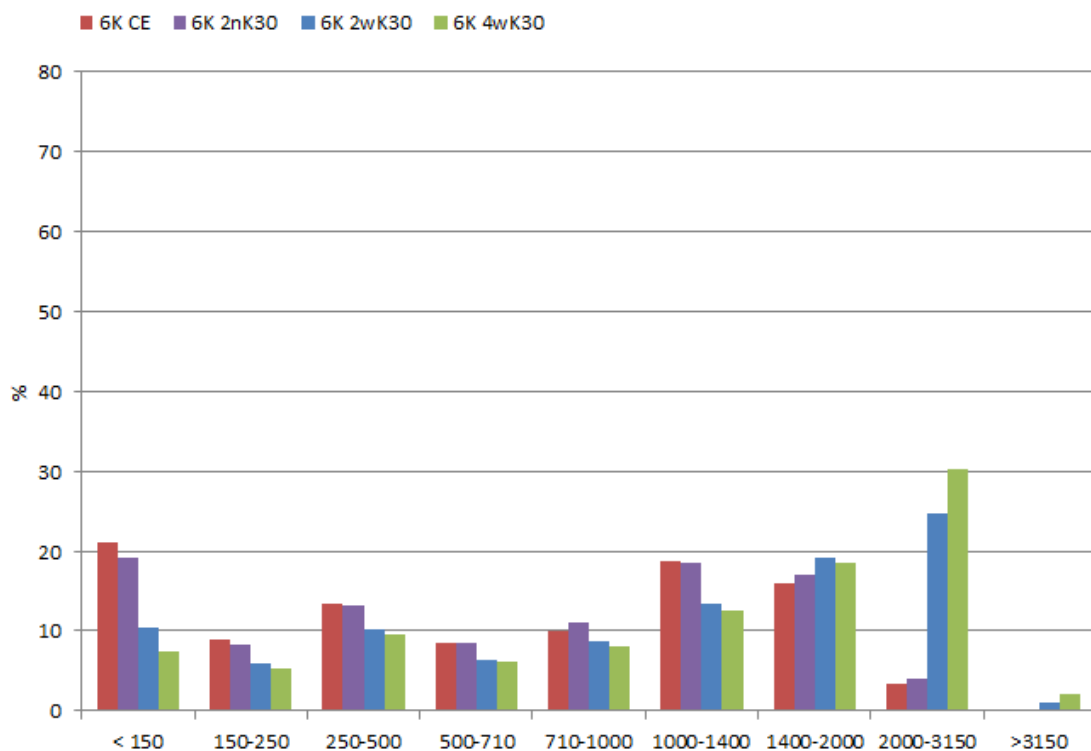

Figure 13: PSD results for granules produced with 1 kneading zone of 6 kneading elements at 60 degrees combined with different screw end variations: conveying elements only (CE), 2 narrow and wide kneading elements at 30 degrees stagger angle (2nK30 and 2wK30, respectively) and 4 wide kneading elements at 30 degrees stagger angle (4wK30).

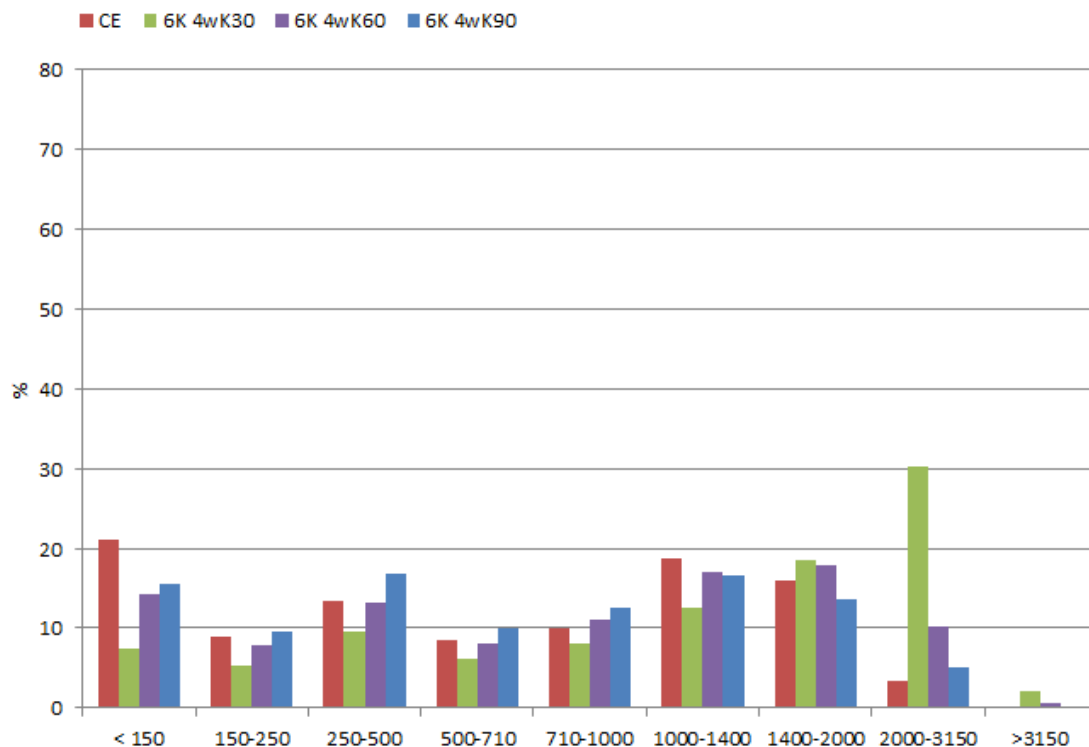

Figure 14: PSD results for granules produced with different screw end variations: conveying elements only (CE), 4 wide kneading elements at 30, 60 and 90 degrees stagger angle (4wK30, 4wK60 and 4wK90, respectively).

As additional kneading elements at the screw end did not shift the PSD towards the size fractions suitable for tableting, alternative screw elements (i.e. cutters, narrow TME and SME) (Fig. 1c, e and f) were also tested at the end of the screw (Fig. 3, screw configuration 15, 16 and 17). However, TMEs and cutters did not yield the appropriate PSD. Using cutter elements more oversized agglomerates were formed as these elements are neutrally conveying elements, thus holding up the material, increasing the pressure at the end of the screw chamber and inducing further aggregation of particles (results not shown). Furthermore, high and variable torque profiles were recorded using this screw configuration. When a single narrow TME was implemented at the end of the screw, a reduction of the >1000µm fraction was observed (i.e. from 44.7 to 29.3 %). However, a second TME did not have an added value: although the >1000µm fraction was further lowered to 20.4% it also contained more fines (30.8%, vs. 19.2% using a final screw section with only conveying elements).

Continuous granulation using a screw with a single kneading zone of 6 kneading elements in combination with 2 or 4 SMEs in the final screw section (Fig. 3, screw configuration 18 and 19) resulted in low and stable torque values due to the conveying capacity of SMEs. This combination of screw elements also affected the granule size as 4 SMEs after the kneading zone increased the fraction between 150 and 1400  $\mu\text{m}$  to 82.2% (vs. 53.8% using only kneading elements). In combination with 2 and 4 SMEs, the  $d_{90}/d_{10}$  ratio was reduced from 23.7 (conveying elements) to 9.7 and 7.0, respectively (Fig. 15).

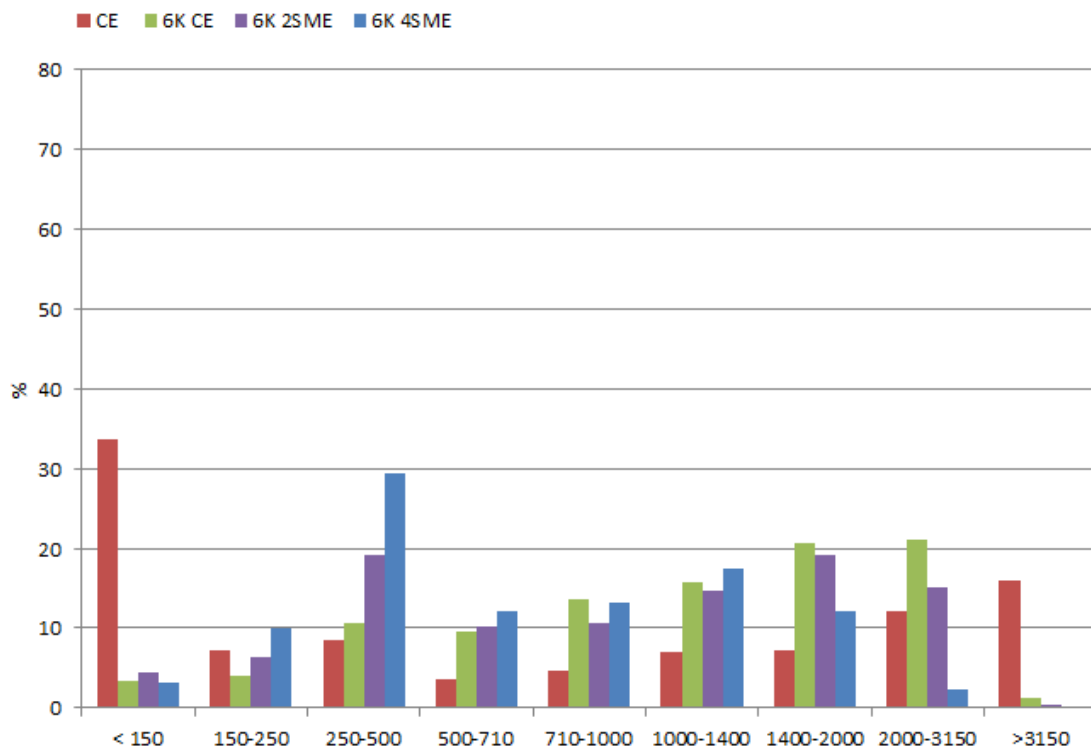

Figure 15: PSD results for granules produced at L/S ratio 0.07 using conveying elements only (CE), 1 kneading zone of 6 kneading elements at 60 degrees combined with conveying elements (1x6K CE), 2 SME (1x6K 2SME) and 4 SME (1x6K 4SME).

Although 4 SMEs only slightly reduced the  $d_{90}/d_{10}$  ratio compared to 2 SMEs,  $d_{50}$  shifted from 980 to 608  $\mu\text{m}$ , indicating that - for this granulation procedure - breakage and layering were the dominant granulation rate processes as the amount of fines remained low. Similar observations were made when 2 kneading zones of 6 kneading elements were used in combination with SMEs (results not shown).

**CONCLUSIONS**

This study emphasized the impact of the granulator screw configuration in a TSG on the PSD of granules. Using screw elements adapted from hot melt extrusion processes, wide and multimodal PSDs were obtained. However, the process yield could be improved by combining these elements with SME. For these screw configurations, PSD was narrower and  $d_{50}$  values were lower, which resulted in a more appropriate PSD for tableting. Furthermore, because of their conveying capacity, stable torque profiles were detected for SME. In order to fully evaluate the potential of using SME for TSG, several formulations and other critical quality attributes besides PSD (e.g. flow properties, shape, density) should be determined and evaluated.

**ACKNOWLEDGEMENTS**

The authors would like to thank GEA Pharma Systems, for kindly providing the wide TME and SME.

**REFERENCES**

- [1] C. Vervaet, J.P. Remon, Continuous granulation in the pharmaceutical industry, *Chemical Engineering Science*, 60 (2005) 3949-3957.
- [2] D. Djuric, P. Kleinebudde, Continuous granulation with a twin-screw extruder: Impact of material throughput, *Pharmaceutical Development and Technology*, 15 (2010) 518-525.
- [3] A.S. El Hagrasy, J.R. Hennenkamp, M.D. Burke, J.J. Cartwright, J.D. Litster, Twin screw wet granulation: Influence of formulation parameters on granule properties and growth behavior, *Powder Technology*, 238 (2012) 108-115.
- [4] E.I. Keleb, A. Vermeire, C. Vervaet, J.P. Remon, Twin screw granulation as a simple and efficient tool for continuous wet granulation, *International Journal of Pharmaceutics*, 273 (2004) 183-194.
- [5] U. Shah, Use of a modified twin-screw extruder to develop a high-strength tablet dosage form, *Pharmaceutical Technology*, 6 (2005) 52-66.
- [6] M.R. Thompson, J. Sun, Wet Granulation in a twin-screw extruder: implications of screw design, *Journal of pharmaceutical sciences*, 99 (2010) 2090-2103.
- [7] B. Van Melkebeke, C. Vervaet, J.P. Remon, Validation of a continuous granulation process using a twin-screw extruder, *International Journal of Pharmaceutics*, 356 (2008) 224-230.
- [8] J. Vercruyse, D.C. Diaz, E. Peeters, M. Fonteyne, U. Delaet, I. Van Assche, T. De Beer, J.P. Remon, C. Vervaet, Continuous twin screw granulation: Influence of process variables on granule and tablet quality, *European Journal of Pharmaceutics and Biopharmaceutics*, 82 (2012) 205-211.
- [9] D. Djuric, P. Kleinebudde, Impact of screw elements on continuous granulation with a twin-screw extruder, *Journal of Pharmaceutical Sciences*, 97 (2008) 4934-4942.
- [10] R.M. Dhenge, J.J. Cartwright, M.J. Hounslow, A.D. Salman, Twin screw wet granulation: Effects of properties of granulation liquid, *Powder Technology*, 229 (2012) 126-136.

- [11] R.M. Dhenge, R.S. Fyles, J.J. Cartwright, D.G. Doughty, M.J. Hounslow, A.D. Salman, Twin screw wet granulation: Granule properties, *Chemical Engineering Journal*, 164 (2010) 322-329.
- [12] D. Djuric, B. Van Melkebeke, P. Kleinebudde, J.P. Remon, C. Vervaet, Comparison of two twin-screw extruders for continuous granulation, *European Journal of Pharmaceutics and Biopharmaceutics*, 71 (2009) 155-160.
- [13] A.S. El Hagrasy, J.D. Litster, Granulation rate processes in the kneading elements of a twin screw granulator, *Aiche Journal*, 59 (2013) 4100-4115.
- [14] J. Vercruyssen, M. Toiviainen, M. Fonteyne, N. Helkimo, J. Ketolainen, M. Juuti, U. Delaet, I. Van Assche, J.P. Remon, C. Vervaet, T. De Beer, Visualization and understanding of the granulation liquid mixing and distribution during continuous twin screw granulation using NIR chemical imaging, *European Journal of Pharmaceutics and Biopharmaceutics*, 86 (2014) 383-392.
- [15] J. Vercruyssen, U. Delaet, I. Van Assche, P. Cappuyns, F. Arata, G. Caporicci, T. De Beer, J.P. Remon, C. Vervaet, Stability and repeatability of a continuous twin screw granulation and drying system, *European journal of pharmaceutics and biopharmaceutics*, 85 (2013) 1031-1038.
- [16] R.M. Dhenge, J.J. Cartwright, D.G. Doughty, M.J. Hounslow, A.D. Salman, Twin screw wet granulation: Effect of powder feed rate, *Advanced Powder Technology*, 22 (2011) 162-166.
- [17] K.T. Lee, A. Ingram, N.A. Rowson, Comparison of granule properties produced using twin screw extruder and high shear mixer: A step towards understanding the mechanism of twin screw wet granulation, *Powder Technology*, 238 (2013) 91-98.
- [18] S.M. Iveson, J.D. Litster, K. Hapgood, B.J. Ennis, Nucleation, growth and breakage phenomena in agitated wet granulation processes: a review, *Powder Technology*, 117 (2001) 3-39.

- [19] J.W. Carson, Overcoming particle segregation in the pharmaceutical and cosmetics industries, *Drug development and industrial pharmacy*, 14 (1988) 2749-2758.
- [20] H.J. Sämann, Screw elements for co-rotating, closely intermeshing, twin-screw extruders, in: K. Kohlgrüber (Ed.) *Co-rotating twin-screw extruders*, 2007, 215-235.
- [21] R.M. Dhenge, K. Washino, J.J. Cartwright, M.J. Hounslow, A.D. Salman, Twin screw granulation using conveying screws: Effects of viscosity of granulation liquids and flow of powders, *Powder Technology*, 238 (2013) 77-90.
- [22] W.D. Tu, A. Ingram, J. Seville, Regime map development for continuous twin screw granulation, *Chemical Engineering Science*, 87 (2013) 315-326.
- [23] C. Schmidt, P. Kleinebudde, Influence of the granulation step on pellets prepared by extrusion/spheronization, *Chemical and Pharmaceutical Bulletin*, 47 (1999) 405-412.
- [24] R.M. Dhenge, J.J. Cartwright, M.J. Hounslow, A.D. Salman, Twin screw granulation: Steps in granule growth, *International Journal of Pharmaceutics*, 438 (2012) 20-32.
- [25] M. Fonteyne, A.L. Fussell, J. Vercruyssen, C. Vervaet, J.P. Remon, C. Strachan, T. Rades, T. De Beer, Distribution of binder in granules produced by means of twin screw granulation, *International Journal of Pharmaceutics*, 462 (2014) 8-10.
- [26] T. Ishikawa, T. Amano, S.I. Kihara, K. Funatsu, Flow patterns and mixing mechanisms in the screw mixing element of a co-rotating twin-screw extruder, *Polymer Engineering and Science*, 42 (2002) 925-939.
- [27] A.S. Fard, P. Anderson, Simulation of distributive mixing inside mixing elements of co-rotating twin-screw extruders, *Computers & Fluids*, 87 (2013) 79-91.





# 4

## **USE OF A CONTINUOUS TWIN SCREW GRANULATION AND DRYING SYSTEM DURING FORMULATION DEVELOPMENT AND PROCESS OPTIMIZATION**

Parts of this chapter are submitted to European Journal of Pharmaceutics and Biopharmaceutics:

J. Vercruyse, E. Peeters, M. Fonteyne, P. cappuyns, U. Delaet, I. Van Assche, T. De Beer, J.P. Remon, C. Vervaet, Use of a continuous twin screw granulation and drying system during formulation development and process optimization.

**Abstract**

Since small scale is key for successful introduction of continuous techniques in the pharmaceutical industry (i.e. to allow its use during formulation development and process optimization), it is essential to determine if the product quality is similar when small quantities of materials are processed compared to the continuous processing of larger quantities. Therefore, the aim of this study was to investigate whether material processed in a single cell of the six-segmented fluid bed dryer of the ConsiGma™-25 system (a continuous twin screw granulation and drying system introduced by GEA Pharma Systems, Wommelgem, Belgium) is predictive of granule and tablet quality during full-scale manufacturing (i.e. when all drying cells are filled). Furthermore, the performance of the ConsiGma™-1 system (a mobile laboratory unit) was evaluated and compared to the ConsiGma™-25 system.

A premix of two active ingredients, powdered cellulose, maize starch, pregelatinized starch and sodium starch glycolate was granulated with distilled water. After drying and milling (1000µm, 800rpm), granules were blended with magnesium stearate and compressed using a Modul™ P tablet press (tablet weight: 430 mg, main compression force: 12 kN). Single cell experiments using the ConsiGma™-25 system and ConsiGma™-1 system were performed in triplicate. Additionally, a 1h continuous run using the ConsiGma™-25 system was executed. Process outcomes (torque, barrel wall temperature, product temperature during drying) and granule (residual moisture content, particle size distribution, bulk and tapped density, hausner ratio, friability) as well as tablet (hardness, friability, disintegration time and dissolution) quality attributes were evaluated.

By performing a 1h continuous run, it was detected that a stabilization period was needed for torque and barrel wall temperature due to initial layering of the screws and the screw chamber walls with material. Consequently, slightly deviating granule and tablet quality attributes were obtained during the start-up phase of the 1h run. For the single cell runs, granule and tablet properties were comparable to results obtained during the second part of the 1h run (after start-up). Although deviating granule quality (particle size distribution and Hausner ratio) was observed due to the divergent design of the ConsiGma™-1 unit and the ConsiGma™-25 system (horizontal set-up) used in this study, tablet quality produced from

granules processed with the ConsiGma™-1 system was predictive for tablet quality obtained during continuous production using the ConsiGma™-25 system.

**KEYWORDS:** Continuous twin screw granulation and drying, Process scale-up, Repeatability, Granule and tablet quality, Formulation development and Process optimization

## INTRODUCTION

Continuous processing is well established in several industries (e.g. oil refining, food, chemicals). However, the production of pharmaceutical granules is still based on the batch concept. This is mainly related to the large profit margins within the pharmaceutical industry that allowed to accommodate inefficiencies of the drug manufacturing process, as manufacturing contributed for only a small part to the overall cost of a drug product. During the last decade, small drug pipelines, increased competition from generic companies, and shrinking health budgets have induced a mentality change that all pharmaceutical processes (including manufacturing) should run as efficient and cost-effective as possible [1].

It is generally known that scale-up of batch processes leads to high costs. Scale-up of a batch granulation process from lab-scale to production scale requires a whole range of granulators. This demands a large investment in hardware, but the main problem of this approach is that the formulation and the process are optimized using, in general, small scale equipment [2]. Subsequently, the formulation is 'frozen', i.e. during the clinical studies it is no longer possible to change the process and/or the formulation. For this reason, the formulation needs to be robust and has to result in the same quality of the product using small and large-scale equipment. However, during scale-up, the quality attributes of granules may change (e.g. particle size distribution, moisture content, friability, compressibility, compactibility) which may strongly influence the properties of the final tablet including dissolution rate of active substances. Scale-up problems are nowadays carefully analyzed by the registration authorities and in case of doubts about the quality of the production batch, expensive bioequivalence studies between small-scale and large-scale batches (i.e. manufactured with the small and large size equipment) have to be performed [3].

In contrast to the scale-up of a batch process where the dimensions of the equipment  $x$ ,  $y$ ,  $z$  are enlarged (with a development, optimization, and validation phase at each scale), an extension of process time on the same equipment using the same process settings can be performed for a continuous process [4, 5]. This provides enormous flexibility as production time, and not the size of the equipment, determines the total material output. Hence, according to the specific needs, a "Just-in-Time Production" of the desired amount of

material can be performed [6]. Furthermore, as the early clinical batches are produced on exactly the same equipment as the large production batches, no bioequivalence test between early clinical batches and later production batches is needed [7]. Therefore, it is believed that the shift to continuous manufacturing will result in significant cost savings and reduce the 'time to market' as process transfers from development to launch will be accelerated.

Our research group recently published a study on the stability and repeatability of three consecutive 5h production runs performed with a continuous 'from powder to tablet' manufacturing line, the ConsiGma<sup>TM</sup>-25 system introduced by GEA Pharma Systems (Wommelgem, Belgium). This system consists of a twin screw granulation unit directly coupled to a six-segmented fluid bed dryer (see section Materials and methods). It was concluded that, after start-up, granule and tablet quality attributes were constant in function of process time [8]. However, as during the early development phase, only a limited amount of drug substance is available and material costs are very high, small scale is key for successful introduction of continuous techniques in the pharmaceutical industry (i.e. to allow its use during formulation development and process optimization). Therefore, it is essential to determine if the product quality is similar when small quantities of materials are processed compared to the continuous processing of larger quantities.

The aim of the current study was to investigate if processing of materials in a single cell of the six-segmented dryer is predictive of full-scale manufacturing (i.e. when all drying cells are filled). Therefore, process outcomes (torque, barrel wall temperature, product temperature during drying) and granule (residual moisture content, particle size distribution, bulk and tapped density, Hausner ratio, friability) as well as tablet (hardness, friability, disintegration time and dissolution) quality attributes obtained during single cell runs and a 1h continuous run were compared. Additionally, the same formulation was granulated and dried using the ConsiGma<sup>TM</sup>-1 system (a mobile unit designed for R&D environment, see section Materials and methods) in order to evaluate the predictability of processing materials with this laboratory system for full-scale manufacturing with the ConsiGma<sup>TM</sup>-25 system.

## MATERIALS AND METHODS

### Materials

The formulation consisted of two active ingredients, powdered cellulose, maize starch, pregelatinized starch and sodium starch glycolate. A high-dosed slightly soluble API was combined with a low-dosed freely soluble API. The  $d_{50}$  values of both APIs were lower than 100  $\mu\text{m}$ . Distilled water was used as granulation liquid. Magnesium stearate was applied as lubricant during tableting. All materials were delivered by Johnson&Johnson, Janssen-Cilag, Italy.

### Preparation of granules and tablets

Granulation and drying experiments were performed using the ConsiGma<sup>TM</sup>-25 unit (C25) and the ConsiGma<sup>TM</sup>-1 (C1) system (GEA Pharma Systems, Wommelgem, Belgium). The former consists of three modules, as already extensively described by Chablani et al. [9] and Fonteyne et al. [10]: a high-shear wet granulation module, a six-segmented fluid bed dryer module and a granule conditioning module.

The granulation module consists of a high-shear co-rotating twin screw granulator without die plate. The length-to-diameter ratio of the granulation unit is 20:1. The barrel of the continuous granulator can be divided into two segments: a feed segment, where powder enters the barrel and consisting of conveying elements to transport the material through the barrel; and a work segment, where the powder is intensively mixed with the granulation liquid by kneading elements [10, 11]. To evaluate the granulation process, the torque on the screws and the temperature of the barrel wall at the work segment of the granulator were recorded (1 s interval). These parameters give an indication of the shear and compaction forces experienced by the materials inside the barrel. The equipment had an in-built torque gauge. At the work segment, the temperature of the barrel wall was monitored by a Pt100 temperature sensor. The jacket temperature was set at 25°C for the full length of the barrel. The screw speed was set at 900rpm. The screw configuration was composed of 2 kneading zones each consisting of 4 kneading elements ( $L=D/4$  for each kneading element) at an angle of 60 degrees [8]. Both kneading zones were separated by a conveying element ( $L=1.5D$ ). An extra conveying element ( $L=1.5D$ ) was implemented after the second kneading block

together with 2 narrow kneading elements ( $L=D/6$  for each kneading element) in order to reduce the amount of oversized agglomerates, as reported by Van Melkebeke et al. [12]. During processing, a powder premix of two active ingredients, powdered cellulose, maize starch, pregelatinized starch and sodium starch glycolate was gravimetrically dosed at a feed rate of 20 kg/h by a twin screw feeder (KT20, K-Tron Soder, Niederlenz, Switzerland). Distilled water as granulation liquid was pumped into the screw chamber using two peristaltic pumps (Watson Marlow, Cornwall, UK) and silicon tubings (internal and external diameter of 1.6 and 6.4 mm, respectively) connected to 1.6 mm nozzles. Liquid was introduced in the barrel in front of the first kneading element. The water concentration of the formulation during granulation was 13% (w/w), calculated on wet mass.

In the C25 system, the granulation unit is directly connected to a six-segmented fluid bed dryer. The segmented dryer was already presented in the introduction of this thesis. The filling time per cell was 180 seconds, resulting in a cell load of 1 kg granules (based on dry mass) at 20 kg/h powder feed rate. The inlet air temperature, humidity and airflow rate were set at 45°C, 10% and 420 m<sup>3</sup>/h, respectively. The drying time was fixed at 820 seconds. Inside each of the six dryer cells, a Pt100 temperature sensor monitored the product temperature. At the end of the drying cycle, a rotating discharge valve allowed the respective dryer cell to be vacuum discharged.

After drying, the dry granules were pneumatically transported to the granule conditioning unit. In this unit, each package of dried granules was collected separately. Samples of granules were taken for off-line analysis (loss on drying and particle size distribution). Thereafter, the remainder of the granules was milled at 800 rpm through a Quadro comil U10 (Quadro Engineering, Ontario, Canada), equipped with a 1000 µm grater screen. Milled granules were collected for subsequent analysis of quality attributes (particle size distribution, bulk and tapped density, Hausner ratio and friability).

After performing a 1h continuous run whereby full-scale loading of the dryer unit was achieved, short single cell runs (3 min per run) were done where only one segment of the six-segmented dryer was filled. Single cell runs were performed in triplicate (C25/1, C25/2 and C25/3) in order to test the repeatability of the system during formulation development and process optimization.

Milled granules collected at the beginning (after 3 min), the middle (after 30 min) and the end (after 60 min) of the 1h continuous run and milled granules from a single cell run (C25/2) were off-line blended with 0.58% (w/w) magnesium stearate before tableting. Tablets were manufactured at a compression force of 12 kN per tablet using a MODUL™ P tablet press (GEA Pharma Systems, Courtoy™, Halle, Belgium), equipped with oblong shaped concave Euro B punches (15.5 mm x 6.3 mm). Hardness, friability, disintegration time and dissolution profiles of the tablets were determined.

Moreover, experiments using the ConsiGma™-1 system (C1), a mobile laboratory unit, were performed in order to compare product quality from materials processed with C1 and C25. The ConsiGma™-1 system consists of a high-shear twin screw granulation module and a single cell fluid bed dryer (Fig. 1). As the granulation unit of the C1 system is identically to the C25 system, granulation parameters were directly transferred from C25 to C1. The dryer module of the C1 system consists of one dryer cell having the same design of a segment of the six-segmented fluid bed dryer of the C25 system. Also for the drying process of the C1, the same settings for air inlet temperature and drying time from the C25 drying process were applied. In order to have adequate fluidization of the wet granules inside the dryer cell of the C1, the air flow was set at 80 m<sup>3</sup>/h. Experiments were performed in triplicate (C1/1, C1/2 and C1/3) in order to test the repeatability of the system. Samples of dried granules were taken for off-line analysis (loss on drying and particle size distribution). Thereafter, the remainder of the granules was milled at 800 rpm through a Quadro comil U10 (Quadro Engineering, Ontario, Canada), equipped with a 1000 µm grater screen. Milled granules were collected for subsequent analysis of quality attributes (particle size distribution, bulk and tapped density, Hausner ratio and friability). Milled granules from test C1/2 were off-line blended with 0.58% (w/w) magnesium stearate and tableted as described above.





Figure 1: ConsiGma™-1 mobile laboratory unit: 1. Twin screw granulation module, 2. Fluid bed dryer module (1 segment).

## Evaluation of granules

### *Loss on Drying (LOD)*

Immediately after collection, the residual moisture content of the unmilled granules was determined via loss on drying (LOD) using a Mettler LP16 moisture analyser, including an infrared dryer and a Mettler PM460 balance (Mettler-Toledo, Zaventem, Belgium). A sample of approximately 9 g was dried at 105°C until the rate of change was less than 0.1% LOD for 30 seconds and the % LOD was then recorded. All LOD measurements were performed in triplicate.

### *Particle size analysis*

Sieve analysis was performed using a Retsch VE 1000 sieve shaker (Haan, Germany). Granules were placed on the shaker during 5 min at an amplitude of 2 mm using a series of sieves (75, 125, 250, 500, 1000, 1400, 2000 and 3150 µm). The amount of granules retained on each sieve was determined. All granule batches were measured in triplicate.

### *Flowability*

The bulk volume (V<sub>0</sub>) of 30 g milled granules was recorded in a 100 ml measuring cylinder as well as the volume after 1250 taps (V<sub>1250</sub>) in a tapping machine (J. Englesman, Ludwigshafen, Germany) (n=3). Bulk and tapped densities were calculated as 30 g / V<sub>0</sub> and 30 g / V<sub>1250</sub>, respectively. The Hausner ratio (HR) was calculated from the bulk and tapped density using the following equation,

$$\text{Hausner Ratio (HR)} = \rho_f / \rho_i$$

where  $\rho_i$  is the bulk density and  $\rho_f$  is the tapped density [13]. Flow properties were classified accordingly to the range of Hausner ratio values described in USP Powder flow <1174> [14].

### *Friability of granules*

The friability of milled granules was determined (n=3) using a friabilator (PTF E Pharma Test, Hainburg, Germany) at a speed of 25 rpm for 10 min, by subjecting 10 g (lwt) of milled granules together with 200 glass beads (mean diameter 4 mm) to falling shocks. Prior to determination, the granule fraction <250 $\mu$ m was removed to assure the same starting conditions. Afterwards, the glass beads were removed and the weight retained on a 250  $\mu$ m sieve (Fwt) was determined. The friability was calculated as  $((lwt - Fwt) / lwt) * 100$ .

## **Tablet evaluation**

### *Hardness*

The hardness of tablets (n=10) was determined (Sotax HT 10, Basel, Switzerland) after a storage period of at least 24 h at 21 °C and 30% RH.

### *Friability*

The tablet friability was determined (n=3) using a friabilator described in Eur. Ph. 5.0. (PTF E Pharma Test, Hainburg, Germany), at a speed of 25 rpm for 4 min. The percentage weight loss was expressed as the tablet friability.

### *Disintegration time and dissolution*

The disintegration time was determined (n=6) using the apparatus described in Eur. Ph. 5.0. (PTZ-E Pharma Test, Hainburg, Germany). Tests were performed in distilled water at  $37 \pm 0.5$  °C using disks. Dissolution tests were performed (n=3) in 900 ml 0.1N HCl (pH = 1) using the paddle method (VK 7010, Vankel, Cary, NC, USA). The temperature of the dissolution medium was maintained at  $37 \pm 0.5$ °C, while the rotation speed was set at 50 rpm. A 5 ml sample was withdrawn at 5, 10, 15, 20 and 30 min after starting the dissolution. The content of both drug components was determined via HPLC analysis.

### *HPLC analysis*

API concentrations were determined by a validated reversed phase high-performance liquid chromatography (HPLC)–UV method with gradient. The HPLC equipment used for analysis was a Waters 2695 Separations Module Alliance system. The Separations Module is an integrated solvent and sample management platform (quaternary solvent, high-performance solvent delivery system). A PDA detector ( $\lambda = 215$  nm) (Waters 2996 PDA Detector) was connected to the Alliance system and a Supelcosil LC-8-DB column (150 mm x 4.6 mm, 5  $\mu$ m) was used as the silica gel carrier with reversed phase properties. This sorbent was packed into a LiChroCart® 125-4 HPLC cartridge (Merck KGaA, Darmstadt, Germany).

## **RESULTS AND DISCUSSION**

### **Rationale of study design**

The aim of the current study was to investigate if processing of materials in a single cell of the six-segmented dryer of the C25 system is repeatable and predictive of full-scale manufacturing (i.e. when all drying cells are filled). Therefore, a 1h continuous run as well as three short single cell runs were performed. Vercruysse et al. [8] described that during start-up of a twin screw granulation process an increasing trend of torque can be expected due to initial layering of the granulator screws and the screw chamber walls (which could affect granule quality). To the opinion of the authors, during formulation development and process optimization, researchers prefer to evaluate several formulation and process conditions during short runs without in-between cleaning of the equipment. Based on this, screw

chamber walls and screws were not cleaned in-between the 1h run and the single cell runs. So, for the single cell runs (C25 as well as C1 experiments) the initial layering was already accomplished at the start of each run.

### **Evaluation of granulation and drying processes**

To evaluate the granulation process, torque and barrel wall temperature values were monitored for each run. Fig. 2a and 2b represent the evolution of torque and barrel wall temperature, respectively, during the 1h continuous run. An increasing trend of both parameters was observed in function of process time, in agreement to Vercruysse et al [8]. During processing, the granulator screws and the wall of the screw chamber were gradually layered with wet mass which increased friction inside the granulation unit. More friction resulted in higher torque values and barrel wall temperature. However, the rate of torque increase was not constant and dropped in function of process time: from a 1.5 Nm increase over the first 20 min of the run to a 0.5 Nm increase over the last 30 min of the run. In contrast to the ConsiGma<sup>TM</sup>-25 (C25) unit used by Vercruysse et al. [8], the system used in the current study did not have a feedback control mechanism in order to maintain a constant temperature of the barrel wall. In this way, an increase of the barrel wall temperature was observed due to the change in friction and torque. Consequently, for both torque and barrel wall temperature a similar trend was detected in function of process time. As can be seen from Fig. 2b, the barrel temperature increased from 23.6 °C to 29.5 °C during the first 30 min of the run and from 29.5 °C to 30.0 °C during the second part of the run.

a

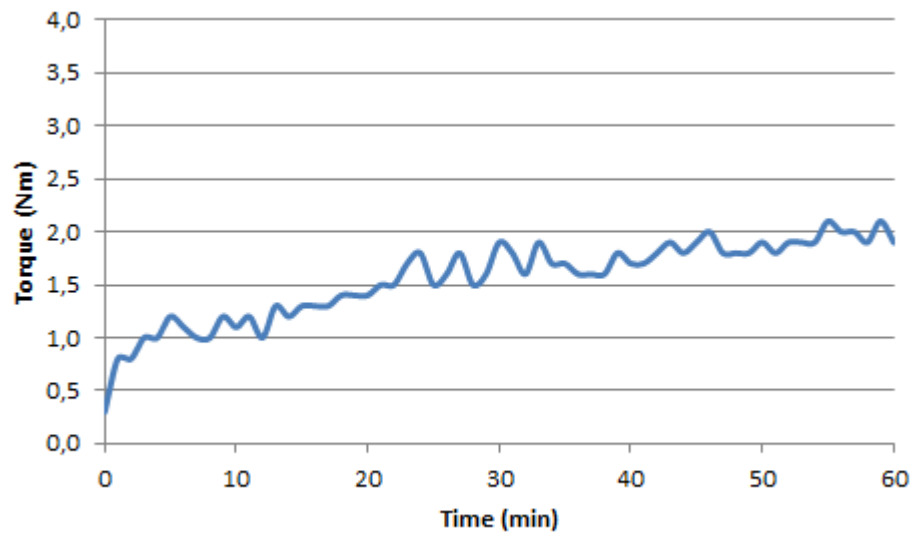

b

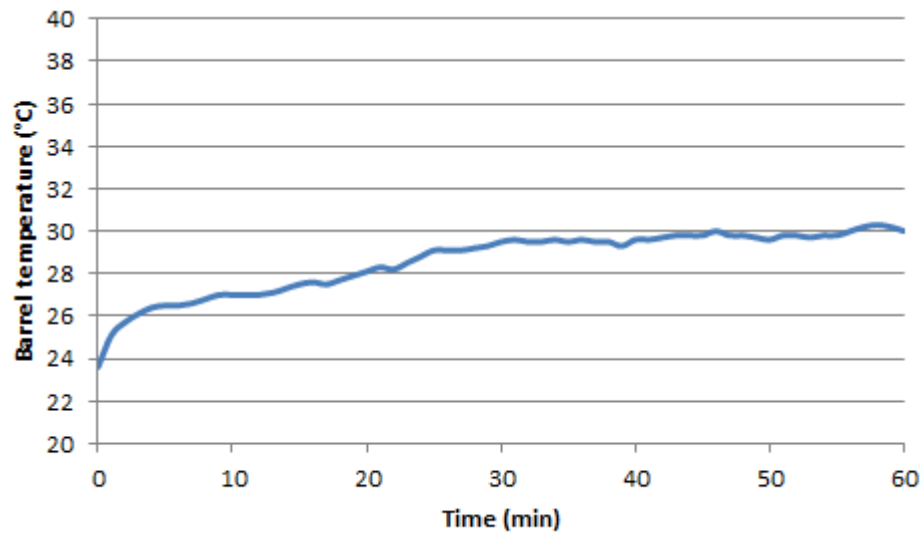

C

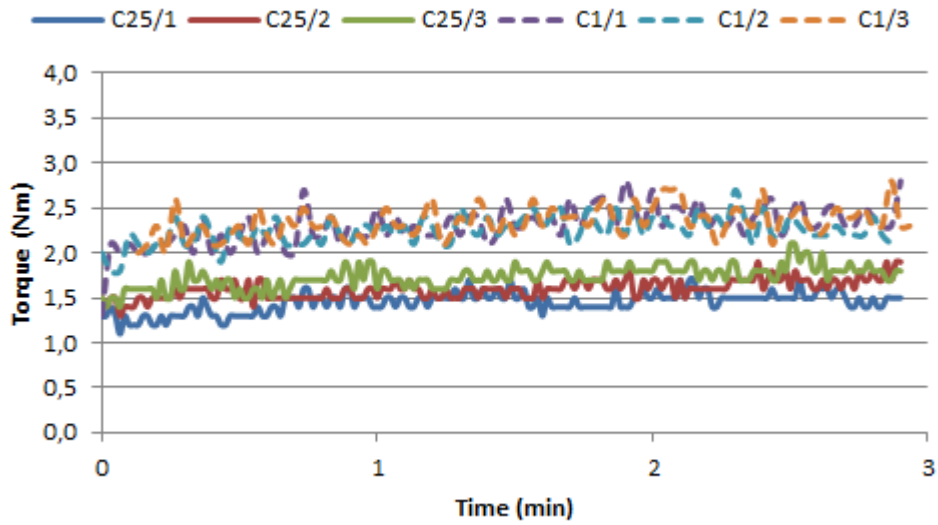

d

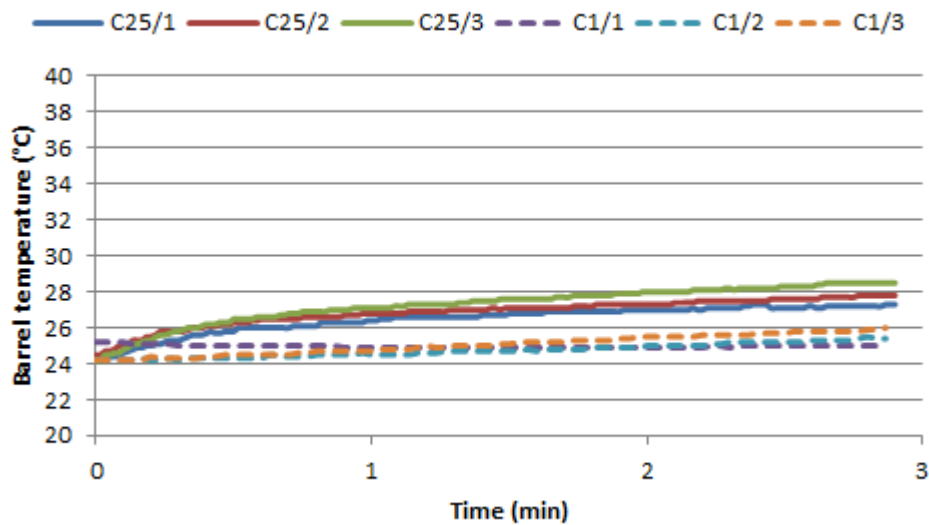

Figure 2: Evolution of critical process outcomes for the granulation module in function of process time: (a) torque and (b) barrel wall temperature of 1h run, and (c) torque and (d) barrel wall temperature of the single cell runs performed with the C25 (C25/1, C25/2 and C25/3) and the C1 (C1/1, C1/2 and C1/3) system.

After performing the 1h continuous run, short single cell runs were performed in triplicate. During each run (C25/1, C25/2 and C25/3), a single cell of the dryer was filled for 3 min in order to mimic short runs performed during formulation development and process optimization. Fig. 2c shows the torque profiles for the single cell runs. As no cleaning of the screws and screw chamber was carried out prior to and in-between the single cell runs, the layering, as described above, was already accomplished. So, only a limited increase of torque at the beginning of the run was seen. However, the barrel wall temperature increased 4°C over 3 min (Fig. 2d). As can be seen from Fig. 2c and d, process data trends were similar between the different runs, indicating high repeatability of the granulation process. For the experiments performed with the ConsiGma<sup>TM</sup>-1 (C1) laboratory system (C1/1, C1/2 and C1/3), also the torque directly reached a plateau phase as layering of the granulator screws and the barrel wall with wet mass was done before performing these runs, comparable to the short runs performed with the C25 system. However, for the C1 experiments, the barrel wall temperature did not show a similar trend as the torque. The barrel wall temperature was constant (Fig. 2d) during processing as this laboratory unit was equipped with a feedback control system. If the barrel wall temperature increased during processing, the temperature of the incoming water of the granulator jacket was decreased in order to maintain a constant temperature of the barrel wall.

After granulation, wet granules were directly transported to the dryer. As each cell of the six-segmented fluid bed dryer of the C25 system is equipped with a Pt100 temperature sensor, product temperature data were collected for all drying cells. Fig. 3 represents the temperature profiles for materials processed during the 1h continuous run (after 12, 30 and 48 min) together with the average temperature profiles of the single cell runs conducted with the C25 and the C1 system. Average temperature profiles were taken as process data between single cell runs were highly repeatable. From Fig. 3, it can be seen that the temperature profiles obtained during the 1h run and the C1 runs were comparable. However, granules processed during the single cell runs with the C25 system tended to dry slightly faster leading to a higher product temperature at discharge of the cell (37.8 °C compared to 35°C). This could be explained by the design of the C25 dryer. While the body of the C25 dryer is segmented into six identical dryer cells, only a single air stream enters the bottom of the dryer and is subsequently divided over the different segments. Hence, when

only one dryer cell is filled with granules, heat (i.e. energy) from the surrounding empty cells can be transferred by convection and conduction to the specific dryer cell filled with granules resulting in faster drying. In this way, a slightly higher product temperature at discharge of a single cell was obtained. During the 1h continuous run, convection and conduction was rather limited as surrounding cells were also filled with wet granules. For the C1 system, no heat convection/conduction phenomena took place as this system only consists of one drying cell and the wall of the drying cell is fabricated from polymethylmethacrylate compared to stainless steel for the C25 dryer.

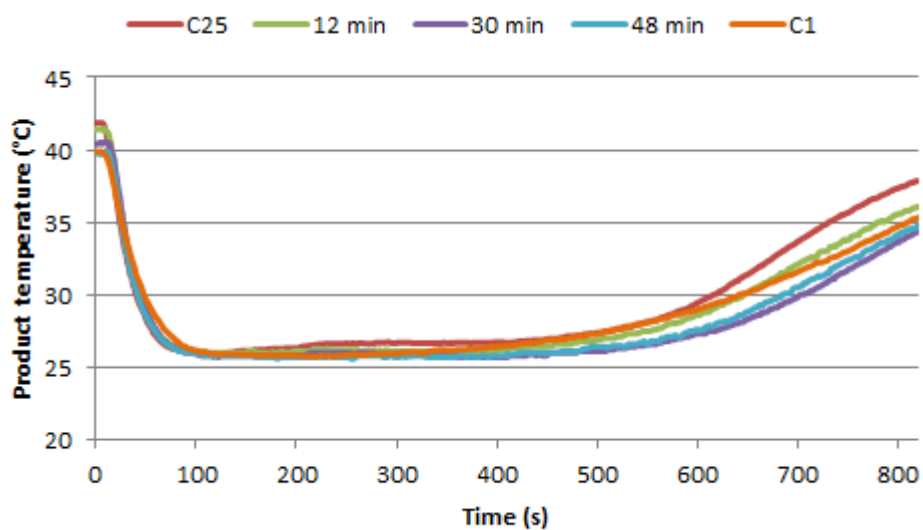

Figure 3: Evolution of product temperature in function of drying time. Temperature profiles for 1h run after 12, 30 and 48 min. and average temperature profiles for single cell runs C25 and C1.

### Evaluation of granule properties

After drying, unmilled granules were collected and immediately tested for loss on drying (LOD). For the 1h continuous run, no deviant LOD values during start-up or shutdown phase nor trends in function of process time were observed, indicating a stable and reliable drying process (Fig. 4). Furthermore, LOD values for granules from single cells were compared with LOD values obtained during the 1h run. Granules from single cells (C25) tended to have lower LOD values (1.40-1.57%) in comparison with granules collected during the 1h run (1.60-1.90%). This is in agreement with the observations made from the drying curves, as



discussed above (Fig. 3), and is linked to the difference in product temperature at discharge of a single cell compared to the 1h run. However, differences between the resulting LOD values were limited. Furthermore, LOD results for C1 experiments (1.74-1.97%) were similar to the LOD values obtained during the 1h run, as could be expected from the drying profiles (Fig. 3).

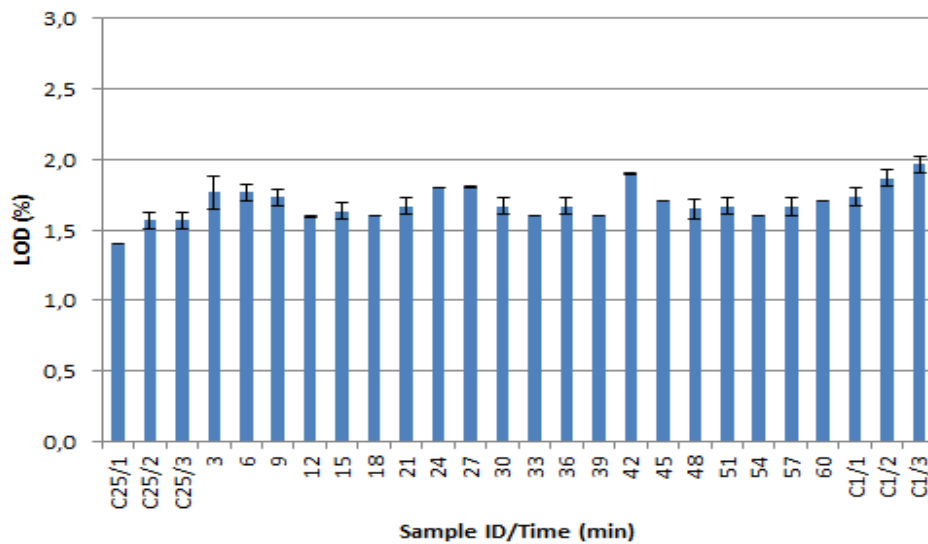
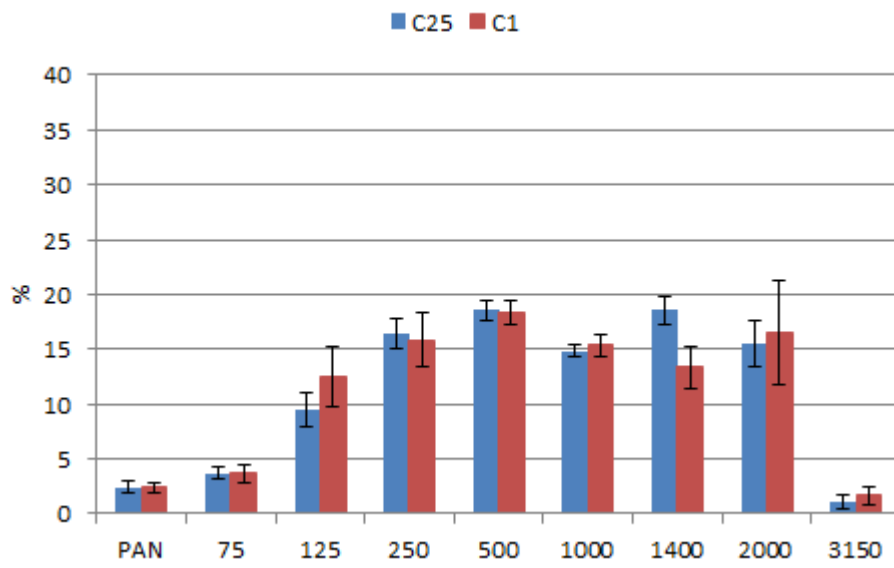

Figure 4: Loss on drying (LOD) results for granules derived from C1 (C1/1, C1/2 and C1/3) and C25 (C25/1, C25/2 and C25/3) single cell runs and 1h continuous run (per 3 min).

Fig. 5a represents the particle size distribution (PSD) results for granules collected at the outlet of the C25 and the C1 granulator and subsequently tray dried before sieve analysis. PSD results were highly repeatable between the different repetitions and were similar for both systems. This could be expected as the twin screw granulation units of the C25 and the C1 system are identical.

a



b

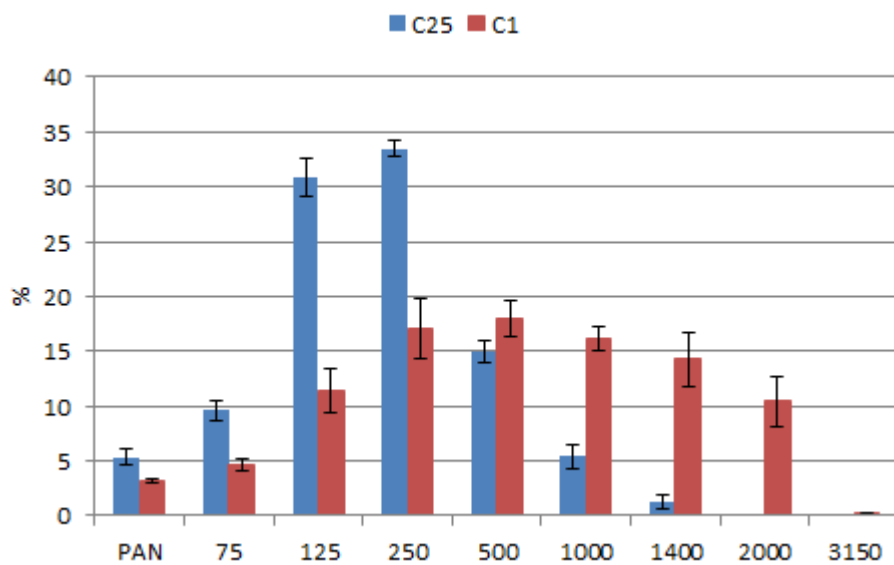
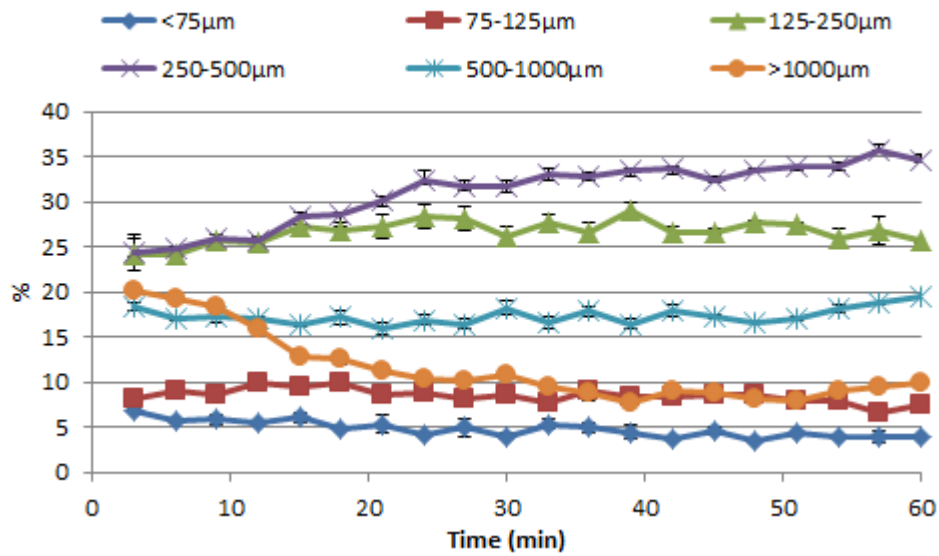

Figure 5: Results for particle size distribution of granules derived from C25 and C1 single cell runs after (a) tray drying and (b) fluid bed drying.

In order to test the impact of the fluid bed drying process on the PSD of the granules, PSD of unmilled fluid bed dried granules was determined. From Fig. 5b, it is clear that due to dynamic drying a shift of the PSD could be detected for the granules processed with the C25 system. The fraction of granules  $>1000\ \mu\text{m}$  decreased while the fraction  $<500\ \mu\text{m}$  increased, compared to tray dried granules (Fig. 5a). As water was used as granulation liquid and the residence time (limited to seconds) of material inside the granulator was too low to dissolve the pregelatinized starch, liquid bridges formed during wet granulation were weak and consequently granules were highly sensitive to attrition. Surprisingly, for the C1 experiments, no shift in PSD was observed after dynamic drying. In order to clarify this, design differences between both systems should be taken into account. For the C1 system, wet granules are transferred from the outlet of the granulator to the dryer by gravity. However, as the C25 system in this study had a horizontal set-up, wet granules were pneumatically transferred from the outlet of the granulator to the top of the six-segmented dryer. As a result, wet granules produced with the C25 system were more subjected to breakage during transfer through mutual collisions of granules and collisions between granules and the wall of the transfer line and the wall of the dryer during entry of the dryer.

PSD of unmilled granules derived from the 1h run are shown in Fig. 6a. Clear changes of PSD were observed during the first 30 min of the 1h run, in agreement to the trends observed for torque and barrel wall temperature (Fig. 2a and b). During start-up, the amount of granules between 250 and 500  $\mu\text{m}$  increased whereas the size fraction  $>1000\ \mu\text{m}$  decreased. It is suggested that during granulation larger agglomerates ( $>1000\ \mu\text{m}$ ) were more efficiently chopped during the second half of the 1h run as a result of the decreased free volume inside the barrel caused by the layering of the screws and screw chamber wall. PSD results of unmilled granules derived from C25 single cells were comparable to PSD of unmilled granules from the second half of the 1h run as during the single cell runs the layering of screws and screw chamber wall was already accomplished as described above (data not shown).

a



b

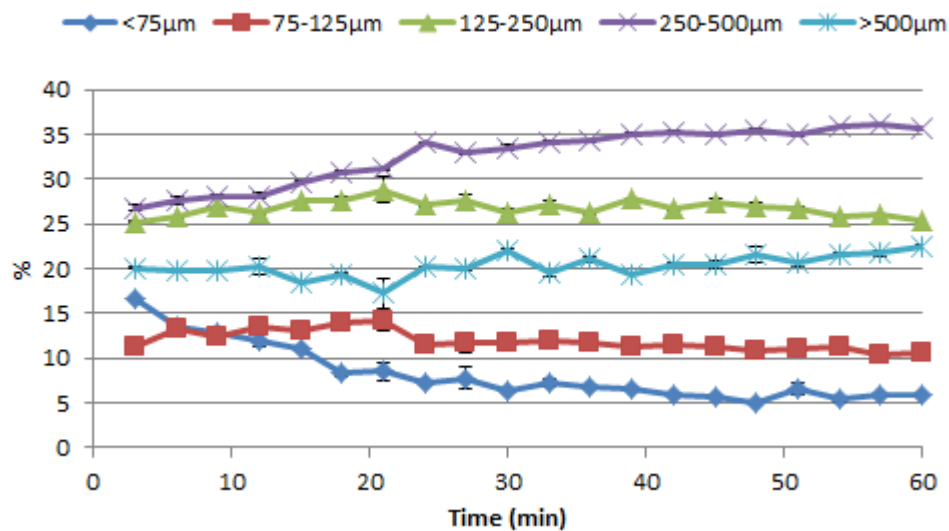

Figure 6: Evolution of particle size distribution of granules for 1h run in function of process time: (a) unmilled and (b) milled granules.

From the PSD results of milled granules derived from the 1h run (Fig. 6b), it is clear that milling of granules collected during the start-up phase of the run resulted in a higher amount of fines (<75 µm) compared to the second part of the run. This can be explained by the PSD results obtained for the unmilled granules (Fig. 6a). During start-up, more agglomerates

(>1000  $\mu\text{m}$ ) were formed which led to extra creation of fines by abrasion during milling. This is not in agreement with Vercruyssen et al. [8], where for the PSD of milled granules collected during the start-up phase a slightly lower amount of fines was detected compared to the steady-state phase. There, in contrast to the current study, the twin screw granulator was equipped with a feedback cooling system and deviant PSD results during the start-up phase were mainly related to the initial layering of the grater type mill screen.

PSD of milled granules derived from single cell runs for the C25 and C1 system and the 1h run (after 3 min, 30 min and 60 min) are shown in Fig. 7. PSD of milled granules produced during the first 3 min of the 1h run showed a higher amount of fines (<75  $\mu\text{m}$ ). However, PSD results from single cell experiments with the C25 system were predictive for the PSD of granules obtained after 30 min and 60 min. Obviously, PSD of milled granules derived from the C1 experiments deviated from those observed for the C25 system because of clear differences in PSD results of unmilled granules as discussed above.

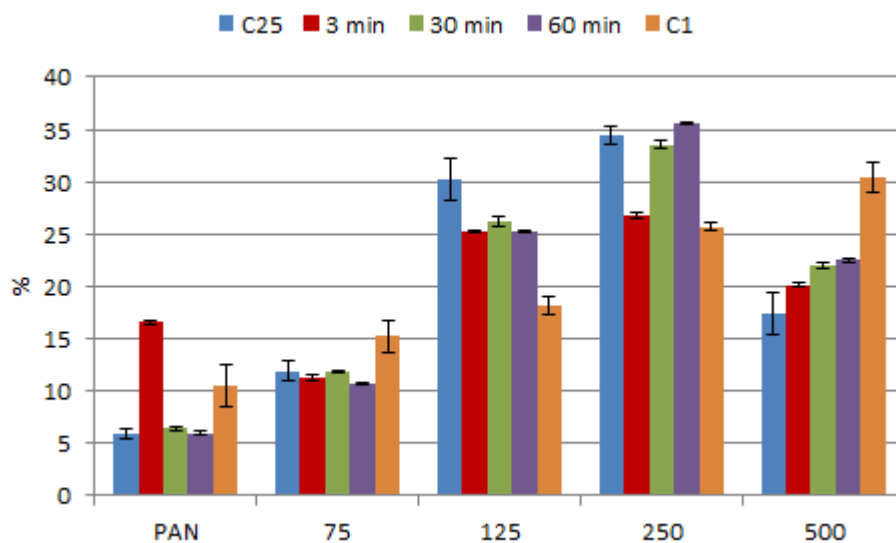

Figure 7: Particle size distribution of milled granules derived from C25 and C1 single cell runs and 1h run (after 3 min, 30 min and 60 min).

Hausner ratio was calculated from the bulk and tapped densities of milled granules to describe flow properties. The Hausner ratio decreased in function of process time during the first 30 min of the 1h run (from 1.26 to 1.17) (Fig. 8a). During the second part of the 1h run, the Hausner ratio was stable between 1.17 and 1.20, indicating fair flowing properties of the

granules. The higher amount of fines after milling, obtained during the start-up phase of the 1h run reduced the flow properties, as indicated by a higher Hausner ratio. Hausner ratio of granules from C25 single cell runs (1.17 to 1.19) was comparable to Hausner ratio of granules obtained during the second part of the 1h run (Fig. 8b). As the PSD of milled granules from the C1 experiments showed a higher amount of granules <125  $\mu\text{m}$ , the Hausner ratio was higher (1.25 to 1.27) compared to the C25 single cell runs.

For all granules, the friability, an estimate for granule strength, was low (< 26%). Due to the low friability, downstream processing problems were avoided. During the 1h run, the granule friability decreased in function of process time (from 25% to 15%) (Fig. 9). A lower torque and barrel temperature at the start-up of the process resulted in more friable granules. It is expected that, in function of process time, next to the barrel wall temperature also the product temperature (even more) increased. In this way, more powder compounds dissolved in the granulation liquid, which formed solid bridges after recrystallization during drying. Furthermore, as the free volume decreased by layering of the screws and the walls of the screw chamber, it is suggested that the compaction forces inside the twin screw granulator increased in function of process time. Granules from the C25 (16% to 18%) as well as from the C1 single cell runs (17% to 19%) showed comparable results to granules obtained during the second part of the 1h run.

a

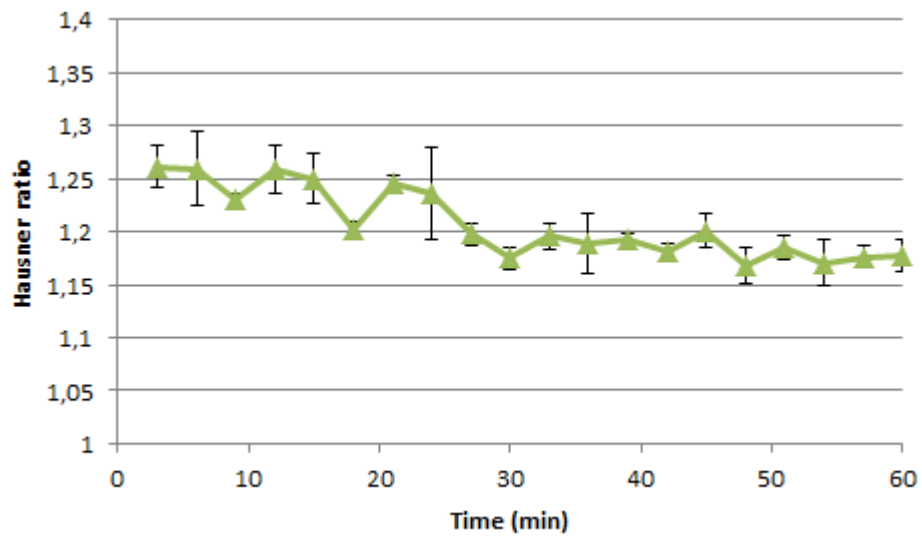

b

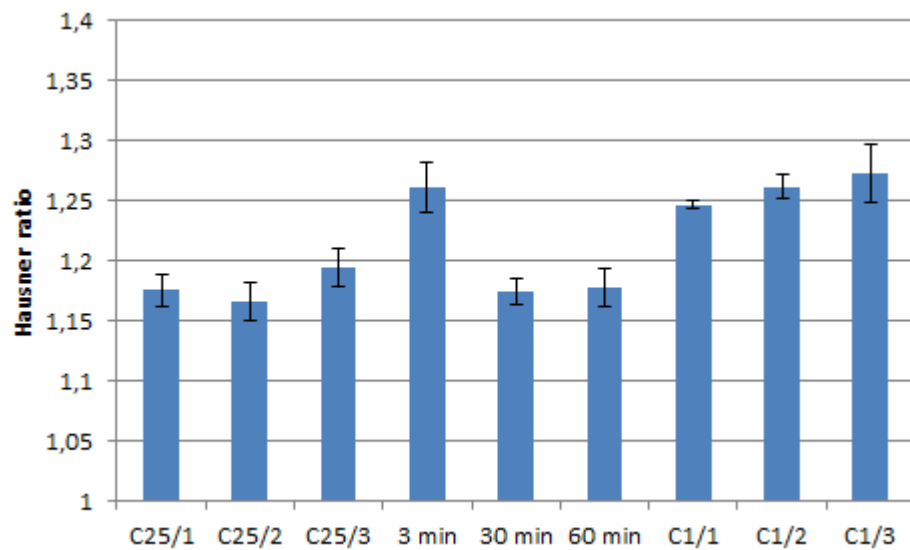

Figure 8: Hausner ratio of milled granules: (a) evolution in function of process time for the 1h run and (b) comparison between C25 (C25/1, C25/2 and C25/3) and C1 (C1/1, C1/2 and C1/3) single cell runs and 1h run (after 3 min, 30 min and 60 min).

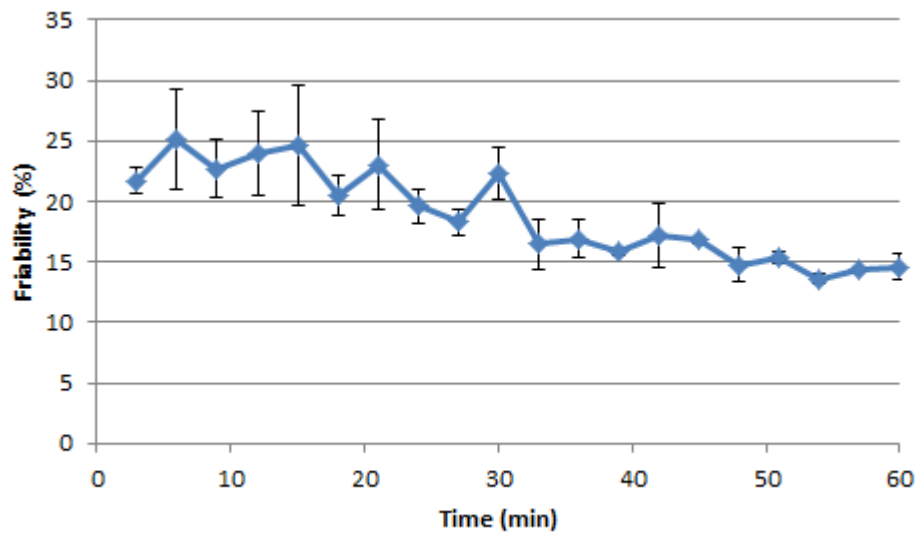

Figure 9: Evolution of friability of milled granules in function of process time.

### Evaluation of tablet properties

Based on the results for the evaluation of the granule properties, it is clear that for the 1h continuous run trends were observed in function of process time. Furthermore, granule properties of the C25 single cell runs showed good predictability to quality of granules obtained during the second part of the 1h run. In order to investigate the influence of deviant granule properties on the tablet properties, milled granules of a single cell run performed with the C25 (C25/2) and the C1 (C1/2) system as well as granules obtained after 3 min, 30 min and 60 min during the 1h continuous run were withheld for tableting trials.

Hardness values for all tablets were not significantly different (100-113 N), although tablets made from granules collected at the beginning of the 1h run (after 3 min) tended to have a lower hardness (Fig. 10). As described above, granules collected at the beginning of the 1h run showed a higher friability indicating the presence of a lower amount of solid bridges. This could explain the lower hardness values obtained for the resulting tablets.

Friability of all tablets was low (0.10 – 0.13 %), indicating good resistance to abrasion for handling, coating, shipment and storage of the tablets. Friability of tablets produced from granules collected during the C25 (0.12 %) and C1 (0.12 %) single cell runs were comparable to friability of tablets derived from the 1h run (0.13 %, 0.10 % and 0.11 % after 3 min, 30 min and 60 min, respectively).



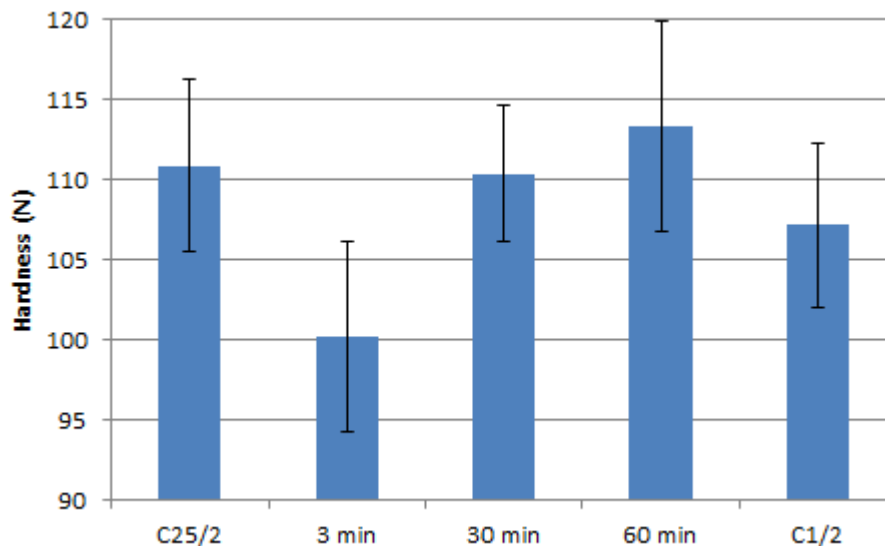

Figure 10: Hardness of tablets produced from granules collected during single cell runs (C25/2 and C1/2) and after 3 min, 30 min and 60 min during the 1h run.

Lower hardness values obtained for tablets produced from granules collected at the beginning of the 1h run (after 3 min) resulted in faster disintegration ( $96 \pm 27$  s), compared to tablets from a C25 and C1 single cell run ( $146 \pm 14$  s and  $136 \pm 14$  s, respectively) and after 30 min ( $177 \pm 31$  s) and 60 min ( $189 \pm 32$  s) during the 1h run.

Fig. 11 shows the dissolution profiles from the produced tablets. As the same conclusions could be taken from the release profiles of both drug substances, the results for only one drug substance were represented in Fig. 11. Furthermore, as this study was performed with an immediate release formulation, all tablets showed fast release ( $> 90\%$  after 10 min). Differences between release profiles were only detected after 5 min dissolution time. Due to the shorter disintegration time, tablets manufactured from granules collected at the beginning of the 1h run showed higher release after 5 min. After 5 min, 95.5 % the drug substance was released compared to 81.7 % and 86.2 % for tablets of C25 and C1 single cell runs, respectively. Dissolution profiles of tablets derived from single cell runs were predictive of the release properties of tablets during the second part of the 1h run.

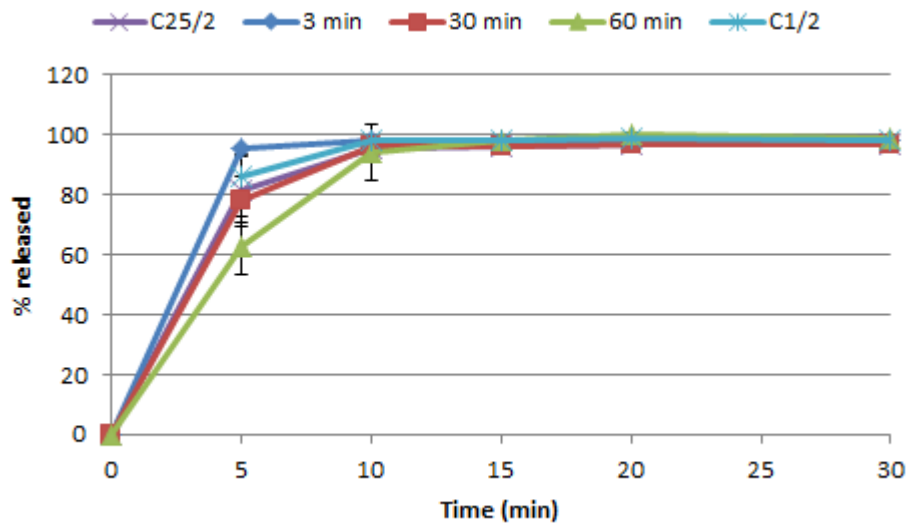

Figure 11: Dissolution profiles of tablets produced from granules collected during single cell runs (C25/2 and C1/2) and after 3 min, 30 min and 60 min during the 1h run.

## Conclusions

In this research paper, process data and quality attributes of granules and tablets obtained during a 1h continuous run and short single cell runs using the ConsiGma<sup>TM</sup>-25 system were described and discussed. By performing a 1h continuous run, it was detected that a stabilization period was needed for the torque and the temperature of the barrel wall due to initial layering of the screws and the screw chamber walls with material. Consequently, slightly deviating granule and tablet quality attributes were obtained during the first 30 min of the 1h run. However, as for the single cell runs the initial layering was already accomplished in advance, granule and tablet properties were comparable to results obtained during the second half of the 1h run. No deviating granule and tablet quality was observed during the shutdown phase of the continuous run. Hence, this study showed that processing of material in a single cell of the segmented dryer unit of the ConsiGma<sup>TM</sup>-25 system was repeatable and that the quality attributes of granules (residual moisture content, particle size distribution, bulk and tapped density, hausner ratio, friability) and tablets (hardness, friability, disintegration time and dissolution) processed in a single cell were predictive for the steady state phase during full-scale manufacturing.

Furthermore, the predictability of processing materials using the ConsiGma™-1 system for full-scale manufacturing with the ConsiGma™-25 system was investigated. Although deviating granule quality (particle size distribution and Hausner ratio) was observed due to the divergent design of the ConsiGma™-1 (vertical set-up) and the ConsiGma™-25 system (horizontal set-up) used in this study, tablet quality obtained from granules processed with the ConsiGma™-1 system was predictive for tablet quality obtained during continuous production using the ConsiGma™-25 system.

#### **ACKNOWLEDGEMENTS**

The authors would like to thank Dr. Tom Van Den Kerkhof and Mr. Stijn Hendrickx for their contribution to the HPLC analysis.

## REFERENCES

- [1] C. Vervaet, J. Vercruyse, J.P. Remon, T. De Beer, Continuous Processing of Pharmaceuticals, in: J. Swarbrick (Ed.) Encyclopedia of Pharmaceutical Science and Technology, Fourth Edition, Taylor and Francis, New York (USA), Published online: 23 Aug 2013; 644-655.
- [2] C. Vervaet, J.P. Remon, Continuous granulation in the pharmaceutical industry, Chemical Engineering Science 60 (2005) 3949-3957.
- [3] H. Leuenberger, New trends in the production of pharmaceutical granules: the classical batch concept and the problem of scale-up, European Journal of Pharmaceutics and Biopharmaceutics 52 (2001) 279-288.
- [4] G. Betz, P. Junker-Burgin, H. Leuenberger, Batch and continuous processing in the production of pharmaceutical granules, Pharmaceutical Development and Technology 8 (2003) 289-297.
- [5] H. Leuenberger, New trends in the production of pharmaceutical granules: batch versus continuous processing, European Journal of Pharmaceutics and Biopharmaceutics 52 (2001) 289-296.
- [6] C. Vervaet, J.P. Remon, Continuous Granulation, in: D.M. Parikh (Ed.) Handbook of Pharmaceutical Granulation Technology, Informa Healthcare, New York (USA), 2009, 308-322.
- [7] H. Leuenberger, Scale-up in the 4th dimension in the field of granulation and drying or how to avoid classical scale-up, Powder Technology 130 (2003) 225-230.
- [8] J. Vercruyse, U. Delaet, I. Van Assche, P. Cappuyns, F. Arata, G. Caporicci, T. De Beer, J.P. Remon, C. Vervaet, Stability and repeatability of a continuous twin screw granulation and drying system, European journal of pharmaceutics and biopharmaceutics 85 (2013) 1031-1038.

- [9] L. Chablani, M.K. Taylor, A. Mehrotra, P. Rameas, W.C. Stagner, Inline real-time near-infrared granule moisture measurements of a continuous granulation-drying-milling process, *AAPS Pharmscitech* 12 (2011) 1050-1055.
- [10] M. Fonteyne, J. Vercruysse, D.C. Díaz, D. Gildemyn, C. Vervaet, J.P. Remon, T.D. Beer, Real-time assessment of critical quality attributes of a continuous granulation process, *Pharmaceutical Development and Technology* 18 (2013) 85-97.
- [11] J. Vercruysse, D.C. Diaz, E. Peeters, M. Fonteyne, U. Delaet, I. Van Assche, T. De Beer, J.P. Remon, C. Vervaet, Continuous twin screw granulation: Influence of process variables on granule and tablet quality, *European Journal of Pharmaceutics and Biopharmaceutics* 82 (2012) 205-211.
- [12] B. Van Melkebeke, C. Vervaet, J.P. Remon, Validation of a continuous granulation process using a twin-screw extruder, *International Journal of Pharmaceutics* 356 (2008) 224-230.
- [13] H.H. Hausner, Friction conditions in a mass of metal powder, *International journal of Powder Metallurgy* 3 (1967) 7-13.
- [14] P.f. General Test <1147>, in: *USP32/NF27*, U.S. Pharmacopeial Convention, Rockville, MD, 2009, 688-691.



# 5

## **STABILITY AND REPEATABILITY OF A CONTINUOUS TWIN SCREW GRANULATION AND DRYING SYSTEM**

Parts of this chapter are published in:

J. Vercruyse, U. Delaet, I. Van Assche, P. Cappuyns, F. Arata, G. Caporicci, T. De Beer, J.P. Remon, C. Vervaet, Stability and repeatability of a continuous twin screw granulation and drying system, *European Journal of Pharmaceutics and Biopharmaceutics* 85 (2013) 1031-1038.

**Abstract**

The aim of this study was to investigate the process transfer of a commercially available product from the current batch fluid bed granulation and drying production method to an innovative continuously operating 'from powder to tablet' production line using twin screw granulation as an intermediate granulation step. By monitoring process outcomes (torque, water temperature at the granulator jacket inlet, differential pressure over the dryer filters, temperature mill screen) and granule and tablet quality in function of process time, the stability and repeatability during long production runs were determined.

Three consecutive 5h 'from powder to tablet' production runs were performed using the ConsiGma<sup>TM</sup>-25 system (GEA Pharma Systems, Wommelgem, Belgium). A premix of two active ingredients, powdered cellulose, maize starch, pregelatinized starch and sodium starch glycolate was granulated with distilled water. After drying and milling (1000 $\mu$ m, 800rpm), granules were in-line blended with magnesium stearate and directly compressed using a Modul<sup>TM</sup> P tablet press (tablet weight: 430 mg, main compression force: 12 kN). Granule (loss on drying, particle size distribution, friability, flow) and tablet (weight uniformity, hardness, thickness, friability, content uniformity, disintegration time and dissolution) quality was evaluated in function of process time.

For each of the logged process outcomes, a stabilization period was needed to reach steady-state conditions. Slightly deviating particle size distribution and friability results for milled granules were observed during start-up due to initial layering of the mill screen. However, no deviating tablet quality was detected in function of process time.

For multiple hours, granule and tablet quality was constant in function of process time. Furthermore, process data trends were highly repeatable. Consequently, the ConsiGma<sup>TM</sup>-25 system can be considered as a stable and repeatable system for the continuous production of tablets via wet granulation.

**KEYWORDS:** Continuous twin screw granulation and drying, Process transfer, Stability, Repeatability, Granule and tablet quality



## INTRODUCTION

Whereas most pharmaceutical manufacturing processes are currently run via a series of batch-wise unit-operations, continuous processing offers several advantages to improve the manufacturing efficiency of solid dosage forms. Continuous production leads to reduced costs through faster development and less scale-up, smaller equipment footprint and elimination of intermediate storage. Furthermore, online monitoring and real-time testing results in improved product quality.

However, despite several advantages related to continuous production, the pharmaceutical industry has been slow to adopt the principle of continuous processing. On the one hand, high investment costs are required for the installation of new manufacturing equipment allowing continuous production. On the other hand, limited material volumes typical for the pharmaceutical industry would lead to frequent product changeovers on the continuous line. Additionally, pharmaceutical companies fear delay of product approval by the regulatory authorities. Due to high profit margins on their products, until recently, the economical need to change the manufacturing concept of pharmaceuticals was low. Currently, however, also the pharmaceutical industry is forced to improve the cost efficiency of their production due to the competition with the generics [1-4].

Although specific types of continuous wet granulators have been on the market for years (e.g. horizontal fluid bed granulators, multistage fluid bed, spray drier with integrated fluid bed, instant granulators, plough-shear mixers), none of these have made a significant impact within the pharmaceutical industry. On the one hand, this could be explained by the reluctance to move towards continuous processing (e.g. high profit margins, regulatory hurdles,...). On the other hand, equipment-related deficiencies were encountered as these techniques were only suitable for high material throughputs which are seldom required for pharmaceutical processing [3, 4]. However, equipment manufacturers have identified the specific needs for continuous wet granulation within the pharmaceutical industry and as a result a new generation of small and versatile continuous granulators has emerged, also suitable for manufacturing pharmaceuticals at a low production rate (10-50 kg/h).

To fully benefit from the advantages offered by continuous wet granulation, the new techniques should be applicable to new products but also to existing products. Hence, it

should be possible to continuously process formulations currently agglomerated using conventional batch-wise fluid bed or high-shear granulation into an end product having similar physico-chemical characteristics (hardness, friability, disintegration, dissolution,...). This would allow transferring existing production processes from a batch process using low or high shear granulators to the novel continuous wet granulator. Furthermore, appropriate continuous manufacturing techniques for solid dosage forms should allow conversion of powder into tablets in development, pilot, clinical and production volumes in a single compact unit and batch sizes should only be determined by the length of the run. Therefore, it is essential that the process continuously operates under steady state conditions to manufacture granules and tablets of a specific quality for any length of time.

During the last decade, twin screw granulation as a continuous particle size enlargement technique has already been described by several research groups [5-10]. Keleb et al. [5] evaluated the continuity of the technique over a period of 8h. Recently, Dhenge et al. [9] published a study on the progression of granules in different compartments along the length of the screws in a twin screw granulator, helping to provide an understanding of the twin screw granulation process.

The aim of the current study was to investigate the process transfer of a commercially available product from the actual batch fluid bed granulation and drying production method to an innovative continuously operating tablet manufacturing line, the ConsiGma<sup>TM</sup>-system (GEA Pharma Systems, Wommelgem, Belgium). The wet granulation module of this system consists of a high-shear twin screw granulator. After initial optimization work, three consecutive 5h 'from powder to tablet' production runs were performed in order to investigate the stability and repeatability of this system. Therefore, granule and tablet quality attributes were determined in function of process time. Besides, quality attributes of granules and tablets produced by the actual batch process and the continuous system were compared.

## MATERIALS AND METHODS

### Materials

The formulation consisted of two active ingredients, powdered cellulose, maize starch, pregelatinized starch and sodium starch glycolate. A high-dosed slightly soluble API was combined with a low dosed freely soluble API. Both  $d_{50}$  values of the APIs were lower than 100  $\mu\text{m}$ . Distilled water was used as granulation liquid. Magnesium stearate was applied as lubricant during tableting. All materials were delivered by Johnson&Johnson, Janssen-Cilag, Italy.

### Preparation of granules and tablets

Granulation and drying experiments were performed using the ConsiGma<sup>TM</sup>-25 unit (GEA Pharma Systems, Wommelgem, Belgium) (Fig. 1). This system consists of three modules, as already described by Chablani et al. [11] and Fonteyne et al. [12]: a high-shear wet granulation module, a six-segmented fluid bed dryer module and a granule conditioning module.

The granulation module consists of a high-shear co-rotating twin screw granulator without die plate. The length-to-diameter ratio of the granulation unit is 20:1. The barrel of the continuous granulator can be divided into two segments: a feed segment, where powder enters the barrel and consisting of conveying elements to transport the material through the barrel; and a work segment, where the powder is intensively mixed with the granulation liquid by kneading elements [12, 13]. At the work segment, the temperature of the barrel wall was controlled by a Pt100 temperature sensor. As the barrel jacket was not divided into different temperature zones, the full length of the barrel was preheated to equal temperature (25°C).



Figure 1: Consigma™-25 continuous tablet manufacturing line: 1. Powder dispensing, 2. Screw-based wet granulation module, 3. Segmented fluid bed dryer, 4. Granule conditioning unit with 5. Quadro® comil® and 6. Blender (external phase), 7. Blender (lubricant), 8. Modul™ P tablet press.

To evaluate the stability of the granulation process, the torque on the screws and the temperature of the water at the granulator jacket inlet (1 s interval) were recorded. The latter was monitored as changes of the temperature of the barrel wall at the work segment caused by friction were controlled by adapting the temperature of the water inside the granulator jacket (feedback control system). Both torque and water temperature at the granulator jacket inlet give an indication of the shear and compaction forces experienced by the materials inside the barrel. The equipment had an in-built torque gauge. The screw speed was set at 900rpm. The screw configuration was composed of 2 kneading zones each consisting of 4 kneading elements ( $L=D/4$  for each kneading element) at an angle of 60 degrees (Fig. 2). Both kneading zones were separated by a conveying element ( $L=1.5D$ ). An extra conveying element ( $L=1.5D$ ) was implemented after the second kneading block together with 2 narrow kneading elements ( $L=D/6$  for each kneading element) in order to reduce the amount of oversized agglomerates, as reported by Van Melkebeke et al. [7]. During processing, a powder premix of two active ingredients, powdered cellulose, maize starch, pregelatinized starch and sodium starch glycolate was gravimetrically dosed at a feed

rate of 20 kg/h by a twin screw feeder (KT20, K-Tron Soder, Niederlenz, Switzerland). Distilled water as granulation liquid was gravimetrically pumped into the screw chamber using two peristaltic pumps (Watson Marlow, Comwall, UK) and silicon tubings (internal and external diameter of 1.6 and 6.4 mm, respectively) connected to 1.6 mm nozzles. Liquid was added in front of the first kneading element. The water concentration was equal to 13% (w/w), calculated on wet mass.



Figure 2: Detail of last part of twin screws.

In the ConsiGma™-25 unit, the granulation unit is directly connected to a six-segmented fluid bed dryer, either horizontally or vertically. As the granulation and drying unit of the ConsiGma™-25 unit used in this study were lined up vertically, the wet granules were gravimetrically transported to the top of the six-segmented fluid bed dryer (six identical dryer cells) through a rotating inlet valve. The filling time per cell was 180 seconds, resulting in a cell load of 1 kg granules (based on dry mass) at 20 kg/h powder feed rate. The inlet air temperature, humidity and airflow rate were set at 45°C, 10% and 420 m<sup>3</sup>/h, respectively. The drying time was fixed at 790 seconds. At the end of the drying cycle, a rotating discharge valve allowed the respective dryer cell to be vacuum discharged followed by one blow back in order to clear the corresponding filter. During production, the differential pressure over the dryer filters was monitored as an indication for the filter loading.

After drying, the dry granules were pneumatically transported to the granule conditioning unit. In this unit, each package of dry granules was milled through a Quadro comil U10 (Quadro Engineering, Ontario, Canada), equipped with a 1000µm grater screen rotating at 800rpm. The temperature of the mill screen was monitored by a Pt100 temperature sensor. After milling, materials were pneumatically transported to an in-line conical ribbon blender and blended with 0.58% (w/w) magnesium stearate (60rpm for 1 min). The final blend was gravimetrically transported to the hopper of a MODUL™ P tablet press (GEA Pharma

Systems, Courtoy<sup>TM</sup>, Halle, Belgium). The tablet press was equipped with oblong shaped concave Euro B punches (15.5 mm x 6.3 mm). Tablets (430 mg) were manufactured at a compression force of 12 kN per tablet.

For all runs, milled granules and tablets were sampled every 30 minutes. Furthermore, the first filling cycle of the dryer (6 cells) and the last filling cycle of the dryer (6 cells) were collected as milled granules and tablets for run 1 and run 2, respectively. Samples of milled granules were taken by disconnecting the vacuum transfer line between the granule conditioning unit and the in-line lubricant blender at predefined time points. Loss on drying (LOD), particle size distribution (PSD), friability, bulk and tapped density and Hausner ratio were determined for the milled granules. Weight uniformity, hardness, thickness, friability, content uniformity, disintegration time, and dissolution of the tablets were tested. Quality attributes of granules and tablets produced by the continuous system were compared with granule and tablet quality data derived from three batches of the actual batch process (Table 1).

For the continuous process, 100 kg of dry powder blend was processed into tablets during 5h production time (i.e. 20 kg/h). Although the actual process time for the batch process was similar (about 12h for 240kg), the total time to manufacture the tablets via the batch process was much longer compared to the fully continuous from-powder-to-tablet process due to the lag time and off-line testing between the different unit operations of the batch process. Flow diagrams of both production methods are shown in Fig. 3.

Table 1: Overview of granule and tablet quality attributes derived from the conventional batch process: LOD (n=1), PSD (>500 $\mu$ m, 250 $\mu$ m-500 $\mu$ m, 125 $\mu$ m-250 $\mu$ m, 75 $\mu$ m-125 $\mu$ m and <75 $\mu$ m) (n=3, mean  $\pm$  SD), bulk density (n=3, mean  $\pm$  SD), tapped density (n=3, mean  $\pm$  SD) and Hausner ratio (n=3, mean  $\pm$  SD) for granules and weight (n=20, mean  $\pm$  SD), hardness (n=12, mean  $\pm$  SD), thickness (n=12, mean  $\pm$  SD), friability (n=8, mean  $\pm$  SD), disintegration time (n=8, mean  $\pm$  SD) and % API 1 and 2 released after 30 min dissolution (n=12, mean  $\pm$  SD) for tablets.

Quality attribute	Batch 1	Batch 2	Batch 3
Granules			
LOD (%)	1.77	1.93	1.91
> 500 $\mu$ m (%)	6.9 (1.8)	7.7 (0.4)	8.1 (3.8)
250 $\mu$ m-500 $\mu$ m (%)	42.0 (4.4)	43.6 (1.7)	41.9 (4.9)
125 $\mu$ m-250 $\mu$ m (%)	38.3 (4.1)	39.4 (2.6)	42.8 (6.3)
75 $\mu$ m-125 $\mu$ m (%)	8.7 (2.0)	5.9 (2.2)	4.2 (3.4)
<75 $\mu$ m (%)	4.0 (0.2)	3.5 (1.1)	3.2 ( 0.5)
Bulk density (g/ml)	0.420 (0.000)	0.460 (0.000)	0.523 (0.006)
Tapped density (g/ml)	0.453 (0.006)	0.480 (0.000)	0.570 (0.000)
Hausner ratio	1.08 (0.01)	1.04 (0.00)	1.09 (0.01)
Tablets			
Weight (mg) (n=20)	428.0 (3.4)	429.5 (2.3)	431.8 (2.5)
Hardness (N) (n=12)	99.6 (8.4)	98.3 (8.1)	90.4 (7.2)
Thickness (mm) (n=12)	5.37 (0.03)	5.37 (0.04)	5.32 (0.02)
Friability (%) (n=8)	0.03 (0.01)	0.02 (0.01)	0.02 (0.01)

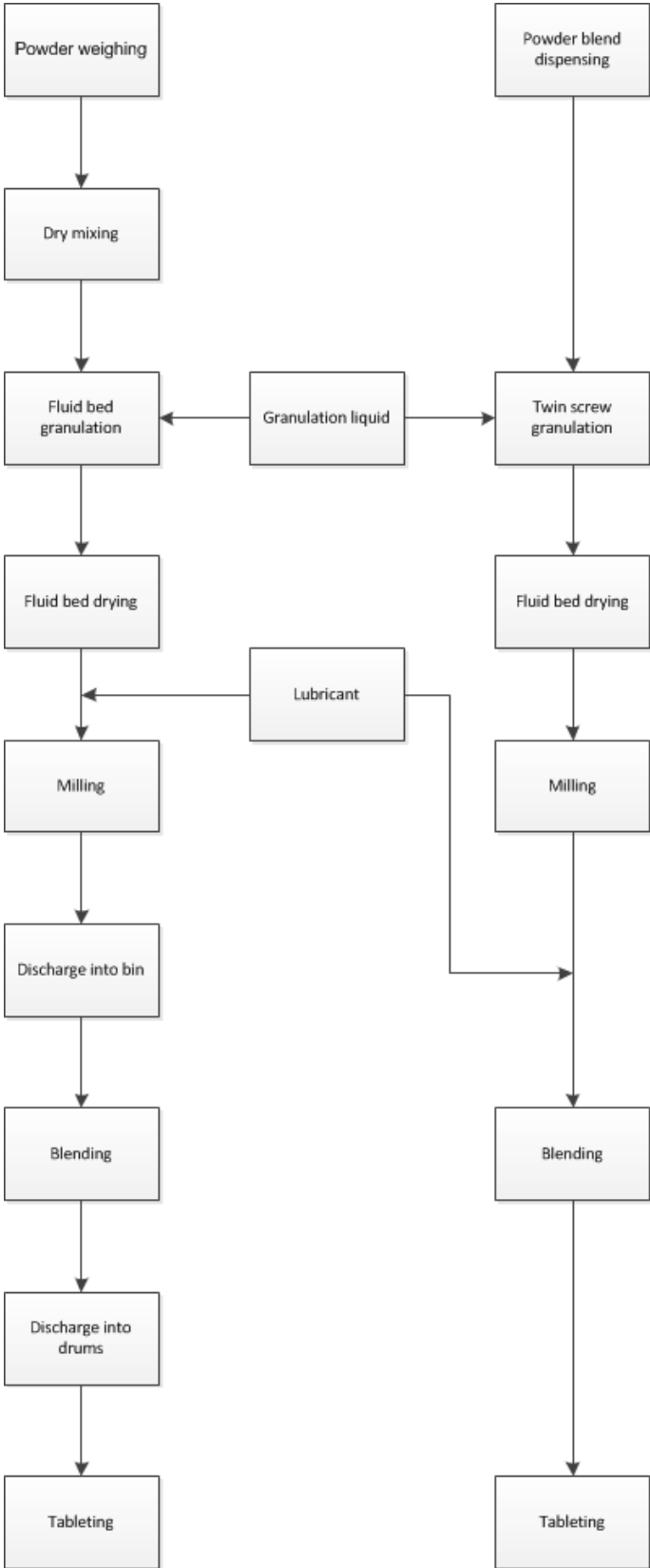

Figure 3: Process flow diagrams for the actual batch process (left) and the continuous process (right).



## Evaluation of granules

### *Loss on Drying (LOD)*

Immediately after collection, the residual moisture content of the milled granules was determined via loss on drying (LOD) using a Mettler LP16 moisture analyser, including an infrared dryer and a Mettler PM460 balance (Mettler-Toledo, Zaventem, Belgium). A sample of approximately 9 g was dried at 105°C until the rate of change was less than 0.1% LOD for 30 seconds and the % LOD was then recorded (n=1). For run 1, LOD measurements of samples taken from the first and last filling cycle of the dryer were performed in triplicate.

### *Particle size analysis*

Sieve analysis was performed using a Retsch VE 1000 sieve shaker (Haan, Germany). Milled granules were placed on the shaker during 5 min at an amplitude of 2 mm using a series of sieves (75, 125, 250, 500 and 1000 µm). The amount of granules retained on each sieve was determined. All granule batches were measured in triplicate. The amount of fines and coarse agglomerates were defined as the fractions <75 and >500 µm, respectively.

### *Friability of granules*

The granule friability was determined (n=3) using a friabilator (PTF E Pharma Test, Hainburg, Germany) at a speed of 25 rpm for 10 min, by subjecting 10 g (lwt) of milled granules together with 200 glass beads (mean diameter: 4 mm) to falling shocks. Prior to determination, the granule fraction <250 µm was removed to assure the same starting conditions. Afterwards, the glass beads were removed and the weight retained on a 250 µm sieve (Fwt) was determined. The friability was calculated as  $((lwt - Fwt) / lwt) * 100$ .

### *Flowability*

The bulk volume ( $V_0$ ) of 30 g milled granules was recorded in a 100 ml measuring cylinder as well as the volume after 1250 taps ( $V_{1250}$ ) in a tapping machine (J. Englesman, Ludwigshafen, Germany) (n=3). Bulk and tapped densities were calculated as  $30 \text{ g} / V_0$  and  $30 \text{ g} / V_{1250}$ , respectively. The Hausner ratio (HR) was calculated from the bulk and tapped density using the following equation,

$$\text{Hausner Ratio (HR)} = \rho_f / \rho_i$$

where  $\rho_i$  is the bulk density and  $\rho_f$  is the tapped density [14]. Flow properties were described accordingly to the range of Hausner ratio described in USP Powder flow <1174> [15].

### **Tablet evaluation**

#### *Weight uniformity, hardness and thickness*

Weight uniformity was determined after weighing 20 individual tablets of each sample taken. The average mass and the amount of tablets deviating by more than 5% and 10% from the average mass were calculated. The hardness and thickness of tablets (n=10) were determined (Sotax HT 10, Basel, Switzerland) after a storage period of at least 24 h at 21 °C and 30% RH.

#### *Friability*

The tablet friability was determined (n=3) using a friabilator described in Eur. Ph. 5.0. (PTF E Pharma Test, Hainburg, Germany), at a speed of 25 rpm for 4 min. The percentage weight loss was expressed as the tablet friability.

#### *Content uniformity, disintegration time and dissolution*

To assess the content uniformity, the individual content of the two active substances of 10 tablets was determined via HPLC analysis. The disintegration time was determined (n=6) using the apparatus described in Eur. Ph. 5.0. (PTZ-E Pharma Test, Hainburg, Germany). Tests were performed in distilled water at  $37 \pm 0.5$  °C using disks. Dissolution tests were performed (n=3) in 900 ml 0.1N HCl (pH = 1) using the paddle method (VK 7010, Vankel, Cary, NC, USA). The temperature of the dissolution medium was maintained at  $37 \pm 0.5$ °C, while the rotation speed was set at 50 rpm. A 5 ml sample was withdrawn at 30 min after starting the dissolution. The content of both drug components was determined via HPLC analysis.

### *HPLC analysis*

API concentrations were determined by a validated reversed phase high-performance liquid chromatography (HPLC)–UV method with gradient. For content uniformity analysis, 10 individual tablets per sample were accurately weighed and placed into a 50 ml volumetric flask. 30 ml of 20 mM potassium phosphate monobasic (PPM) solution was added and mixed for 10 to 15 minutes in order to disintegrate the tablets. After the tablets were completely disintegrated, 20 ml of acetonitrile:methanol (50/50, v/v) was added. Sample solutions were diluted above to volume with PPM solution and mixed. Before filling into the injection vials, the solutions were filtered through a 45 µm PTFE filter.

The HPLC equipment used for analysis was a Waters 2695 Separations Module Alliance system. The Separations Module is an integrated solvent and sample management platform (quaternary solvent, high-performance solvent delivery system). A PDA detector ( $\lambda = 215$  nm) (Waters 2996 PDA Detector) was connected to the Alliance system and a Supelcosil LC-8-DB column (150 mm x 4.6 mm, 5 µm) was used as the silica gel carrier with reversed phase properties. This sorbent was packed into a LiChroCart® 125-4 HPLC cartridge (Merck KGaA, Darmstadt, Germany).

## **RESULTS AND DISCUSSION**

### **Evaluation of granulation, drying and milling processes**

During processing, the ConsiGma™-25 system continuously logged 55 different process parameters/outcomes (1 s interval), supplying a huge amount of data. Fig. 4 shows the evolution of four critical process outcomes during the 5h runs: the torque on the screws of the granulation unit, the temperature of the water at the granulator jacket inlet, the differential pressure over the dryer filters for the dryer module and the temperature of the mill screen for the granule conditioning module. From these graphs, it is clear that for each parameter a stabilization period was needed to reach steady-state conditions. During the initial 30 min of each run, the torque increased from 1.5 to 2.0 Nm (Fig. 4a) due to layering of the screws and the screw chamber wall with powder material. As the granulation process generates heat by friction, the initial layering of the screws and barrel wall with wet mass caused an increase of the barrel wall temperature at the work segment of the granulator

(from 25.0°C to 26.0°C). The temperature of the barrel wall was again down regulated to the setpoint value (25.0°C) by a feedback control system which compensated by a decrease of the water temperature at the granulator jacket inlet (from 26.5 to 21.5°C) (Fig. 4b).

a

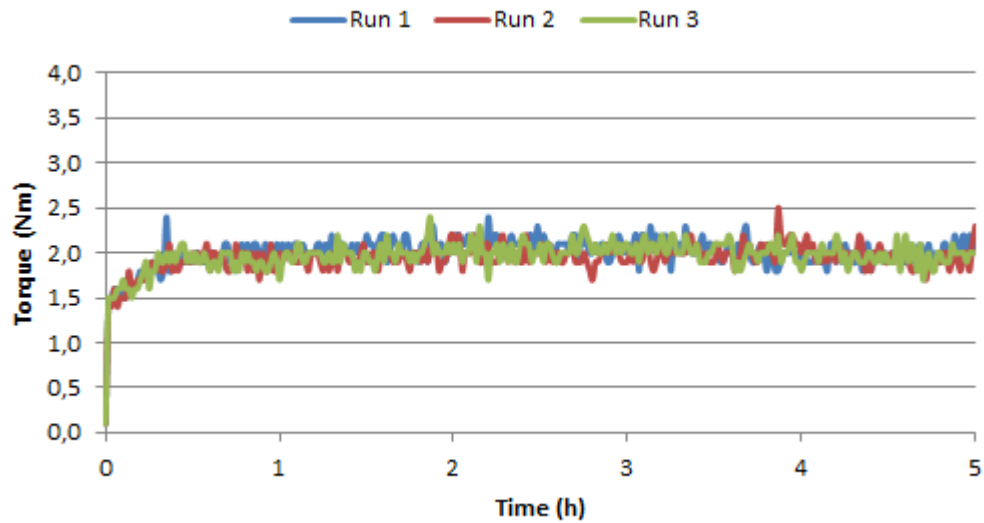

b

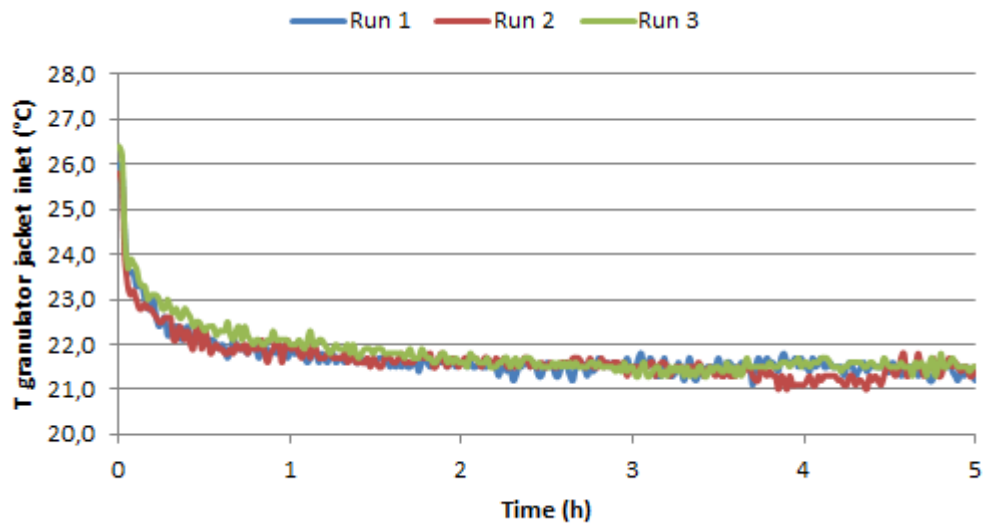

c

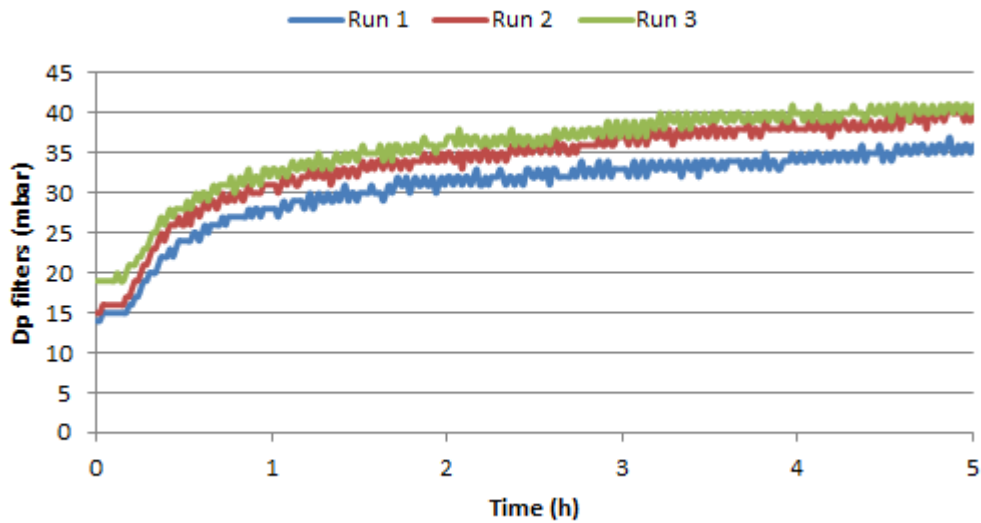

d

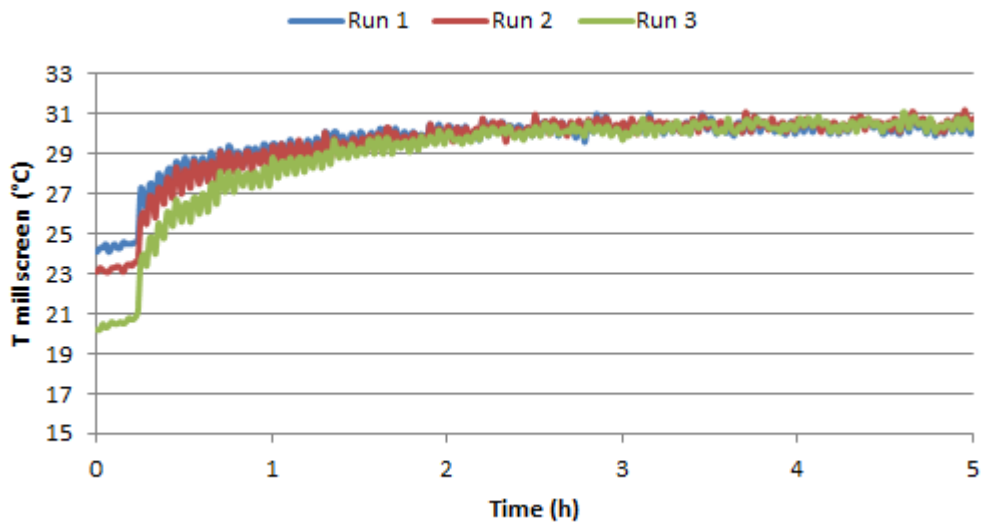

Figure 4: Evolution of critical process outcomes in function of process time: (a) torque, (b) water temperature at the granulator jacket inlet, (c) differential pressure over the dryer filters, (d) temperature of mill screen.

During the 5h production runs, a gradual increase of the differential pressure over the dryer filters was observed due to increased filter loading with fine particles (Fig. 4c). However, the rate of the increase dropped in function of process time: from a 15 mbar increase over the 1st hour to 1 mbar during the last hour. By performing a 19h production run, it was

confirmed that after 8h, a plateau phase for this parameter was reached (data not shown). A limited increase of the temperature of the mill screen was observed during the first part of the process, indicating initial layering of the mill screen (Fig. 4d). All process data trends were found to be highly comparable between the different runs, indicating the excellent repeatability of the system.

### **Evaluation of granule properties**

Different from conventional batch fluid bed drying processes where the drying endpoint is mainly determined by temperature-based monitoring methods [16-20], a fixed drying time for each cell of the segmented dryer unit was applied in order to retain the continuity of the system. LOD values obtained after drying of granules produced by the actual batch process were 1.77%, 1.93% and 1.91% for batch 1, 2 and 3, respectively (Table 1). For the three consecutive continuous runs, the residual moisture content of the dried granules was determined in function of process time. All LOD values approximated the target LOD value (1.5%) and were in compliance with the specifications (1.0-2.0%) of the actual batch process, indicating a stable and reliable drying process (Fig. 5). Besides, the drying capacity was clearly not affected by the increase of the differential pressure over the dryer filters (Fig. 4c). Although the time between the first and the last portion of wet granules entering each cell was 180 seconds (as filling time per cell was equal to 180 seconds), the standard deviation between the different LOD measurements per cell was low (0.01 – 0.08%).

Particle size distributions (PSD) of milled granules were determined. Fig. 6 shows an overview of the evolution of the amount of material on the different sieves in function of process time for run 1. Particle size results were similar over the full length of the runs. However, it can be seen from the results of run 1 that slightly deviating PSD results were obtained during the first filling cycle of the dryer (Fig. 6). During the start-up phase, a lower amount of particles smaller than 250  $\mu\text{m}$  and a higher amount of particles larger than 500  $\mu\text{m}$  were produced. The fraction between 250  $\mu\text{m}$  and 500  $\mu\text{m}$  remained stable. It is suggested that the deviation of PSD observed at start-up was due to the initial layering of the grater type mill screen (as can be seen from Fig. 4d) as a result of which particles encountered more friction yielding a slightly higher amount of fines and smaller amount of

particles larger than 500  $\mu\text{m}$ . PSD results obtained for run 2 and run 3 were similar to the results for run 1 (data not shown).

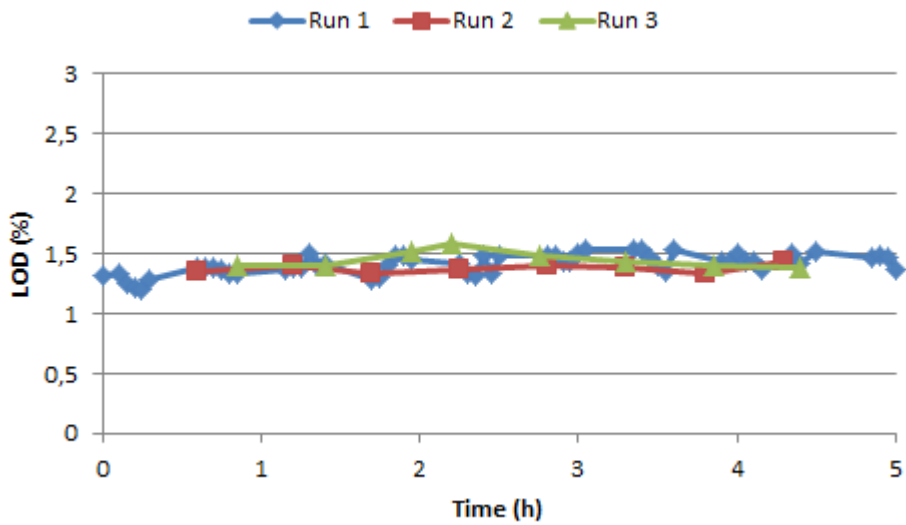

Figure 5: LOD results of milled granules in function of process time.

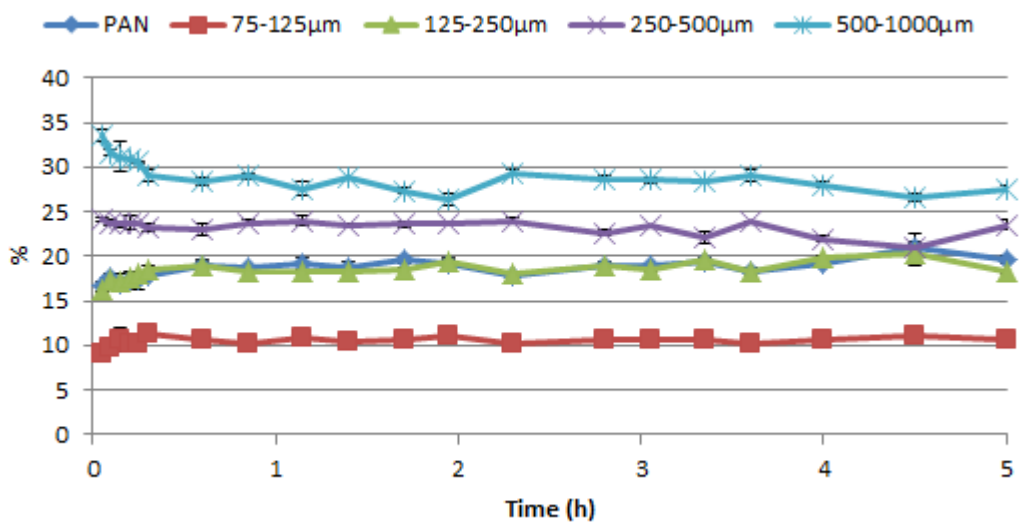

Figure 6: Evolution of particle size distribution of milled granules in function of process time for run 1.

Fig. 7 shows the PSD results obtained from milled granules produced by the continuous twin screw granulation/fluid bed drying process versus the actual batch fluid bed

granulation/drying process (Table 1, PSD results for batch 1). The continuous process resulted in a wider and bimodal PSD, as the PSD consisted of a higher amount of fines ( $F < 75 \mu\text{m}$ ) combined with a higher amount of coarse particles ( $F > 500 \mu\text{m}$ ), in comparison with the unimodal PSD results for the batch fluid bed process. This is in agreement with findings of other researchers who described the appearance of bimodal PSD for granules produced by twin screw granulation [8, 10, 21, 22].

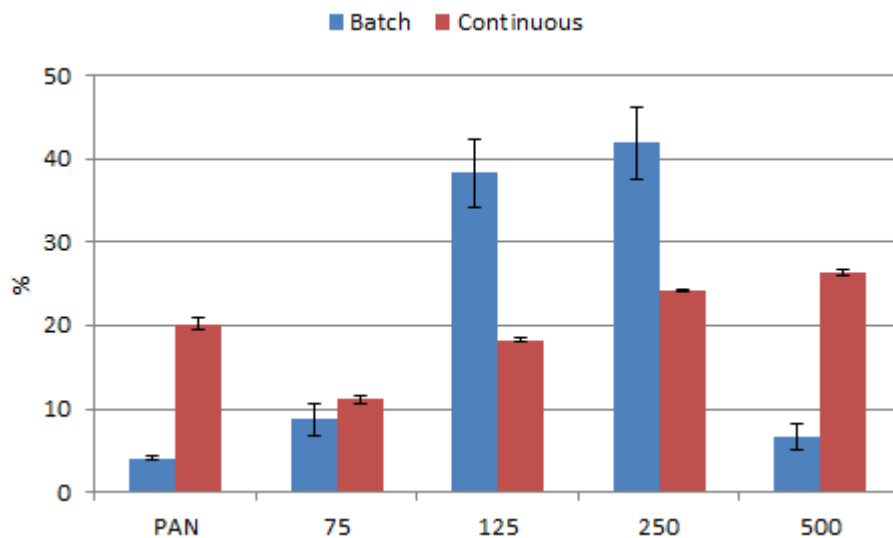
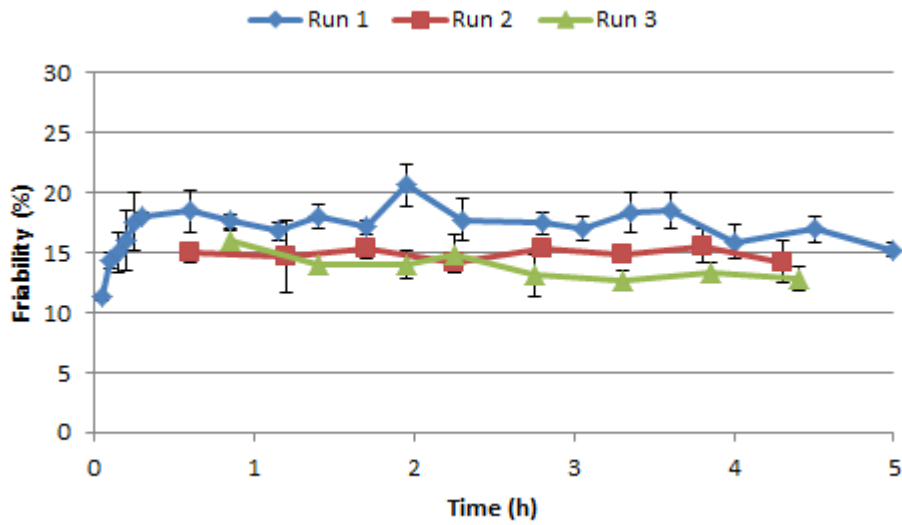

Figure 7: Particle size distribution of milled granules produced by continuous twin screw granulation/drying versus batch fluid bed granulation/drying.

Results for friability and Hausner ratio of milled granules are shown in Fig. 8. For all granules, the friability, an estimate for granule strength, was low (12 to 20%) (Fig. 8a). Due to the low friability, downstream processing problems were avoided. Again, slightly deviating results were obtained during the start-up phase, as shown by the results for run 1. The milled granules obtained during the first filling cycle of the dryer had a lower friability, suggesting that the oversized fraction is milled into smoother granules when the mill is not yet layered during the initial phase of the process. No friability values were recorded for granules produced by the actual batch process.



a



b

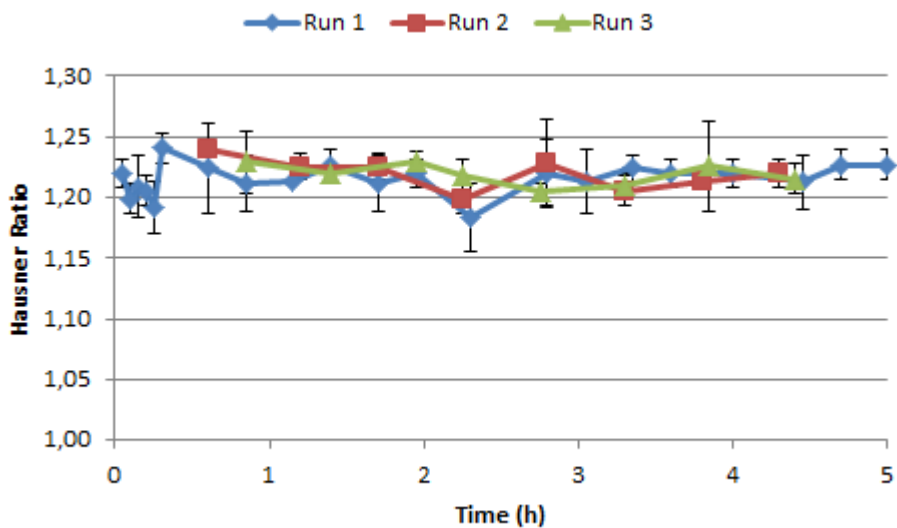

Figure 8: Granule quality attributes in function of process time: friability (a) and Hausner ratio (b).

The results for the bulk densities of continuously produced granules ranged from 0.508 to 0.545 g/ml, and the tapped densities from 0.612 to 0.652 g/ml. Hausner ratio values were calculated from the bulk and tapped densities to describe the flowability of the granules. As the Hausner ratios ranged between 1.18 and 1.24, all granules could be classified as fair flowing (Fig. 8b). The slightly deviating PSD results obtained during the start-up phase of run

1, did not significantly influence the flowability of the granules. The bulk densities of the granules produced by the batch fluid bed granulation/drying process ranged from 0.420 to 0.523 g/ml, whereas the tapped densities ranged from 0.453 to 0.570 g/ml. For the batch process, lower Hausner ratios (1.04 to 1.09) were obtained in comparison to the continuous process. This can be explained by the higher amount of fine particles (<75  $\mu\text{m}$ ) produced by the continuous process which negatively influenced the flow properties (Fig. 7). Besides, several researchers already described the elongated shape of the granules produced by twin screw granulation, while the batch fluid bed process typically resulted in the formation of spherical granules [9, 10, 21, 22].

### **Evaluation of tablet properties**

After milling, granules were transferred to an in-line lubricant blender followed by the production of tablets. Fig. 9 shows an overview of results for weight uniformity and hardness of tablets. Although higher Hausner ratio values were obtained for granules produced by the continuous process in comparison with the batch process, the weight uniformity of these tablets was excellent (Fig. 9a). Mean weight values between 426.1 and 432.3 mg were obtained (maximal RSD-value of 1.12 %RSD for all samples) for the continuous process, whereas mean weight values for the batch process ranged between 428.0 and 431.8 mg (maximal RSD-value of 0.81 %RSD for all samples). Hardness values of tablets produced by the continuous system were stable in function of time (Fig. 9b). Mean hardness values ranged from 78.2 to 94.4 N and were in compliance with the specifications of the actual batch process (70-110 N). Mean thickness values (5.25-5.34 mm) were close to the lower acceptance limit of the batch process (5.30 mm) in order to obtain conforming hardness values. This could be explained by the higher density of the granules produced by twin screw granulation and therefore higher resistance to deformation during tableting. Thickness values for tablets from the conventional process were also low as mean thickness values ranged between 5.32 and 5.37 mm. Compared to the continuously produced tablets, mean hardness values of tablets from the batch process were higher (from 90.4 to 99.6 N). This could be explained by the usage of starch paste as binder during the batch fluid bed granulation process, whereas for the continuous process water was used as granulation liquid. In this way, continuous manufacturing of starch paste could be avoided which decreased the complexity of the continuous process from a practical point of view. No

deviating results for weight uniformity, hardness and thickness were obtained for tablets produced during the start-up and shut down phase of the continuous runs (Fig. 9, run 2).

a

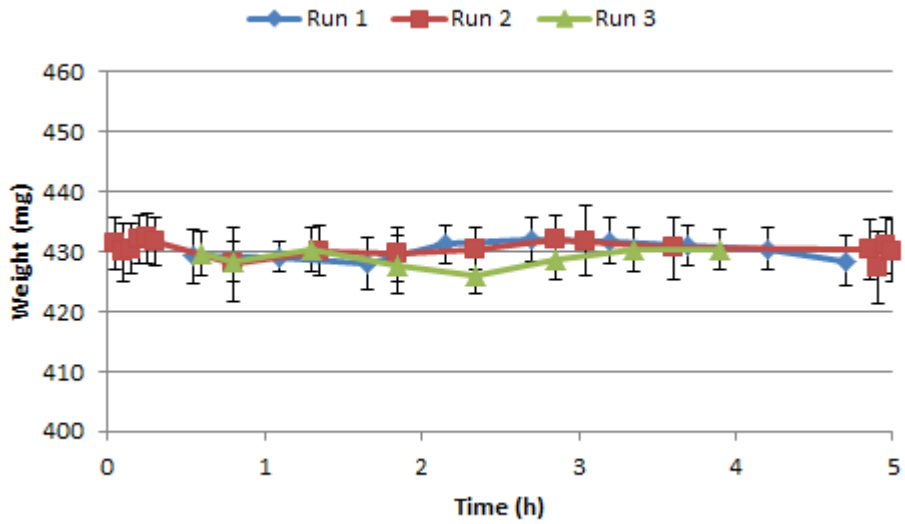

b

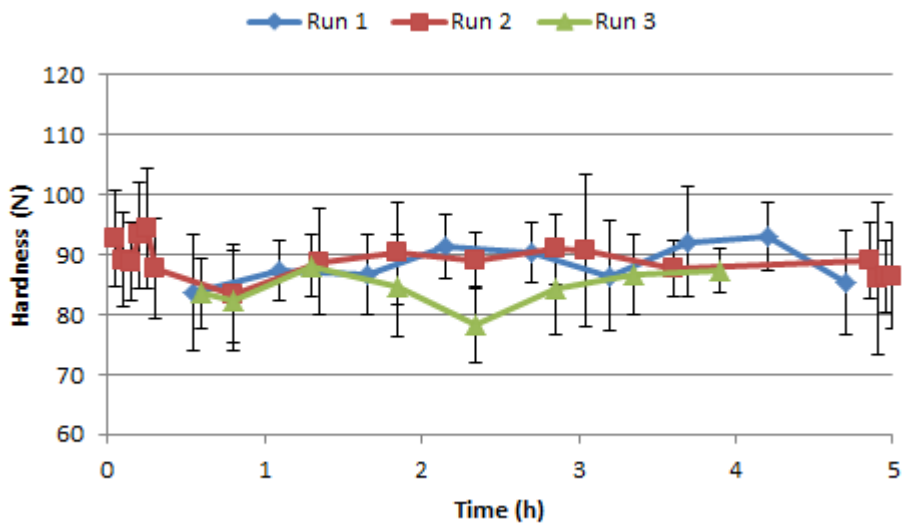

Figure 9: Tablet quality attributes in function of process time: weight uniformity (a) and hardness (b).

Friability was low for all tablets (0.09-0.20%), allowing subsequent coating. Compared to the continuous process, friability was lower for tablets produced by the batch process (0.02-

0.03%). Again, this could be explained by the usage of starch paste as binder during the batch process (see above).

Content uniformity of tablets was determined (samples from beginning, middle and end of run 2). For the continuous as well as for the batch process, all assay results of tablets were within  $\pm 2.5\%$  of the declared potency (data not shown). Mean disintegration times ranged between 123 and 200 seconds and between 176 and 285 seconds for the continuous and the batch process, respectively (Fig. 10 and Table 1). To meet the specifications for dissolution of the actual process not less than 80% of the labeled amount should be dissolved after 30 min. From Fig. 11 and Table 1, it is clear that the fast disintegration of the tablets produced by both processes resulted in a complete release for both APIs after 30 minutes. Similar results for dissolution were obtained for the three consecutive continuous runs (data of run 1 and run 3 not shown). No deviating results for friability, content uniformity, disintegration time, and dissolution were obtained for tablets produced during the start-up and shut down phase (Fig. 11). Hence, waste during start-up and shut down was avoided.

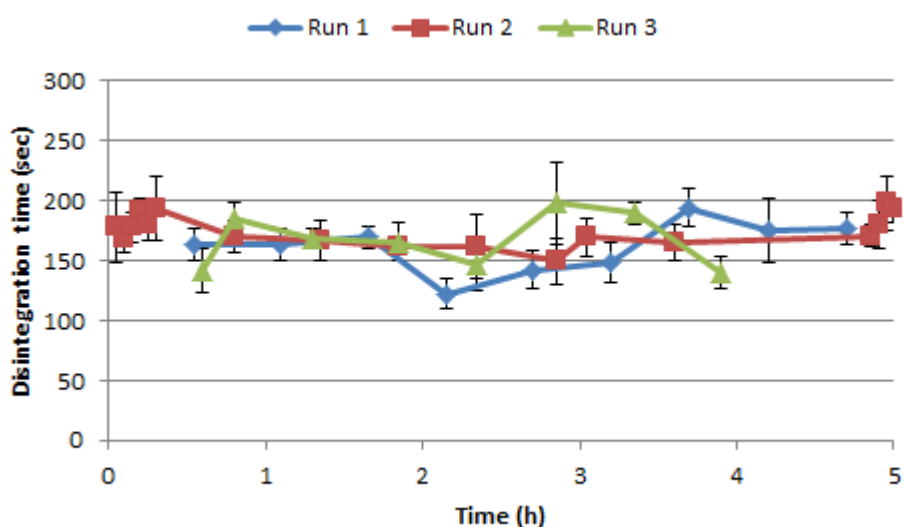

Figure 10: Disintegration time of tablets in function of process time.

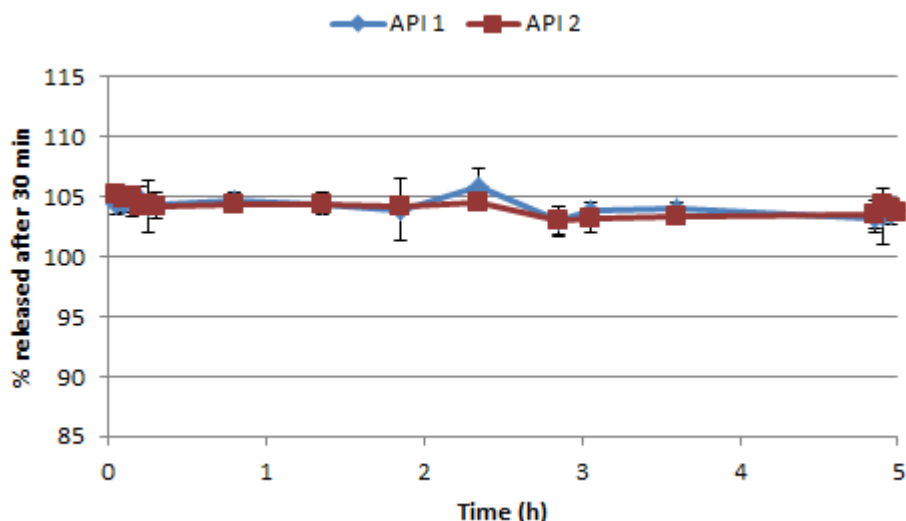

Figure 11: Percentage drug released after 30 min in function of process time for run 2.

## CONCLUSIONS

The results of this study showed a successful process transfer of a commercially available product from a batch fluid bed granulation and drying process to a continuous twin screw granulation and fluid bed drying process. During three consecutive 5h continuous production runs, granule and tablet quality was constant in function of time. Although PSD and Hausner ratio values of milled granules were found to be different for granules produced by the twin screw granulation process compared to the batch fluid bed granulation process, results for critical tablet quality attributes were in compliance with the specifications defined for the batch process.

For each of the investigated process outcomes (torque, water temperature at the granulator jacket inlet, differential pressure over the dryer filters, temperature mill screen) a stabilization period was needed to reach steady-state conditions. However, the granules and tablets produced during start-up were in compliance with the specifications. No deviant granule and tablet properties were detected at the end of each run. Furthermore, process data trends were highly repeatable. Consequently, the ConsiGma<sup>TM</sup>-25 system can be considered as a stable and repeatable system for the continuous production of tablets via wet granulation.

## **ACKNOWLEDGEMENTS**

The authors would like to thank Dr. Tom Van Den Kerkhof and Mr. Stijn Hendrickx for their contribution to the HPLC analysis.

**REFERENCES**

- [1] H. Leuenberger, New trends in the production of pharmaceutical granules: batch versus continuous processing, *European Journal of Pharmaceutics and Biopharmaceutics*, 52 (2001) 289-296.
- [2] FDA-Administration, Guidance for Industry - PAT - A Framework for Innovative Pharmaceutical Development, Manufacturing, and Quality Assurance, 2004.
- [3] C. Vervaet, J.P. Remon, Continuous granulation in the pharmaceutical industry, *Chemical Engineering Science*, 60 (2005) 3949-3957.
- [4] C. Vervaet, J.P. Remon, Continuous Granulation, in: D.M. Parikh (Ed.) *Handbook of Pharmaceutical Granulation Technology*, Informa Healthcare, New York (USA), 2009, 308-322.
- [5] E.I. Keleb, A. Vermeire, C. Vervaet, J.P. Remon, Twin screw granulation as a simple and efficient tool for continuous wet granulation, *International Journal of Pharmaceutics*, 273 (2004) 183-194.
- [6] D. Djuric, P. Kleinebudde, Impact of screw elements on continuous granulation with a twin-screw extruder, *Journal of Pharmaceutical Sciences*, 97 (2008) 4934-4942.
- [7] B. Van Melkebeke, C. Vervaet, J.P. Remon, Validation of a continuous granulation process using a twin-screw extruder, *International Journal of Pharmaceutics*, 356 (2008) 224-230.
- [8] M.R. Thompson, J. Sun, Wet Granulation in a twin-screw extruder: Implications of screw design, *Journal of Pharmaceutical Sciences*, 99 (2010) 2090-2103.
- [9] R.M. Dhenge, J.J. Cartwright, M.J. Hounslow, A.D. Salman, Twin screw granulation: Steps in granule growth, *International Journal of Pharmaceutics*, 438 (2012) 20-32.
- [10] A.S. El Hagrasy, J.R. Hennenkamp, M.D. Burke, J.J. Cartwright, J.D. Litster, Twin screw wet granulation: Influence of formulation parameters on granule properties and growth behavior, *Powder Technology*, 328 (2013) 108-115.

- [11] L. Chablani, M.K. Taylor, A. Mehrotra, P. Rameas, W.C. Stagner, inline real-time near-infrared granule moisture measurements of a continuous granulation–drying–milling process, *AAPS PharmSciTech*, 12 (2011) 1050-1055.
- [12] M. Fonteyne, J. Vercruyse, D.C. Díaz, D. Gildemyn, C. Vervaet, J.P. Remon, T.D. Beer, Real-time assessment of critical quality attributes of a continuous granulation process, *Pharmaceutical Development and Technology*, 18 (2013) 85-97.
- [13] J. Vercruyse, D.C. Diaz, E. Peeters, M. Fonteyne, U. Delaet, I. Van Assche, T. De Beer, J.P. Remon, C. Vervaet, Continuous twin screw granulation: Influence of process variables on granule and tablet quality, *European Journal of Pharmaceutics and Biopharmaceutics*, 82 (2012) 205-211.
- [14] H.H. Hausner, Friction conditions in a mass of metal powder, *International journal of Powder Metallurgy*, 3 (1967) 7-13.
- [15] General Test <1147>, Powder flow, in: *USP32/NF27*, U.S. Pharmacopeial Convention, Rockville, MD, 2009, 688-691.
- [16] M. Alden, P. Torkington, A.C.R. Strutt, Control and instrumentation of a fluidized-bed drier using the temperature-difference technique. Development of a working model, *Powder Technology*, 54 (1988) 15-25.
- [17] A.J. Hlinak, A. Saleki-Gerhardt, An evaluation of fluid bed drying of aqueous granulations, *Pharmaceutical Development and Technology*, 5 (2000) 11-17.
- [18] K.R. Morris, J.G. Stowell, S.R. Byrn, A.W. Placette, T.D. Davis, G.E. Peck, Accelerated fluid bed drying using NIR monitoring and phenomenological modeling, *Drug development and industrial pharmacy*, 26 (2000) 985-988.
- [19] G. Chaplin, T. Pugsley, C. Winters, Application of chaos analysis to pressure fluctuation data from a fluidized bed dryer containing pharmaceutical granule, *Powder Technology*, 142 (2004) 110-120.



[20] G. Chaplin, T. Pugsley, C. Winters, The S-statistic as an early warning of entrainment in a fluidized bed dryer containing pharmaceutical granule, *Powder Technology*, 149 (2005) 148-156.

[21] R.M. Dhenge, R.S. Fyles, J.J. Cartwright, D.G. Doughty, M.J. Hounslow, A.D. Salman, Twin screw wet granulation: Granule properties, *Chemical Engineering Journal*, 164 (2010) 322-329.

[22] R.M. Dhenge, J.J. Cartwright, M.J. Hounslow, A.D. Salman, Twin screw wet granulation: Effects of properties of granulation liquid, *Powder Technology*, 229 (2012) 126-136.



# 6

## **EVALUATION OF POWDER BLENDING IN A TWIN SCREW GRANULATOR: AN EXPERIMENTAL APPROACH**

Parts of this chapter are submitted to International Journal of Pharmaceutics:

J. Vercruyse, M. Fonteyne, A. Kumar, U. Delaet, I. Van Assche, I. Nopens, T. De Beer, J.P. Remon, C. Vervaet, Evaluation of powder blending in a twin screw granulator: an experimental approach.

**Abstract**

Twin screw granulation has been reported as an attractive technology for continuous wet granulation. Typically, a preblend of raw materials is fed to the inlet of the twin screw granulator (TSG) followed by addition of granulation liquid. However, a truly continuous process uses several feeders (each one dosing an individual ingredient) and relies on the mixing capacity of the screws in the granulation unit to homogenize the formulation.

In this study, a binary powder formulation was blended using a continuous high shear twin screw granulator (part of the ConsiGma<sup>TM</sup>-25 system, a fully continuous from-powder-to-tablet manufacturing line from GEA Pharma Systems, Wommelgem, Belgium). The formulation consisted of theophylline as the active pharmaceutical ingredient (API) and lactose as the excipient. Both materials were individually fed into the screw chamber via two separate powder feed ports. Theophylline content of samples collected at the discharge was determined via UV spectroscopy.

Blender performance, characterized by the relative standard deviation (RSD) on theophylline content of samples taken at the blender discharge and by the variance reduction ratio (VRR) of the TSG, was measured as a function of throughput, screw speed and drug load. Furthermore, the influence of particle size of raw materials, screw configuration, addition order of materials and addition of granulation liquid on the blend homogeneity was investigated. Variation in the particle size of raw materials was studied using two grades of theophylline and lactose.

It was observed that the drug load highly influenced the blend homogeneity at the discharge: the lower the drug load, the higher the RSD values. Varying the throughput and screw speed did not affect RSD at the discharge. The addition of kneading elements improved the blending capacity. Decreasing the particle size of the excipient did not have a negative effect on mixing performance because of high shear and de-agglomeration inside the twin screw granulator. Blend homogeneity was better if API was added into the screw chamber before the excipient. Addition of granulation liquid increased axial mixing and therefore improved the blending performance.

KEYWORDS: Continuous processing, Continuous powder mixing, Mixing performance, Blend homogeneity, Design of Experiments

## INTRODUCTION

In the pharmaceutical industry, powder mixing is a crucial intermediate process for manufacturing of solid dosage forms. It is a complex process with multiple variables such as the characteristics of the solids and the design and operating conditions of the mixing equipment [1]. In the current pharmaceutical manufacturing environment, powder mixing is carried out batchwise even when previous or subsequent process steps are continuous (e.g. tableting). However, continuous blending has been used for several years in other industries (e.g. food) which operate at much larger throughputs and with less demanding homogeneity requirements than for pharmaceutical applications [2]. For pharmaceuticals, a powder blend only passes inspection if the relative standard deviation (RSD) of the sample concentrations is under the limit defined in the blend uniformity guidance by FDA [3], i.e. below 5%. Recently, continuous powder mixing is beginning to attract interest in the pharmaceutical industry as it offers several advantages, including smaller equipment size, reduced in-process inventory, less solid handling such as filling and emptying of blenders (limiting the risk of segregation or exposure to toxic pharmaceutical ingredients during handling) and better control around a well-defined steady state [4].

Pernenkil and Cooney [1] published a review on continuous powder mixing. They described that the role of a continuous powder mixer is to mix initially segregated fluxes as well as to attenuate feeding fluctuations. Mixing behavior in the continuous blender can be described as a combination of axial and radial mixing. Axial mixing is important in order to mitigate the variability introduced by the feeding process and can be described using the residence time distribution [5]. Radial mixing is necessary to mix the initially unmixed ingredients to the required degree of homogeneity [4]. Gao et al. [6] mentioned that if the time required for local mixing is longer than the actual residence time of the powder in the system, the process cannot provide a complete mixture, and it fails its designed purpose.

Twin screw granulation has already been described by different researchers as an attractive technique for continuous wet granulation. Typically, feeding of raw materials to the inlet of a twin screw granulator (TSG) is preceded by off-line preblending of the different constituents of the formulation. Although powder dosing into the TSG is possible from a container of preblended material, a truly continuous process uses several feeders (each one dosing an

individual ingredient) and must rely on the in-line mixing capacity of the screws in the granulation unit to homogenize the formulation.

Continuous mixing using the TSG may be less feasible when a large number of components have to be mixed due to space limitations for feeders at the inlet of the granulator and especially due to the very short residence time (order of seconds) and narrow residence time distribution inside a TSG [7-11]. Because of the narrow residence time distribution, axial mixing inside the TSG is rather limited. On the other hand, the intense shear created by the rotating screws promotes radial mixing.

Several researchers [12-14] already reported the feasibility of continuous mixing equipment for pharmaceutical powders. These blenders, commercialized by different vendors (e.g. GEA, Gericke, Glatt, Lödige), typically have a tubular design and a single shaft with paddles for mixing. In order to avoid preblending of raw materials before twin screw granulation, a tubular design blender could be coupled to a TSG. In this way, the blend at the outlet of the continuous blender could be transported by gravity to a loss-in-weight feeder which then feeds the blend to the inlet of the TSG. Alternatively, the blending capacity of the rotating screws inside the TSG could be used to homogenize a limited number of components. For example, when handling an active pharmaceutical ingredient (API) with high toxicity, it could be preferable to use a separate feeder dosing the API, next to a second feeder containing a preblend of excipients. In this case, the API should not be preblended off-line and exposure to API during preblending could be avoided.

The aim of the current study was to experimentally investigate the powder blending capacity of a TSG for a mixture of theophylline (as an example of an active pharmaceutical ingredient, API) and  $\alpha$ -lactose monohydrate (as a commonly used filler). Individual components (API and filler) were dosed to the screw chamber by separate feeders. A design of experiment approach (DoE) was used to investigate the influence of throughput, screw speed and drug load on the mixing performance. Furthermore, additional experiments were performed to evaluate the influence of particle size of raw materials, granulator screw configuration, addition order of materials and addition of granulation liquid. The blending performance was characterized in terms of the homogeneity of the output stream.

## MATERIALS AND METHODS

### Materials

Theophylline anhydrate was used as a model API. Two different grades of theophylline anhydrate (grade 1 and grade 2) were kindly donated by BASF (Ludwigshafen, Germany).  $\alpha$ -lactose monohydrate (Pharmatose® 100M and 200M), a frequently used filler for granulation and tableting, was purchased from Caldic (Hemiksem, Belgium).

### Particle size analysis of powders

The particle size distribution (PSD) of the powders was measured by means of laser diffraction. The wet dispersion method using the 300 RF lens (Malvern Instruments, Malvern, UK) was applied. Powder samples were dispersed in Miglyol 812 (triglycerida saturata media) (Fagron, Capelle aan den IJssel, The Netherlands) with 0.2% Tween 80 (Polysorbate 80) (BUFA, IJsselstein, The Netherlands). Measurements were performed in triplicate. PSD results are given as  $d_{10}$ ,  $d_{50}$  and  $d_{90}$  values.

### Flowability of powders

The flowability of the raw materials was measured using the RST-XS Schulze ring shear tester (Schulze Schüttgutmesstechnik, Wolfenbüttel, Germany). The applied normal load at pre-shear was 2000 Pa. Subsequently, shear stresses of 400, 1000, 1600 and again 400 Pa were applied. The flow function coefficient (ffc), which is the ratio of consolidation stress to unconfined yield strength, was used to evaluate the flowability. Measurements were done in triplicate.

### Experimental set-up

Experiments were performed using a 25-mm co-rotating twin screw granulator (TSG, part of the ConsiGma™-25 system, a fully continuous from-powder-to-tablet manufacturing line from GEA Pharma Systems, Wommelgem, Belgium). The length-to-diameter ratio of the screw chamber is 20:1. API and filler were individually dosed by K-Tron KT20 feeders (K-Tron Soder, Niederlenz, Switzerland) to the screw chamber (Fig. 1). During the experiments, the powder feed rate of the API feeder was monitored (1s interval). Sufficient materials were



pre-loaded in the feeders to avoid interruption of the experiments due to re-filling the feeders. Due to the drag force imposed by the rotating screw elements, materials were axially transported along the barrel length (from the entrance to the discharge). As the TSG did not operate at an inclination ( $0^\circ$  incline), powder flow along the axial direction was neither promoted nor hindered by the gravitational forces. Except otherwise mentioned, no granulation liquid was introduced during processing.

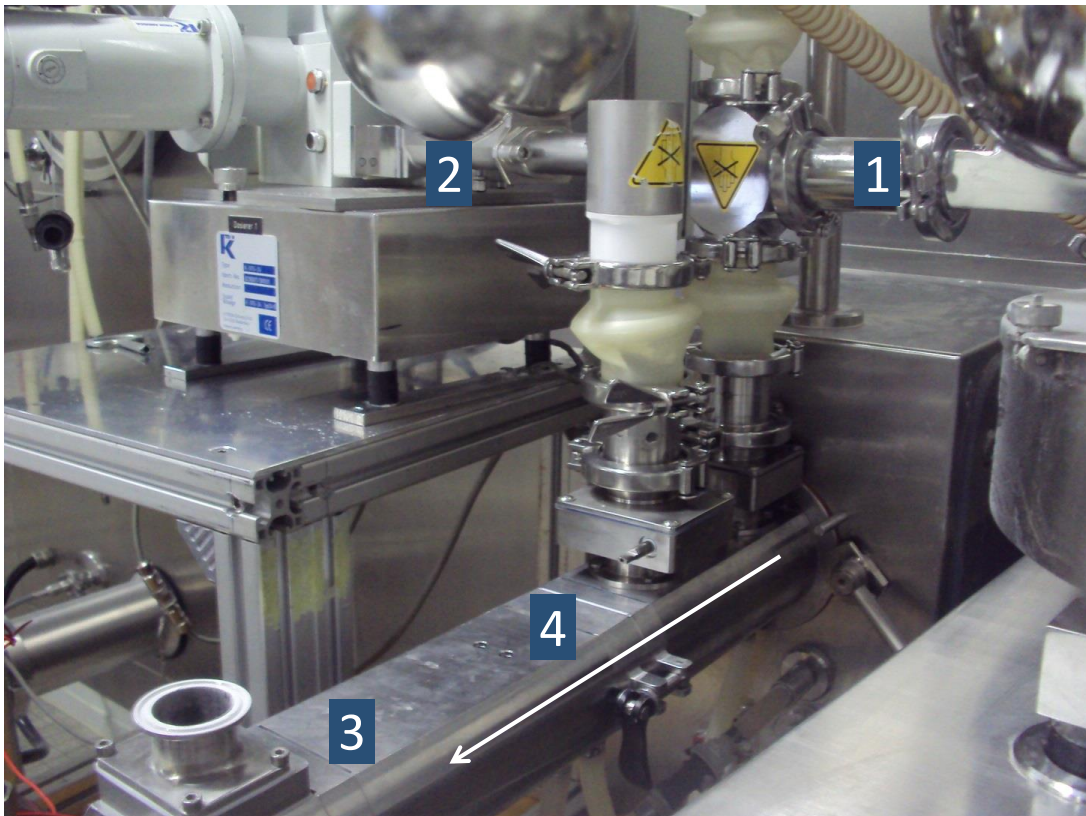

Figure 1: Representation of experimental set-up: 1. API feeder (position 1), 2. excipient feeder (position 2), 3. Twin screw granulator, and 4. Liquid addition ports.

## Experimental conditions

### *Design of experiments*

A central composite face-centered (CCF) experimental design (17 runs) was conducted in order to investigate the influence of throughput (10 – 25 kg/h), screw speed (600 - 950 rpm) and drug load (10 – 30 %) on the mixing capacity of the TSG. Three replicates of the design center point were run. Binary mixtures were prepared by feeding theophylline grade 2 and lactose 200M separately to the screw chamber. The granulator screws consisted of transport

elements only. The different factor settings for each run are listed in Table 1. The results were evaluated with MODDE 9.0 software (Umetrics, Umeå, Sweden). Statistical analysis (specifically, analysis of variance – ANOVA) was used to examine the significance of main factors and their interactions.

*Influence of particle size, screw configuration and addition order of materials*

In addition to the experimental design described above, experiments were performed to study the influence of particle size of raw materials, granulator screw configuration and addition order of materials on blend homogeneity at the discharge. Based on the outcome of the CCF experimental design (2.5.1.), these experiments were performed by using the settings of run 1 (30% drug load) and 11 (10% drug load) (Table 1). Furthermore, to study the blending of low-dosed components, experiments at 4% drug load were added.

Mixing efficiency is not only determined by equipment or process parameters from the equipment but also by the flow properties of the materials to be blended [15]. Mixing is particularly affected by variations in PSD, which impact both the flow properties and segregation tendencies of powder blends. As cohesive powders (size range: 0.5-200  $\mu\text{m}$ ) are very common in the production of pharmaceuticals [1], blending of different theophylline and lactose grades was performed (Table 2).

Table 1: Overview of factor settings from the experimental design.

Run	Throughput (kg/h)	Screw speed (rpm)	Drug load (%)	RSD input (%)	RSD output (%)
1	25	600	30	missing value	2.6
2	25	950	10	0.7	5.4
3	10	600	30	0.7	5.0
4	25	950	30	0.2	3.9
5	10	950	10	2.5	12.0
6	17.5	775	20	1.0	6.7
7	10	600	10	3.3	13.2
8	10	950	30	0.7	4.2
9	17.5	775	20	0.9	3.9
10	17.5	775	20	3.1	10.0
11	25	600	10	1.3	4.6
12	17.5	950	20	1.4	6.8
13	17.5	775	10	missing value	15.3
14	17.5	775	30	0.4	2.4
15	10	775	20	5.5	9.8
16	25	775	20	0.5	9.0
17	17.5	600	20	0.9	15.4

Table 2: Overview of  $d_{10}$ ,  $d_{50}$  and  $d_{90}$  values (determined by laser diffraction) and the ffc values (determined by ring shear cell measurements) for the different raw materials.

Material grade	$d_{10}$ ( $\mu\text{m}$ )	$d_{50}$ ( $\mu\text{m}$ )	$d_{90}$ ( $\mu\text{m}$ )	ffc
Theophylline grade 1	2.1	21.5	48.6	1.4
Theophylline grade 2	4.2	40.1	93.5	3.3
Pharmatose <sup>®</sup> 100M	58.2	155.0	295.8	6.0
Pharmatose <sup>®</sup> 200M	3.4	35.0	108.0	2.6

As the importance of screw configuration on the mixing of powder and liquid phase during twin screw granulation was already described [10], it was evaluated whether the addition of kneading elements or modified transport elements (Fig. 2) to the conveying elements was beneficial for the blending capacity. The screw configurations used in this study are schematically represented in Fig. 3. The performance of screws consisting of only conveying elements was compared to screws with one or two blocks of six kneading elements each ( $L/D = 0.25$  per kneading element) at  $60^\circ$  stagger angle and to screws with two modified transport elements ( $L/D = 1$  per element). If two kneading blocks were applied, both zones were separated by a conveying element ( $L/D = 1.5$ ). Except otherwise mentioned, API was fed into the first feeder port (position 1) of the screw chamber, followed by the addition of excipient through a second feeder port (position 2). To evaluate the importance of the addition order of materials to the screw chamber, the influence of changing feed position of the API and excipient was evaluated.

#### *Influence of liquid addition*

Besides dry blending of powders, additional experiments were performed where distilled water as granulation liquid was added via the liquid addition ports (Fig. 1). Theophylline grade 2 and lactose 200M were used. The screw configuration (Fig. 3, configuration 3) consisted of 2 kneading blocks of 6 kneading elements each ( $60^\circ$  stagger angle) separated by a conveying element ( $L/D = 1.5$ ) and the same process settings as described for the previous section were used. The liquid-to-solid ratio was 0.1. Wet granules were sampled as described below and oven dried ( $40^\circ\text{C}$ , 24h) prior to further analysis.

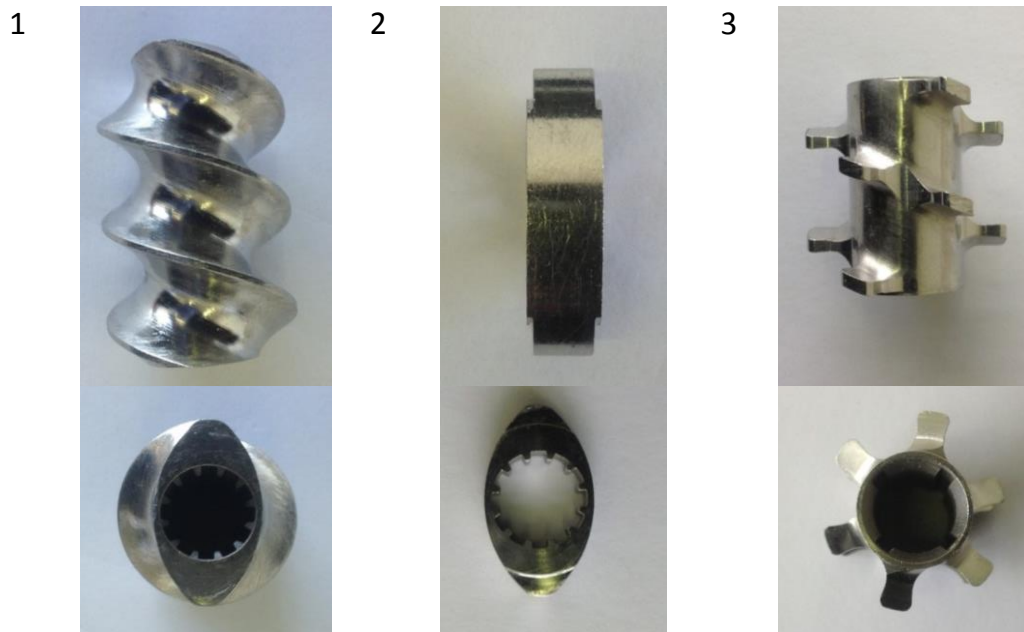

Figure 2: Representation of screw elements: 1. Transport element, 2. Kneading element, and 3. Modified transport element.

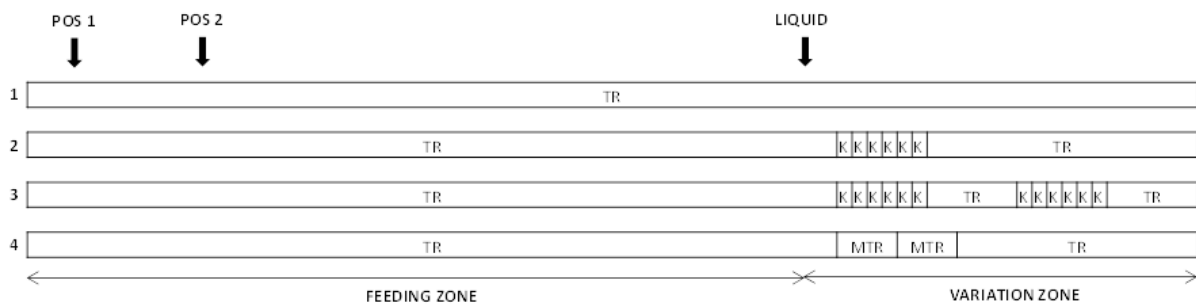

Figure 3: Screw configuration scheme: screws consisting of only transport elements (1), screws with 1 or 2 blocks of six kneading elements each (2 and 3, respectively) and screws with modified transport elements (4). TR: transport zone; K: kneading element; MTR: modified transport element; pos 1: powder feeder at position 1; pos 2: powder feeder at position 2.

**UV assay**

As the acceptance requirement of a blend is based on the relative standard deviation of the concentration of the component of interest in the blend, usually the API, the influence of processing and formulation parameters on the homogeneity of the powder flow from the granulator was determined by analyzing theophylline content of samples retrieved from the

powder flow as a function of time. UV spectroscopy, considered as a standard method for the determination of blend uniformity, was used. A calibration curve for theophylline was made over the range 0 - 18 µg/ml and fitted using linear regression with  $R^2 > 0.99$ . For each experimental condition samples ( $\pm 5$ g) were taken every 30 seconds over a 5 min period. For each sample taken, the API content of three accurately weighed subsamples ( $300 \pm 10$  mg) was determined off-line via UV/VIS-spectroscopy ( $\lambda = 272$  nm). In the pharmaceutical industry, the scale of scrutiny is usually chosen to be maximum 3 times the equivalent mass of a tablet. In this study, the scale of scrutiny was 300 mg referring to a tablet weight of 100 mg. The UV spectroscope used was a Shimadzu UV-1650 PC spectrometer. No significant interference with lactose was observed for the UV absorption reading.

### Characterisation of blending performance

The blending performance was characterized in terms of the homogeneity of the output stream, measured by the relative standard deviation (RSD) and the variance reduction ratio (VRR). The relative standard deviation (RSD) between the theophylline concentrations, which is also known as the coefficient of variability and is the most common mixing index used in industry, was calculated using the following relationship:

$$\text{RSD} = \frac{s}{\bar{C}} = \sqrt{\frac{\sum_1^N (C_i - \bar{C})^2}{N-1}} \cdot \frac{1}{\bar{C}} \quad (1)$$

In this formula,  $\bar{C}$  is the average concentration of the total samples (N) collected in each run and  $C_i$  is the concentration of each sample;  $s$  is the estimate of the standard deviation obtained using the sample concentrations. Lower RSD values mean less variability between samples, which implies better mixing.

For continuous blenders, variability in the feeding rate of the materials often significantly contributes to the variability of the final mixture. Therefore, Danckwerts [16] introduced the variance reduction ratio (VRR) to describe to what extent variability of input can be decreased or eliminated within the blending unit. The VRR was calculated as follows:

$$VRR = \frac{s_i^2}{s_o^2} \quad (2)$$

where  $s_i^2$  is the variance in concentration at the inlet and  $s_o^2$  is the variance at the outlet.  $s_i^2$  changes only when the input flow rate is changed. The larger the VRR, the more efficient the mixing system, since inflow fluctuations are reduced. For each experimental condition, both indices RSD and VRR were computed.

## RESULTS AND DISCUSSION

### Raw material characterization

Table 2 summarizes the  $d_{10}$ ,  $d_{50}$  and  $d_{90}$  values for the PSD together with the ffc values of all the raw materials used in this study. Compared to theophylline grade 1, theophylline grade 2 has a wider PSD and a larger  $d_{50}$ . According to the ffc values, theophylline grade 1 and grade 2 can be classified as very cohesive and cohesive, respectively. For the lactose grades, the 200M grade has a lower  $d_{50}$  compared to the 100M grade. Based on the ffc values, lactose 200M is classified as cohesive while 100M is easy-flowing.

### Influence of throughput, screw speed and drug load

Since the residence time of materials inside the screw chamber of a TSG is very short (in order of seconds) [7-9], the performance of feeders transporting the material to the screw chamber is crucial. Therefore, the powder feed rate stability from the API feeder, expressed as the RSD of the powder feed rate which is a measure of the fluctuations from the mean value, was determined for each run (RSD input). The actual feed rate of the API feeder during each run was determined by both the total throughput and the drug load. It is generally known that feeders operate more stable at higher powder feed rates. Indeed, it was observed that the RSD for powder feed rate (RSD input) was significantly affected by the throughput as well as the drug load (Fig. 4a). At low throughput (10 kg/h) and drug load (10 %) the highest RSD values for powder feed rate were obtained (2.5 % and 3.3 % for run 5 and 7, respectively), whereas at high throughput (25 kg/h) and drug load (30 %) the RSD for powder feed rate was low (0.2 % for run 4) (Table 1).

a

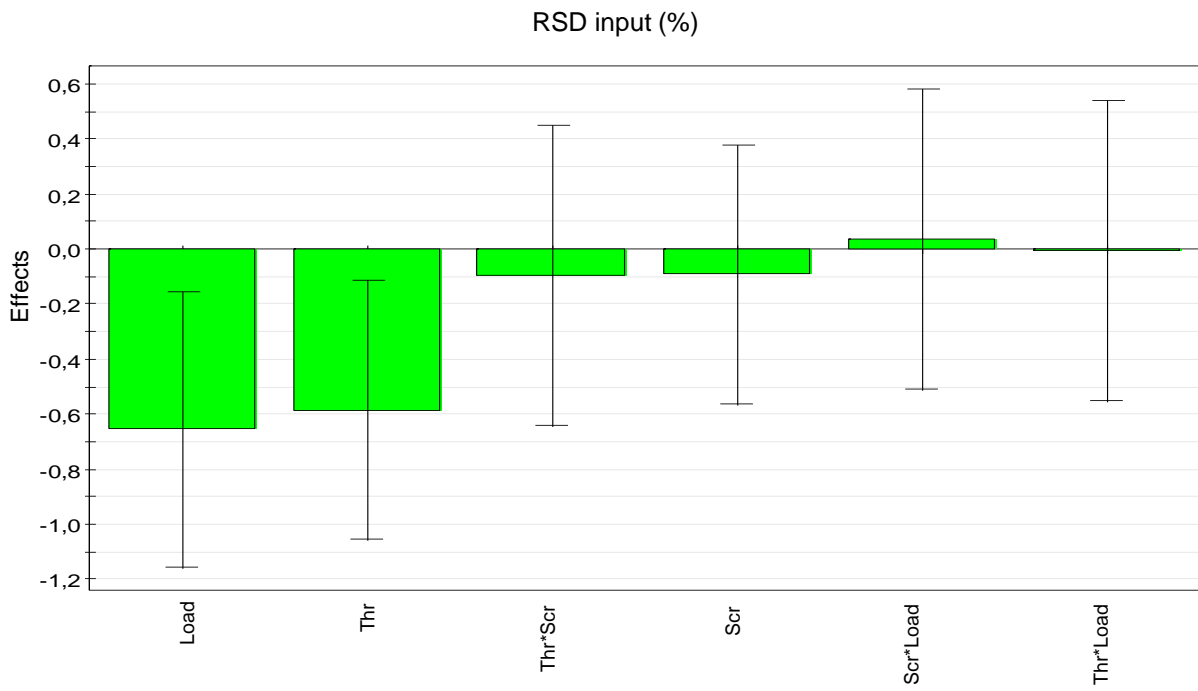

b

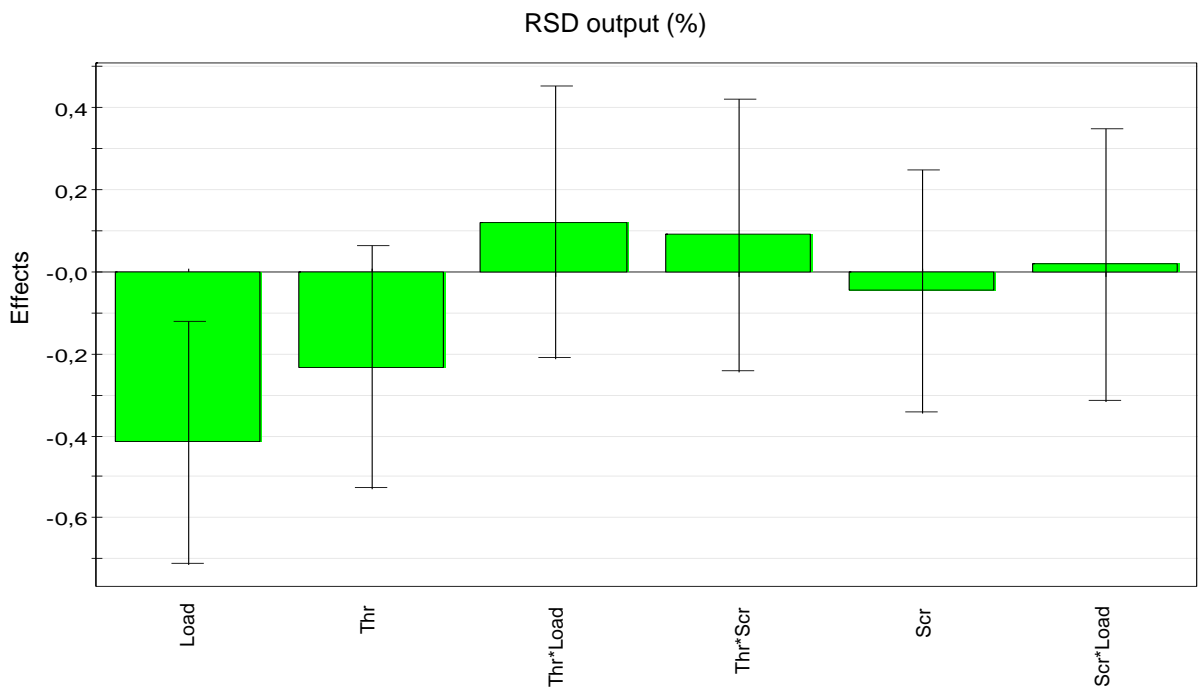

Figure 4: Effect plots for (a) RSD input and (b) RSD output. Load: drug load; Thr: throughput; Scr: screw speed.



From the CCF experimental design, the drug load turned out to be the only significant factor for the RSD at the discharge (Fig. 4b). At 10% drug load, RSD at the discharge varied between 4.6% and 15.3%, while at 30% drug load, RSD values between 2.4% and 5.0% were obtained. This means that for the runs performed with 30% drug load, the RSD at the discharge met the requirement defined by the FDA guidance ( $RSD \leq 5\%$ ) [3]. Fig. 5 illustrates the surface plot for RSD at the discharge as a function of throughput and drug load.

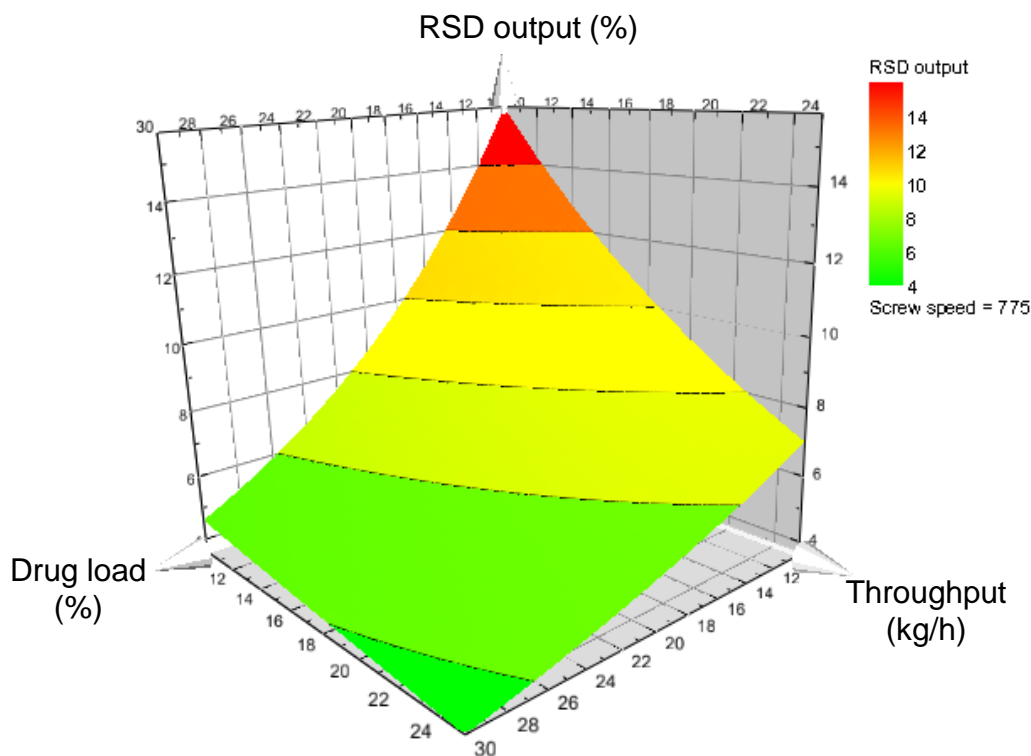

Figure 5: Surface plot for RSD at the discharge as a function of throughput and drug load.

As the feed rate stability (RSD input) was lower for runs with low drug load and low throughput, it was investigated whether the higher RSD at the discharge obtained for these runs could be attributed to the lower feeder performance. Therefore, the VRR, which is a measure of the capability of the TSG to smooth out fluctuations in the composition of the input stream, was calculated. It was observed that VRR was not significantly influenced by the drug load (0.193 and 0.138 for 10% and 30% drug load, respectively) since both the input and output variability were affected by changing the drug load: a lower drug load resulted in higher input (0.5% and 2.0% for 30% and 10% drug load, respectively) as well as higher output variance (3.6% and 10.1% for 30% and 10% drug load, respectively). This indicated

that the higher output variance at the lower drug load could be mainly attributed to inferior feeder performance, next to the inherent lower drug load in the binary mixtures as it is more difficult to homogeneously distribute a low-dosed component. Furthermore, the analytical method error is expected to be higher at low drug concentrations [16, 17].

VRR was only significantly influenced by varying the throughput. Although materials were fed more constantly to the screw chamber at higher throughput, the RSD at the discharge was less affected by the large change in input variability. At low throughput, RSD values at the discharge ranged between 4.2% and 13.2% and at high throughput between 2.6% and 9.0%. So, if the throughput was higher, the variance at the input decreased (from 2.5% to 0.7%) and the variance at the output remained fairly constant. Consequently, at higher throughput, the VRR decreased (from 0.287 to 0.132 at 10 kg/h and 25 kg/h, respectively) which means that the extra variability contributed to the feeding at low versus high throughput was mostly filtered out by the TSG.

Obviously, if the screw speed increased, the conveying rate increased and the time the materials spent in the granulator was reduced [9]. However, changing the screw speed did not affect the powder feed rate stability nor the variability at the discharge. This indicated that within the studied range of screw speeds (600 - 950 rpm), mixing performance was robust.

### **Influence of particle size**

To investigate the effect of powder PSD and cohesion on mixing efficiency, binary mixtures of different theophylline (grade 1 and 2) and lactose (200M and 100M) grades were processed. RSD values for the different experiments are shown in Fig. 6. It is clear that the blend uniformity was better for mixtures formulated with lactose 200M compared to lactose 100M. This showed that the more cohesive lactose 200M grade could be efficiently dispersed by the rotating screws and therefore did not affect the mixing performance. Twin screw granulators impart high shear conditions particularly beneficial for cohesive materials, which may otherwise agglomerate [2]. Furthermore, as the PSD of lactose 200M is more similar to the PSD of both theophylline grades (Table 2), the segregation tendency of these mixtures during analysis was lower.

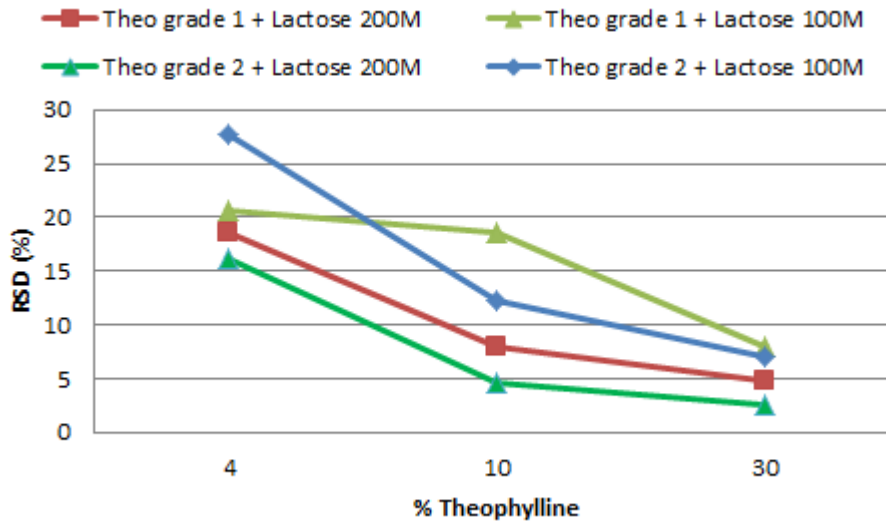

Figure 6: RSD at discharge from experiments conducted with different drug loads (4, 10 and 30%) and theophylline (grade 1 and 2) and lactose grades (200M and 100M).

#### Influence of screw configuration

Several screw configurations were examined to determine whether mixing performance inside the TSG could be enhanced. For twin screw wet granulation, it is known that kneading elements are needed to intensively mix the powder and liquid phase [10]. In the current study, it was investigated whether addition of kneading elements (1 and 2 zones of 6 kneading elements each) or modified transport elements (2 elements) (Fig. 2 and 3) to screws consisting of only transport elements could improve the dry powder blending performance of the TSG. Modified transport elements were implemented in order to alter the flow patterns of powders inside the screw chamber.

Fig. 7 represents RSD values for binary mixtures of theophylline grade 2 and lactose 200M for the different screw configurations. Addition of kneading elements improved the outflow homogeneity at low drug load (4%). Kumar et al. [11] described that increasing the number of kneading elements reduced the axial mixing inside the screw chamber, as kneading zones are fully filled plug flow zones and therefore prevent back-mixing. However, kneading elements showed a distributive mixing effect in the radial direction leading to better homogeneity. Addition of a second kneading zone could not further increase the blend homogeneity, compared to a single kneading zone. Furthermore, it can be seen from the

results that addition of modified transport elements did not result in lower RSD values compared to the conventional transport elements. It is hypothesized that altering the flow patterns of the powders by the modified transport elements was limited as at the applied screw speed (600 rpm), it is suggested that the powder bed will be at least partially fluidized in the TSG.

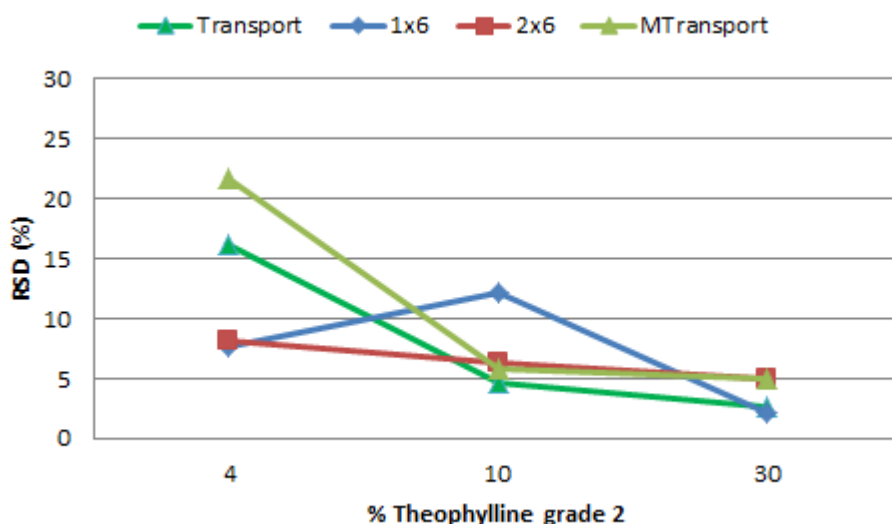

Figure 7: RSD at discharge from experiments conducted with different drug loads (4, 10 and 30 %) and screw configurations: screws consisting of only transport elements (Transport), 1 and 2 kneading zones of 6 kneading elements each (1x6 and 2x6), and screws with modified transport elements (MTransport).

### Influence of addition order

As can be seen from Fig. 1, the API feeder (position 1) was positioned in front of the excipient feeder (position 2) across the length of the screw chamber. So, theophylline was introduced in the screw chamber before lactose. Two additional runs were performed at different drug loads (4% and 30%) and using granulator screws consisting of only transport elements where the position of the feeders was switched. From the results, it turned out that at both drug loads the RSD values were lower if theophylline was added to the screw chamber at position 1. RSD decreased from 27.8% to 15.6% at 4% drug load and from 8.1% to 2.6% at 30% drug load. This suggests that it is more difficult to distribute theophylline in the lactose bulk feed than vice versa as in the latter set-up (i.e. addition of theophylline in

position 1) the cohesive theophylline powder was already fluidized and de-agglomerated by the rotation of the granulator screws before lactose was added.

### Influence of liquid addition

During twin screw granulation, the powder phase is transported to the location where the granulation liquid is added (Fig. 1), followed by intensive distributive mixing of the liquid and powder phase by kneading elements. Therefore, it was investigated if the RSD at the discharge was affected when granulation liquid (i.e. water) was added. From Fig. 8, it can be seen that for 4% drug load, addition of granulation liquid did not affect the RSD at the discharge. For the higher drug load (10% and 30%), the RSD at the discharge was lower when granulation liquid was added to the powders. Dhenge et al. [7] described that the mean residence time increased and the residence time distribution was wider at a higher liquid-to-solid ratio, thus indicating more axial mixing and resulting in lower RSD values.

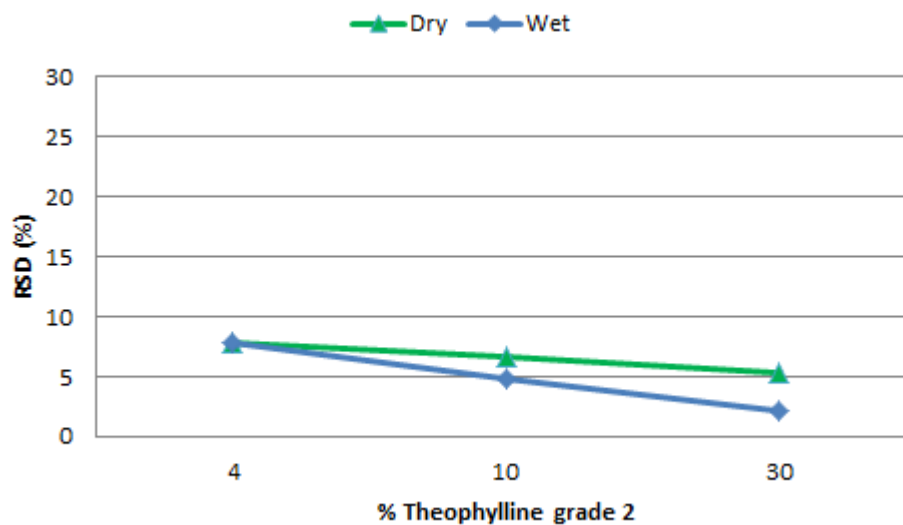

Figure 8: RSD at discharge from experiments conducted with (wet) and without (dry) addition of granulation liquid.

**CONCLUSIONS**

For the preparation of binary powder mixtures with a twin screw granulator, the drug load significantly influenced the blend homogeneity at the outlet of the screw chamber as it was more difficult to acquire stable feeding and homogenous distribution of low-dosed components. Blend homogeneity at the discharge was not affected by varying the throughput and the screw speed. The addition of kneading elements to the screw configuration improved the blending capacity as this intensified distributive mixing of materials. Furthermore, decreasing the particle size of the excipient did not have a negative influence on mixing performance because of high shear and de-agglomeration inside the twin screw granulator. Blend homogeneity was better if the API was added in the screw chamber before the excipient. Addition of granulation liquid increased axial mixing and therefore improved the blending performance.

This study showed that feeding API and excipient separately to a twin screw granulator can be a valid alternative to preblending of all constituents of the formulation prior to twin screw granulation. However, due to the very short residence time and narrow residence time distribution inside a twin screw granulator, axial mixing is rather limited. Therefore, attention should be paid to the performance of feeders as input variability is crucial.

**REFERENCES**

- [1] L. Pernenkil, C.L. Cooney, A review on the continuous blending of powders, *Chemical Engineering Science*, 61 (2006) 720-742.
- [2] P.M. Portillo, M.G. Ierapetritou, F.J. Muzzio, Effects of rotation rate, mixing angle, and cohesion in two continuous powder mixers-A statistical approach, *Powder Technology*, 194 (2009) 217-227.
- [3] Guidance for Industry ANDAs: Blend Uniformity Analysis, FDA (1999).
- [4] A.U. Vanarase, F.J. Muzzio, Effect of operating conditions and design parameters in a continuous powder mixer, *Powder Technology*, 208 (2011) 26-36.
- [5] E.B. Nauman, Residence time theory, *Industrial & Engineering Chemistry Research*, 47 (2008) 3752-3766.
- [6] Y.J. Gao, F.J. Muzzio, M.G. Ierapetritou, Optimizing continuous powder mixing processes using periodic section modeling, *Chemical Engineering Science*, 80 (2012) 70-80.
- [7] R.M. Dhenge, R.S. Fyles, J.J. Cartwright, D.G. Doughty, M.J. Hounslow, A.D. Salman, Twin screw wet granulation: Granule properties, *Chemical Engineering Journal*, 164 (2010) 322-329.
- [8] A.S. El Hagrasy, J.R. Hennenkamp, M.D. Burke, J.J. Cartwright, J.D. Litster, Twin screw wet granulation: Influence of formulation parameters on granule properties and growth behavior, *Powder Technology*, 238 (2013) 108-115.
- [9] K.T. Lee, A. Ingram, N.A. Rowson, Twin screw wet granulation: The study of a continuous twin screw granulator using Positron Emission Particle Tracking (PEPT) technique, *European Journal of Pharmaceutics and Biopharmaceutics*, 81 (2012) 666-673.
- [10] J. Vercruyssen, M. Toiviainen, M. Fonteyne, N. Helkimo, J. Ketolainen, M. Juuti, U. Delaet, I. Van Assche, J.P. Remon, C. Vervaet, T. De Beer, Visualization and understanding of the granulation liquid mixing and distribution during continuous twin screw granulation using

NIR chemical imaging, *European journal of pharmaceutics and biopharmaceutics*, 86 (2014) 383-392.

[11] A. Kumar, J. Vercruyssen, M. Toivainen, P.E. Panouillot, M. Juuti, V. Vanhoorne, C. Vervaet, J.P. Remon, K.V. Gernaey, T. De Beer, I. Nopens, Mixing and transport during pharmaceutical twin-screw wet granulation: Experimental analysis via chemical imaging, *European journal of pharmaceutics and biopharmaceutics*, (2014) doi: 10.1016/j.ejpb.2014.04.004.

[12] H. Berthiaux, K. Marikh, C. Gatumel, Continuous mixing of powder mixtures with pharmaceutical process constraints, *Chemical Engineering Processing*, 47 (2008) 2315-2322.

[13] L. Pernenkil, T.P. Chirkot, C.L. Cooney, Continuous operation of Zigzag blender for pharmaceutical applications, in: *Proceedings of the Fifth World Congress on Particle Technology*, Orlando, Florida (USA) (2006).

[14] P.M. Portillo, M.G. Ierapetritou, F.J. Muzzio, Characterization of continuous convective powder mixing processes, *Powder Technology*, 182 (2008) 368-378.

[15] P. Porion, N. Sommier, A.M. Faugere, P. Evesque, Dynamics of size segregation and mixing of granular materials in a 3D-blender by NMR imaging investigation, *Powder Technology*, 141 (2004) 55-68.

[16] P.V. Danckwerts, Continuous flow systems. Distribution of residence times, *Chemical Engineering Science*, 50 (1953) 1-13.

[17] A.U. Vanarase, M. Jarvinen, J. Paaso, F.J. Muzzio, Development of a methodology to estimate error in the on-line measurements of blend uniformity in a continuous powder mixing process, *Powder Technology*, 241 (2013) 263-271.



## GENERAL CONCLUSIONS AND FUTURE PERSPECTIVES

---

This research project evaluated the opportunities offered by continuous wet granulation using the ConsiGma<sup>TM</sup> system (marketed by GEA Pharma Systems). Several aspects of this innovative technology were studied.

The quality of granules and tablets from a theophylline (30%) formulation could be optimized by adjusting specific process variables (i.e. number of kneading elements, barrel temperature and binder addition method). Furthermore, it was detected that increased throughput and number of kneading elements resulted in higher torque values during granulation.

NIR chemical imaging was used to evaluate the influence of several variables (liquid addition method, screw configuration, moisture content and barrel filling degree) on the moisture homogeneity of granules. The moisture homogeneity could only be drastically improved when the number of kneading zones on the granulator screws and the moisture content were increased. Although acceptable moisture uniformity could be achieved, particle size distribution results showed wide and bimodal profiles, indicating that the typical bi- or multimodal particle size distribution for granules produced by twin screw granulation is not linked to the insufficient mixing of powder and liquid phase during the short residence time of material inside the barrel, but rather to the granulation mechanism inherent to this technique.

The impact of the granulator screw configuration on the particle size distribution of granules produced by twin screw granulation was described. By combining conventional screw elements used for twin screw granulation (i.e. conveying and kneading elements) with screw mixing elements, granules with a more appropriate particle size distribution for tableting could be produced. Furthermore, because of their conveying capacity, stable torque profiles were detected for screw mixing elements.

The ConsiGma<sup>TM</sup> system proved to be useful for formulation and process development as the quality attributes of granules (and tablets) processed in a single cell of the segmented dryer unit were predictive of the steady state phase during full-scale manufacturing.

Furthermore, tablet quality obtained using granules processed with the ConsiGma™-1 system (laboratory unit) was predictive of tablet quality obtained during continuous production using the ConsiGma™-25 system.

A successful process transfer of a commercially available product from a batch fluid bed granulation and drying process to a continuous twin screw granulation and fluid bed drying process was demonstrated. Furthermore, by performing three consecutive 5h runs, the ConsiGma™-25 system was proven to be a stable and repeatable system for the continuous production of tablets via wet granulation.

Feeding API and excipient separately to a twin screw granulator was a valid alternative to preblending of all constituents of the formulation prior to twin screw granulation. However, due to the very short residence time and narrow residence time distribution inside a twin screw granulator, axial mixing is rather limited and attention should be paid to the performance of feeders as input variability is crucial.

Overall, this research project provided important process knowledge about the ConsiGma system as an innovative manufacturing tool for continuous production of solid dosage forms. Nevertheless, an extension of this project is essential to further extend process knowledge. Below, a few topics are identified for further investigation:

- Whereas the granulation mechanism for conventional batch granulation techniques have already been established, the fundamentals of agglomerate formation during the short residence time of the material inside the granulation unit need to be elucidated to get a better understanding of the process. This information, in combination with the knowledge about the effect of the different process and formulation variables, would allow to efficiently design a continuous granulation process based on the characteristics of the formulation and the requirements of the end product.
- Although the amount of material processed can be increased by prolonging the process run time, this does not entirely eliminate the need for continuous granulators of different sizes as each continuous granulator has a maximum throughput capacity. For certain applications this might result in a too long process

time to be economically feasible. Therefore, different ConsiGma units are available (ConsiGma 25, 50, 100 and 200 with a nominal throughput of 25, 50, 100 and 200 kg/h, respectively) to accommodate for increasing output. Using selected formulations the effect of the dimensions of the granulation and drying unit on the granule and tablet quality should be evaluated.

- As the processing of low-dosed drugs provides an important challenge during the manufacturing of solid dosage forms, the ability of the ConsiGma system to process highly potent API has to be investigated. Hereby, the addition method of the API (dry addition, liquid addition via granulation liquid as a suspension or solution) can be varied. The distribution of the API during the different stages of the process should be monitored (e.g. risk of intragranular migration of API during drying + associated risk of API loss due to granule attrition).
- As the efficiency of melt granulation in a conventional batch granulator (e.g. high-shear mixer) is limited due to uncontrolled agglomeration during cooling, continuous melt granulation using the granulation unit of the ConsiGma system should be assessed. However, as the residence time of the material inside the granulator is limited to a few seconds, an efficient heat transfer is required to ensure sufficient melting of the (lipophilic or hydrophilic) binder to ensure particle agglomeration.
- Accuracy of feeding of raw materials to the twin screw granulator is crucial. However, as the properties of the raw materials will affect the interactions between the feeding screws and the materials, these can induce variation in feeding rate, even under strict loss-in-weight control. At high feeding rate the discrete nature of the powder stream becomes less significant and feeding accuracy is enhanced. The main challenge is accurate feeding at low throughput since at this setting the variations can become highly significant compared to the feed rate.
- A fully continuous manufacturing process requires continuous monitoring of critical process parameters as well as continuous inspection of quality attributes of raw materials, intermediates and end product via at-line, on-line or in-line measurements by process analytical tools (e.g. NIR and Raman probes). However, there is a need for

adequate interfacing of the PAT tools. Hereby, an interfacing device must ensure that the probe does not interfere with the process or the product stream. Furthermore, fouling of the probes over process time should be avoided. Incorporation of in-process monitoring will ultimately allow real-time parametric release of the manufactured goods. However, approaches to perform in-line tests such as friability, disintegration, and dissolution still need to be developed.

- Mechanistic modelling based on the fundamental understanding of the underlying physics and chemistry is increasingly important due to the ongoing transition from batch to continuous production processes and its accompanied need for improved process understanding. Mathematical models facilitate process optimization and the development of control strategies, and should therefore be generated and validated for the different units of the ConsiGma system.
- Real-time-release requires that the process is not only monitored, but also controlled. Therefore, the process knowledge gathered in this project should be used to develop and implement an adequate process control strategy. Here, it is important to distinguish between feedforward control (i.e. changes are made in response to measurements of disturbances) and from feedback control (i.e. changes are made in response to measurements of variables that need to be controlled, such as content uniformity). A continuous process can be controlled in a truly dynamic fashion whereby downstream process parameters can be manipulated in response to measured upstream disturbances to maintain final product quality. Using both feedforward and feedback control in response to measurements of disturbances throughout the process represents a valuable advantage to the continuous process.
- Unit operations are typically designed as autonomous systems equipped with their own local controls. Such local control is sufficient in batch processing, as the unit operations are disconnected and do not need information from each other in order to function properly. While local control is also essential in continuous processing, the integration of unit operations requires global coordination of the entire process flow. Consequently, continuous systems have to be equipped with a second level software control system that supervises and aligns the work of the individual unit

operations. Furthermore, the software and hardware system should provide a high degree of automation, requiring minimal operator involvement.

- For any specific quantity of product produced from a continuous processing system and released to the market, it must be possible to reliably link the relevant process information to the specific quantity of product in a timely manner and to identify the origin of raw materials from which it has been manufactured. However, the tracking of product through the process becomes more complicated once multiple unit operations with different system dynamics become connected. Therefore, residence time distributions through the different unit operations and system dynamics should be fully elaborated. In addition to understanding each unit operation's transfer function, care must be taken to understand the delay times associated with material transport between unit operations. For example, planned disturbances such as feeder refills and how those disturbances propagate through the system should be understood. Furthermore, the disposition strategy of product obtained when the process is not in a state of control (e.g. start up, shut down, and process disturbances) should also be established.
- The conventional process validation approach (e.g. 3-batch validation at set-point) should be replaced by a design space approach, supported by Quality by Design. Hereby, the design space is a multidimensional combination and interaction of input variables (i.e. material attributes) and process parameters, within which acceptable product quality is obtained. Again, suitable PAT tools are essential to control the design space of a continuous process.

It is clear that for a successful implementation of this technology, the joint efforts of industry, academia, regulatory authorities and equipment vendors are needed. Given the tremendous benefits of continuous manufacturing, why has it not become the industry standard? The main reason is a "business as usual" approach embraced by a highly conservative industry. Specifically, it has been seen that new manufacturing approaches must be proven both technologically and financially superior, before widespread adoption will take place.

The good news is that things are starting to change. Some regulatory agencies are driving the industry towards continuous manufacturing and are working to break down both real and perceived regulatory obstacles. As management is becoming better aware of the benefits of continuous manufacturing, investments are made to move from batch to continuous. The question is not whether or not the industry should adopt continuous manufacturing, but how and when it will do so.

Twin screw granulation as a technique for continuous granulation of pharmaceuticals was originally developed at the Laboratory of Pharmaceutical Technology (Ghent University). Based on this research work, GEA Pharma Systems elaborated the ConsiGma™ system, a 'from-powder-to-tablet' manufacturing line for solid dosage forms using twin screw granulation as an intermediate wet granulation step. This research project aimed at increasing the process knowledge of the ConsiGma system towards pharmaceutical formulations. Therefore, several aspects of this innovative technology were evaluated.

**The introduction** illustrates the increasing interest of the pharmaceutical industry for continuous manufacturing. The conventional batch-wise production approach was compared with the concept of continuous processing. The multiple benefits related to continuous manufacturing were described. Barriers for implementation based on regulatory, cultural (inertia to change within conservative pharma business), educational (operators are trained for batch processes) as well as technical issues (batch equipment is widely available, continuous technologies are not sufficiently proven or are not available for specific applications) were explained. Several examples of technologies that could be integrated into a continuous manufacturing line for tablets were given. Furthermore, the more recently developed fully integrated continuous manufacturing lines for solid dosage forms were elaborated. Finally, the vital importance of PAT and process control systems for real-time release of manufactured goods was emphasized.

**Chapter 1** reports the screening of theophylline (125 mg) tablets manufactured via twin screw granulation in order to improve process understanding and knowledge of process variables that determine granule and tablet quality. A premix of theophylline anhydrate,  $\alpha$ -lactose monohydrate and PVP (ratio: 30/67.5/2.5, w/w) was granulated with demineralized water. Using a D-optimal experimental design, the effect of several process variables (throughput (10-25 kg/h), screw speed (600-950 rpm), screw configuration (number (2, 4, 6 and 12) and angle (30, 60 and 90 degrees) of kneading elements), barrel temperature (25-40 °C) and method of binder addition (dry versus wet)) on the granulation process (torque and temperature increase in barrel wall), granule (particle size distribution (PSD), friability and

flowability) and tablet (tensile strength, porosity, friability, disintegration time and dissolution) quality was evaluated. No significant relationships for angle of kneading elements and screw speed were found. Increased throughput and number of kneading elements resulted in higher torque values during granulation. More friction due to elongation of the kneading zone resulted in a higher temperature increase of the barrel wall. A higher number of kneading elements and barrel temperature resulted in less fines, more oversized agglomerates and less friable granules. As barrel temperature had an important effect on the granule properties, this parameter should be carefully controlled, especially when using good water-soluble components, for example lactose. Because of the short residence time during twin screw granulation, the binder was more effective when it was already dissolved in the granulation liquid. The tensile strength, disintegration time and dissolution profile of tablets depended on the number of kneading elements. Increasing the number of kneading elements yielded denser granules that were less deformable during compression. Percolation of liquids inside these granules is hampered, resulting in tablets with a longer disintegration time and a slower drug release. The results showed that the quality of granules and tablets can be optimized by adjusting specific process variables (number of kneading elements, barrel temperature and binder addition method) during a granulation process using a continuous twin screw granulator.

The mixing of granulation liquid and powder material during the short residence time inside the screw chamber and the atypical PSD of granules produced by twin screw granulation is not yet fully understood. Therefore, in **Chapter 2** the granulation liquid mixing and distribution during continuous twin screw granulation was visualized using NIR chemical imaging. In first instance, the residence time of material inside the barrel was investigated as function of screw speed and moisture content followed by the visualization of the granulation liquid distribution as function of different formulation and process parameters (liquid feed rate, liquid addition method, screw configuration, moisture content and barrel filling degree). The link between moisture uniformity and granule size distribution was also studied. For residence time analysis, a higher screw speed and lower moisture content resulted in a shorter mean residence time and narrower residence time distribution. Changing the liquid addition method (pump orientation (in-phase vs. out-of-phase), pump type (peristaltic vs. piston pump), tubing configuration (independent vs. split tubing), nozzle



diameters (0.8, 1.6 and 2.4 mm) and liquid addition zones (1 vs. 2 zones)) or the barrel filling degree did not have an impact on the mixing efficiency of powder and liquid phase. The distribution of granulation liquid was more homogenous at higher moisture content and when more kneading zones were incorporated in the granulator screws. After optimization of the screw configuration, a two-level full factorial experimental design was performed to evaluate the influence of moisture content, screw speed and powder feed rate on the mixing efficiency of the powder and liquid phase. From these results, it was concluded that only increasing the moisture content significantly improved the granulation liquid distribution. Although moisture uniformity could be achieved with more kneading zones and at a higher liquid feed rate, PSD results showed broad and bimodal profiles, indicating that the typical bimodal PSD for granules produced by twin screw granulation is not mainly caused by the insufficient mixing of powder and liquid phase during the short residence time of material inside the barrel but rather inherent to the granulation mechanism of this technique. This study demonstrated that NIR chemical imaging is a fast and adequate measurement tool for process visualization and hence for providing better process understanding of a continuous twin screw granulation system. Although NIR chemical imaging is not readily applicable for in-line monitoring of a continuous granulation process, it can be considered as an indispensable research tool during process development and optimization.

**Chapter 3** evaluates the impact of the granulator screw configuration in a twin screw granulator on the PSD of granules. Granulation with conveying elements resulted in a broad and multimodal PSD. Using kneading elements, the width of the PSD could be partially narrowed, which was also correlated with a more homogeneous liquid distribution. However, still a significant fraction of oversized agglomerates was detected. Implementing additional kneading elements or cutters at the screw end was not beneficial. Furthermore, granulation with only tooth-mixing-elements or screw mixing elements could not drastically decrease the width of the PSD. However, the process yield could be improved by combining kneading elements with screw mixing elements. For these screw configurations, the PSD was narrower and shifted to the size fractions suitable for tableting. Furthermore, because of their conveying capacity, stable torque profiles were detected for screw mixing elements.

Since small scale is key for successful introduction of continuous techniques in the pharmaceutical industry (i.e. to allow its use during formulation development and process

optimization), it is essential to determine if the product quality is similar when small quantities of materials are processed compared to the continuous processing of larger quantities. Therefore, **Chapter 4** explored whether material processed in a single cell of the six-segmented fluid bed dryer of the ConsiGma™-25 system is predictive of granule and tablet quality during full-scale manufacturing (i.e. when all drying cells are filled). Furthermore, the performance of the ConsiGma™-1 system (a mobile laboratory unit) was evaluated and compared to the ConsiGma™-25 system. By performing a 1h continuous run, it was detected that a stabilization period was needed for the torque and the temperature of the barrel wall due to initial layering of the screws and the screw chamber walls with material. Consequently, slightly deviating granule and tablet quality attributes were obtained during the first 30 min of the 1h run. However, as for the single cell runs the initial layering was already accomplished in advance, granule and tablet properties were comparable to results obtained during the second half of the 1h run (after start-up). No deviating granule and tablet quality was observed during the shutdown phase of the continuous run. Hence, this study showed that processing of material in a single cell of the segmented dryer unit of the ConsiGma™-25 system was repeatable and that the quality attributes of granules (residual moisture content, PSD, bulk and tapped density, Hausner ratio, friability) and tablets (hardness, friability, disintegration time and dissolution) processed in a single cell were predictive for the steady state phase during full-scale manufacturing. Although deviating granule quality (PSD and Hausner ratio) was observed due to the divergent design of the ConsiGma™-1 unit and the ConsiGma™-25 system (horizontal set-up) used in this study, tablet quality produced from granules processed with the ConsiGma™-1 system was predictive for tablet quality obtained during continuous production using the ConsiGma™-25 system.

**Chapter 5** focused on the process transfer of a commercially available product from a batch fluid bed granulation and drying process to a continuous twin screw granulation and fluid bed drying process. By monitoring process outcomes (torque, water temperature at the granulator jacket inlet, differential pressure over the dryer filters, and temperature mill screen) and granule and tablet quality in function of process time, the stability and repeatability during long production runs were determined. For each of the investigated process outcomes, a stabilization period was needed to reach steady-state conditions.

However, the granules and tablets produced during start-up were in compliance with the specifications. During three consecutive 5 h continuous production runs, granule and tablet quality was constant in function of time. Although PSD and Hausner ratio values of milled granules were found to be different for granules produced by the twin screw granulation process compared to the batch fluid bed granulation process, results for critical tablet quality attributes were in compliance with the specifications defined for the batch process. Consequently, from this study, the ConsiGma™-25 system can be considered as a stable and repeatable system for the continuous production of tablets via wet granulation.

For twin screw granulation processes, typically a preblend of raw materials is fed to the inlet of the twin screw granulator followed by addition of granulation liquid. However, a truly continuous process uses several feeders (each one dosing an individual ingredient) and relies on the mixing capacity of the screws in the granulation unit to homogenize the formulation. In **Chapter 6**, the performance of a twin screw granulator as a continuous blender for the preparation of binary powder mixtures was studied. The formulation consisted of theophylline as the active pharmaceutical ingredient (API) and lactose as the excipient. Both materials were individually fed into the screw chamber via two separate powder feed ports. Blender performance, characterized by the relative standard deviation (RSD) on theophylline content of samples taken at the blender discharge and by the variance reduction ratio (VRR) of the TSG, was measured as a function of throughput, screw speed and drug load. Furthermore, the influence of particle size of raw materials, screw configuration, addition order of materials and addition of granulation liquid on the blend homogeneity was investigated. It was observed that the drug load highly influenced the blend homogeneity at the discharge as it was more difficult to acquire stable feeding and homogenous distribution of low-dosed components: the lower the drug load, the higher the RSD values. Varying the throughput and screw speed did not affect RSD at the discharge. The addition of kneading elements improved the blending capacity. Decreasing the particle size of the excipient did not have a negative effect on mixing performance because of high shear and de-agglomeration inside the twin screw granulator. Blend homogeneity was better if API was added into the screw chamber before the excipient. Addition of granulation liquid increased axial mixing and improved the blending performance. This study showed that feeding API and excipient separately to a twin screw granulator can be a valid alternative to preblending

of all constituents of the formulation prior to twin screw granulation. However, due to the very short residence time and narrow residence time distribution inside a twin screw granulator, axial mixing is rather limited. Therefore, attention should be paid to the performance of feeders as input variability is crucial.

Based on this research work, it can be concluded that the ConsiGma technology is a promising platform for the continuous production of pharmaceuticals.

Twin screw granulatie, een techniek die gebruikt wordt voor de continue granulatie van geneesmiddelen, werd oorspronkelijk ontwikkeld in het Laboratorium voor Farmaceutische Technologie (Universiteit Gent). Gebaseerd op dit onderzoekswerk, heeft GEA Pharma Systems het ConsiGma<sup>TM</sup> systeem, een productielijn voor de aanmaak van vaste doseringsvormen (van poeders tot tabletten) waarbij twin screw granulatie als tussenstap voor natte granulatie gebruikt wordt, ontwikkeld. Het doel van dit onderzoeksproject was het uitbreiden van de proceskennis van het ConsiGma systeem, specifiek voor de verwerking van farmaceutische formulaties. Hiertoe werden verschillende aspecten van deze innovatieve technologie geëvalueerd.

De **inleiding** illustreert de stijgende interesse van de farmaceutische industrie voor continue productie. De conventionele batchgewijze productie, waarbij lot per lot aangemaakt wordt, werd vergeleken met het concept van continue productie. De verschillende voordelen verbonden aan continue productie werden beschreven. Barrières voor de implementatie van continue productie die gebaseerd zijn op regulatoire, culturele (inertie aan verandering binnen de conservatieve farmaceutische industrie), opleidingsgerelateerde (operatoren werden voornamelijk opgeleid voor batchgewijze processen) alsook technische problemen (apparatuur voor batchgewijze processen zijn algemeen beschikbaar terwijl continue technieken nog niet voldoende bewezen werden of nog niet beschikbaar zijn voor specifieke toepassingen) werden toegelicht. Daarnaast werden verschillende voorbeelden van technologieën die geïntegreerd kunnen worden in een continue productielijn voor de aanmaak van tabletten beschreven. Bovendien werden de recent ontwikkelde volledige geïntegreerde continue productielijnen voor vaste doseringsvormen behandeld. Tot slot werd het vitaal belang van proces analytische technologie (PAT) en systemen voor procescontrole voor de real-time vrijstelling van geproduceerde goederen onderstreept.

In **hoofdstuk 1** werd de screening van tabletten met theophylline (125 mg), aangemaakt via twin screw granulatie, beschreven. Het doel hierbij was de proceskennis te vergroten en meer te weten te komen over de procesvariabelen die de kwaliteit van de granules en de tabletten bepalen. Een mengsel van theofylline anhydraat,  $\alpha$ -lactose monohydraat en PVP

(ratio: 30/67.5/2.5, w/w) werd met gedemineraliseerd water gegranuleerd. Gebruikmakend van een D-optimaal experimenteel design, werd het effect van verschillende procesvariabelen (toevoersnelheid van het poeder (10-25 kg/u), schroefsnellheid (600-950 tpm), schroefconfiguratie (aantal (2, 4, 6 en 12) en hoek (30, 60 en 90 graden) van de kneedelementen), temperatuur van de schroefkamer (25-40 °C) en de methode waarop de binder toegevoegd werd (droog versus nat)) op het granulatieproces (weerstand tegen rotatie van de schroeven en temperatuurstijging van de wand van de schroefkamer) en op de kwaliteit van de granules (deeltjesgroottedistributie, friabiliteit en vloeieigenschappen) en tabletten (tabletsterkte, porositeit, friabiliteit, desintegratietijd en dissolutie) geëvalueerd. De hoek van de kneedelementen en de schroefsnellheid vertoonden geen significante invloed. Een hogere toevoersnelheid van het poeder en een hoger aantal kneedelementen resulteerde in een hogere weerstand voor rotatie van de schroeven tijdens granulatie. Meer wrijving veroorzaakt door een verlenging van de kneedzone leidde tot een sterkere stijging van de temperatuur van de wand van de schroefkamer. Een hoger aantal kneedelementen en verhoogde temperatuur van de wand van de schroefkamer gaven aanleiding tot minder niet-geagglomereerd materiaal, een stijgend aantal te grote agglomeraten en granules met een lagere friabiliteit. Aangezien de temperatuur van de schroefkamer een belangrijke impact heeft op de eigenschappen van de granules, dient deze parameter zorgvuldig gecontroleerd te worden, in het bijzonder wanneer goed wateroplosbare componenten gebruikt worden, bijvoorbeeld lactose. Door de korte verblijftijd van het materiaal tijdens twin screw granulatie, was het bindmiddel efficiënter indien dit vooraf opgelost werd in de granulatievloeistof. De tabletsterkte, desintegratietijd en het dissolutieprofiel van de tabletten was afhankelijk van het aantal kneedelementen. Een hoger aantal kneedelementen gaf aanleiding tot dichtere granules die minder vervormbaar waren tijdens het tableteren. Percolatie van vloeistoffen in deze granules wordt hierdoor gehinderd, waardoor tabletten een langere desintegratietijd en een tragere vrijstelling van het geneesmiddel vertonen. De resultaten van deze studie tonen aan dat het mogelijk is om de kwaliteit van granules en tabletten te optimaliseren via aanpassing van specifieke procesvariabelen (aantal kneedelementen, temperatuur van de schroefkamer en de methode van binderadditie) tijdens een granulatieproces waarbij gebruik gemaakt wordt van continue twin screw granulatie.

Het inmengen van granulatievloeistof en poeders tijdens de korte verblijftijd in de schroefkamer en de atypische deeltjesgroottedistributie van granules die geproduceerd worden via twin screw granulatie is tot nu toe nog niet volledig doorgrond. Daarom werd in **hoofdstuk 2** het inmengen en de distributie van de granulatievloeistof tijdens het continue twin screw granulatieproces gevisualiseerd via NIR chemische beeldvorming. In eerste instantie werd de verblijftijd van het materiaal in de schroefkamer in functie van de schroefsnelheid en het vochtgehalte bestudeerd, gevolgd door de visualisatie van de distributie van de granulatievloeistof in functie van verschillende formulatie- en procesparameters (toevoersnelheid van de granulatievloeistof, methode van vloeistoftoevoeging, schroefconfiguratie, vochtgehalte en vullingsgraad van de schroefkamer). Bovendien werd de link tussen de verdeling van de granulatievloeistof en de deeltjesgroottedistributie van de granules onderzocht. Bij de analyse van de verblijftijd werd gezien dat een hogere schroefsnelheid en een lager vochtgehalte in een kortere gemiddelde verblijftijd en een nauwere distributie van de verblijftijd resulteerde. Het veranderen van de methode waarop de vloeistof toegevoegd werd (oriëntatie van de pomp (in fase of uit fase), type pomp (peristaltisch of pistonpomp), configuratie van de leidingen (onafhankelijk of gesplitst), diameter van de nozzles (0.8, 1.6 of 2.4 mm) en het aantal zones voor vloeistoftoevoeging (1 of 2 zones)) of de vullingsgraad van de schroefkamer hadden geen invloed op de mengefficiëntie van het poeder en de granulatievloeistof. Echter, een homogener verdeling van de granulatievloeistof werd bekomen indien het vochtgehalte hoger was en wanneer meer kneedzones op de schroeven geplaatst werden. Na optimalisatie van de schroefconfiguratie, werd een volledig factorieel design op 2 niveaus uitgevoerd om de invloed van het vochtgehalte, de schroefsnelheid en de toevoersnelheid van het poeder op de mengefficiëntie van het poeder en de granulatievloeistof na te gaan. Hieruit bleek dat enkel door het verhogen van het vochtgehalte de verdeling van de granulatievloeistof significant verbeterd kon worden. Hoewel een homogener verdeling van de granulatievloeistof bekomen kon worden indien meerdere kneedzones geïmplementeerd werden en het vochtgehalte hoog was, vertoonde de deeltjesgroottedistributie brede en bimodale profielen. Dit wijst erop dat de bimodale deeltjesgroottedistributies, die typisch bekomen worden voor granules aangemaakt via twin screw granulatie, niet veroorzaakt worden door een onvoldoende inmenging van de granulatievloeistof doorheen het poederbed gedurende de korte verblijftijd van het materiaal in de schroefkamer maar

eerder inherent is aan het granulatiemechanisme van deze techniek. Deze studie toonde aan dat NIR chemische beeldvorming een snelle en geschikte techniek is om het proces in beeld te brengen en hierdoor bijdraagt tot het beter begrijpen van het continu twin screw granulatieproces. Hoewel NIR chemische beeldvorming niet direct toepasbaar is voor de in-line monitoring van een continu granulatieproces, kan het beschouwd worden als een onmisbare techniek voor procesontwikkeling en optimalisatie.

In **hoofdstuk 3** werd de invloed van de schroefconfiguratie op de deeltjesgroottedistributie van granules aangemaakt via twin screw granulatie geëvalueerd. Het gebruik van enkel transportelementen resulteerde in een brede en multimodale deeltjesgroottedistributie. Indien kneedelementen gebruikt werden, kon de deeltjesgroottedistributie gedeeltelijk vernauwd worden, wat ook gecorreleerd was met een homogener vloeistofverdeling. Hoe dan ook werd hierbij nog steeds een significante fractie van te grote agglomeraten gedetecteerd. Implementatie van extra kneedelementen of hakelementen op het einde van de schroeven was niet bevorderlijk. Verder gaf het gebruik van enkel getande elementen of mengelementen geen aanleiding tot een nauwere deeltjesgroottedistributie. De opbrengst van het proces kon echter wel verhoogd worden door kneedelementen te combineren met mengelementen. Voor deze schroefconfiguraties werd een nauwere deeltjesgroottedistributie bekomen. Bijkomend werden door een verlaging van de gemiddelde deeltjesgrootte granules bekomen die meer geschikt zijn om in een volgende stap te tableteren. Bovendien werd bij gebruik van deze elementen, omwille van hun transporterend vermogen, stabiele waarden voor de weerstand tegen rotatie van de schroeven bekomen.

Aangezien de mogelijkheid van het gebruik van continue technieken op kleine schaal cruciaal is voor de succesvolle introductie van continue technieken in de farmaceutische industrie (d.i. voor het gebruik tijdens formulatie-ontwikkeling en procesoptimalisatie), is het essentieel om na te gaan of de productkwaliteit overeenstemt indien kleine hoeveelheden materiaal aangemaakt worden ten opzichte van de continue aanmaak van grotere hoeveelheden. Daarom werd in **hoofdstuk 4** nagegaan of materiaal dat verwerkt werd in één enkele cel van de gesegmenteerde wervelbeddroger van het ConsiGma<sup>TM</sup>-25 systeem predictief is voor de granule- en tabletkwaliteit gedurende productie op grote schaal (d.i. wanneer alle droogcellen gevuld zijn). Bovendien werd het gebruik van het ConsiGma<sup>TM</sup>-1



systeem (een mobiele eenheid voor gebruik in laboratoria) geëvalueerd en vergeleken met het ConsiGma<sup>TM</sup>-25 systeem. Door het uitvoeren van een 1 uur durende continue run, werd gezien dat er een stabilisatieperiode was voor de weerstand tegen rotatie van de schroeven en de temperatuur van de wand van de schroefkamer. Dit werd veroorzaakt door de initiële vorming van een materiaallaag op de schroeven en de wand van de schroefkamer. Hierdoor werd een licht afwijkende granule- en tablet kwaliteit bekomen tijdens de eerste 30 min van de 1 uur durende run. Aangezien voor de runs waarbij slechts 1 droogcel gevuld werd de materiaallaag reeds vooraf werd aangebracht, werd hierbij een vergelijkbare granule- en tablet kwaliteit bekomen als gedurende de tweede helft van de 1 uur durende run (d.i. na de opstartfase). Verder werd geen afwijkende granule- en tablet kwaliteit tijdens het beëindigen van de continue run bekomen. Deze studie toonde aan dat het verwerken van materiaal in uitsluitend 1 droogcel van de gesegmenteerde droger van het ConsiGma<sup>TM</sup>-25 systeem herhaalbaar was en dat de kwaliteit van granules (residueel vochtgehalte, deeltjesgroottedistributie, stort- en schuddichtheid, Hausner ratio, friabiliteit) en tabletten (hardheid, friabiliteit, disintegratietijd en dissolutie) die verwerkt werden in uitsluitend 1 droogcel predictief is voor de kwaliteit bekomen tijdens productie op grote schaal. Hoewel, omwille van de uiteenlopende configuratie, afwijkende granule kwaliteit (deeltjesgrootte en Hausner ratio) bekomen werd via het ConsiGma<sup>TM</sup>-1 systeem (verticale opstelling) ten opzichte van het ConsiGma<sup>TM</sup>-25 systeem (horizontale opstelling), was de tablet kwaliteit bekomen via het ConsiGma<sup>TM</sup>-1 systeem predictief voor deze tijdens continue productie gebruikmakend van het ConsiGma<sup>TM</sup>-25 systeem.

In **hoofdstuk 5** werd de procestransfer van een commercieel beschikbaar product van een batchgewijs wervelbedgranulatie- en droogproces naar een continu twin screw granulatie- en wervelbeddroogproces beschreven. Door controle van verschillende procesgerelateerde parameters (weerstand tegen rotatie van de schroeven, temperatuur van het inkomend water van de mantel rondom de schroefkamer, drukverschil over de filters in de droger en de temperatuur van de zeef in de molen) en de granule- en tablet kwaliteit in functie van de procestijd, werd de stabiliteit en herhaalbaarheid van het ConsiGma systeem tijdens lange productieruns bepaald. Voor elk van deze parameters werd een bepaalde stabilisatieperiode gedetecteerd vooraleer een constante waarde bereikt werd. Echter, de granules en tabletten bekomen tijdens deze opstartfase waren in overeenstemming met de

vooropgestelde eisen. Gedurende drie opeenvolgende 5 uur durende productieruns was de granule- en tablet kwaliteit constant in functie van de procestijd. Hoewel de deeltjesgroottedistributie en de Hausner ratio van de gemalen granules aangemaakt via twin screw granulatie en via batchgewijze wervelbedgranulatie verschilden, stemde de kwaliteit van de tabletten aangemaakt via het continu proces overeen met de specificaties die opgesteld waren voor het batchgewijze proces. Bijgevolg kan het ConsiGma™-25 systeem beschouwd worden als een stabiel en herhaalbaar systeem voor de continue productie van tabletten via natte granulatie.

Bij twin screw granulatie wordt veelal een vooraf gemaakt mengsel van de startmaterialen naar de ingang van de twin screw granulator gevoed, gevolgd door toevoeging van de granulatievloeistof. Echter, bij een volledig continu proces dient gebruik gemaakt te worden van verschillende voeders (waarbij elke voeder een individueel ingrediënt aanbrengt) en dient gesteund te worden op de mengcapaciteit van de schroeven in de granulator om de verschillende stoffen te homogeniseren. Daarom werd in **hoofdstuk 6** de mogelijkheid tot het gebruik van een twin screw granulator als een continue blender voor de aanmaak van binaire poedermengsels bestudeerd. De formulatie die gebruikt werd in deze studie was samengesteld uit theofylline als actief farmaceutisch ingrediënt en lactose als hulpstof. Beide poeders werden individueel gevoed naar de schroefkamer via twee afzonderlijke poorten. De mengcapaciteit, weergegeven door de relatieve standaarddeviatie (RSD) van het gehalte theofylline in de stalen genomen aan de uitgang van de schroefkamer en de variantie reductie ratio (VRR) van de twin screw granulator, werden bepaald in functie van de toevoersnelheid van het poeder, de schroefsnelheid en de geneesmiddelbelading. Bovendien werd de invloed van de deeltjesgrootte van de startmaterialen, de schroefconfiguratie, de volgorde van toevoeging van de materialen en de toevoeging van granulatievloeistof op de homogeniteit van het poedermengsel onderzocht. Hierbij werd gezien dat de geneesmiddelbelading een sterke invloed had op de homogeniteit van het poedermengsel ter hoogte van de uitgang van de schroefkamer. Het is immers moeilijker om een stabiele toevoersnelheid en homogene distributie van een laaggedoseerde component te bekomen: hoe lager de geneesmiddelbelading, hoe hoger de RSD waarden zowel aan de ingang als aan de uitgang van de schroefkamer. Verandering van de totale toevoersnelheid van de poeders en schroefsnelheid hadden geen effect op de RSD waarden ter hoogte van

de uitgang van de schroefkamer. Implementatie van meer kneedelementen op de schroeven gaf aanleiding tot een hogere mengcapaciteit. Verkleinen van de deeltjesgrootte van de hulpstof had geen negatieve invloed op de mengcapaciteit omwille van de hoge shear en opbraak van poederaggregaten in de twin screw granulator. De homogeniteit van de blend was beter indien het actief farmaceutisch ingrediënt op een eerdere positie gevoed werd naar de schroefkamer ten opzichte van de hulpstof. Toevoeging van granulatievloeistof verhoogde de axiale menging en verbeterde de mengcapaciteit. Deze studie toonde aan dat, bij twin screw granulatie, het apart voeden van de componenten van een formulatie naar de schroefkamer een waardig alternatief vormt voor het vooraf mengen van alle ingrediënten van een formulatie. Echter, omwille van de korte verblijftijd en nauwe distributie van de verblijftijd in een twin screw granulator, is de axiale menging beperkt. Daarom dient voldoende aandacht geschonken te worden aan de werking van de voeders aangezien dit cruciaal is voor de variabiliteit aan de ingang van de twin screw granulator.

Gebaseerd op dit onderzoekswerk, kan besloten worden dat de ConsiGma technologie een veelbelovend platform is voor de continue productie van geneesmiddelen.



# CURRICULUM VITAE

---

## PERSONAL INFORMATION

Name: VERCRUYSSSE Jurgen  
Date of birth: November 17<sup>th</sup>, 1985  
Place of birth: Roeselare, Belgium  
Civil status: Married with Sofie Dewaele  
Private Address: Vennestraat 14, 9870 Zulte  
Professional Address: Ghent University  
Faculty of Pharmaceutical Sciences  
Laboratory of Pharmaceutical Technology  
Ottergemsesteenweg 460  
9000 Ghent  
Phone: +32(0)92648039  
Mobile: +32(0)473459058  
Jurgen.Vercruysse@Ugent.be

## LANGUAGE SKILLS

Dutch (native language)  
English  
French  
(German)

## EDUCATION

### University

2009 – present: PhD candidate in Pharmaceutical Technology  
Laboratory of Pharmaceutical Technology, Ghent University  
Scientific promoter: Prof. dr. C. Vervaet  
Industrial promoter: dr. I. Van Assche (Janssen Pharmaceutica)

- 2008 – 2009: Master after Master of Industrial Pharmacy  
Inter-university programme (UGent, KUL, UA, VUB)  
Graduated with great distinction
- 2003 – 2008: Master of Pharmaceutical Sciences  
Ghent University  
Graduated with great distinction

Secondary school

- 1997 – 2003: Latin – Mathematics  
Sint-Jan Berchmanscollege Avelgem

**RESEARCH EXPERIENCE**

- 2009 – present: PhD research: “Innovation in pharmaceutical manufacturing of solid dosage forms via continuous wet granulation”  
Laboratory of Pharmaceutical Technology, Ghent University  
Scientific promoter: Prof. dr. C. Vervaet  
Industrial promoter: dr. I. Van Assche (Janssen Pharmaceutica)
- Sep 2008 – Jan 2009: Master after Master thesis: “Development of sustained-release multiple unit dosage forms via hot-stage extrusion”  
Laboratory of Pharmaceutical Technology, Ghent University  
Promoter: Prof. dr. J.P. Remon  
Co-promoter: Prof. dr. C. Vervaet
- Feb – Jun 2007: Master thesis: “Bioresponsive dextran microgels for the controlled release of small interfering RNA”  
Laboratory of General Biochemistry and Physical Pharmacy, Ghent University  
Promoter: Prof. dr. S. De Smedt

**WORK EXPERIENCE**

- 2010 – 2014: Tutor and Lab instructor Pharmaceutical Bachelor Proof  
Ghent University
- 2009 – 2014: Teaching assistant practical courses: “Artsenijbereidkunde” (3<sup>rd</sup>)

bachelor of Pharmaceutical Sciences) and “Farmaceutische Technologie” (2<sup>nd</sup> master of Pharmaceutical Sciences)

Jul – Aug 2008: Pharmacist  
Apotheek Verhoest – Vervaet, Harelbeke

Jul 2007 – May 2008: Pharmacist (internship)  
Apotheek Verhoest – Vervaet, Harelbeke

## INTERNATIONAL PUBLICATIONS

- Study on the influence of granulation process parameters on tablet properties using transmission and backscattering Raman and transmission NIR.  
E. Peeters, A.F.T. Silva, M. Toiviainen, M. Juuti, J. Van Renterghem, M. Fonteyne, **J. Vercruyse**, T. De Beer, C. Vervaet, J.P. Remon.  
In preparation
- Conceptual framework for model-based analysis of residence time distribution in twin screw granulation.  
A. Kumar, **J. Vercruyse**, V. Vanhoorne, M. Toiviainen, P.E. Panouillot, M. Juuti, K.V. Gernaey, T. De Beer, I. Nopens.  
In preparation
- Statistical process monitoring of a continuous pharmaceutical twin screw granulation and drying process.  
A.F.T. Silva, **J. Vercruyse**, U. Delaet, I. Van Assche, P. Cappuyens, F. Arata, G. Caporicci, J.L.F.C. Lima, J.A. Lopes, C. Vervaet, J.P. Remon, T. De Beer  
In preparation
- Process analytical techniques for the continuous manufacturing of solid dosage forms (review).  
M. Fonteyne, **J. Vercruyse**, F. De Leersnyder, B. Van Snick, C. Vervaet, J.P. Remon, T. De Beer.  
In preparation

- Impact of screw configuration on the particle size distribution of granules produced by twin screw granulation.  
**J. Vercruyse**, A. Burggraeve, M. Fonteyne, U. Delaet, I. Van Assche, P. Cappuyns, T. De Beer, J.P. Remon, C. Vervaet.  
Submitted to European Journal of Pharmaceutics and Biopharmaceutics
- Impact of microcrystalline cellulose material attributes: a case study on continuous twin screw granulation.  
M. Fonteyne, A. Correia, S. De Plecker, **J. Vercruyse**, I. Ilic, Q. Zhou, C. Vervaet, C. Vervaet, J.P. Remon, F. Onofre, V. Bulone, T. De Beer.  
Submitted to European Journal of Pharmaceutics and Biopharmaceutics
- Evaluation of powder blending in a twin screw granulator: an experimental approach.  
**J. Vercruyse**, M. Fonteyne, A. Kumar, U. Delaet, I. Van Assche, I. Nopens, T. De Beer, J.P. Remon, C. Vervaet.  
Submitted to International Journal of Pharmaceutics
- Use of a continuous twin screw granulation and drying system during formulation development and process optimization.  
**J. Vercruyse**, E. Peeters, M. Fonteyne, P. cappuyns, U. Delaet, I. Van Assche, T. De Beer, J.P. Remon, C. Vervaet.  
Submitted to European Journal of Pharmaceutics and Biopharmaceutics
- Experimental investigation of granule size and shape dynamics in twin screw granulation.  
A. Kumar, **J. Vercruyse**, G. Bellandi, K.V. Gernaey, C. Vervaet, J.P. Remon, T. De Beer, I. Nopens.  
Submitted to European Journal of Pharmaceutics and Biopharmaceutics
- Moisture and drug solid state monitoring during a continuous drying process using empirical and mass balance models.  
M. Fonteyne, D. Gildemyn, E. Peeters, S.T. Mortier, **J. Vercruyse**, K.V. Gernaey, C. Vervaet, J.P. Remon, I. Nopens, T. De Beer.  
European Journal of Pharmaceutics and Biopharmaceutics, 2014, 87 (3) 616-628.
- Visualization and understanding of the granulation liquid mixing and distribution during continuous twin screw granulation using NIR chemical imaging.



**J. Vercruyse**, M. Toiviainen, M. Fonteyne, N. Helkimo, J. Ketolainen, M. Juuti, U. Delaet, I. Van Assche, J.P. Remon, C. Vervaet, T. De Beer.

European Journal of Pharmaceutics and Biopharmaceutics, 2014, 86 (3) 383-392.

- Mixing and transport during pharmaceutical twin-screw wet granulation: experimental analysis via chemical imaging.

A. Kumar, **J. Vercruyse**, M. Toiviainen, P.E. Panouillot, M. Juuti, V. Vanhoorne, C. Vervaet, J.P. Remon, K.V. Gernaey, T. De Beer, I. Nopens.

European Journal of Pharmaceutics and Biopharmaceutics, 2014, 87 (2) 279-289.

- Influence of raw material properties upon critical quality attributes of continuously produced granules and tablets.

M. Fonteyne, H. Wickström, E. Peeters, **J. Vercruyse**, H. Ehlers, B.H. Peters, J.P. Remon, C. Vervaet, J. Ketolainen, N. Sandler, J. Rantanen, K. Naelapää, T. De Beer.

European Journal of Pharmaceutics and Biopharmaceutics, 2014, 87 (2) 252-263.

- Distribution of binder in granules produced by means of twin screw granulation.

M. Fonteyne, A.L. Fussell, **J. Vercruyse**, C. Vervaet, J.P. Remon, C. Strachan, T. Rades, T. De Beer.

European Journal of Pharmaceutics and Biopharmaceutics, 2014, 462 (1-2) 8-10.

- Stability and repeatability of a continuous twin screw granulation and drying system.

**J. Vercruyse**, U. Delaet, I. Van Assche, P. Cappuyns, F. Arata, G. Caporicci, T. De Beer, J.P. Remon, C. Vervaet.

European Journal of Pharmaceutics and Biopharmaceutics, 2013, 85 (3) 1031-1038.

- Continuous processing of pharmaceuticals.

C. Vervaet, **J. Vercruyse**, J.P. Remon, T. De Beer.

In Encyclopedia of Pharmaceutical Science and Technology, Fourth edition. Taylor and Francis: New York, published online: 23 Aug 2013, 644-655.

<http://dx.doi.org/10.1081/E-EPT4-120050224>

- Real-time assessment of critical quality attributes of a continuous granulation process.

M. Fonteyne, **J. Vercruyse**, D. Córdoba Díaz, D. Gildemyn, C. Vervaet, J.P. Remon, T. De Beer.

Pharmaceutical Development and Technology, 2013, 18 (1), 85-97.

- Prediction of quality attributes of continuously produced granules using complementary PAT tools.  
M. Fonteyne, S. Soares, **J. Vercruyse**, E. Peeters, A. Burggraeve, C. Vervaet, J.P. Remon, N. Sandler, T. De Beer.  
European Journal of Pharmaceutics and Biopharmaceutics, 2012, 82 (2), 429-436.
- Continuous twin screw granulation: influence of process variables on granule and tablet quality.  
**J. Vercruyse**, D. Córdoba Díaz, E. Peeters, M. Fonteyne, U. Delaet, I. Van Assche, T. De Beer, J.P. Remon, C. Vervaet.  
European Journal of Pharmaceutics and Biopharmaceutics, 2012, 82 (1), 205-11.
- Mechanistic modelling of the drying behaviour of single pharmaceutical granules.  
S.T. Mortier, T. De Beer, K.V. Gernaey, **J. Vercruyse**, M. Fonteyne, J.P. Remon, C. Vervaet, I. Nopens.  
European Journal of Pharmaceutics and Biopharmaceutics. 2012, 80 (3), 682-689.
- Innovation in pharmaceutical manufacturing of solid dosage forms by continuous wet granulation  
C. Vervaet, **J. Vercruyse**, J.P. Remon.  
APGI Newsletter, 2011 (26) 13-15.

## INVITED SPEECHES

- Experimental and model-based investigation of twin screw granulation: towards more profound process knowledge.  
2<sup>nd</sup> Continuous oral solid dosage forms production seminar, GEA Pharma Systems, Antwerp, Belgium, June 4<sup>th</sup>-5<sup>th</sup>, 2014.
- Innovation in pharmaceutical manufacturing of solid dosage forms via continuous wet granulation.  
Advanced Pharmaceutical Technology (Master of Science in Drug Development), Ghent University, December 9<sup>th</sup>, 2013.

- Innovation in pharmaceutical manufacturing of solid dosage forms via continuous wet granulation.  
Interphex Japan, Tokyo, Japan, June 27<sup>th</sup>-29<sup>th</sup>, 2012.
- Use of Design of Experiments in R&D.  
AEFI Seminar, Barcelona, Spain, May 16<sup>th</sup>, 2012.
- Twin screw granulation: influence of process variables on granule and tablet quality.  
Pre-conference workshop EuPAT 5, GEA Pharma Systems, Antwerp, Belgium, May 8<sup>th</sup>, 2012.
- Twin screw granulation: a case study.  
1<sup>st</sup> Continuous oral solid dosage forms production seminar, GEA Pharma Systems, Antwerp, Belgium, June 7<sup>th</sup>-8<sup>th</sup>, 2011.
- Use of Design of Experiments in R&D.  
1<sup>st</sup> Continuous oral solid dosage forms production seminar, GEA Pharma Systems, Antwerp, Belgium, June 7<sup>th</sup>-8<sup>th</sup>, 2011.

#### **ORAL PRESENTATIONS AT INTERNATIONAL MEETINGS**

- Impact of screw configuration on the particle size distribution of granules produced by twin screw granulation.  
Kuopio-Ghent summer school in Continuous Manufacturing, Kuopio, Finland, August 20<sup>th</sup>-22<sup>nd</sup>, 2014.
- Experimental study on the particle size distribution of granules produced by twin screw granulation.  
6th International Congress on Pharmaceutical Engineering (ICPE), Graz, Austria, June 16<sup>th</sup>-17<sup>th</sup>, 2014.
- Stability and repeatability of a continuous twin screw granulation and drying system.  
6th International Granulation Workshop, Sheffield, UK, June 26<sup>th</sup>-28<sup>th</sup>, 2013.
- Continuous production and PAT.  
5<sup>th</sup> IDEA meeting, Ghent University and SEPS Pharma, Ghent, Belgium, November 8<sup>th</sup>, 2012.

- Twin screw granulation: influence of formulation and process variables on granule quality.  
4th PSSRC Annual Symposium, Cambridge, UK, September 19<sup>th</sup>-21<sup>st</sup>, 2010.

#### ORAL PRESENTATION AT NATIONAL MEETING

- Twin screw granulation: influence of formulation and process variables on granule quality.  
15<sup>th</sup> Forum of Pharmaceutical Sciences, Spa, Belgium, May 12<sup>th</sup>-13<sup>th</sup>, 2011.

#### POSTER PRESENTATIONS AT INTERNATIONAL MEETINGS

- Evaluation of powder blending performance of a twin screw granulator: an experimental approach.  
9<sup>th</sup> World meeting on Pharmaceutics, Biopharmaceutics and Pharmaceutical Technology, Lisbon, Portugal, March 31<sup>st</sup>– April 3<sup>rd</sup>, 2014.
- Use of a continuous twin screw granulation and drying system during formulation development and process optimization.  
AAPS Annual Meeting and Exhibition, Chicago, USA, October 14<sup>th</sup>-18<sup>th</sup>, 2012.
- Robustness of a continuous twin screw granulation and drying system.  
AAPS Annual Meeting and Exhibition, Chicago, USA, October 14<sup>th</sup>-18<sup>th</sup>, 2012.
- Evaluation of powder blending performance of a twin screw granulator: an experimental approach.  
8<sup>th</sup> World meeting on Pharmaceutics, Biopharmaceutics and Pharmaceutical Technology, Istanbul, Turkey, March 19<sup>th</sup>-22<sup>nd</sup>, 2012.
- Twin screw granulation: influence of formulation and process variables on granule quality.  
AAPS Annual Meeting and Exhibition, Washington, USA, October 23<sup>rd</sup>-27<sup>th</sup>, 2011.
- Continuous twin screw granulation: influence of process parameters on granule and tablet quality.  
5<sup>th</sup> International Granulation Workshop, Lausanne, Switzerland, June 26<sup>th</sup>-28<sup>th</sup>, 2011.

**POSTER PRESENTATION AT INTERNAL MEETING**

- Twin screw granulation: influence of formulation and process variables on granule quality.  
3<sup>rd</sup> Scientific afternoon at FFW, Ghent University, Ghent, Belgium, May 26<sup>th</sup>, 2011.

**ATTENDED COURSES AND WORKSHOPS**

- Communication & Presentation techniques, Ghent University, Ghent, Belgium, April 28<sup>th</sup>, 2014.
- Efficient Product Characterization and Processing of Pharmaceuticals Particulate Solids, Magdeburg, Germany, May 21<sup>st</sup>-31<sup>st</sup>, 2013.
- Course on Design and Implementation of Continuous Pharmaceutical Manufacturing Processes, Zürich, Switzerland, December 12<sup>th</sup>-14<sup>th</sup>, 2012.
- Pre-conference Workshop to EuPAT 5 on Continuous Processing for Tablet Manufacturing, GEA Pharma Systems, Antwerp, Belgium, May 8<sup>th</sup>, 2012.
- Advanced Academic English: Writing Skills, Ghent University, Ghent, Belgium, 2012.
- 2<sup>nd</sup> Symposium on Scale-up of Solid Oral Dosage Forms, Liestal, Switzerland, April 13<sup>th</sup>-14<sup>th</sup>, 2011.
- Granulation & Tableting course, TTC Glatt, Binzen, Germany, October 12<sup>th</sup>-14<sup>th</sup>, 2010.
- Project Management, Ghent University, Ghent, Belgium, December, 2010.
- IWPCPS - 12<sup>th</sup> International Workshop on Physical Characterization of Pharmaceutical Solids, Lille, France, June 21<sup>st</sup>-24<sup>th</sup>, 2010.
- Workshop on Continuous Particle Processing, TTC Glatt, Weimar, June 8<sup>th</sup>-9<sup>th</sup>, 2010.
- Analysis of Variance, Ghent University, Ghent, Belgium, 2010.
- Introductory Statistics, Ghent University, Ghent, Belgium, 2009.
- Multivariate Data Analysis by Umetrics AB (Training in Multivariate Technology), Ghent, Belgium, January 6<sup>th</sup>-7<sup>th</sup>, 2009.
- Design of Experiments "Pharma applications" by Umetrics AB (Training in Multivariate Technology), Ghent, Belgium, December 16<sup>th</sup>-17<sup>th</sup>, 2008.

