



University of Dundee

Mornitoring High Intensity Focused Ultrasound (HIFU) Treatment Using Optical Coherence Tomography

Zhou, Kanheng; Wang, Yan; Wang, Guan; Feng, Kairui; Li, Faqi; Li, Chunhui

Published in:
2018 IEEE International Ultrasonics Symposium, IUS 2018

DOI:
[10.1109/ULTSYM.2018.8580088](https://doi.org/10.1109/ULTSYM.2018.8580088)

Publication date:
2018

Document Version
Peer reviewed version

[Link to publication in Discovery Research Portal](#)

Citation for published version (APA):
Zhou, K., Wang, Y., Wang, G., Feng, K., Li, F., Li, C., & Huang, Z. (2018). Mornitoring High Intensity Focused Ultrasound (HIFU) Treatment Using Optical Coherence Tomography: Feasibility Study. In *2018 IEEE International Ultrasonics Symposium, IUS 2018* (Vol. 2018-October). [8580088] IEEE Computer Society. <https://doi.org/10.1109/ULTSYM.2018.8580088>

General rights

Copyright and moral rights for the publications made accessible in Discovery Research Portal are retained by the authors and/or other copyright owners and it is a condition of accessing publications that users recognise and abide by the legal requirements associated with these rights.

- Users may download and print one copy of any publication from Discovery Research Portal for the purpose of private study or research.
- You may not further distribute the material or use it for any profit-making activity or commercial gain.
- You may freely distribute the URL identifying the publication in the public portal.

Take down policy

If you believe that this document breaches copyright please contact us providing details, and we will remove access to the work immediately and investigate your claim.

Monitoring High Intensity Focused Ultrasound (HIFU) Treatment using Optical Coherence Tomography: Feasibility Study

Kanheng Zhou
School of Science and Engineering
University of Dundee
Dundee, United Kingdom
k.y.zhou@dundee.ac.uk

Kairui Feng
School of Science and Engineering
University of Dundee
Dundee, United Kingdom
k.feng@dundee.ac.uk

Zhihong Huang
School of Science and Engineering
University of Dundee
Dundee, United Kingdom
z.y.huang@dundee.ac.uk

Yan Wang
State Key Laboratory of Ultrasound
Engineering in Medicine, Chongqing
Key laboratory of Biomedical
Engineering, School of Biomedical
Engineering
Chongqing Medical University
Chongqing, P.R. China
y.z.z.q.wang@dundee.ac.uk

Faqi Li
State Key Laboratory of Ultrasound
Engineering in Medicine, Chongqing
Key laboratory of Biomedical
Engineering, School of Biomedical
Engineering
Chongqing Medical University
Chongqing, P.R. China
lifaqi70@163.com

Guan Wang
School of Science and Engineering
University of Dundee
Dundee, United Kingdom
g.w.wang@dundee.ac.uk

Chunhui Li
School of Science and Engineering
University of Dundee
Dundee, United Kingdom

c.li@dundee.ac.uk

Abstract—HIFU is a noninvasive, acoustic therapeutic technique that utilizes high intensity acoustic field in the ultrasound focus to kill the targeted tissue for disease treatment purpose. The feasibility of monitoring and guiding HIFU treatment using the optical property change in the superficial area of biological tissue is explored. Ex-vivo bovine liver tissue was treated using different HIFU doses (same energy level for 0s, 1s, 5s, 9s) in this research. The 3D structure volume and elastogram were acquired in the lesion area after HIFU treatment. The OCT structure images clearly show the boundary of HIFU lesion area and surrounding normal tissue, even for 1s treatment time, which agree well with the elastography results. The average OCT signal intensity and OCT signal attenuation ratio in the lesion area grows as the treatment time increases. Combined with OCT needle probe, the proposed method has a large potential not only to be used for superficial diseases treatment monitoring, but also to be used for high-precision-demanded diseases treatment monitoring, e.g. nervous disease treatment monitoring.

Keywords—high intensity focused ultrasound (HIFU), treatment monitoring, optical property, shear wave elastography, optical coherence tomography, ex-vivo bovine liver

I. INTRODUCTION

HIFU is a non-invasive, acoustic therapeutic technique that utilizes the high intensity acoustic field in the focus to kill the targeted tissue for the purpose of disease treatment. The intensity at HIFU focus typically can reach 1000-10000 W/cm², which is about four to five orders of magnitude higher than the intensity used in the diagnostic ultrasound, e.g. 0.1 W/cm² [1]. The typical shape of HIFU focus is a ‘cigar’ shape, while the size of the focus is determined by the geometry of the transducer [2]. Thermal and mechanical effects of HIFU beam are principally responsible for the therapeutic effects. Thermal effects of HIFU occur when the tissue temperature is over 56 °C for at least 1 s, causing

irreversible tissue death through coagulative necrosis [2]. Mechanical effects of HIFU include radiation pressure, acoustic steaming and cavitation. All of these cause tissue disruptions by high amplitude pressure oscillations, and resulting in tissue death after rupture of cell and nuclear membranes [1]. HIFU has already been used clinically to treat different benign and malignant diseases since 1990s, including prostatic hyperplasia [3], prostate cancer [4], breast fibroadenoma [5], breast cancer [6], uterine fibroids [7], liver cancer [8] and kidney cancer [9].

Due to the therapeutic effects of HIFU, it is important to choose an optimum method for treatment monitoring and guidance. At present, HIFU treatment is either guided by ultrasound or magnetic resonance imaging (MRI). In ultrasound imaging, grey-scale change caused by cavitation is used as an indication of ablation. While in MRI, indirect MRI thermometry is used to indicate the location of HIFU focus [2]. Ultrasound imaging has the advantages of real-time and cost-efficient. However, it also has the problem of low contrast between HIFU lesion and surrounding tissue. MRI imaging has high contrast between HIFU lesion and normal tissue, while the expenses for MRI imaging is high [2]. It also requires MRI compatible HIFU devices. The spatial resolution for both guidance method is up to millimetre, which is not high enough to image and guide HIFU treatment on small area (size at sub-millimetre level) in the early stage of disease development. Thus, a high spatial resolution, high contrast and cost-efficient way is demanded to monitor HIFU treatment real-timely.

Optical coherence tomography (OCT) is a well-established non-contact and non-invasive image modality that utilizes the difference of optical properties (scattering and absorption) inside biological tissue to reveal the anatomical information of the tissue. Compared to ultrasound and MRI imaging, OCT has better spatial resolution up to

micron. The imaging speed of OCT can easily reach video frame rate, and it also has better contrast in B-mode structure image than ultrasound. The penetration depth of this optical image modality is limited to 2 mm in soft tissue, but it is still suitable for monitoring HIFU treatment on the superficial area of the sample.

In this study, the feasibility of monitoring and guiding HIFU treatment using the optical property change in the superficial area of biological tissue is explored. Ex-vivo bovine liver tissue was tested in this study. Different HIFU doses (same energy level for 0s, 1s, 5s, 9s) were applied on the samples. OCT B-mode imaging was used to image the lesion during HIFU treatment in a 2D way (cross-section at HIFU lesion center), and after HIFU treatment in a 3D way. The HIFU lesion area was then evaluated based on OCT signal intensity in the structure image. Functional imaging, e.g. optical coherence elastography, was also employed to evaluate the location of HIFU lesion. The results from OCT B-mode image were then compared with that from functional imaging for cross-validation purpose. The difference of optical property in lesion area and surrounding normal tissue was explored in this study as well.

II. MATERIALS AND METHODS

A. Ex-vivo bovine liver sample

Ex-vivo bovine liver tissue, obtained from a local butcher shop on the same day of sacrifice, was used as samples in this study. The bovine liver tissue was degassed in phosphate-buffered saline (PBS) using a vacuum pump first, and then keep refrigerated for less than 4 hours before doing the experiment. Total 12 ex-vivo bovine liver samples were tested in this study, 3 for each HIFU dose. All the samples were in square shape with each about 20 mm × 20 mm × 4 mm in size.

B. HIFU transducer

The signal-element HIFU transducer employed in this study was designed and manufactured by Chongqing HIFU (China). This HIFU transducer (10.3 MHz working frequency, 8 mm aperture, ~7 mm focal length) was fully characterized before the experiment. 2D normalized pressure field maps and output acoustic power of this transducer were shown in Fig.1(A, B). 2D normalized pressure field map (Fig.1(A)) was measured by a 0.5 mm radius hydrophone. The focal zone was in a ‘cigar’ shape, and the -6dB focus size was measured to be 0.5 mm in diameter (Fig.1(B)). The output acoustic power was calibrated by an acoustic radiation force balance, the relationship between the spatial average temporal average intensity at focus (I_{SATA}) and pre-amplified driving voltage is shown in Fig. 1(C).

C. Optical coherence tomography system

A spectral-domain OCT (SD-OCT) system was employed to monitoring tissue optical property change during HIFU treatment in this paper. The SD-OCT system consists of a broadband laser source (1310 nm central wavelength, ~83 nm bandwidth, 10 mW power), a 90/10 beam splitter, a stationary reference arm, a sample arm with 3D scanning system, and a high-speed spectrometer (line-scan camera, 91.2 kHz sampling frequency, 6.96 μs exposure time, 450 e/count sensitivity). The axial and lateral spatial

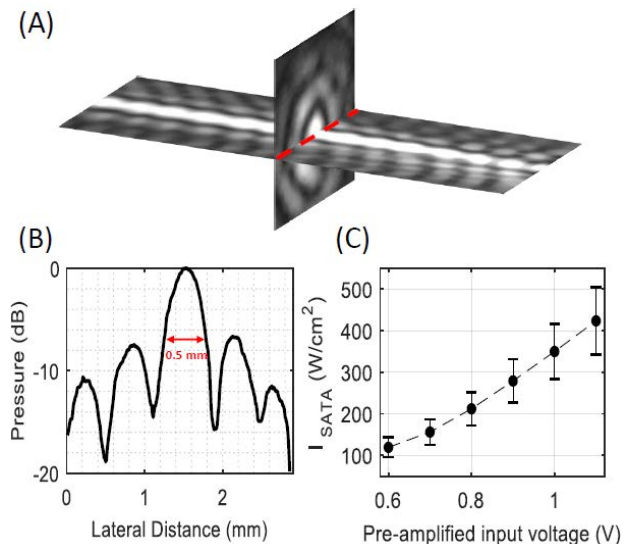

Fig.1 (A) Normalized pressured field of HIFU transducer. (B) Pressure profile (dB) in centre focus with -6 dB width to be 0.5 mm (C) The relationship between the spatial average time average acoustic intensity at focus and pre-amplified driving voltage.

resolution of this system in the sample was ~9.1 μm and ~14.2 μm, respectively. The intensity of backscattered light from different depths of the sample can be evaluated from the spectral interferogram, formed by the light from reference and sample arm, using an inverse Fourier Transform [10]. The motion information (axial displacement) inside sample along optical axis at a given location $uz(x, z, t)$ could be calculated from the phase difference $\Delta\phi(x, z, \Delta t)$ between two consecutive A-line scans at that location using the equation below [10]:

$$uz(x, z, t) = \Delta\phi(x, z, \Delta t) * \lambda / 4\pi n \quad (1)$$

where λ is the central wavelength of the laser source, n is the refractive index of the medium. The phase sensitivity of this system in the sample was ~0.06 rad (5 nm axial displacement).

D. Experimental Setup

The setup for the HIFU treatment monitoring experiment are shown in Fig.2. The HIFU transducer, driven by a function generator and a RF power amplifier, was placed underneath the sample and focused ultrasound beam into the superficial area of the sample, e.g. 50-100 μm below sample surface. The SD-OCT system, working at real-time B-scan mode, was placed above the sample surface to monitoring sample optical property change during HIFU treatment.

The optical coherence elastography experiment (cross-validation purpose) was also performed using the same setup. However, the HIFU transducer was working at low energy level to induce shear wave push only. Degassed water was put surrounded sample to reduce the ultrasound reflection on the sample edge. A thin layer of ultrasound gel was put on the sample surface to suppress surface ripple artifacts in OCT phase image [11]. The SD-OCT system in this experiment was working at M-B scan mode to capture the propagation of induced mechanical wave.

The transducer driving signal was a 700 mVpp continuous sine wave at 10.3 MHz for HIFU treatment monitoring experiment, and a 1000 mVpp burst sine-wave

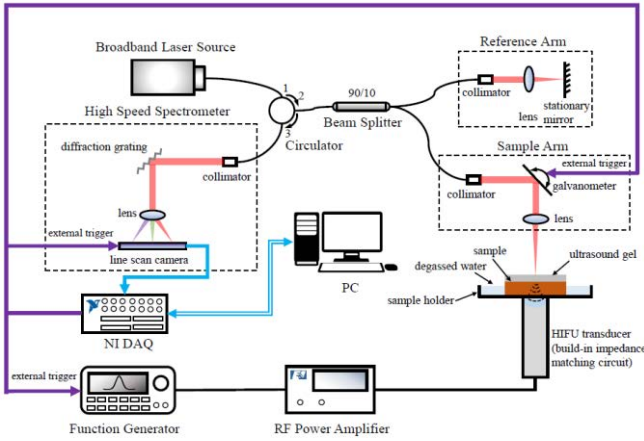

Fig.2 Experimental setup. The HIFU transducer was put underneath the sample to create lesion and generate shear wave in the superficial area of the sample. The SD-OCT system was placed above the sample to monitor HIFU treatment and capture the propagation of induced mechanical wave.

signal with 200 cycles per pulse at 10.3 MHz for optical coherence elastography experiment.

The dataset acquired from OCT system for HIFU treatment monitoring experiment was a 3D structure volume of lesion area. The size of the 3D volume was 1024 pixel-depth (axial) \times 512 B-scans (y axis) \times 512 A-scans (x axis), corresponding to the imaging area of 1.35 mm (depth) \times 2.84 mm (y axis) \times 2.84 mm (x axis). The dataset acquired for optical coherence elastography experiment was the shear wave propagation across the lesion. One complete wave propagation dataset (M-B scan) was 1024 pixel-depth (axial) \times 512 M-scans (lateral) \times 512 A-scans (time frames), corresponding to the 1.35 mm \times 2.84 mm \times 6 ms (depth \times lateral distance \times time). Homebuilt LabVIEW program was used for all data acquisition. Amira and MATLAB were employed for 3D structure data and wave propagation data post-processing, respectively. The elastogram was reconstructed using cross-correlation based time-of-flight method [12-13].

III. RESULTS

The 3D reconstructions of bovine liver tissue with and without HIFU treatment are shown in the left column of Fig.3(A). The size of reconstructed region was 2.84 mm \times 2.84 mm (length \times width). The protruded sample surface was caused by the acoustic radiation force during the HIFU treatment. It is obvious that the HIFU lesion expands with the increase of HIFU treatment time. The size of protruded lesion is directly estimated from the 3D reconstructions to be ~ 0.003 mm³, ~ 0.028 mm³, ~ 0.140 mm³ for 1s, 5s and 9s HIFU treatment, respectively.

The gray-scale OCT B-mode structure images in the middle of normal tissue and at the lesion centre are shown in the middle column of Fig.3(A). The lesion areas are denoted by red circles (dashed) in these figures. The corresponding elastograms are shown in the right column of Fig.3(A) in colour-scale. The structure images clearly shows the boundary of lesion area (bright) and surrounding normal tissue (dark) for different HIFU treatment time. The increasing trend of OCT signal intensity and lesion size with the increase of HIFU treatment time is also shown in these structure images, which agrees well with the corresponding elastograms on the right.

The average OCT signal intensity-depth curve in normal tissue and HIFU lesion, shown in Fig.3 (B) in linear scale and Fig.3(C) in log scale, was obtained by averaging A-lines across normal tissue and lesion area. The OCT signal intensity increases linearly for HIFU treatment time of 0s (normal tissue) to 5s (2923.60 ± 833.55 for 0s to 7181.00 ± 2026.10 for 5s), but only increases slightly after 5s, which means the scattering coefficient of the sample (lesion area) starts to reach its up limit after 5s (Fig.3(D)). After converting OCT signal intensity-depth curve from linear scale to log scale, the OCT signal attenuation ratio could be obtained by fitting the linear part on the curve to a line. The OCT signal attenuation ratio (sample attenuation coefficient) only increases a little from normal tissue to 1s lesion due to small size of the lesion. However, it increases linearly for 1s lesion to 9s lesion from 38.99 dB/mm to 58.45 dB/mm (Fig.3(D)), which also reduce the penetration depth in the sample after HIFU treatment for longer time (Fig.3(C)).

IV. DISCUSSION

In our experimental setup, the driving signal of HIFU transducer for treatment was a 700 mVpp continuous sinewave signal at 10.3 MHz. The corresponding spatial-average time-average acoustic intensity at the focal plane was calculated to be 156 W/cm², which was high enough for therapeutic purpose. However, the driving signal of HIFU transducer for generating shear wave was a 1000 mVpp burst sinewave signal with 200 cycles per pulse at 10.3 MHz. The corresponding spatial-peak temporal average intensity at the focal plane was calculated to be only 6.7 mW/cm², which was much less than the typical diagnostic ultrasound intensity of 720 mW/cm² according to United States Food and Drug Administration (USFDA) regulations [14]. Besides, the maximum HIFU treatment time employed in this experiment was only 9 seconds. This is because the tissue has already been burned through in the center of 9s lesion (Fig.3(A)), which means the sample has already been over-treated.

The maximum penetration depth of SD-OCT is in bovine liver tissue is only ~ 500 μ m (Fig. 3(A)). Hence, the potential applications of this technique are limited to only superficial area of human body. However, OCT needle probe has the flexibility to be inserted into the region of interest for inspection, which could be the potential solution for ‘extending’ the penetration depth of PhS-OCT. Combined with OCT needle probe, the proposed method also has a large potential to be used for high-precision-demanded diseases treatment monitoring inside the body, e.g. nervous disease treatment.

V. CONCLUSION

The feasibility of monitoring HIFU treatment using optical property change of biological soft tissue was explored in this study. The proposed method was demonstrated on ex-vivo bovine liver tissue. The liver tissue was treated at different HIFU dose (same energy level for 0s, 1s, 5s and 9s). The 3D structure volume and elastogram were acquired in the lesion area after HIFU treatment. The OCT structure images clearly show the boundary of HIFU lesion area and surrounding normal tissue, even for 1s treatment time,

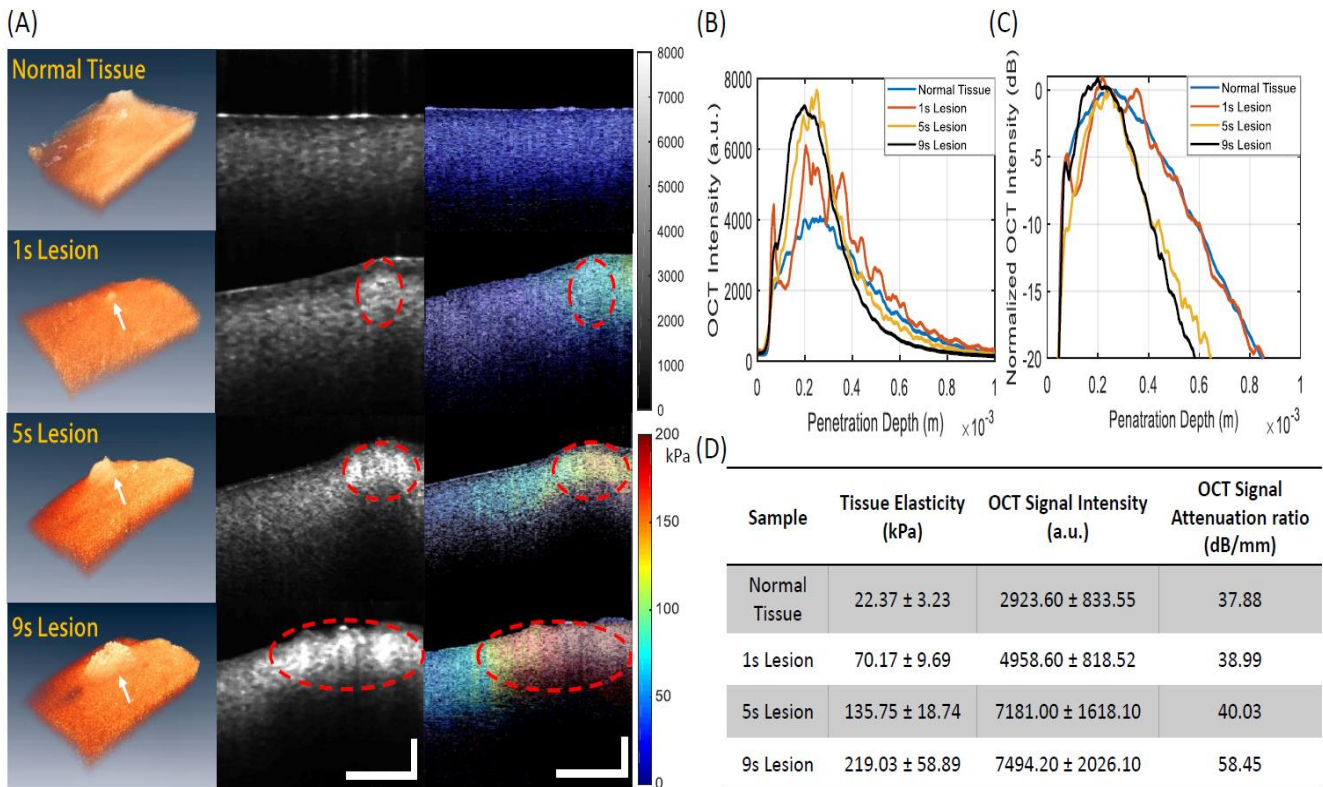

Fig. 3 (A) 3D reconstructions of normal bovine liver tissue and HIFU lesion areas for 1s, 5s and 9s treatment time (left column); OCT B-mode structure images in the middle of normal liver tissue and at centre of HIFU lesion area (middle column); elastograms of normal liver tissue and HIFU lesion areas (right column). HIFU lesions are denoted by red circles in these figures (dashed). Colorbars (white) in both axes represent 200 μm . (B) Average OCT signal intensity-depth curve in normal bovine liver tissue and HIFU lesion area (linear scale). (C) Average OCT signal intensity-depth curve in normal bovine live tissue and HIFU lesion area (log scale). (D) Table summaries lesion elasticity, OCT signal intensity and OCT signal attenuation ratio.

which agree well with the elastography results. The average OCT signal intensity and OCT signal attenuation ratio in the lesion area grows as the treatment time increases. The proposed method has a large potential to be used for real-time HIFU treatment monitoring for diseases in the superficial area of the tissue. Combined with OCT needle probe, it also has a large potential to be used for high-precision-demanded diseases treatment monitoring inside the body, e.g. nervous disease treatment monitoring.

REFERENCES

- [1] Vaezy S, Andrew M, Kaczowski P, Crum L. "Image-guided acoustic therapy," *Annual review of biomedical engineering*, 3(1):375-90 (2001).
- [2] Kennedy JE. "High-intensity focused ultrasound in the treatment of solid tumours," *Nature reviews cancer*, 5(4):321-7 (2005).
- [3] Sanghvi NT, Foster RS, Bihle R, Casey R, Uchida T, et al. "Noninvasive surgery of prostate tissue by high intensity focused ultrasound: an updated report," *Eur. J. Ultrasound*, 9(1):19-29 (1999).
- [4] Gelet A, Chapelon JY, Bouvier R, Rouviere O, Lasne Y, et al. "Transrectal high-intensity focused ultrasound: minimally invasive therapy of localized prostate cancer," *J. Endourol*, 14(6):519-28 (2000).
- [5] Hynynen K, Freund WR, Cline HE, Chung AH, Watkins RD, et al. "A clinical, noninvasive, MR imagingmonitored ultrasound surgery method," *Radiographics*, 16(1):185-95 (1996).
- [6] Med. Data Int. "MRI Guided Ultrasound Used to Treat Patient with Breast Cancer. Medical Industry Today". <http://www.medicaldata.com/> (2000)
- [7] Mencaglia L, Guidetti R, Tonello D, Fanfani A. "Energy focused ultrasound for the clinical treatment of uterine myoma," *Ultrasound Med. Biol.*, 26(2):A207 (2000)
- [8] Kennedy JE, Wu F, Ter Haar GR, Gleeson FV, Phillips RR, Middleton MR, Cranston D. "High-intensity focused ultrasound for the treatment of liver tumours," *Ultrasonics*, 42(1):931-5 (2004)
- [9] Wu F, Wang ZB, Chen WZ, Bai J, Zhu H, Qiao TY. "Preliminary experience using high intensity focused ultrasound for the treatment of patients with advanced stage renal malignancy," *The Journal of urology*, 170(6):2237-40 (2003)
- [10] Wang, R.K.; Kirkpatrick, S.; Hinds, M. "Phase-sensitive optical coherence elastography for mapping tissue microstrains in real time," *Applied Physics Letters*, 90, 164105 (2007)
- [11] Nguyen, T.-M.; Song, S.; Arnal, B.; Huang, Z.; O'Donnell, M.; Wang, R.K. "Visualizing ultrasonically induced shear wave propagation using phase-sensitive optical coherence tomography for dynamic elastography," *Optics letters*, 39, 838-841 (2014)
- [12] Bercoff, J., Chaffai, S., Tanter, M., Sandrin, L., Catheline, S., Fink, M., Gennisson, J.L., and Meunier, M., "In vivo breast tumor detection using transient elastography," *Ultrasound in Medicine & Biology*, 29(10), 1387-1396 (2003)
- [13] McLaughlin, J., and Renzi, D., "Shear wave speed recovery in transient elastography and supersonic imaging using propagating fronts," *Inverse Problems*, 22(2), 681-706 (2006).
- [14] Robert P., Gerald H. "Guidance for Industry and FDA Staff - Information for Manufacturers Seeking Marketing Clearance of Diagnostic Ultrasound Systems and Transducers", 09 September 2008, <https://www.fda.gov/MedicalDevices/ucm070856.htm> (2008).