



**University of Dundee**

**High Intensity Focused Ultrasound (HIFU) Combines Optical Coherence Tomography(OCT) for Biological Tissue Treatment and Evaluation**

Wang, Guan; Wang, Yan; Zhou, Kanheng; Feng, Kairui; Li, Faqi; Li, Chunhui

*Published in:*  
2018 IEEE International Ultrasonics Symposium, IUS 2018

*DOI:*  
[10.1109/ULTSYM.2018.8580216](https://doi.org/10.1109/ULTSYM.2018.8580216)

*Publication date:*  
2018

*Document Version*  
Peer reviewed version

[Link to publication in Discovery Research Portal](#)

*Citation for published version (APA):*  
Wang, G., Wang, Y., Zhou, K., Feng, K., Li, F., Li, C., & Huang, Z. (2018). High Intensity Focused Ultrasound (HIFU) Combines Optical Coherence Tomography(OCT) for Biological Tissue Treatment and Evaluation. In *2018 IEEE International Ultrasonics Symposium, IUS 2018* (Vol. 2018-October). [8580216] IEEE. <https://doi.org/10.1109/ULTSYM.2018.8580216>

**General rights**

Copyright and moral rights for the publications made accessible in Discovery Research Portal are retained by the authors and/or other copyright owners and it is a condition of accessing publications that users recognise and abide by the legal requirements associated with these rights.

- Users may download and print one copy of any publication from Discovery Research Portal for the purpose of private study or research.
- You may not further distribute the material or use it for any profit-making activity or commercial gain.
- You may freely distribute the URL identifying the publication in the public portal.

**Take down policy**

If you believe that this document breaches copyright please contact us providing details, and we will remove access to the work immediately and investigate your claim.

# High Intensity Focused Ultrasound (HIFU) Combines Optical Coherence Tomography(OCT) for biological tissue treatment and evaluation

Guan Wang  
School of Science and Engineering  
University of Dundee  
Dundee, United Kingdom  
[g.w.wang@dundee.ac.uk](mailto:g.w.wang@dundee.ac.uk)

Kairui Feng  
School of Science and Engineering  
University of Dundee  
Dundee, United Kingdom  
[k.feng@dundee.ac.uk](mailto:k.feng@dundee.ac.uk)

Zhihong Huang  
School of Science and Engineering  
University of Dundee  
Dundee, United Kingdom  
[z.y.huang@dundee.ac.uk](mailto:z.y.huang@dundee.ac.uk)

Yan Wang  
State Key Laboratory of Ultrasound  
Engineering in Medicine, Chongqing  
Key laboratory of Biomedical  
Engineering, School of Biomedical  
Engineering  
Chongqing Medical University  
Chongqing, P.R. China  
[y.z.z.q.wang@dundee.ac.uk](mailto:y.z.z.q.wang@dundee.ac.uk)

Faqi Li  
State Key Laboratory of Ultrasound  
Engineering in Medicine, Chongqing  
Key laboratory of Biomedical  
Engineering, School of Biomedical  
Engineering  
Chongqing Medical University  
Chongqing, P.R. China  
[lifaqi70@163.com](mailto:lifaqi70@163.com)

Kanheng Zhou  
School of Science and Engineering  
University of Dundee  
Dundee, United Kingdom  
[k.y.zhou@dundee.ac.uk](mailto:k.y.zhou@dundee.ac.uk)

Chunhui Li  
School of Science and Engineering  
University of Dundee  
Dundee, United Kingdom  
[c.li@dundee.ac.uk](mailto:c.li@dundee.ac.uk)

**Abstract**— High intensity focused ultrasound (HIFU) is an early stage medical technology that is in various stages of development worldwide to treat a range of disorders including skin superficial diseases. Optical coherence tomography (OCT) is a rapid development imaging technique in recent ten years, which is a good way to monitor skin because of the millimeter-level detection depth. In this study, OCT system is used to monitor the skin after HIFU treatment. A new high frequency transducer has been fabricated in this study, focal length of the transducer is super small which is suitable for the superficial diseases.

**Keywords**—High Intensity Focused Ultrasound (HIFU), treatment monitoring, biological optical property, Optical Coherence Tomography (OCT), ex-vivo bovine liver, ex-vivo chicken breast

## I. INTRODUCTION

High intensity focused ultrasound (HIFU) is the only treatment that can be completely non-invasive ablation. In contrast to ionizing radiation, HIFU treatment can be given more than once as there is no upper limit of tissue tolerance to repeated ultrasound exposure. [1] When the ultrasound beam pass through the tissue, it will generate energy, and part of the energy will turn into heat. Under normal circumstances, the heat will be dissipating quickly. But if the heating rate quicker than the cooling rate, local temperature will rise. Thermal toxicity will happen when the temperature up to 56° C. Using HIFU technology, the temperature will rise rapidly at the focal point at around 80° C. [2] Under this situation, even shortest ultrasound exposures can make the cells death effectively. There is an apparently temperature gradient between the focal point and surrounding tissue, which is defined by the boundary between the normal cells and lesion cells in histology. [3]

HIFU treatment is currently used in many different area, especially benign and malignant diseases, also other kinds of treatment, like uterine leiomyoma [4], adenomyosis [5], abdominal liposuction [6], pancreatic cancer [7]. The ability to cause cell death in a volume of tissue distant from the ultrasound source makes HIFU an attractive option for development as a non-invasive surgical tool.

Optical coherence tomography (OCT) is kind of non-invasive image method to provide the structure information inside the biological tissue. [8] Compares to traditional ultrasound monitor method and MRI, OCT got higher resolution, and no requirement of contact [9][10], also no coupling medium required. 3D imaging also can be provided by OCT system.[11]

This research combines two parts: (1) HIFU treatment with the transducer working at high energy level, (2) treatment effect monitored by using OCT system. In this research, ex-vivo bovine liver tissue and ex-vivo chicken breast were treated at the same energy level for different time: 5s, 10s, 15s, 20s, 25s, 30s, respectively. During the treatment, OCT was performed on the lesion area of the sample to monitor the effect of treatment. The lesion area can be evaluated by the OCT results as well as the intensity data based on the structure image.

## II. MATERIAL AND METHODS

### A. HIFU transducer

A customized single element HIFU transducer has been used in this study for the treatment at 10.3MHz which is produced by Chongqing HIFU company in China.



Fig.1 HIFU transducer made by Chongqing HAIFU company.

Acoustic power mapping test and radiation force balance test had been finished before the experiment which are essential factors to characterize the transducer. Diameter of the transducer is 8mm, focal length is around 7mm. The transducer is attached to the coaxial cable, then connected to the BNC connector to the driving signal generator. The customized transducer can be seen in Fig.1 with the outer case.

### B. Optical Coherence Tomography System

In this study, a spectral-domain OCT system was used to monitor the change of different biological tissue optical property during HIFU treatment. The depth of detection is around 3mm which is suitable for detect the optical property change of superficial part.

The SD-OCT system mainly include five parts: broadband laser source, stationary reference arm, flexible sample arm controlled by 3D scanning system, 90/10 beam splitter, high-speed spectrometer camera. Fig.2 shows the SD-OCT system as well as the HIFU transducer. Basically the light beam emitted from the light source and divided into two beams after go through the beam splitter. One of the beams go into the sample arm, and the other go into the reference arm. The sample arm guides the beam onto the sample surface, and the backscattered light from the sample surface interferes with the light reflected from the reference mirror in the circulator. The interference beam is recorded by the line-scan CCD camera. The broadband laser got 1310 nm central wavelength, 83 nm bandwidth and 10 mW power. The high-speed spectrometer is a line-scan CCD camera which has 91.2 kHz sampling frequency and 6.96  $\mu$ s exposure time. The system provides axial and lateral spatial resolution at 9.1  $\mu$ m and 14.2  $\mu$ m, respectively.

### C. Sample Selection

The Ex-vivo bovine liver tissue, ex-vivo chicken breast are purchased from a local farm to make sure them fresh. Both of them need to degassed first by using a vacuum pump before the HIFU treatment in order to decrease the influence of cavitation. After degassed, put all the samples into distilled water to keep it fresh. Under each treatment time, 3 samples has been tested. All the samples has been cutted in to square shape as 15mm\*15mm\*5mm.

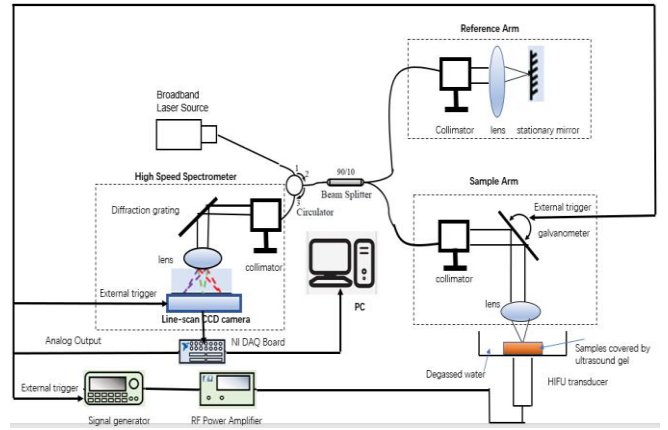

Fig.2 SD-OCT system combine with the HIFU transducer setup

### D. Experimental Setup

HIFU transducer has been put under the samples and the frame created for the transducer can make sure the focal point was showed on the superficial part of the test sample. Put some ultrasound gel on the surface of the sample, to ensure ultrasound propagation. Then connect to signal generator and power amplifier which support such high frequency transducer. Set up for the signal generator was 800mVpp continuous sine wave under 10.3MHz working frequency. The SD-OCT system was working above the sample to monitor the sample optical property change during HIFU treatment.

## III. RESULTS

After HIFU treatment, different size of the lesion area followed by different treatment time can be seen very clearly. As the treatment time increase, the lesion size increase. Also, OCT system shows good results at the same time, structure images of ex-vivo bovine liver tissue shown in Fig.3. The boundary of lesion area and surrounding healthy tissue is easy to tell, which means the HIFU treatment can position the lesion location accurately. Under OCT monitored, the structure image got higher accuracy compares other current monitored method.

Treatment Time(s)	Light Intensity (bovine liver/chicken breast)	
	Mean	STD
5	702.6358/1048.1	56.1126/124.6044
10	710.4934/1324.8	65.4343/302.0443
15	1159.6/1325.6	121.8220/399.9871
20	1565.5/1439.9	228.1320/481.4791
25	2016.7/1469.8	233.9386/151.8502
30	2435.1/1781.1	344.6926/196.1190

Table.1 Light intensity of bovine liver and chicken breast

Structure images of ex-vivo chicken breast tissue shown in Fig.4. Compares to ex-vivo bovine liver, lesion area is not quite clear. Due to the individual different structure of different samples, the size of the lesion is not the same under same energy. The biological structure of bovine liver is quite smooth, but the chicken breast is fibrous, so compares to ex-vivo chicken breast, the shape of the lesion is more regular in the bovine liver.

Also, the lesion size of chicken breast is a little bit smaller than the bovine liver. At the end of the treatment, used thermal sensor to simply measure the temperature of the lesion, bovine liver was higher than chicken breast generally, which should also due to the fibrous structure of the chicken breast. For the light intensity, bovine liver is also higher than the chicken breast.

From Table.1, it clearly shows that the light intensity is increased by the treatment time, which match the structure image and the HIFU dose. The size of lesion area of ex-vivo bovine liver is around  $0.027 \text{ mm}^3$ ,  $\sim 0.108 \text{ mm}^3$ ,  $\sim 0.284 \text{ mm}^3$ ,  $\sim 0.432 \text{ mm}^3$ ,  $\sim 0.504 \text{ mm}^3$ ,  $\sim 1.458 \text{ mm}^3$  for 5s, 10s, 15s, 20s, 25s and 30s HIFU treatment, respectively. The size of lesion area of ex-vivo chicken breast is around  $0.018 \text{ mm}^3$ ,  $\sim 0.027 \text{ mm}^3$ ,  $\sim 0.196 \text{ mm}^3$ ,  $\sim 0.405 \text{ mm}^3$ ,  $\sim 0.605 \text{ mm}^3$ ,  $\sim 1.125 \text{ mm}^3$  for 5s, 10s, 15s, 20s, 25s and 30s HIFU treatment, respectively.

During the HIFU treatment, changes of the structure image was real-time record by the screen recorder. Fig.5 shows the structure changes under 10s treatment at each second. From the figures, it is quite clear to see the difference of the optical property between each second. This proves that OCT is an effective method to monitor the treatment.

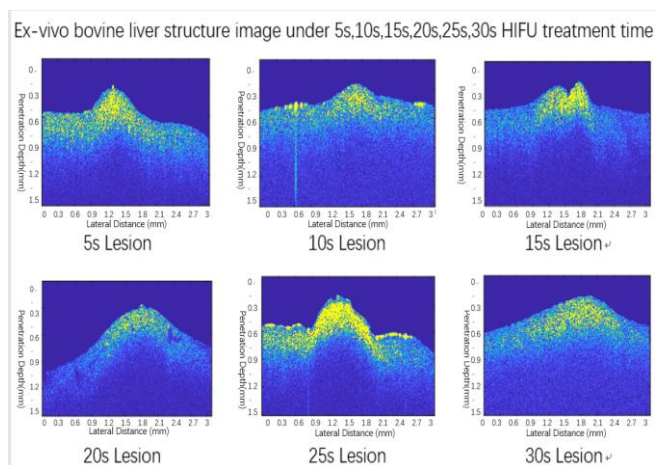

Fig.3 Structure image of ex-vivo bovine liver

Ex-vivo chicken breast structure image under 5s,10s,15s,20s,25s,30s HIFU treatment time

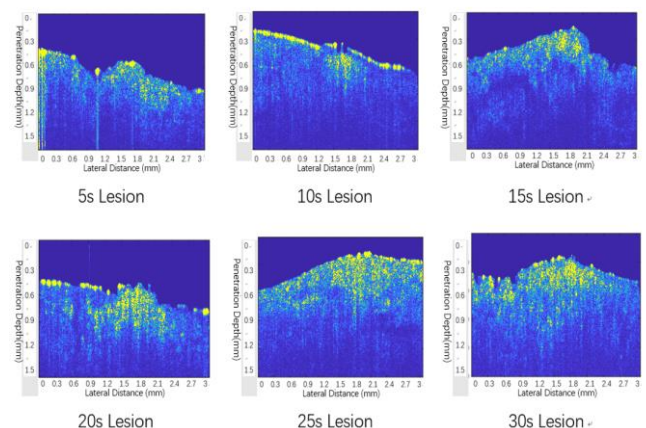

Fig.4 Structure image of ex-vivo chicken breast

#### IV. DISCUSSION AND CONCLUSION

This study explored the feasibility of using OCT to monitor the changes of biological soft tissue optical properties during HIFU treatment. In this experiment, ex-vivo bovine liver tissue and ex-vivo chicken breast tissue were used as samples. The tissue was treated with different treatment time under the same energy. During the HIFU treatment, OCT system was used for monitoring, and OCT results were analyzed after treatment.

The OCT structure images clearly showed the boundary between the HIFU lesion and the surrounding normal tissues. The size of lesion increase followed by the treatment time. The mean OCT signal intensity in the lesion area increase with the increase of treatment time. This method has broad application prospects in the real-time monitoring of HIFU treatment, especially for superficial diseases. Compared with the current ultrasound and MRI monitoring, it has the advantages of high resolution and no contact.

Compared the results of these two kinds of samples--bovine liver and chicken breast, because of the different biological structure, size and shape of lesion, as well as the light intensity are different under same treatment time and energy.

At this stage, the experiment used ex-vivo bovine liver and ex-vivo chicken breast had finished, further experiment will be carried out with various animal skins, like porcine skin. Figure out if there is any difference between different samples. The focal length HIFU transducer used in this study is 3mm which is suitable for treat the superficial disease, as well as the penetration depth of OCT is around 2-3mm. So, system combine OCT monitor and HIFU ablation will be ideal for the treatment of superficial skin disease.

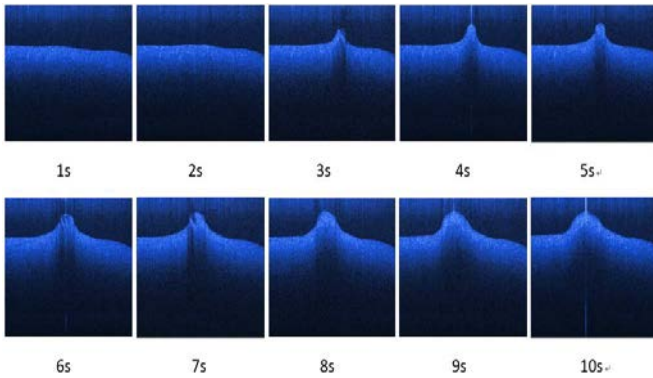

Fig.5 Structure image of ex-vivo bovine liver under 10s HIFU treatment at each second (size of sample area shows in the figure is 3mm\*3mm)

#### ACKNOWLEDGMENT

The high frequency single element transducer used in this study was made by Chongqing HIFU Company. Also grateful thanks to China Scholarship Council for their support.

#### REFERENCES

- [1] F. Orsi, P. Amone, W. Chen, L. Zhang High intensity focused ultrasound ablation: a new therapeutic option for solid tumors J Cancer Res Ther, 6 (2010), pp. 414-420
- [2] L. Crum, et al., "Therapeutic ultrasound: Recent trends and future perspectives," Physics Procedia, vol. 3, pp. 25-34, 2010. J. Clerk Maxwell, A Treatise on Electricity and Magnetism, 3rd ed., vol. 2. Oxford: Clarendon, 1892, pp.68-73.
- [3] Sanghvi NT, Foster RS, Bihrl R, Casey R, Uchida T, et al. "Noninvasive surgery of prostate tissue by high intensity focused ultrasound: an updated report," Eur. J. Ultrasound, 9(1):19-29 (1999).
- [4] TerHaar GR, Rivers JH, CHEN k et al. High intensity focused ultrasound for treatment of rat tumor. Phys Med Biol, 1991, 36 : 1495-1501.
- [5] Pelage JP, Jacob D, Fazel A, et al. Midterm results of uterine artery embolization for symptomatic adenomyosis: initial experience. Radiology 2005; 234:948-953.
- [6] Fruehauf JH, Back W, Eiermann A, et al. High-intensity focused ultrasound for the targeted destruction of uterine tissues: experiences from a pilot study using a mobile HIFU unit. Arch Gynecol Obstet 2008; 227:143-150.
- [7] J.Y. Lee, Choi Byung Ryu Ihn, Ji Kon, et al., Concurrent chemotherapy and pulsed high-intensity focused ultrasound therapy for the treatment of unresectable pancreatic cancer: initial experiences, Korean J. Radiol. 12 (2) (2011) 176-186.
- [8] D. Huang, E. A. Swanson, C. P. Lin, J. S. Schuman, W. G. Stinson, W. Chang, M. R. Hee, T. Flotte, K. Gregory, C. A. Puliafito, J. G. Fujimoto, "Optical coherence tomography", *Science*, vol. 254, pp. 1178-1181, 1991.
- [9] E.M. Frohman, F. Costello, R. Zivadinov, O. Stuve, A. Conger, H. Wi nslow, *et al.* Optical coherence tomography in multiple sclerosis *Lancet Neurol*, 5 (10) (2006), pp. 853-863
- [10] S. Tu, Z. Huang, G. Koning, K. Cui, J.H. Reiber three-dimensional quantitative coronary angiography system: In-vivo comparison with intravascular ultrasound for assessing arterial segment length' *Catheter. Cardiovasc. Interv.*, 76 (2010), pp. 291-298
- [11] Z. Kam D. A. Agard J. W. Sedat "Three-dimensional microscopy in thick biological samples: A fresh approach for adjusting focus and correcting spherical aberration" *Bioimaging* vol. 5 pp. 40-49 1997. P.,