



## Heavy Truck and Bus Traversability at Highway-Rail Grade Crossings

Jennifer Schmidt, Ph.D.  
Research Assistant Professor  
Department of Civil Engineering  
University of Nebraska-Lincoln

Jessica Lingenfelter, B.S.M.E.  
Graduate Research Assistant  
Department of Mechanical and Materials Engineering  
University of Nebraska-Lincoln

A Report on Research Sponsored by

University Transportation Center for Railway Safety (UTCRS)

University of Nebraska-Lincoln

June 2018





*University Transportation Center for Railway Safety  
Fiscal Years 2016-2018*

# **HEAVY TRUCK AND BUS TRAVERSABILITY AT HIGHWAY-RAIL GRADE CROSSINGS**

Submitted by

Jessica L. Lingenfelter, B.S.M.E.  
Graduate Research Assistant

Jennifer D. Schmidt, Ph.D., P.E.  
Research Assistant Professor

Cody S. Stolle, Ph.D., E.I.T.  
Research Assistant Professor

Sagheer A. Ranjha, Ph.D.  
Post-Doctoral Research Associate

Chen Fang, M.E.  
Graduate Research Assistant

Oscar Peña, B.S.C.E  
Graduate Research Assistant

## **MIDWEST ROADSIDE SAFETY FACILITY**

Nebraska Transportation Center  
University of Nebraska-Lincoln

### **Main Office**

Prem S. Paul Research Center at Whittier School  
Room 130, 2200 Vine Street  
Lincoln, Nebraska 68583-0853  
(402) 472-0965

### **Outdoor Test Site**

4630 N.W. 36<sup>th</sup> Street  
Lincoln, Nebraska 68524

Submitted to

## **UNIVERSITY TRANSPORTATION CENTER FOR RAILWAY SAFETY**

The University of Texas Rio Grande Valley  
1201 W University Drive  
Edinburg, Texas 78539

MwRSF Research Report No. TRP-03-392-18

June 29, 2018

## TECHNICAL REPORT DOCUMENTATION PAGE

1. Report No. NTC: 26-1121-0018-011 MwRSF: TRP-03-392-18	2.	3. Recipient's Accession No.	
4. Title and Subtitle Heavy Truck and Bus Traversability at Highway-Rail Grade Crossings		5. Report Date June 29, 2018	
		6.	
7. Author(s) Lingenfelter, J.L., Schmidt, J.D., Stolle, C.S., Ranjha, S.A., Feng, C., and Peña, O.		8. Performing Organization Report No. NTC: 26-1121-0018-011 MwRSF:TRP-03-392-18	
9. Performing Organization Name and Address Midwest Roadside Safety Facility (MwRSF) Nebraska Transportation Center University of Nebraska-Lincoln  Main Office: Prem S. Paul Research Center at Whittier School Room 130, 2200 Vine Street Lincoln, Nebraska 68583-0853		10. Project/Task/Work Unit No.	
		11. Contract (C) or Grant (G) No. DTRT13-G-UTC59	
12. Sponsoring Organization Name and Address University Transportation Center for Railway Safety The University of Texas Rio Grande Valley 1201 W University Drive Edinburg, Texas 78539		13. Type of Report and Period Covered Final Report: 2017-2018	
		14. Sponsoring Agency Code	
15. Supplementary Notes Prepared in cooperation with U.S. Department of Transportation, Federal Highway Administration.			
16. Abstract <p>The objective of this research study was to provide recommendations for traversable highway-rail grade crossings for low, long wheelbase vehicles such as trucks and buses.</p> <p>A literature review was performed to gather information regarding highway-rail grade crossing guidelines, current laws concerning high-profile crossings and signage, crossing maintenance practices, previous work related to highway-rail grade crossing traversability for heavy trucks and buses, and accidents involving low, long wheelbase vehicles becoming high-centered on highway-rail grade crossings. Dimensions for low, long wheelbase trailers, buses, and recreational vehicles were compiled and utilized to determine the most critical vehicles. Drive tests were performed by a tractor-trailer to determine trailer suspension properties, and the information was used to increase the accuracy of vehicle simulation models. Simulations of various highway-rail grade crossings were performed with two vehicle models: a tractor-lowboy and a bus. A range of wheelbases for each vehicle model was tested to determine which vehicles became high-centered on crossings. Based on the results of the TruckSim simulations, a recommended profile for highway-rail grade crossings was recommended.</p> <p>Three highway-rail grade crossings located in Bellevue, Nebraska were 3D scanned to determine the crossing geometries. The three crossings were chosen due to scrape marks on the crossing surfaces seen with Google Maps Street View. The crossings were simulated and it was determined which wheelbases would cause vehicles to become high-centered.</p>			
17. Document Analysis/Descriptors Train Crash, Heavy Truck, Occupant Safety, Crash Safety, Railroad Grade Intersection		18. Availability Statement No restrictions. Document available from: National Technical Information Services, Springfield, Virginia 22161	
19. Security Class (this report) Unclassified	20. Security Class (this page) Unclassified	21. No. of Pages 264	22. Price

## **DISCLAIMER STATEMENT**

This report was completed with funding from the University Transportation Center for Railway Safety (UTCRS). The contents of this report reflect the views and opinions of the authors who are responsible for the facts and the accuracy of the data presented herein. The contents do not necessarily reflect the official views or policies of UTCRS. This report does not constitute a standard, specification, regulation, product endorsement, or an endorsement of manufacturers.



## ACKNOWLEDGEMENTS

The authors wish to acknowledge several sources that made a contribution to this project:

(1) UTCRS for sponsoring the project, (2) MwRSF personnel for constructing the speed table and collecting test data, (3) Crete Carrier for supplying a tractor-trailer for testing, (4) Ed Garrett for performing the speed table tests, (5) Nebraska State Patrol (NSP) Trooper Adam Strode for weighing the tractor-trailer with portable truck scales, and (6) Union Pacific (UP) Railroad Company for allowing 3D scanning of three highway-rail grade crossings.

Acknowledgement is also given to the following individuals who made a contribution to the completion of this research project.

### **Midwest Roadside Safety Facility**

R.K. Faller, Ph.D., P.E., Research Professor & MwRSF Director

J.D. Reid, Ph.D., Professor

J.C. Holloway, M.S.C.E., E.I.T., Assistant Director – Physical Testing Division

K.A. Lechtenberg, M.S.M.E., E.I.T., Research Engineer

R.W. Bielenberg, M.S.M.E., E.I.T., Research Engineer

S.K. Rosenbaugh, M.S.C.E., E.I.T., Research Engineer

M. Asadollahi Pajouh, Ph.D., Post-Doctoral Research Associate

A.T. Russell, B.S.B.A., Testing and Maintenance Technician II

E.W. Krier, Construction and Testing Technician II

S.M. Tighe, Construction and Testing Technician I

D.S. Charroin, Construction and Testing Technician I

M.A. Rasmussen, Construction and Testing Technician I

M.T. Ramel, Construction and Testing Technician I

R.M. Novak, Construction and Testing Technician I

J.E. Kohtz, B.S.M.E., CAD Technician

E.L. Urbank, B.A., Research Communication Specialist

Undergraduate and Graduate Research Assistants

### **University Transportation Center for Railway Safety**

Laurence K. Rilett, Ph.D., P.E., Klassmeyer Chair in Engineering & Technology, Nebraska  
Transportation Center Director

**TABLE OF CONTENTS**

TECHNICAL REPORT DOCUMENTATION PAGE ..... i

DISCLAIMER STATEMENT ..... ii

ACKNOWLEDGEMENTS ..... iii

LIST OF TABLES ..... xiv

1 INTRODUCTION ..... 1

    1.1 Background ..... 1

    1.2 Objective ..... 2

    1.3 Scope ..... 2

2 LITERATURE REVIEW ..... 6

    2.1 Introduction ..... 6

    2.2 Design of Highways and Streets ..... 6

    2.3 Highway-Rail Crossing Signs ..... 6

    2.4 Railroad-Highway Grade Crossing Handbook ..... 8

    2.5 Manual for Railway Engineering ..... 9

        2.5.1 Manual for Railway Engineering (1990) ..... 10

    2.6 Highway-Rail Grade Crossing Guidelines ..... 10

        2.6.1 ICC ..... 11

        2.6.2 SPR ..... 11

    2.7 Design Guidelines for Highway Railroad Grade Crossing Profiles in Florida ..... 12

        2.7.1 Survey Results ..... 12

        2.7.2 Grade Crossing Data Collection ..... 13

        2.7.3 Low Ground Clearance Vehicles in Traffic Streams ..... 13

        2.7.4 State Statute: Moving Heavy Equipment at Railroad Grade Crossings ..... 14

        2.7.5 Recommended Modifications to AREMA and AASHTO Guidelines ..... 15

            2.7.5.1 Vertical Crest Curves ..... 15

            2.7.5.2 Vertical Sag Curves ..... 18

        2.7.6 Calculated Approach Grades ..... 21

        2.7.7 Review of Hump Crossings in Florida ..... 23

        2.7.8 Network Route Based on Crossing Profiles ..... 23

    2.8 Low-Clearance Vehicles at Rail-Highway Grade Crossings ..... 26

        2.8.1 Vehicle Classification ..... 26

        2.8.2 Computer Program: HANGUP ..... 28

    2.9 Identification of Hump Highway-Rail Crossings in Kansas ..... 29

        2.9.1 Surveys ..... 30

            2.9.1.1 Kansas County Surveys ..... 30

            2.9.1.2 State Surveys ..... 31

        2.9.2 Low Ground Clearance and Long Wheelbase Physical Model ..... 32

        2.9.3 HANGUP Program ..... 33

        2.9.4 Kansas Crossing Database ..... 33

    2.10 Highway-Rail Grade Crossing Crashes with High-Centered Vehicles ..... 34

        2.10.1 Crash between Metrolink Train and Tractor-Trailer ..... 34

2.10.2 O&J Trucking Company Crash .....	37
2.10.3 Highway-Rail Grade Crossing Collision Report Summary.....	39
2.10.4 NTSB Investigation Nos. H-84-66 through H-84-68 .....	45
2.10.5 NTSB Railroad Accident Brief.....	46
2.10.6 Bus-Train Crash in Biloxi, Mississippi.....	46
2.10.7 Train-to-Truck Crashes with Limited Data.....	50
2.10.7.1 Lake Worth, Florida, March 16, 1988 .....	50
2.10.7.2 North Miami, Florida, March 22, 2010.....	51
2.10.7.3 Hillsborough, North Carolina, March 23, 2012.....	51
2.10.7.4 Westchester, New York, September 20, 2004 .....	52
2.10.7.5 Springdale Borough, Pennsylvania, October 23, 2013 .....	52
2.10.7.6 Waxahachie, Texas, July 22, 2015.....	52
2.10.7.7 Colorado Springs, Colorado, October 4, 2016.....	53
2.10.7.8 Johnston, South Carolina, May 14, 2015.....	54
2.10.7.9 Rayville, Louisiana, May 5, 2016.....	55
2.10.7.10 Kings Mountain, North Carolina, 2011-2012 .....	55
2.10.7.11 Halifax, North Carolina, March 9, 2015 .....	58
<b>3 SPEED TABLE TESTING.....</b>	<b>59</b>
3.1 Introduction.....	59
3.2 Test Facility .....	59
3.3 Speed Table.....	59
3.4 Test Vehicle .....	60
3.5 Data Acquisition System.....	65
3.5.1 Accelerometer .....	65
3.5.2 Digital Photography .....	67
3.6 Weather Conditions .....	68
3.7 Beginning and End of Test Determination .....	68
3.8 Test Procedure .....	69
3.9 Data Processing.....	73
3.10 Test No. UTCRS-1.....	74
3.11 Test No. UTCRS-2.....	77
3.12 Test No. UTCRS-3.....	80
3.13 Test No. UTCRS-4.....	83
3.14 Results and Discussions .....	86
3.15 Overall Results and Conclusions .....	87
<b>4 FIELD SURVEY OF HIGHWAY-RAIL CROSSINGS IN NEBRASKA .....</b>	<b>88</b>
4.1 Introduction.....	88
4.2 FRA Inventory Forms.....	88
4.3 FRA Accident Reports.....	88
4.4 FRA Safety Map and Google Maps Street View.....	95
4.5 Crossings Selected for 3D Scanning.....	99
4.5.1 Crossing 083312L.....	100
4.5.2 Crossing 073062Y .....	100
4.5.3 Crossing 073158N .....	100
4.5.4 Crossing 817404F .....	101

4.5.5 Crossing 817405M.....	101
4.5.6 Crossing 816134F .....	101
4.5.7 Crossing 083410C.....	102
4.6 Field Survey .....	102
4.6.1 Permission to 3D Scan Crossings .....	102
4.7 Procedure for 3D Scanning Crossings .....	106
4.7.1 Scanning Crossing 817404F .....	108
4.7.2 Scanning Crossing 817405M.....	110
4.7.3 Scanning Crossing 816134F .....	113
4.8 Results of 3D Scanning.....	116
4.8.1 Accuracy of Scans.....	116
4.8.2 Crossing 817404F .....	117
4.8.3 Crossing 817405M.....	119
4.8.4 Crossing 816134F .....	122
4.9 Findings.....	124
4.10 Site Observations and Real-World Problems .....	125
4.11 Additional Discussion Regarding BNSF Crossings .....	125
4.12 Summary.....	125
<b>5 TRACK MAINTENANCE AND REPAIRS.....</b>	<b>127</b>
5.1 Introduction.....	127
5.2 Grade Crossing Jurisdiction.....	127
5.3 Track Maintenance and Repair .....	129
5.3.1 Track Construction.....	130
5.3.2 Track Maintenance.....	130
5.4 Recommendations.....	132
<b>6 MODELING AND SIMULATIONS WITH LS-DYNA .....</b>	<b>134</b>
<b>7 TRUCKSIM PARAMETERS AND METHODS .....</b>	<b>148</b>
7.1 Introduction.....	148
7.2 Static Analysis .....	148
7.3 TruckSim Program.....	149
7.4 Vehicle Models .....	149
7.4.1 Tractor with a Lowboy Trailer.....	149
7.4.2 Bus .....	151
7.5 Vehicle Speed .....	153
7.6 Crossing Configurations .....	153
7.6.1 Railroad Grade Crossing Guidelines .....	153
7.6.2 3D Scanned Crossings .....	157
7.7 Evaluation Criteria.....	159
<b>8 TRUCKSIM RESULTS AND DISCUSSION .....</b>	<b>161</b>
8.1 Baseline Analysis of TruckSim Tractor-Box Trailer Model .....	161
8.1.1 Simulation of Test No. UTCRS-1.....	161
8.1.2 Simulation of Test No. UTCRS-2.....	164
8.1.3 Simulation of Test No. UTCRS-3.....	167
8.1.4 Simulation of Test No. UTCRS-4.....	170

8.1.5 TruckSim Baseline Trailer Model Calibration Using Prior Data .....	173
8.2 AASHTO/AREMA (2015) Guideline Results.....	174
8.2.1 Dynamic Tractor with a Lowboy Trailer in TruckSim.....	174
8.2.2 Dynamic Bus in TruckSim.....	175
8.3 AREMA (1990) Guideline Results.....	176
8.3.1 Static Tractor with a Lowboy Trailer in AutoCAD.....	176
8.3.2 Dynamic Tractor with a Lowboy Trailer in TruckSim.....	177
8.3.3 Dynamic Bus in TruckSim.....	178
8.4 ICC Guideline Results .....	179
8.4.1 Static Tractor with a Lowboy Trailer in AutoCAD.....	179
8.4.2 Dynamic Tractor with a Lowboy Trailer in TruckSim.....	180
8.4.3 Dynamic Bus in TruckSim.....	181
8.5 SPR Guideline Results.....	181
8.5.1 Static Tractor with a Lowboy Trailer in AutoCAD.....	181
8.5.2 Dynamic Tractor with a Lowboy Trailer in TruckSim.....	182
8.5.3 Dynamic Bus in TruckSim.....	183
8.6 Recommendations.....	184
9 SIMULATIONS OF FIELD-SURVEYED GRADE CROSSINGS .....	187
9.1 Crossing 817404F Results .....	187
9.1.1 Dynamic Tractor with a Lowboy Trailer in TruckSim.....	187
9.1.2 Dynamic Bus in TruckSim.....	188
9.2 Crossing 817405M Results .....	189
9.2.1 Dynamic Tractor with a Lowboy Trailer in TruckSim.....	189
9.2.2 Dynamic Bus in TruckSim.....	190
9.3 Crossing 816134F Results .....	191
9.3.1 Dynamic Tractor with a Lowboy Trailer in TruckSim.....	191
9.3.2 Dynamic Bus in TruckSim.....	192
9.4 Discussion and Conclusions .....	193
10 SUMMARY, CONCLUSIONS, AND RECOMMENDATIONS .....	194
10.1 Summary and Conclusions .....	194
10.1.1 Field Testing .....	194
10.1.2 TL-5 LS-DYNA Modeling .....	194
10.1.3 TruckSim Simulations .....	195
10.2 Recommendations.....	195
10.3 Future Research .....	196
11 REFERENCES .....	198
12 APPENDICES .....	203
Appendix A. Inventory Forms .....	204
Appendix B. Accident Reports.....	219
Appendix C. Accelerometer Data Plots, Test Nos. UTCRS-1 through UTCRS-4 .....	227

## LIST OF FIGURES

Figure 1. Train-to-Vehicle Collisions, Injuries, and Fatalities Since 1980 [1].....	4
Figure 2. At Grade Crossing Railway Profile [5] .....	4
Figure 3. Train Crashes with Trucks High-Centered on Train Tracks in (a) Louisiana [6] and (b) North Carolina [7] .....	5
Figure 4. Railroad-Highway Grade Crossing [8].....	6
Figure 5. Example of an Emergency Notification Sign [9] .....	7
Figure 6. Low Ground Clearance Grade Crossing Signs [9] .....	7
Figure 7. ICC Highway-Rail Grade Crossing Guidelines (not to scale).....	11
Figure 8. SPR Highway-Rail Grade Crossing Guidelines (not to scale) .....	12
Figure 9. Low Ground Clearance Vehicle Dimension Diagram [11].....	15
Figure 10. Ramp Breakover Angle Diagram [11] .....	17
Figure 11. Headlight Sight Distance for Determining Vertical Sag Curves [11] .....	19
Figure 12. Critical Approach Grade vs. Wheelbase with 10 ft (3.0 m) Track Width and Various Ground Clearances [11] .....	22
Figure 13. Critical Approach Grade vs. Wheelbase with 15 ft (4.6 m) Track Width with Various Ground Clearances [11] .....	22
Figure 14. Critical Approach Grade vs. Wheelbase with 20 ft (6.1 m) Track Width and Various Ground Clearances [11] .....	23
Figure 15. Railroad Crossing Map with Crossing Identification and Information [11] .....	24
Figure 16. Railroad Crossing Map with Optional Routes and Low Clearance Vehicle Ratings [11].....	25
Figure 17. Railroad Crossing Map with Grade Crossing Photo [11].....	25
Figure 18. HANGUP Manual Mode Output [4] .....	28
Figure 19. HANGUP Automatic Mode Output [4] .....	29
Figure 20. Physical Model Built for Evaluation of Crossings in Kansas Study [18] .....	32
Figure 21. 1997 Peterbilt Tractor and 1992 Aspen Semi-trailer Combination Unit [19].....	34
Figure 22. Grandview Avenue Crossing Diagram [19].....	36
Figure 23. Oil Refinery Condenser Unit and Train [19].....	37
Figure 24. Boogaloo Crossing [5].....	38
Figure 25. Tractor-Trailer Unit Transporting a Turbine in Intercession City, Florida [20] .....	44
Figure 26. Train and Bus in Biloxi, Mississippi Crash After the Train Came to a Stop on March 7, 2017 [40] .....	47
Figure 27. Pepsi Truck after the Train Crash at the Main Street Crossing in Biloxi, Mississippi on January 5, 2017 [41] .....	48
Figure 28. Charter Bus High-Centered at Main Street Crossing in Biloxi, Mississippi on March 12, 2016 [41] .....	49
Figure 29. Main Street Crossing and Low Ground Clearance Sign in Biloxi, Mississippi [37].....	50
Figure 30. Tractor Separated from Auto Transport Trailer [24].....	51
Figure 31. Auto-Transport Trailer High-Centered on Tracks in Waxahachie, Texas [28].....	53
Figure 32. Slow Moving Train Collided with Auto-Transport Trailer [29] .....	54
Figure 33. Sign Posted at Crossing Prohibiting Trucks, Buses, Limousines, and RVs [29] .....	54
Figure 34. Tractor-Lowboy Combination after the Crash [31].....	55
Figure 35. Interstate Semi-trailer after the Crash with the Train [32] .....	56
Figure 36. Low Ground Clearance Warning Sign Posted at Crossing [32].....	56

Figure 37. Second Train Crash at Kings Mountain, North Carolina [35].....57  
Figure 38. Rail Grade Crossing Warning and Scrape Marks at Grade Crossing [35] .....58  
Figure 39. Speed Table for Test Nos. UTCRS-1 through UTCRS-4 .....60  
Figure 40. Speed Table Dimensions ft-in. (mm) .....60  
Figure 41. Crete Carrier Tractor-Trailer .....61  
Figure 42. Vehicle Dimensions, Test Nos. UTCRS-1 through UTCRS-4 .....62  
Figure 43. Portable Heavy Duty Truck Scales Weighing the Crete Carrier Tractor-Trailer .....63  
Figure 44. 3D Scan of the Crete Carrier Tractor-Trailer .....63  
Figure 45. Crete Carrier Tractor-Trailer with Target Stickers.....64  
Figure 46. Air Ride Suspension on the Crete Carrier Tractor .....64  
Figure 47. Leaf Springs on the Right Rear Wheel of the Crete Carrier Trailer.....65  
Figure 48. Leaf Spring Diagram .....65  
Figure 49. VC4000 Accelerometer Mounted on Trailer.....66  
Figure 50. Camera Locations, Types, and Speeds, Test Nos. UTCRS-1 through UTCRS-4.....67  
Figure 51. Beginning of Test for Test Nos. UTCRS-1 through UTCRS-4 .....68  
Figure 52. End of Test for Test Nos. UTCRS-1 through UTCRS-4.....69  
Figure 53. UTCRS Large Truck Drive-Over Test Plan – Page 1 .....70  
Figure 54. UTCRS Large Truck Drive-Over Test Plan – Page 2 .....71  
Figure 55. Target Locations for Test Nos. UTCRS-1 through UTCRS-4.....72  
Figure 56. Target Names for Test Nos. UTCRS-1 through UTCRS-4.....72  
Figure 57. Video Analysis with Target First Position Slightly Elevated.....73  
Figure 58. Sequential Photographs, Test No. UTCRS-1 .....75  
Figure 59. GPS Data Overlaid on Google Earth Image of the Test Site, Test No. UTCRS-1 .....76  
Figure 60. Vertical Displacement, Test No. UTCRS-1 .....76  
Figure 61. Sequential Photographs, Test No. UTCRS-2 .....78  
Figure 62. GPS Data Overlaid on Google Earth Image of the Test Site, Test No. UTCRS-2 .....79  
Figure 63. Vertical Displacement, Test No. UTCRS-2 .....79  
Figure 64. Sequential Photographs, Test No. UTCRS-3 .....81  
Figure 65. GPS Data Overlaid on Google Earth Image of the Test Site, Test No. UTCRS-3 .....82  
Figure 66. Vertical Displacement, Test No. UTCRS-3 .....82  
Figure 67. Sequential Photographs, Test No. UTCRS-4 .....84  
Figure 68. GPS Data Overlaid on Google Earth Image of the Test Site, Test No. UTCRS-4 .....85  
Figure 69. Vertical Displacement, Test No. UTCRS-4 .....85  
Figure 70. FRA Inventory Form – Page 1 [45].....90  
Figure 71. FRA Inventory Form – Page 2 [45].....91  
Figure 72. FRA Accident Report – Page 1 [45].....92  
Figure 73. FRA Accident Report – Page 2 [45].....93  
Figure 74. FRA Accident Query [46] .....94  
Figure 75. FRA Safety Map of the U.S. [47].....95  
Figure 76. FRA Safety Map of Nebraska [47].....96  
Figure 77. FRA Safety Map of Nebraska with Crossing Locations and Map Legend [47] .....96  
Figure 78. FRA Safety Map of Lincoln, Nebraska with Station and Crossing Labels [47] .....97  
Figure 79. FRA Safety Map of Crossing 073158N at Maximum Zoom [47].....98  
Figure 80. Google Street View of Highway-Rail Grade at Crossing 073158N [49].....98  
Figure 81. Google Street View of Highway-Rail Grade at Crossing 073158N [49].....99  
Figure 82. Google Street View of Scrape Marks on Crossing 073158N [49].....99  
Figure 83. UP Nonintrusive Survey Permit – Page 1 .....103

Figure 84. UP Nonintrusive Survey Permit – Page 2 .....104  
Figure 85. UP Nonintrusive Survey Permit – Page 3 .....105  
Figure 86. UP Nonintrusive Survey Permit – Page 4 .....105  
Figure 87. NTC Trailer with Extendable Pole .....107  
Figure 88. NTC Trailer with Faro 3D Scanner Mounted and Extendable Pole Raised.....107  
Figure 89. Locating Spheres, Traffic Cones, and Reflective Scanning Setup .....108  
Figure 90. Crossing 817404F.....109  
Figure 91. West Approach of Crossing 817404F .....109  
Figure 92. East Approach of Crossing 817404F.....110  
Figure 93. Crossing 817405M .....111  
Figure 94. East Approach of Crossing 817405M with Scrape Marks on the Asphalt.....111  
Figure 95. East Approach of Crossing 817405M with Scrape Marks on the Asphalt, Close  
Up.....112  
Figure 96. West Approach of Crossing 817405M with Uneven Crossing Surface .....112  
Figure 97. West Approach of Crossing 817405M with Uneven Crossing Surface, Close Up....113  
Figure 98. Crossing 816134F.....114  
Figure 99. West Approach of Crossing 816134F with Scrape Marks on the Asphalt.....114  
Figure 100. West Approach of Crossing 816134F with Scrape Marks on the Asphalt, Close  
Up.....115  
Figure 101. East Approach of Crossing 816134F with Scrape Marks on the Asphalt .....115  
Figure 102. East Approach of Crossing 816134F with Scrape Marks on the Asphalt, Close  
Up.....116  
Figure 103. Measured Dimensions on W10-1 (left), R1-1 (middle), and R15-1 (right) Signs ...117  
Figure 104. Crossing 817404F FARO Scan Front View .....118  
Figure 105. Crossing 817404F FARO Scan Top View .....118  
Figure 106. Crossing 817404F FARO Scan Angled View .....119  
Figure 107. Crossing 817404F Profile Compared to the AASHTO/AREMA (2015)  
Guidelines .....119  
Figure 108. Crossing 817405M FARO Scan Front View .....120  
Figure 109. Crossing 817405M FARO Scan Top View.....121  
Figure 110. Crossing 817405M FARO Scan Angled View .....121  
Figure 111. Crossing 817405M Profile Compared to the AASHTO/AREMA (2015)  
Guidelines .....122  
Figure 112. Crossing 816134F FARO Scan Front View .....123  
Figure 113. Crossing 816134F FARO Scan Top View .....123  
Figure 114. Crossing 816134F FARO Scan Angled View.....124  
Figure 115. Crossing 816134F Profile Compared to the AASHTO/AREMA (2015)  
Guidelines .....124  
Figure 116. Railroad Line Mileage [10] .....128  
Figure 117. Distribution of Grade Crossings by Location [10] .....128  
Figure 118. Distribution of Grade Crossings by Roadway Classification [10] .....129  
Figure 119. Example of Track Construction [57].....130  
Figure 120. ORNL Test Vehicle Model and ORNL Finite Element Model [63] .....134  
Figure 121. Suspension Components in the Tractor-Trailer Model .....135  
Figure 122. Side Sequential View, (a) Model Developed by Plaxico and Reid and (b)  
Updated Model.....136



Figure 123. Overhead Sequential View, (a) Model Developed by Plaxico and Reid and (b) Updated Model.....137

Figure 124. Speed Table Model, (a) Rigidwall Planar Finite and (b) Brick Solid Element .....138

Figure 125. Side Sequential View, Rigidwall Speed Table Model, Test No. UTCRS-2 .....139

Figure 126. Side Sequential View, Solid Speed Table Model, Test No. UTCRS-2.....140

Figure 127. Overhead Sequential View, Rigidwall and Solid Speed Table Models, Test No. UTCRS-2 .....140

Figure 128. Side Sequential View, Rigidwall Speed Table Model, Test No. UTCRS-3 .....141

Figure 129. Side Sequential View, Solid Speed Table Model, Test No. UTCRS-3.....142

Figure 130. Overhead Sequential View, Rigidwall and Solid Speed Table Models, Test No. UTCRS-3 .....142

Figure 131. Analysis Targets, Test Nos. UTCRS-2 and UTCRS-3 and Model .....144

Figure 132. Change in Y-Displacements, Simulation of Test No. UTCRS-2 .....145

Figure 133. Change in Y-Displacements, Simulation of Test No. UTCRS-3 .....146

Figure 134. Force vs. Displacement Curve for Springs.....147

Figure 135. TruckSim Tractor with a Lowboy Trailer Model.....150

Figure 136. TruckSim Bus Model .....152

Figure 137. Crossing Profile Guideline Comparison.....154

Figure 138. AASHTO/AREMA (2015) Crossing Profiles Simulated with TruckSim.....155

Figure 139. AREMA (1990) Crossing Profiles Simulated with TruckSim.....155

Figure 140. ICC Crossing Profiles Simulated with TruckSim .....156

Figure 141. SPR Crossing Profiles Simulated with TruckSim.....156

Figure 142. Bellevue Crossing Profiles Simulated with TruckSim.....157

Figure 143. Crossing 817404F Profiles Simulated with TruckSim.....158

Figure 144. Crossing 817405M Profiles Simulated with TruckSim .....158

Figure 145. Crossing 816134F Profiles Simulated with TruckSim.....159

Figure 146. Green TruckSim Simulation.....160

Figure 147. Yellow TruckSim Simulation.....160

Figure 148. Red TruckSim Simulation .....160

Figure 149. TruckSim Tractor-Van Trailer Model.....161

Figure 150. Vertical Displacement of Trailer Axles, Simulation of Test No. UTCRS-1.....162

Figure 151. Suspension Compressions of Trailer Axles, Simulation of Test No. UTCRS-1.....163

Figure 152. Vertical Acceleration of Van Trailer from TruckSim and Accelerometer, Test No. UTCRS-1 .....164

Figure 153. Vertical Displacement of Trailer Axles, Simulation of Test No. UTCRS-2.....165

Figure 154. Suspension Compressions of Trailer Axles, Simulation of Test No. UTCRS-2.....166

Figure 155. Vertical Acceleration of Van Trailer from TruckSim and Accelerometer, Test No. UTCRS-2 .....167

Figure 156. Vertical Displacement of Trailer Axles, Simulation of Test No. UTCRS-3.....168

Figure 157. Suspension Compressions of Trailer Axles, Simulation of Test No. UTCRS-3.....169

Figure 158. Vertical Acceleration of Van Trailer from TruckSim and Accelerometer, Test No. UTCRS-3 .....170

Figure 159. Vertical Displacement of Trailer Axles, Simulation of Test No. UTCRS-4.....171

Figure 160. Suspension Compressions of Trailer Axles, Simulation of Test No. UTCRS-4.....172

Figure 161. Vertical Acceleration of Van Trailer from TruckSim and Accelerometer, Test No. UTCRS-4 .....173

Figure 162. Recommended Highway-Rail Grade Crossing Guideline.....185

Figure 163. Recommended Highway-Rail Grade Crossing Guideline with Larger Distance  
Outside of the Rails.....186

Figure 164. Recommended Highway-Rail Grade Crossing Guideline.....196

Figure A-1. Crossing 073062Y Inventory Form – Page 1 [44] .....205

Figure A-2. Crossing 073062Y Inventory Form – Page 2 [44] .....206

Figure A-3. Crossing 073158N Inventory Form – Page 1 [44] .....207

Figure A-4. Crossing 073158N Inventory Form – Page 2 [44] .....208

Figure A-5. Crossing 083312L Inventory Form – Page 1 [44].....209

Figure A-6. Crossing 083312L Inventory Form – Page 2 [44].....210

Figure A-7. Crossing 083410C Inventory Form – Page 1 [44] .....211

Figure A-8. Crossing 083410C Inventory Form – Page 2 [44] .....212

Figure A-9. Crossing 817404F Inventory Form – Page 1 [44].....213

Figure A-10. Crossing 817404F Inventory Form – Page 2 [44].....214

Figure A-11. Crossing 817405M Inventory Form – Page 1 [44] .....215

Figure A-12. Crossing 817405M Inventory Form – Page 2 [44] .....216

Figure A-13. Crossing 816134F Inventory Form – Page 1 [44].....217

Figure A-14. Crossing 816134F Inventory Form – Page 2 [44].....218

Figure B-1. Crossing 073062Y Accident Report – August 4, 2005 [44] .....220

Figure B-2. Crossing 073158N Accident Report – July 10, 1983 [44] .....221

Figure B-3. Crossing 073158N Accident Report – August 2, 1982 [44] .....222

Figure B-4. Crossing 073158N Accident Report – August 23, 1977 [44] .....223

Figure B-5. Crossing 083312L Accident Report – March 4, 2013 [44] .....224

Figure B-6. Crossing 083312L Accident Report – February 5, 1978 [44] .....225

Figure B-7. Crossing 083312L Accident Report – January 14, 1975 [44] .....226

Figure C-1. 10-ms Average Longitudinal Acceleration (SLICE-1), Test No. UTCRS-1 .....228

Figure C-2. Longitudinal Change in Velocity (SLICE-1), Test No. UTCRS-1 .....229

Figure C-3. Longitudinal Change in Displacement (SLICE-1), Test No. UTCRS-1 .....230

Figure C-4. 10-ms Average Lateral Acceleration (SLICE-1), Test No. UTCRS-1.....231

Figure C-5. Lateral Change in Velocity (SLICE-1), Test No. UTCRS-1.....232

Figure C-6. Lateral Change in Displacement (SLICE-1), Test No. UTCRS-1 .....233

Figure C-7. 10-ms Average Vertical Acceleration (SLICE-1), Test No. UTCRS-1 .....234

Figure C-8. Vertical Change in Velocity (SLICE-1), Test No. UTCRS-1 .....235

Figure C-9. Vertical Change in Displacement (SLICE-1), Test No. UTCRS-1 .....236

Figure C-10. 10-ms Average Longitudinal Acceleration (SLICE-1), Test No. UTCRS-2 .....237

Figure C-11. Longitudinal Change in Velocity (SLICE-1), Test No. UTCRS-2 .....238

Figure C-12. Longitudinal Change in Displacement (SLICE-1), Test No. UTCRS-2 .....239

Figure C-13. 10-ms Average Lateral Acceleration (SLICE-1), Test No. UTCRS-2.....240

Figure C-14. Lateral Change in Velocity (SLICE-1), Test No. UTCRS-2.....241

Figure C-15. Lateral Change in Displacement (SLICE-1), Test No. UTCRS-2 .....242

Figure C-16. 10-ms Average Vertical Acceleration (SLICE-1), Test No. UTCRS-2 .....243

Figure C-17. Vertical Change in Velocity (SLICE-1), Test No. UTCRS-2.....244

Figure C-18. Vertical Change in Displacement (SLICE-1), Test No. UTCRS-2.....245

Figure C-19. 10-ms Average Longitudinal Acceleration (SLICE-1), Test No. UTCRS-3 .....246

Figure C-20. Longitudinal Change in Velocity (SLICE-1), Test No. UTCRS-3 .....247

Figure C-21. Longitudinal Change in Displacement (SLICE-1), Test No. UTCRS-3 .....248

Figure C-22. 10-ms Average Lateral Acceleration (SLICE-1), Test No. UTCRS-3.....249

Figure C-23. Lateral Change in Velocity (SLICE-1), Test No. UTCRS-3.....250

Figure C-24. Lateral Change in Displacement (SLICE-1), Test No. UTCRS-3 .....251  
Figure C-25. 10-ms Average Vertical Acceleration (SLICE-1), Test No. UTCRS-3 .....252  
Figure C-26. Vertical Change in Velocity (SLICE-1), Test No. UTCRS-3 .....253  
Figure C-27. Vertical Change in Displacement (SLICE-1), Test No. UTCRS-3.....254  
Figure C-28. 10-ms Average Longitudinal Acceleration (SLICE-1), Test No. UTCRS-4 .....255  
Figure C-29. Longitudinal Change in Velocity (SLICE-1), Test No. UTCRS-4 .....256  
Figure C-30. Longitudinal Change in Displacement (SLICE-1), Test No. UTCRS-4 .....257  
Figure C-31. 10-ms Average Lateral Acceleration (SLICE-1), Test No. UTCRS-4.....258  
Figure C-32. Lateral Change in Velocity (SLICE-1), Test No. UTCRS-4.....259  
Figure C-33. Lateral Change in Displacement (SLICE-1), Test No. UTCRS-4 .....260  
Figure C-34. 10-ms Average Vertical Acceleration (SLICE-1), Test No. UTCRS-4 .....261  
Figure C-35. Vertical Change in Velocity (SLICE-1), Test No. UTCRS-4 .....262  
Figure C-36. Vertical Change in Displacement (SLICE-1), Test No. UTCRS-4.....263

## LIST OF TABLES

Table 1. Critical Approach Grades Based on Wheelbase, Track Width, and Ground Clearance [11].....	21
Table 2. Ground Clearance and Wheelbase Data Collected in West Virginia [4].....	27
Table 3. Critical Vehicle Dimensions for Kansas Study [18].....	33
Table 4. Weather Conditions, Test Nos. UTCRS-1 through UTCRS-4.....	68
Table 5. Sequential Description of Events, Test No. UTCRS-1.....	74
Table 6. Sequential Description of Events, Test No. UTCRS-2.....	77
Table 7. Sequential Description of Events, Test No. UTCRS-3.....	80
Table 8. Sequential Description of Events, Test No. UTCRS-4.....	83
Table 9. Measured Dimensions, Actual Dimensions, and Percent Error for 3D Scans.....	117
Table 10. Tractor-Lowboy Vehicle Models Simulated in TruckSim.....	151
Table 11. Bus Vehicle Models Simulated in TruckSim.....	153
Table 12. Vertical Displacements and Percent Errors for Speed Table Tests and TruckSim Simulations.....	174
Table 13. AASHTO/AREMA (2015) Crossings with Tractor-Lowboy Trailer Vehicle Models.....	175
Table 14. AASHTO/AREMA (2015) Crossings with Bus Vehicle Models.....	176
Table 15. Static Analysis of AREMA (1990) Crossings with Tractor-Lowboy Trailer Vehicle Models.....	176
Table 16. AREMA (1990) Crossings with Tractor-Lowboy Trailer Vehicle Models.....	178
Table 17. AREMA (1990) Crossings with Bus Vehicle Models.....	179
Table 18. Static Analysis of ICC Crossings with Tractor-Lowboy Trailer Vehicle Models.....	179
Table 19. ICC Crossings with Tractor-Lowboy Trailer Vehicle Models.....	180
Table 20. ICC Crossings with Bus Vehicle Models.....	181
Table 21. Static Analysis of SPR Crossings with Tractor-Lowboy Trailer Vehicle Models.....	182
Table 22. SPR Crossings with Tractor-Lowboy Trailer Vehicle Models.....	183
Table 23. SPR Crossings with Bus Vehicle Models.....	184
Table 24. Crossing 817404F with Tractor-Lowboy Trailer Vehicle Models.....	188
Table 25. Crossing 817404F with Bus Vehicle Models.....	189
Table 26. Crossing 817405M with Tractor-Lowboy Trailer Vehicle Models.....	190
Table 27. Crossing 817405M with Bus Vehicle Models.....	191
Table 28. Crossing 816134F with Tractor-Lowboy Trailer Vehicle Models.....	192
Table 29. Crossing 816134F with Bus Vehicle Models.....	193

## 1 INTRODUCTION

### 1.1 Background

Heavy trucks and buses have long wheelbases and low ground clearance which add difficulty when traversing sloped rail grade crossings. Improving the traversability of at-grade rail crossings for large trucks will reduce the time vehicles are on the railway and reduce the potential for trains to collide with heavy trucks.

According to statistics provided by the Federal Railroad Administration (FRA) and Operation Lifesaver, the number of collisions that occur in the United States (U.S.) between vehicles and trains at highway-rail grade crossings has steadily decreased since 1981, as shown in Figure 1 [1]. However, over 2,000 collisions still occurred at highway-rail grade crossings in 2015, resulting in 244 fatalities and 967 injuries. Approximately 500 of those 2,000 annual collisions involve commercial vehicles, including heavy trucks and buses [2].

The American Railway Engineering and Maintenance-of-Way Association (AREMA) published guidelines for the construction of road geometries, including elevations, at rail grade crossings to help vehicles with long wheelbases safely pass over grade crossings [3, 4]. Although the guidelines are intended for tractor trailers, they may not accommodate all extended trailers, including long flatbed trailers. When heavy trucks must make right-angle turns near railroad tracks, the risk of becoming high-centered on the tracks increases. Examples of several accident involving tractor-trailers becoming high centered on the tracks are shown in Figures 2 and 3 [5, 6, 7]. To mitigate accidents that occur between heavy trucks and buses at highway-rail grade crossings, further investigation is needed to determine parameters of traversable slopes and track configurations when considering large vehicle geometries.

A research study was conducted to provide recommendations for traversable railway crossing cross-sections for heavy trucks and buses. Research being proposed in this Phase I study

will support University Transportation Center for Railway Safety (UTCRS) Strategic Research Goal no. 1, “Reducing fatalities and injuries at highway-rail grade crossings (HRGCs),” and supports both UTCRS Research Focus Areas for FY2016, “At-Grade Railway Crossing Safety” and “Railway Operations Safety.” Improving the traversability of heavy trucks over at-grade rail crossings will reduce the time vehicles are on the railway and reduce the potential for trains to collide with heavy trucks.

## **1.2 Objective**

The objective of this research effort was to identify rail grade crossing geometries which may increase susceptibility to vehicles becoming high-centered, and to identify reasons why vehicles continue to become high-centered.

## **1.3 Scope**

The research objectives were accomplished through a series of several tasks. A literature search was conducted to investigate, collect, and identify common at-grade railway cross-sections. Areas that have been problematic for heavy vehicle traversability were identified. Vehicle and trailer dimension data, suspension configurations, and trailer attachments were investigated, and wheelbase and ground clearance were tabulated to determine realistic, but worst-case, crossing conditions. Rail grade crossings within 200 miles (322 km) of the Midwest Roadside Safety Facility (MwRSF) headquarters in Lincoln, Nebraska were investigated using the FRA grade crossing index, and satellite and street-level photography were used to inspect if undercarriage scraping contact marks were visible at or near the crossing, or if the crossing slopes visually appeared to be steep. Those sites were recorded for additional investigation.

Next, the research team collected data on railway crossings, including field measurements of cross-sections at three of the grade crossing sites denoted with scraping marks or steep crossing slopes from the satellite and ground level photography survey. A geometrical, static analysis was

conducted with the vehicle dimensions obtained to determine the limit of railway cross-sections which are traversable with heavy vehicles when neglecting suspension effects.

Next, dynamic analyses were conducted to investigate large truck and trailer movements to identify crossings with likelihood for scraping or potentially gouging into pavement surfaces. Large trucks were modeled traversing highway-rail grade crossings using the multi-body dynamics program TruckSim and finite element analysis (FEA) using LS-DYNA. Suspension data for the proposed vehicle models was collected and a TruckSim vehicle model was developed. The vehicle model was validated utilizing prior test data of a truck traversing a speed table. A simulation matrix was developed and initial truck traversal simulations were conducted. FEA simulations with several railway crossing cross-sections were also performed, and recommendations were provided.

Lastly, a final report was prepared which described the data collected on at-grade railway crossings and vehicle dimensions and properties, static analysis of heavy vehicle traversability, the TruckSim vehicle model, and conclusions and recommendations from the simulation effort.

### Highway-Rail Incidents

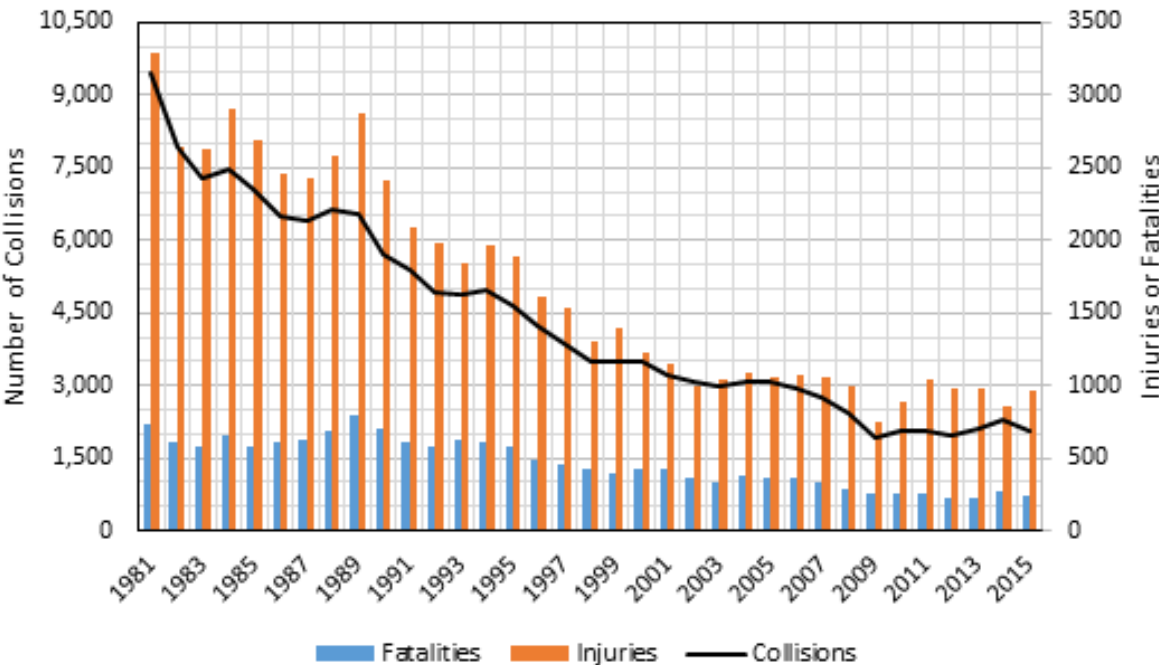

Figure 1. Train-to-Vehicle Collisions, Injuries, and Fatalities Since 1980 [1]

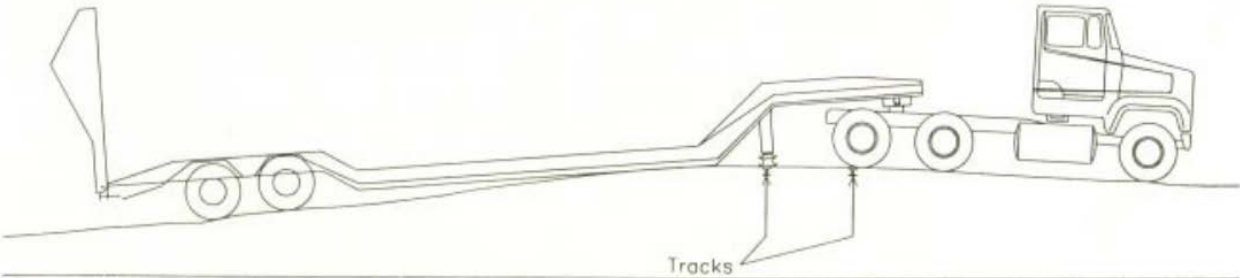

Figure 2. At Grade Crossing Railway Profile [5]





(a)



(b)

Figure 3. Train Crashes with Trucks High-Centered on Train Tracks in (a) Louisiana [6] and (b) North Carolina [7]

## 2 LITERATURE REVIEW

### 2.1 Introduction

In 2015, over 2,000 highway-rail grade crossing crashes occurred in the U.S. [1]. Commercial vehicles, including trucks and buses, were involved in approximately 500 of these crashes [2]. Roadway construction standards, research studies, and thirty crashes regarding low ground clearance vehicles and highway-rail grade crossings are summarized in the following sections.

### 2.2 Design of Highways and Streets

*A Policy on Geometric Design of Highways and Streets* [8], published by the American Association of State Highway and Transportation Officials (AASHTO), contains guidelines for highway and street design. Concerning highway-rail grade crossings, dimensions are specifically recommended for approach grades, which are illustrated in Figure 4. At grade crossings, the crossing surface should be level with the top of the rails extending 2 ft (0.6 m) from the center of each track. The road surface should not be more than 3 in. (76 mm) higher or lower than the top of the rail for 30 ft (9.1 m) adjacent to each rail.

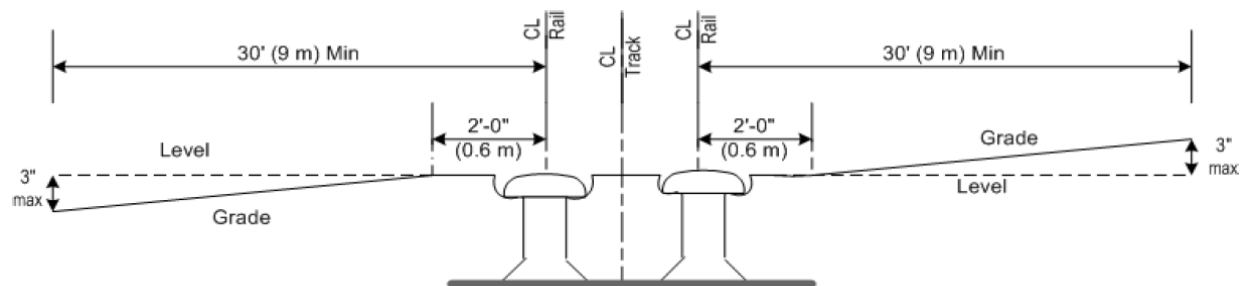

Figure 4. Railroad-Highway Grade Crossing [8]

### 2.3 Highway-Rail Crossing Signs

The *Manual on Uniform Traffic Control Devices (MUTCD) for Streets and Highways*, published by the Federal Highway Administration (FHWA), details regulations for railroad

crossing signs, barricades, and crossing arms [9]. According to Section 8B.18, emergency notification signs (I-13) should be installed at all highway-rail grade crossings. These signs must show an emergency contact telephone number and the United States Department of Transportation (USDOT) crossing inventory number, as shown in Figure 5.



I-13

Figure 5. Example of an Emergency Notification Sign [9]

According to Section 8B.23, low ground clearance grade crossing signs (W10-5 signs) should be installed at grade crossings that could create high-centering situations for long wheelbase vehicles or trailers with low ground clearance, as shown in Figure 6. Furthermore, for the first three years after installing the W10-5 sign, a low ground clearance educational plaque (W10-5P sign) should be installed. The plaque is to notify the public of the W10-5 sign's meaning.

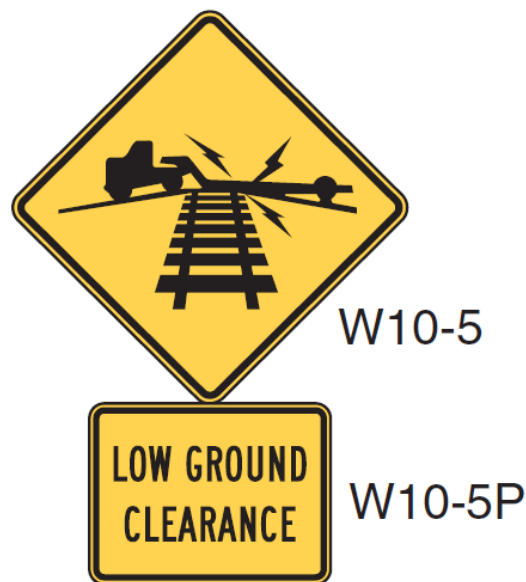

Figure 6. Low Ground Clearance Grade Crossing Signs [9]

## **2.4 Railroad-Highway Grade Crossing Handbook**

The FHWA's *Railroad-Highway Grade Crossing Handbook* [10] is a collection of standards for highway-rail grade crossings. It includes existing laws and regulations, information about active and passive control devices, and summaries of agency responsibilities regarding highway-rail grade crossings.

Highway-rail grade crossing maintenance can be complex because railroad companies maintain jurisdiction over tracks, including at grade crossings, and state and local agencies maintain jurisdiction over the roadways adjacent to grade crossings. Railroad companies are responsible for maintenance of the riding surface at the highway-rail intersection, a responsibility that extends only a few inches outside of the railroad ties. Roadway maintenance by local or state agencies encompasses the roadway approach to the crossing, which may overlap with the railroad's jurisdiction. Depending on the state, jurisdiction could be given to a public service commission or a public administrative agency for the state, county, or city. Consequently, coordination between public government agencies and private railroad agencies is necessary to maintain highway-rail intersections.

The federal government has numerous agencies responsible for highway-rail grade crossing safety, including the Federal Highway Administration (FHWA), the Federal Railroad Administration (FRA), the National Highway Traffic Safety Administration (NHTSA), the Federal Motor Carrier Safety Administration (FMCSA), the Federal Transit Administration (FTA), the National Transportation Safety Board (NTSB), and the Surface Transportation Board (STB). The FRA collaborates with the state and railroad agencies to ensure regulations are met. The American Railway Engineering and Maintenance-of-Way Association (AREMA), though not a government agency, recommends practices pertaining to the design, construction, and maintenance of railway infrastructure.

The *Railroad-Highway Grade Crossing Handbook* [10] also discusses design exceptions for construction of highway-rail crossings. In cases where the standards cannot be met, the reasons and deviations should be documented and saved in a project file by both the highway agency and the railroad company.

## **2.5 Manual for Railway Engineering**

Volume 1, Chapter 5, Section 8.2.1.5 of AREMA's *Manual for Railway Engineering* [3] contains design guidelines for highway-rail grade crossings. Roadway approach grades should follow the following criteria:

“When constructing or reconstructing the roadway approaches to highway/railway grade crossing, the roadway surface should be constructed to be level with said plane through the tops of rails for a distance of at least 24 inches (preferably 60 inches or more) beyond the outer rail of the outermost track in each direction. The top of the rail plane should be connected to the grade line of the roadway in each direction by vertical curves of such length as is consistent with the design criteria normally applied to the functional classification of the roadway under consideration. It is desirable that the surface of the roadway be not more than 3 inches above or 3 inches below the elevation of the top of rail plane, as extended, at a point 30 feet from the outermost rail, measured at right angles thereto. Particular care should be taken to provide a roadway profile that will allow any reasonably anticipated low clearance vehicular traffic to traverse the crossing without hanging up on the crossing or rails. If such a profile is not practicable or feasible, it is recommended the governing roadway authority restrict and sign the crossing and roadway accordingly.”

The manual also states that roadway and railway agencies should collaborate when crossings require maintenance, to agree upon the scope of work, materials to be used, work schedules, and division of costs. Coordination between roadway and railroad agencies is often inconsistent, and rail maintenance may not comply with federal and local guidelines [11].

Volume 3, Chapter 18, Section 2 of the AREMA manual [3] discusses track rehabilitation, which involves restoring tracks to their original condition or upgrading tracks to meet new standards. Section 2.3.4.10 discusses grade crossing rehabilitation and lists other sources of railroad and highway industry standards. These sources include: (1) Chapter 5, Section 8 of the *Manual for Railway Engineering* [3], summarized above; (2) the *Manual on Uniform Traffic Control Devices* [9], previously summarized in Section 2.3; and (3) the *Railroad-Highway Grade Crossing Handbook* [10], previously summarized in Section 2.4.

### **2.5.1 Manual for Railway Engineering (1990)**

AREMA set highway-rail grade crossing guidelines which were adopted into the 1990 edition of *A Policy on Geometric Design of Highways and Streets* [12]. These guidelines state, “Acceptable geometries necessary to prevent drivers of low-clearance vehicles from becoming caught on the tracks would provide the crossing surface at the same plane as the top of the rails for a distance of 2 ft (0.6 m) outside of the rails. The surface of the highway should also not be more than 3 in. (76 mm) higher nor 6 in. (152 mm) lower than the top of the nearest rail at a point 30 ft (9.1 m) outside the outermost rail.”

### **2.6 Highway-Rail Grade Crossing Guidelines**

In addition to the highway-rail grade crossing guidelines published by AASHTO and AREMA, guidelines have been published by the Illinois Commerce Commission (ICC) and the Southern Pacific Railroad (SPR). These guidelines do not state that the crossing grade should be preserved when tracks are raised during maintenance.

### 2.6.1 ICC

The highway-rail grade crossing guidelines from the ICC state, “From the outer rail of the outmost track, the road surface should be level about 24 in. (610 mm). From there to a distance of 25 ft (7.6 m), a maximum grade not to exceed one percent is specified. From that point to the railroad right-of-way line, the maximum grade is five percent” [11]. This crossing profile is shown in Figure 7.

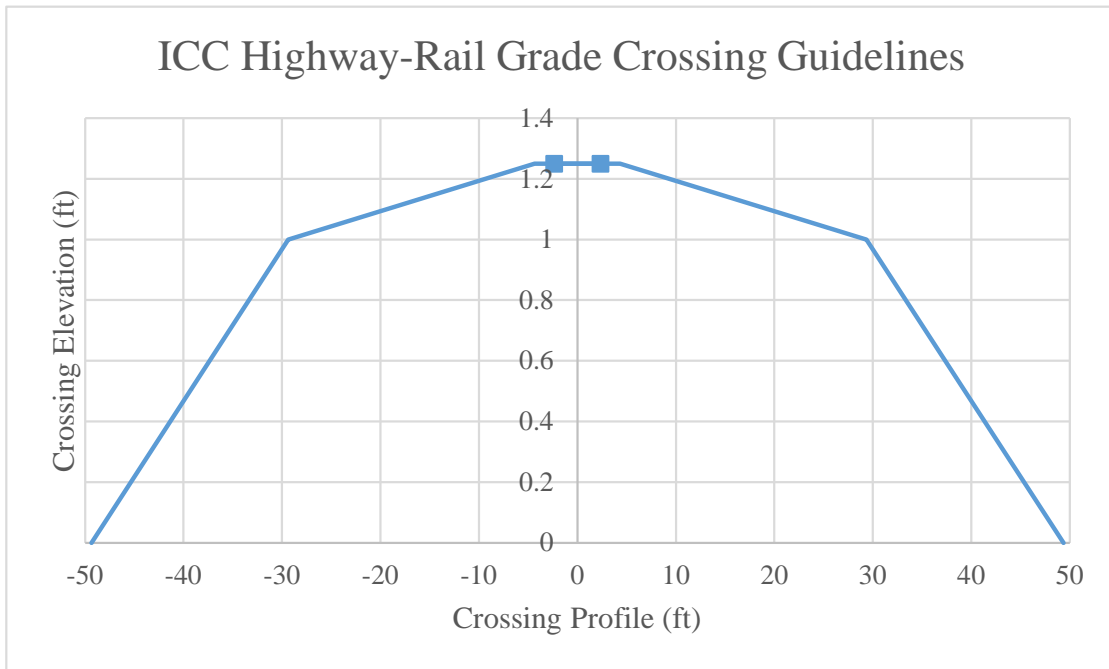

Figure 7. ICC Highway-Rail Grade Crossing Guidelines (not to scale)

### 2.6.2 SPR

SPR’s highway-rail grade crossing guidelines state, “For a distance of 20 ft (6.1 m) from a point 2 ft (0.6 m) from the nearest rail, the maximum descent should be 6 in. (152 mm). From that point for a distance of another 20 ft (6.1 m), the maximum descent should be 2 ft (0.6 m)” [11]. This crossing profile is shown in Figure 8.

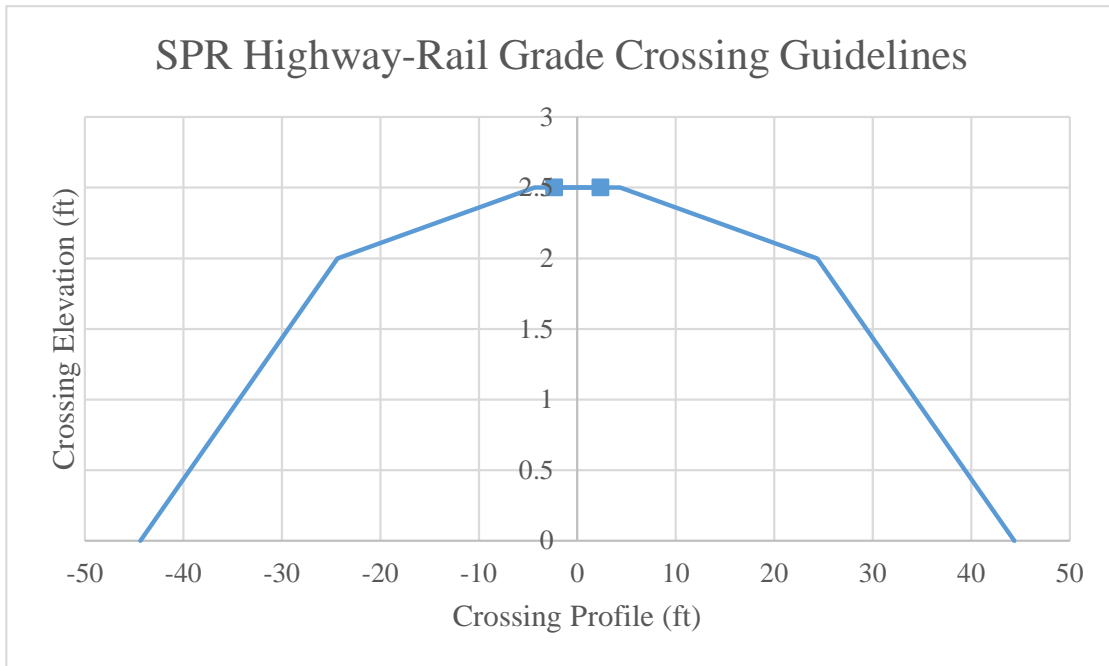

Figure 8. SPR Highway-Rail Grade Crossing Guidelines (not to scale)

## 2.7 Design Guidelines for Highway Railroad Grade Crossing Profiles in Florida

The Florida Department of Transportation (FDOT) sponsored a study to investigate problems at highway-rail grade crossings for low ground clearance vehicles in 2006 [11]. Numerous crashes between trains and vehicles high-centered on railroad crossings in Florida warranted the research study, with the main goal of revising the FDOT manual for grade crossing profile elevation. The research study consisted of a survey sent to state departments of transportation (DOTs) and railroad companies, collection of 3D crossing profile data, calculations for new crossing profile guidelines, and a prototype routing map with high-centering potential indicated at each crossing.

### 2.7.1 Survey Results

Initially, FDOT sent a survey to state DOTs and railroad companies. Thirty-one agencies responded, comprising twenty state transportation departments and eleven railroad companies. From the survey, it was determined that four agencies have formal guidelines for design, construction, and maintenance of grade crossings beyond the AASHTO policies concerning low



ground clearance vehicles. Six agencies have programs in place for maintenance of grade crossings that result in compliant roadway profiles.

The survey also inquired as to the cause of low ground clearance vehicles becoming high-centered at grade crossings. Both state DOTs and railroad companies cited roadway design, construction, and crossing maintenance as causes for vehicles becoming high-centered on highway-rail grade crossings due to the creation of sufficiently steep approach slopes. Highway-rail grade crossing geometry may cause vehicles to become high-centered due to design, construction, or maintenance. Furthermore, seventeen responding agencies, or 55 percent, considered vehicles becoming high-centered at grade crossings to be a major safety issue and nine responding agencies have conducted or plan to conduct research concerning the issue.

### **2.7.2 Grade Crossing Data Collection**

To collect local crossing data, twenty-eight grade crossings located in or near Tallahassee, Florida were documented using a laser profilometer. It was found that the profilometer would not yield accurate data without proper calibration and further advances in the technology. Other options for collecting crossing data include a rotary laser level, a laser rangefinder, a 3D laser scanner, a global positioning system (GPS), as-built construction drawings, an aerial survey, geographical information systems (GIS) data, a contour map, or 3D digital photography. These methods are more expensive than the profilometer, but yield more accurate results.

### **2.7.3 Low Ground Clearance Vehicles in Traffic Streams**

To determine the percentage of low ground clearance vehicles in rural and urban traffic streams, FDOT conducted vehicle counts at three weigh stations in Florida. Annual average daily traffic (AADT) and truck traffic were counted at each location. Then, a truck factor, or percentage of trucks in the AADT, was calculated. Finally, a percentage of low clearance vehicles at each location was estimated. No conclusive definition of “low ground clearance vehicle” was

established in the Florida report [11]. It was found that rural traffic streams contained between five and six percent of low ground clearance vehicles, and urban traffic streams contained around ten percent.

#### **2.7.4 State Statute: Moving Heavy Equipment at Railroad Grade Crossings**

Prior to the publication of *Design Guidelines for Highway Railroad Grade Crossing Profiles in Florida* [11], Florida established statute 316.170 for moving heavy equipment at highway-rail grade crossings:

1. No person shall operate or move any crawler-type tractor, steam shovel, derrick, or roller or any equipment or structure having a normal operating speed of 10 or less MPH or a vertical body or load clearance of less than ½ inch per foot of the distance between any two adjacent axles or in any event of less than 9 inches, measured above the level of surface of a roadway, upon or across any tracks at a railroad grade crossing without first complying with this section.
2. Notice of such intended crossing shall be given to a station agent or other proper authority of the railroad, and a reasonable time shall be given to the railroad to provide protection at the crossing.
3. The person operating or moving any such vehicle or equipment shall first stop the same not less than 15 feet nor more than 50 feet from the nearest rail of the railroad and while so stopped shall listen and look in both directions along the track for any approaching train, and shall not proceed until the crossing can be made safely.
4. No such crossing shall be made when warning is being given by automatic signal or crossing gates or a flagger or otherwise of the immediate approach of a railroad train or car. If a flagger is provided by the railroad, movement over the crossing shall be under his or her direction.

Thirty-two states and the District of Columbia currently have the same statute in place [13]. The remaining eighteen states do not require low ground clearance vehicle operators to notify the railroad company before attempting to traverse the crossing. Of these eighteen states, ten states do not have any statutes regarding low ground clearance vehicles. However, laws are not always followed, as illustrated in the Intercession City crash, summarized in Section 2.10.3.

### 2.7.5 Recommended Modifications to AREMA and AASHTO Guidelines

The FDOT study utilized research performed by McConnell and Bauer in 1958 regarding vehicle overhang and ground clearance causing vehicles to become stuck on driveways [14, 15]. Information in *A Policy on Geometric Design of Highways and Streets* [8] Section 3.4.6 for vertical curves was also utilized. Further analysis of these concepts resulted in proposed recommendations to the following guidelines: AASHTO railroad-highway grade crossing guidelines found in *A Policy on Geometric Design of Highways and Streets* [8] Section 9.12.2 and AREMA roadway approach grade guidelines found in the *Manual for Railway Engineering* [3] Chapter 5, Section 8.2.1.5.

#### 2.7.5.1 Vertical Crest Curves

Ramp breakover angle has been used to evaluate the possibility of passenger vehicles becoming high-centered on driveways [14, 15]. Sobanjo utilized the concept to evaluate the possibility of low ground clearance vehicles becoming high-centered on highway-rail grade crossings [11]. Figure 9 illustrates dimensions of a low ground clearance vehicle on a vertical crest curve, where  $l_w$  is wheelbase,  $c$  is ground clearance, and  $\alpha_1$  and  $\alpha_2$  are the formed angles shown.

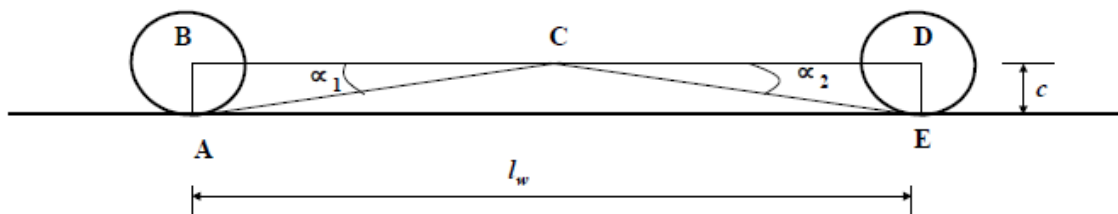

Figure 9. Low Ground Clearance Vehicle Dimension Diagram [11]

The values of  $\alpha_1$  and  $\alpha_2$  can be calculated with the following equation:

$$\tan \alpha = \frac{c}{0.5l_w}$$

where  $\alpha$  = angle in degrees enclosed by a plane joining the nearest wheel low point to the lowest point under the vehicle and the flat ground surface

$c$  = vehicle ground clearance in in.

$l_w$  = vehicle wheelbase in ft

The ramp breakover angle, or the critical slope for an approach grade,  $\beta$ , can be calculated with the following equation:

$$\beta = \alpha_1 + \alpha_2$$

where  $\beta$  = ramp breakover angle in degrees

$\alpha_1$  = angle in degrees enclosed by a plane joining the nearest rear wheel low point to the lowest point under the vehicle and the flat ground

$\alpha_2$  = angle in degrees enclosed by a plane joining the nearest front wheel low point to the lowest point under the vehicle and the flat ground

The critical high-center situation will occur when the midpoint of the wheelbase contacts the ground, as shown in Figure 10. In this case,  $\alpha_1$  and  $\alpha_2$  will be equal and the above equation simplifies to the following:

$$\beta = 2\alpha$$

where  $\beta$  = ramp breakover angle in degrees

$\alpha$  = angle in degrees enclosed by a plane joining the nearest wheel low point to the lowest point under the vehicle and the flat ground surface

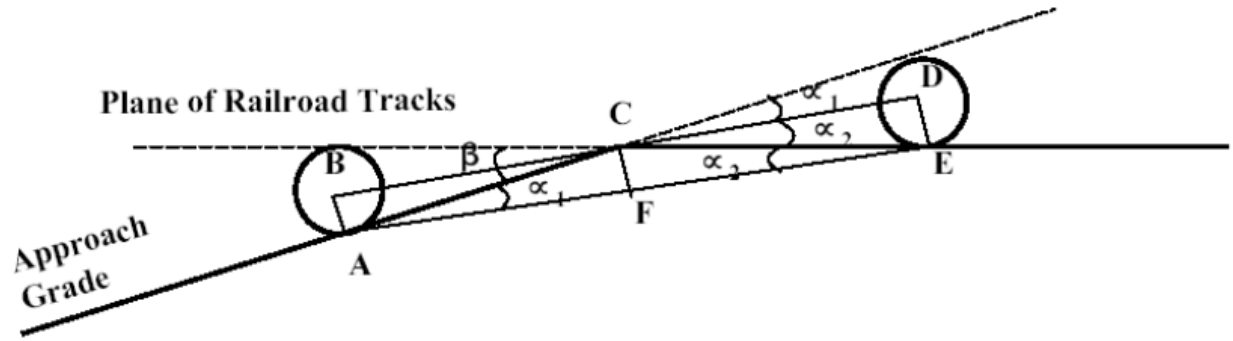

Figure 10. Ramp Breakover Angle Diagram [11]

Furthermore, the critical grade for the crossing,  $G_c$ , can be determined relative to the flat plane of the railroad tracks by the following equation:

$$G_c = \tan \beta$$

where  $G_c$  = critical grade

$\beta$  = ramp breakover angle in degrees

Based on research performed by the West Virginia University Department of Civil and Environmental Engineering, the critical vehicle for wheelbase relative to ground clearance is an auto-transport trailer [16]. The wheelbase and ground clearance for this type of vehicle are 40 ft (12.2 m) and 4 in. (102 mm), respectively. From these values, a critical grade of 3.33% was calculated. It was also determined that, based on Figure 10, the critical high-center will occur at the midpoint of the wheelbase length. Therefore, the flat plane of the railroad tracks should span half of the wheelbase length, or 20 ft (6.1 m) based on the critical vehicle wheelbase length.

These calculated values formed the basis for recommended modifications to the AREMA roadway approach grade and the AASHTO railroad-highway grade crossing guidelines for design of vertical crest curves. The suggested changes to the original guidelines are bolded.

“To prevent low-clearance vehicles from becoming caught on the tracks, **located on crest vertical curve**, the crossing surface should be of the same plane as the top of the rails for

a distance of **7.5** feet outside the rails. The surface of the highway should also not be more than **9** inches lower than the top of the nearest rail at a point 30 feet from the rail, **measured at right angle thereto**, unless track superelevation makes a different level appropriate. Vertical curves **of 20 ft lengths** should be used to traverse from the highway grade to a level plane at the elevation of the rails, **ensuring that the change in tangent grades does not exceed 3.33%**. Rails that are superelevated, or a roadway approach that is not level, will necessitate a site specific analysis for rail clearances, **but in most cases, two tangents can be used to fit 20 ft vertical curve, ensuring that the change in tangent grades does not exceed a value equal to 3.33% plus the rails superelevation rate in percent.**”

Despite utilizing the critical vehicle characteristics to formulate guideline recommendations, the methodology shown in Figure 10 and subsequent equations was not complete. Suspension properties, load distribution, and specifically crossing backslope were not taken into consideration, all of which would affect a vehicle’s ability to traverse a crossing.

#### **2.7.5.2 Vertical Sag Curves**

The AASHTO vertical curve guidelines found in *A Policy on Geometric Design of Highways and Streets* 3<sup>rd</sup> Edition [17] Section 3.4.6 for determining vertical sag curves is based on headlight sight distance. Sight distance is illustrated in Figure 11 and given by the following equation:

$$L = 2S - \frac{200(H + S \tan \delta)}{A}$$

where  $L$  = parabolic curve length in ft

$S$  = sight distance in ft

$H$  = headlight beam height in ft

$\delta$  = headlight beam inclination angle to the horizontal

$A$  = algebraic difference between the approach grades in percent

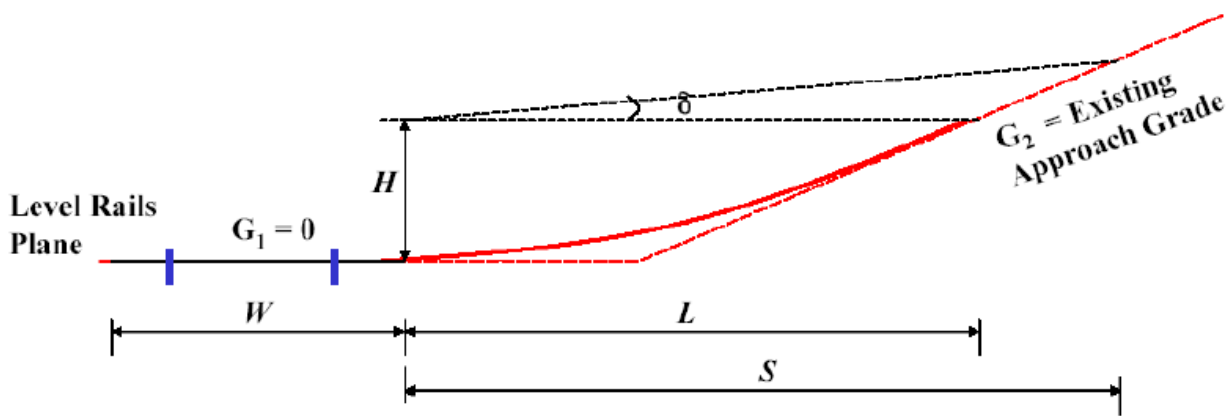

Figure 11. Headlight Sight Distance for Determining Vertical Sag Curves [11]

For low ground clearance vehicle high-centering, this equation can be used by setting  $\delta$  equal to zero and setting  $L$  equal to  $S$  [11]. Furthermore,  $H$  is equal to  $c$ , the ground clearance of the vehicle. The equation simplifies to the following:

$$L = \frac{200c}{A}$$

where  $L$  = vehicle overhang length in ft

$c$  = vehicle ground clearance in ft

$A$  = algebraic difference between the approach grades in percent

In this equation,  $L$  is the length of vehicle overhang and  $c$  is the ground clearance in feet. The value  $A$  is the difference between the approach grades  $G_1$  and  $G_2$  in percent, shown in Figure

11. The equation can be further simplified by setting  $G_1$  equal to zero, due to the flat railroad tracks, as shown in the following equation:

$$L = \frac{200c}{G_2}$$

where  $L$  = critical curve length in ft

$c$  = vehicle ground clearance in ft

$G_2$  = nonzero approach grade in percent

The critical vehicle for vertical sag curves was determined to be a single unit transit bus with an overhang length of 18 ft (5.5 m) and a ground clearance of 6 in. (152 mm) [16]. A critical approach angle of 5.55% was calculated. By using the same ground clearance, but with a length of 20 ft (6.1 m) for the critical wheelbase length, a critical approach angle of 5.00% was calculated.

These calculated values formed the basis for recommended modifications to the AREMA roadway approach grade and the AASHTO railroad-highway grade crossing guidelines for design of vertical sag curves. The suggested changes to the original guidelines are bolded.

“To prevent low-clearance vehicles from becoming caught on the tracks, **located on sag vertical curve**, the crossing surface should be of the same plane as the top of the rails for a distance of **10** feet outside the rails. The surface of the highway should also not be more than **6** inches higher than the top of the nearest rail at a point **20** feet from the rail, **measured at right angle thereto**, unless track superelevation makes a different level appropriate. Vertical curves **of 20 ft lengths** should be used to traverse from the highway grade to a level plane at the elevation of the rails, **ensuring that the change in tangent grades does not exceed 5%**. Rails that are superelevated, or a roadway approach that is not level, will necessitate a site specific analysis for rail clearances, **but in most cases, two tangents can**



**be used to fit 20 ft vertical curve, ensuring that the change in tangent grades does not exceed a value equal to 5% plus the rails superelevation rate in percent.”**

### 2.7.6 Calculated Approach Grades

Using the equations listed in Section 2.7.5.1, values for the maximum approach grade were calculated based on various wheelbase, track width, and ground clearance values, as shown in Table 1. The calculated approach angles were graphed, as shown in Figures 12, 13, and 14.

Table 1. Critical Approach Grades Based on Wheelbase, Track Width, and Ground Clearance [11]

Wheelbase (ft.)	Maximum Approach Grade, $G_{critical}$ (Tracks Width $W = 10$ ft.)			Maximum Approach Grade, $G_{critical}$ (Tracks Width $W = 15$ ft.)			Maximum Approach Grade, $G_{critical}$ (Tracks Width $W = 20$ ft.)		
	Ground Clearance, $c = 4$ in.	Ground Clearance, $c = 6$ in.	Ground Clearance, $c = 8$ in.	Ground Clearance, $c = 4$ in.	Ground Clearance, $c = 6$ in.	Ground Clearance, $c = 8$ in.	Ground Clearance, $c = 4$ in.	Ground Clearance, $c = 6$ in.	Ground Clearance, $c = 8$ in.
20	6.60%	10.00%	13.40%	13.20%	20.00%	26.80%			
22	5.50%	8.33%	11.17%	9.43%	14.29%	19.14%	33.00%	50.00%	67.00%
24	4.71%	7.14%	9.57%	7.33%	11.11%	14.89%	16.50%	25.00%	33.50%
26	4.13%	6.25%	8.38%	6.00%	9.09%	12.18%	11.00%	16.67%	22.33%
28	3.67%	5.56%	7.44%	5.08%	7.69%	10.31%	8.25%	12.50%	16.75%
30	3.30%	5.00%	6.70%	4.40%	6.67%	8.93%	6.60%	10.00%	13.40%
32	3.00%	4.55%	6.09%	3.88%	5.88%	7.88%	5.50%	8.33%	11.17%
34	2.75%	4.17%	5.58%	3.47%	5.26%	7.05%	4.71%	7.14%	9.57%
36	2.54%	3.85%	5.15%	3.14%	4.76%	6.38%	4.13%	6.25%	8.38%
38	2.36%	3.57%	4.79%	2.87%	4.35%	5.83%	3.67%	5.56%	7.44%
40	2.20%	3.33%	4.47%	2.64%	4.00%	5.36%	3.30%	5.00%	6.70%
42	2.06%	3.13%	4.19%	2.44%	3.70%	4.96%	3.00%	4.55%	6.09%
44	1.94%	2.94%	3.94%	2.28%	3.45%	4.62%	2.75%	4.17%	5.58%
46	1.83%	2.78%	3.72%	2.13%	3.23%	4.32%	2.54%	3.85%	5.15%
48	1.74%	2.63%	3.53%	2.00%	3.03%	4.06%	2.36%	3.57%	4.79%
50	1.65%	2.50%	3.35%	1.89%	2.86%	3.83%	2.20%	3.33%	4.47%
52	1.57%	2.38%	3.19%	1.78%	2.70%	3.62%	2.06%	3.13%	4.19%
54	1.50%	2.27%	3.05%	1.69%	2.56%	3.44%	1.94%	2.94%	3.94%
56	1.43%	2.17%	2.91%	1.61%	2.44%	3.27%	1.83%	2.78%	3.72%
58	1.38%	2.08%	2.79%	1.53%	2.33%	3.12%	1.74%	2.63%	3.53%
60	1.32%	2.00%	2.68%	1.47%	2.22%	2.98%	1.65%	2.50%	3.35%
62	1.27%	1.92%	2.58%	1.40%	2.13%	2.85%	1.57%	2.38%	3.19%
64	1.22%	1.85%	2.48%	1.35%	2.04%	2.73%	1.50%	2.27%	3.05%
66	1.18%	1.79%	2.39%	1.29%	1.96%	2.63%	1.43%	2.17%	2.91%
68	1.14%	1.72%	2.31%	1.25%	1.89%	2.53%	1.38%	2.08%	2.79%
70	1.10%	1.67%	2.23%	1.20%	1.82%	2.44%	1.32%	2.00%	2.68%
72	1.06%	1.61%	2.16%	1.16%	1.75%	2.35%	1.27%	1.92%	2.58%
74	1.03%	1.56%	2.09%	1.12%	1.69%	2.27%	1.22%	1.85%	2.48%
76	1.00%	1.52%	2.03%	1.08%	1.64%	2.20%	1.18%	1.79%	2.39%
78	0.97%	1.47%	1.97%	1.05%	1.59%	2.13%	1.14%	1.72%	2.31%
80	0.94%	1.43%	1.91%	1.02%	1.54%	2.06%	1.10%	1.67%	2.23%

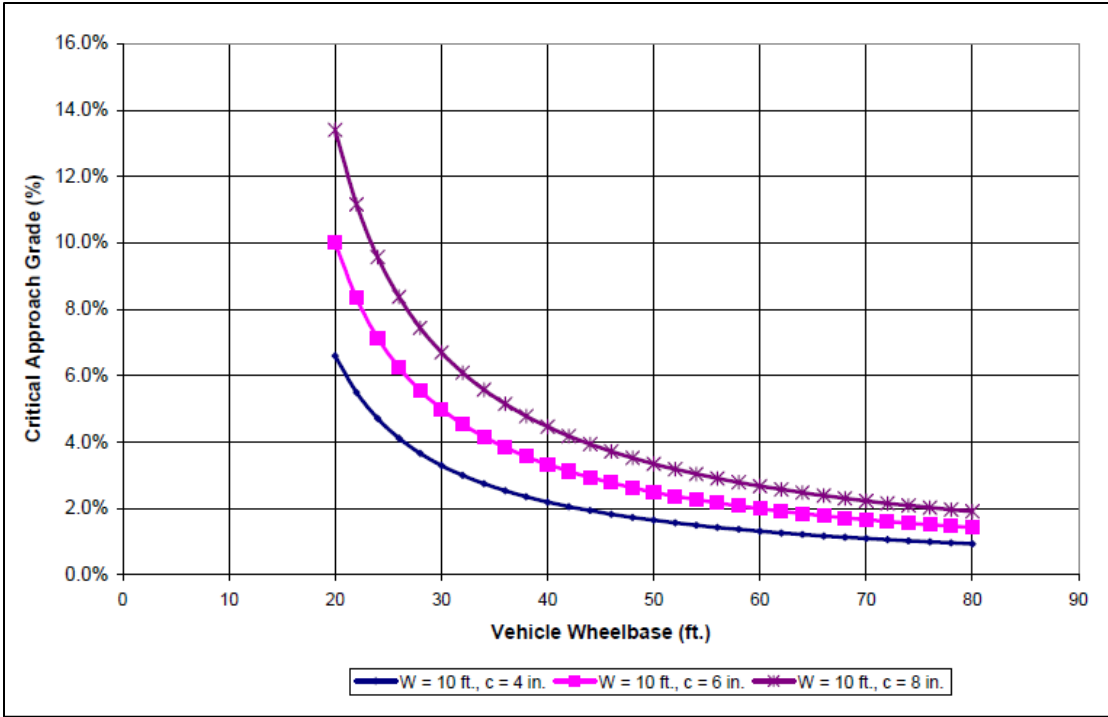

Figure 12. Critical Approach Grade vs. Wheelbase with 10 ft (3.0 m) Track Width and Various Ground Clearances [11]

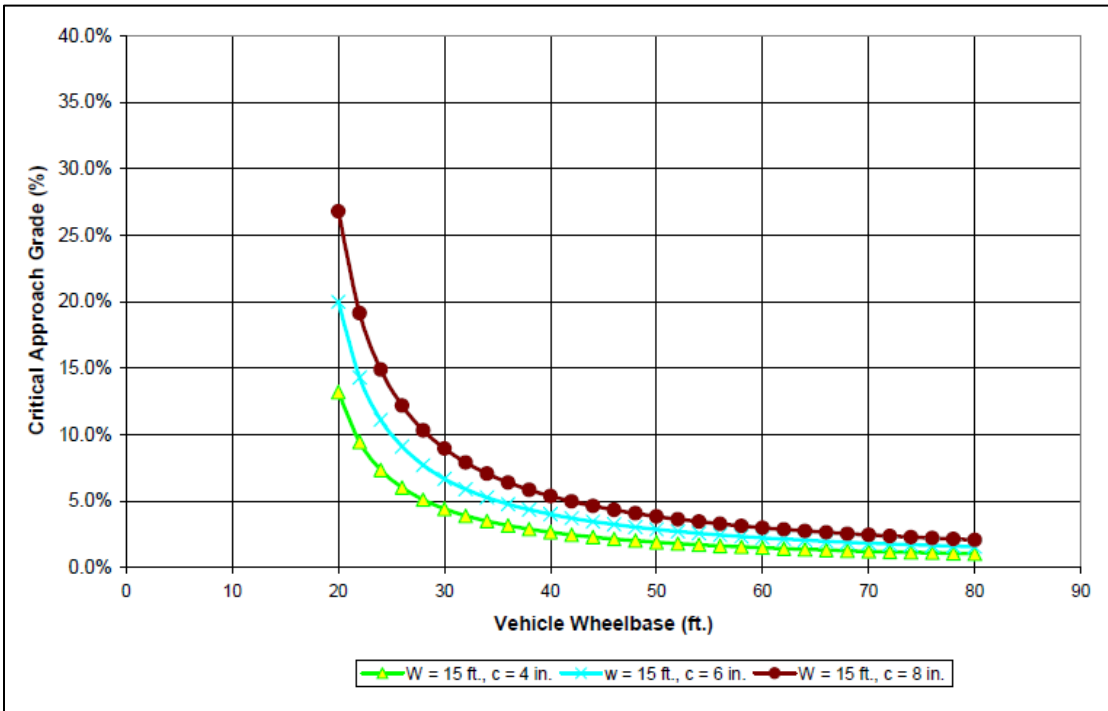

Figure 13. Critical Approach Grade vs. Wheelbase with 15 ft (4.6 m) Track Width with Various Ground Clearances [11]

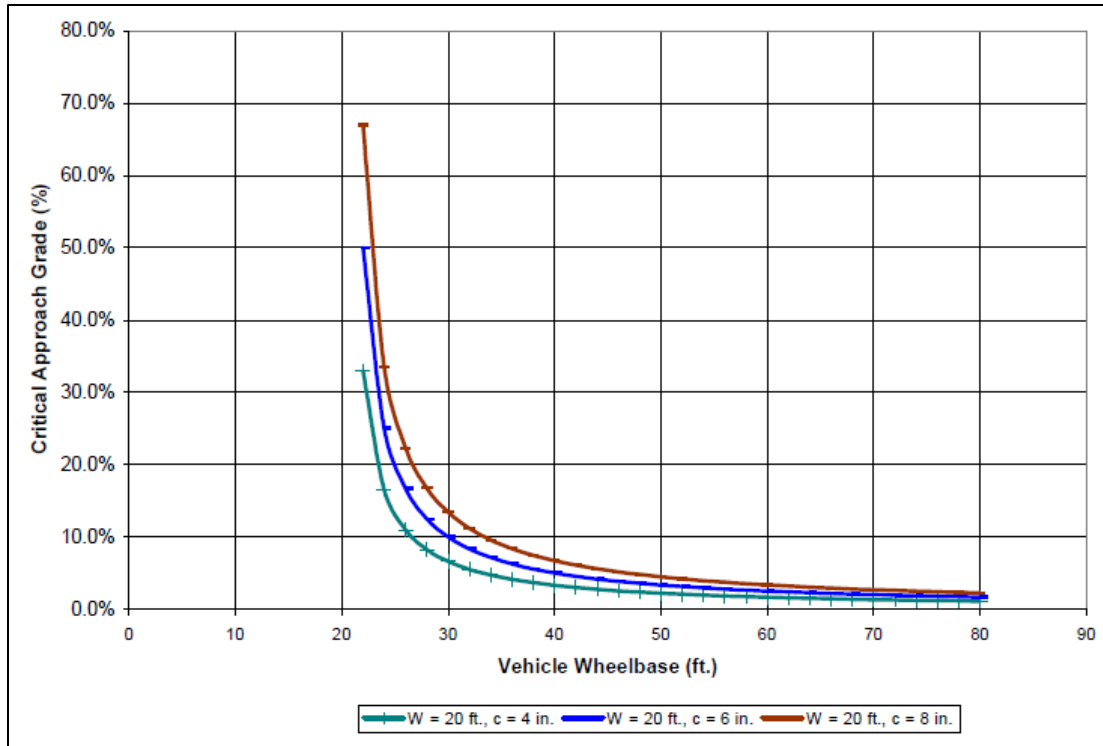

Figure 14. Critical Approach Grade vs. Wheelbase with 20 ft (6.1 m) Track Width and Various Ground Clearances [11]

### 2.7.7 Review of Hump Crossings in Florida

To determine the cause of hump crossings, FDOT utilized its Railroad Highway Crossing Inventory (RHCI) database to collect data on crossings in Florida which had low ground clearance warning signs posted or were prone to high-centering low ground clearance vehicles. Out of the forty-four crossings found, all had asphalt buildup, which suggested maintenance work performed by the railroad company. Three of the forty-four crossings had vertical sag curves. Thus, vehicles becoming stuck from front or rear overhang would be less common than vehicles becoming high-centered within the wheelbase.

### 2.7.8 Network Route Based on Crossing Profiles

In order to map the crossings in Tallahassee, Florida, FDOT utilized FRA data to identify crossings, then used Environmental Systems Research Institute (ESRI) software to find the location of each crossing. Next, the information was superimposed on a GIS base map, as shown

in Figure 15. A high-centering potential rating was established for each grade crossing, which would aid in establishing safe routes for low ground clearance vehicles, as shown in Figure 16. In addition, links to grade crossing photos and aerial photos were accessible on the map, as shown in Figure 17.

A nationwide highway-rail grade crossing map with low clearance vehicle ratings and crossing photos would be a useful tool for trucking companies and oversize/overweight load permit issuing agencies. In order to implement such a map, accurate crossing information would need to be collected and low clearance vehicle ratings would need to be established.

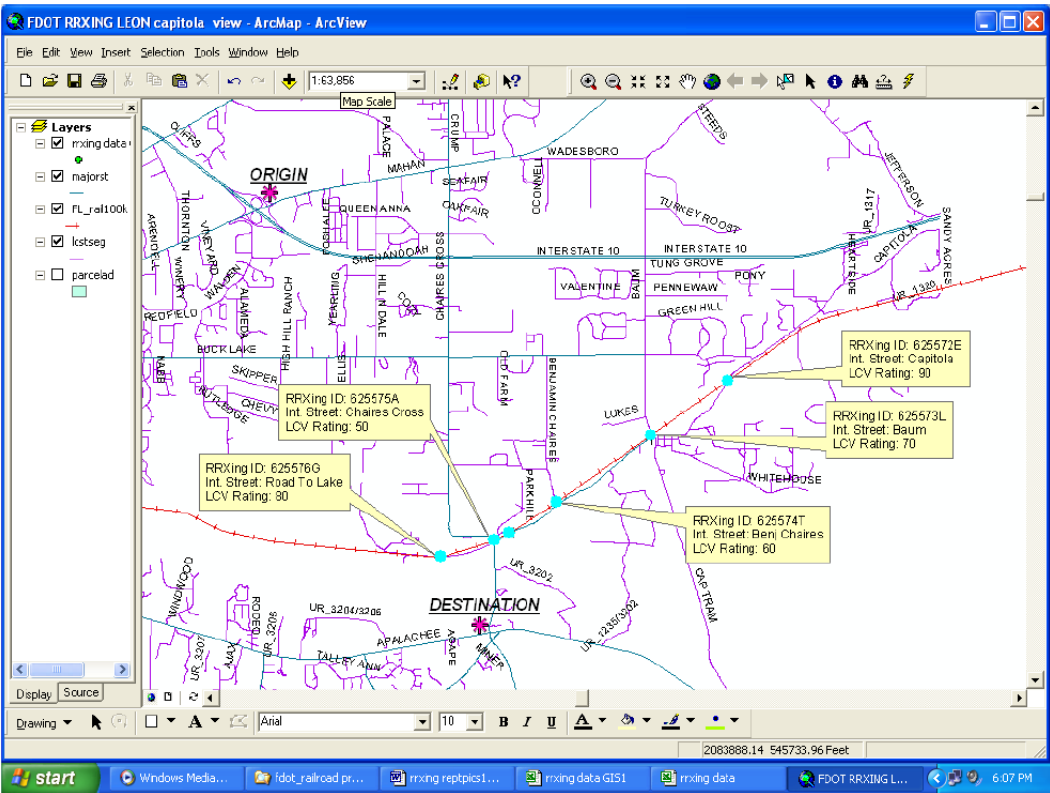

Figure 15. Railroad Crossing Map with Crossing Identification and Information [11]



## **2.8 Low-Clearance Vehicles at Rail-Highway Grade Crossings**

West Virginia University performed a study regarding low ground clearance vehicles at grade crossings in 1991 [4]. The main objectives of the study were to identify categories of vehicles with low ground clearance and to develop a computer program to evaluate the potential for vehicles to become high-centered at grade crossings.

### **2.8.1 Vehicle Classification**

A vehicle classification count was collected on Interstate 79 (I-79) in West Virginia in May 1990. Double-drop low-bed equipment trailers, boat transporters, automobile transporters, and double-drop livestock trailers were identified as low clearance trucks, and a ground clearance of 2 in. (51 mm) was the lowest seen. It was determined that low-clearance vehicles account for 2.0 percent of the traffic stream. Wheelbase and ground clearance data were collected at two additional locations in West Virginia along I-79. Collected ground clearance and wheelbase data is shown in Table 2.

Table 2. Ground Clearance and Wheelbase Data Collected in West Virginia [4]

Ground Clearance in. (mm)	Wheelbase ft (m)
9.5 (241)	31.6 (9.6) 43.8 (13.4)
9 (229)	29.7 (9.1) 30.7 (9.4) 35.0 (10.7)
8.5 (216)	35.5 (10.8)
8 (203)	27.6 (8.4) 32.4 (9.9) 32.5 (9.9) 37.5 (11.4) 40.0 (12.2) 40.8 (12.4)
7.25 (184)	33.4 (10.2)
7 (178)	26.6 (8.1) 28.9 (8.8) 32.7 (10.0) 34.8 (10.6) 35.5 (10.8) 38.0 (11.6) 38.4 (11.7)
6.75 (171)	28.8 (8.8) 33.6 (10.2)
6 (152)	28.2 (8.6) 29.5 (9.0) 29.9 (9.1) 30.5 (9.3) 31.3 (9.5) 31.4 (9.6) 33.5 (10.2)
5.75 (146)	26.0 (7.9)
5.5 (140)	28.5 (8.7) 30.0 (9.1) 31.8 (9.7) 35.0 (10.7)
5 (127)	31.1 (9.5) 34.6 (10.5)
4.75 (121)	35.0 (10.7) 38.8 (11.8)
4.5 (114)	30.6 (9.3) 32.5 (9.9)
4 (102)	31.8 (9.7)
3 (76)	36.0 (11.0)

### 2.8.2 Computer Program: HANGUP

A computer program, HANGUP, was developed to simulate low-clearance vehicles traversing grade crossings. The program can run in either manual or automatic mode. Manual mode can be utilized when specific wheelbase and ground clearance values need to be evaluated at a crossing. The output of a manual-mode simulation is shown in Figure 18. The arrows indicate points where a vehicle would become high-centered. To determine which combination of wheelbase and ground clearance values will cause high-centering over a crossing, automatic mode can be used. It will test wheelbases from 10 to 40 ft (3.0 to 12.2 m) in 1 ft (0.3 m) increments and ground clearances from 1 to 10 in. (25 to 254 mm) in 1 in. (25 mm) increments. The output of an automatic-mode simulation is shown in Figure 19. Results are given in binary code, where a high-centering incident is signified by a 1 and a safe crossing is signified by a 0.

The HANGUP program has many limitations. It is a 2D modeling program that does not take vehicles' dynamic factors into consideration. In addition, the program only accepts integer values. For ground clearance, rounding to the nearest whole inch could give an incorrect result.

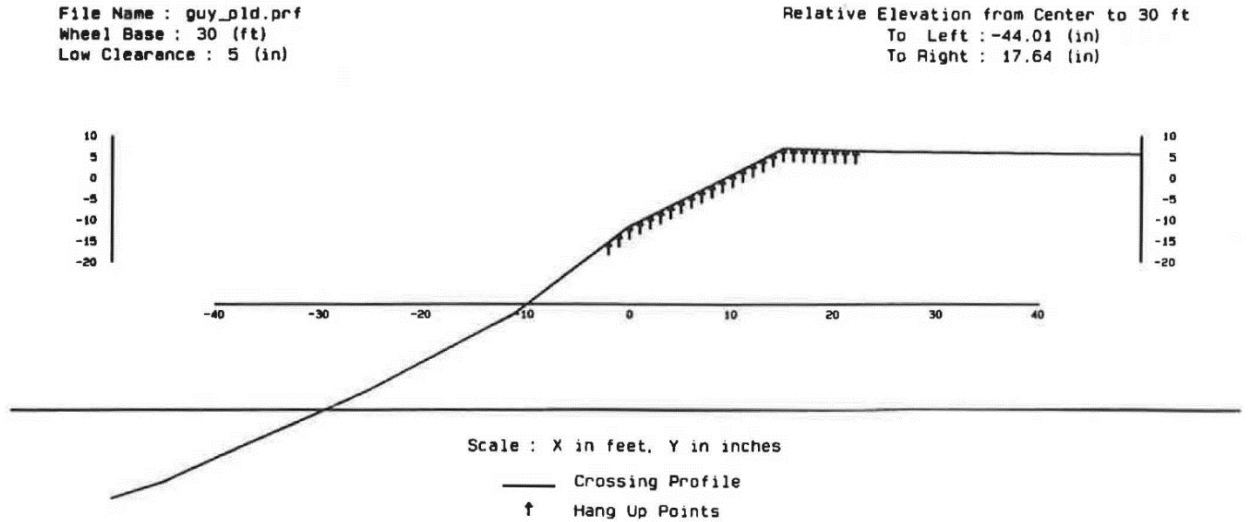

Figure 18. HANGUP Manual Mode Output [4]



H A N G U P

File Name : a:guy\_old.prp                      Date : 07-24-1990

		Ground Clearance (in)									
Wheel Base		1	2	3	4	5	6	7	8	9	10
10	(ft)	1	1	1	0	0	0	0	0	0	0
11	(ft)	1	1	1	0	0	0	0	0	0	0
12	(ft)	1	1	1	0	0	0	0	0	0	0
13	(ft)	1	1	1	1	0	0	0	0	0	0
14	(ft)	1	1	1	1	0	0	0	0	0	0
15	(ft)	1	1	1	1	0	0	0	0	0	0
16	(ft)	1	1	1	1	1	0	0	0	0	0
17	(ft)	1	1	1	1	1	0	0	0	0	0
18	(ft)	1	1	1	1	1	0	0	0	0	0
19	(ft)	1	1	1	1	1	1	0	0	0	0
20	(ft)	1	1	1	1	1	1	0	0	0	0
21	(ft)	1	1	1	1	1	1	0	0	0	0
22	(ft)	1	1	1	1	1	1	1	0	0	0
23	(ft)	1	1	1	1	1	1	1	0	0	0
24	(ft)	1	1	1	1	1	1	1	0	0	0
25	(ft)	1	1	1	1	1	1	1	1	0	0
26	(ft)	1	1	1	1	1	1	1	1	0	0
27	(ft)	1	1	1	1	1	1	1	1	0	0
28	(ft)	1	1	1	1	1	1	1	1	1	0
29	(ft)	1	1	1	1	1	1	1	1	1	0
30	(ft)	1	1	1	1	1	1	1	1	1	1
31	(ft)	1	1	1	1	1	1	1	1	1	1
32	(ft)	1	1	1	1	1	1	1	1	1	1
33	(ft)	1	1	1	1	1	1	1	1	1	1
34	(ft)	1	1	1	1	1	1	1	1	1	1
35	(ft)	1	1	1	1	1	1	1	1	1	1
36	(ft)	1	1	1	1	1	1	1	1	1	1
37	(ft)	1	1	1	1	1	1	1	1	1	1
38	(ft)	1	1	1	1	1	1	1	1	1	1
39	(ft)	1	1	1	1	1	1	1	1	1	1
40	(ft)	1	1	1	1	1	1	1	1	1	1

1 -> Hang up,    0 -> Safe

Figure 19. HANGUP Automatic Mode Output [4]

**2.9 Identification of Hump Highway-Rail Crossings in Kansas**

In 1997, the FHWA adopted the W10-5 low ground clearance sign. States are required to keep hump crossing information in an electronic database and are responsible for posting W10-5 signs at hump crossings, but the FHWA did not set a standard procedure for identifying hump crossings.

The Kansas Department of Transportation (KDOT) performed a study to identify and rank hump crossings across the state [18]. Another objective of the study was to identify characteristics of vehicles in Kansas most susceptible to becoming high-centered at grade crossings. The study did not identify or evaluate countermeasures to vehicles becoming high-centered at grade crossings.

### **2.9.1 Surveys**

Surveys were sent to each county in the state of Kansas by KDOT to gather information related to highway-rail grade crossing incidents where vehicles became high-centered on the crossing, types of vehicles which have become or are likely to become high-centered on crossings, actions taken to mitigate the issue of vehicles becoming high-centered on crossings, and involvement of railroad companies in solving the issue of vehicles becoming high-centered on crossings. The results are discussed in Section 2.9.1.1.

Surveys were also sent to each U.S. state to gather information related to procedures for identifying high-profile crossings, actions taken to mitigate the issue of vehicles becoming high-centered on crossings, identification of vehicles which have become or are likely to become high-centered on crossings, involvement of railroad companies in solving the issue of vehicles becoming high-centered on crossings, and considerations for high-profile crossings in the state's highway design manual. The results are discussed in Section 2.9.1.2.

#### **2.9.1.1 Kansas County Surveys**

A survey regarding hump crossings was sent to every county in Kansas, and seventy-nine out of one hundred-five responded [18]. Ten counties responded that they had experienced a total of forty-eight high-centering incidents in the past two years. It was not specified if any of these forty-eight incidents resulted in a crash between a train and the vehicle. Crossing profile data and vehicle data were known for one incident. Out of the sixty-six counties that reported no incidents of vehicles becoming high-centered on crossings in the last two years, thirty-four reported they have crossings with the potential to cause high-centering. Various methods of mitigating the high-centering problem were reported by fifty-nine counties: close the road over the crossing, restrict certain vehicles from using the crossing, post warning signs at the crossing, and reconstruct approaches to the crossing. When asked about railroad company involvement in correcting

potential high-profile crossings, forty-nine out of fifty-nine counties reported they were dissatisfied. Thirty-four counties were willing to participate in a study to identify hump crossings.

### **2.9.1.2 State Surveys**

A survey regarding hump crossings was sent to each state DOT and thirty-four responded [18]. State DOTs use a variety of methods to classify high-profile crossings:

- Formal Reports (crash, employee, public, police, and railroad)
- Surveys
- Inspections (routine, scrape mark, and service)
- Databases

All states are required to keep crossing databases, and nine out of thirty responding states had information in their databases that could be utilized to identify high-profile crossings. When asked if data was reflective of current conditions, states reported anywhere from continuously updated to last updated twenty years ago.

Methods for mitigating the hump crossing problem reported by the states include:

- Reconstruction
- Closure
- Signage

Where forty-nine out of fifty-nine counties in Kansas were dissatisfied with railroad company aid in solving hump crossing problems, twenty out of thirty-one states were satisfied. Out of thirty responding states, seventeen states have highway-rail grade crossing guidelines or standards in their highway design manuals which prevent design of high-profile crossings. Many of these states have adopted the AASHTO railroad-highway grade crossing guidelines, or have adopted these guidelines with some modifications.

### 2.9.2 Low Ground Clearance and Long Wheelbase Physical Model

KDOT created a physical model to evaluate hump crossings, shown in Figure 20. The model can be adjusted to represent a vehicle with a wheelbase up to 30 ft (9.1 m) and a ground clearance from zero to several inches. Bike tires were utilized for the model, in addition to a leaf spring suspension system and a truss frame structure.

To evaluate the accuracy of the physical model, it was compared against a lowboy trailer with the same wheelbase and ground clearance. Both the model and the tractor-trailer were driven over the same crossing, but on different days. The crossing was located on an unpaved road, which was graveled and graded after the lowboy trailer measurements were taken and before the model measurements were taken. It was concluded that the model measurements were comparable to those for the trailer, and if the crossing had not been changed, the model and trailer would have yielded the same results. Furthermore, the model measurements were much easier and quicker to obtain.



Figure 20. Physical Model Built for Evaluation of Crossings in Kansas Study [18]

### 2.9.3 HANGUP Program

Kansas utilized HANGUP version 2.4, the program created by West Virginia University discussed in Section 2.8.2, to evaluate large trucks and trailers becoming high-centered at grade crossings. The program inputs are the crossing profile data and the vehicle dimensions. The necessary vehicle dimensions are wheelbase, ground clearance between the axles, front and rear overhang, and front and rear ground clearances. The program will output one of three results: safe (0), hang-up (1), or more detailed study warranted (\*). A result of “more detailed study warranted” is output when the clearance between the crossing profile and vehicle models is less than 1 in. (25 mm).

A 3D version of the HANGUP software became available during the Kansas study, but the researchers were never able to run the program successfully. Therefore, the 2D version was used to evaluate sixteen crossings in Kansas with three critical vehicles: a school bus, a cattle trailer, and a lowboy trailer. The dimensions for each critical vehicle are shown in Table 3, and were taken when each vehicle was unloaded. Out of the forty-eight simulations run, six resulted in high-centered vehicles and the remaining forty-two were deemed safe.

Table 3. Critical Vehicle Dimensions for Kansas Study [18]

Vehicle Type	Wheelbase ft (m)	Ground Clearance in. (mm)
School Bus	21 (6.4)	22 (559)
Cattle Trailer	37 (11.3)	12.5 (318)
Low-Boy Trailer	33 (10.1)	11.17 (284)

### 2.9.4 Kansas Crossing Database

During this study, KDOT updated the state grade crossing inventory. Every public grade crossing in the state was surveyed, and sixty data items were collected at each crossing. While collecting crossing data, the surveyors also identified 250 high-profile crossings by looking for

scratch or gouge marks on the crossing, or crossings with a grade of 9.4 or greater on either approach slope. The value of 9.4 was arbitrarily chosen. Around half of the crossings with grades greater than 9.4 had scratch or gouge marks.

For these 250 high-profile crossings, grade data was collected using a rod and level along the centerline and both edges of the pavement. Elevations were taken from each track to 100 ft (30.5 m) out, every 5 ft (1.5 m) for the first 30 ft (9.1 m), and then every 10 ft (3.0 m).

## 2.10 Highway-Rail Grade Crossing Crashes with High-Centered Vehicles

While not all vehicles high centered on rail grade crossings lead to a train crash, several train collisions with vehicles high centered on tracks occur every year. Thirty-three crashes involving low ground clearance vehicles and hump highway-rail crossings are summarized in the following sections.

### 2.10.1 Crash between Metrolink Train and Tractor-Trailer

On January 28, 2000 a tractor-trailer combination vehicle transporting an oil refinery condenser unit was impacted by a Metrolink commuter train in Glendale, California [19]. The tractor was a 1997 Peterbilt model. The trailer was a 1992 Aspen semi-trailer with two 2-axle boosters and a 3-axle lowboy semi-trailer equipped with a hydraulic lift, as shown in Figure 21. The tractor-trailer unit was 135 ft (41.1 m) long, had a ground clearance of 6 in. (152 mm), and had a gross weight of 226,000 lb (102,512 kg). The oil refinery condenser was valued at \$1.5 million and its transportation required permits from four states.

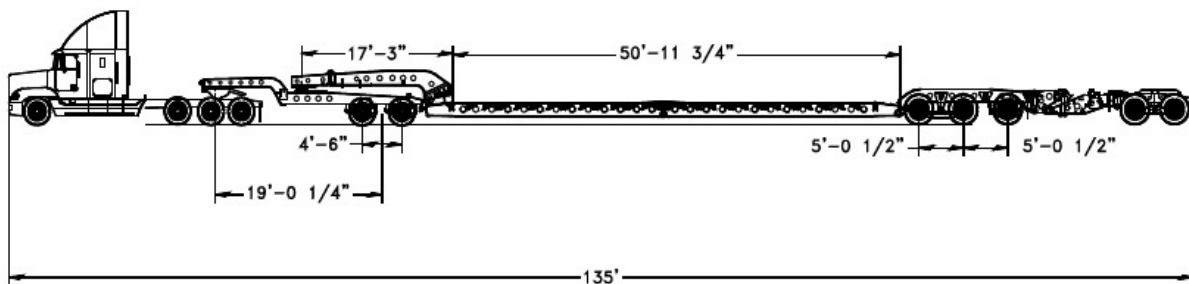

Figure 21. 1997 Peterbilt Tractor and 1992 Aspen Semi-trailer Combination Unit [19]

The transport convoy consisted of two pilot cars, three California Highway Patrol (CHP) officers, and the truck driver. The lead pilot car driver had received the permitted route for each state and compiled the directions onto one handwritten sheet. While he was transcribing the complete route, the pilot car driver mistakenly missed some directions. In addition to missing directions, the lead pilot car driver and truck driver had been awake for 27 and 22 hours, respectively. These two factors contributed to the crash.

In the town of Glendale, the tractor-trailer unit followed the pilot car over the Grandview Avenue crossing, missing the turn before the crossing onto San Fernando Road. The Grandview Avenue crossing, with USDOT grade crossing number 746796L, consisted of two sets of tracks spaced 20 ft (6.1 m) apart with a grade of 3.26 percent on the south side and 3.02 percent on the north side. According to the 2011 AASHTO guidelines for railroad-highway grade crossings [8], the Grandview Avenue crossing should have been classified as a high-profile or hump crossing, as shown in Figure 22. Therefore, no low-ground clearance warning signs were present at the crossing, which could have prevented the crash.

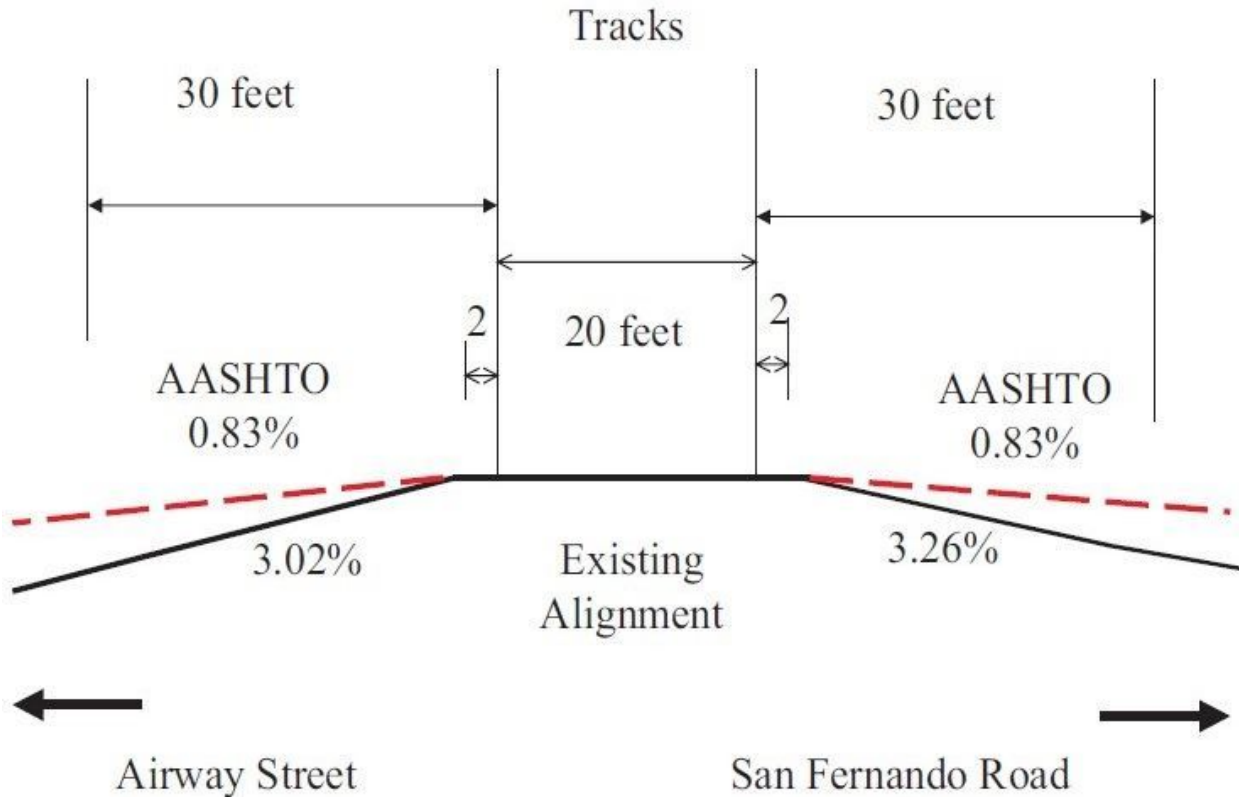

Figure 22. Grandview Avenue Crossing Diagram [19]

While the truck was crossing the tracks, one of the CHP officers observed the trailer scraped the surface of the crossing. The truck driver did not feel his trailer bottom out and the officer neglected to tell anyone. After crossing the tracks, the pilot car driver realized he had missed the correct turn and the convoy decided to circle the block and re-cross the tracks to return to San Fernando Road. While crossing the tracks for the second time, the trailer became lodged on the crossing. The driver exited the cab and began using the hydraulic lift. Around 60 seconds after becoming lodged on the tracks, the railroad warning devices activated. When the truck driver noticed the warning devices, he returned to the cab and managed to move the truck forward a few inches before the train struck.

Before the crash, the train engineer noticed the tractor-trailer high-centered on the tracks, sounded the horn, and applied the brakes 1,000 ft (304.8 m) before the crossing. Nonetheless, the



train collided with the trailer. After the crash, the train engineer warned another oncoming train about the obstruction and prevented a second crash.

Total damages were around \$2,274,000 and minor injuries occurred to the train engineer, train conductor, and four train passengers. The train experienced significant damage to the engine, as well as minor damage to the coaches. In addition, the warning devices on the north side of the road were destroyed, the impacted trailer separated into three parts, and the oil refinery condenser was destroyed, as shown in Figure 23. The railroad tracks and tractor received no damage.



Figure 23. Oil Refinery Condenser Unit and Train [19]

### **2.10.2 O&J Trucking Company Crash**

On May 2, 1995 an unloaded tractor-trailer combination unit owned by O&J Trucking Company became lodged on a hump railroad crossing near Sycamore, South Carolina and was later hit by Amtrak Train No. 81 [5].

The overall length of the tractor-trailer unit was 61 ft (18.6 m) and it was a combination of a 1986 Freightliner 3-axle conventional tractor and a 48 ft (14.6 m) long 1994 Evans 2-axle lowboy semi-trailer. The trailer had an unloaded ground clearance of 12 in. (305 mm). At the time of the crash, the trailer stands protruded 3 in. (76 mm) below the bottom of the semi-trailer.

To return home after a delivery, the driver had to traverse a hump railroad crossing located on an unpaved road known to locals as Boogaloo Road. The crossing had 5.28 percent and 9.97 percent grades on either side, has USDOT grade crossing number 634810U, and is shown in Figure 24. No hump crossing warning signs were posted. The truck driver had traversed this crossing before, but never with a trailer as low as the one involved in the crash.



Figure 24. Boogaloo Crossing [5]

As he was crossing the tracks, the driver heard a scraping sound and the truck suddenly stopped. Upon inspection, the driver failed to observe that the trailer stands had become embedded in the asphalt. The driver attempted to free the trailer, but was unable to get the truck to move and when he attempted to contact the carrier's office to warn them he was high-centered on the tracks, the office was closed and no one answered.

The train engineer and assistant engineer both saw the semi-trailer on the tracks, applied the emergency brakes, and braced for impact. The force of the impact separated the tractor from the trailer and derailed both locomotives and fourteen of the sixteen cars. Total damages were approximately \$1,282,500 and thirty-three train personnel and passengers received minor injuries.

### **2.10.3 Highway-Rail Grade Crossing Collision Report Summary**

Appendix E of the *Highway/Rail Grade Crossing Collision near Sycamore, South Carolina May 2, 1995* report [5], summarized in Section 2.10.2, features summaries of fifteen other truck-train crashes in which a tractor-trailer unit became lodged on a railroad crossing.

Case no. 1 discusses a crash that occurred on August 25, 1983 in Rowland, North Carolina that resulted in twenty-nine injuries and \$623,399 worth of damage. The truck, trailer, and cargo had a gross weight of 105,820 lb (47,999 kg). The trailer ground clearance was 7 in. (178 mm) and the distance between the kingpin and first semi-trailer axle was 36 ft – 4 in. (11.1 m). The North Carolina permit allowed 103,000 lb (46,720 kg), therefore the driver was instructed to avoid scales. This resulted in him deviating from his authorized route and becoming lodged on a hump crossing. He attempted to raise the semi-trailer with the hydraulic lifts but was unsuccessful. The train engineer saw the truck on the tracks and applied the emergency brake about 1,200 ft (365.8 m) before the crossing. The crash separated the tractor from the trailer and derailed the train.

Case no. 2 summarizes a crash that occurred on November 30, 1983 near Citra, Florida that resulted in fifty-nine injuries and \$200,119 worth of damage. The truck was transporting earth-moving equipment, and together with the trailer, had a gross weight of about 150,000 lb (68,039 kg). The trailer's ground clearance was 9.5 in. (241 mm). The distance between the kingpin and the trailer's first axle was 31 ft – 9 in. (9.7 m).

The crossing had a 3 percent ascending grade east of the track and a 4 percent descending grade west of the track, each calculated from the centerline of the track to 100 ft (30.5 m) in either direction. The truck was high-centered on the tracks for about fifteen minutes before the crash, during which the driver unsuccessfully attempted to lift the trailer off the tracks by using the hydraulic lift. The train engineer, having seen the trailer high-centered on the tracks, reduced the

train speed to 35 mph (56.3 km/h) when they collided. The tractor separated from the semi-trailer and the locomotive and four cars derailed.

Case no. 3 summarizes a crash that occurred on September 4, 1985 in Donner, Louisiana that resulted in \$40,000 worth of damage and zero injuries. The tractor-trailer was transporting a bulldozer when it became lodged on the Deadwood Road crossing, which had a 5.8 percent descending grade on one side and a 13.5 percent ascending grade on the other, with respect to the truck and trailer travel direction. The trailer had a ground clearance of 8 in. (203 mm) and the distance between the rear tractor axle and the first semi-trailer axle was 28 ft (8.5 m). The truck driver unhitched the tractor, unloaded the bulldozer, and attempted to move the trailer with the bulldozer when the train struck. The train had slowed to 40 mph (64.4 km/h) before colliding with the trailer, which struck the pickup truck.

Case no. 4 occurred on October 30, 1986 in Gary, Indiana and resulted in thirty-two injuries and \$110,000 worth of damage. The tractor-trailer was transporting a 38,190 lb (17,323 kg) steel coil when it became lodged on the tracks. The trailer had a ground clearance of 8 in. (203 mm) and a distance of 31 ft – 9 in. (9.7 m) between the kingpin and first trailer axle. The driver reported that the drive shaft snapped as he was dragging the trailer over the crossing. In the ten minutes before the train collided with the trailer, the truck driver cleared traffic to make room for another truck that was following him, and they were going to attempt to pull the trailer off the crossing. Before the other truck arrived, the warning devices activated and the train collided with the trailer.

The trucking company chose to traverse this crossing to avoid the Steelworker's Union picket line, even though they recently had problems clearing it. Consequently, the truck was equipped with a radio to contact the carrier's office if necessary, but it was inoperative at the time of the crash.

Case no. 5 summarizes a crash that occurred on November 12, 1986 in College Park, Georgia that was caused by the truck driver missing a sign prohibiting trucks longer than 30 ft (9.1 m) from using the crossing. The trailer had 10 in. (254 mm) of ground clearance and the distance between the kingpin and first trailer axle was 31 ft (9.4 m). For the twenty minutes before the crash, the truck driver attempted to contact a tow truck via radio, but did not try to contact police or the railroad. When he saw the train headlights, he ran along the tracks, trying to warn the train. The engineer saw the truck high-centered on the tracks and applied the emergency brakes about 900 ft (274 m) before the crossing. The train did not derail after colliding with the lodged tractor-trailer. The crash resulted in zero injuries and \$90,000 worth of damage.

Case no. 6 occurred in Winlock, Washington on December 22, 1986 and resulted in three injuries and \$252,000 worth of damage. This crossing had a 14 percent ascending grade on the west side which transitioned to a 5 percent ascending grade 5 ft (1.5 m) from the tracks. The semi-trailer had a ground clearance of 12 in. (305 mm) and the crash occurred two and a half minutes after becoming lodged on the tracks. The semi-trailer was torn into two pieces, and two locomotives and four coach cars derailed.

Case no. 7 summarizes a crash that occurred on January 15, 1987 near Canby, Oregon and resulted in one injury and \$49,022 worth of damage. The tractor-trailer unit was transporting crane parts and had a ground clearance of 7.75 in. (197 mm). A 12.6 percent ascending grade for 3 ft (0.9 m) east of the tracks transitioned into a 5.8 percent ascending grade for the next 40 ft (12.2 m), and the other side had a 3.2 percent descending grade. The crash caused the second locomotive to derail and the crane parts to fall off the trailer, while the lead locomotive pushed the truck 400 ft (121.9 m) down the track.

Case no. 8 occurred in Halifax, North Carolina on November 12, 1987 and resulted in \$266,130 worth of damage and zero injuries. The tractor-trailer unit was transporting a Caterpillar

excavator when it became lodged on the tracks. The train engineer saw the truck and applied the emergency brakes, slowing the train down to 50 mph (80.5 km/h) when it collided with the trailer. The crash caused the locomotive and eight cars to derail, as well as extensive damage to the track, semi-trailer, and excavator.

Case no. 9 summarized a crash that occurred on November 25, 1987 in Seffner, Florida that resulted in seventeen injuries and \$336,349 worth of damage. The tractor-trailer was transporting a backhoe when it became lodged on the tracks. The loaded ground clearance of the trailer was 5.25 in. (133 mm). The train engineer noticed the truck stopped on the tracks and applied the emergency brakes. The crash damaged the tractor, destroyed the semi-trailer and backhoe, and caused the locomotive, baggage car, and a sleeping car to derail.

Case no. 10 describes a crash that occurred on October 3, 1990 in Encinitas, California that resulted in thirteen injuries and \$285,000 worth of damage. An auto-transport trailer, with a ground clearance of 7.5 in. (191 mm), became lodged on the Leucadia Boulevard crossing, after the driver failed to see a sign prohibiting trucks. The approach grade to the east of the tracks had a 2 percent ascending grade, and the departing slope to the west of the tracks had a 9 percent descending grade. The train engineer applied the emergency brakes about 1,000 ft (304.8 m) before the crossing and the train collided with the auto-transport trailer at 65 mph (104.6 km/h). The impact severed the semi-trailer, causing five vehicles to be torn from it, two of which were destroyed, and three vehicles remained on the trailer undamaged. In addition, the cab control car derailed and was damaged substantially.

Case no. 11 summarizes a crash in East Patchogue, New York on May 11, 1992 that resulted in \$173,837 worth of damage and twenty-eight injuries. A tractor-trailer unit, with a ground clearance of 7 in. (178 mm), was transporting four concrete sewer vaults when it became lodged on a crossing with a 4 percent ascending grade on one side and a 0.3 percent descending

grade on the other. The train engineer applied the emergency brakes about 600 ft (182.9 m) before the crossing and slowed the train to 45 mph (72.4 km/h) when it struck the semi-trailer. The lead locomotive derailed and was extensively damaged and two of the concrete sewer vaults shattered.

Case no. 12 described a crash between a tractor-trailer and a train on June 30, 1992 near Orange Park, Florida that resulted in zero injuries and \$169,000 worth of damage. The semi-trailer, which had a ground clearance of 14 in. (356 mm) became lodged on a railroad crossing with a 7.3 percent descending grade on the approach slope and 5.3 percent ascending grade on the departure slope. The train engineer applied the emergency brakes and collided with the semi-trailer, which fractured into two pieces. The train did not derail after impact.

It should be noted that the railroad dispatch office was contacted by the police and notified of the lodged truck. Unfortunately, another call was made by a citizen, who gave the incorrect location, and the mistake was not caught by either the police or dispatch office. This resulted in a police officer traveling to the incorrect location and declaring the crossing clear, and the train was given permission to move.

Case no. 13 summarized a crash on November 30, 1993 in Intercession City, Florida that resulted in fifty-nine injuries and \$14,000,000 worth of damage. A 184 ft (56.1 m) long tractor-trailer unit, consisting of thirteen axles, was transporting a turbine generator, as shown in Figure 25. When the trailer was about halfway across the tracks, it had to be stopped and raised to clear the crossing. This left the cargo deck and turbine over the tracks for about seven minutes. During this time, the supervisor on scene tried to contact the trainmaster and the railroad, but his calls were unanswered. The train collided with the trailer at 54 mph (86.9 km/h) after the emergency brakes were applied. The lead locomotive and four cars derailed and eventually overturned, receiving extensive damage. In addition, the turbine generator, transport vehicle, and track were destroyed.

A NTSB highway accident report [20] summarized this crash in more detail. The crossing was analyzed after the crash and was found to be out of compliance with the AREMA and AASHTO guidelines. In addition, Florida law requires low ground clearance vehicles to notify railroad companies before attempting to traverse grade crossings. This requirement was not voiced to the convoy operators when they acquired the permit, and therefore the railroad company was not notified. Both factors contributed significantly to the crash.

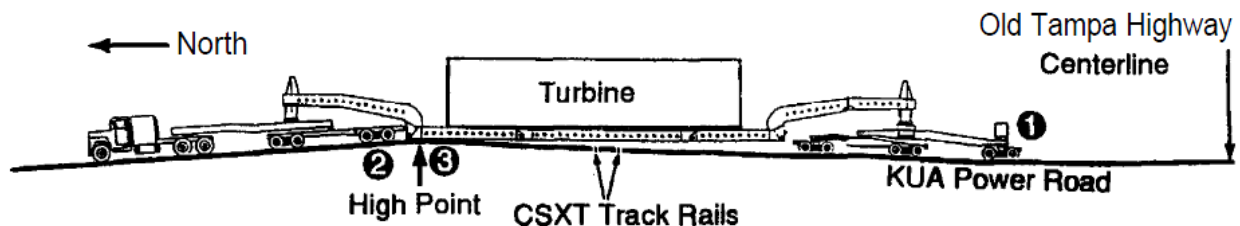

Figure 25. Tractor-Trailer Unit Transporting a Turbine in Intercession City, Florida [20]

Case no. 14 summarized the crash at Boogaloo Road, described in Section 2.10.2. Case no. 15 describes a crash that occurred on May 10, 1995 in Graysville, Georgia that resulted in one injury and \$1,000,000 worth of damage. The truck was transporting a backhoe when it became lodged on the crossing, which had a 3 percent ascending grade on the approach slope and an 8 percent descending grade on the departure slope. About a minute after becoming high-centered, a county sheriff arrived on scene and kept traffic clear of the area. The sheriff contacted his dispatcher, who in turn contacted the railroad, but there was no time to stop the train. The truck driver and his passenger were unable to move the tractor-trailer off the tracks, and five to ten minutes after becoming lodged, the train collided with the trailer, destroying the backhoe and transport vehicle.

Case no. 16 describes a crash in Milford, Connecticut that occurred on October 3, 1995 and resulted in twenty-four injuries and \$500,000 worth of damage. A tractor-trailer combination unit was transporting an excavator and traveling an unauthorized route when it became lodged on



a hump crossing. The crossing had a 9.1 percent ascending grade on one side and a 3.7 percent descending grade on the other. In the three minutes before the train collided with the lodged vehicle, the truck driver attempted to raise the semi-trailer by using the hydraulic ram on the gooseneck, but was unsuccessful. The crash separated the tractor from the semi-trailer and the lead train car pushed the excavator off the semi-trailer. A crossing identification number was posted at the crossing but the truck driver did not attempt to contact the police or the railroad.

#### **2.10.4 NTSB Investigation Nos. H-84-66 through H-84-68**

The NTSB issued safety recommendations on August 29, 1984 that resulted from two crash investigations [21]. The first crash occurred on August 25, 1983 in Rowland, North Carolina, and was summarized in Section 2.10.2. The tractor-semi-trailer unit had a wheelbase of 36 ft – 4 in. (11.1 m). It was later determined that the trailer would have required that the crossing have a radius of 283.17 ft (86.3 m) to traverse safely. The crossing involved in this crash had a curved radius of 207.30 ft (63.2 m).

The second crash occurred on November 30, 1983 in Citra, Florida, and was summarized in Section 2.10.3. The truck and trailer involved in the crash were not overloaded, the trailer did not have any mechanical defects, and the driver was following the prescribed route. It was later determined that county and railroad officials had not discussed maintenance of the crossing, and railroad maintenance was absent of any roadway regrading, resulting in a hazardous crossing geometry.

The NTSB concluded that, when designing or maintaining roads, adequate ground clearance and highway-rail grade must be the top priorities. Furthermore, the highway and railroad departments must communicate and coordinate when performing maintenance. In response to the crashes, FDOT created a committee to study hazardous grade crossings in January 1984. The purpose of the committee was to:

- Develop a standard design for grade crossings
- Install warning signs
- Identify highway-rail grade crossings which were non-compliant with standards
- Encourage governments to fix out of compliance crossings
- Persuade railroads to cooperate with local governments when performing maintenance
- Encourage trucking companies to inform drivers of the dangers of hump crossings

The NTSB provided three recommendations for the FHWA: H-84-66, which suggests creating a bulletin which would alert drivers of hazards at hump railroad crossings; H-84-67, which would provide the Bureau of Motor Carrier Safety divisions access to an information system that identifies all motor carriers in their jurisdiction; and H-84-68, which would create an automated management information system.

#### **2.10.5 NTSB Railroad Accident Brief**

On February 5, 1997 an Amtrak train collided with a tractor-semi-trailer combination at a grade crossing in Jacksonville, Florida [22]. The truck driver had attempted to turn around on a narrow road near the Old Kings Road tracks and became high-centered on the crossing, which caused the wheels to leave the pavement. A passing pickup truck attempted to pull the tractor-trailer wheels down to the pavement, but was unsuccessful and Amtrak train P098 collided with the high-centered semi-trailer. The crash caused the locomotive and four cars to derail and resulted in fifteen injuries and \$1,410,000 worth of damage. The tractor-semi-trailer unit was destroyed. Despite the truck having a citizens band (CB) radio and Qualcomm satellite communication system, the truck driver did not attempt to contact the police or railroad.

#### **2.10.6 Bus-Train Crash in Biloxi, Mississippi**

On March 7, 2017 a charter bus became lodged on the Main Street railroad crossing in Biloxi, Mississippi [37]. The bus was carrying forty-nine passengers when it became high-centered

on the crossing and was hit by a train. The crash resulted in four deaths and thirty-nine injuries. The bus was high-centered on the tracks for about five minutes before the train struck [38]. While attempting to traverse the crossing, the bus frame became lodged on the tracks. The bus driver opened the entry door to let passengers escape before the train struck [37]. Robert Sumwalt, an NTSB member, said the bus driver used directions from a GPS set for commercial vehicles instead of the directions given by the tour company [39]. The train was traveling at 26 mph (41.8 km/h) when the emergency brake was applied and slowed to 19 mph (30.6 km/h) when it collided with the bus, which was pushed 203 ft (61.9 m) down the track before the train came to a stop, as shown in Figure 26 [37].



Figure 26. Train and Bus in Biloxi, Mississippi Crash After the Train Came to a Stop on March 7, 2017 [40]

The Main Street crossing in Biloxi, Mississippi has seen sixteen crashes since 1976 [38]. This does not include vehicles that became high-centered on the crossing but were not hit by a train. Out of the sixteen crashes, six involved vehicles that were stopped or high-centered on the

tracks. In the past four years, three incidents have occurred at the Main Street crossing in Biloxi, Mississippi involving long, low profile vehicles.

On January 5, 2017 a Pepsi delivery truck became high-centered on the crossing and was hit by a CSX train, as shown in Figure 27 [41]. The driver left the cab before the train hit and no one else was injured. On March 12, 2016 a charter bus carrying twenty-eight passengers became high-centered on the crossing, as shown in Figure 28. The oncoming train was stopped a few blocks before the crossing to prevent a crash. On August 28, 2014 a tractor-trailer became high-centered on the crossing and was struck by a train. One railroad employee was injured in this crash.



Figure 27. Pepsi Truck after the Train Crash at the Main Street Crossing in Biloxi, Mississippi on January 5, 2017 [41]





Figure 28. Charter Bus High-Centered at Main Street Crossing in Biloxi, Mississippi on March 12, 2016 [41]

Andrew Gilich, the mayor of Biloxi, Mississippi, proposed closing six railroad crossings that had grade issues prior to the crash on March 7, 2017 [41]. Closing these six crossings would prevent vehicles from becoming high-centered as well as increase the resources available for improving the twenty-three other crossings in Biloxi.

Low ground clearance signs are posted on both sides of the Main Street crossing as shown in Figure 29, as well as bells, lights, and crossing arms [37]. The signs do not prohibit any vehicles from crossing, they only warn of the hump crossing.



Figure 29. Main Street Crossing and Low Ground Clearance Sign in Biloxi, Mississippi [37]

On March 10, 2017, three days after the bus-train crash, new warning signs were posted at the Main Street crossing in Biloxi, Mississippi [42]. Trucks, buses, and RVs are now prohibited from using this crossing, as well as crossings along three other streets in Biloxi. In addition, an emergency phone number and a crossing identification number will be posted at each crossing.

### **2.10.7 Train-to-Truck Crashes with Limited Data**

News articles were found which describe crashes in which tractor-trailer vehicles became lodged on railroad crossings. Although news feeds do not contain the engineering analysis and details which are included in reports, various crashes were identified and referenced in the following sections.

#### **2.10.7.1 Lake Worth, Florida, March 16, 1988**

An auto transport tractor-trailer carrying eight vehicles became lodged on a railroad crossing in Lake Worth, Florida on March 16, 1988 [23]. The truck driver was traveling on Washington Avenue, a road trucks were restricted from using. The crash separated the trailer into two pieces and caused \$350,000 worth of damage.

### **2.10.7.2 North Miami, Florida, March 22, 2010**

On March 22, 2010, an auto-transport trailer carrying Lexus vehicles became high-centered on a railroad crossing in North Miami, Florida, as shown in Figure 30 [24]. The crash caused two of the vehicles to fall off the trailer and tore the trailer into two pieces.



Figure 30. Tractor Separated from Auto Transport Trailer [24]

### **2.10.7.3 Hillsborough, North Carolina, March 23, 2012**

An auto-transport tractor-trailer was transporting seven vehicles in Hillsborough, North Carolina on March 23, 2012 when it became lodged on a railroad crossing [25]. The driver informed the police, who were able to contact the railroad and stop the train before a crash could occur.

#### **2.10.7.4 Westchester, New York, September 20, 2004**

An empty auto-transport trailer became lodged on a crossing in Westchester, New York on September 20, 2004 when the driver took a wrong turn onto a road which prohibited large trucks [26]. The truck was attempting to turn around on the crossing when it became lodged. This crossing had an emergency phone number posted which went to an operator in direct contact with the train conductor, but the truck driver did not attempt to call it. A train collided with the truck, and the crash resulted in twenty-nine injuries.

#### **2.10.7.5 Springdale Borough, Pennsylvania, October 23, 2013**

On October 23, 2013 an auto-transport vehicle became lodged on a railroad crossing in Springdale Borough, Pennsylvania, and a train collided with the trailer [27]. The trailer was destroyed as a result of the crash. Several trucks had been impacted by a train at the same location.

#### **2.10.7.6 Waxahachie, Texas, July 22, 2015**

An auto-transport vehicle became lodged on a crossing in Waxahachie, Texas on July 22, 2015, as shown in Figure 31 [28]. Police arrived on scene and contacted Union Pacific (UP), which alerted the train to the obstruction. In addition, the police set out flares along the track in case the railroad could not get in contact with a train. Subsequently, another truck arrived to pull the high-centered auto-transport truck off the tracks, and no train-truck crash occurred.





Figure 31. Auto-Transport Trailer High-Centered on Tracks in Waxahachie, Texas [28]

#### **2.10.7.7 Colorado Springs, Colorado, October 4, 2016**

An auto-transport truck became high-centered on a railroad crossing south of Colorado Springs, Colorado on October 4, 2016, as shown in Figure 32 [29]. The train was traveling at 3 mph (4.8 km/h) when it struck the auto-transport trailer, which resulted in minor damage to the truck and trailer, and no injuries were reported. A sign prohibiting trucks, buses, limousines, and recreational vehicles (RVs) was posted at the crossing, as shown in Figure 33, but the truck driver did not heed the warning.



Figure 32. Slow Moving Train Collided with Auto-Transport Trailer [29]



Figure 33. Sign Posted at Crossing Prohibiting Trucks, Buses, Limousines, and RVs [29]

#### **2.10.7.8 Johnston, South Carolina, May 14, 2015**

A tractor-trailer transporting a transformer was struck by a train in Johnston, South Carolina on May 14, 2015 after the truck became high-centered on the tracks [30]. The crash

destroyed the transformer, split the trailer in half, totaled multiple nearby cars, and derailed the locomotive and one empty car, but caused no injuries. One witness, who worked at a drug store near the crossing, said she had seen multiple trucks become high-centered on the crossing.

#### **2.10.7.9 Rayville, Louisiana, May 5, 2016**

On May 5, 2016 near Rayville, Louisiana a truck equipped with a lowboy trailer was transporting a large farm tractor when it became high-centered on a railroad crossing [31]. The truck driver was not traveling his permitted route when he became lodged on the tracks, and a few minutes later the train collided with the trailer, causing damage to the trailer and farm tractor, as shown in Figure 34.



Figure 34. Tractor-Lowboy Combination after the Crash [31]

#### **2.10.7.10 Kings Mountain, North Carolina, 2011-2012**

In Kings Mountain, North Carolina in November 2011, a train collided with a tractor-interstate trailer lodged on a railroad crossing, as shown in Figure 35 [32-33]. The crossing has “Low Ground Clearance” and “No Truck Crossing” signs posted, as shown in Figure 36, but the truck driver did not avert his course. The crash occurred at approximately 1:30 a.m. According to local police, seven large tractor-trailer combination vehicles had become lodged on this crossing during 2011 despite posted warning signs.





Figure 35. Interstate Semi-trailer after the Crash with the Train [32]



Figure 36. Low Ground Clearance Warning Sign Posted at Crossing [32]

On May 4, 2012, a few months after the first crash, another tractor-trailer became high-centered at an adjacent grade crossing blocks away from the first [34-35]. The tractor-trailer was carrying bundles of cotton which were scattered after the collision with a train. The collision was documented on video using a phone, and the video was posted to YouTube [36]. It was the fifth stuck tractor-trailer to be impacted by a train at that location. Shortly after this crash, the grade crossing was closed while the city council and mayor's officials determined what to do with high-slope grade crossings.



Figure 37. Second Train Crash at Kings Mountain, North Carolina [35]

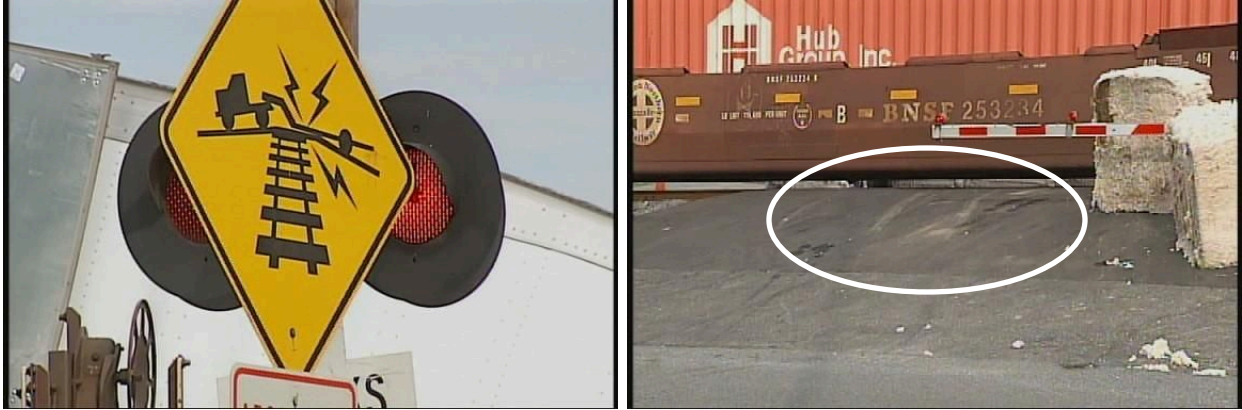

Figure 38. Rail Grade Crossing Warning and Scrape Marks at Grade Crossing [35]

#### **2.10.7.11 Halifax, North Carolina, March 9, 2015**

An oversized flatbed trailer was transporting a modular building when it became high-centered on a railroad crossing in Halifax, North Carolina on March 9, 2015 [7]. The trailer was straddling the railroad tracks, attempting to make a left-hand turn, when the warning devices activated. The train collided with the trailer. The locomotive and two cars derailed and fifty-five people were injured.

## **3 SPEED TABLE TESTING**

### **3.1 Introduction**

Computer simulation modeling of large trucks and trailers traversing grade crossings was conducted as part of this research study. However, before conducting the simulations, baseline testing was performed to evaluate suspension properties, dynamic trailer and truck movements, and vehicle accelerations when traversing a sample rail grade crossing geometry. Five drive-over speed table tests were performed on September 21, 2017 at the MwRSF Outdoor Test Site. Test nos. UTCRS-1 through UTCRS-4 were analyzed and are discussed in this chapter. Test no. UTCRS-5 was not analyzed due to technical difficulties during the test.

### **3.2 Test Facility**

The Outdoor Test Site is located at the Lincoln Air Park on the northwest side of the Lincoln Municipal Airport and is approximately 5 miles (8.0 km) northwest of the University of Nebraska-Lincoln (UNL).

### **3.3 Speed Table**

Ideally, instrumenting and evaluating trucks crossing real grade crossings is desirable. However, due to the difficulty and risk associated with traversing real grade crossings, researchers utilized a previously-constructed, tall speed table shape as a replica grade crossing geometry. A speed table resembles a railroad crossing, but with steeper and shorter approach slopes. The speed table used in test nos. UTCRS-1 through UTCRS-4 is shown in Figure 39 and the profile drawing is shown in Figure 40. The speed table was 30 ft (9.1 m) long and 8 in. (203 mm) tall at the highest point, with 10-ft (3.0-m) long approach and departure slopes with grades of 6.67 percent on each side.





Figure 39. Speed Table for Test Nos. UTCRS-1 through UTCRS-4

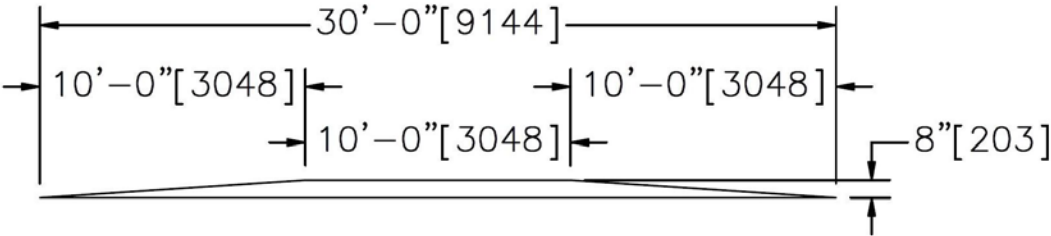

Figure 40. Speed Table Dimensions ft-in. (mm)

**3.4 Test Vehicle**

The Crete Carrier Corporation, located in Lincoln, Nebraska, supplied a 2018 International semi-truck, a 2013 Wabash van trailer, and a professional driver for a day to perform test nos. UTCRS-1 through UTCRS-4. The tractor-trailer is shown in Figure 41, and vehicle dimensions are shown in Figure 42. Measurements which were not recorded are denoted with “n/a,” as shown in Figure 42.

Portable truck scales were utilized to weigh the tractor-trailer. Each wheel or dual wheels, on both the truck and trailer, were weighed, as shown in Figure 43. The total weight of the vehicle was 70,650 lb (32,046 kg) and each axle weight is shown in Figure 42.

In addition to measuring and weighing the tractor-trailer, 3D scans of the test vehicle were taken using a Faro Focus X130 to produce highly-accurate vehicle geometries for post-test references. The scans were analyzed and registered using the Scene program and the results are shown in Figure 44. Square, black- and white-checkered targets were placed on the vehicle for



reference to be viewed from the high-speed digital video cameras and aid in the video analysis, as shown in Figure 45.



Figure 41. Crete Carrier Tractor-Trailer

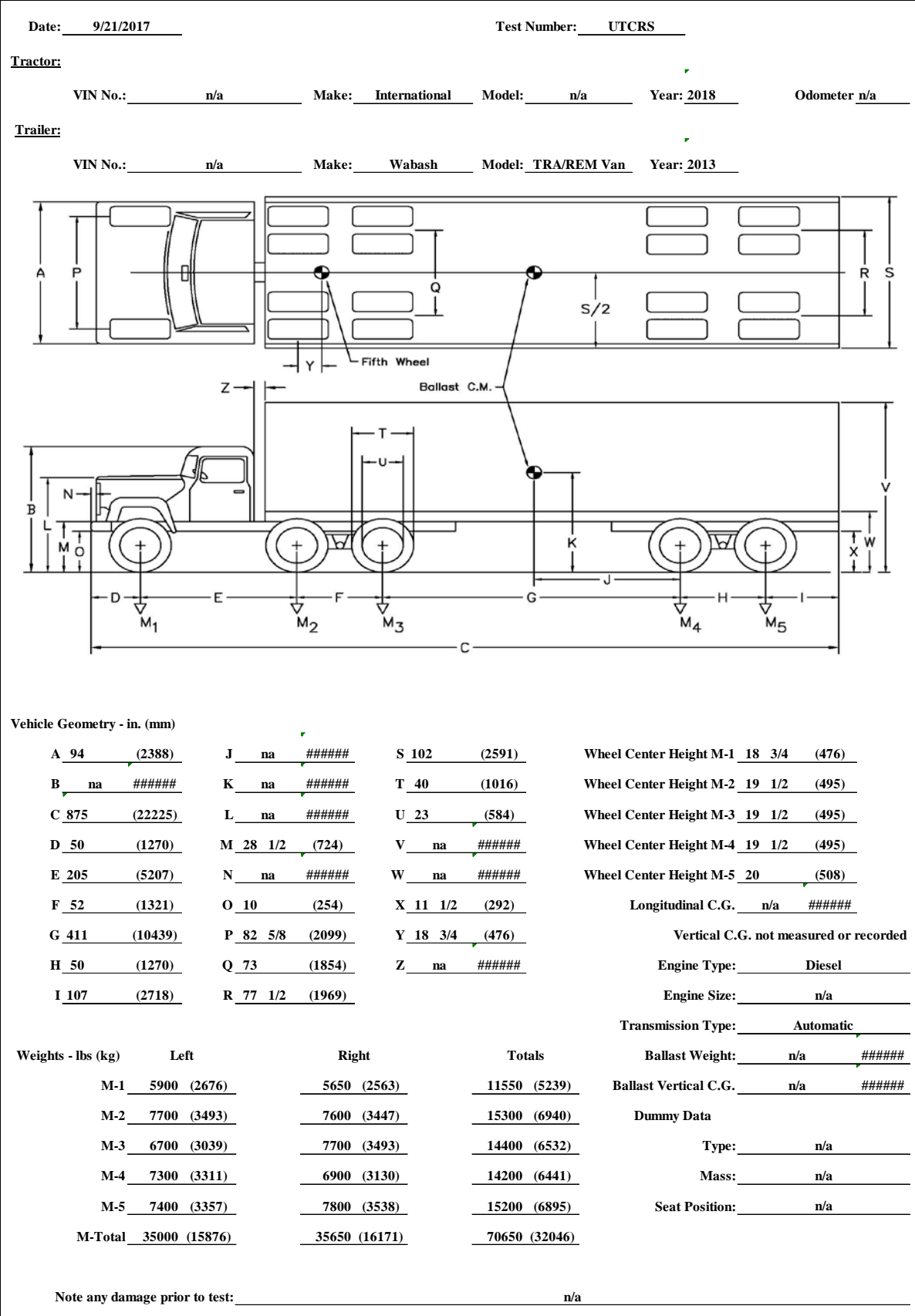

Figure 42. Vehicle Dimensions, Test Nos. UTCRS-1 through UTCRS-4





Figure 43. Portable Heavy Duty Truck Scales Weighing the Crete Carrier Tractor-Trailer



Figure 44. 3D Scan of the Crete Carrier Tractor-Trailer



Figure 45. Crete Carrier Tractor-Trailer with Target Stickers

The tractor was equipped with air ride suspension, as shown in Figure 46. The trailer was equipped with leaf spring suspension. Measurements were taken of the right rear leaf spring, shown in Figure 47. The distance from eyelet to eyelet was  $43\frac{3}{4}$  in. (1.1 m), distance E in Figure 48. The vertical distance between the eyelet and the bottom of the spring was 6 in. (152 mm). The thickness of each leaf was  $\frac{3}{4}$  in. (19 mm), totaling  $2\frac{1}{4}$  in. (57 mm), noted as distance D in Figure 48.

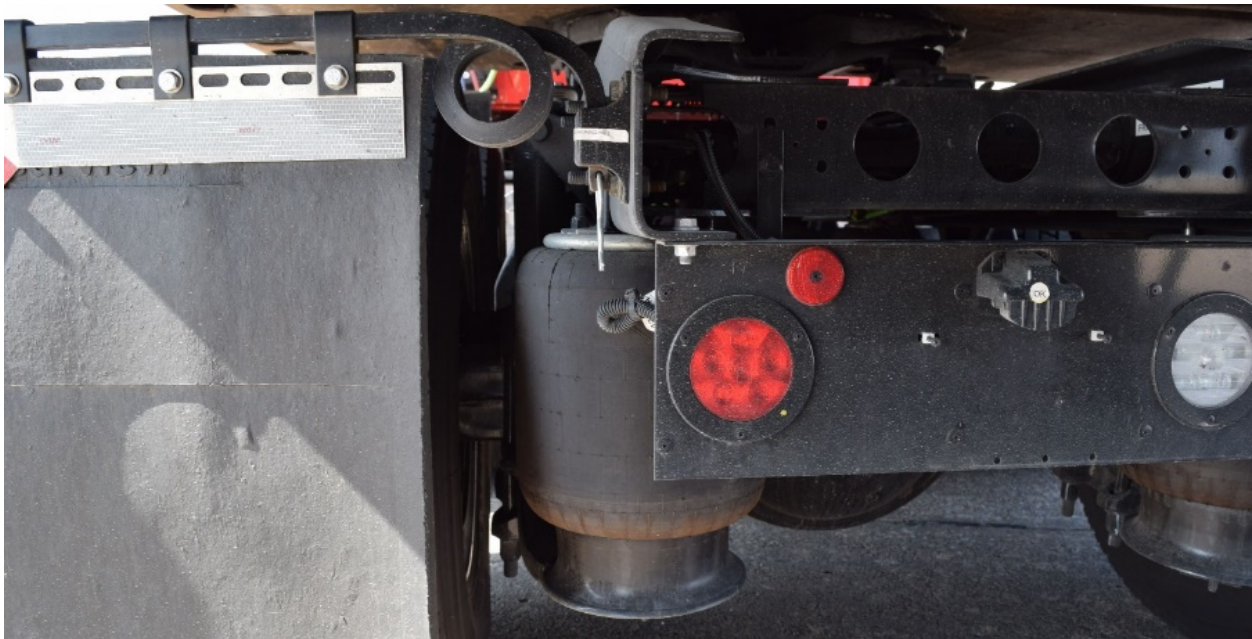

Figure 46. Air Ride Suspension on the Crete Carrier Tractor





Figure 47. Leaf Springs on the Right Rear Wheel of the Crete Carrier Trailer

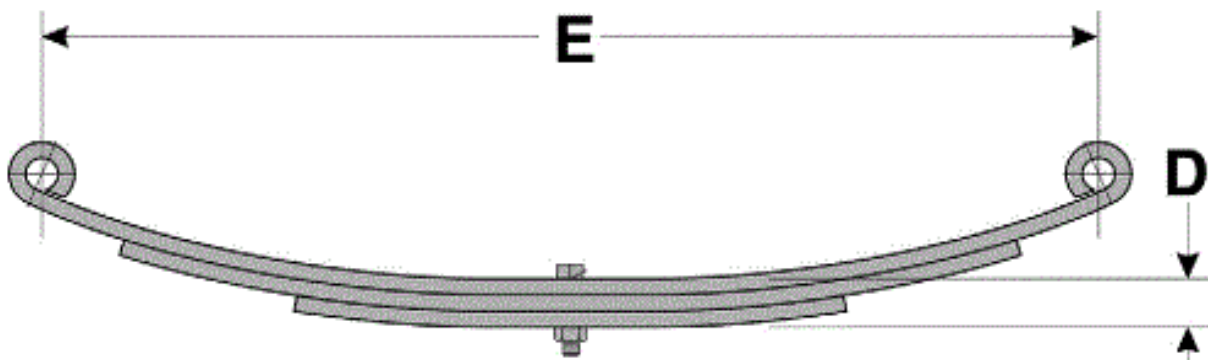

Figure 48. Leaf Spring Diagram

### 3.5 Data Acquisition System

#### 3.5.1 Accelerometer

A VC4000 accelerometer was attached to the trailer, as shown in Figure 49. The accelerometer collected various data: acceleration in the x, y, and z directions, compass degrees, GPS speed, GPS distance, GPS latitude and longitude in degrees, pitch rate, and yaw rate. The collected acceleration data was filtered using a CFC-180 filter. A customized Microsoft Excel worksheet was used to analyze and plot the accelerometer data. Plots of longitudinal, lateral, and vertical change in displacement, change in velocity, and acceleration are shown in Appendix C.



Figure 49. VC4000 Accelerometer Mounted on Trailer

**3.5.2 Digital Photography**

Six GoPro digital video cameras were utilized to film tests nos. UTCRS-1 through UTCRS-4. Camera details, camera operating speeds, and a schematic of the camera locations relative to the system are shown in Figure 50. The high-speed videos were analyzed using TEMA Motion and RedLake MotionScope software programs. A Nikon digital still camera was used to document test conditions.

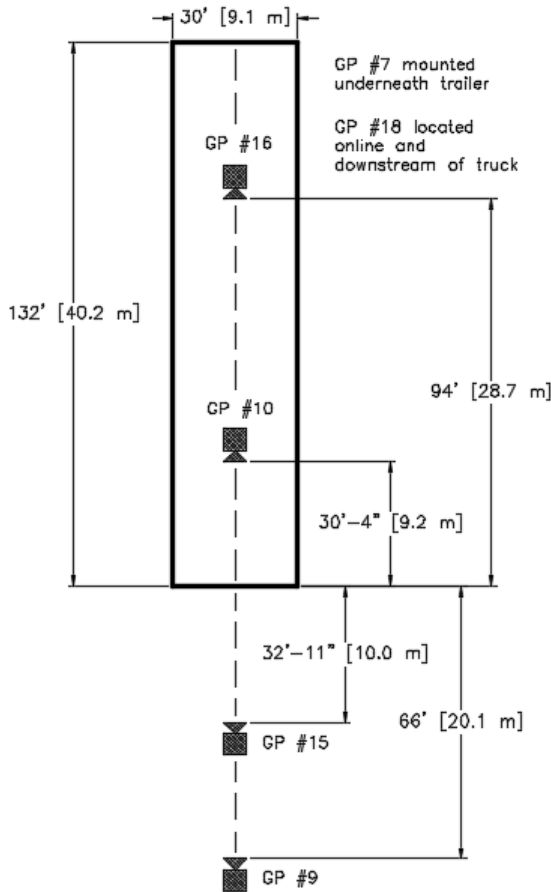

No.	Type	Operating Speed (frames/sec)
GP-7	GoPro Hero 4	240
GP-9	GoPro Hero 4	120
GP-10	GoPro Hero 4	240
GP-15	GoPro Hero 4	240
GP-16	GoPro Hero 4	120
GP-18	GoPro Hero 4	120

Figure 50. Camera Locations, Types, and Speeds, Test Nos. UTCRS-1 through UTCRS-4

### 3.6 Weather Conditions

Test nos. UTCRS-1 through UTCRS-4 were conducted on September 21, 2017 at approximately 1:30 p.m. The weather conditions as per the National Oceanic and Atmospheric Administration (station 14939/LNK) were reported and are shown in Table 4.

Table 4. Weather Conditions, Test Nos. UTCRS-1 through UTCRS-4

Temperature	93° F
Humidity	47 %
Wind Speed	25 mph
Wind Direction	160° from True North
Sky Conditions	Sunny
Visibility	10 Statute Miles
Pavement Surface	Dry
Previous 3-Day Precipitation	0.27 in.
Previous 7-Day Precipitation	0.45 in.

### 3.7 Beginning and End of Test Determination

The beginning of each test, or time 0 for each test, was when the tractor front tires contacted the speed table, shown in Figure 51. Each test ended when the trailer rear tires contacted the ground, or when the trailer rear tires lost contact with the speed table, shown in Figure 52.



Figure 51. Beginning of Test for Test Nos. UTCRS-1 through UTCRS-4





Figure 52. End of Test for Test Nos. UTCRS-1 through UTCRS-4

### 3.8 Test Procedure

The test plan is outlined in Figures 53 through Figure 54. Test nos. UTCRS-1 and UTCRS-2 had a targeted speed of 5 mph (8.0 km/h). Test nos. UTCRS-3 and UTCRS-4 had a targeted speed of 10 mph (16.1 km/h).

Targets were placed on the tractor-trailer to measure vertical displacements of the vehicle with video analysis software. The target locations and names are shown in Figures 55 and 56, respectively. Dimensions which were not collected were denoted with “n/a,” as shown in Figure 55.

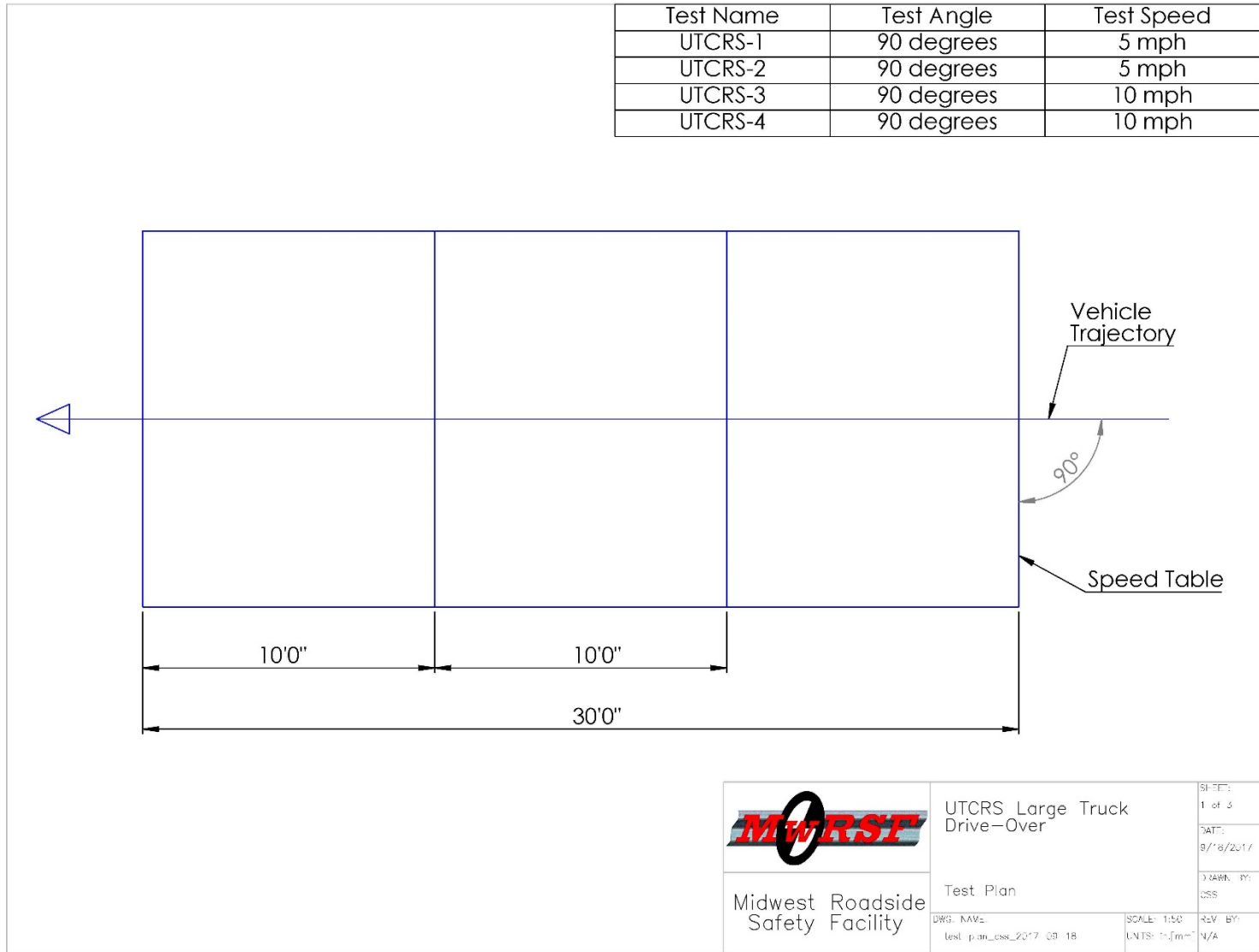

Figure 53. UTCRS Large Truck Drive-Over Test Plan – Page 1

Test Procedure for UTCRS Drive-Over Tests

NOTE: External photography (e.g., digital video cameras) may be arranged prior to the arrival of the Crete driver.

- 1) Acquire axle weights. The weight measurements may be incremental at MwRSF test site or performed by external resource (e.g., Nebraska State Patrol).
- 2) Measure external vehicle dimensions in accordance with MwRSF standard vehicle documentation procedures.
- 3) Apply adhesive targets to the side of the tractor and trailer in known locations. If possible, situate and apply stickers loosely for easier removal after testing is completed. Potential means of reduced adhesion include leaving a portion of the peel-off paper attached to the sticker for a pull-off removal "tab". Measure and record spacing of targets.
- 4) Install the VC4000 on the truck or trailer. It is preferred that the VC4000 be installed on the side of the truck above the wheels and on which the adhesive target stickers are applied. Alternative acceptable locations include (in order of preference): rear of trailer on door; above wheels on side of vehicle opposite to camera photography; in cab.
- 5) Install digital video camera(s), if any, on the suspension and in cab. Location, placement, and number of onboard cameras is at discretion of Test Site Manager.
- 6) Document the vehicle with photographs after the adhesive targets, VC4000, and onboard digital video cameras (if any) are installed. If time permits, it is desired that at least four point cloud scans are obtained using the FARO Focus X130 of the vehicle and instrumentation setup, at the back corner, side, and front corner of the vehicle with targets shown, as well as beneath the trailer to document the suspension properties. Scan quality may be limited and scan direction minimized to reduce time and file size; all dimensions are for documentation purposes only.
- 7) Conduct test nos. UTCRS-1 through UTCRS-4.

 Midwest Roadside Safety Facility	UTCRS Large Truck Drive-Over	SHEET: 2 of 3
	Description of View	DATE: 8/18/2017
DWG NAME: test_plan_css_2017_08_18	SCALE: 1:50 UNITS: 1:1m	DRAWN BY: CSS
		REV BY: N/A

Figure 54. UTCRS Large Truck Drive-Over Test Plan – Page 2

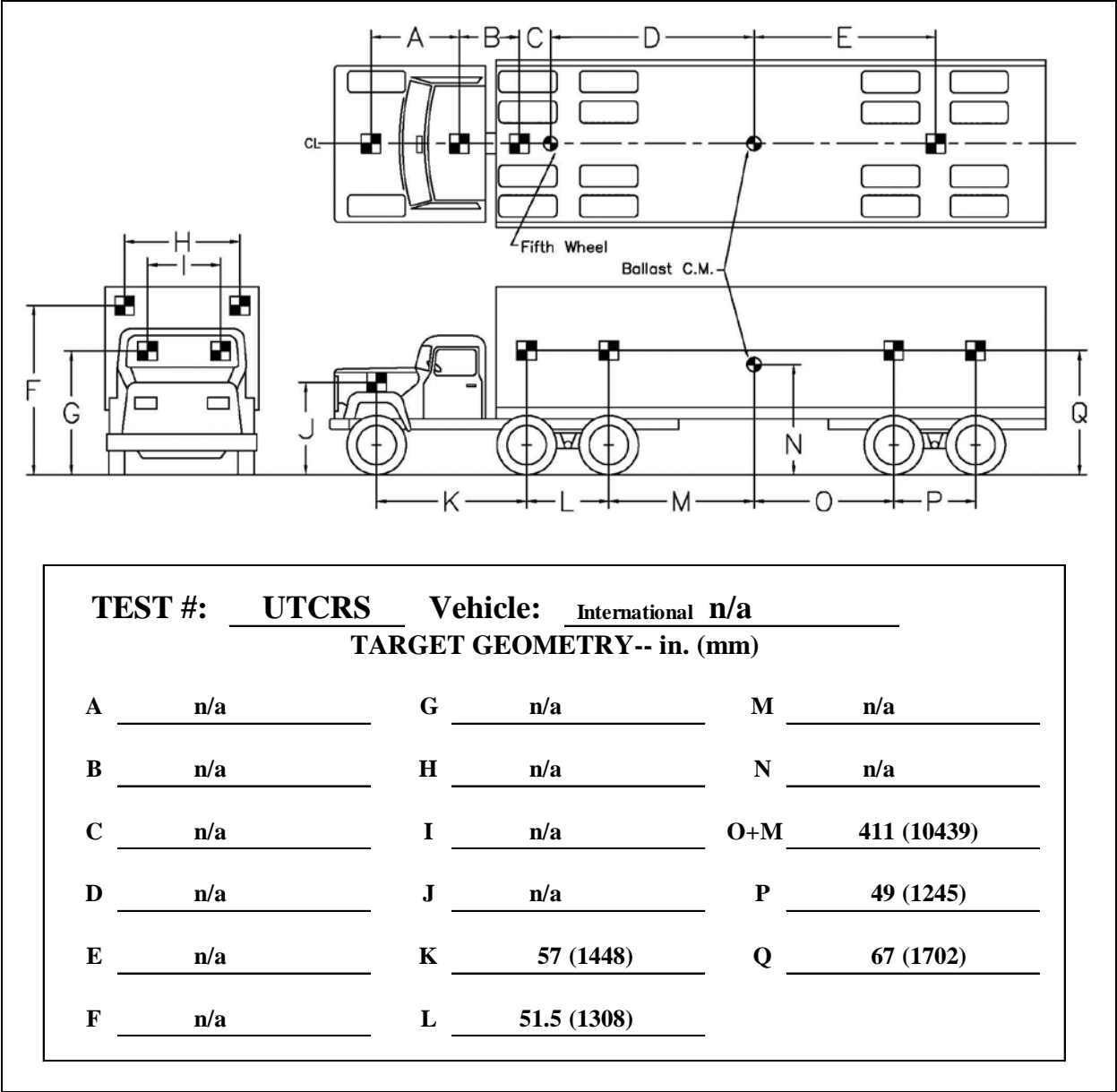

Figure 55. Target Locations for Test Nos. UTCRS-1 through UTCRS-4



Figure 56. Target Names for Test Nos. UTCRS-1 through UTCRS-4

### 3.9 Data Processing

A total of six videos were recorded for each test. Only two cameras were placed on the side of the trailer which had the targets, the view shown in Figure 57 and one wider view. The camera capturing the wider view was not perpendicular to the truck and was far enough away from the truck that video analysis was not able to accurately track all the targets throughout the entire test. Therefore, the view shown in Figure 57 was used to determine vertical displacement of the trailer.

The vertical displacement from video analysis was calculated by subtracting the original target height at the beginning of the video from the height at subsequent times. Because the video view is only as wide as the speed table, the first trailer target height is slightly elevated, as the vehicle has already begun its ascent of the speed table, as shown in Figure 57. Due to the narrow view, the calculated vertical displacement of the trailer targets may be slightly lower than the actual vertical displacement.



Figure 57. Video Analysis with Target First Position Slightly Elevated

### 3.10 Test No. UTCRS-1

The tractor-trailer traversed the speed table at an average speed of 8.5 mph (13.7 km/h). A sequential description of the impact events is contained in Table 5 and sequential photographs are shown in Figure 58.

Data collected during test no. UTCRS-1 with the VC4000 accelerometer was analyzed and the resulting graphs are shown in Appendix C, Figures C-1 through C-9. These graphs include longitudinal, lateral, and vertical acceleration, change in velocity, and change in displacement.

GPS longitude and latitude data was collected with the VC4000 and input into Google Earth. The position points were overlaid on a map of the test site to illustrate the vehicle trajectory, shown in Figure 59, in addition to an outline of the speed table's approximate location.

The vertical displacement of targets Trailer 3 and Trailer 4 were tracked with video analysis software and graphed. These two targets were placed on either side of the accelerometer, and the resulting displacements were compared with the accelerometer's vertical displacement, as shown in Figure 60. The displacement magnitude for the targets and accelerometer were very similar. The maximum vertical displacements from video analysis and the accelerometer were 7.26 in. (184 mm) and 7.03 in. (179 mm), respectively. The test lasted for approximately 7.25 seconds.

Table 5. Sequential Description of Events, Test No. UTCRS-1

TIME (sec)	EVENT
0.000	Tractor's front tires contacted the speed table.
4.408	Trailer's front tires contacted the speed table.
6.583	Trailer's front tires contacted the ground.
6.958	Trailer's rear tires lost contact with the speed table.





0.000 sec



2.617 sec



4.408 sec



5.667 sec



6.583 sec

Figure 58. Sequential Photographs, Test No. UTCRS-1



Figure 59. GPS Data Overlaid on Google Earth Image of the Test Site, Test No. UTCRS-1

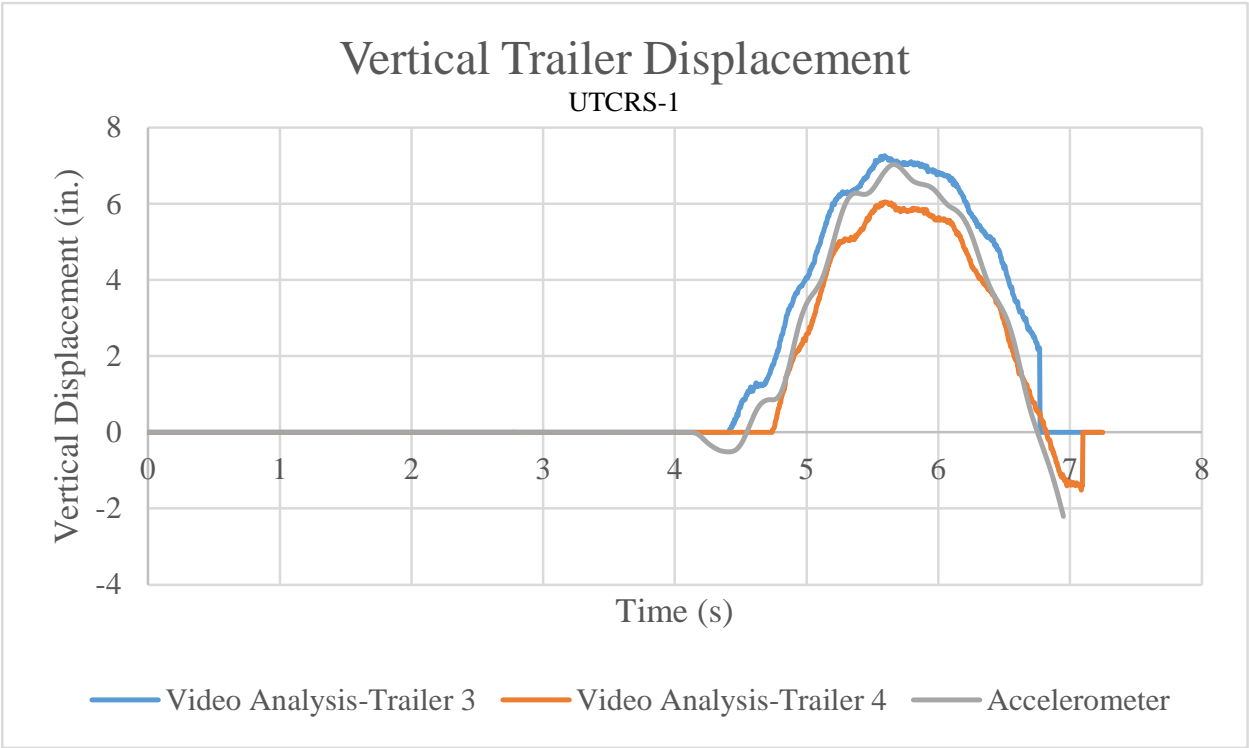

Figure 60. Vertical Displacement, Test No. UTCRS-1



### 3.11 Test No. UTCRS-2

The tractor-trailer traversed the speed table at an average speed of 7.7 mph (12.4 km/h). A sequential description of the impact events is contained in Table 6 and sequential photographs are shown in Figure 61.

Data collected during test no. UTCRS-2 with the VC4000 accelerometer was analyzed and the resulting graphs are shown in Appendix C, Figures C-10 through C-18. These graphs include longitudinal, lateral, and vertical acceleration, change in velocity, and change in displacement.

GPS longitude and latitude data was collected with the VC4000 and input into Google Earth. The position points were overlaid on a map of the test site to illustrate the vehicle trajectory, shown in Figure 62, in addition to an outline of the speed table's approximate location.

The vertical displacement of targets Trailer 3 and Trailer 4 were tracked with video analysis software and graphed. These two targets were placed on either side of the accelerometer, and the resulting displacements were compared with the accelerometer's vertical displacement, shown in Figure 63. The displacement magnitude for the targets and accelerometer were very similar. The maximum vertical displacements from video analysis and the accelerometer were 6.32 in. (161 mm) and 6.31 in. (160 mm), respectively. The test lasted for approximately 8.09 seconds.

Table 6. Sequential Description of Events, Test No. UTCRS-2

TIME (sec)	EVENT
0.000	Tractor's front tires contacted the speed table.
4.708	Trailer's front tires contacted the speed table.
7.542	Trailer's front tires contacted the ground.
7.783	Trailer's rear tires lost contact with the speed table.



0.000 sec



2.850 sec



4.708 sec



6.358 sec



7.542 sec

Figure 61. Sequential Photographs, Test No. UTCRS-2



Figure 62. GPS Data Overlaid on Google Earth Image of the Test Site, Test No. UTCRS-2

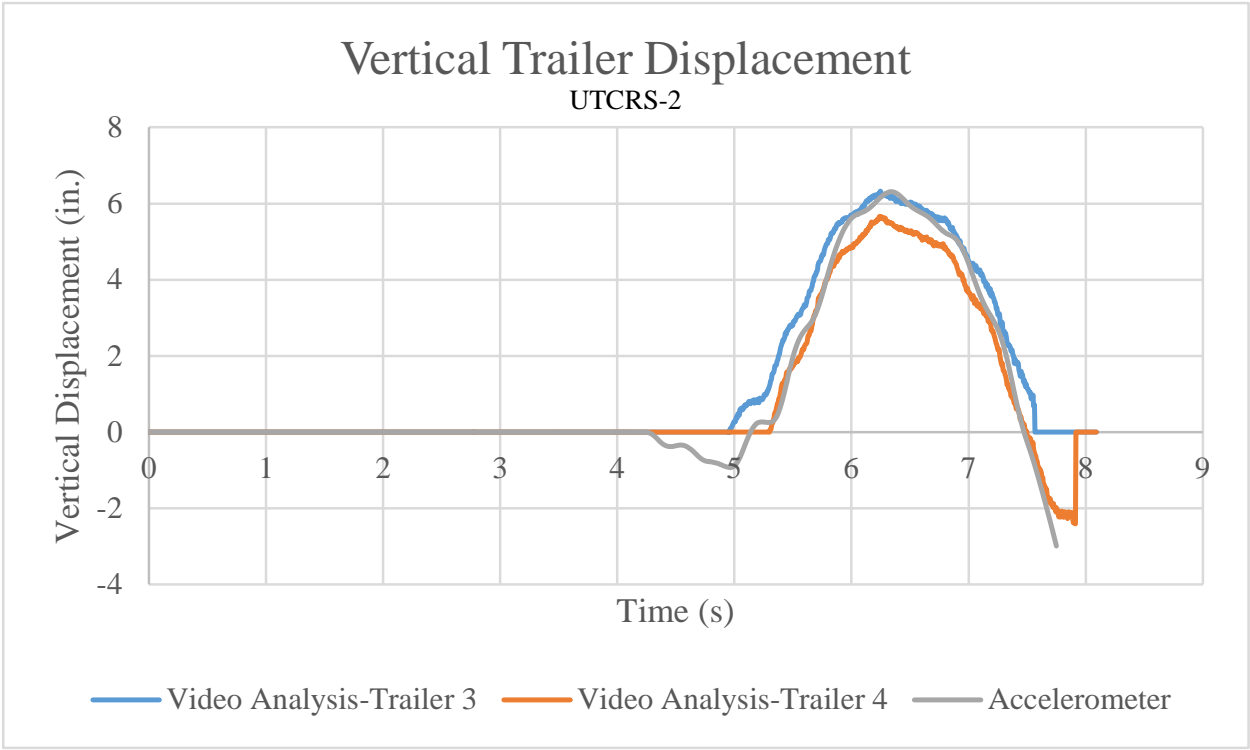

Figure 63. Vertical Displacement, Test No. UTCRS-2

### 3.12 Test No. UTCRS-3

The tractor-trailer traversed the speed table at an average speed of 11.7 mph (18.8 km/h). A sequential description of the impact events is contained in Table 7 and sequential photographs are shown in Figure 64.

Data collected during test no. UTCRS-3 with the VC4000 accelerometer was analyzed and the resulting graphs are shown in Appendix C, Figures C-19 through C-27. These graphs include longitudinal, lateral, and vertical acceleration, change in velocity, and change in displacement.

GPS longitude and latitude data was collected with the VC4000 and input into Google Earth. The position points were overlaid on a map of the test site to illustrate the vehicle trajectory, shown in Figure 65, in addition to an outline of the speed table’s approximate location.

The vertical displacement of targets Trailer 3 and Trailer 4 were tracked with video analysis software and graphed. These two targets were placed on either side of the accelerometer, and the resulting displacements were compared with the accelerometer’s vertical displacement, shown in Figure 66. The displacement magnitude for the targets and accelerometer were very similar. The maximum vertical displacements from video analysis and the accelerometer were 7.09 in. (180 mm) and 8.22 in. (209 mm), respectively. The test lasted for approximately 5.40 seconds.

Table 7. Sequential Description of Events, Test No. UTCRS-3

TIME (sec)	EVENT
0.000	Tractor’s front tires contacted the speed table.
3.150	Trailer’s front tires contacted the speed table.
4.850	Trailer’s front tires contacted the ground.
5.075	Trailer’s rear tires lost contact with the speed table.



0.000 sec



1.850 sec



3.150 sec



4.108 sec



4.850 sec

Figure 64. Sequential Photographs, Test No. UTCRS-3





Figure 65. GPS Data Overlaid on Google Earth Image of the Test Site, Test No. UTCRS-3

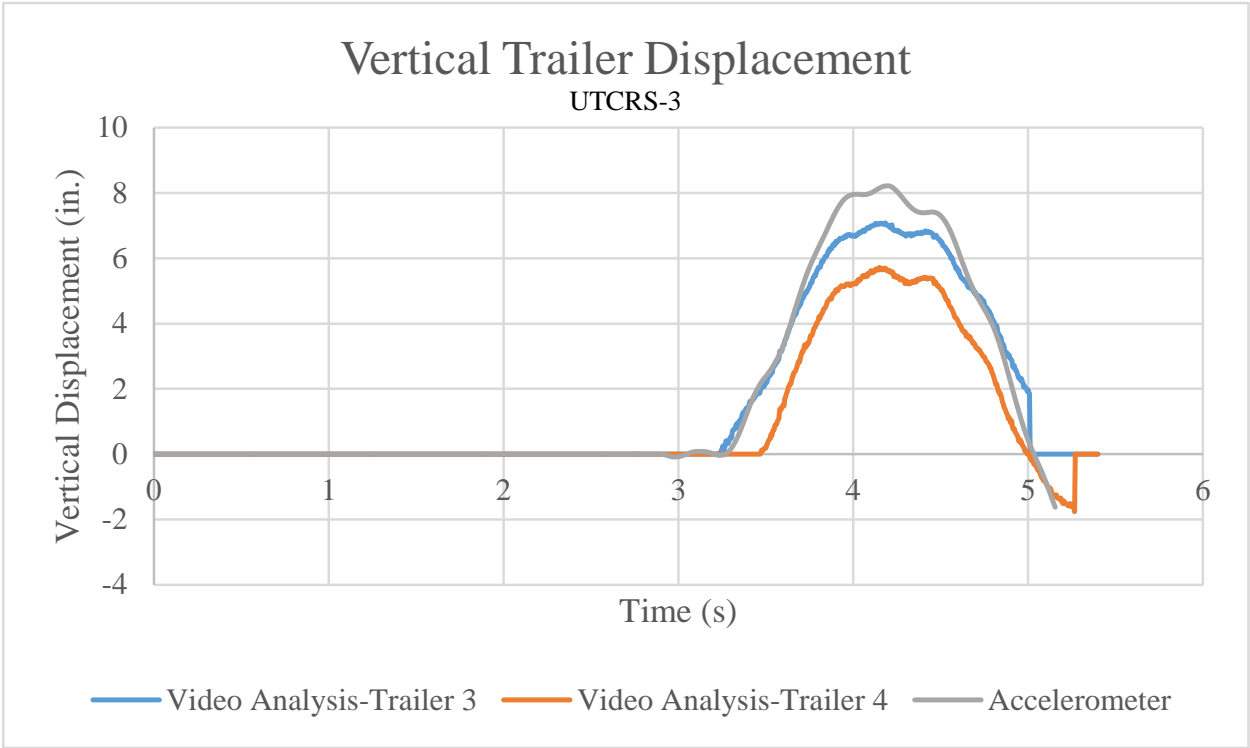

Figure 66. Vertical Displacement, Test No. UTCRS-3

### 3.13 Test No. UTCRS-4

The tractor-trailer traversed the speed table at an average speed of 12.8 mph (20.5 km/h). A sequential description of the impact events is contained in Table 8 and sequential photographs are shown in Figure 67.

Data collected during test no. UTCRS-4 with the VC4000 accelerometer was analyzed and the resulting graphs are shown in Appendix C, Figures C-28 through C-36. These graphs include longitudinal, lateral, and vertical acceleration, change in velocity, and change in displacement.

GPS longitude and latitude data was collected with the VC4000 and input into Google Earth. The position points were overlaid on a map of the test site to illustrate the vehicle trajectory, shown in Figure 68, in addition to an outline of the speed table's approximate location.

The vertical displacement of targets Trailer 3 and Trailer 4 were tracked with video analysis software and graphed. These two targets were placed on either side of the accelerometer, and the resulting displacements were compared with the accelerometer's vertical displacement, shown in Figure 69. The displacement magnitude for the targets and accelerometer were very similar. The maximum vertical displacements from video analysis and the accelerometer were 6.96 in. (177 mm) and 8.83 in. (224 mm), respectively. The test lasted for approximately 4.92 seconds.

Table 8. Sequential Description of Events, Test No. UTCRS-4

TIME (sec)	EVENT
0.000	Tractor's front tires contacted the speed table.
2.942	Trailer's front tires contacted the speed table.
4.433	Trailer's front tires contacted the ground.
4.717	Trailer's rear tires lost contact with the speed table.



0.000 sec



1.758 sec



2.942 sec



3.808 sec



4.433 sec

Figure 67. Sequential Photographs, Test No. UTCRS-4





Figure 68. GPS Data Overlaid on Google Earth Image of the Test Site, Test No. UTCRS-4

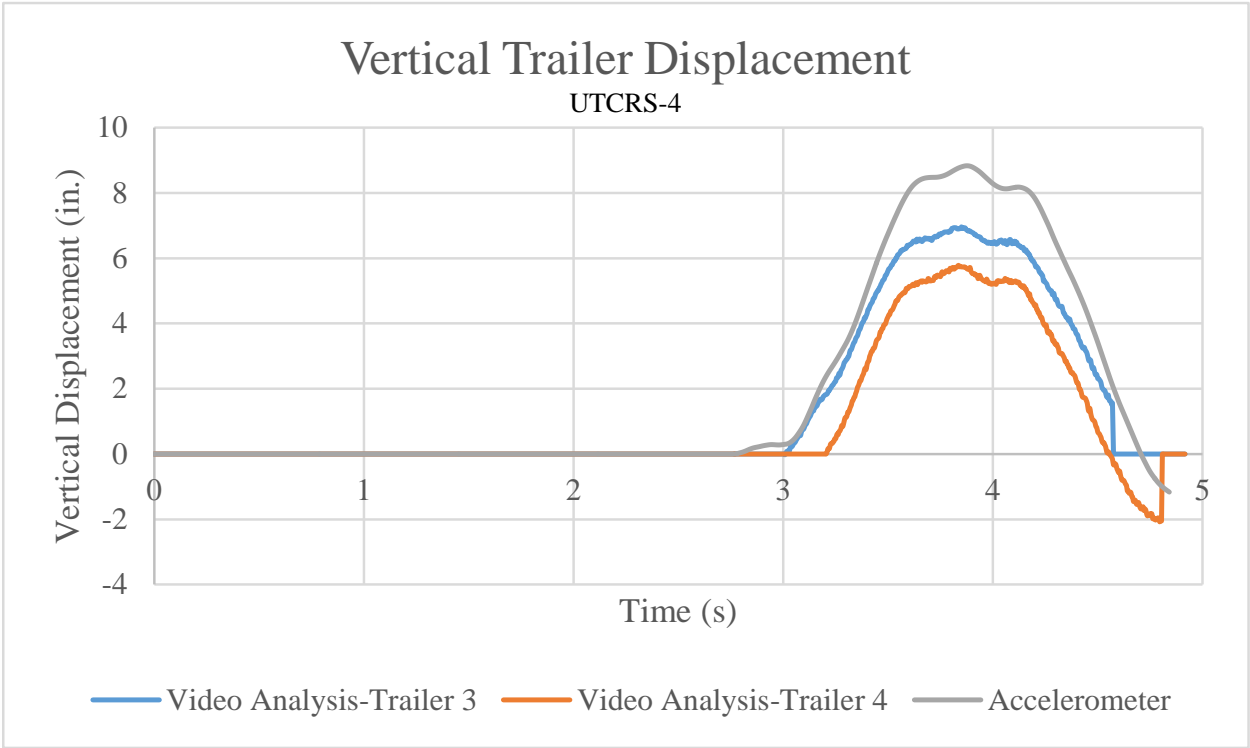

Figure 69. Vertical Displacement, Test No. UTCRS-4

### 3.14 Results and Discussions

The purpose of the four speed table tests was to evaluate trailer dynamic movement and determine the sprung mass vertical displacement as the tractor-trailer traversed the speed table. The displacements obtained from video analysis and the accelerometer had average variations of 3.3% for test no. UTCRS-1, 0.2% for test no. UTCRS-2, 15.9% for test no. UTCRS-3, and 26.9% for test no. UTCRS-4.

Vertical displacements for test nos. UTCRS-1 through UTCRS-4 ranged between 6.31 in. (160 mm) and 8.83 in. (224 mm) for speeds between 7 and 13 mph (11.3 and 20.9 km/h). The speed table was 8 in. (203 mm) tall, therefore the maximum suspension movement was compressing 1.69 in. (43 mm) or extending 0.83 in. (21 mm). Researchers reviewed the results and determined that the offset video and small rotational displacements of the VC4000 at the attachments may have contributed to the overall error between the expected 8-in. vertical displacement of the accelerometer and the actual, recorded value, which was typically less than 8 in. However, it was also noted that the configuration of the fifth wheel connection may have applied a torque loading on the leaf spring, which combined with the trailer weight distribution, could have increased the loading on the trailer and the associated leaf spring suspension when traversing the speed table, resulting in less than expected vertical displacement at the VC4000 location and video analysis target height. In addition, the air ride suspension at the truck rear wheels could have also compressed and not yet rebounded during and after traversing the speed table, resulting in an overall reduced load height at the rear wheels. Researchers recommend further study to determine if wheel and suspension compression is a recurring phenomenon when traversing rail grade crossings.

### **3.15 Overall Results and Conclusions**

Suspension compression or extension could affect a vehicle's ability to safely traverse a highway-rail grade crossing, especially vehicles with low ground clearances. To accurately model vehicles traversing highway-rail grade crossings, TruckSim simulations of the four speed table tests were performed and the vertical displacements of the trailer were graphed. This information is discussed in Section 8.1.

## **4 FIELD SURVEY OF HIGHWAY-RAIL CROSSINGS IN NEBRASKA**

### **4.1 Introduction**

The state of Nebraska has 4,979 at-grade railroad crossings [43]. The FRA database and the Google Street View feature were utilized to identify highway-rail grade crossings across the state which appeared to have steep approach grades or scrape marks on the crossing surface. Seven crossings with scrape marks were identified for analysis. One additional crossing was recommended by the Nebraska Department of Transportation (NDOT). Three of the seven selected crossings were evaluated by conducting on-site 3D geo-mapping with permission of the railway. The collected crossing geometries were modeled in TruckSim and low, long-wheelbase vehicles were simulated traversing the crossings. The simulation results are discussed in Chapter 8.

### **4.2 FRA Inventory Forms**

The FRA maintains inventory forms on every crossing in the U.S. These forms include the crossing longitude and latitude location, train count, low ground clearance sign presence, highway-rail intersection angle, average daily traffic with an estimate of the percentage of trucks, and other information. The forms do not include crossing grade information. The most recent inventory form for each crossing is available on the FRA Office of Safety Analysis website [44] and the template is shown in Figures 70 and 71. Inventory forms for the seven crossings are provided in Appendix A.

### **4.3 FRA Accident Reports**

The FRA publishes accident reports for every train-vehicle crash. These reports include the United States Department of Transportation (USDOT) crossing identification number, type of vehicle involved, position of the vehicle (i.e., stalled or stuck on crossing, stopped on crossing, moving over crossing, trapped on crossing by traffic, or blocked on crossing by gates), a narrative description of the crash, and other information. The narrative description is not filled out on every

report and the reports do not contain crossing grade information. Accident reports from 1975 through April 2017 were available on the FRA Office of Safety Analysis website [44] at the time this research was conducted. The accident report template is shown in Figures 72 and 73, and accident reports for three of the seven crossings are provided in Appendix B. The other four crossings did not have accident reports.

**U.S. DOT CROSSING INVENTORY FORM**

DEPARTMENT OF TRANSPORTATION  
FEDERAL RAILROAD ADMINISTRATION (FRA)

**OMB No. 2130-0017**

A. Initiating Agency <input type="checkbox"/> Railroad <input type="checkbox"/> State		B. Crossing Number (max. 7 char.)		C. Reason for Update <input type="checkbox"/> Changes in Existing Data <input type="checkbox"/> New Crossing <input type="checkbox"/> Closed Crossing or Abandoned		D. Effective Date (MM/DD/YYYY)	
<b>Part I: Location and Classification Information</b>							
1. Railroad Oper. Co. (code (max. 4 char.) or name)				2. State (2 char.)		3. County (max 20 char.)	
4. Railroad Division or Region (max. 14 char.)		5. Railroad Subdivision or District (max. 14 char.)		6. Branch or Line Name (max. 15 char.)		7. RR Milepost (max. 7 char.) (nnnnn nn)	
8. RR I.D. No. (max. 10 char.)		9. Nearest RR Timetable Station (max. 15 char.) (optional)		10. Parent RR (max. 4 char.) (if applicable)		11. Crossing Owner (RR or Company name) (if applicable)	
12. City (max. 16 char.) (check one) <input type="checkbox"/> In <input type="checkbox"/> Near				13. Street or Road Name (max. 17 char.)		<b>STATE SUPPLIED INFORMATION</b>	
14. Highway Type & No. (max. 7 char.)		15. ENS Sign Installed (1-800) <input type="checkbox"/> Yes <input type="checkbox"/> No		16. Quiet Zone <input type="checkbox"/> No <input type="checkbox"/> 24 hr <input type="checkbox"/> Partial <input type="checkbox"/> Unknown		21. HSR Corridor ID (2 char.)	
17. Crossing Type (choose one only) <input type="checkbox"/> Public <input type="checkbox"/> Private <input type="checkbox"/> Pedestrian		18. Crossing Position <input type="checkbox"/> At Grade <input type="checkbox"/> RR Under <input type="checkbox"/> RR Over		19. Type of Passenger Service <input type="checkbox"/> AMTRAK <input type="checkbox"/> AMTRAK & Other <input type="checkbox"/> Other <input type="checkbox"/> None		20. Average Passenger Train Count Per Day _____	
						22. County Map Ref. No. (max. 10 char.)	
						23. Latitude (max. 10 char., nn.nnnnnn)	
						24. Longitude (max. 11 char., nnn.nnnnnn)	
						25. Lat/Long Source <input type="checkbox"/> Actual <input type="checkbox"/> Estimated	
26. Is There an Adjacent Crossing With a Separate Number? <input type="checkbox"/> Yes <input type="checkbox"/> No If Yes, Provide Number _____ (7 characters)							
<b>27. PRIVATE CROSSING INFORMATION</b>							
27.A. Category (check one) <input type="checkbox"/> Farm <input type="checkbox"/> Residential <input type="checkbox"/> Recreational <input type="checkbox"/> Industrial <input type="checkbox"/> Commercial		27.B. Public Access <input type="checkbox"/> Yes <input type="checkbox"/> No <input type="checkbox"/> Unknown		27.C. Signs/Signals <input type="checkbox"/> None <input type="checkbox"/> Signs Specify (max. 15 char.) _____ <input type="checkbox"/> Signals Specify (max. 15 char.) _____			
28.A. Railroad Use (max. 20 char.)				29.A. State Use (max. 20 char.)			
28.B. Railroad Use (max. 20 char.)				29.B. State Use (max. 20 char.)			
28.C. Railroad Use (max. 20 char.)				29.C. State Use (max. 20 char.)			
28.D. Railroad Use (max. 20 char.)				29.D. State Use (max. 20 char.)			
30. Narrative (max. 100 char.)							
31. Emergency Contact (Telephone No.)			32. Railroad Contact (Telephone No.)			33. State Contact (Telephone No.)	
<b>MUST COMPLETE REMAINDER OF FORM FOR PUBLIC VEHICLE CROSSINGS AT GRADE</b>							
<b>Part II: Railroad Information</b>							
1. Number of Daily Train Movements							
1.A. Total Trains _____		1.B. Total Switching Trains _____		1.C. Total Daylight Thru Trains (6 AM to 6 PM) _____		1.D. Check if Less Than One Movement Per Day <input type="checkbox"/>	
2. Speed of Train at Crossing		2.A. Maximum Time Table Speed (mph) _____		2.B. Typical Speed Range Over Crossing (mph) from _____ to _____			
3. Type and Number of Tracks Main _____ Other _____ If Other, Specify (max. 10 char.) _____							
4. Does Another RR Operate a Separate Track at Crossing? <input type="checkbox"/> Yes If Yes, Specify RR (max. 16 char.) _____ <input type="checkbox"/> No				5. Does Another RR Operate Over Your Track at Crossing? <input type="checkbox"/> Yes If Yes, Specify RR (max. 16 char.) _____ <input type="checkbox"/> No			

**U.S. DOT CROSSING INVENTORY FORM**

B. Crossing Number (max. 7 char.)	PAGE 2	D. Effective Date (MM/DD/YYYY)
<b>Part III: Traffic Control Device Information</b>		
1. No Signs or Signals <input type="checkbox"/> Check if Correct	2. Type of Warning Device at Crossing – Signs (specify number of each)	
2.A. Crossbucks _____	2.B. Highway Stop Signs (R1-1) _____	2.C. RR Advance Warning Signs (W10-1) <input type="checkbox"/> Yes <input type="checkbox"/> No
2.D. Hump Crossing Sign (W10-5) <input type="checkbox"/> Yes <input type="checkbox"/> No <input type="checkbox"/> Unknown		
2.E. Pavement Markings <input type="checkbox"/> Stoplines <input type="checkbox"/> RR Xing Symbols <input type="checkbox"/> None		2.F. Other Signs (specify MUTCD type) Number _____ Specify Type (max. 10 char.) _____ Number _____ Specify Type (max. 10 char.) _____
3. Type of Warning Device at Crossing – Train Activated Devices (specify number of each)		
3.A. Gates _____	3.B. Four-quadrant (or full barrier) Gates <input type="checkbox"/> Yes <input type="checkbox"/> No	3.C. Cantilevered (or Bridged) Flashing Lights Over Traffic Lane (number) _____ Not Over Traffic Lane (number) _____
3.D. Mast Mounted Flashing Lights (number) _____		3.E. Number of Flashing Light Pairs _____
3.F. Other Flashing Lights Number _____ Specify Type (max. 9 char.) _____		3.G. Highway Traffic Signals (number) _____
3.H. Wigwags (number) _____		3.J. Bells (number) _____
3.K. Other Train Activated Warning Devices: (specify) (max. 9 char.) _____		
4. Specify Special Warning Device NOT Train Activated (max. 20 char.) _____		5. Channelization Devices With Gates <input type="checkbox"/> All Approaches <input type="checkbox"/> One Approach <input type="checkbox"/> None
6. Train Detection <input type="checkbox"/> Constant Warning Time <input type="checkbox"/> DC/AFO <input type="checkbox"/> Motion Detectors <input type="checkbox"/> Other <input type="checkbox"/> None	7. Signalling for Train Operation: Is Track Equipped with Train Signals? <input type="checkbox"/> Yes <input type="checkbox"/> No	8. Traffic Light Interconnection/Preemption <input type="checkbox"/> Not Interconnected <input type="checkbox"/> N/A <input type="checkbox"/> Simultaneous Preemption <input type="checkbox"/> Advance Preemption
9. Reserved For Future Use	10. Reserved For Future Use	11. Reserved For Future Use
12. Reserved For Future Use		
<b>Part IV: Physical Characteristics</b>		
1. Type of Development <input type="checkbox"/> Open Space <input type="checkbox"/> Residential <input type="checkbox"/> Commercial <input type="checkbox"/> Industrial <input type="checkbox"/> Institutional		2. Smallest Crossing Angle <input type="checkbox"/> 0° - 29° <input type="checkbox"/> 30° - 59° <input type="checkbox"/> 60° - 90°
3. Number of Traffic Lanes Crossing Railroad _____	4. Are Truck Pullout Lanes Present? <input type="checkbox"/> Yes <input type="checkbox"/> No	5. Is Highway Paved? <input type="checkbox"/> Yes <input type="checkbox"/> No
6. Crossing Surface (on main line)		
<input type="checkbox"/> 1. Timber <input type="checkbox"/> 2. Asphalt	<input type="checkbox"/> 3. Asphalt and Flange <input type="checkbox"/> 4. Concrete	<input type="checkbox"/> 5. Concrete and Rubber
<input type="checkbox"/> 6. Rubber <input type="checkbox"/> 7. Metal	<input type="checkbox"/> 8. Unconsolidated	<input type="checkbox"/> 9. Other (Specify) _____
7. Does Track Run Down a Street? <input type="checkbox"/> Yes <input type="checkbox"/> No	8. Nearby Intersecting Highway? <input type="checkbox"/> Less than 75 feet <input type="checkbox"/> 75 to 200 feet <input type="checkbox"/> 200 to 500 feet <input type="checkbox"/> N/A	
Is it Signalized? <input type="checkbox"/> Yes <input type="checkbox"/> No		
9. Is Crossing Illuminated? (street lights within approx. 50 feet from nearest rail) <input type="checkbox"/> Yes <input type="checkbox"/> No	10. Is Commercial Power Available? <input type="checkbox"/> Yes <input type="checkbox"/> No	11. Space Reserved For Future Use
<b>Part V: Highway Information</b>		
1. Highway System <input type="checkbox"/> Interstate <input type="checkbox"/> Federal Aid, Not NHS <input type="checkbox"/> Nat. Hwy System (NHS) <input type="checkbox"/> Non Federal Aid	2. Is Crossing on State Highway System? <input type="checkbox"/> Yes <input type="checkbox"/> No	3. Functional Classification of Road at Crossing _____
4. Posted Highway Speed _____		
5. Annual Average Daily Traffic (AADT) Year _____ AADT _____	6. Estimate Percent Trucks _____	7. Average Number of School Buses Over Crossing per School Day _____
Public reporting burden for this information collection is estimated to average 15 minutes per response, including the time for reviewing instructions, searching existing data sources, gathering and maintaining the data needed, and completing and reviewing the collection of information. According to the Paperwork Reduction Act of 1995, a federal agency may not conduct or sponsor, and a person is not required to respond to, nor shall a person be subject to a penalty for failure to comply with, a collection of information unless it displays a currently valid OMB control number. The valid OMB control number for this information collection is 2130-0017. All responses to this collection of information are voluntary. Send comments regarding this burden estimate or any other aspect of this collection, including suggestions for reducing this burden to: Information Collection Officer, Federal Railroad Administration, 1120 Vermont Ave., N.W., Washington, D.C. 20590.		

Figure 71. FRA Inventory Form – Page 2 [45]



DEPARTMENT OF TRANSPORTATION  
FEDERAL RAILROAD ADMINISTRATION (FRA)

HIGHWAY-RAIL GRADE CROSSING  
ACCIDENT/INCIDENT REPORT

OMB Approval No.: 2130-0500

1. Name of Reporting Railroad			1a. Alphabetic Code			1b. Railroad Accident/Incident No.							
2. Name of Other Railroad Involved in Train Accident/Incident			2a. Alphabetic Code			2b. Railroad Accident/Incident No.							
3. Name of Railroad Responsible for Track Maintenance (single entry)			3a. Alphabetic Code			3b. Railroad Accident/Incident No.							
4. U. S. DOT Grade Crossing Identification Number			5. Date of Accident/Incident month   day   year			6. Time of Accident/Incident AM <input type="checkbox"/> PM <input type="checkbox"/>							
7. Nearest Railroad Station		8. Division		9. County		10. State Abbr.		Code					
11. City (if in a city)				12. Highway Name or Number Public <input type="checkbox"/> Private <input type="checkbox"/>									
Highway User Involved				Rail Equipment Involved									
13. Type A. Auto D. Pick-up truck B. Truck E. Van C. Truck-trailer F. Bus G. School bus H. Motorcycle J. Other motor vehicle K. Pedestrian M. Other (specify)		Code		17. Equipment 1. Train (units pulling) 2. Train (units pushing) 3. Train (standing)		4. Car(s) (moving) 5. Car(s) (standing) 6. Light loco(s) (moving) 7. Light loco(s) (standing)		8. Other (specify) A. Train pulling- RCL B. Train pushing- RCL C. Train standing- RCL		Code			
14. Vehicle Speed (est. mph at impact)		15. Direction (geographical) 1. North 2. South 3. East 4. West		Code		18. Position of Car Unit in Train							
16. Position 1. Stalled on crossing 2. Stopped on crossing 3. Moving over crossing 4. Trapped		Code		19. Circumstance 1. Rail equipment struck highway user 2. Rail equipment struck by highway user					Code				
20a. Was the highway user and/or rail equipment involved in the impact transporting hazardous materials? 1. Highway user 2. Rail equipment 3. Both 4. Neither				Code		20b. Was there a hazardous materials release by 1. Highway user 2. Rail equipment 3. Both 4. Neither				Code			
20c. State here the name and quantity of the hazardous material released, if any.													
21. Temperature (specify if minus) ° F		22. Visibility (single entry) 1. Dawn 2. Day 3. Dusk 4. Dark		Code		23. Weather (single entry) 1. Clear 2. Cloudy 3. Rain 4. Fog 5. Sleet 6. Snow				Code			
24. Type of Equipment Consist (single entry) 1. Freight train 2. Passenger train 3. Commuter train 4. Work train 5. Single car 6. Cut of cars 7. Yardswitching 8. Light loco(s) 9. Maint./inspect. car A. Spec. MoW Equip.		Code		25. Track Type Used by Rail Equipment Involved 1. Main 2. Yard 3. Siding 4. Industry		Code		26. Track Number or Name					
27. FRA Track Class (1-9, X)		28. Number of Locomotive Units		29. Number of Cars		30. Consist Speed (Recorded speed, if available) R - Recorded E - Estimated MPH		Code		31. Time Table Direction 1. North 2. South 3. East 4. West		Code	
32. Type of Crossing Warning 1. Gates 2. Cantilever FLS 3. Standard FLS 4. Wig wags 5. Hwy traffic signals 6. Audible 7. Crossbucks 8. Stop signs 9. Watchman 10. Flagged by crew 11. Other (specify) 12. None		Code		33. Signaled Crossing Warning (See reverse side for instructions and codes)		Code		34. Whistle Ban 1. Yes 2. No 3. Unknown			Code		
Code(s)		35. Location of Warning 1. Both sides 2. Side of vehicle approach 3. Opposite side of vehicle approach		Code		36. Crossing Warning Interconnected with Highway Signals 1. Yes 2. No 3. Unknown		Code		37. Crossing Illuminated by Street Lights or Special Lights 1. Yes 2. No 3. Unknown			Code
38. Driver's Age		39. Driver's Gender 1. Male 2. Female		Code		40. Driver Drove Behind or in Front of Train and Struck or was Struck by Second Train 1. Yes 2. No 3. Unknown		Code		41. Driver 1. Drove around or thru the gate 2. Stopped and then proceeded 3. Did not stop 4. Stopped on crossing 5. Other (specify)			Code
42. Driver Passed Standing Highway Vehicle 1. Yes 2. No 3. Unknown		Code		43. View of Track Obscured by (primary obstruction) 1. Permanent structure 2. Standing railroad equipment 3. Passing train 4. Topography 5. Vegetation 6. Highway vehicles 7. Other (specify) 8. Not obstructed					Code				
Casualties to:		Killed		Injured		44. Driver was 1. Killed 2. Injured 3. Uninjured		Code		45. Was Driver in the Vehicle? 1. Yes 2. No			Code
46. Highway-Rail Crossing Users						47. Highway Vehicle Property Damage (est. dollar damage)				48. Total Number of Highway-Rail Crossing Users (include driver)			
49. Railroad Employees						50. Total Number of People on Train (include passengers and train crew)				51. Is a Rail Equipment Accident/ Incident Report Being Filed? 1. Yes 2. No			
52. Passengers on Train													
53a. Special Study Block				53b. Special Study Block									
54. Narrative Description (Be specific, and continue on separate sheet if necessary)													
55. Typed Name and Title						56. Signature			57. Date				
NOTE: This report is part of the reporting railroad's accident report pursuant to the accident reports statute and, as such, shall not be admitted as evidence or used for any purpose in any suit or action for damages growing out of any matter mentioned in said report . . . . 49 U.S.C. 20903. See 49 C.F.R. 225.7 (b).													

FORM FRA F 6180.57 (Revised March 2003)

\* NOTE THAT ALL CASUALTIES MUST BE REPORTED ON FORM FRA F 6180.55A

Figure 72. FRA Accident Report – Page 1 [45]

INSTRUCTIONS FOR COMPLETING BLOCK 33
<p>Only if Types 1 - 6, Item 32 are indicated, mark in Block 33 the status of the warning devices at the crossing at the time of the accident, using the following codes:</p> <ol style="list-style-type: none"><li>1. Provided minimum 20-second warning.</li><li>2. Alleged warning time greater than 60 seconds.</li><li>3. Alleged warning time less than 20 seconds.</li><li>4. Alleged no warning.</li><li>5. Confirmed warning time greater than 60 seconds.</li><li>6. Confirmed warning time less than 20 seconds.</li><li>7. Confirmed no warning.</li></ol> <p>If status code 5, 6, or 7 was entered, also enter a letter code explanation from the list below:</p> <ol style="list-style-type: none"><li>A. Insulated rail vehicle.</li><li>B. Storm/lightning damage.</li><li>C. Vandalism.</li><li>D. No power/batteries dead.</li><li>E. Devices down for repair.</li><li>F. Devices out of service</li><li>G. Warning time greater than 60 seconds attributed to accident-involved train stopping short of the crossing, but within track circuit limits, while warning devices remain continuously active with no other in-motion train present.</li><li>H. Warning time greater than 60 seconds attributed to track circuit failure (e.g., insulated rail joint or rail bonding failure, track or ballast fouled, etc.).</li><li>J. Warning time greater than 60 seconds attributed to other train/equipment within track circuit limits.</li><li>K. Warning time less than 20 seconds attributed to signals timing out before train's arrival at the crossing/island circuit.</li><li>L. Warning time less than 20 seconds attributed to train operating counter to track circuit design direction.</li><li>M. Warning time less than 20 seconds attributed to train speed in excess of track circuit's design speed.</li><li>N. Warning time less than 20 seconds attributed to signal system's failure to detect train approach.</li><li>P. Warning time less than 20 seconds attributed to violation of special train operating instructions.</li><li>R. No warning attributed to signal system's failure to detect the train.</li><li>S. Other cause(s). Explain in Narrative Description.</li></ol>

Figure 73. FRA Accident Report – Page 2 [45]

The FRA website features a query page, which can filter accident report searches, as shown in Figure 74 [46]. To find crossings which caused low ground clearance vehicles to become high-centered, the vehicle position “stalled or stuck on crossing” was selected. A list of accident reports in Nebraska was generated for each year, from 1975 to 2017. Many accident reports did not contain a narrative description, and therefore it was impossible to determine if the vehicle was stalled or became stuck on the crossing.

The screenshot shows the FRA Office of Safety Analysis website. The header includes the FRA logo and the text 'Federal Railroad Administration Office of Safety Analysis'. Below the header is a navigation menu with links: Home, What's New, Crossing, Forms/Publications, Downloads, Data, Documents, Policies, and Support. The main content area is titled '5.15 - Consolidated Hwy Rail Accident Incident'. It contains a search form with the following filters: Reporting Level (All), Railroad (0-9, A, B, C, D, E, F, G, H, I, J, K, L, M, N, O, P, Q, R, S, T, U, V, W, X, Y, Z, All), Sort (Sort by Railroad Name, Sort by Railroad Code), Region (All), State (All), County (All), Type of Crossing (Public & Private), Accident Types (All), Report Type (Calendar Year), Type Of Vehicle (ALL), Position (Stalled or stuck on crossing), Circumstance (ALL), Type of Equipment Consist (ALL), Highway User Action (ALL), Start Month (January), End Month (December), and Year (2017). A note below the filters states 'Accident/Incident data current through the end of April 30, 2017'. At the bottom of the form are two buttons: 'Generate Report' and 'Reset'.

Figure 74. FRA Accident Query [46]

Accident reports featuring tractor-trailers or pickup trucks with trailers becoming high-centered on railroad crossings were considered. Crashes older than 30 years were noted, but dismissed in favor of newer crashes, due to the possibility of the crossing changing over time. From these low ground clearance vehicle crashes, two at-grade crossings, 083312L and 073062Y, were selected for 3D scanning based on information found in the accident reports.

#### 4.4 FRA Safety Map and Google Maps Street View

The FRA created a map labeling every railroad track, station, and crossing in the U.S. as shown in Figures 75 through 78 [47], and this map was utilized to determine highway-rail grade crossing locations. Railroad tracks are indicated in Figures 75 through 78 by red lines. Rail stations are indicated by a red dot, at-grade crossings are indicated by an orange dot, under-grade crossings are indicated by a blue dot, and over-grade crossings are indicated by a purple dot, as seen in Figures 77 and 78.

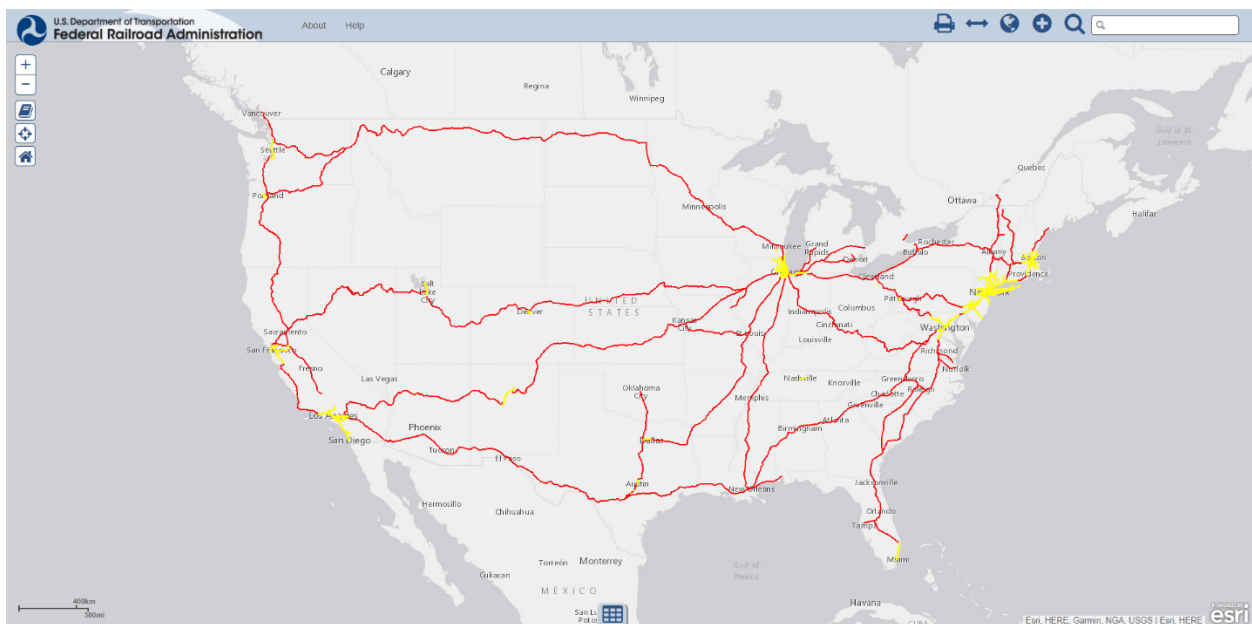

Figure 75. FRA Safety Map of the U.S. [47]

When zoomed in, the colored dots are labeled with either the station name or the crossing identification number, as shown in Figure 78. When clicked, the dot opens a window with crossing information and links to the inventory form and accident reports for the crossing.

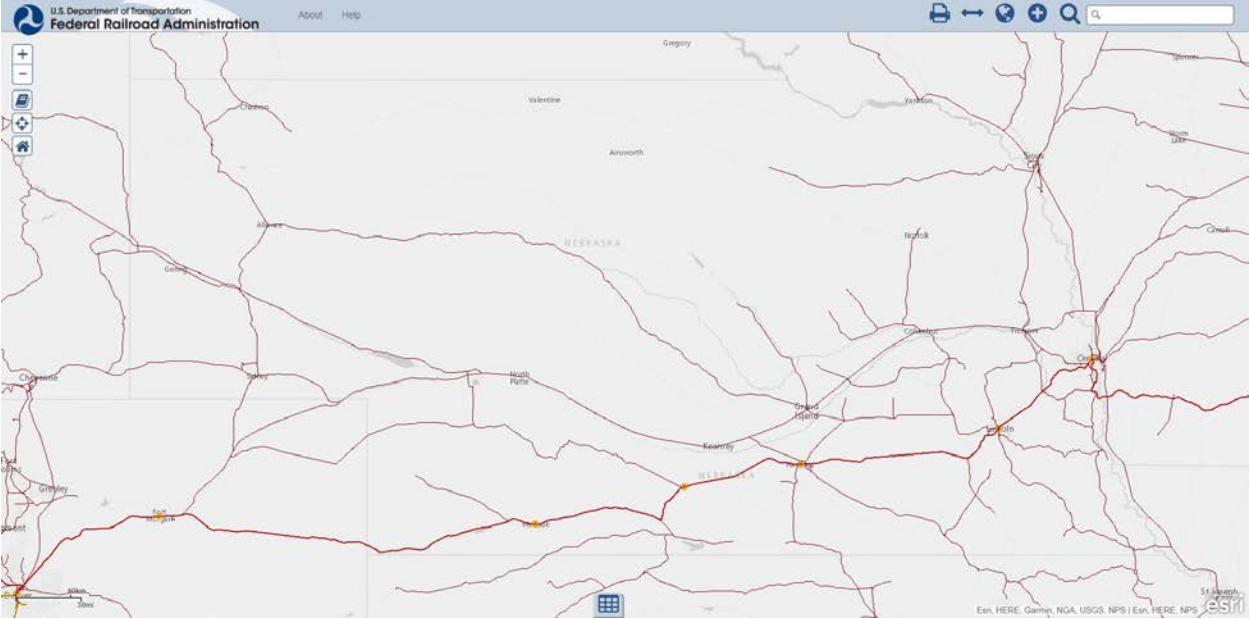

Figure 76. FRA Safety Map of Nebraska [47]

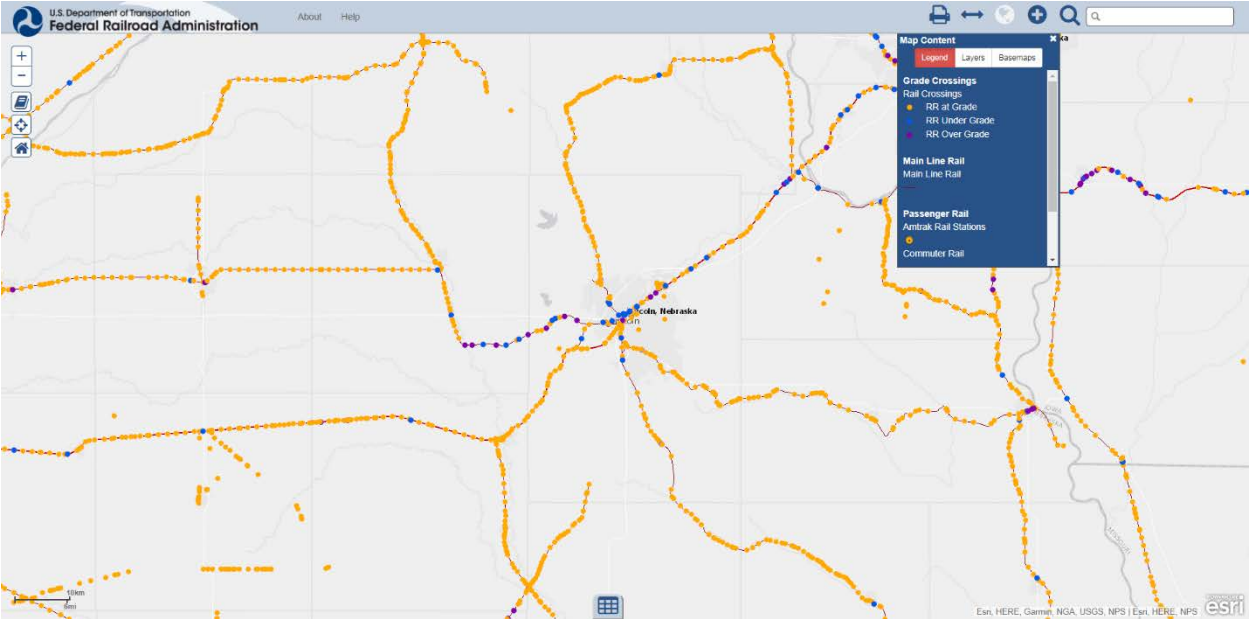

Figure 77. FRA Safety Map of Nebraska with Crossing Locations and Map Legend [47]

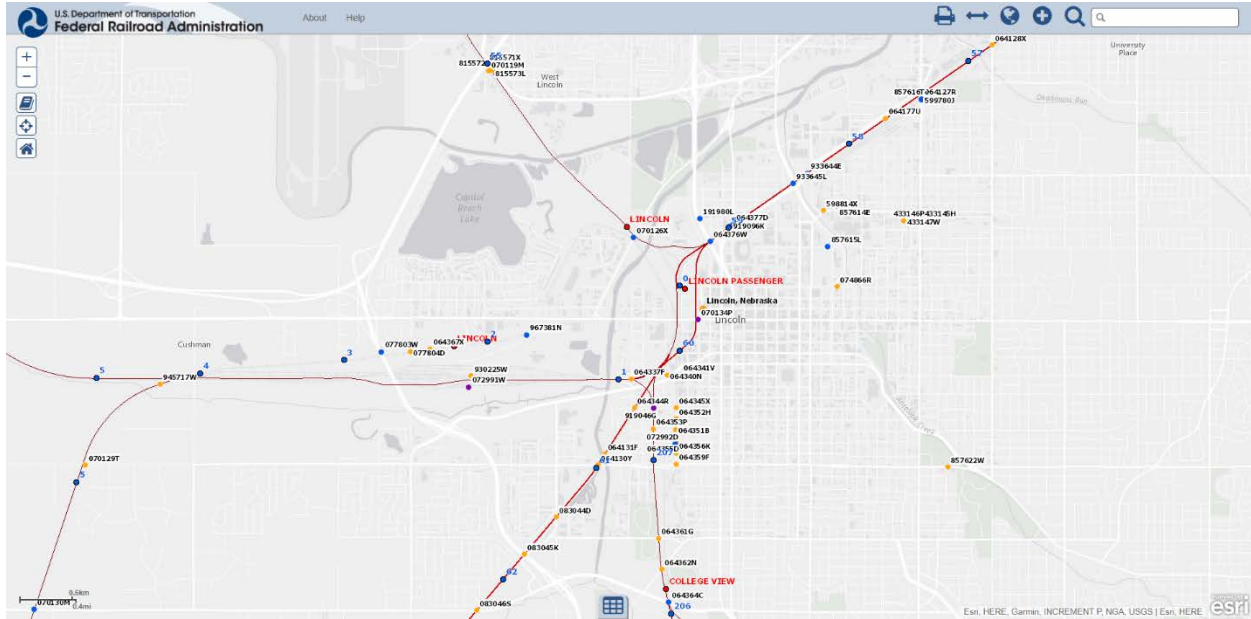

Figure 78. FRA Safety Map of Lincoln, Nebraska with Station and Crossing Labels [47]

The FRA map contains an imagery feature which shows satellite images of crossings, as shown in Figure 79. However, elevation data, track damage or scraping, and surrounding roadways could not be investigated using the zoomed perspective shown in Figure 79. Thus, researchers evaluated alternative methods of evaluating real-world concerns with grade crossing geometries.

For each of the grade crossings within a 200-mile radius of the MwRSF Research Headquarters in Lincoln, Nebraska, researchers evaluated cross roads and grade crossings in greater detail using the Google Maps Street View feature [48]. Crossings were located on both FRA and Google maps, and then analyzed with Google Street View. An example of this process for crossing 073158N is shown in Figures 79 through 82. The highway-rail crossing grade is visible in Figures 80 and 81, and scrape marks on the crossing are visible in Figure 82. Using this method, multiple crossings with visual indications of scraping at the grade crossing were advanced for further consideration.



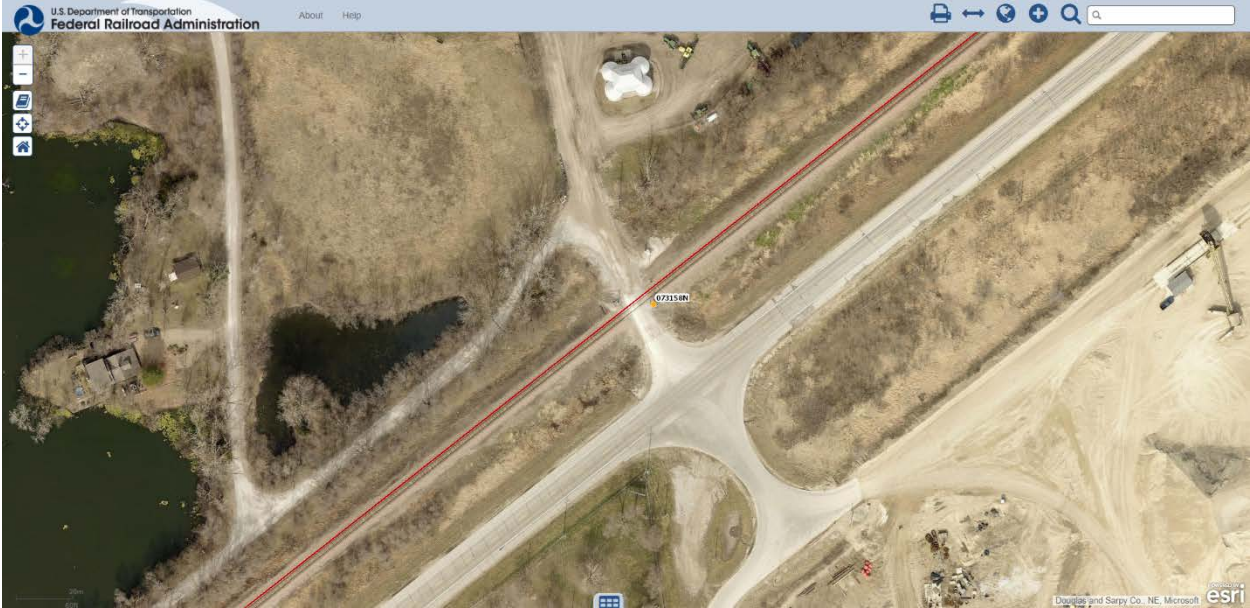

Figure 79. FRA Safety Map of Crossing 073158N at Maximum Zoom [47]



Figure 80. Google Street View of Highway-Rail Grade at Crossing 073158N [49]





Figure 81. Google Street View of Highway-Rail Grade at Crossing 073158N [49]



Figure 82. Google Street View of Scrape Marks on Crossing 073158N [49]

**4.5 Crossings Selected for 3D Scanning**

A total of seven highway-rail grade crossings were selected for 3D scanning based on accident reports, Google Street View images, and recommendations from NDOT.

#### **4.5.1 Crossing 083312L**

Crossing 083312L was selected based on an FRA accident report. On March 4, 2013 a tractor-trailer became high-centered on crossing 083312L, located on an unpaved road near Tecumseh, Nebraska. According to the inventory form completed on March 4, 2016, this crossing is owned by Burlington Northern Santa Fe (BNSF) railway, carries 22 trains per day, sees on average 110 vehicles per day, and 18 percent, or 20 of those vehicles, are trucks. No low ground clearance sign is posted at the crossing. The 2013 accident report is shown in Figure B-5, two older accident reports are shown in Figures B-6 and B-7, and the inventory form is shown in Figures A-5 and A-6.

#### **4.5.2 Crossing 073062Y**

Crossing 073062Y was selected based on an FRA accident report. On August 4, 2005 a lowboy trailer became high centered on crossing 073062Y, a paved private crossing located near Bellevue, Nebraska. According to the inventory form completed on March 4, 2016, this crossing is owned by BNSF and carries 23 trains per day. The form did not include a daily vehicle count and indicates traffic is 0 percent trucks. No low ground clearance sign is posted at the crossing. The accident report is shown in Figure B-1, and the inventory form is shown in Figures A-1 and A-2.

#### **4.5.3 Crossing 073158N**

This crossing was selected due to the steep grade and scrape marks on the asphalt which were observed using Google Street View. It is located near Ashland, Nebraska. According to the inventory form completed on March 4, 2016, this crossing is owned by BNSF, carries 21 trains per day, sees on average 235 vehicles per day, and 9 percent, or 21 vehicles, are trucks. No low ground clearance sign is posted at the crossing. Three older accident reports are shown in Figures B-2, B-3, and B-4 and the inventory form is shown in Figures A-3 and A-4.

#### **4.5.4 Crossing 817404F**

Crossing 817404F was selected due to scrape marks on the asphalt which were observed using Google Street View. It is in Bellevue, Nebraska near multiple automobile dealerships. Due to the location, there is a possibility of auto-transport trailers traversing the crossing. According to the inventory form completed on May 8, 2017, crossing 817404F is owned by UP, carries 5 trains per day, sees on average 200 vehicles per day, and 3 percent, or 6 vehicles, are trucks. No low ground clearance sign is posted at the crossing. There are no accident reports for this crossing and the inventory form is shown in Figures A-9 and A-10.

#### **4.5.5 Crossing 817405M**

Crossing 817405M was selected due to scrape marks on the asphalt which were observed using Google Street View. It is in Bellevue, Nebraska near multiple automobile dealerships. Due to the location, there is a possibility of auto-transport trailers traversing the crossing. According to the inventory form completed on November 14, 2016, crossing 817405M is owned by UP, carries 5 trains per day, sees on average 200 vehicles per day, and 1 percent, or 2 vehicles, are trucks. No low ground clearance sign is posted at the crossing. There are no accident reports for this crossing and the inventory form is shown in Figures A-11 and A-12.

#### **4.5.6 Crossing 816134F**

Crossing 816134F was selected due to scrape marks on the asphalt which were observed using Google Street View. It is in Bellevue, Nebraska near multiple automobile dealerships. Due to the location, there is a possibility of auto-transport trailers traversing the crossing. According to the inventory form completed on November 14, 2016, crossing 816134F is owned by UP, carries 5 trains per day, sees on average 300 vehicles per day, and 3 percent, or 9 vehicles, are trucks. No low ground clearance sign is posted at the crossing. There are no accident reports for this crossing and the inventory form is shown in Figures A-13 and A-14.

#### **4.5.7 Crossing 083410C**

NDOT was notified of our intent to scan railroad crossings and recommended an additional site, crossing 083410C, located in Hampton, Nebraska which has caused multiple lowboy trailers to become high-centered. One incident resulted in the trailer pulling up the buffer between the railroad ties. According to the inventory form completed on April 19, 2016, crossing 083410C is owned by BNSF, carries 30 trains per day, sees on average 460 vehicles per day, and 9 percent, or 41 vehicles, are trucks. No low ground clearance sign is posted at the crossing. There are no accident reports for this crossing and the inventory form is shown in Figures A-7 and A-8.

### **4.6 Field Survey**

#### **4.6.1 Permission to 3D Scan Crossings**

Permission from the operating railroad company needed to be acquired before traveling to and scanning the crossings. In addition, the local police and the Nebraska State Patrol (NSP) were contacted. Crossings 817404F, 817405M, and 816134F are owned by UP and were 3D scanned on September 26, 2017. To scan the UP crossings, a nonintrusive survey permit was obtained and is shown in Figures 83 through 86. The permit does not allow vehicles or equipment on railroad property. As per the permit instructions, a copy of the permit was on hand while at the crossing sites. Prior to traveling to the crossing locations, the permit required the local manager of track maintenance be notified of the plans and dates for scanning the crossings. Bellevue Police and NSP were also notified before crossings 817404F, 817405M, and 816134F were 3D scanned.



**PERMIT TO BE ON RAILROAD PROPERTY  
FOR NONINTRUSIVE CIVIL ENGINEERING SURVEY WORK**

Date: September 5, 2017

Name of Company: Midwest Roadside Safety Facility – University of Nebraska-Lincoln

Please note this permit **DOES NOT** allow for the use of vehicles or machinery on the railroad property.

This is not a permit for installation, maintenance of existing facilities, or working within UP right of way. If it is your or your client's intent to do any of the preceding, you must apply for and obtain the appropriate license agreement. Applications for Right of Entry, Utility Crossings or Encroachments (parallel occupancies) for this location should be made by submitting an online application. Please visit our website at: <http://www.uprr.com/reus/index.shtml> and follow the instructions included there.

**YOU MUST GIVE ADVANCE NOTICE TO THE LOCAL MANAGER OF TRACK MAINTENANCE LISTED BELOW AND COMPLY WITH ANY INSTRUCTIONS GIVEN; AND AGREE TO REIMBURSE RAILROAD FOR ANY COSTS (E.G. FLAGGING) PRIOR TO ENTERING PROPERTY:**

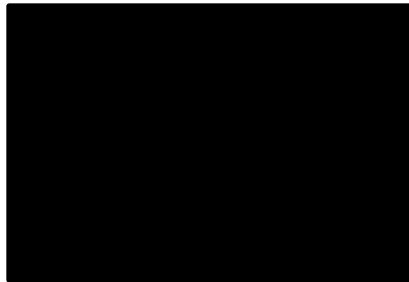

**ANY INDIVIDUAL ENTERING RAILROAD PROPERTY MUST KEEP A FULLY EXECUTED COPY OF THIS SURVEY PERMIT IN HIS/HER POSSESSION AT ALL TIMES WHILE ON RAILROAD PROPERTY. IT MUST BE PRESENTED TO ANY RAILROAD EMPLOYEE REQUESTING EVIDENCE OF PERMISSION TO BE ON RAILROAD PROPERTY.**

Figure 83. UP Nonintrusive Survey Permit – Page 1





**PERMIT TO BE ON RAILROAD PROPERTY  
FOR NONINTRUSIVE CIVIL ENGINEERING SURVEY WORK**

**RECITALS:**

The undersigned party seeking permission to be on Railroad property is hereinafter called "Permittee". Due to the nature of Railroad operations, Railroad property can be a dangerous place for people and/or property. Railroad's safety rules and practices shall be strictly observed and followed at all times while on Railroad property.

WHEREAS, Permittee desires to obtain temporary permission to enter and be on or about the tracks and/or property of the **UNION PACIFIC RAILROAD COMPANY** (hereinafter called "Railroad"), for the purpose of performing nonintrusive civil engineering survey work, without the use of vehicles and/or machinery on Railroad's property; and

WHEREAS, the Railroad is willing to allow the Permittee temporary permission to be on or about its premises for the purpose aforesaid on the terms and conditions stated herein:

NOW THEREFORE, Railroad grants to Permittee temporary permission to be on or about the tracks and/or property of the Railroad for the purpose above stated, subject to the following conditions:

1. Before exercising any privilege under the permission herein given, Permittee shall contact the Railroad Superintendent's office having jurisdiction over the property involved.
2. Permittee shall become familiar with and strictly observe Railroad's safety rules and all other rules, regulations, or directions of Railroad's Superintendent or his representatives.
3. Permittee shall agree to the terms and conditions of this instrument, and shall so evidence by his execution of same.
4. The above recited permission is granted solely upon the condition that Permittee shall and hereby does agree to indemnify, protect and save harmless, Railroad from any and all loss or damage that Railroad may sustain or become liable for, caused by, resulting from, or by reason of any injury to or death of any persons whomsoever, or destruction of property of any kind to whomsoever belonging, howsoever suffered or caused, regardless of whether caused solely or contributed to in part by the negligence or fault of the Railroad, in or incident to or in connection with the aforesaid work on Railroad's property hereinabove referred to. Public Agencies shall indemnify Railroad as herein described to the extent allowed by law.
5. Upon completion of your work, but in no event later than the last day of the term of this agreement, Permittee will remove all of his tools, equipment, and other property of any kind whatsoever, and restore Railroad's property to substantially the same condition that existed prior to the performance of your work hereunder.
6. This permit may be revoked at any time by the Railroad, but if not revoked shall expire at the end of the last date written below.

PLEASE complete the following information and execute in the space marked "By". You should then email this application long with a map of the location to [recontracts@up.com](mailto:recontracts@up.com). Alternatively, for a \$100.00 administrative fee, you may mail the application and map with the fee to the address listed below. (Faxed applications are not accepted.) After execution on behalf of the Railroad Company, one copy will be returned to you. You must KEEP your fully-executed copy in your possession at all times while on Railroad property. It MUST be shown on request to any Railroad employee or official.

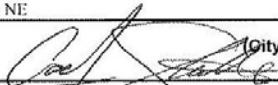
Your Company Name: Midwest Roadside Safety Facility, University of Nebraska-Lincoln  
 Your Client's Name: N/A  
 Street Address: 130 Prem S Paul Research Center at Whittier School, 2200 Vine Street  
 City, State, Zip: Lincoln, NE 68583-0853  
 Phone: 402-472-4233 Fax: 402-472-2022  
 Email: estolle2@unl.edu  
 Purpose of Survey: Collect topographical, visual survey of rail grade crossing sites to generate 3D simulation models. Purpose is to predict when large truck-trailer combinations are at higher risk for scraping or becoming high-centered. No vehicles will be used on rail right-of-way except at roadway shoulders (public crossing); roadside cones & vests will be used.  
 Date Work to Begin: 8/28/2017 Ending: 9/27/2017  
 (30-day max.)  
 Location of Survey: Grade Crossings 816134F, 817404F, and 817405M  
Bellevue, NE  
 (City, State/Lat Long)  
 BY:   
 Printed Name and Title: Cody Stolle  
 Date: August 24, 2017

**UNION PACIFIC RAILROAD COMPANY**  
  
 BY: \_\_\_\_\_  
 Title: \_\_\_\_\_  
 Real Estate - Contracts  
 Union Pacific Railroad Company  
 1400 Douglas St. – STOP 1690  
 Omaha, NE 68179  
 Phone: (402) 544-8600

**FAXED APPLICATIONS  
ARE NOT ACCEPTED**

Figure 84. UP Nonintrusive Survey Permit – Page 2





Figure 85. UP Nonintrusive Survey Permit – Page 3

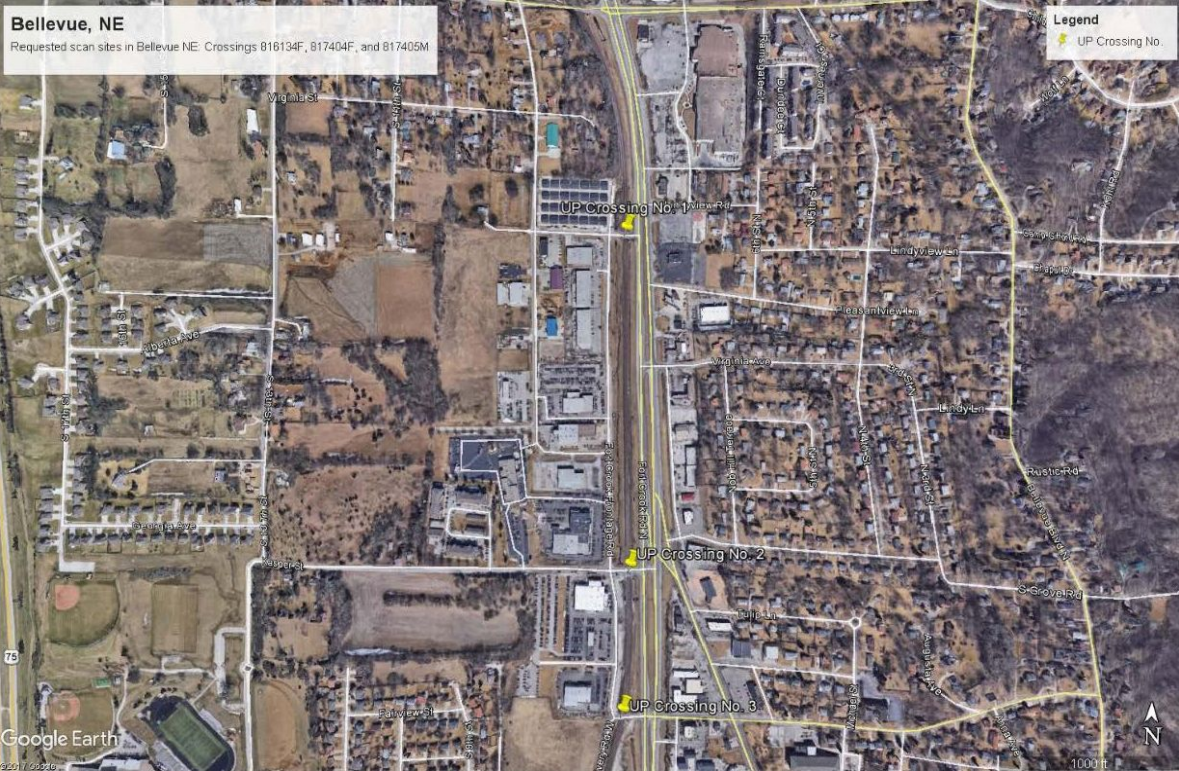

Figure 86. UP Nonintrusive Survey Permit – Page 4



#### **4.7 Procedure for 3D Scanning Crossings**

The Nebraska Transportation Center (NTC) provided MwRSF with a trailer that had an extendable pole attachment for scanning the crossings, as shown in Figure 87. The pole extends 15 ft (4.6 m) in the air. A mounting device for the Faro Focus X130 scanner was manufactured by MwRSF. The mount attaches to the top of the pole and allows the Faro scanner to be mounted upside down. The inverted attachment was necessary because the scanner has a blind zone extending conically around its mounting position. Thus, inverting the scanner allows ground data to be collected and places the blind zone above the scanner, toward the sky. Furthermore, mounting the scanner 15 ft (4.6 m) in the air allows the scanner to collect data over a larger area. The trailer, with the extendable pole raised and the scanner mounted, is shown in Figure 88.

Setting up the trailer and scanner at each site involved extending the pole attachment in the horizontal position, attaching the 3D scanner to the mount, and raising the pole into the air via a hydraulic jack. Locating spheres were placed near the crossing, which are used to register scans taken at the same crossing site but at different locations around the crossing. Traffic cones were set up around the vehicle and trailer, and reflective vests were worn by all personnel involved, as shown in Figure 89.

At each crossing location, a total of four scans were taken. Two scans were taken in each of the two corners that did not house the crossing arms.



Figure 87. NTC Trailer with Extendable Pole



Figure 88. NTC Trailer with Faro 3D Scanner Mounted and Extendable Pole Raised

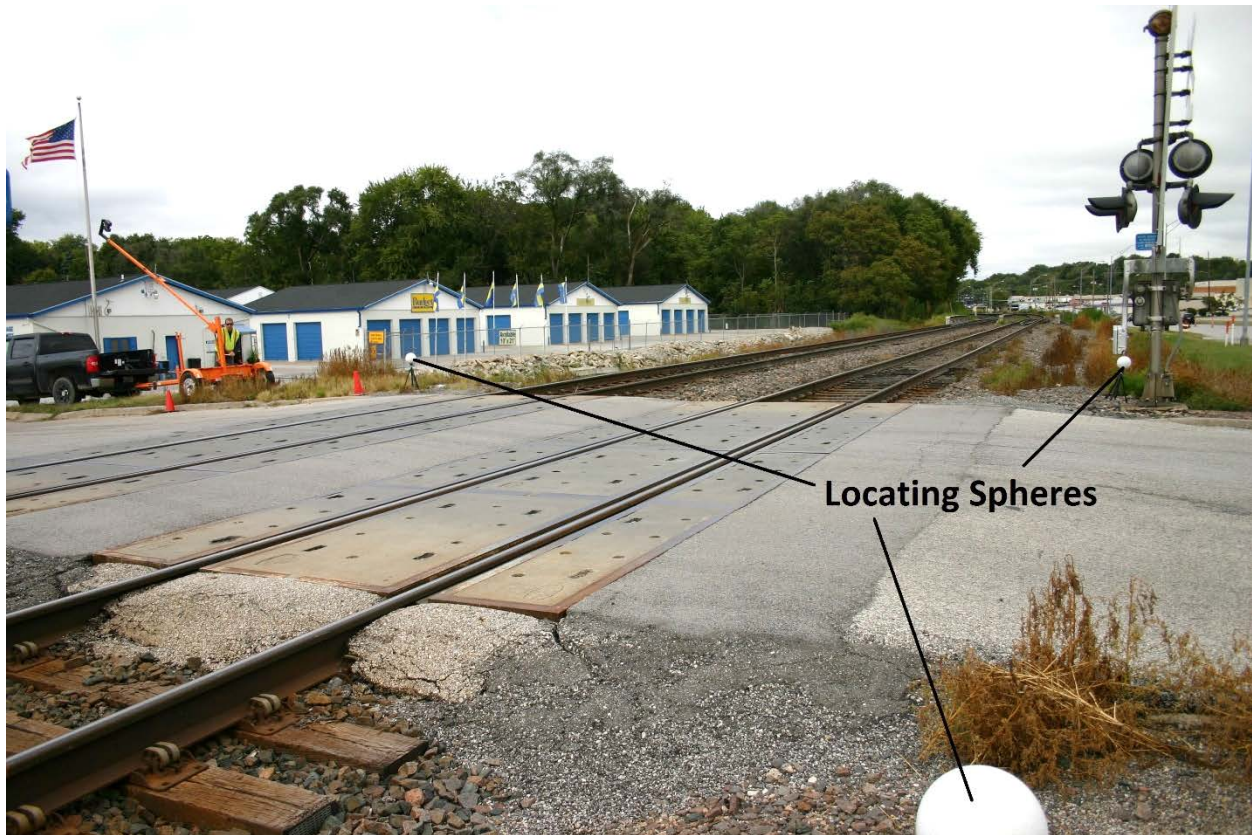

Figure 89. Locating Spheres, Traffic Cones, and Reflective Scanning Setup

#### **4.7.1 Scanning Crossing 817404F**

Crossing 817404F, located on Kasper Street, was the first crossing scanned on September 26, 2017 and is shown in Figures 90 through 92. This crossing appeared flat and did not have any scrape marks on the asphalt. While scanning the crossing, a semi-truck and trailer traversed the crossing. The truck stopped at the stop sign before turning onto Fort Crook Road, and while stopped the trailer was parked over the railroad tracks. This problem of inadequate space for trucks at crossings is not the focus of this research, but is an important issue.





Figure 90. Crossing 817404F



Figure 91. West Approach of Crossing 817404F



Figure 92. East Approach of Crossing 817404F

#### **4.7.2 Scanning Crossing 817405M**

Crossing 817405M, located on Avery Road, was the second crossing scanned and is shown in Figure 93. This crossing appeared somewhat steep and scrape marks are visible on the east approach, as shown in Figures 94 and 95. On the west approach, the crossing panels and roadway are not level, as shown in Figures 96 and 97.





Figure 93. Crossing 817405M



Figure 94. East Approach of Crossing 817405M with Scrape Marks on the Asphalt





Figure 95. East Approach of Crossing 817405M with Scrape Marks on the Asphalt, Close Up



Figure 96. West Approach of Crossing 817405M with Uneven Crossing Surface





Figure 97. West Approach of Crossing 817405M with Uneven Crossing Surface, Close Up

#### **4.7.3 Scanning Crossing 816134F**

Crossing 816134F, located on Cary Street, was the last crossing scanned and is shown in Figure 98. This crossing is steep and scrape marks are visible on both approaches, shown in Figures 99 through 102. While scanning the crossing, an auto transport trailer traversed the crossing. Though scraping could not be heard as the trailer crossed the tracks, the bottom of the trailer was observed to have minimal clearance to the roadway asphalt. Researchers did not anticipate the crossing of the auto transport and did not collect photographs in transit.





Figure 98. Crossing 816134F



Figure 99. West Approach of Crossing 816134F with Scrape Marks on the Asphalt





Figure 100. West Approach of Crossing 816134F with Scrape Marks on the Asphalt, Close Up



Figure 101. East Approach of Crossing 816134F with Scrape Marks on the Asphalt





Figure 102. East Approach of Crossing 816134F with Scrape Marks on the Asphalt, Close Up

#### **4.8 Results of 3D Scanning**

The computer program Scene was utilized to register, or align, the scans from each crossing. Once registered, measurements were taken from the 3D model using the program FARO Zone.

##### **4.8.1 Accuracy of Scans**

The accuracy of the 3D scans was determined by comparing known dimensions to dimensions measured in the three scans. Three measurements were taken from the 816134F crossing scan: the diameter of the grade crossing advance warning sign (W10-1), the width of the stop sign (R1-1), and the length of the crossbuck sign (R15-1), shown in Figure 103. In addition, the diameter of the W10-1 sign was measured in both the 817404F and 817405M crossing scans.



Figure 103. Measured Dimensions on W10-1 (left), R1-1 (middle), and R15-1 (right) Signs

Measured dimensions, actual dimensions [9], and percent errors for the three scans are shown in Table 9. The percent errors between the actual and the measured distances were small, with a maximum error of 3.6 percent. Therefore, the scans represent to-scale models of the three crossings and measurements taken from them were believed to be accurate.

Table 9. Measured Dimensions, Actual Dimensions, and Percent Error for 3D Scans

Scan	Sign	Measured Width in. (mm)	Actual Width in. (mm)	Percent Error
816134F	W10-1	34.94 (887)	36.00 (914)	2.95
816134F	R1-1	36.44 (926)	36.00 (914)	1.22
816134F	R15-1	46.30 (1176)	48.00 (1219)	3.55
817404F	W10-1	35.17 (893)	36.00 (914)	2.31
817405M	W10-1	35.15 (893)	36.00 (914)	2.37

#### 4.8.2 Crossing 817404F

The results of the 3D scans are shown in Figures 104 through 106. Slope measurements were used to evaluate road grades adjacent to the crossings, and a comparison of the results of the road section with the AASHTO/AREMA (2015) geometric design recommendations [8] is shown in Figure 107. The approach slope has a grade of 1.80 percent and a track elevation of 5.44 in. (138 mm). The departure slope has a grade of 3.00 percent and a track elevation of 8.95 in. (227



mm). Based on the results of the slope and height analysis, crossing 817404F is not within the recommended AASHTO/AREMA (2015) grade crossing guidelines.

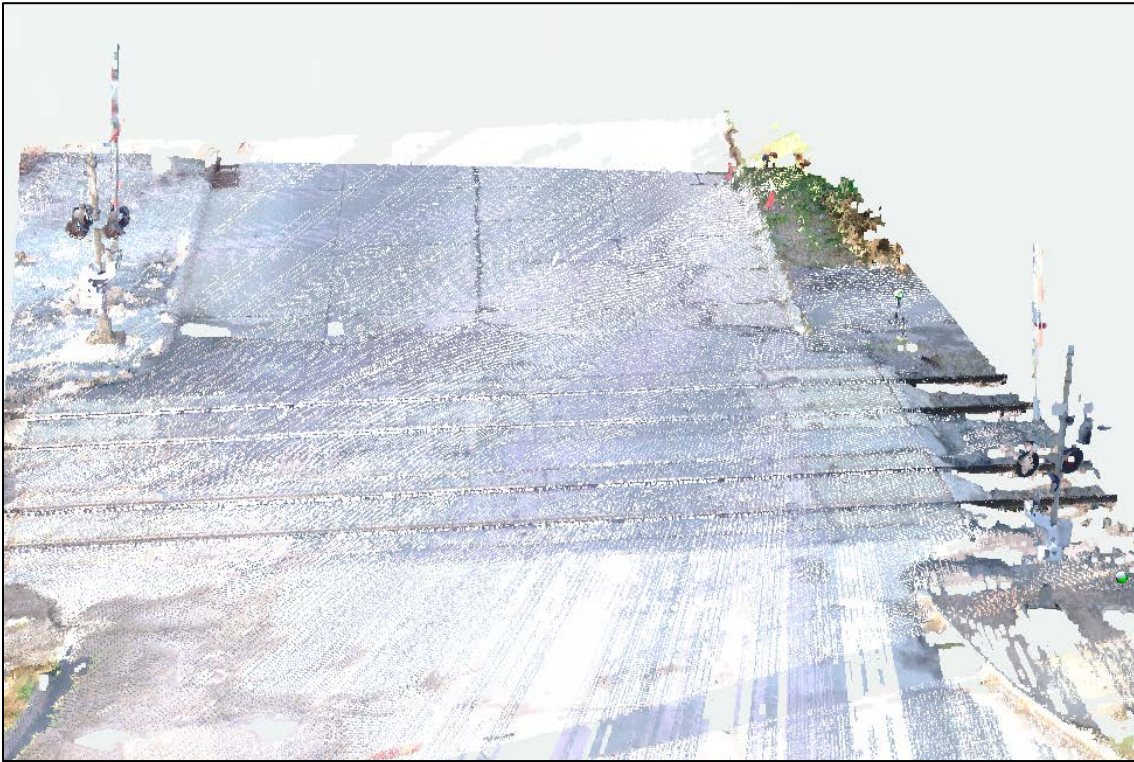

Figure 104. Crossing 817404F FARO Scan Front View

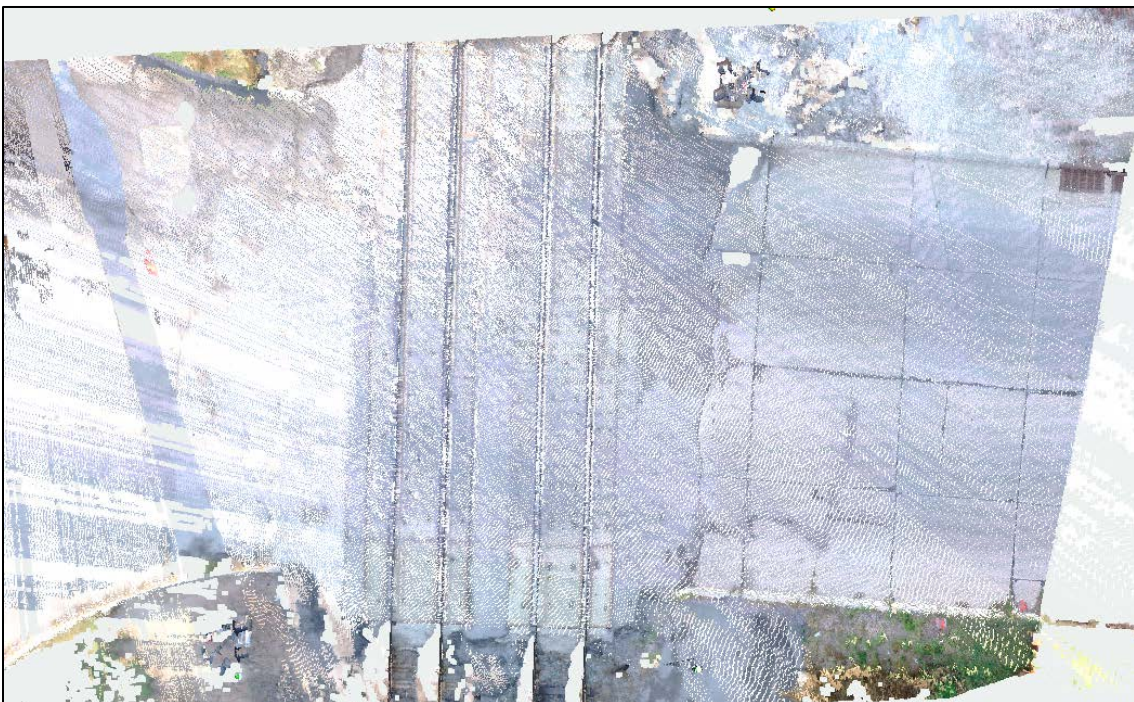

Figure 105. Crossing 817404F FARO Scan Top View



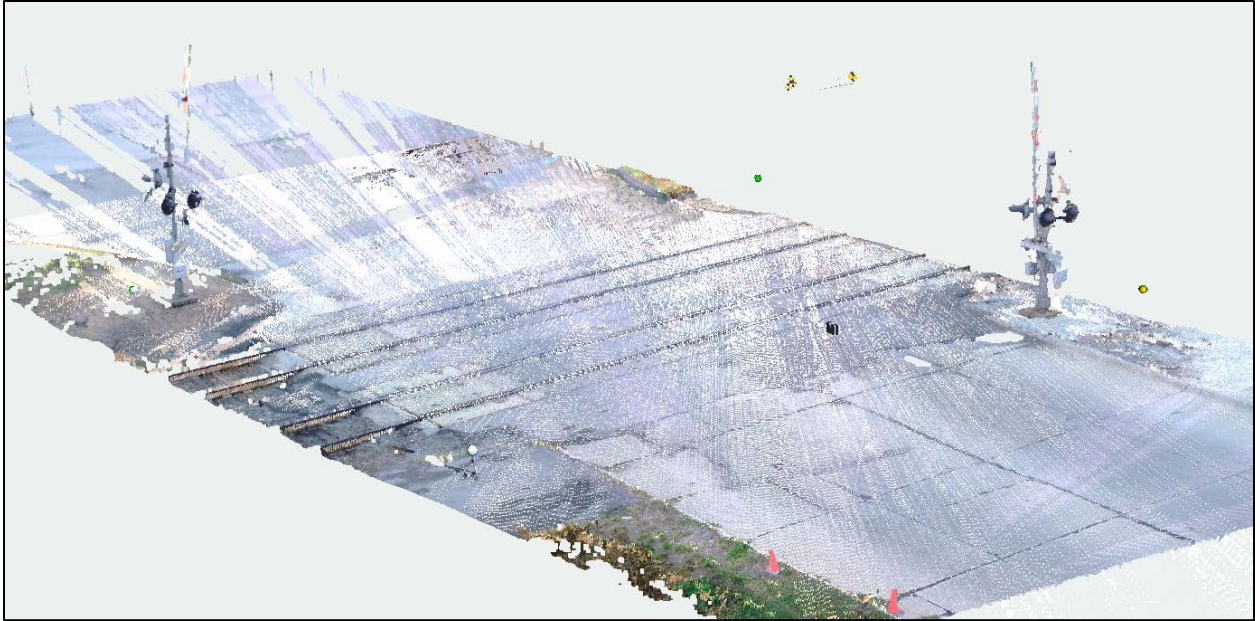

Figure 106. Crossing 817404F FARO Scan Angled View

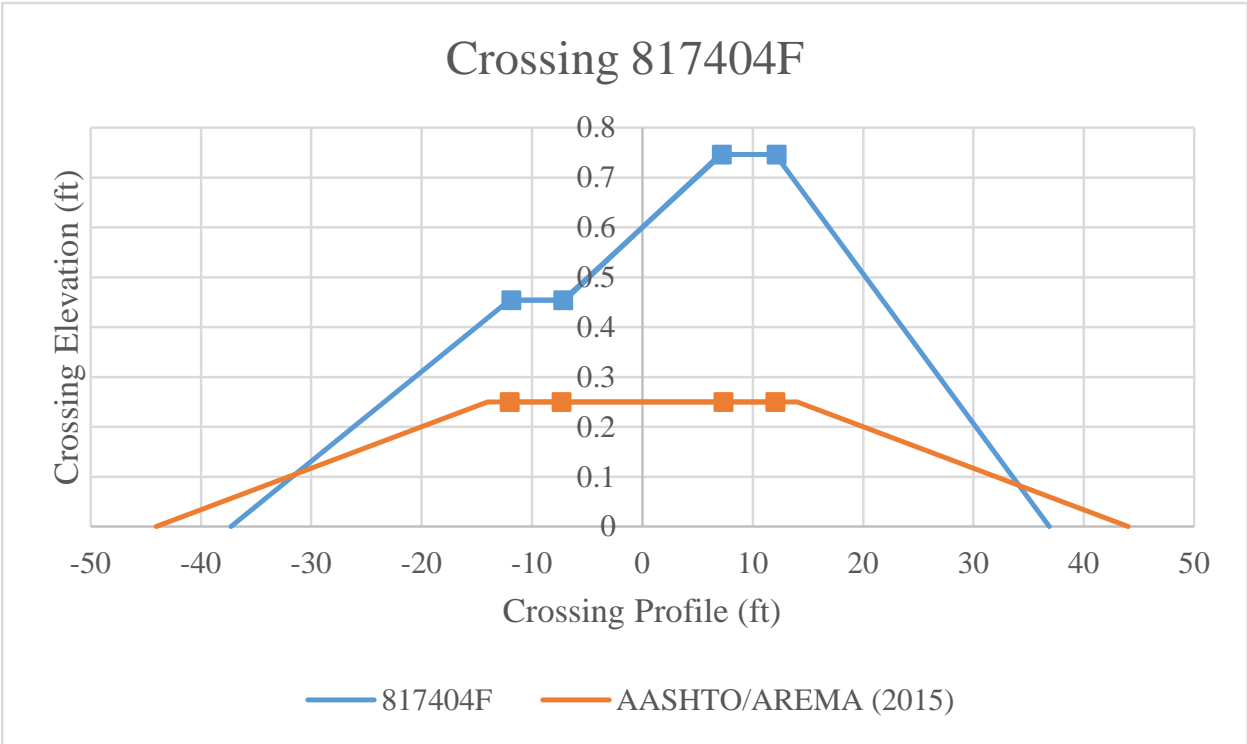

Figure 107. Crossing 817404F Profile Compared to the AASHTO/AREMA (2015) Guidelines

**4.8.3 Crossing 817405M**

The results of the 3D scans are shown in Figures 108 through 110. A comparison of in-lane slope profiles of the track and the AASHTO/AREMA (2015) guidelines is shown in Figure



111. The approach slope has a grade of 2.88 percent and a track elevation of 8.69 in. (221 mm). The departure slope has a grade of 4.08 percent and a track elevation of 12.24 in. (311 mm). Based on slope and elevation results, crossing no. 817405M is not within the recommendations provided by AASHTO/AREMA (2015).



Figure 108. Crossing 817405M FARO Scan Front View





Figure 109. Crossing 817405M FARO Scan Top View



Figure 110. Crossing 817405M FARO Scan Angled View

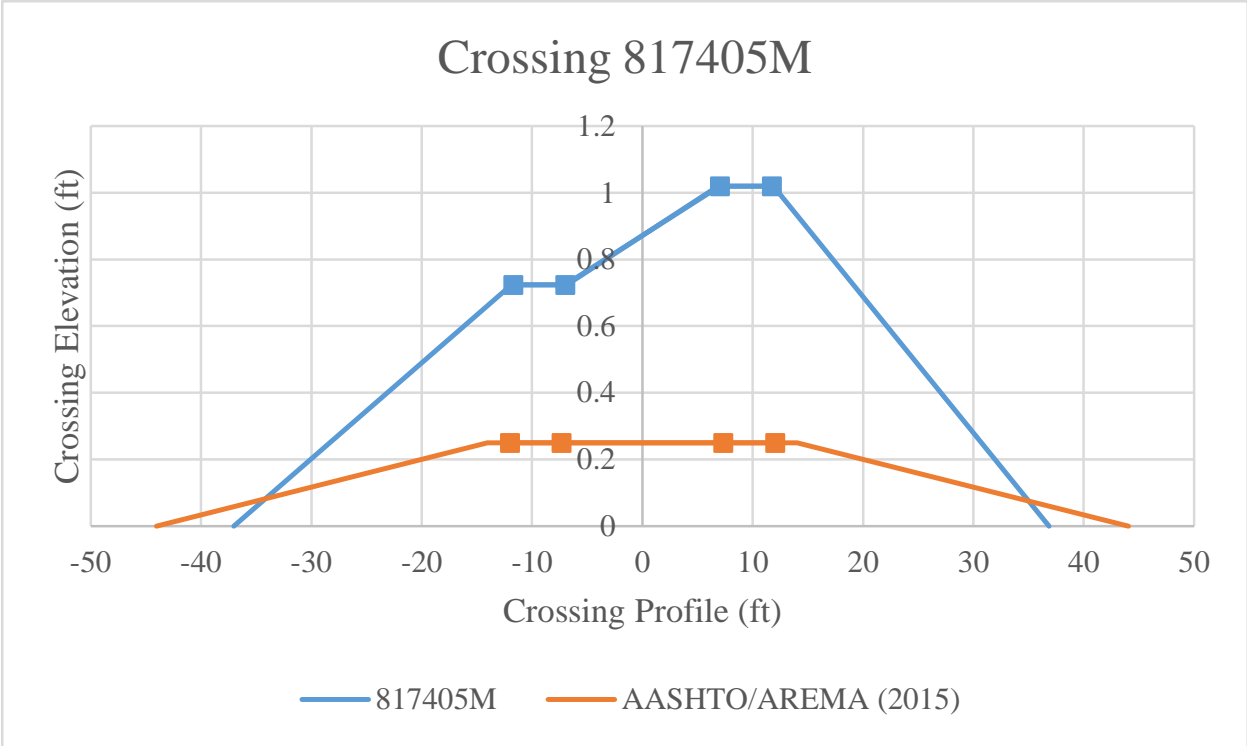

Figure 111. Crossing 817405M Profile Compared to the AASHTO/AREMA (2015) Guidelines

**4.8.4 Crossing 816134F**

The results of the 3D scans are shown in Figures 112 through 114. Slope and elevations of the track determined using results of the 3D scan data was compared with ASHTO/AREMA (2015) guidelines, as shown in Figure 115. The approach slope has a grade of 2.88 percent and a track elevation of 8.70 in. (221 mm). The departure slope has a grade of 1.32 percent and a track elevation of 3.96 in. (101 mm). Based on slope and elevation measurements, crossing no. 816134F is not within the recommended guidelines provided by AASHTO/AREMA (2015).





Figure 112. Crossing 816134F FARO Scan Front View

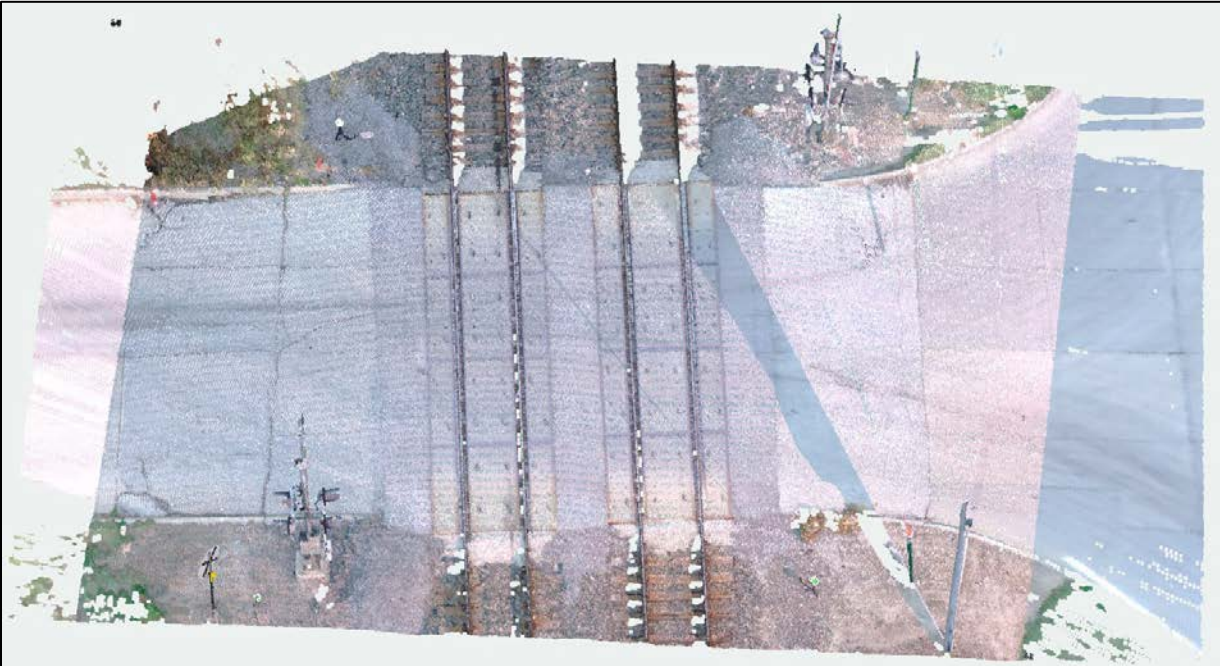

Figure 113. Crossing 816134F FARO Scan Top View



Figure 114. Crossing 816134F FARO Scan Angled View

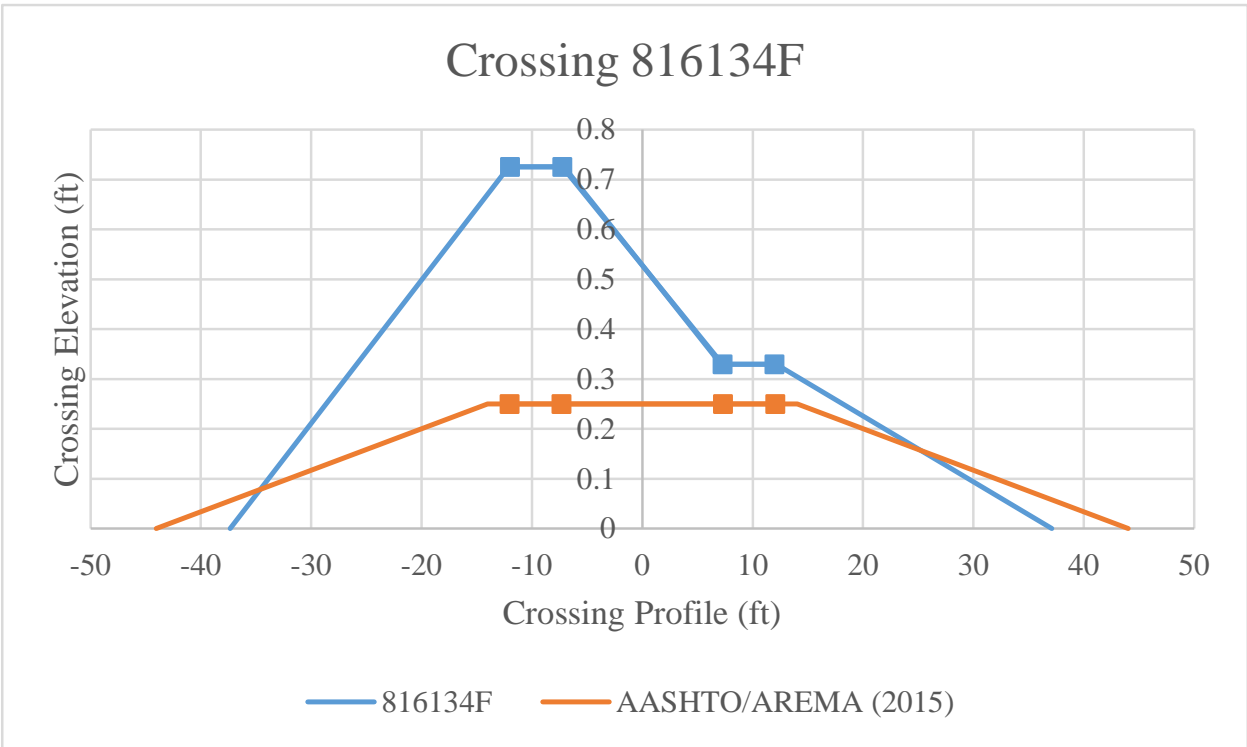

Figure 115. Crossing 816134F Profile Compared to the AASHTO/AREMA (2015) Guidelines

**4.9 Findings**

All three railroad crossings that were 3D scanned were steeper and taller than AASHTO/AREMA (2015) recommended highway-rail grade crossing guidelines. Crossings

817405M and 816134F have scrape marks due to the underside of vehicles and trailers contacting the crossing surface. Crossings 817405M and 816134F have elevations approximately 0.45 ft (137 mm) and 0.75 ft (229 mm) greater than the guidelines, respectively. Crossing 817404M did not have scrape marks on the crossing, but was elevated approximately 0.5 ft (152 mm) above the guidelines. None of the surveyed crossings had signs warning low-ground clearance vehicles of a tall grade crossing.

#### **4.10 Site Observations and Real-World Problems**

Five automobile dealerships are located near the three 3D scanned crossings. It is reasonable to assume the crossings are traversed by auto transport trailers, which can have wheelbases of 42 ft (12.8 m) and ground clearances of 4 in. (102 mm). Although no FRA accident reports have been filed for these crossings, there are still prevailing concerns for safety. Note that an FRA accident report would only be filed if a train-vehicle collision occurred. Despite no crashes at these locations in the past, the potential for vehicles becoming high-centered still exists.

#### **4.11 Additional Discussion Regarding BNSF Crossings**

Although rail grade crossing nos. 083312L, 073158N, 073062Y, and 083410C were of interest to researchers, all grade crossings owned by BNSF required extensive negotiation to perform visual site surveys. Limitations on project time and budget were determined to outweigh the benefits of conducting research at these sites. Researchers recommend a thorough understanding of the complications associated with site surveying at grade crossings before attempting to perform on-site inspection. Alternative methods to evaluate grade crossing geometries, elevations, and configurations, if available, are highly recommended.

#### **4.12 Summary**

Multiple grade crossings near the MwRSF Headquarters in Lincoln, Nebraska, were evaluated using the grade crossing inventory and Google Earth inspection. Several of these grade



crossings were associated with either historical crash reports, anecdotal evidence of scraping or collision, or susceptibility due to high truck traffic. Three sites were investigated using optical survey measurements (LIDAR using the FARO Focus X130), each owned by Union Pacific. Inspection and slope measurements were used to evaluate track geometries, and unfortunately, each grade crossing was determined to be steeper and taller than the recommended limits provided by AASHTO/AREMA (2015). However, none of the tracks which were surveyed had experienced any truck-train crashes.

Researchers recommend identification of potentially problematic grade crossing geometries using visual inspection techniques described in this report. These techniques could greatly reduce the cost associated with site inspection and may be performed remotely by any party with access to satellite images, street-view images, and the rail crossing inventory. High-profile crossings could be identified and evaluated, and markings or signs could be placed to warn drivers of low, long wheelbase vehicles of the potential danger.

The elevated crossing profiles may be due to maintenance performed by the railroad company, but this cannot be definitively determined. These three crossings profiles were modeled in TruckSim to determine which vehicle dimensions resulted in the vehicle becoming high-centered. The results of the simulations are discussed in Chapter 8.

## **5 TRACK MAINTENANCE AND REPAIRS**

### **5.1 Introduction**

Researchers denoted that there were several grade crossings evaluated with a site survey, crash reporting, and observation which did not satisfy the geometry recommendations provided by AASHTO/AREMA (2015). Researchers attempted to determine why grade crossings did not satisfy recommendations for grade crossing construction. This limited investigation consisted of a review of property rights and ownership (i.e., jurisdiction), maintenance practices and responsibilities, and the coordination of railroad companies with transit authorities. Results of this investigation are provided below. It should be noted that results are anecdotal, and should be explored in detail in future studies.

### **5.2 Grade Crossing Jurisdiction**

In the U.S., all grade crossings fall under the jurisdiction of railroad companies. The U.S. government provided generous land grants to railroad companies in the 19<sup>th</sup> century to encourage railroad growth, and therefore municipal growth on rail lines, in the western portion of the country. Roberts [50] provides a thorough review of railroad land granting and right-of-way litigation. Eventually, federal land grant practices changed, and as automobile traffic increased, the number of miles of railroad maintained by railroad companies fell, as shown in Figure 116 [10].

As of 2005, approximately 61% of railroad grade crossings were located at rural roadways, and 39% were located at urban roadways, as shown in Figure 117 [10]. However, only 4.8% of grade crossings were located at freeways, highways, or principal arterials, nearly 30% were located at minor arterials and collector roads, and 65% were located at roads classified as local, unreported, or other, as shown in Figure 118. It should also be noted that unreported and other road categories constituted less than 1% of the grade crossings.

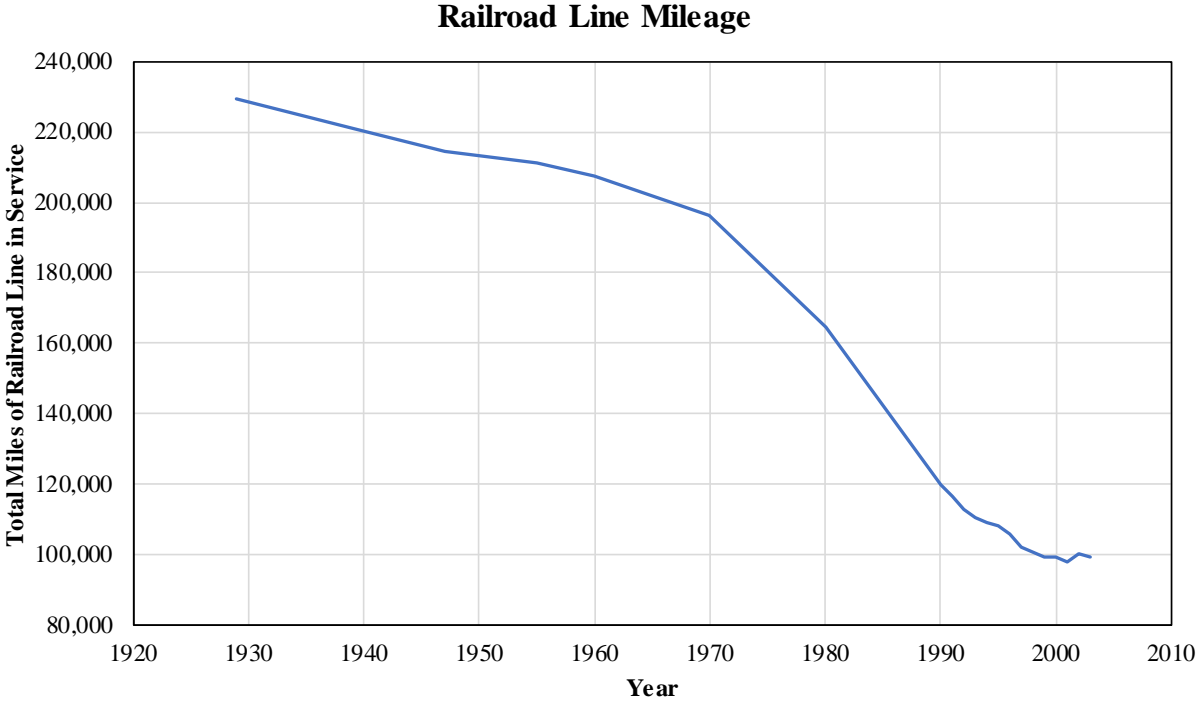

Figure 116. Railroad Line Mileage [10]

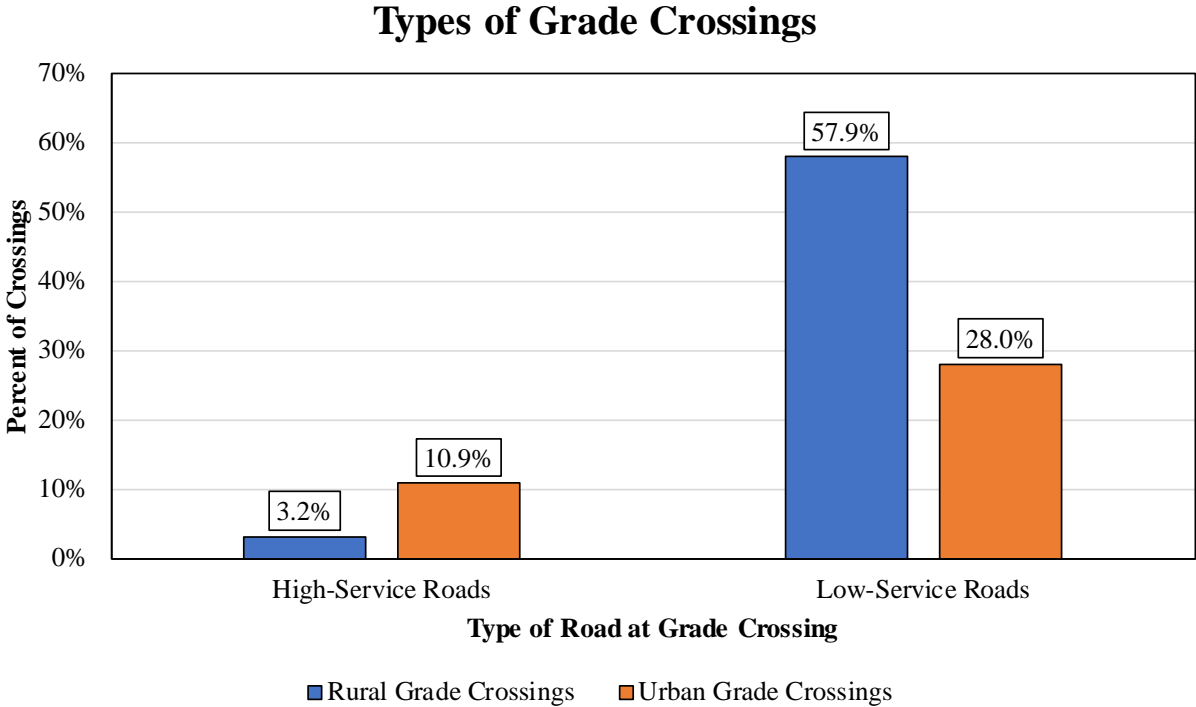

Figure 117. Distribution of Grade Crossings by Location [10]

### Types of Grade Crossings

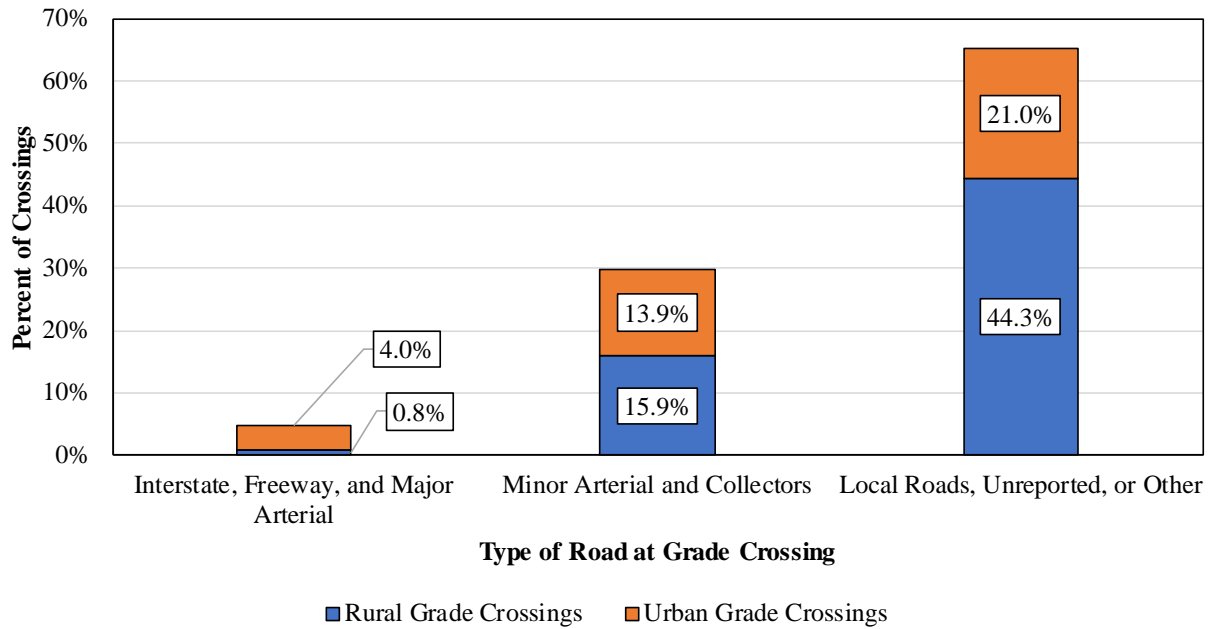

Figure 118. Distribution of Grade Crossings by Roadway Classification [10]

Railroad land grants through the early 1870s were as wide as 400 ft (122 m) along the length of the railroad, but new land grants easements in 1875 were reduced to 200 ft (61 m) with the General Railroad Right of Way Act [51]. Over time, sale, eminent domain, or inactivity has resulted in the reduction of many railroad rights of way, and rights of way may be unique to railroad companies or geographic locations (e.g., urban areas). Nonetheless, grade crossings are still considered part of railroad right-of-way.

### 5.3 Track Maintenance and Repair

Railroad lines require strict monitoring to ensure safe passage for trains. Uneven or misaligned railroad tracks can lead to disastrous results. A freight train derailment in London in February 2018 was attributed to significant rail twisting [52]. Track warping and bending was blamed for a commuter metro train derailment in Washington, D.C., in January 2018 [53]. A Los Angeles Times review of train derailments with crude oil identified fifty-three derailments of crude oil mostly related to track problems [54]. As railway companies extend train lengths and increase

freight traffic of commodities, goods, raw chemicals, and particularly hazardous materials, there is significant need to ensure track conditions are acceptable for safe passage of the trains and train cars to prevent ecological disasters as well as injuries and fatalities.

### 5.3.1 Track Construction

Typical railroad track construction requires multiple layers of compacted materials. Track construction, reinforcement, compaction, and soil and reinforcement materials are dependent on the service level of the track and the design [56]. Typically, tracks are built up using four distinctive layers or elements: subgrade (“formation”); ballast; sleepers (“railroad tie”), and rail. An example of track construction is shown in Uzarski’s *Introduction to Railroad Track Structural Design* [56].

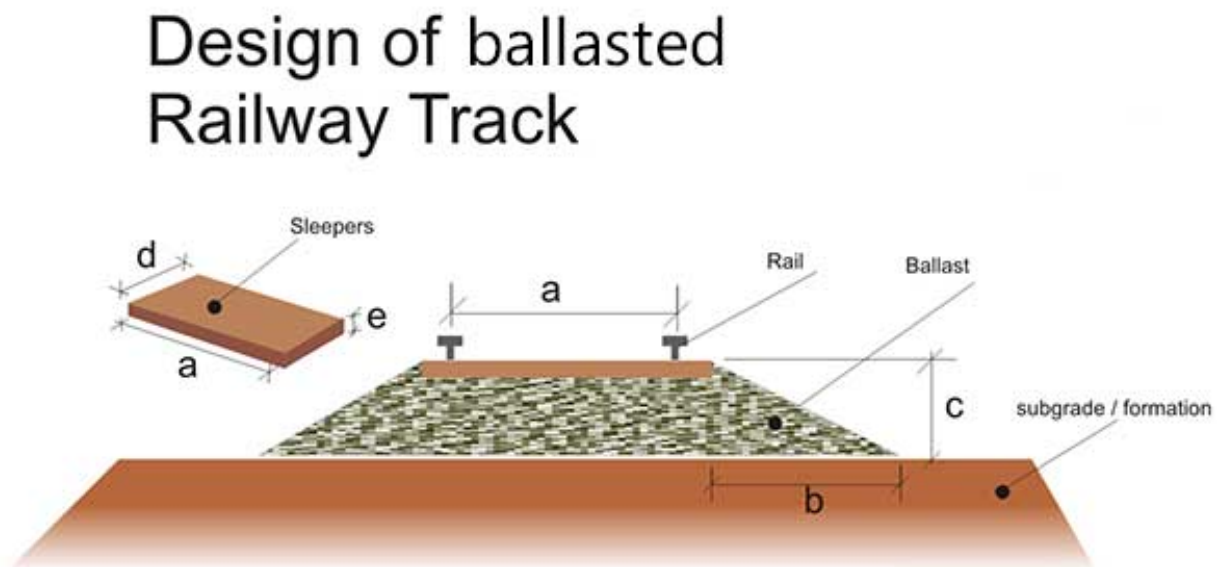

Figure 119. Example of Track Construction [57]

### 5.3.2 Track Maintenance

Informal interviews were conducted with employees of railway companies who conduct track maintenance. Interviews were primarily focused on the tasks required to perform track maintenance and did not address railroad policy, decision-making, regulation, or safety considerations.

Rail track maintenance is sustained through close inspection and construction. Routine inspection of tracks is performed using specially-fitted vehicles (typically pickup trucks) which are equipped to travel on railroad tracks, performing visual inspection of layout, track distortions, and crossing geometries. Additional closer inspections are scheduled and may utilize surveying equipment to detect variations in rail geometries. Companies determine the relative risk associated with those variations and the cost-effectiveness of various treatment methods. If track geometries are determined to warrant maintenance, costs associated with various maintenance activities are assessed and the most cost-effective treatment is typically utilized.

Anecdotally, most track maintenance is used to straighten tracks due to “bumps” or waves in the rails, mostly caused by settling of ballast materials beneath tracks. Repairing the ballast by removing tracks, reshaping subgrade and ballast, and reinstalling tracks is expensive and may require extensive construction, subgrade and ballast removal and replacement, and significant compaction. Often, the most cost-effective solution is to remove tracks within the maintenance region, install additional ballast at low points of the track, compact the new ballast material, and reinstall the tracks. If ballast and subgrade material is not removed, there is less need to reshape and recompact the railroad foundation supports, which greatly reduces construction and maintenance costs. However, raising low points in the track can result in an increase in overall track height. Some anecdotal reports suggest that the increase in track height can be as much as 4 in. (102 mm).

At grade crossings, due to railroad right of way, modifying a track height may require repaving the roads at grade crossings. Guidelines for paving grade crossings require that road surfaces be level with tracks through the crossings [e.g., 58]. If track elevations are increased and grade crossings are repaved, grade crossing geometries which were previously compliant with AASHTO/AREMA (2015) specifications for grade crossing slopes and heights may become non-



compliant, particularly when railroad right of way is constrained and adjacent to public right of way, such as a roadway running parallel to the railroad tracks. Unless the elevation of adjacent property is also raised, even small increases in railroad track heights can create grade crossing geometries which are non-conducive to long-wheelbase, low-ground clearance vehicles and trailers.

Moreover, the large number of rail grade crossings are maintained by a handful of railroad companies. Altering track geometries at each of the grade crossings could require trillions of dollars in total cost and extensive delays in freight traffic, resulting in significant economic losses for railroad companies. Also, many grade crossings were first constructed well before modern guidelines were prepared to address low-ground clearance vehicles. If half of the nationwide grade crossings are not consistent with AASHTO/AREMA (2015) guidelines, and if one grade crossing geometry were reconstructed to be compliant with AASHTO/AREMA (2015) guidelines every day of the year, construction would last more than 200 consecutive years.

#### **5.4 Recommendations**

Improving grade crossing geometries will require time, money, and careful planning to not become an economic or convenience burden on railroad companies and customers dependent on freight and passenger transportation. Researchers therefore utilized this study to prioritize which grade crossings should be repaired or modified first, based on the likelihood of low-height vehicles becoming high-centered on tracks resulting in continued significant losses to railroad and trucking companies as well as negative nationwide economic impacts. To evaluate prioritization of grade crossing construction, researchers prepared simulations of realistic truck-and-trailer and bus combinations traversing grade crossings to determine potential for undercarriage scraping (undercarriage within 1 in. (25 mm) of edge of track) and contact (interference between undercarriage and crossing geometry) at varying elevations of track geometries. Critical

configurations were identified for various vehicle-trailer geometries. These results are provided in Chapters 7 through 9. Per the *Railway-Highway Grade Crossing Handbook* [10], reasons for non-compliance with federal recommendations should be documented and held in project files by both federal and railroad agencies. If this documentation is not up to date, researchers recommend that surveys be conducted to begin development of this trackable database.

In addition, it is recommended that construction timing be relayed to state DOTs for monitoring, and that DOTs and railroads coordinate surveys of road and crossing geometries near grade crossings after maintenance repairs are completed to ensure proper heights of roads leading up to, at, and following grade crossings. Existing rail grade crossings with crash histories should be prioritized for repair work with coordination between municipalities, local authorities, railroad companies, and state DOTs. When necessary, legislation or executive directives should be provided to reduce barriers to cooperation between state and local authorities and railroad companies, possibly by minimizing possible litigation and streamlining approval and construction processes.

## 6 MODELING AND SIMULATIONS WITH LS-DYNA

Simulations with LS-DYNA, a non-linear, 3D finite element analysis software, were desired to evaluate suspension properties of a tractor-trailer truck in more detail [59]. Therefore, it was essential to utilize a realistic truck model which can capture the responses of the vehicle during an event. The tractor-trailer model selected for the project was created from a model originally developed by a research team of Battelle, Oak Ridge National Laboratory (ORNL) and the University of Tennessee at Knoxville (UTK) [60-62]. The tractor-trailer model was developed based on a 1991 GMC tractor with a 1988 Pines semitrailer to meet the requirements of the roadside safety research, as shown in Figure 120 [63]. The model was reasonably validated with several full-scale crash tests results to obtain the accuracy of the deformations of tractor and trailer, the overall behavior of the tractor-trailer, and general tractor-trailer interaction given the model computational requirements. Some modifications to the tractor-trailer model were implemented by Chuck Plaxico of Roadsafe, LLC and John Reid of MwRSF to refine the vehicle model and ensure the reasonable behaviors of the vehicle while reducing computational requirements. Based on the comparisons with full-scale test results, the refined tractor-trailer model was valid to provide useful results in the design and evaluation of the vehicle-barrier interaction under impact loads.

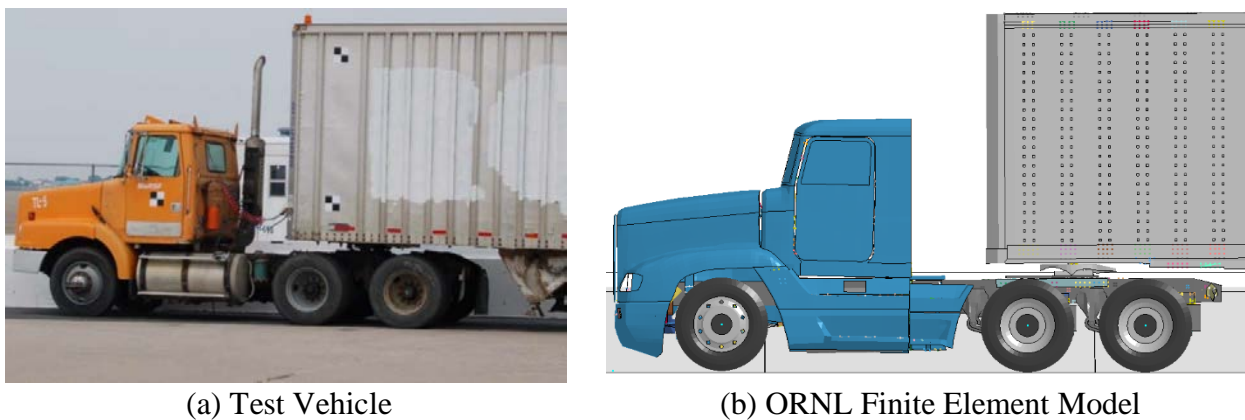

Figure 120. ORNL Test Vehicle Model and ORNL Finite Element Model [63]

The tractor-trailer model was utilized to perform the simulations of a tractor-trailer vehicle traversing a speed table used for test nos. UTCRS-1 through UTCRS-4. Before the speed table simulations, the tractor-trailer model was checked via running the model at a speed of 5 mph (8.05 km/h) on a flat plane for 8 seconds. Some errors which may affect the behaviors of the tractor-trailer model during the simulations were discovered in the model. In this model, the contacts between several beam elements and shell elements, as shown in Figure 121, were simulated using CONTACT\_AUTOMATIC\_SINGLE\_SURFACE, which did not work well. Some suspension components disconnected from the main tractor frame. Therefore, the contacts between beam elements and shell elements were modified with a new contact to fix the error using CONTACT\_AUTOMATIC\_GENERAL. The gravity load curve was also updated to extend the time at which the gravity load was applied during the simulation. Graphical comparisons of the results from both the model modified by Plaxico and Reid and the updated model for the UTCRS project, as shown in Figures 122 and 123, demonstrated that the behavior of the tractor-trailer model was improved for the further evaluation simulations.

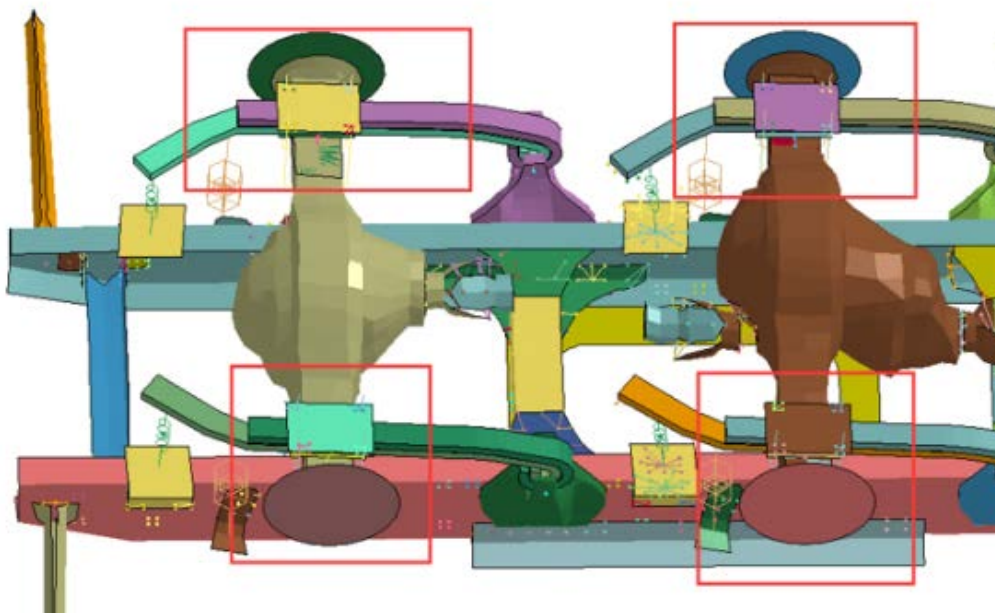

Figure 121. Suspension Components in the Tractor-Trailer Model

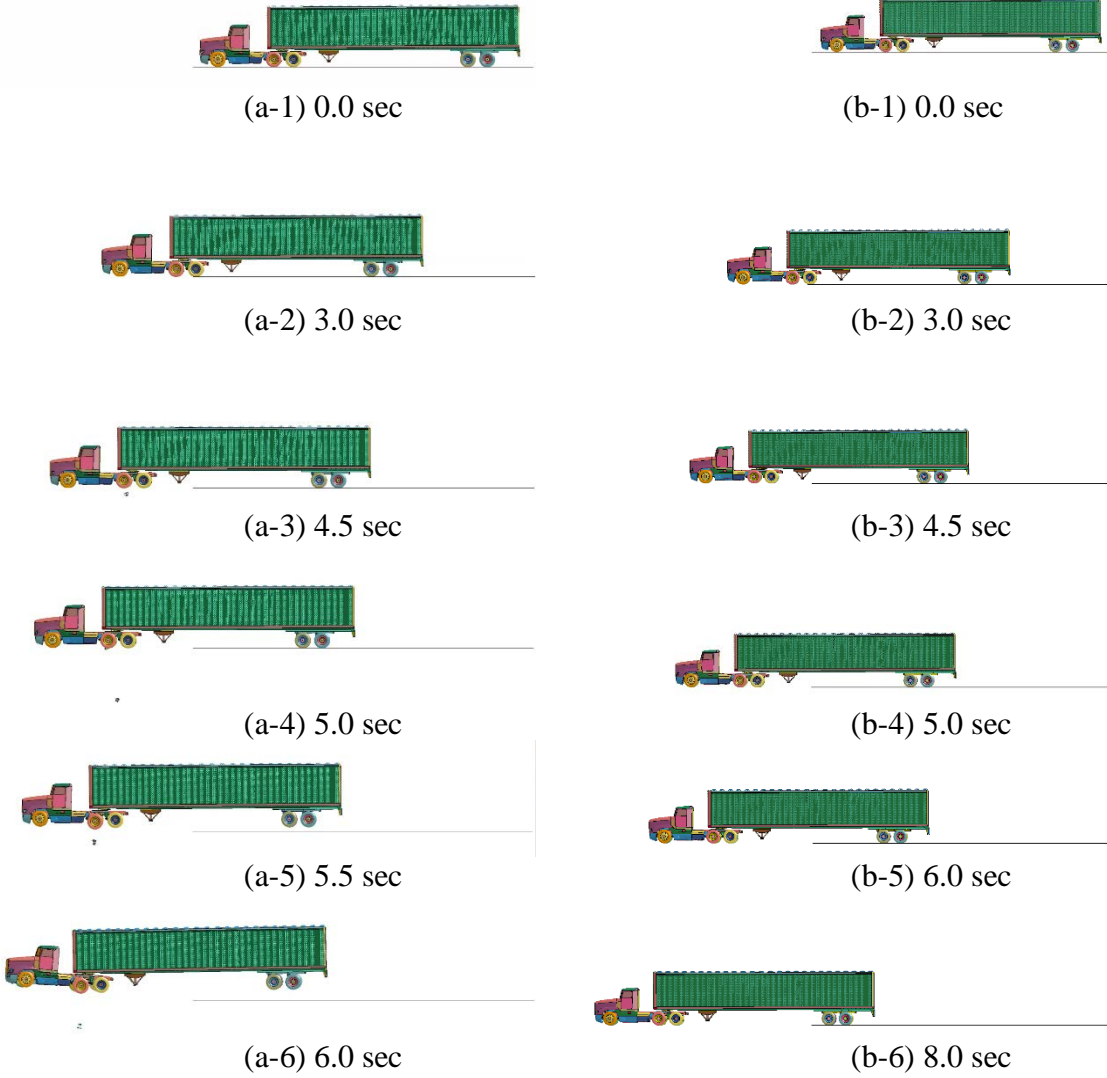

Figure 122. Side Sequential View, (a) Model Developed by Plaxico and Reid and (b) Updated Model



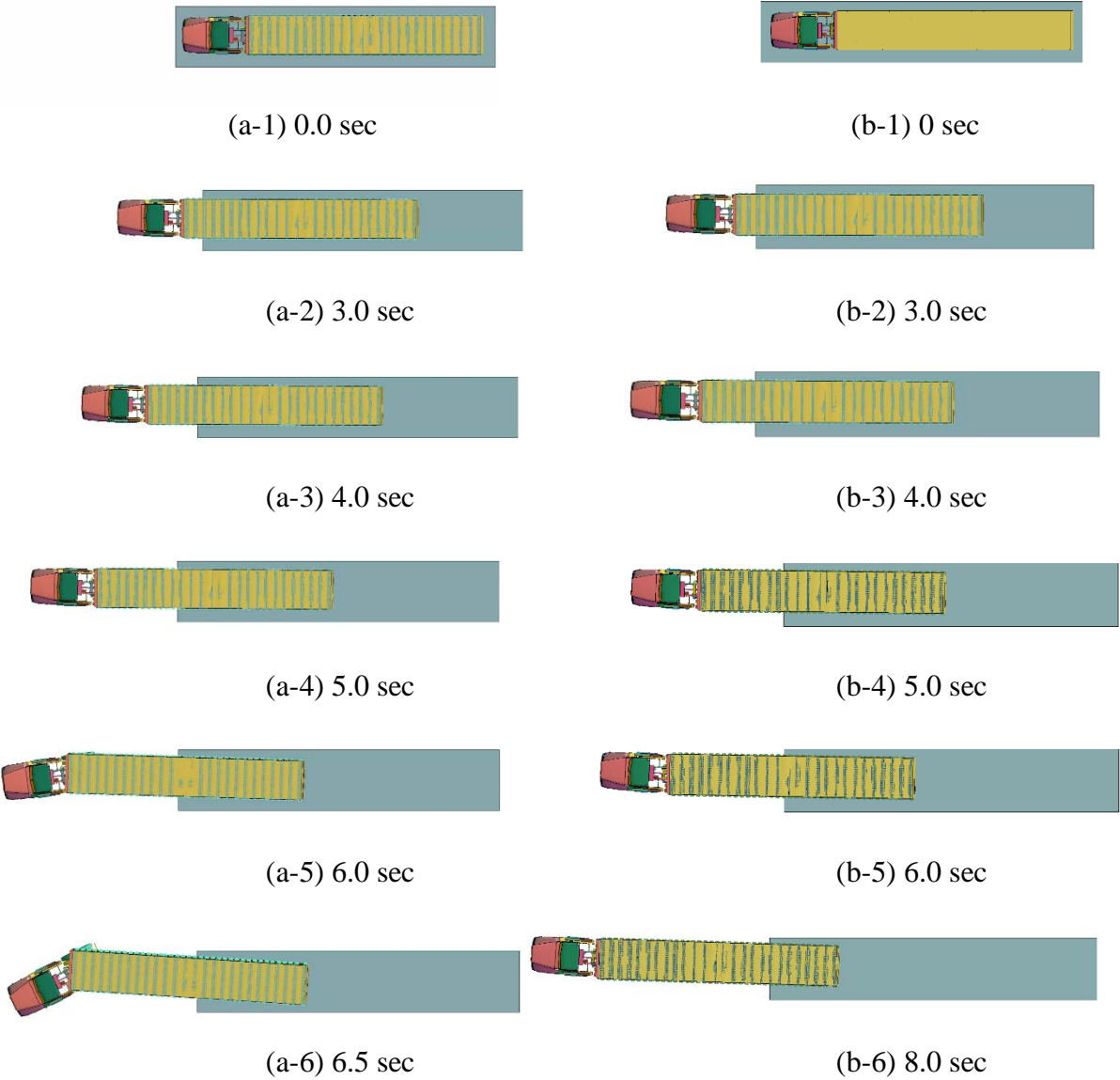

Figure 123. Overhead Sequential View, (a) Model Developed by Plaxico and Reid and (b) Updated Model

The updated tractor-trailer model was further evaluated based on the simulation models of the tractor-trailer vehicle traversing a speed table, which corresponded to the system in full-scale speed table tests. In the tests, a tractor trailer with varied velocities drove over a speed table to gather vehicle motion data. The computer simulation results were compared with the physical test results obtained from the speed table tests to evaluate the suspension properties of the model. The

finite element modeling of the tractor-trailer traversing a speed table was based on the UTCRS drive-over speed table tests, test nos. UTCRS-2 and UTCRS-3. The speed table is shown in Figure 39 and the speed table dimensions are shown in Figure 40. The tractor-trailer traversed the speed table at an average speed of 7.7 mph (12 km/h) and 11.7 mph (18.8 km/h) in test nos. UTCRS-2 and UTCRS-3, respectively. In order to investigate the efficiency of finite element modeling, two numerical models of the speed table corresponding to the UTCRS test were developed: one made out of RIGIDWALL\_PLANAR\_FINITE, and one that is meshed with the geometry using eight-node constant stress solid brick elements, as shown in Figure 124. The solid speed table was modeled using MAT\_RIGID material model, and the contact between the tractor-trailer model and the solid speed table was defined as a segment-based contact using CONTACT\_AUTOMATIC\_SINGLE\_SURFACE.

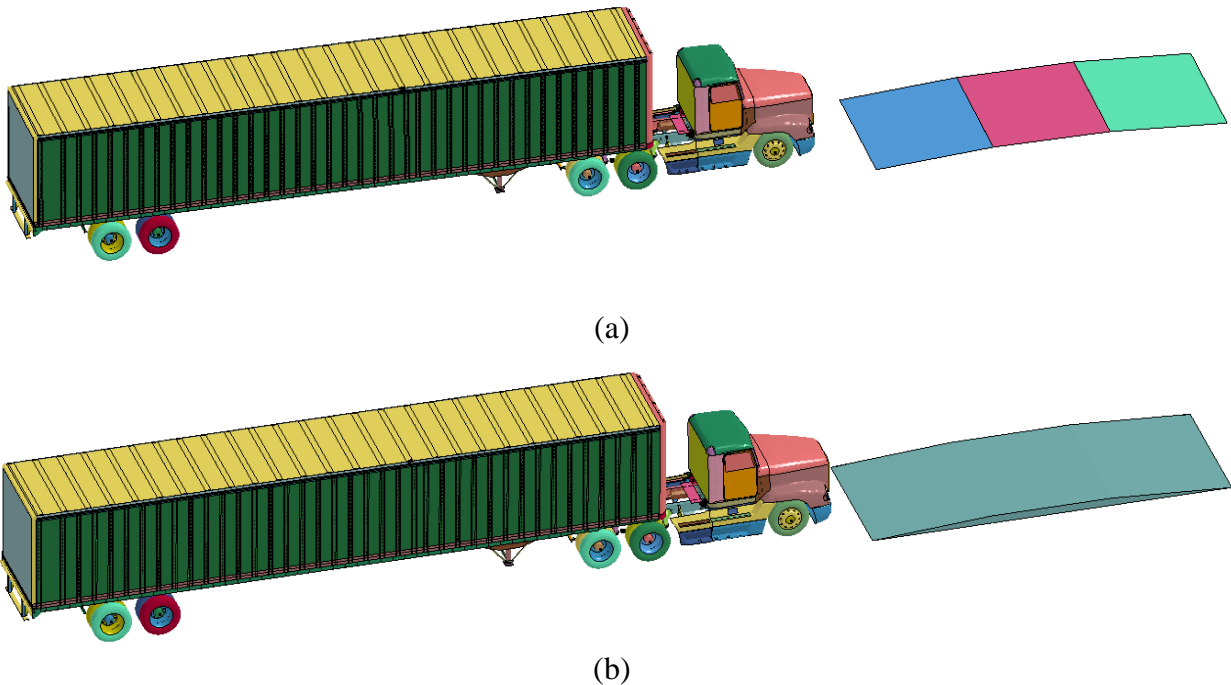

Figure 124. Speed Table Model, (a) Rigidwall Planar Finite and (b) Brick Solid Element

Graphical comparisons of the results from both of the speed table models and test no. UTCRS-2, as shown in Figures 125 and 126, showed that the behaviors of the vehicle in the full-scale test matched reasonably with the simulation models, and both rigidwall finite plane and solid element speed table models were feasible to predict the behaviors of the tractor-trailer traversing a speed table. Graphical comparison of results between the rigidwall finite plane model and the solid element model, as shown in Figure 127, demonstrated that the response of the tractor-trailer in the rigidwall finite plane model was very similar with the solid element model, while the run time for the rigidwall finite plane model was much less than the solid element model.

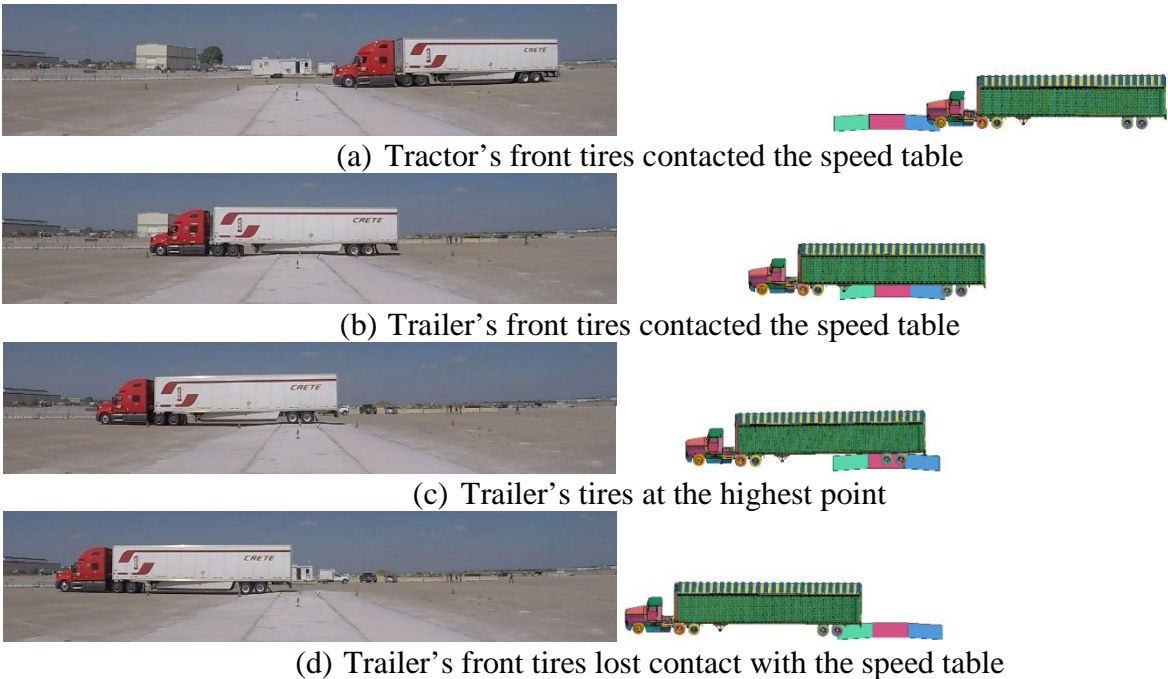

Figure 125. Side Sequential View, Rigidwall Speed Table Model, Test No. UTCRS-2

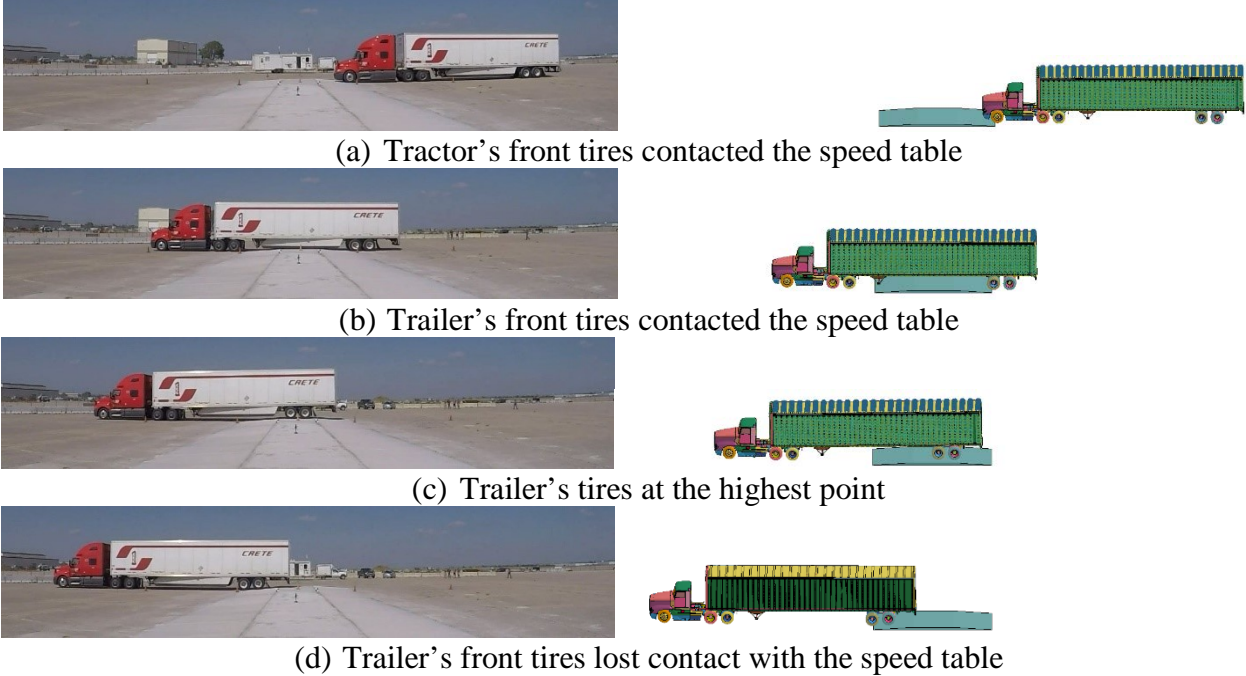

Figure 126. Side Sequential View, Solid Speed Table Model, Test No. UTCRS-2

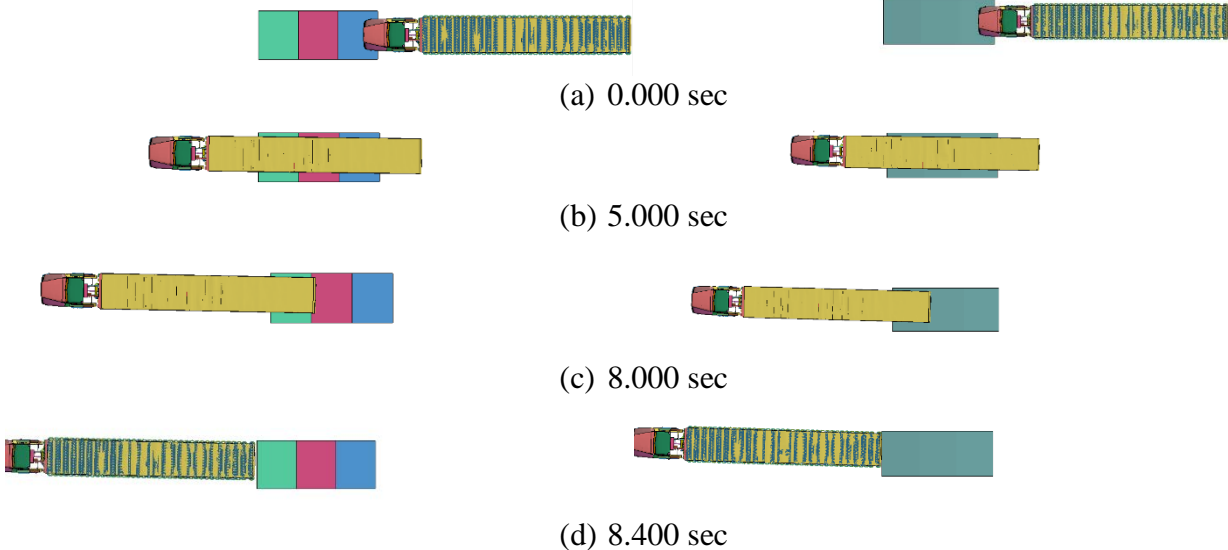

Figure 127. Overhead Sequential View, Rigidwall and Solid Speed Table Models, Test No. UTCRS-2

Graphical comparison of the results from both the numerical models and test no. UTCRS-3, as shown in Figures 128 and 129, showed that both the rigidwall finite plane model and the solid element model agreed well with full-scale test no. UTCRS-3. Both models are useful to analyze

the responses of the tractor-trailer driving over a speed table. Comparison of the results between the rigidwall finite plane model and the solid model, as shown in Figure 130, demonstrated that the tractor-trailer obtained in the rigidwall finite plane model showed the same behaviors with the solid element model, and the rigidwall finite plane model was more efficient for the project due to less run time.

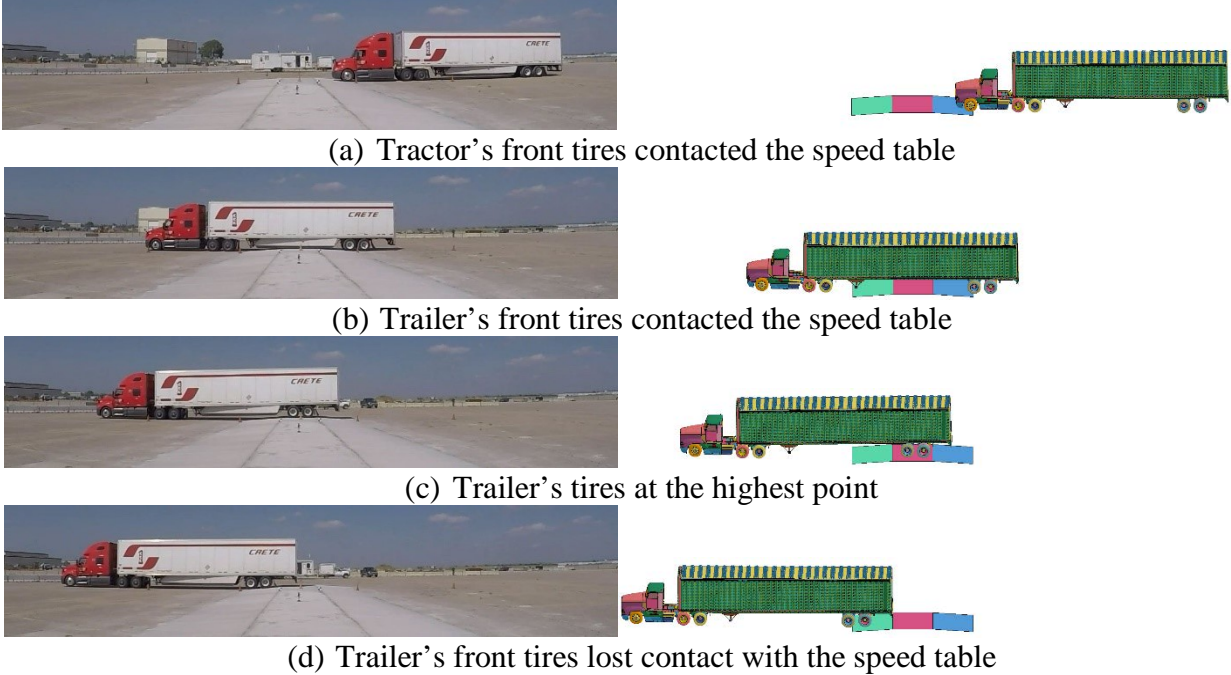

Figure 128. Side Sequential View, Rigidwall Speed Table Model, Test No. UTCRS-3



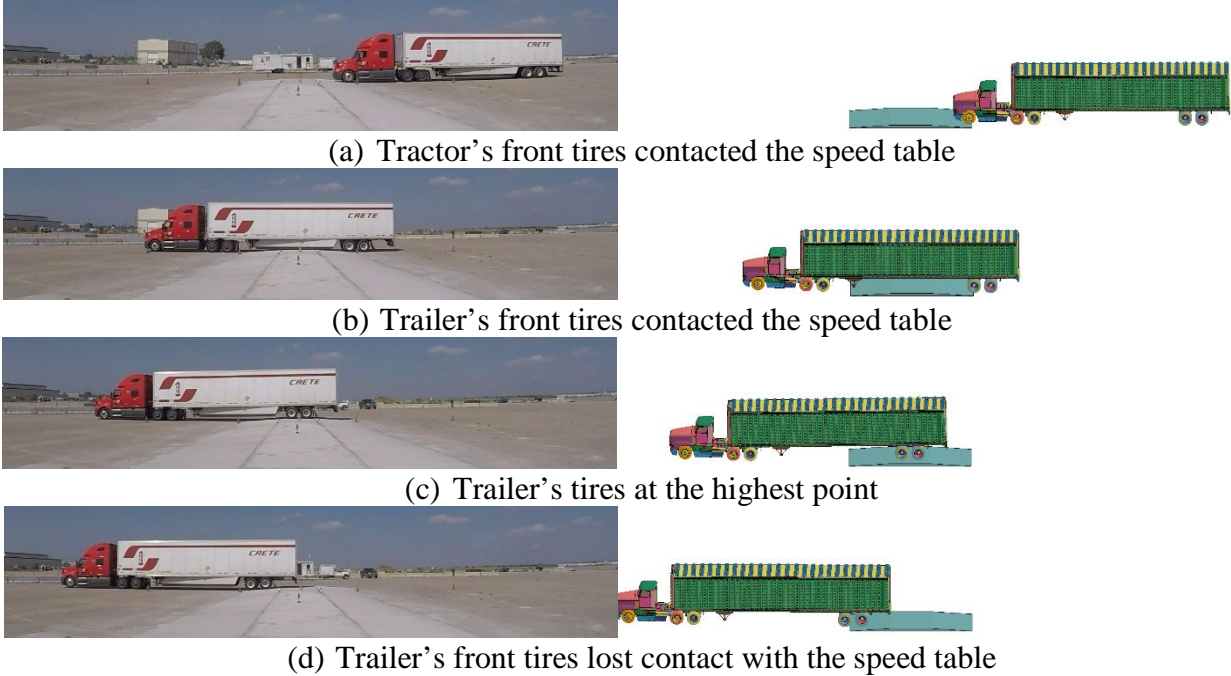

Figure 129. Side Sequential View, Solid Speed Table Model, Test No. UTCRS-3

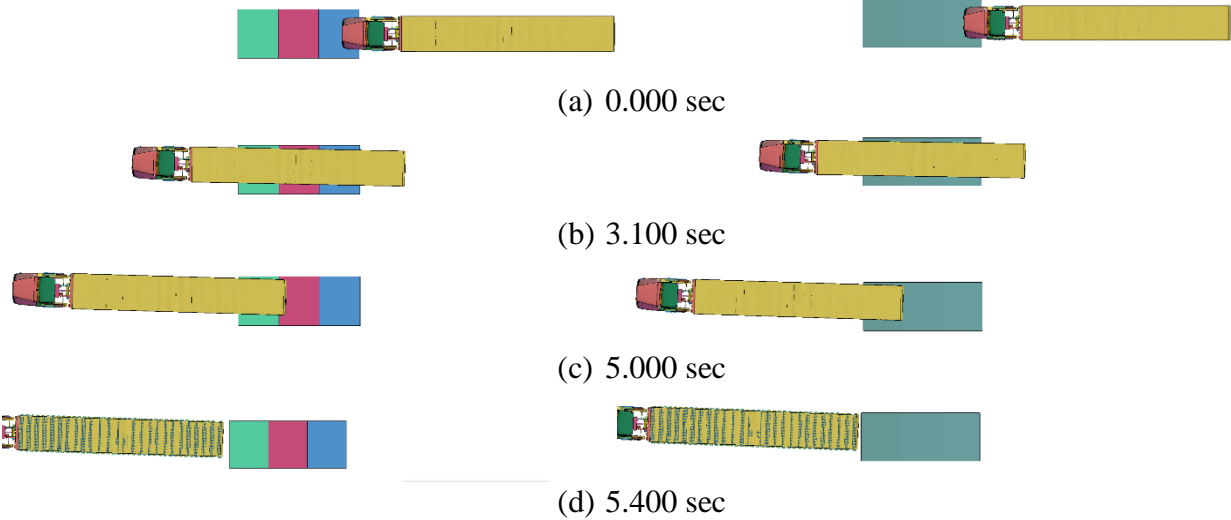

Figure 130. Overhead Sequential View, Rigidwall and Solid Speed Table Models, Test No. UTCRS-3

Several analysis targets were selected from the trailer and the tractor to measure the vertical displacements for evaluation of the tractor-trailer model, as shown in Figure 131. Four targets, designated Trailer 1 through Trailer 4, were selected above the centers of the rear wheels of the

tractor and the front and rear wheels of the trailer. Two fixed targets, designated Anchor 1 and 2, were defined on the speed table, and the heights of the anchors were about 2 in. (51 mm) from the ground to the center of the target. The relative displacements between Anchor 2 and the trailer targets were utilized to investigate the responses of the tractor-trailer traversing the speed table. The analysis targets above the centers of these wheels were selected from the tractor-trailer numerical model to evaluate the model feasibility. A comparison of the relative vertical displacement between the tests and the models is shown in Figures 132 and 133. The displacements of all targets received from the rigidwall finite plane model were similar to the solid element model, and the difference in displacement between the two numerical models was reasonably negligible. Owing to the relatively shorter model run time, the rigidwall finite plane model was more efficient for investigating the responses of the tractor-trailer driving over a speed table. The comparison of the relative displacement between the tests and the numerical models demonstrated that the differences of the relative displacement were observed in both tests, which may be partially due to the behavior of the suspension parts in the tractor-trailer model. The springs and dampers of the suspension parts do not have adequate stiffness to support the vehicle, which affects the tractor-trailer's behavior. Hence, the stiffness of the springs and dampers was increased in the model to analyze the responses of the tractor-trailer traversing the speed table and refine the tractor-trailer model.

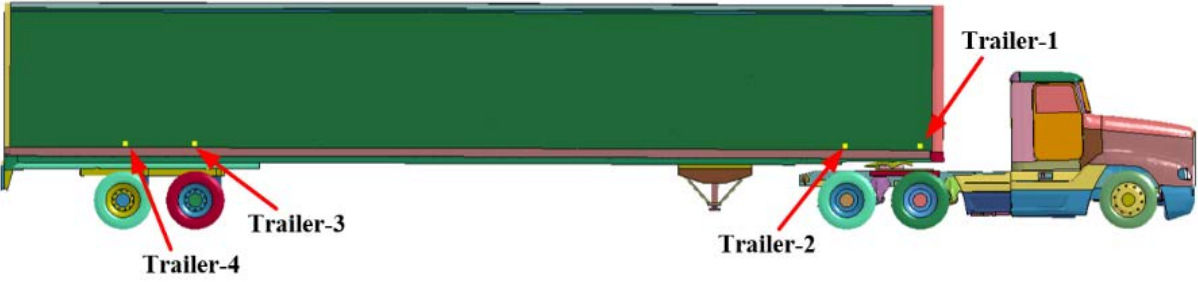

Figure 131. Analysis Targets, Test Nos. UTCRS-2 and UTCRS-3 and Model

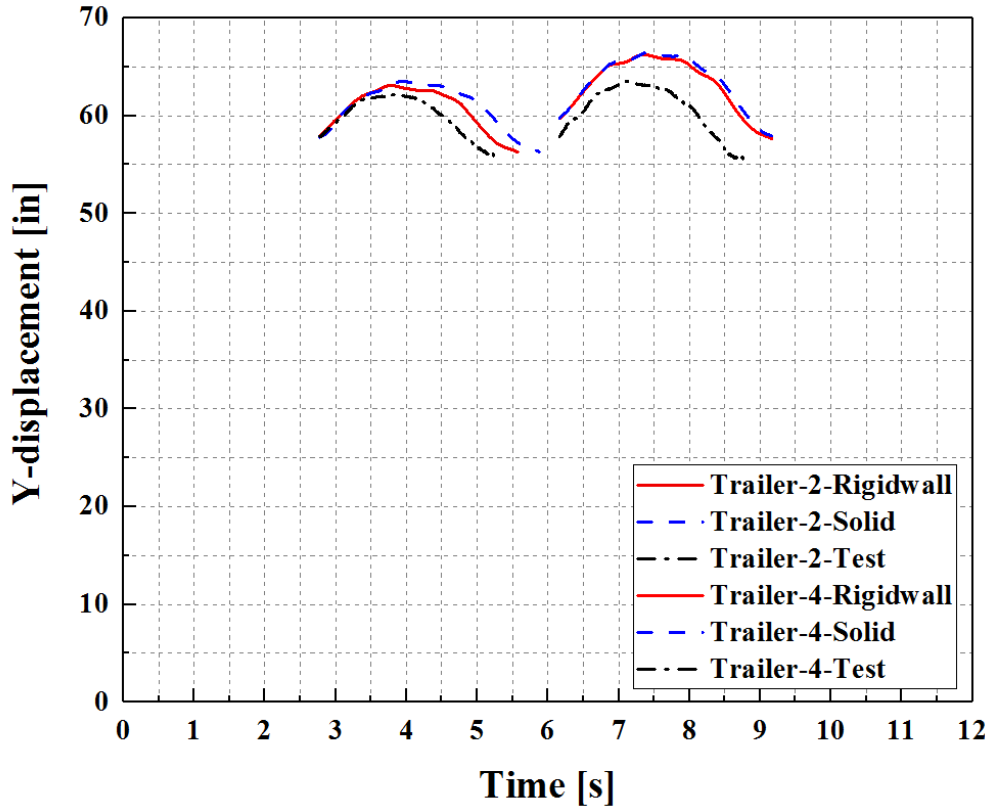
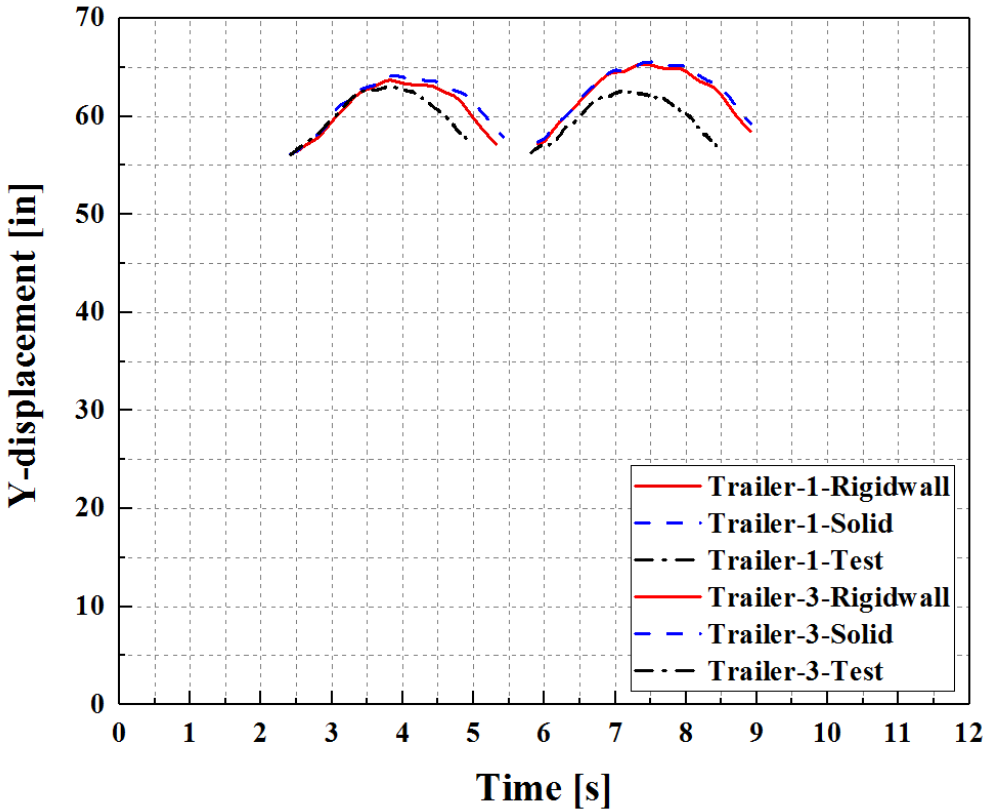

Figure 132. Change in Y-Displacements, Simulation of Test No. UTCRS-2

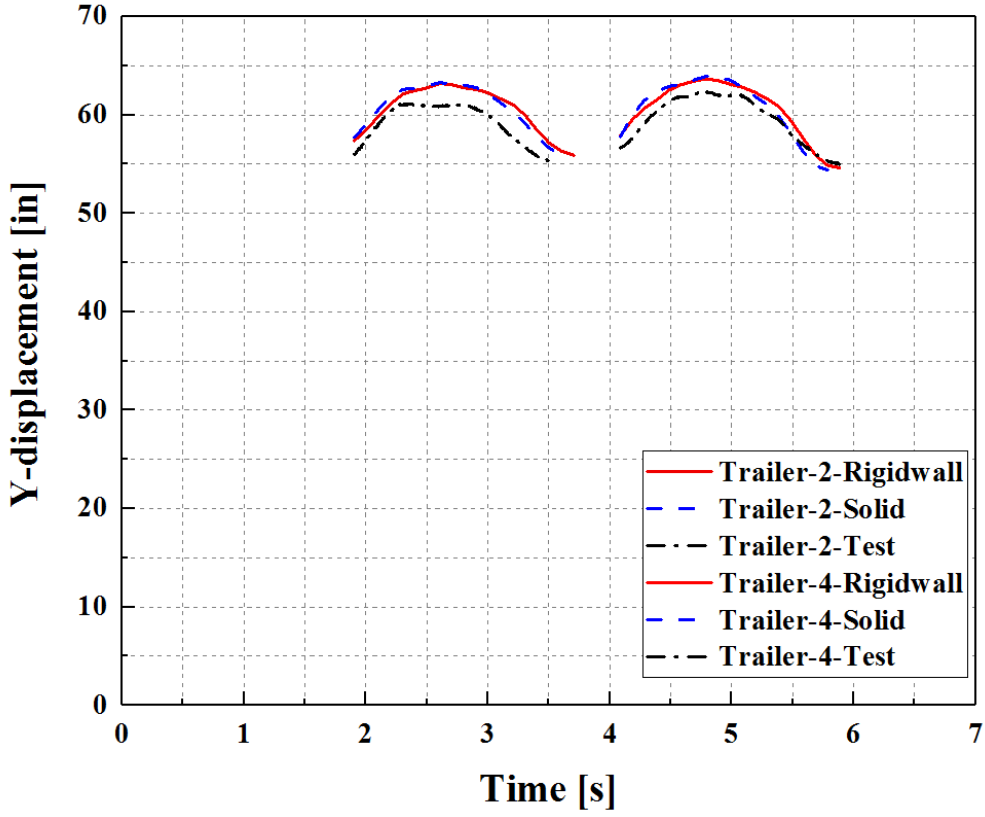
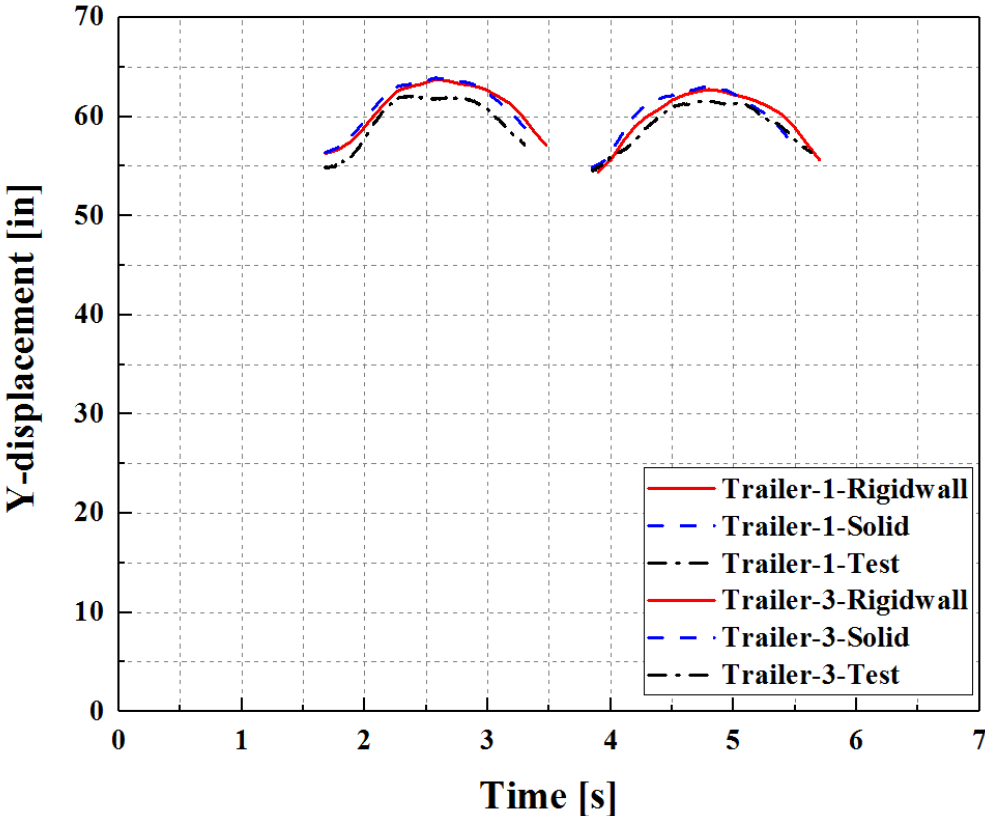

Figure 133. Change in Y-Displacements, Simulation of Test No. UTCRS-3



Based on the comparison between the rigidwall finite plane model and the solid element model, the rigidwall finite plane model was utilized to perform the simulations updating the stiffness of the springs and dampers due to its efficiency and feasibility in modeling. In the tractor-trailer model, the dampers were simulated using MAT\_SPRING\_MAXWELL, which determines the stiffness of the dampers based on the short-time stiffness (K0) and the long-time stiffness (KI). The default primary parameters for the damper were  $K0=0.055$  kN/mm and  $KI=1 \times 10^{-7}$  kN/mm. The springs were modeled with a spring material model using MAT\_SPRING\_NONLINEAR\_ELASTIC, which defines the material parameters with an arbitrary force versus displacement curve, as shown in Figure 134. The spring and damper parameters were varied to better match the vertical displacement of the trailer in test nos. UTCRS-2 and UTCRS-3. However, a better match was not achieved and thus, those results are not reported herein.

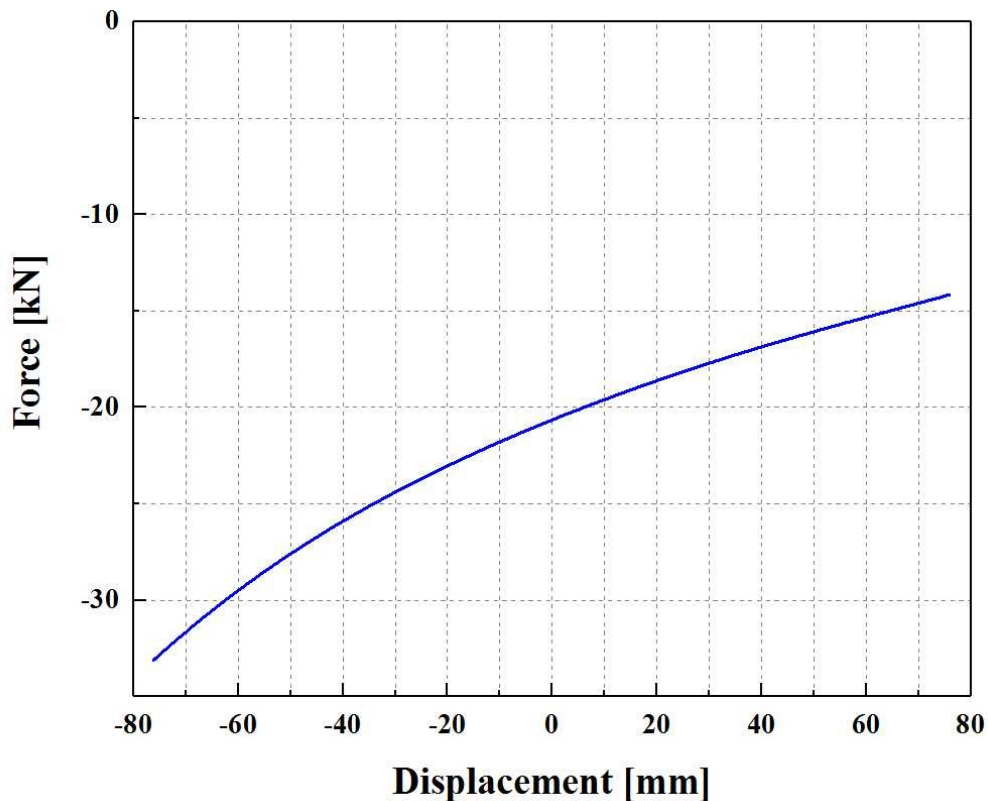

Figure 134. Force vs. Displacement Curve for Springs

## **7 TRUCKSIM PARAMETERS AND METHODS**

### **7.1 Introduction**

Static truck-and-trailer geometrical contributions were evaluated using AutoCAD and a static (non-compressible suspension and fixed geometry) configuration of a truck and trailer crossing various grade crossings. The static analyses were used to estimate whether track geometries were likely to create interference problems for truck-trailer combinations using TruckSim.

To accurately evaluate crossing guidelines, the program TruckSim was utilized to model long-wheelbase vehicles and a simulation matrix of crossing profiles. The program was used to simulate a tractor with a lowboy trailer as well as a bus, and both vehicle types were evaluated by traversing simulated grade crossings. Each simulation was evaluated to determine the likelihood of a low-clearance trailer becoming high-centered on the tracks.

Prior to executing simulations of tractor-trailers traversing speed table shapes, simulations of test nos. UTCRS-1 through UTCRS-4 were performed to calibrate the models and confirm the accuracy of the output compared to physical test data.

### **7.2 Static Analysis**

Initially, a static analysis using 2D AutoCAD software was performed prior to the TruckSim simulations. The AREMA (1990), ICC, and SPR crossing and elevated crossing guidelines were evaluated with the tractor-lowboy vehicle model with wheelbases ranging between 26 ft to 42 ft (7.9 m to 12.8 m), in 2-ft (0.6-m) increments.

The procedure for the static analysis began with modeling the crossing profile in AutoCAD software. Next, the vehicle model was placed on the crossing with the wheels aligned level on the crossing approach and departure slopes. The height between the bottom of the vehicle and the top

of the rails was recorded. This value corresponded to the minimum ground clearance needed for the vehicle model to safely traverse the crossing.

The results of the static analysis for the AREMA (1990), ICC, and SPR guidelines are shown in Sections 8.3.1, 8.4.1, and 8.5.1, respectively. The tractor-lowboy utilized in TruckSim simulations had a ground clearance of 6.5 in. (165 mm), so crossings requiring a smaller ground clearance are highlighted green. Crossings which require ground clearances between 5.5 in. and 6.49 in. (140 mm and 165 mm) are highlighted yellow, and crossings which require ground clearances greater than 6.5 in. (165 mm) are highlighted red.

### **7.3 TruckSim Program**

The simulation program TruckSim was utilized to model long-wheelbase vehicles traversing various crossing configurations to determine geometries which would be likely to experience interference between the crossing and trailer frame. TruckSim is produced by the Mechanical Simulation Corporation. The parameters and methods used for this research study are detailed in the following sections.

### **7.4 Vehicle Models**

Two vehicle models were evaluated using the TruckSim program: a tractor with a lowboy trailer and a bus. Buses and RVs have very similar exterior dimensions, such as ground clearance and wheelbase; therefore, the bus model was adequate to evaluate both types of vehicles.

#### **7.4.1 Tractor with a Lowboy Trailer**

The tractor-lowboy vehicle model included a three-axle daycab tractor with a fifth wheel hitch. The trailer model was a two-axle lowboy with a ground clearance of 6.5 in. (165 mm), which was not altered for any of the simulations. The tractor with a lowboy trailer vehicle model is shown in Figure 135.

The vehicle wheelbase was modified to reflect dimensions for the tractor-lowboy vehicle model recorded during real-world survey and inspection, and which was described in AASHTO's *A Policy on Geometric Design of Highways and Streets* [8]. Wheelbase dimensions from various trailer manufacturers, including Eager Beaver Trailers, Fontaine, Globe Trailers, Interstate Trailers, Kalyn Siebert, Load King, Pitts Trailers, Talbert, Witzco Challenger Trailers, and XL Specialized Trailers, were compiled to determine wheelbase dimensions to simulate. Results of that investigation were used to develop a matrix of vehicle and trailer dimension simulations, and the dimensions utilized in simulations are shown in Table 10. Wheelbases ranging from 26 ft (7.9 m) to 61 ft – 8 in. (18.8 m) were simulated for the tractor-lowboy vehicle model.



Figure 135. TruckSim Tractor with a Lowboy Trailer Model

Table 10. Tractor-Lowboy Vehicle Models Simulated in TruckSim

Wheelbase ft-in. (m)	Ground Clearance in. (mm)
26-0 (7.9)	6.5 (165)
28-0 (8.5)	
30-0 (9.1)	
32-0 (9.8)	
34-0 (10.4)	
36-0 (11.0)	
38-0 (11.6)	
40-0 (12.2)	
42-0 (12.8)	
44-0 (13.4)	
46-0 (14.0)	
48-0 (14.6)	
50-0 (15.2)	
53-8 (16.4)	
56-2 (17.1)	
61-1 (18.6)	
61-8 (18.8)	

**7.4.2 Bus**

The bus vehicle model was a two-axle tour bus loaded with passengers and had a ground clearance of 12.5 in. (318 mm). No test data was available to calibrate or evaluate the bus model; thus, default inertial, power, steering, and suspension properties of the bus model were not altered for any of the simulations. The bus vehicle model is shown in Figure 136.





Figure 136. TruckSim Bus Model

Wheelbase dimensions were obtained from various bus and RV manufacturers, including American Coach, Champion, Coachmen, ENC, Federal Coach, Fleetwood, Forest River, Glaval, Holiday Rambler, MCI, Monaco, New Flyer, Newmar, Nova Bus, Prevost, Sentra, Thor Motor Coach, Tiffin, and Winnebago. The dimensions were compiled into a list and several values were used in the simulations. In addition, wheelbase and ground clearance dimensions were collected for forty-three RVs at Leach Camper Sales, a motorhome dealership located in Lincoln, Nebraska with permission from the owners. The simulated wheelbases for the bus vehicle model are listed in Table 11. Wheelbases ranging from 13 ft – 2 in. (4.0 m) to 27 ft – 10.5 in. (8.5 m) were evaluated for the bus vehicle model.

Table 11. Bus Vehicle Models Simulated in TruckSim

Wheelbase ft-in. (m)	Ground Clearance in. (mm)
13-2 (4.0)	12.5 (318)
17-4 (5.3)	
18-4 (5.6)	
21-0 (6.4)	
23-0 (7.0)	
24-1 (7.3)	
25-5 (7.7)	
26-6 (8.1)	
27-10.5 (8.5)	

### 7.5 Vehicle Speed

All simulations for the tractor-lowboy and the bus vehicle models traversing the AASHTO/AREMA (2015), AREMA (1990), ICC, and SPR crossings were performed at a speed of 5 mph (8.05 km/h). The simulations of test nos. UTCRS-1 through UTCRS-4 were performed at the same speeds as the speed table tests: 8.5 mph (13.7 km/h) for test no. UTCRS-1, 7.7 mph (12.4 km/h) for test no. UTCRS-2, 11.7 mph (18.8 km/h) for test no. UTCRS-3, and 12.8 (20.8 km/h) for test no. UTCRS-4. Results of this analysis are shown in Section 8.1.

### 7.6 Crossing Configurations

#### 7.6.1 Railroad Grade Crossing Guidelines

Four highway-rail grade crossing guidelines, from AASHTO/AREMA (2015) [8, 3], AREMA (1990) [12], ICC [11], and SPR [11], were modeled and simulated with TruckSim. The crossing profiles for each guideline are shown in Figure 137.

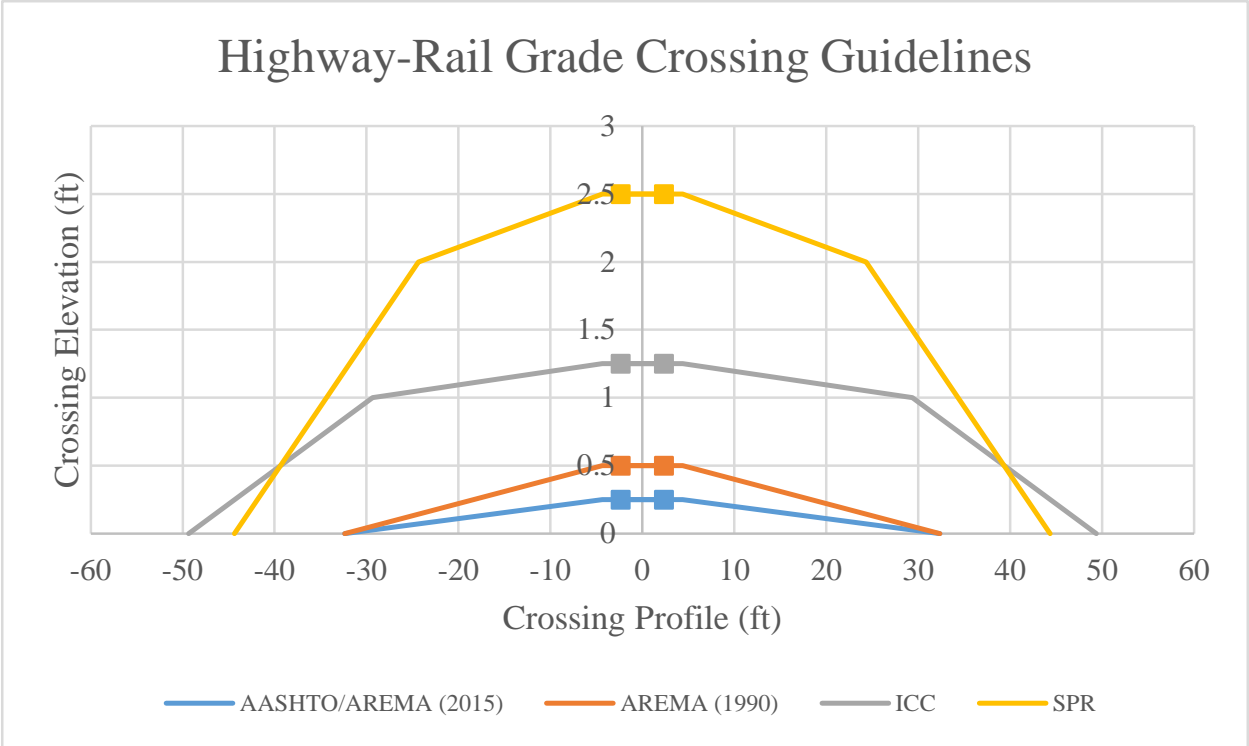

Figure 137. Crossing Profile Guideline Comparison

For each guideline, additional simulations were performed with modified track geometries, obtained by increasing the height of the tracks in 1-in. (25-mm) increments to a maximum height of 12 in. (305 mm) above the nominal guidelines, without adjusting the width of the footprint of the tracks. Adjacent to the tracks, 2 ft (0.6 m) of flat surface was modeled on either side of the tracks, and all track configurations were assumed to be symmetrical. The modified track profiles obtained by increasing track height in 1-in. (25-mm) increments for the AASHTO/AREMA (2015) guidelines are shown in Figure 138, for the AREMA (1990) guidelines in Figure 139, for the ICC guidelines in Figure 140, and for the SPR guidelines in Figure 141.

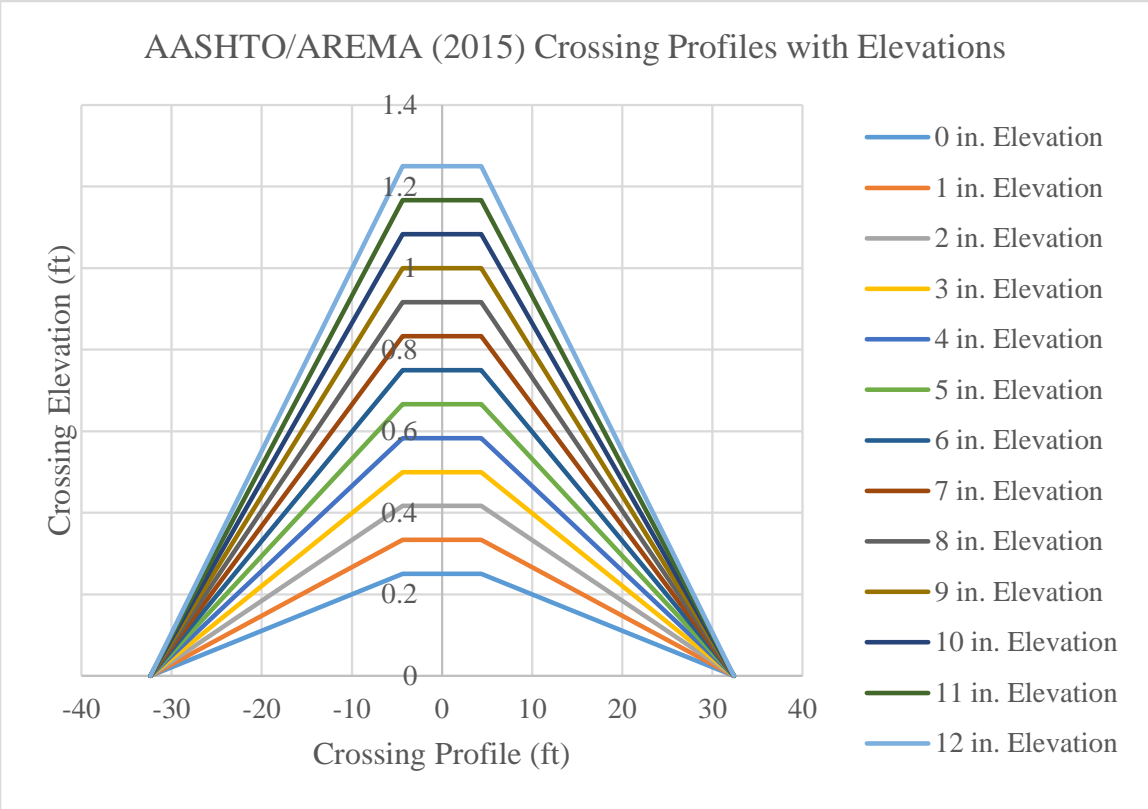

Figure 138. AASHTO/AREMA (2015) Crossing Profiles Simulated with TruckSim

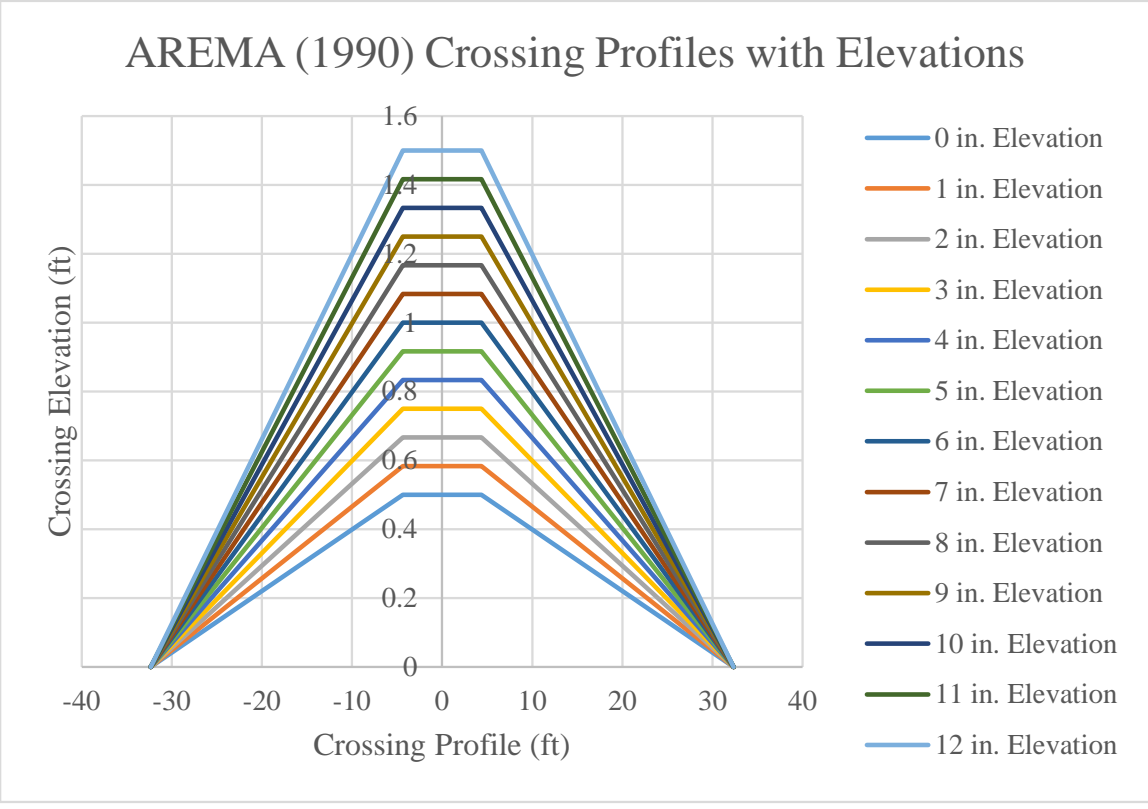

Figure 139. AREMA (1990) Crossing Profiles Simulated with TruckSim

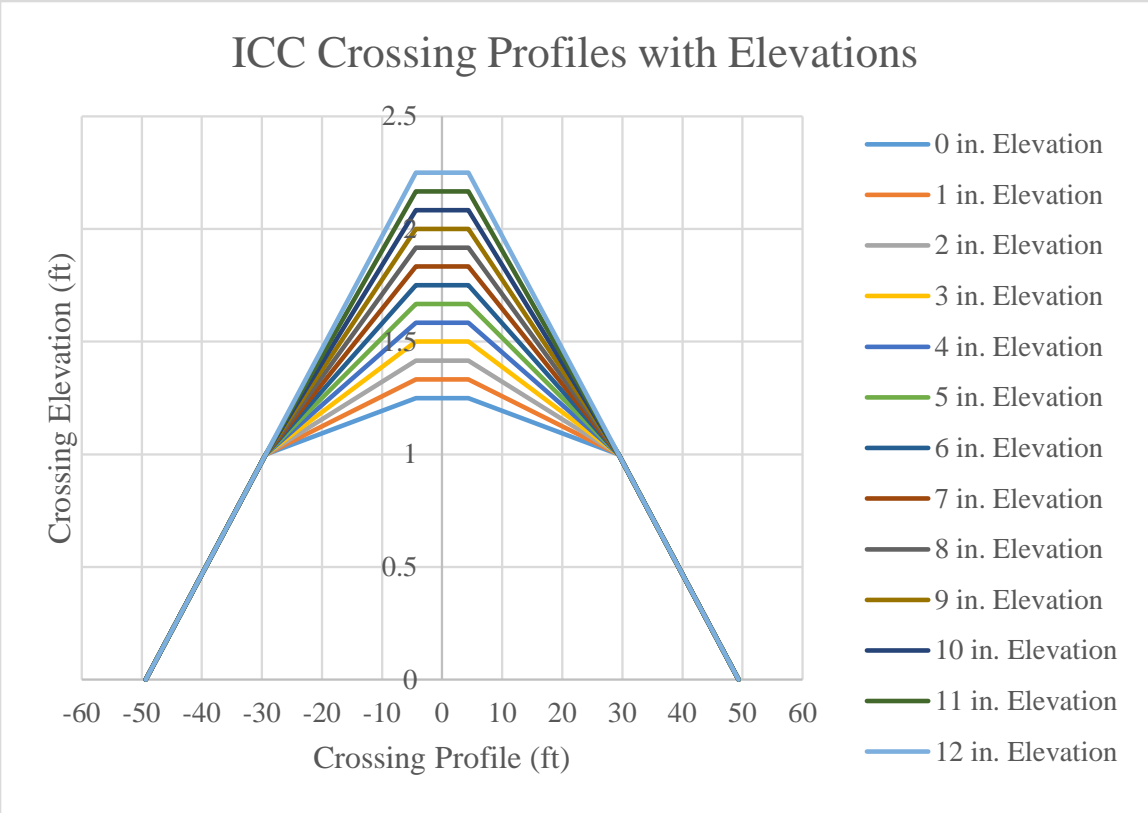

Figure 140. ICC Crossing Profiles Simulated with TruckSim

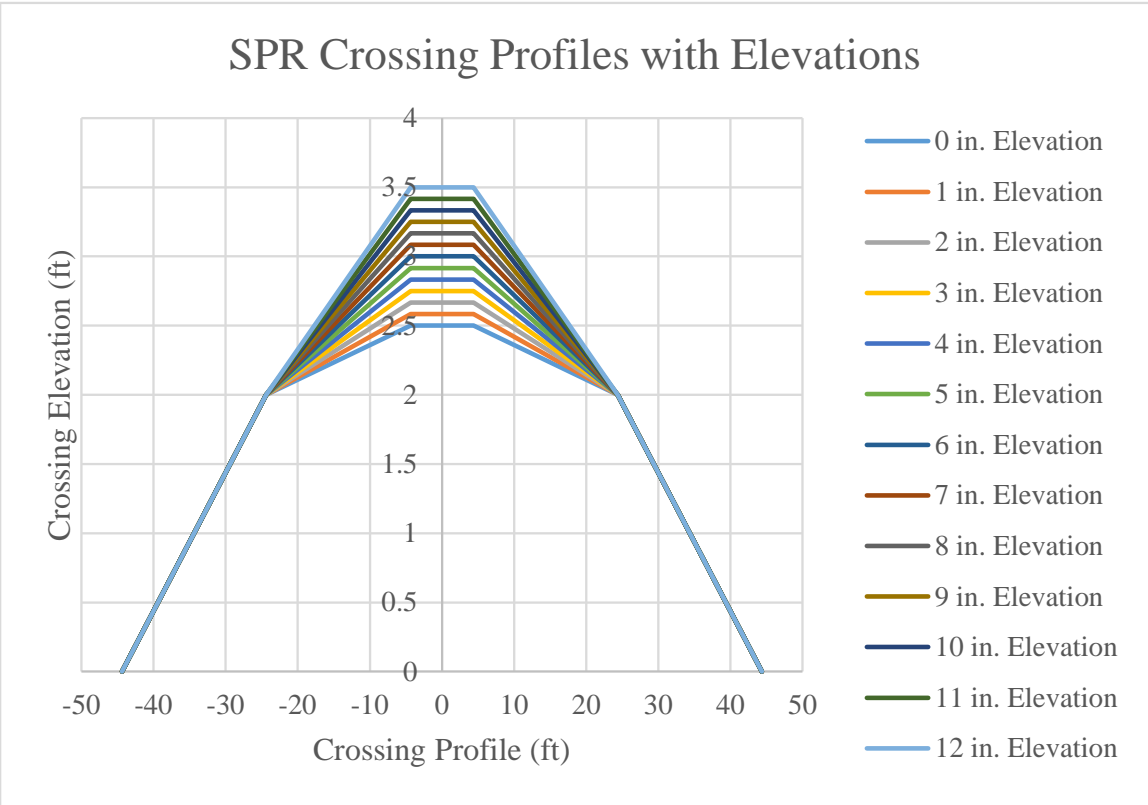

Figure 141. SPR Crossing Profiles Simulated with TruckSim



### 7.6.2 3D Scanned Crossings

Lastly, TruckSim was used to evaluate the real-world track geometries of the three scanned railroad tracks near Bellevue, Nebraska. The profiles for crossings 817404F, 817405M, and 816134F are shown in Figure 142. Each crossing profile was simulated for vehicles traversing from each approach side, referred to as original and reversed orientation. The original and reversed profiles for each crossing are shown in Figures 143 through 145.

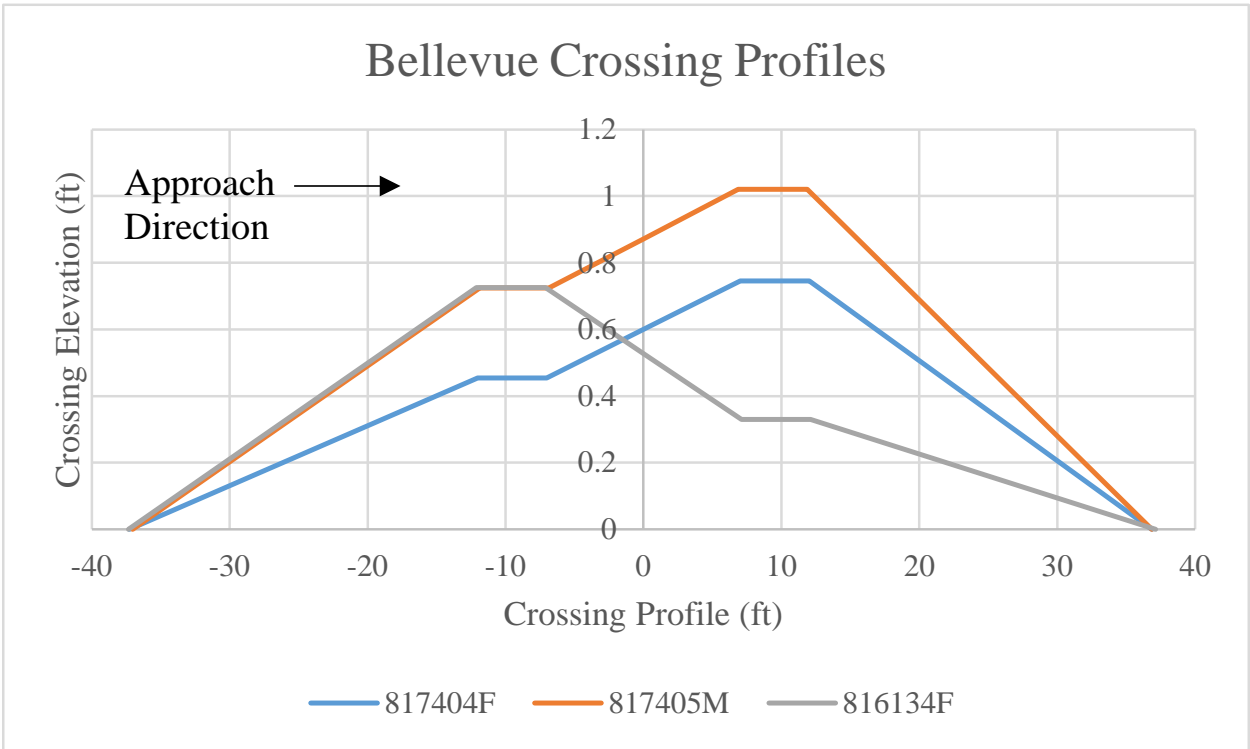

Figure 142. Bellevue Crossing Profiles Simulated with TruckSim

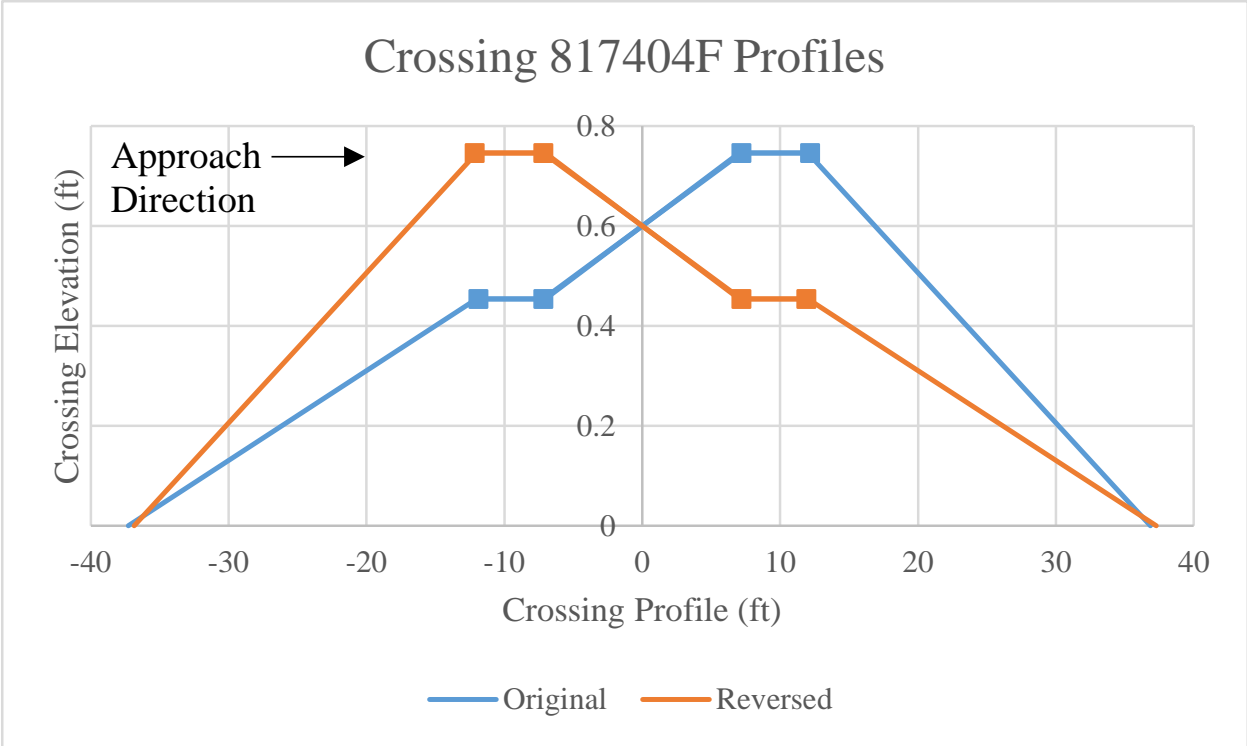

Figure 143. Crossing 817404F Profiles Simulated with TruckSim

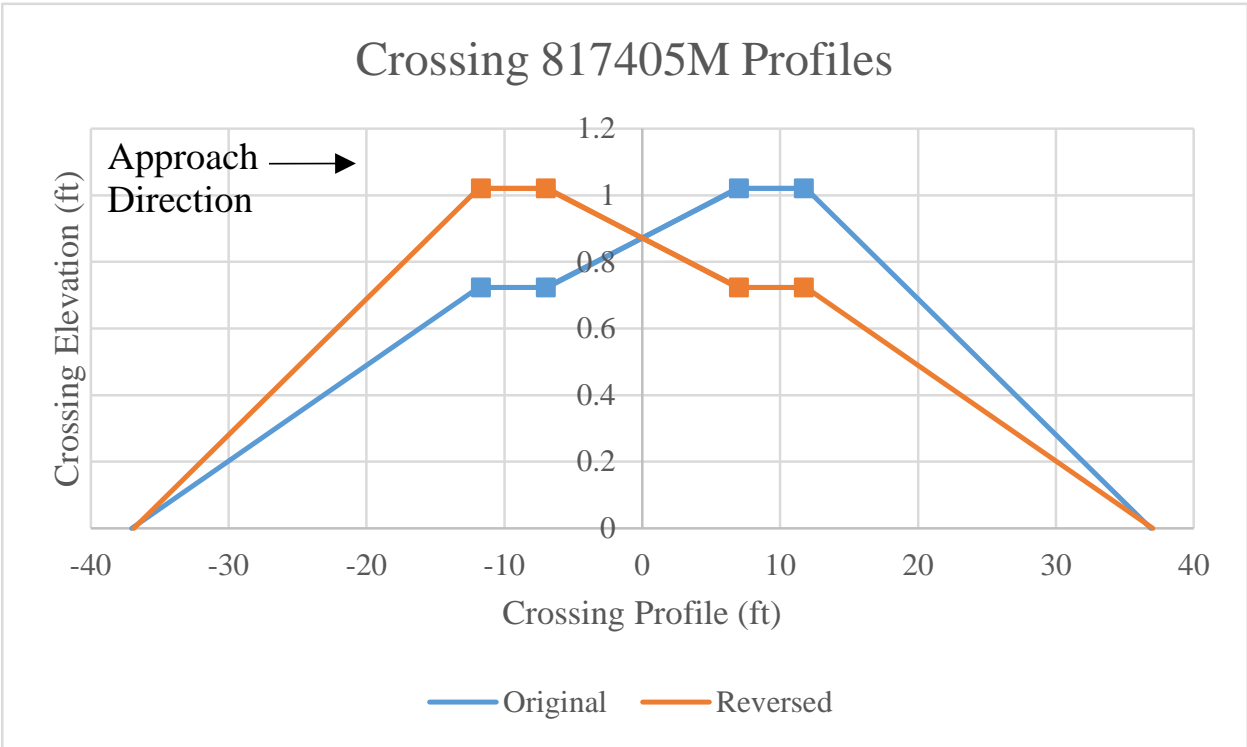

Figure 144. Crossing 817405M Profiles Simulated with TruckSim

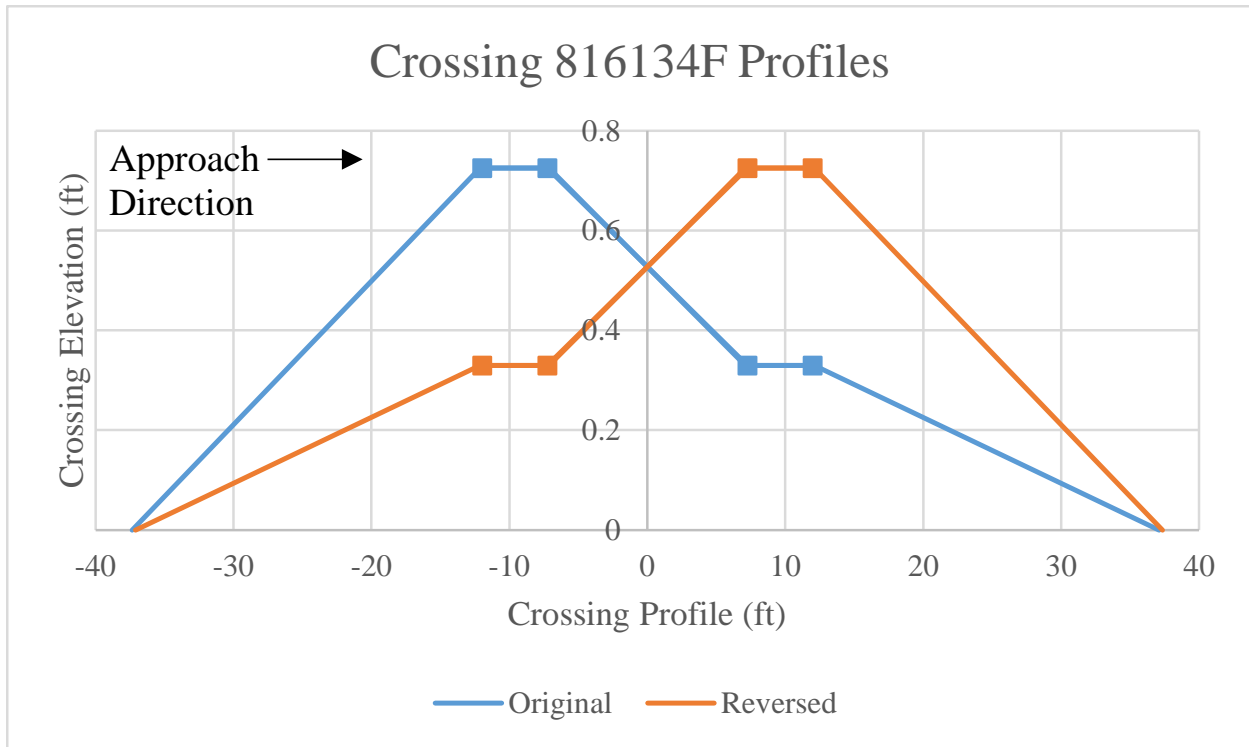

Figure 145. Crossing 816134F Profiles Simulated with TruckSim

### 7.7 Evaluation Criteria

Simulation results were analyzed qualitatively using a three-tier scale. If it appeared unlikely that a worst-case truck and trailer configuration would become high-centered, the simulation was coded as “green,” or likely safe. If the clearance between the crossing and trailer undercarriage dropped to less than 1 in. (25 mm), a warning flag was denoted using a “yellow” designation. Lastly, if it appeared likely that the trailer undercarriage would contact the crossing and would become high centered, the simulation was coded as “red,” or not safe, which was determined by visually observing an interference/intersection between the undercarriage of the trailer and at least one edge or surface of the track. A green (low-risk) vehicle-crossing simulation is shown in Figure 146, a yellow (moderate risk) crossing is shown in Figure 147, and a red (high risk) crossing is shown in Figure 148.

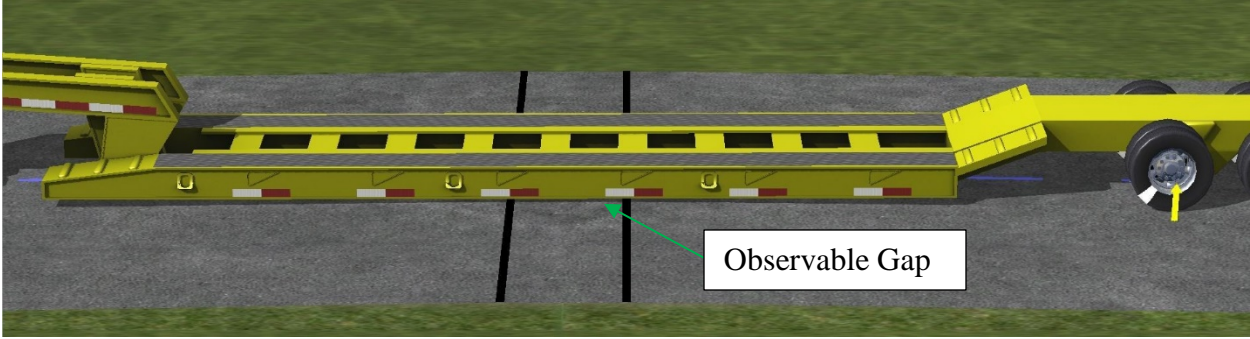

Figure 146. Green TruckSim Simulation

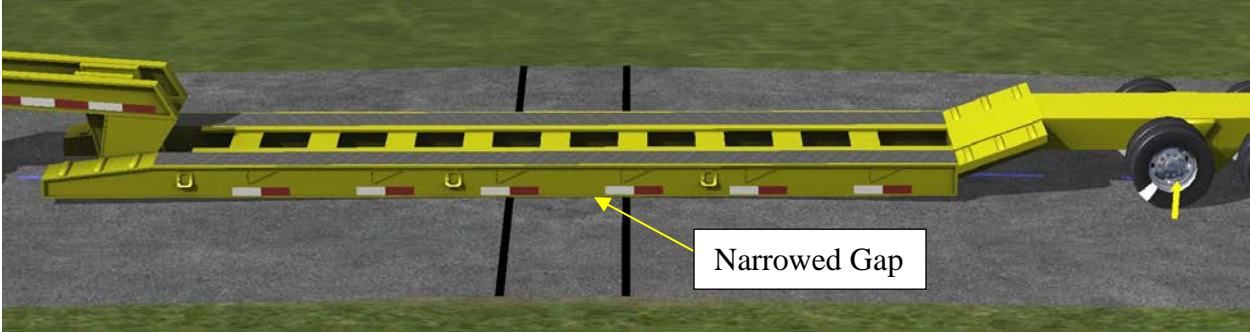

Figure 147. Yellow TruckSim Simulation

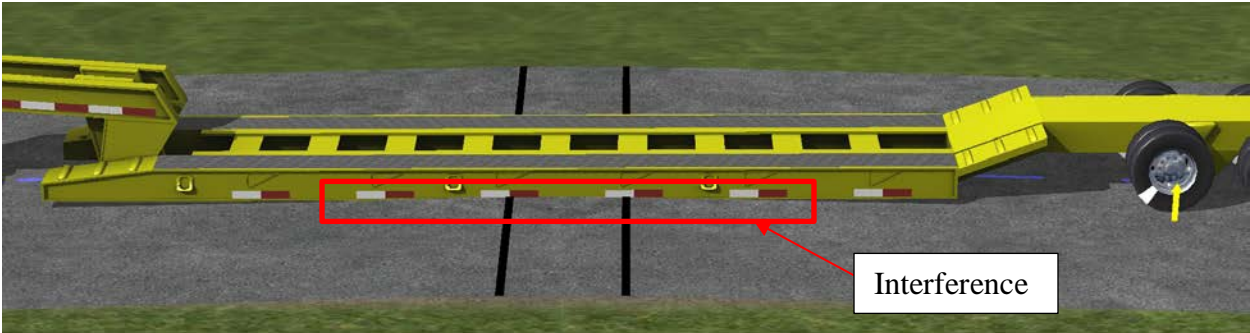

Figure 148. Red TruckSim Simulation

## 8 TRUCKSIM RESULTS AND DISCUSSION

### 8.1 Baseline Analysis of TruckSim Tractor-Box Trailer Model

To determine if suspension properties for vehicle models in TruckSim were accurate to model vehicles traversing crossings, four speed table simulations were performed. These simulations utilized identical traversal conditions as test nos. UTCRS-1 through UTCRS-4, which were discussed and analyzed in Chapter 3. Each test was simulated in TruckSim with a tractor-van trailer vehicle model similar to the vehicle which performed the live tests, shown in Figure 149. Vertical displacements and vertical acceleration of the trailer were collected and compared to those collected from the live speed table tests.



Figure 149. TruckSim Tractor-Van Trailer Model

Trailer axle displacements and suspension compression were graphed to determine the vertical displacement of the vehicle. The trailer displacement was equal to the axle displacement minus the suspension compression. The trailer's vertical acceleration was also graphed and compared to the vertical acceleration collected by the accelerometer for each test.

#### 8.1.1 Simulation of Test No. UTCRS-1

The vertical displacement of the two trailer axles is shown in Figure 150. The maximum displacements for axles 4 and 5 were 8.22 in. (209 mm) and 8.17 in. (208 mm), respectively. The average displacement was 8.20 in. (208 mm).



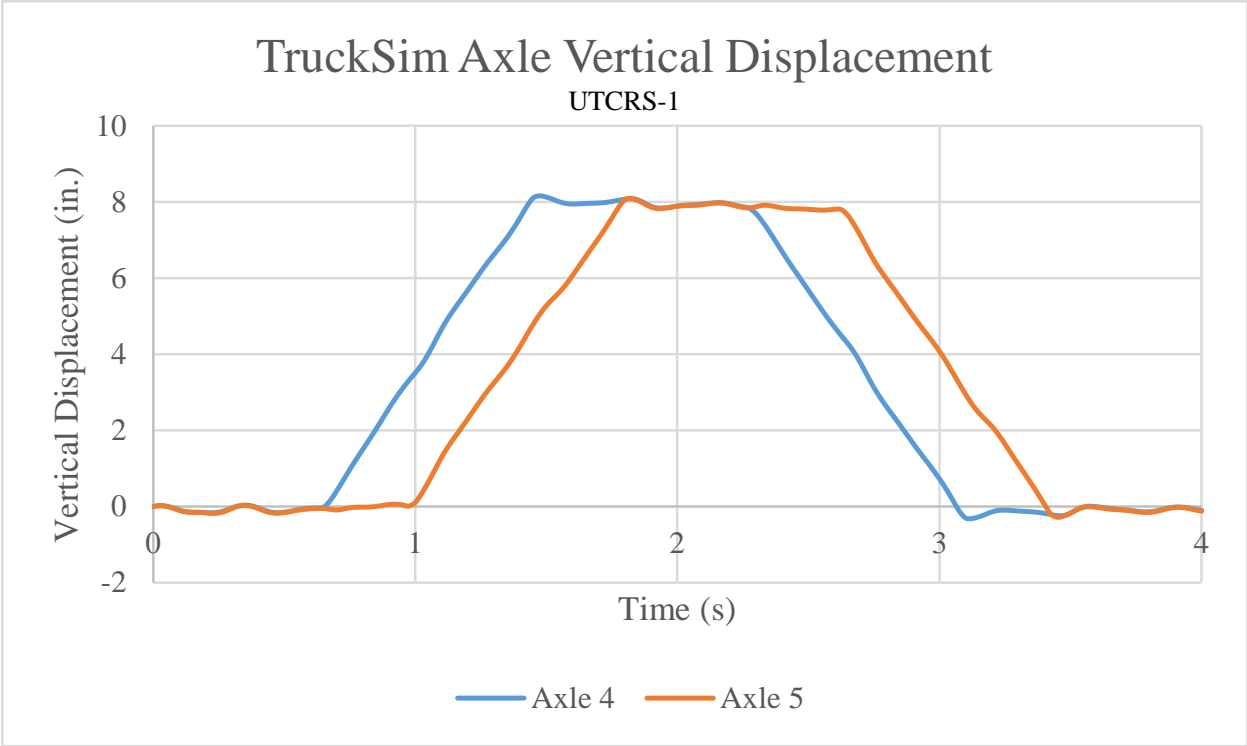

Figure 150. Vertical Displacement of Trailer Axles, Simulation of Test No. UTCRS-1

The suspension compression on the two trailer axles is shown in Figure 151. The spring compression on axles 4 and 5 at the time of maximum axle displacement were 0.13 in. (3.3 mm) and -0.22 in. (-5.7 mm), respectively. The average compression was 0.05 in. (1.2 mm).

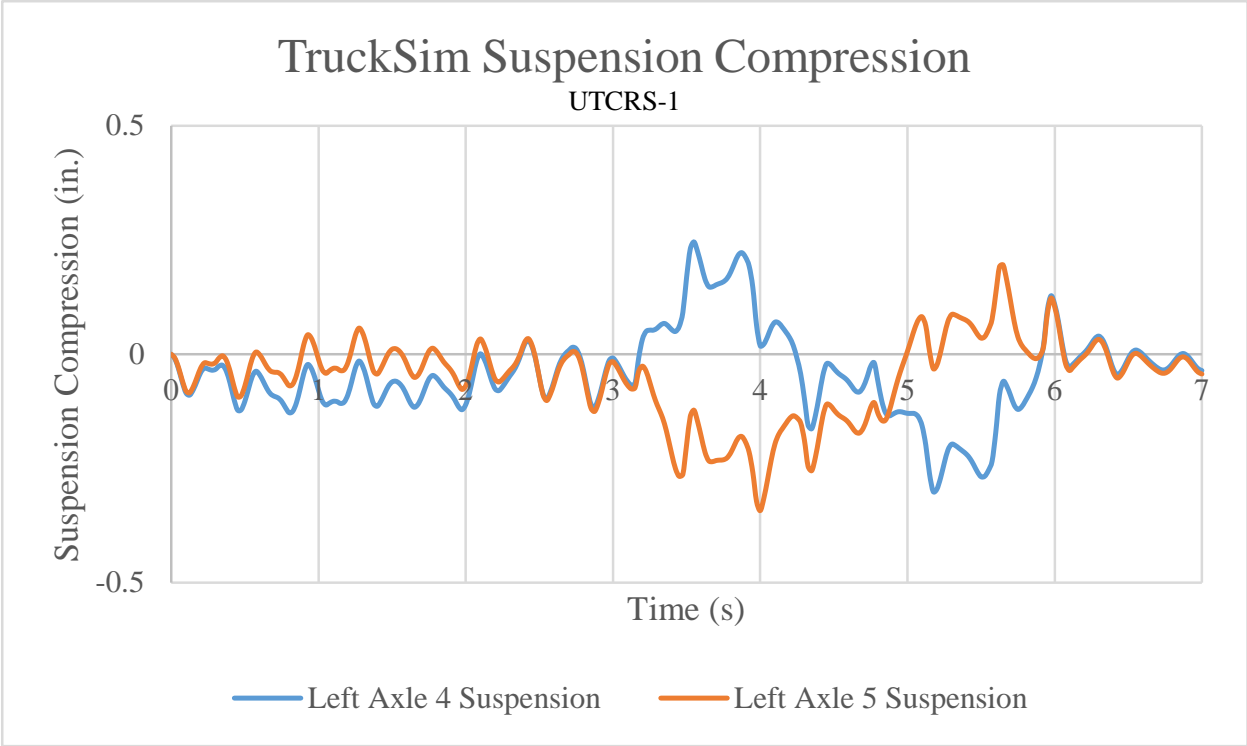

Figure 151. Suspension Compressions of Trailer Axles, Simulation of Test No. UTCRS-1

The vertical displacement of the trailer above axle 4 was 8.09 in. (206 mm) and above axle 5 was 8.39 in. (213 mm). The average vertical displacement for the trailer at the rear axles was 8.24 in. (209 mm).

The vertical acceleration of the trailer in the TruckSim simulation and in the live test is shown in Figure 152. The frequency response of the live test and simulation align at approximately 3.5 seconds until approximately 4.25 seconds, which suggests the stiffness of the trailer suspension in the live test and simulation were of the same value.

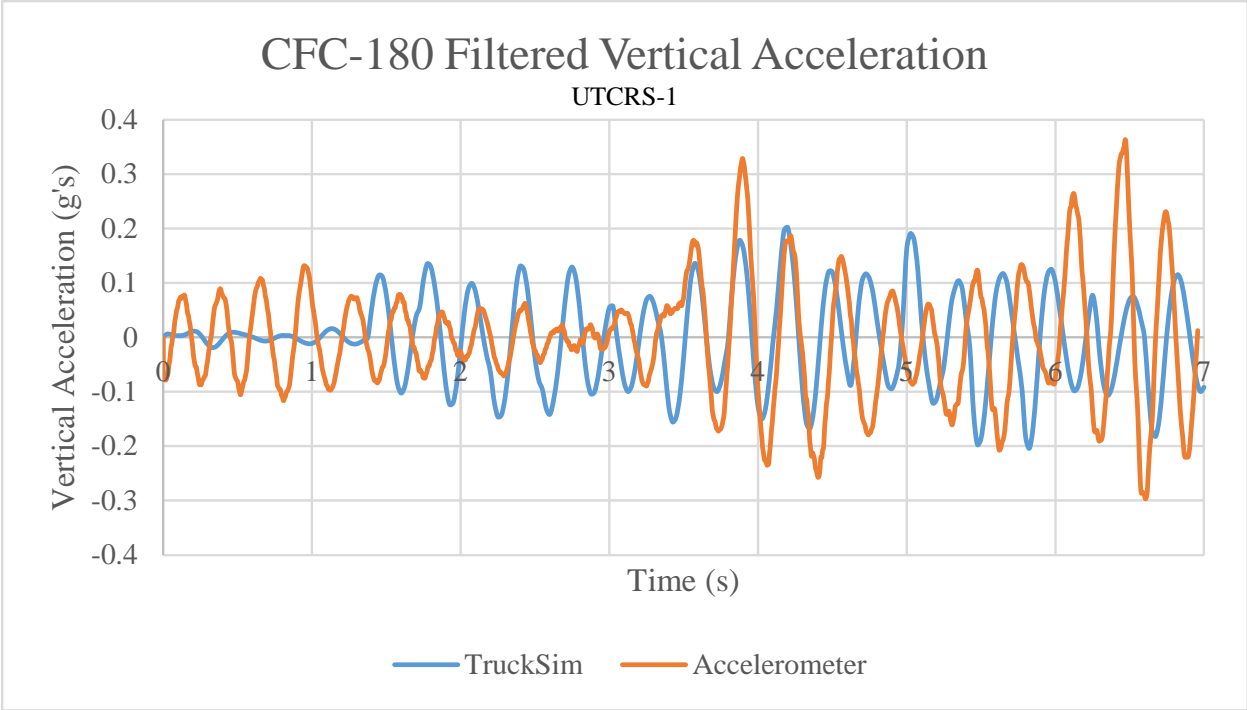

Figure 152. Vertical Acceleration of Van Trailer from TruckSim and Accelerometer, Test No. UTCRS-1

**8.1.2 Simulation of Test No. UTCRS-2**

The vertical displacement of the two trailer axles is shown in Figure 153. The maximum displacements for axles 4 and 5 were 8.17 in. (208 mm) and 8.09 in. (205 mm), respectively. The average displacement was 8.13 in. (207 mm).

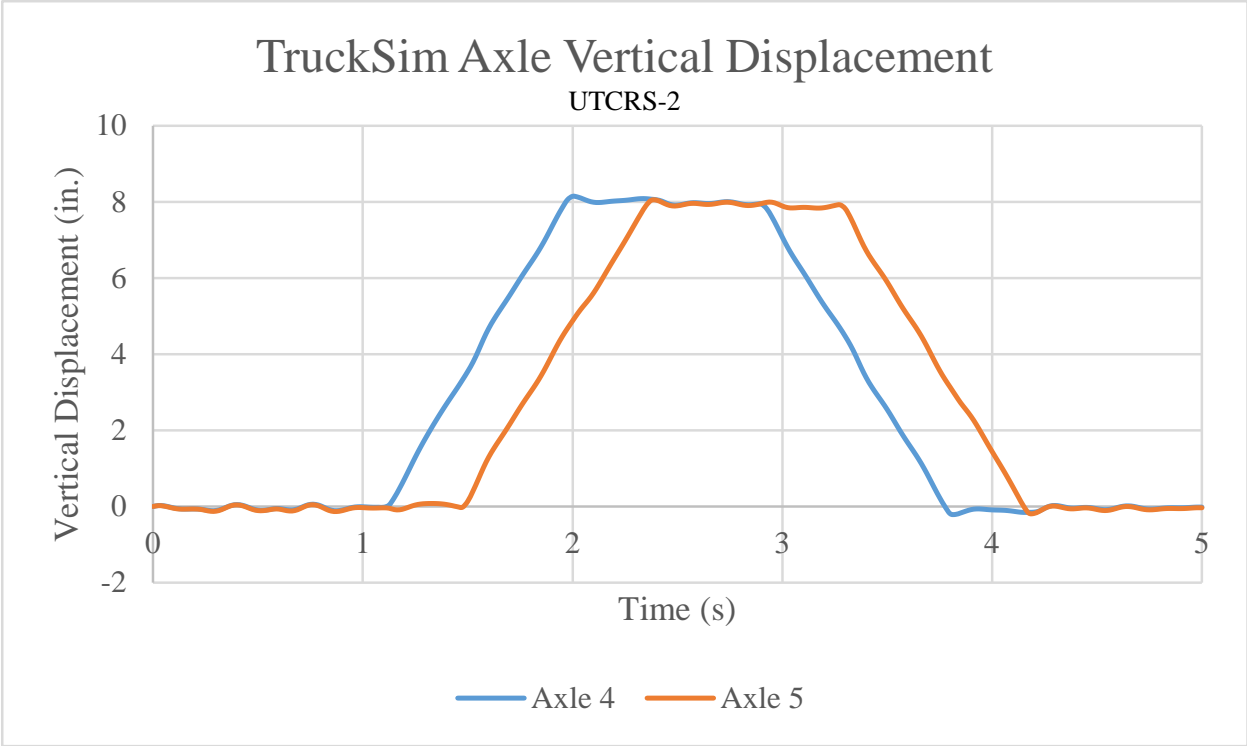

Figure 153. Vertical Displacement of Trailer Axles, Simulation of Test No. UTCRS-2

The suspension compression on the two trailer axles is shown in Figure 154. The spring compression on axles 4 and 5 at the time of maximum axle displacement were 0.16 in. (4.1 mm) and -0.16 in. (-4.09 mm), respectively. The average compression was 0.0008 in. (0.02 mm).

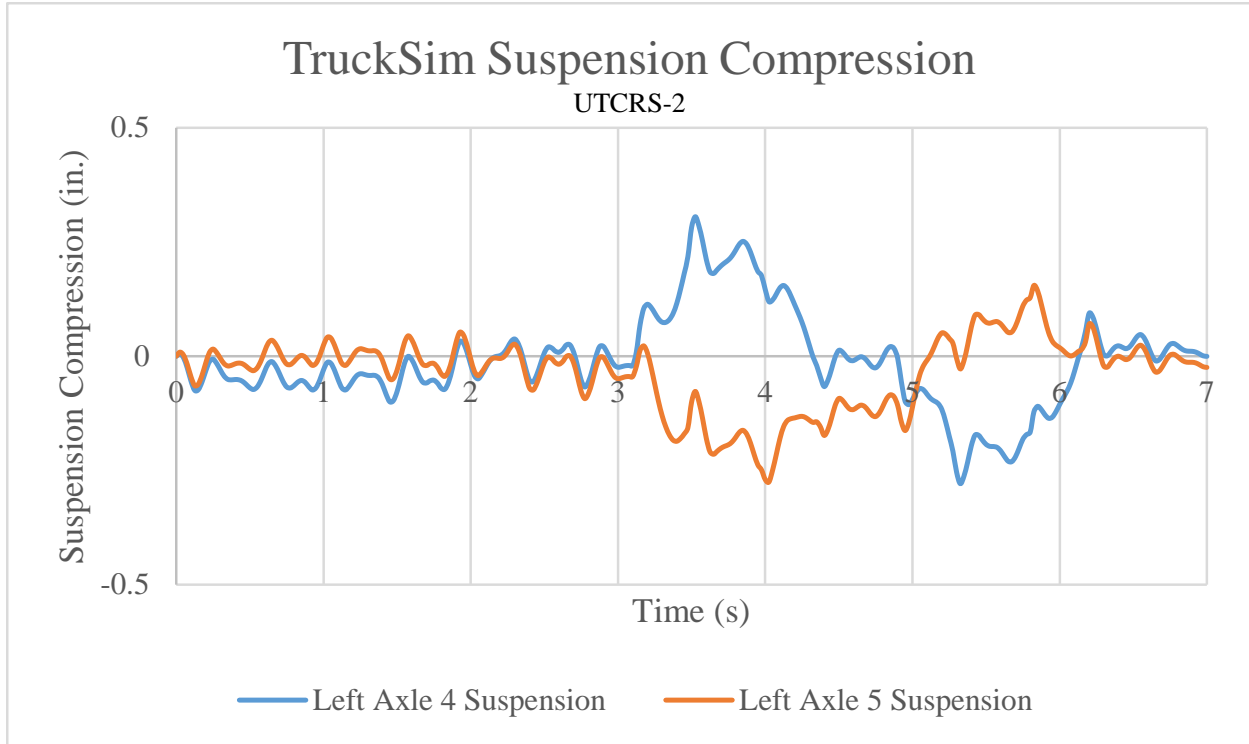

Figure 154. Suspension Compressions of Trailer Axles, Simulation of Test No. UTCRS-2

The vertical displacement of the trailer above axle 4 was 8.00 in. (203 mm) and above axle 5 was 8.25 in. (210 mm). The average vertical displacement for the trailer at the rear axles was 8.13 in. (206 mm).

The vertical acceleration of the trailer in the TruckSim simulation and in the live test is shown in Figure 155. The frequency response of the live test and simulation align at approximately 1.75 seconds until approximately 5.0 seconds, which suggests the stiffness of the trailer suspension in the live test and simulation were of the same value.



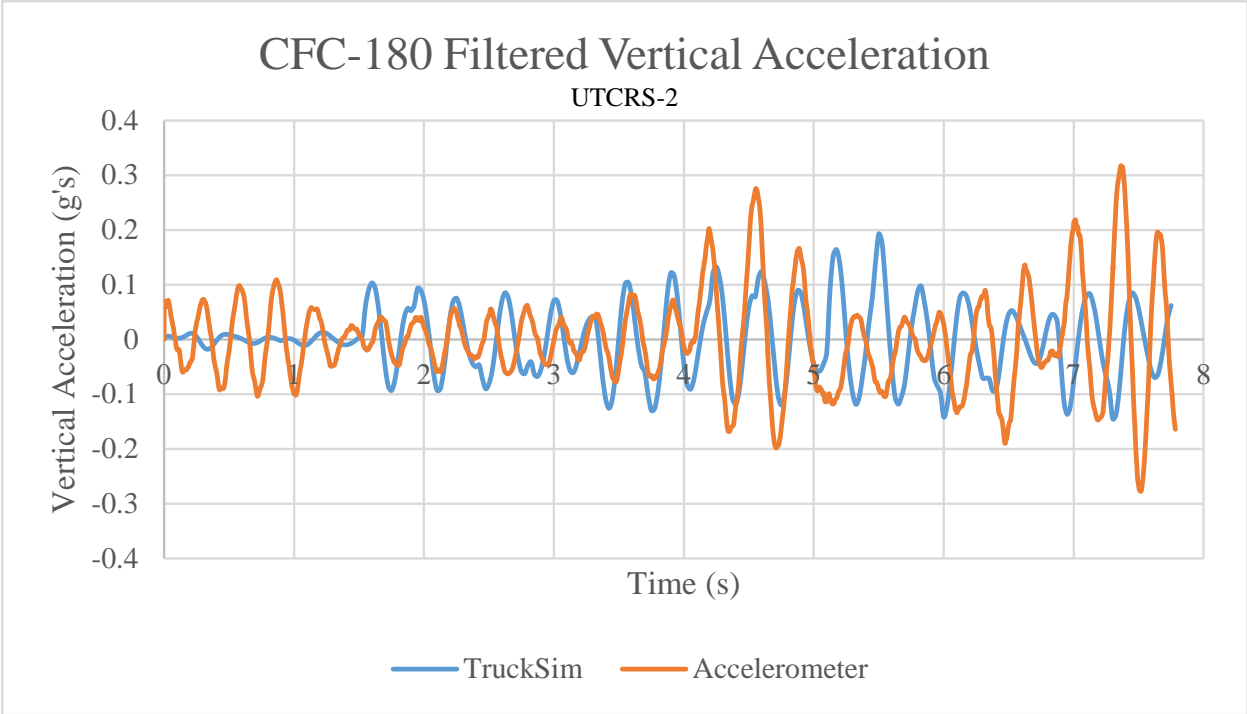

Figure 155. Vertical Acceleration of Van Trailer from TruckSim and Accelerometer, Test No. UTCRS-2

**8.1.3 Simulation of Test No. UTCRS-3**

The vertical displacement of the two trailer axles is shown in Figure 156. The maximum displacements for axles 4 and 5 were 8.16 in. (207 mm) and 8.10 in. (206 mm), respectively. The average displacement was 8.13 in. (207 mm).

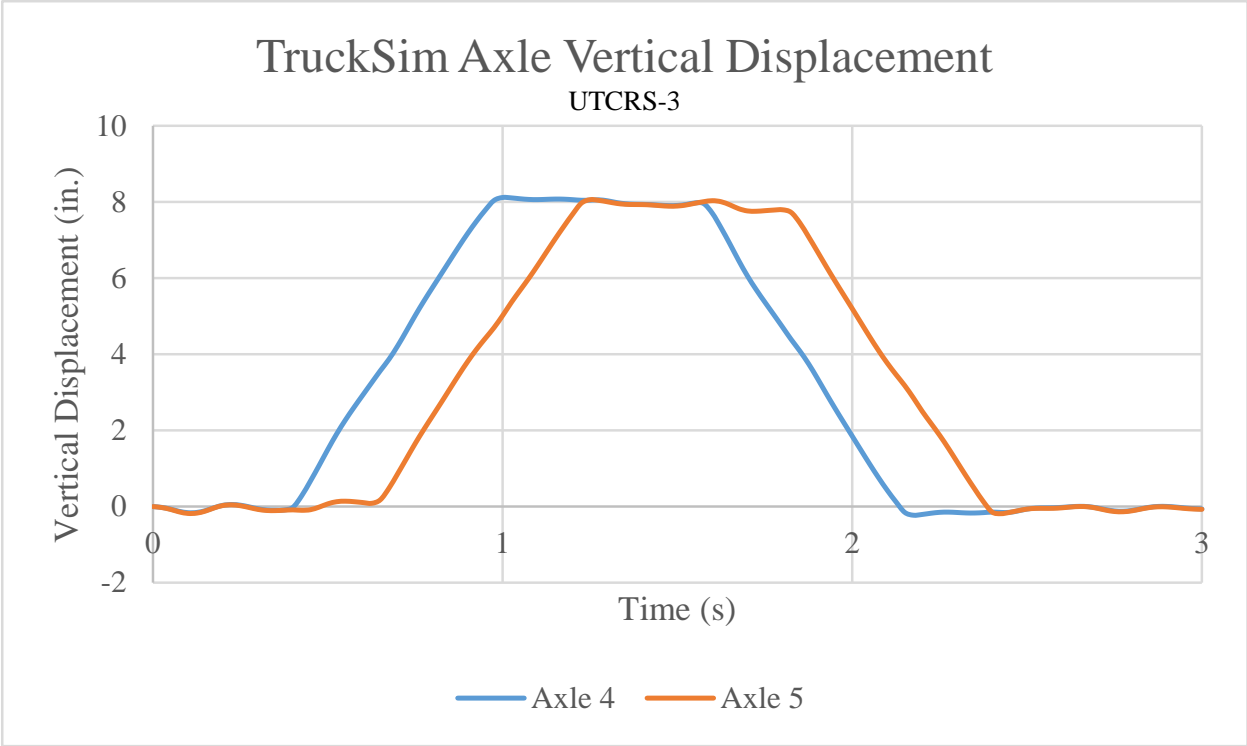

Figure 156. Vertical Displacement of Trailer Axles, Simulation of Test No. UTCRS-3

The suspension compression on the two trailer axles is shown in Figure 157. The spring compression on axles 4 and 5 at the time of maximum axle displacement were 0.21 in. (5.4 mm) and -0.12 in. (-3.1 mm), respectively. The average compression was 0.04 in. (1.1 mm).

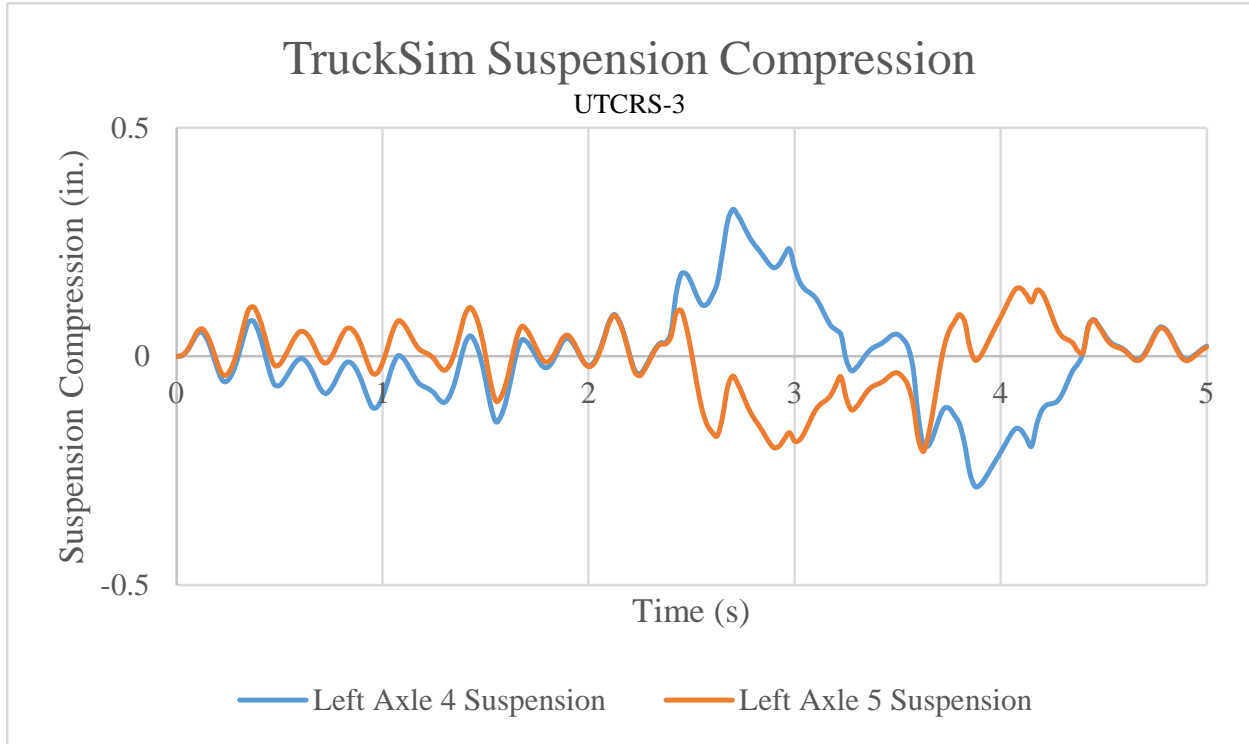

Figure 157. Suspension Compressions of Trailer Axles, Simulation of Test No. UTCRS-3

The vertical displacement of the trailer above axle 4 was 7.94 in. (202 mm) and above axle 5 was 8.23 in. (209 mm). The average vertical displacement for the trailer at the rear axles was 8.09 in. (205 mm).

The vertical acceleration of the trailer in the TruckSim simulation and in the live test is shown in Figure 158. The frequency response of the live test and simulation align at approximately 1.0 seconds until approximately 1.5 seconds, which suggests the stiffness of the trailer suspension in the live test and simulation were of the same value.

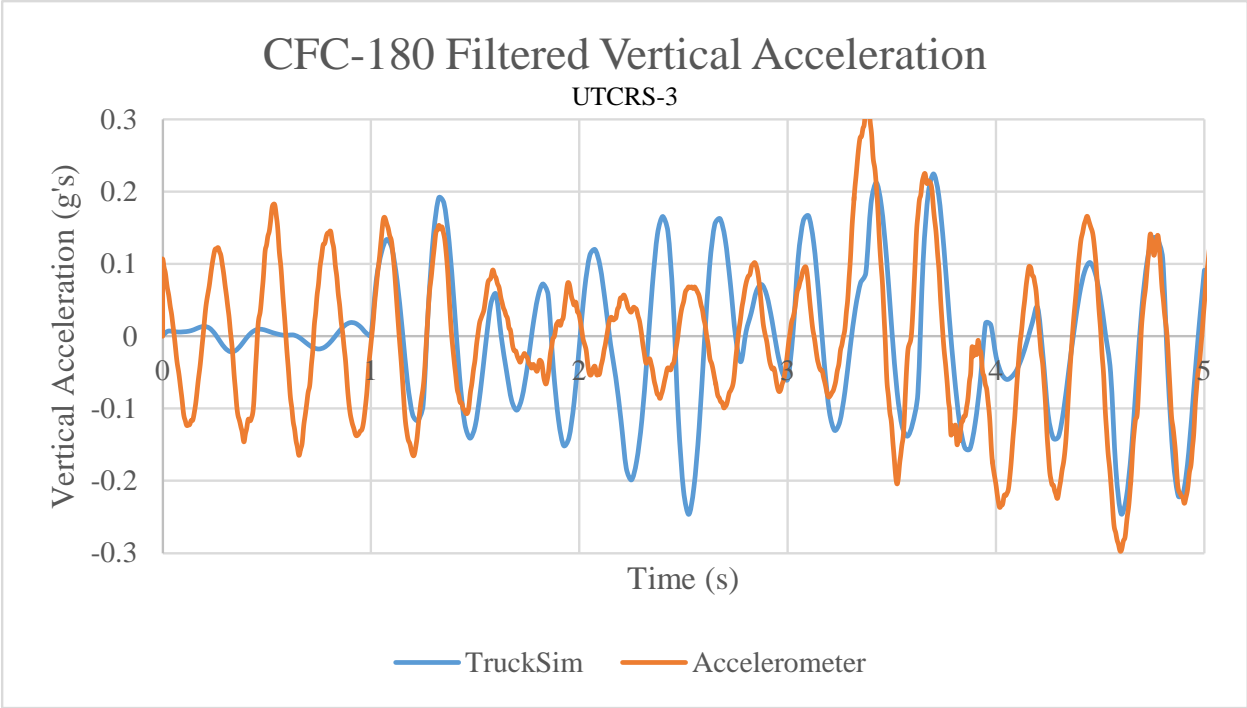

Figure 158. Vertical Acceleration of Van Trailer from TruckSim and Accelerometer, Test No. UTCRS-3

**8.1.4 Simulation of Test No. UTCRS-4**

The vertical displacement of the two trailer axles is shown in Figure 159. The maximum displacements for axles 4 and 5 were 8.24 in. (209 mm) and 8.14 in. (207 mm), respectively. The average displacement was 8.19 in. (208 mm).

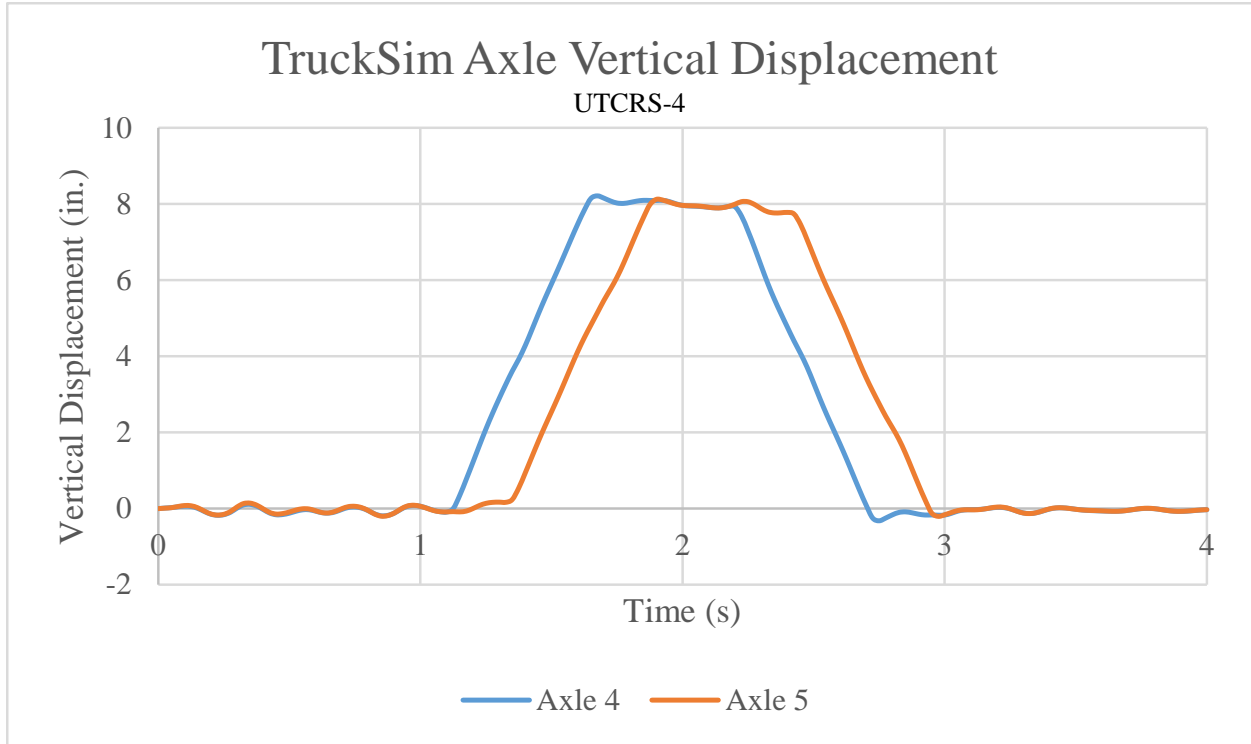

Figure 159. Vertical Displacement of Trailer Axles, Simulation of Test No. UTCRS-4

The suspension compression on the two trailer axles is shown in Figure 160. The spring compression on axles 4 and 5 at the time of maximum axle displacement were 0.15 in. (3.9 mm) and -0.15 in. (-3.9 mm), respectively. The average compression was 0.0004 in. (0.01 mm).



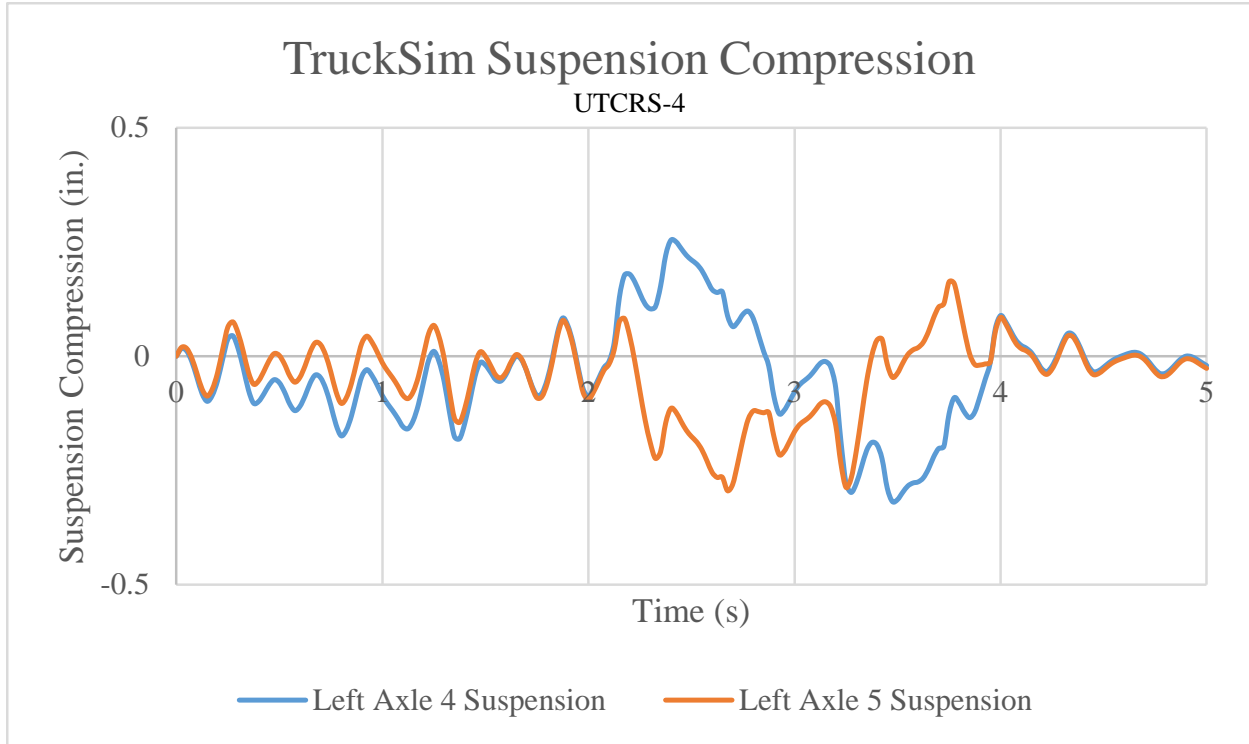

Figure 160. Suspension Compressions of Trailer Axles, Simulation of Test No. UTCRS-4

The vertical displacement of the trailer above axle 4 was 8.09 in. (205 mm) and above axle 5 was 8.30 in. (211 mm). The average vertical displacement for the trailer at the rear axles was 8.19 in. (208 mm).

The vertical acceleration of the trailer in the TruckSim simulation and in the live test is shown in Figure 161. The frequency response of the live test and simulation align at approximately 2.0 seconds until approximately 3.25 seconds, which suggests the stiffness of the trailer suspension in the live test and simulation were of the same value.

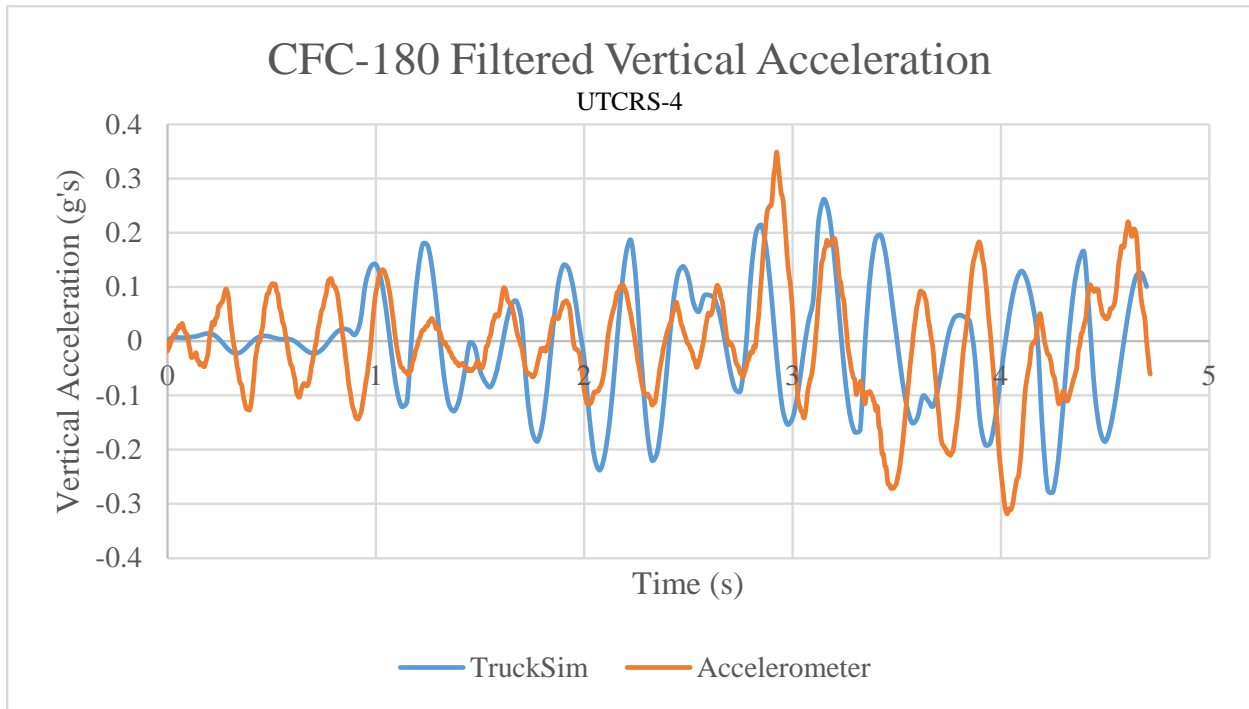

Figure 161. Vertical Acceleration of Van Trailer from TruckSim and Accelerometer, Test No. UTCRS-4

### 8.1.5 TruckSim Baseline Trailer Model Calibration Using Prior Data

The maximum vertical displacements from the speed table test and the TruckSim simulations are shown in Table 12, in addition to percent errors between the TruckSim vertical displacements and the speed table test vertical displacements. The percent error between the TruckSim and accelerometer displacements was 17.21 for test no. UTCRS-1, 28.84 for test no. UTCRS-2, 1.58 for test no. UTCRS-3, and 7.25 for test no. UTCRS-4. The percent error between the TruckSim and video analysis displacements was 13.50 for test no. UTCRS-1, 28.64 for test no. UTCRS-2, 14.10 for test no. UTCRS-3, and 17.67 for test no. UTCRS-4.

Table 12. Vertical Displacements and Percent Errors for Speed Table Tests and TruckSim Simulations

Test	Vertical Displacement in. (mm)			Percent Error	
	Accelerometer	Video Analysis	TruckSim	TruckSim to Accelerometer	TruckSim to Video Analysis
UTCRS-1	7.03 (179)	7.26 (184)	8.24 (209)	17.21	13.50
UTCRS-2	6.31 (160)	6.32 (161)	8.13 (207)	28.84	28.64
UTCRS-3	8.22 (209)	7.09 (180)	8.09 (205)	1.58	14.10
UTCRS-4	8.83 (224)	6.96 (177)	8.19 (208)	7.25	17.67

The error for all tests was less than 30 percent, therefore the suspension properties, ground clearance, and weight for the tractor-trailer vehicle model in TruckSim were not changed from their default values, which were pre-programmed into TruckSim. The vehicle models pre-programmed in TruckSim were used to evaluate if certain vehicles would become high-centered while traversing various crossing profiles, and the only vehicle property which was altered was the wheelbase.

## 8.2 AASHTO/AREMA (2015) Guideline Results

### 8.2.1 Dynamic Tractor with a Lowboy Trailer in TruckSim

TruckSim simulations were performed on thirteen AASHTO/AREMA (2015) and elevated AASHTO/AREMA (2015) guideline crossings with seventeen tractor-lowboy vehicle models. The results are shown in Table 13. The crossing with an elevation of 3 in. (76 mm) had no simulations suggesting vehicles could become high-centered. The crossings with elevations between 4 and 5 in. (102 and 127 mm) had warnings for trailers with wheelbases longer than 40 ft (12.2 m), but narrower wheelbases indicated no concerns. It was observed that contact was likely for vehicle undercarriages when tracks were raised to 8 to 12 in. (203 and 305 mm) above guidelines.

Table 13. AASHTO/AREMA (2015) Crossings with Tractor-Lowboy Trailer Vehicle Models

Wheelbase ft-in. (m)	Track Elevation in. (mm)												
	0	1 (25)	2 (51)	3 (76)	4 (102)	5 (127)	6 (152)	7 (178)	8 (203)	9 (229)	10 (254)	11 (279)	12 (305)
26-0 (7.9)	Green	Green	Green	Green	Green	Green	Green	Green	Yellow	Yellow	Yellow	Red	Red
28-0 (8.5)	Green	Green	Green	Green	Green	Green	Green	Green	Yellow	Yellow	Yellow	Red	Red
30-0 (9.1)	Green	Green	Green	Green	Green	Green	Green	Yellow	Yellow	Yellow	Red	Red	Red
32-0 (9.8)	Green	Green	Green	Green	Green	Green	Green	Yellow	Yellow	Red	Red	Red	Red
34-0 (10.4)	Green	Green	Green	Green	Green	Green	Yellow	Yellow	Yellow	Red	Red	Red	Red
36-0 (11.0)	Green	Green	Green	Green	Green	Green	Yellow	Yellow	Red	Red	Red	Red	Red
38-0 (11.6)	Green	Green	Green	Green	Green	Green	Yellow	Yellow	Red	Red	Red	Red	Red
40-0 (12.2)	Green	Green	Green	Green	Green	Yellow	Yellow	Red	Red	Red	Red	Red	Red
42-0 (12.8)	Green	Green	Green	Green	Green	Yellow	Yellow	Red	Red	Red	Red	Red	Red
44-0 (13.4)	Green	Green	Green	Green	Green	Yellow	Yellow	Red	Red	Red	Red	Red	Red
46-0 (14.0)	Green	Green	Green	Green	Yellow	Yellow	Red	Red	Red	Red	Red	Red	Red
48-0 (14.6)	Green	Green	Green	Green	Yellow	Yellow	Red	Red	Red	Red	Red	Red	Red
50-0 (15.2)	Green	Green	Green	Green	Yellow	Yellow	Red	Red	Red	Red	Red	Red	Red
53-8 (16.4)	Green	Green	Green	Green	Yellow	Yellow	Red	Red	Red	Red	Red	Red	Red
56-2 (17.1)	Green	Green	Green	Green	Yellow	Yellow	Red	Red	Red	Red	Red	Red	Red
61-1 (18.6)	Green	Green	Green	Green	Yellow	Yellow	Red	Red	Red	Red	Red	Red	Red
61-8 (18.8)	Green	Green	Green	Green	Yellow	Yellow	Red	Red	Red	Red	Red	Red	Red

### 8.2.2 Dynamic Bus in TruckSim

TruckSim simulations were performed on thirteen AASHTO/AREMA (2015) and elevated AASHTO/AREMA (2015) guideline crossings with nine bus vehicle models. The results are shown in Table 14. No AASHTO/AREMA (2015) or elevated AASHTO/AREMA (2015) crossing had the potential to cause any of the bus vehicle models to become high-centered.

Table 14. AASHTO/AREMA (2015) Crossings with Bus Vehicle Models

Wheelbase ft-in. (m)	Track Elevation in. (mm)												
	0	1 (25)	2 (51)	3 (76)	4 (102)	5 (127)	6 (152)	7 (178)	8 (203)	9 (229)	10 (254)	11 (279)	12 (305)
13-2 (4.0)	Green	Green	Green	Green	Green	Green	Green	Green	Green	Green	Green	Green	Green
17-4 (5.3)	Green	Green	Green	Green	Green	Green	Green	Green	Green	Green	Green	Green	Green
18-4 (5.6)	Green	Green	Green	Green	Green	Green	Green	Green	Green	Green	Green	Green	Green
21-0 (6.4)	Green	Green	Green	Green	Green	Green	Green	Green	Green	Green	Green	Green	Green
23-0 (7.0)	Green	Green	Green	Green	Green	Green	Green	Green	Green	Green	Green	Green	Green
24-1 (7.3)	Green	Green	Green	Green	Green	Green	Green	Green	Green	Green	Green	Green	Green
25-5 (7.7)	Green	Green	Green	Green	Green	Green	Green	Green	Green	Green	Green	Green	Green
26-6 (8.1)	Green	Green	Green	Green	Green	Green	Green	Green	Green	Green	Green	Green	Green
27-10.5 (8.5)	Green	Green	Green	Green	Green	Green	Green	Green	Green	Green	Green	Green	Green

### 8.3 AREMA (1990) Guideline Results

#### 8.3.1 Static Tractor with a Lowboy Trailer in AutoCAD

The results of the static analysis for the AREMA (1990) and elevated AREMA (1990) crossings are shown in Table 15.

Table 15. Static Analysis of AREMA (1990) Crossings with Tractor-Lowboy Trailer Vehicle Models

Wheelbase ft-in. (m)	Track Elevation in. (mm)												
	0	1 (25)	2 (51)	3 (76)	4 (102)	5 (127)	6 (152)	7 (178)	8 (203)	9 (229)	10 (254)	11 (279)	12 (305)
26-0 (7.9)	0.91 (23)	1.21 (31)	1.15 (38)	1.81 (46)	2.11 (54)	2.41 (61)	2.72 (69)	3.02 (77)	3.32 (84)	3.62 (92)	3.92 (100)	4.23 (107)	4.53 (115)
28-0 (8.5)	1.01 (26)	1.35 (34)	1.69 (43)	2.03 (51)	2.36 (60)	2.70 (69)	3.04 (77)	3.38 (86)	3.72 (94)	4.05 (103)	4.39 (111)	4.73 (120)	5.06 (129)
30-0 (9.1)	1.12 (28)	1.49 (38)	1.87 (47)	2.24 (57)	2.61 (66)	2.99 (76)	3.36 (85)	3.74 (95)	4.11 (104)	4.48 (114)	4.86 (123)	5.23 (133)	5.60 (142)
32-0 (9.8)	1.23 (31)	1.64 (42)	2.05 (52)	2.46 (62)	2.87 (73)	3.27 (83)	3.69 (94)	4.09 (104)	4.50 (114)	4.91 (125)	5.32 (135)	5.73 (146)	6.14 (156)
34-0 (10.4)	1.34 (34)	1.78 (45)	2.23 (57)	2.67 (68)	3.12 (79)	3.56 (90)	4.01 (102)	4.45 (113)	4.90 (124)	5.34 (136)	5.79 (147)	6.23 (158)	6.68 (170)
36-0 (11.0)	1.44 (37)	1.92 (49)	2.41 (61)	2.89 (73)	3.37 (86)	3.85 (98)	4.33 (110)	4.81 (122)	5.29 (134)	5.77 (147)	6.25 (159)	6.74 (171)	7.21 (183)
38-0 (11.6)	1.55 (39)	2.07 (53)	2.58 (66)	3.10 (79)	3.62 (92)	4.14 (105)	4.65 (118)	5.17 (131)	5.69 (144)	6.20 (158)	6.72 (171)	7.24 (184)	7.75 (197)
40-0 (12.2)	1.65 (42)	2.21 (56)	2.76 (70)	3.32 (84)	3.87 (98)	4.43 (112)	4.98 (126)	5.53 (140)	6.08 (154)	6.63 (169)	7.19 (183)	7.74 (197)	8.29 (211)
42-0 (12.8)	1.77 (45)	2.35 (60)	2.94 (75)	3.53 (90)	4.12 (105)	4.71 (120)	5.30 (135)	5.89 (150)	6.47 (164)	7.06 (179)	7.65 (194)	8.24 (209)	8.83 (224)

### **8.3.2 Dynamic Tractor with a Lowboy Trailer in TruckSim**

TruckSim simulations were performed on thirteen AREMA (1990) and elevated AREMA (1990) guideline crossings with seventeen tractor-lowboy vehicle models. The results are shown in Table 16. The nominal AREMA (1990) specifications were determined to be satisfactory. Warnings were noted for long wheelbase trailers when crossing geometries were increased by only 1 to 2 in. (25 to 51 mm). When track heights were 4 in. (102 mm) higher than nominal AREMA (1990) guidelines, at least one of the trailer wheelbases were likely to become high-centered. Trailer undercarriage contacts appeared to be concerning for all wheelbases for crossing geometries in which the center of the tracks were raised 7 in. (178 mm) above nominal AREMA (1990) guidelines. Simulation results indicated AREMA (1990) crossings with elevations between 4 and 12 in. (102 and 305 mm) could potentially cause vehicles to become high-centered. In general, more at-risk crossings were identified using the dynamic analysis than the static analysis.



Table 16. AREMA (1990) Crossings with Tractor-Lowboy Trailer Vehicle Models

Wheelbase ft-in. (m)	Track Elevation in. (mm)												
	0	1 (25)	2 (51)	3 (76)	4 (102)	5 (127)	6 (152)	7 (178)	8 (203)	9 (229)	10 (254)	11 (279)	12 (305)
26-0 (7.9)	Green	Green	Green	Green	Yellow	Yellow	Yellow	Red	Red	Red	Red	Red	Red
28-0 (8.5)	Green	Green	Green	Green	Yellow	Yellow	Red	Red	Red	Red	Red	Red	Red
30-0 (9.1)	Green	Green	Green	Yellow	Yellow	Yellow	Red	Red	Red	Red	Red	Red	Red
32-0 (9.8)	Green	Green	Green	Yellow	Yellow	Red	Red	Red	Red	Red	Red	Red	Red
34-0 (10.4)	Green	Green	Green	Yellow	Red	Red	Red	Red	Red	Red	Red	Red	Red
36-0 (11.0)	Green	Green	Yellow	Yellow	Red	Red	Red	Red	Red	Red	Red	Red	Red
38-0 (11.6)	Green	Yellow	Yellow	Yellow	Red	Red	Red	Red	Red	Red	Red	Red	Red
40-0 (12.2)	Green	Yellow	Yellow	Yellow	Red	Red	Red	Red	Red	Red	Red	Red	Red
42-0 (12.8)	Green	Yellow	Yellow	Red	Red	Red	Red	Red	Red	Red	Red	Red	Red
44-0 (13.4)	Green	Yellow	Yellow	Red	Red	Red	Red	Red	Red	Red	Red	Red	Red
46-0 (14.0)	Green	Yellow	Yellow	Red	Red	Red	Red	Red	Red	Red	Red	Red	Red
48-0 (14.6)	Green	Yellow	Yellow	Red	Red	Red	Red	Red	Red	Red	Red	Red	Red
50-0 (15.2)	Green	Yellow	Yellow	Red	Red	Red	Red	Red	Red	Red	Red	Red	Red
53-8 (16.4)	Green	Yellow	Yellow	Red	Red	Red	Red	Red	Red	Red	Red	Red	Red
56-2 (17.1)	Green	Yellow	Yellow	Red	Red	Red	Red	Red	Red	Red	Red	Red	Red
61-1 (18.6)	Green	Yellow	Yellow	Red	Red	Red	Red	Red	Red	Red	Red	Red	Red
61-8 (18.8)	Green	Yellow	Yellow	Red	Red	Red	Red	Red	Red	Red	Red	Red	Red

### 8.3.3 Dynamic Bus in TruckSim

TruckSim simulations were performed on thirteen AREMA (1990) and elevated AREMA (1990) guideline crossings with nine bus vehicle models. The results are shown in Table 17. No AREMA (1990) or elevated AREMA (1990) crossing had the potential to cause any of the bus vehicle models to become high-centered.

Table 17. AREMA (1990) Crossings with Bus Vehicle Models

Wheelbase ft-in. (m)	Track Elevation in. (mm)												
	0	1 (25)	2 (51)	3 (76)	4 (102)	5 (127)	6 (152)	7 (178)	8 (203)	9 (229)	10 (254)	11 (279)	12 (305)
13-2 (4.0)	Green	Green	Green	Green	Green	Green	Green	Green	Green	Green	Green	Green	Green
17-4 (5.3)	Green	Green	Green	Green	Green	Green	Green	Green	Green	Green	Green	Green	Green
18-4 (5.6)	Green	Green	Green	Green	Green	Green	Green	Green	Green	Green	Green	Green	Green
21-0 (6.4)	Green	Green	Green	Green	Green	Green	Green	Green	Green	Green	Green	Green	Green
23-0 (7.0)	Green	Green	Green	Green	Green	Green	Green	Green	Green	Green	Green	Green	Green
24-1 (7.3)	Green	Green	Green	Green	Green	Green	Green	Green	Green	Green	Green	Green	Green
25-5 (7.7)	Green	Green	Green	Green	Green	Green	Green	Green	Green	Green	Green	Green	Green
26-6 (8.1)	Green	Green	Green	Green	Green	Green	Green	Green	Green	Green	Green	Green	Green
27-10.5 (8.5)	Green	Green	Green	Green	Green	Green	Green	Green	Green	Green	Green	Green	Green

## 8.4 ICC Guideline Results

### 8.4.1 Static Tractor with a Lowboy Trailer in AutoCAD

The results of the static analysis for the AASHTO and elevated AASHTO crossings are shown in Table 18.

Table 18. Static Analysis of ICC Crossings with Tractor-Lowboy Trailer Vehicle Models

Wheelbase ft-in. (m)	Track Elevation in. (mm)												
	0	1 (25)	2 (51)	3 (76)	4 (102)	5 (127)	6 (152)	7 (178)	8 (203)	9 (229)	10 (254)	11 (279)	12 (305)
26-0 (7.9)	1.01 (26)	1.35 (34)	1.68 (43)	2.02 (51)	2.36 (60)	2.69 (68)	3.03 (77)	3.37 (86)	3.70 (94)	4.04 (103)	4.38 (111)	4.71 (120)	5.05 (128)
28-0 (8.5)	1.13 (29)	1.51 (38)	1.88 (48)	2.26 (57)	2.64 (67)	3.01 (77)	3.39 (86)	3.77 (96)	4.14 (105)	4.52 (115)	4.90 (124)	5.27 (134)	5.65 (143)
30-0 (9.1)	1.25 (32)	1.67 (42)	2.08 (53)	2.50 (63)	2.92 (74)	3.33 (85)	3.75 (95)	4.17 (106)	4.58 (116)	5.00 (127)	5.42 (138)	5.83 (148)	6.25 (159)
32-0 (9.8)	1.37 (35)	1.83 (46)	2.28 (58)	2.74 (70)	3.20 (81)	3.65 (93)	4.11 (104)	4.57 (116)	5.02 (128)	5.48 (139)	5.94 (151)	6.39 (162)	6.85 (174)
34-0 (10.4)	1.49 (38)	1.99 (50)	2.48 (63)	2.98 (76)	3.48 (88)	3.97 (101)	4.47 (114)	4.97 (126)	5.46 (139)	5.95 (151)	6.46 (165)	6.95 (177)	7.45 (189)
36-0 (11.0)	1.16 (41)	2.15 (55)	2.68 (68)	3.22 (82)	3.76 (95)	4.29 (109)	4.83 (123)	5.37 (136)	5.90 (150)	6.44 (164)	6.98 (177)	7.51 (191)	8.05 (204)
38-0 (11.6)	1.73 (44)	2.31 (59)	2.88 (73)	3.46 (88)	4.04 (103)	4.61 (117)	5.19 (132)	5.77 (146)	6.34 (161)	6.92 (176)	7.50 (190)	8.07 (205)	8.65 (220)
40-0 (12.2)	1.85 (47)	2.47 (63)	3.08 (78)	3.70 (94)	4.32 (110)	4.93 (125)	5.55 (141)	6.17 (157)	6.78 (172)	7.40 (188)	8.02 (204)	8.63 (219)	9.25 (235)
42-0 (12.8)	1.97 (50)	2.63 (67)	3.28 (83)	3.94 (100)	4.60 (117)	5.25 (133)	5.91 (150)	6.57 (167)	7.22 (183)	7.88 (200)	8.54 (217)	9.19 (234)	9.85 (250)

### 8.4.2 Dynamic Tractor with a Lowboy Trailer in TruckSim

TruckSim simulations were performed on thirteen ICC and elevated ICC guideline crossings with seventeen tractor-lowboy vehicle models. The results are shown in Table 19. Surprisingly, even for crossings in which the road shape satisfied the ICC specifications, at least one trailer wheelbase was determined to be likely to become high-centered. Compared to the static analysis, more crossings were determined to be at risk of causing high-centered trailers under dynamic conditions than static conditions.

Table 19. ICC Crossings with Tractor-Lowboy Trailer Vehicle Models

Wheelbase ft-in. (m)	Track Elevation in. (mm)												
	0	1 (25)	2 (51)	3 (76)	4 (102)	5 (127)	6 (152)	7 (178)	8 (203)	9 (229)	10 (254)	11 (279)	12 (305)
26-0 (7.9)	Green	Green	Green	Green	Green	Green	Yellow	Yellow	Red	Red	Red	Red	Red
28-0 (8.5)	Green	Green	Green	Green	Green	Green	Yellow	Yellow	Red	Red	Red	Red	Red
30-0 (9.1)	Green	Green	Green	Green	Green	Green	Yellow	Yellow	Red	Red	Red	Red	Red
32-0 (9.8)	Green	Green	Green	Green	Green	Yellow	Yellow	Red	Red	Red	Red	Red	Red
34-0 (10.4)	Green	Green	Green	Green	Green	Yellow	Red	Red	Red	Red	Red	Red	Red
36-0 (11.0)	Green	Green	Green	Green	Yellow	Yellow	Red	Red	Red	Red	Red	Red	Red
38-0 (11.6)	Green	Green	Green	Green	Yellow	Yellow	Red	Red	Red	Red	Red	Red	Red
40-0 (12.2)	Green	Green	Green	Yellow	Yellow	Red	Red	Red	Red	Red	Red	Red	Red
42-0 (12.8)	Green	Green	Green	Yellow	Yellow	Red	Red	Red	Red	Red	Red	Red	Red
44-0 (13.4)	Green	Green	Green	Yellow	Yellow	Red	Red	Red	Red	Red	Red	Red	Red
46-0 (14.0)	Green	Yellow	Yellow	Yellow	Red	Red	Red	Red	Red	Red	Red	Red	Red
48-0 (14.6)	Yellow	Yellow	Yellow	Yellow	Red	Red	Red	Red	Red	Red	Red	Red	Red
50-0 (15.2)	Yellow	Yellow	Yellow	Red	Red	Red	Red	Red	Red	Red	Red	Red	Red
53-8 (16.4)	Yellow	Yellow	Red	Red	Red	Red	Red	Red	Red	Red	Red	Red	Red
56-2 (17.1)	Yellow	Yellow	Red	Red	Red	Red	Red	Red	Red	Red	Red	Red	Red
61-1 (18.6)	Red	Red	Red	Red	Red	Red	Red	Red	Red	Red	Red	Red	Red
61-8 (18.8)	Red	Red	Red	Red	Red	Red	Red	Red	Red	Red	Red	Red	Red

### 8.4.3 Dynamic Bus in TruckSim

TruckSim simulations were performed on thirteen ICC and elevated ICC guideline crossings with nine bus vehicle models. The results are shown in Table 20. No ICC or elevated ICC crossings had the potential to cause any of the bus vehicle models to become high-centered.

Table 20. ICC Crossings with Bus Vehicle Models

Wheelbase ft-in. (m)	Track Elevation in. (mm)												
	0	1 (25)	2 (51)	3 (76)	4 (102)	5 (127)	6 (152)	7 (178)	8 (203)	9 (229)	10 (254)	11 (279)	12 (305)
13-2 (4.0)	Green	Green	Green	Green	Green	Green	Green	Green	Green	Green	Green	Green	Green
17-4 (5.3)	Green	Green	Green	Green	Green	Green	Green	Green	Green	Green	Green	Green	Green
18-4 (5.6)	Green	Green	Green	Green	Green	Green	Green	Green	Green	Green	Green	Green	Green
21-0 (6.4)	Green	Green	Green	Green	Green	Green	Green	Green	Green	Green	Green	Green	Green
23-0 (7.0)	Green	Green	Green	Green	Green	Green	Green	Green	Green	Green	Green	Green	Green
24-1 (7.3)	Green	Green	Green	Green	Green	Green	Green	Green	Green	Green	Green	Green	Green
25-5 (7.7)	Green	Green	Green	Green	Green	Green	Green	Green	Green	Green	Green	Green	Green
26-6 (8.1)	Green	Green	Green	Green	Green	Green	Green	Green	Green	Green	Green	Green	Green
27-10.5 (8.5)	Green	Green	Green	Green	Green	Green	Green	Green	Green	Green	Green	Green	Green

## 8.5 SPR Guideline Results

### 8.5.1 Static Tractor with a Lowboy Trailer in AutoCAD

The results of the static analysis for the AASHTO and elevated AASHTO crossings are shown in Table 21. Static analysis suggested that many truck-trailer combinations would be capable of successfully navigating truck-trailer crossings which are compliant with SPR guidelines, but very long wheelbase trailers were likely to experience problems.

Table 21. Static Analysis of SPR Crossings with Tractor-Lowboy Trailer Vehicle Models

Wheelbase ft-in. (m)	Track Elevation in. (mm)												
	0	1 (25)	2 (51)	3 (76)	4 (102)	5 (127)	6 (152)	7 (178)	8 (203)	9 (229)	10 (254)	11 (279)	12 (305)
26-0 (7.9)	2.52 (64)	2.95 (75)	3.37 (86)	3.79 (96)	4.21 (107)	4.63 (118)	5.07 (129)	5.47 (139)	5.89 (150)	6.31 (160)	6.73 (171)	7.15 (182)	7.57 (192)
28-0 (8.5)	2.82 (72)	3.30 (84)	3.77 (96)	4.24 (108)	4.71 (120)	5.18 (132)	5.67 (144)	6.12 (155)	6.59 (167)	7.06 (179)	7.53 (191)	8.00 (203)	8.47 (215)
30-0 (9.1)	3.12 (79)	3.65 (93)	4.17 (106)	4.69 (119)	5.21 (132)	5.73 (146)	6.27 (159)	6.77 (172)	7.29 (185)	7.81 (198)	8.33 (212)	8.85 (225)	9.37 (238)
32-0 (9.8)	3.42 (87)	4.00 (101)	4.57 (116)	5.14 (130)	5.71 (145)	6.28 (160)	6.87 (174)	7.42 (188)	7.99 (203)	8.56 (217)	9.13 (232)	9.70 (246)	10.27 (261)
34-0 (10.4)	3.72 (95)	4.35 (110)	4.97 (126)	5.59 (142)	6.21 (158)	6.83 (173)	7.47 (190)	8.07 (205)	8.69 (221)	9.31 (237)	9.93 (252)	10.55 (268)	11.17 (284)
36-0 (11.0)	4.02 (102)	4.70 (119)	5.37 (136)	6.04 (153)	6.71 (170)	7.38 (187)	8.07 (205)	8.72 (221)	9.39 (239)	10.06 (256)	10.37 (263)	11.40 (290)	12.07 (307)
38-0 (11.6)	4.32 (110)	5.05 (128)	5.77 (146)	6.49 (165)	7.21 (183)	7.93 (201)	8.65 (220)	9.37 (238)	10.09 (256)	10.81 (275)	11.53 (293)	12.25 (311)	12.97 (330)
40-0 (12.2)	4.62 (117)	5.40 (137)	6.17 (157)	6.94 (176)	7.71 (196)	8.48 (215)	9.25 (235)	10.02 (255)	10.79 (274)	11.56 (294)	12.33 (313)	13.10 (333)	13.87 (352)
42-0 (12.8)	4.92 (125)	5.75 (146)	6.57 (167)	7.39 (188)	8.21 (208)	9.03 (229)	9.85 (250)	10.67 (271)	11.49 (292)	12.31 (313)	13.13 (334)	13.95 (354)	14.77 (375)

### 8.5.2 Dynamic Tractor with a Lowboy Trailer in TruckSim

TruckSim simulations were performed on thirteen SPR and elevated SPR guideline crossings with seventeen tractor-lowboy vehicle models. The results are shown in Table 22. It was determined that if crossings were constructed to be compliant with SPR guidelines, even low-wheelbase lowboy trailers were likely to contact and potentially become high-centered on the tracks. No configurations were deemed acceptable for any lowboy trailer.

Table 22. SPR Crossings with Tractor-Lowboy Trailer Vehicle Models

Wheelbase ft-in. (m)	Track Elevation in. (mm)												
	0	1 (25)	2 (51)	3 (76)	4 (102)	5 (127)	6 (152)	7 (178)	8 (203)	9 (229)	10 (254)	11 (279)	12 (305)
26-0 (7.9)	Red	Red	Red	Red	Red	Red	Red	Red	Red	Red	Red	Red	Red
28-0 (8.5)	Red	Red	Red	Red	Red	Red	Red	Red	Red	Red	Red	Red	Red
30-0 (9.1)	Red	Red	Red	Red	Red	Red	Red	Red	Red	Red	Red	Red	Red
32-0 (9.8)	Red	Red	Red	Red	Red	Red	Red	Red	Red	Red	Red	Red	Red
34-0 (10.4)	Red	Red	Red	Red	Red	Red	Red	Red	Red	Red	Red	Red	Red
36-0 (11.0)	Red	Red	Red	Red	Red	Red	Red	Red	Red	Red	Red	Red	Red
38-0 (11.6)	Red	Red	Red	Red	Red	Red	Red	Red	Red	Red	Red	Red	Red
40-0 (12.2)	Red	Red	Red	Red	Red	Red	Red	Red	Red	Red	Red	Red	Red
42-0 (12.8)	Red	Red	Red	Red	Red	Red	Red	Red	Red	Red	Red	Red	Red
44-0 (13.4)	Red	Red	Red	Red	Red	Red	Red	Red	Red	Red	Red	Red	Red
46-0 (14.0)	Red	Red	Red	Red	Red	Red	Red	Red	Red	Red	Red	Red	Red
48-0 (14.6)	Red	Red	Red	Red	Red	Red	Red	Red	Red	Red	Red	Red	Red
50-0 (15.2)	Red	Red	Red	Red	Red	Red	Red	Red	Red	Red	Red	Red	Red
53-8 (16.4)	Red	Red	Red	Red	Red	Red	Red	Red	Red	Red	Red	Red	Red
56-2 (17.1)	Red	Red	Red	Red	Red	Red	Red	Red	Red	Red	Red	Red	Red
61-1 (18.6)	Red	Red	Red	Red	Red	Red	Red	Red	Red	Red	Red	Red	Red
61-8 (18.8)	Red	Red	Red	Red	Red	Red	Red	Red	Red	Red	Red	Red	Red

### 8.5.3 Dynamic Bus in TruckSim

TruckSim simulations were performed on thirteen SPR and elevated SPR guideline crossings with nine bus vehicle models. The results are shown in Table 23. No SPR or elevated SPR crossing had the potential to cause any of the bus vehicle models to become high-centered.



Table 23. SPR Crossings with Bus Vehicle Models

Wheelbase ft-in. (m)	Track Elevation in. (mm)												
	0	1 (25)	2 (51)	3 (76)	4 (102)	5 (127)	6 (152)	7 (178)	8 (203)	9 (229)	10 (254)	11 (279)	12 (305)
13-2 (4.0)	Green	Green	Green	Green	Green	Green	Green	Green	Green	Green	Green	Green	Green
17-4 (5.3)	Green	Green	Green	Green	Green	Green	Green	Green	Green	Green	Green	Green	Green
18-4 (5.6)	Green	Green	Green	Green	Green	Green	Green	Green	Green	Green	Green	Green	Green
21-0 (6.4)	Green	Green	Green	Green	Green	Green	Green	Green	Green	Green	Green	Green	Green
23-0 (7.0)	Green	Green	Green	Green	Green	Green	Green	Green	Green	Green	Green	Green	Green
24-1 (7.3)	Green	Green	Green	Green	Green	Green	Green	Green	Green	Green	Green	Green	Green
25-5 (7.7)	Green	Green	Green	Green	Green	Green	Green	Green	Green	Green	Green	Green	Green
26-6 (8.1)	Green	Green	Green	Green	Green	Green	Green	Green	Green	Green	Green	Green	Green
27-10.5 (8.5)	Green	Green	Green	Green	Green	Green	Green	Green	Green	Green	Green	Green	Green

## 8.6 Recommendations

Generally, simulation results using dynamic vehicles suggested a higher percentage of crossing geometries which posed risks to tractor-trailer vehicles than static analyses. Thus, researchers sought to determine why static and dynamic analyses diverged.

A key feature of the dynamic model was the ability to represent dynamic compression and expansion of the vehicle suspension. Thus, as the truck and trailer were traversing the grade crossings, the heights at the fifth wheel attachment, truck rear suspension, trailer wheel suspension, and undercarriage changed based on the truck’s position along the simulated grade crossings. Although simulation suspension deflections were typically limited to less than 2 in. (51 mm) for any configuration simulated, results contributed to a larger trailer and truck pitch angle than was expected. Thus, more configurations were determined to experience contact with the crossing surface than was predicted using the static analysis.

Additionally, only contact was explored in the dynamic analysis. If contact was deemed likely, the crossing was denoted as “at risk,” or red. However, the three surveyed crossings near Bellevue, Nebraska, indicated signs that trailer configurations had indeed contacted the ground –

but aside from scraping, were nonetheless able to proceed without incident or a subsequent crash with a train. Thus, scraping alone does not indicate a trailer will become stuck, but does denote that there is potential for a trailer to become stuck at that location.

Based on the simulation results, a maximum highway-rail grade crossing guideline is recommended and illustrated in Figure 162. The crossing surface should be level with the top of the rails for 2 ft (0.6 m) outside of the rails. For 30 ft (9.1 m) outside of each rail, the surface should not be more than 6 in. (152 mm) lower than the top of the rail. This recommendation corresponds to the AASHTO/AREMA (2015) guideline with 3 in. (76 mm) elevation and the AREMA (1990) guideline with 0 in. elevation.

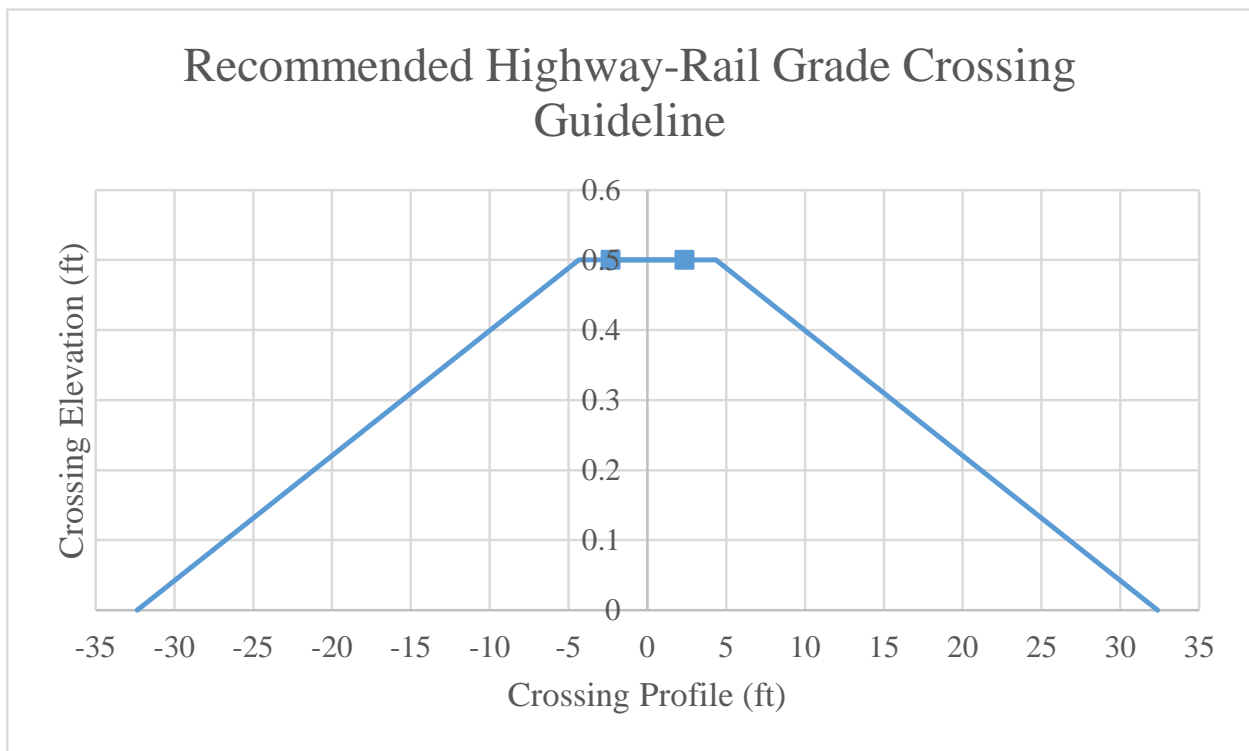

Figure 162. Recommended Highway-Rail Grade Crossing Guideline

This recommendation could be amended to state that for a *minimum* of 30 ft (9.1 m) outside of each rail, the surface should not be more than 6 in. (152 mm) lower than the top of the rail. Any length greater than 30 ft (9.1 m) would result in a less steep approach grade, shown in Figure 163.

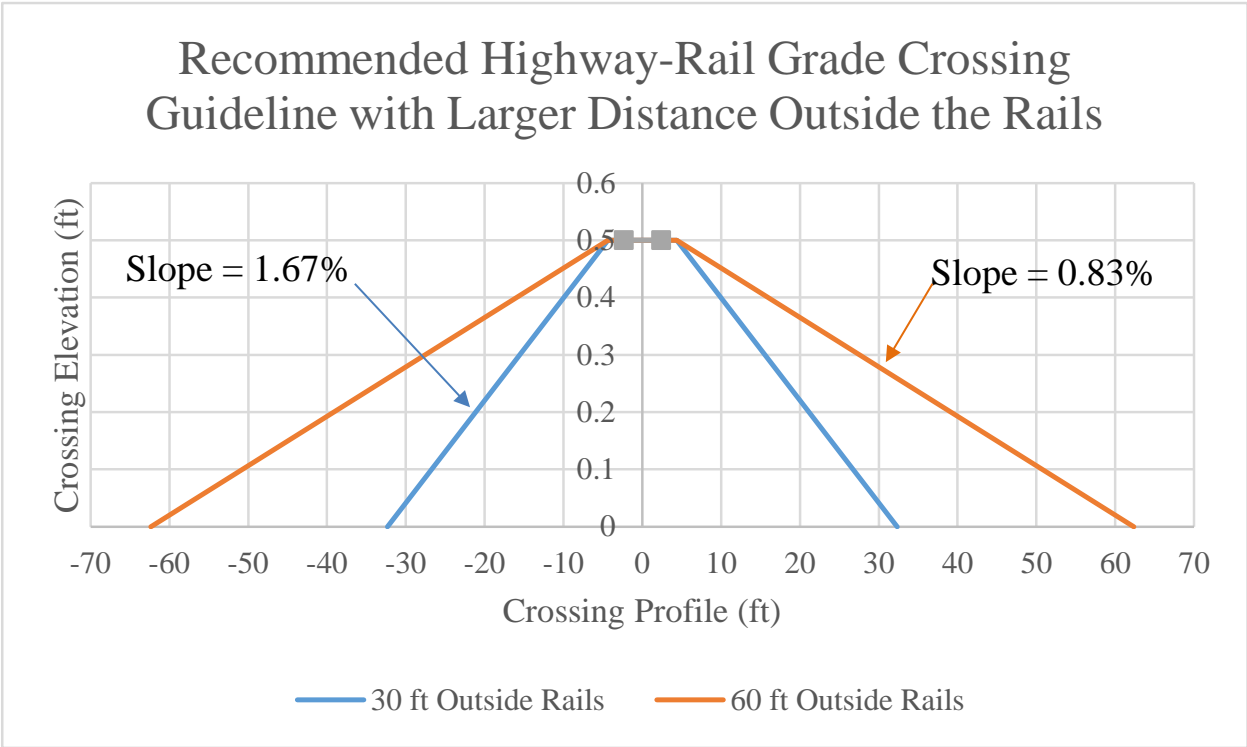

Figure 163. Recommended Highway-Rail Grade Crossing Guideline with Larger Distance Outside of the Rails

## **9 SIMULATIONS OF FIELD-SURVEYED GRADE CROSSINGS**

Researchers applied the same TruckSim model to evaluate dynamic crossing of the three surveyed grade crossing sites near Bellevue, Nebraska. Results of that analysis are discussed in the following sections.

### **9.1 Crossing 817404F Results**

#### **9.1.1 Dynamic Tractor with a Lowboy Trailer in TruckSim**

TruckSim simulations were performed on a model of crossing 817404F, in the original and reversed orientation, with seventeen tractor-lowboy vehicle models. The results are shown in Table 24. For vehicles traversing this crossing from north to south, or the original orientation, wheelbases larger than 38 ft (11.6 m) had potential to contact the tracks or become high-centered, and wheelbases larger than 50 ft (15.2 m) were likely to experience contact and could become high-centered. For vehicles traversing this crossing from south to north, or the reversed orientation, wheelbases larger than 36 ft (11.0 m) exhibited the potential for contact, and wheelbases larger than 50 ft (15.2 m) were likely to contact the tracks and could become high-centered.

Table 24. Crossing 817404F with Tractor-Lowboy Trailer Vehicle Models

Wheelbase ft-in. (m)	Crossing Orientation	
	Original	Reversed
26-0 (7.9)	Green	Green
28-0 (8.5)	Green	Green
30-0 (9.1)	Green	Green
32-0 (9.8)	Green	Green
34-0 (10.4)	Green	Green
36-0 (11.0)	Green	Yellow
38-0 (11.6)	Yellow	Yellow
40-0 (12.2)	Yellow	Yellow
42-0 (12.8)	Yellow	Yellow
44-0 (13.4)	Yellow	Yellow
46-0 (14.0)	Yellow	Yellow
48-0 (14.6)	Yellow	Yellow
50-0 (15.2)	Red	Red
53-8 (16.4)	Red	Red
56-2 (17.1)	Red	Red
61-1 (18.6)	Red	Red
61-8 (18.8)	Red	Red

### 9.1.2 Dynamic Bus in TruckSim

TruckSim simulations were performed on a model of crossing 817404F, in the original and reversed orientation, with nine bus vehicle models. The results are shown in Table 25. Crossing no. 817404F did not have the potential to cause any of the bus vehicle models to become high-centered.

Table 25. Crossing 817404F with Bus Vehicle Models

Wheelbase ft-in. (m)	Crossing Orientation	
	Original	Reversed
13-2 (4.0)	Green	Green
17-4 (5.3)	Green	Green
18-4 (5.6)	Green	Green
21-0 (6.4)	Green	Green
23-0 (7.0)	Green	Green
24-1 (7.3)	Green	Green
25-5 (7.7)	Green	Green
26-6 (8.1)	Green	Green
27-10.5 (8.5)	Green	Green

## 9.2 Crossing 817405M Results

### 9.2.1 Dynamic Tractor with a Lowboy Trailer in TruckSim

TruckSim simulations were performed on a model of crossing 817405M, in the original and reversed orientation, with seventeen tractor-lowboy vehicle models. The results are shown in Table 26. For vehicles traversing this crossing from north to south, or the original orientation, wheelbases larger than 28 ft (8.5 m) could experience trailer undercarriage contact, and for wheelbases larger than 34 ft (10.4 m), contact was likely and trailers could become high-centered. For vehicles traversing this crossing from south to north, or the reversed orientation, contact was possible and warnings were denoted for wheelbases of at least 26 ft (7.9 m), and contact was likely, and could lead to low-ground clearance trailers with wheelbases longer than 32 ft (9.8 m) to become high-centered.



Table 26. Crossing 817405M with Tractor-Lowboy Trailer Vehicle Models

Wheelbase ft-in. (m)	Crossing Orientation	
	Original	Reversed
26-0 (7.9)	Green	Yellow
28-0 (8.5)	Yellow	Yellow
30-0 (9.1)	Yellow	Yellow
32-0 (9.8)	Yellow	Red
34-0 (10.4)	Red	Red
36-0 (11.0)	Red	Red
38-0 (11.6)	Red	Red
40-0 (12.2)	Red	Red
42-0 (12.8)	Red	Red
44-0 (13.4)	Red	Red
46-0 (14.0)	Red	Red
48-0 (14.6)	Red	Red
50-0 (15.2)	Red	Red
53-8 (16.4)	Red	Red
56-2 (17.1)	Red	Red
61-1 (18.6)	Red	Red
61-8 (18.8)	Red	Red

### 9.2.2 Dynamic Bus in TruckSim

TruckSim simulations were performed on a model of crossing 817405M, in the original and reversed orientation, with nine bus vehicle models. The results are shown in Table 27. Results for crossing no. 817405M did not suggest that any of the bus vehicle models would become high-centered.

Table 27. Crossing 817405M with Bus Vehicle Models

Wheelbase ft-in. (m)	Crossing Orientation	
	Original	Reversed
13-2 (4.0)	Green	Green
17-4 (5.3)	Green	Green
18-4 (5.6)	Green	Green
21-0 (6.4)	Green	Green
23-0 (7.0)	Green	Green
24-1 (7.3)	Green	Green
25-5 (7.7)	Green	Green
26-6 (8.1)	Green	Green
27-10.5 (8.5)	Green	Green

### 9.3 Crossing 816134F Results

#### 9.3.1 Dynamic Tractor with a Lowboy Trailer in TruckSim

TruckSim simulations were performed on a model of crossing 816134F, in the original and reversed orientation, with seventeen tractor-lowboy vehicle models. The results are shown in Table 28. For vehicles traversing this crossing from north to south, or the original orientation, warnings were denoted for wheelbases larger than 36 ft (11.0 m) and contact was likely, along with the potential for trailers with for wheelbases of 50 ft (15.2 m) or more to become high-centered. For vehicles traversing this crossing from south to north, or the reversed orientation, trailers with wheelbases longer than 32 ft (9.8 m) could contact the tracks, and contact was deemed likely as well as a higher risk for becoming high-centered for wheelbases larger than 50 ft (15.2 m).

Table 28. Crossing 816134F with Tractor-Lowboy Trailer Vehicle Models

Wheelbase ft-in. (m)	Crossing Orientation	
	Original	Reversed
26-0 (7.9)	Green	Green
28-0 (8.5)	Green	Green
30-0 (9.1)	Green	Green
32-0 (9.8)	Green	Yellow
34-0 (10.4)	Green	Yellow
36-0 (11.0)	Yellow	Yellow
38-0 (11.6)	Yellow	Yellow
40-0 (12.2)	Yellow	Yellow
42-0 (12.8)	Yellow	Yellow
44-0 (13.4)	Yellow	Yellow
46-0 (14.0)	Yellow	Yellow
48-0 (14.6)	Yellow	Yellow
50-0 (15.2)	Red	Red
53-8 (16.4)	Red	Red
56-2 (17.1)	Red	Red
61-1 (18.6)	Red	Red
61-8 (18.8)	Red	Red

### 9.3.2 Dynamic Bus in TruckSim

TruckSim simulations were performed on a model of crossing 816134F, in the original and reversed orientation, with nine bus vehicle models. The results are shown in Table 29. Results suggested that bus vehicle models did not have a high risk of becoming high centered on tracks at crossing no. 816134F.

Table 29. Crossing 816134F with Bus Vehicle Models

Wheelbase ft-in. (m)	Crossing Orientation	
	Original	Reversed
13-2 (4.0)	Green	Green
17-4 (5.3)	Green	Green
18-4 (5.6)	Green	Green
21-0 (6.4)	Green	Green
23-0 (7.0)	Green	Green
24-1 (7.3)	Green	Green
25-5 (7.7)	Green	Green
26-6 (8.1)	Green	Green
27-10.5 (8.5)	Green	Green

#### 9.4 Discussion and Conclusions

Simulations of the real-world grade crossings indicated that some issues may arise if long-wheelbase trailers attempt to cross at the grade crossings. Scraping which was observed at these locations reinforce simulation results that contact is likely (and demonstrably occurred). Results confirm the simulations and reinforce confidence in the recommendations described in Chapter 8.

## **10 SUMMARY, CONCLUSIONS, AND RECOMMENDATIONS**

### **10.1 Summary and Conclusions**

To study highway-rail grade crossing incidents and accidents involving low, long wheelbase vehicles, a literature review was performed. Accidents involving these types of vehicles can be very costly and result in deaths. These accidents can be avoided if highway-rail grade crossings follow appropriate profile elevation guidelines and crossings are maintained to these guidelines. Based on simulations of low, long wheelbase vehicles on various crossing profiles, a highway-rail grade crossing guideline was recommended and is shown in Figure 164.

#### **10.1.1 Field Testing**

Field tests on a speed table were performed to evaluate the effect of vehicle suspension on vehicle sprung mass vertical displacement at speeds between 5 and 15 mph (8.0 and 24.1 km/h) to properly set suspension properties in the simulation program TruckSim. Field tests were performed and vertical displacements were calculated from video analysis and an accelerometer mounted on the vehicle. Test results were used to calibrate and validate simulation properties using both finite element analysis (LS-DYNA) and rigid body analysis (TruckSim).

#### **10.1.2 TL-5 LS-DYNA Modeling**

Test nos. UTCRS-2 and UTCRS-3 were simulated in LS-DYNA modeling software for comparison to the live test results to determine trailer suspension properties. A tractor-trailer vehicle model developed by a research team at ORNL and UTK and modified by Chuck Plaxico of Roadsafe, LLC and John Reid of MwRSF was updated and utilized for the simulations.

Two methods for modeling the speed table, rigidwall planar finite and brick solid element, were simulated and compared to each other as well as to the live speed table test results. It was determined that the rigidwall planar finite and brick solid element methods yielded similar results. It was also determined that the live speed table test vertical displacement results were similar to

the simulation vertical displacement results. Dynamic suspension properties of the trailer model were explored and produced reasonable dynamic behavior.

### **10.1.3 TruckSim Simulations**

TruckSim simulations of the speed table tests were performed and the resulting vertical displacements were calculated. The field and simulation displacements were similar, and therefore the default simulation and internal properties of the truck in TruckSim were used. Vehicles programmed into TruckSim were used to perform simulations, with modified trailer wheelbases.

The program TruckSim was utilized to simulate tractor-lowboys and buses traversing various highway-rail grade crossings. A range of vehicle wheelbases were simulated on crossings to determine which resulted in vehicles that could potentially become high-centered, and from these results, crossing profile guidelines were developed. The dynamic results generated by TruckSim were compared against static results generated from AutoCAD. It was determined that the dynamic simulations produced more accurate results.

The recommended guideline is shown in Figure 164. Using this guideline for a maximum limiting roadway grade crossing configuration will reduce the likelihood of any vehicle becoming high-centered for wheelbases up to 61 ft – 8 in. (18.8 m) and with a ground clearance of 6.5 in. (165 mm). The recommended guideline allows for a 3-in. (76-mm) elevation increase compared to the AASHTO/AREMA (2015) guidelines.

## **10.2 Recommendations**

A maximum crossing profile guideline was recommended in Section 8.6 and is shown in Figure 164. The guideline states, “The crossing surface should be level with the top of the rails for 2 ft (0.6 m) outside of the rails. For a minimum of 30 ft (9.1 m) outside of each rail, the surface should not be more than 6 in. (152 mm) lower than the top of the rail.”



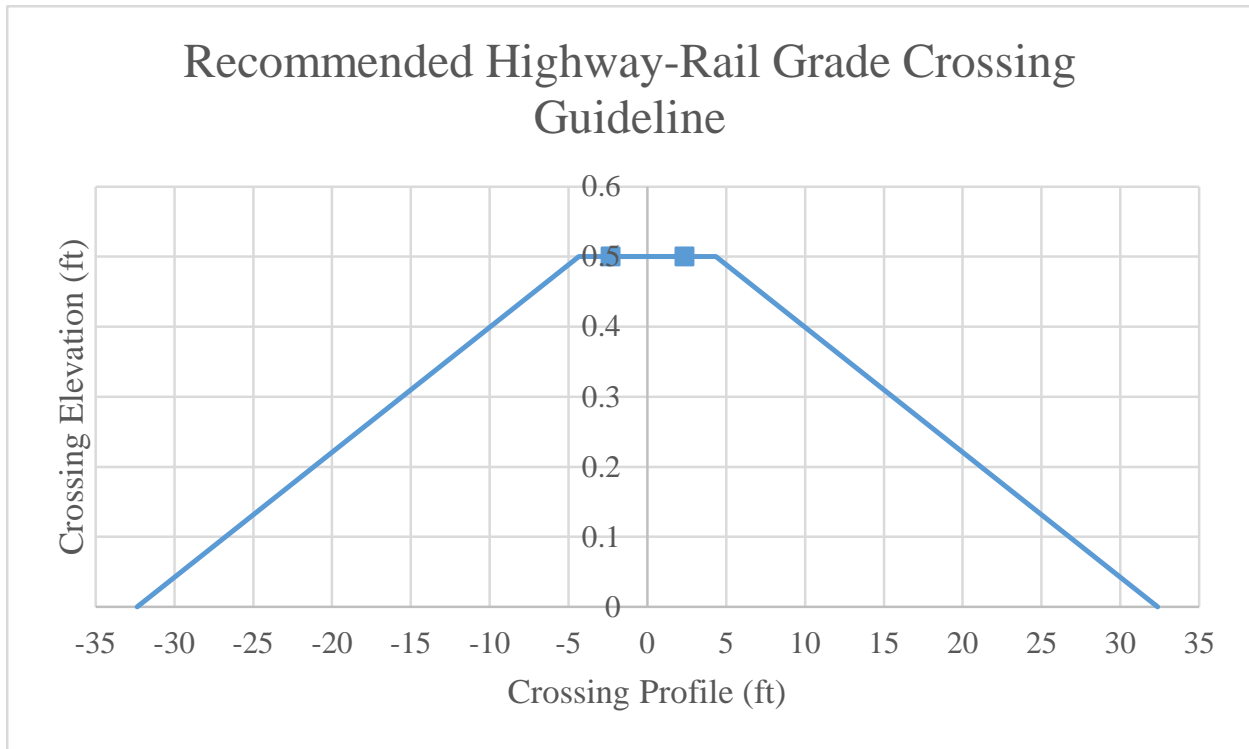

Figure 164. Recommended Highway-Rail Grade Crossing Guideline

No configuration of railway tracks consistent with the SPR guidelines was deemed “green,” or unlikely to experience undercarriage contact or long-wheelbase, low-ground clearance trailers becoming high-centered. Results indicate that SPR guidelines may not be optimal for crossing design.

### 10.3 Future Research

Because the rail grade crossing locations are already known, researchers recommend that railway companies partner with state agencies to develop a new application which denotes the relative traversability of grade crossings, or the functionality of the existing FRA web portal could be extended to identify optimal routes for low-ground clearance trailers. The information could be made available through a phone application or other format, so it could be utilized by drivers and the public to reduce or eliminate large trucks becoming high-centered at grade crossings. This would require crossing profiles to be measured accurately and catalogued. The application could

indicate which vehicle wheelbase would cause the vehicle to become high-centered on a certain crossing. Because maintenance is performed on crossings and can result in altered crossing profiles, this database would have to be updated whenever maintenance is performed on a crossing.

Highway-rail grade crossings across Nebraska were surveyed with Google Earth as part of this research study. While analyzing the crossings with the street view feature, it was noted that many steeper-appearing crossings did not have a low ground clearance warning sign. According to the MUTCD, low ground clearance warning signs should be installed in advance of the grade crossing if the conditions are sufficiently abrupt to create a hang-up situation for long wheelbase vehicles or trailers [9]. It is recommended that signage is updated after construction and maintenance that alters the crossing geometry.

In addition to these signs, listing the vehicle wheelbase that is unsafe to traverse the crossing could be included when a low ground clearance warning sign is placed at a crossing. To determine this, accurate crossing dimensions would need to be collected and simulations would need to be performed. Until more accurate models and configurations could be developed, guidelines described in this study could be used for the initial analysis.

## 11 REFERENCES

1. "Crossing Collisions and Casualties by Year," Operation Lifesaver, Accessed on June 30, 2017, <https://oli.org/about-us/news/collisions-casulties>.
2. Hellman, A., Lopez-Bernal, G., *Highway-Rail Intersection Crash Taxonomy for Connected Vehicle Safety Research*, U.S. Department of Transportation, Federal Railroad Administration, Report no. DOT/FRA/ORD-15/14, May 2015.
3. *Manual for Railway Engineering*, American Railway Engineering and Maintenance-of-Way Association (AREMA), Lanham, Maryland, 2015.
4. Eck, R.W., Kang, S.K., *Low-Clearance Vehicles at Rail-Highway Grade Crossings: An Overview of the Problem and Potential Solutions*, Transportation Research Report Record No. 1327, Transportation Research Board, Washington, D.C., 1991.
5. *Highway/Rail Grade Crossing Collision near Sycamore, South Carolina May 2, 1995*, National Transportation Safety Board (NTSB) Highway Accident Report PB96-916201, Washington, D.C., 1996.
6. "Cleanup continues after train derailment in Louisiana," Associated Press, New Orleans, Published October 6, 2014. <http://www.foxnews.com/us/2014/10/06/2-injured-when-train-derails-in-louisiana.html>.
7. "New York City-Bound Amtrak Train Hits Truck, Derails in North Carolina; 55 Hurt," NBC New York, March 9, 2015, Accessed on June 2, 2017, <https://www.nbcnewyork.com/news/local/New-York-North-Carolina-Amtrak-Train-Derailment-Collision-Injuries-295641841.html>.
8. *A Policy on Geometric Design of Highways and Streets*, Sixth Edition, American Association of State Highway and Transportation Officials (AASHTO), Washington, D.C., 2011.
9. *Manual on Uniform Traffic Control Devices for Streets and Highways*, United States Department of Transportation-Federal Highway Administration (FHWA), Washington, D.C., 2009.
10. *Railroad-Highway Grade Crossing Handbook-Revised Second Edition 2007*, United States Department of Transportation-Federal Highway Administration (FHWA) Report FHWA-SA-07-010, Washington, D.C., 2007.
11. Sobanjo, J.O., *Design Guidelines for Highway Railroad Grade Crossing Profiles in Florida*, Contract No. BC 352-15, Department of Civil and Environmental Engineering, Florida State University, Tallahassee, Florida, May 2006.
12. *A Policy on Geometric Design of Highways and Streets*, Second Edition, American Association of State Highway and Transportation Officials (AASHTO), Washington, D.C., 1990.

13. Jennings, L.S., *Compilation of State Laws and Regulations Affecting Highway-Rail Grade Crossings*, Fifth Edition, United States Department of Transportation-Federal Railroad Administration (FRA), 2009.
14. McConnell, W.A., *Passenger Car Overhang and Underclearance as Related to Driveway Profile Design Part I-Vehicle Data*, Washington, D.C., 1958.
15. Bauer, L.A., *Passenger Car Overhang and Underclearances as Related to Driveway Profile Design Part II-Street and Highway Design*, Washington, D.C., 1958.
16. French, L.J., Eck, R.W., Clawson, A.L., *Development of Design Vehicles and Characteristics for the Hangup Problem*, Department of Civil and Environmental Engineering, West Virginia University, Morgantown, West Virginia, 2002.
17. *A Policy on Geometric Design of Highways and Streets*, Third Edition, American Association of State Highway and Transportation Officials (AASHTO), Washington, D.C., 1994.
18. Mutabazi, M., Russel, E.R., *Identification of Hump Highway/Rail Crossings in Kansas*, Report No. K-TRAN: KSU-99-1, Kansas Department of Transportation (KDOT), Topeka, Kansas, Kansas State University, Manhattan, Kansas, July 2003.
19. *Collision Between Metrolink Train 901 and Mercury Transportation, Inc., Tractor-Combination Vehicle at Highway-Railroad Grade Crossing in Glendale, California January 28, 2000*, National Transportation Safety Board (NTSB) Highway Accident Report PB2001-916202, Washington, D.C., 2001.
20. *Collision of Amtrak Train no. 88 with Rountree Transport and Rigging Vehicle on CSX Transportation, Inc., Railroad Near Intercession City, Florida November 30, 1993*, National Transportation Safety Board (NTSB) Highway Accident Report PB95-91620, Washington, D.C., 1995.
21. National Transportation Safety Board (NTSB), Safety Recommendations H-84-66 through -68, Washington, D.C., 1984.
22. National Transportation Safety Board (NTSB), Railroad Accident Brief ATL-97-FR-004, Washington, D.C., 2001.
23. Paola, J.D., "Train Hits Car Carrier Stuck on Tracks," Sun Sentinel, March 16, 1988, Accessed on March 9, 2017, [http://articles.sun-sentinel.com/1988-03-16/news/8801170006\\_1\\_truck-driver-trailer-train](http://articles.sun-sentinel.com/1988-03-16/news/8801170006_1_truck-driver-trailer-train).
24. Campbell, D., "Train Severs Carhauler Stuck on Tracks," TransportFool, March 23, 2010, Accessed on March 9, 2017, <http://transportfool.com/auto-transport/1107/>.
25. Mihaylov, M., "Car Shipping Adventure-North Carolina to Illinois," Montway Auto Transport, March 28, 2012, Accessed on March 9, 2017, <https://www.montway.com/blog/car-shipping-adventure/>.

26. West, D., "29 Hurt as Commuter Train Hits a Truck in Westchester," The New York Times, September 21, 2004, Accessed on March 17, 2017, [http://www.nytimes.com/2004/09/21/nyregion/29-hurt-as-commuter-train-hits-a-truck-in-westchester.html?\\_r=3](http://www.nytimes.com/2004/09/21/nyregion/29-hurt-as-commuter-train-hits-a-truck-in-westchester.html?_r=3).
27. Guidotti, R., "Train Hits Tractor-Trailer Stuck on Tracks in Springdale Borough," CBS Pittsburg, October 23, 2013, Accessed on March 9, 2017, <http://pittsburgh.cbslocal.com/2013/10/23/train-hits-tractor-trailer-stuck-on-tracks-in-springdale-borough/>.
28. Branca, A., "Car Carrier Gets Stuck on Crossing, Blocks Downtown Rail Track,s, Daily Light, July 22, 2015, Accessed on March 9, 2017, <http://www.waxahachietx.com/article/20150722/News/307229941>.
29. Case, A., "Slow-Moving Train Crashes into Car Carrier South of Downtown Colorado Springs," Fox 21 News, October 4, 2016, Accessed on March 9, 2017, <http://fox21news.com/2016/10/04/slow-moving-train-crashes-into-car-carrier-south-of-downtown-colorado-springs/>.
30. Warren, L., "Minor Repairs being made in Johnston Train Wreck," WRDW 12, May 26, 2015, Accessed on March 9, 2017, <http://www.wrdw.com/home/headlines/DISPATCH-Crews-respond-to-train-wreck-in-Johnston-on-Lee-St-at-Calhoun-St-303747241.html>.
31. "Train Hits Truck in Rayville, No Injuries Reported," KNOE 8 News, May 5, 2016, Accessed on March 9, 2017, <http://www.knoe.com/home/headlines/Train-hits-truck-in-Rayville-no-injuries-reported-378273641.html>.
32. "Train Crashes into Semi Trailer Stuck at Railroad Crossing," WBTV, 2011, Accessed on March 9, 2017, <http://www.wbvtv.com/story/14901728/crash-with-semi-trailer-in-kings-mountain>.
33. "Amtrak Train hits stuck tractor-trailer at Kings Mountain rail crossing," January 4, 2011. <http://www.blueridgenow.com/article/NC/20110104/Lifestyle/606009728/HT/>
34. "Truck ripped in half by train in Kings Mountain," WSOCTV.com, Posted May 4, 2012. <https://www.wsocvtv.com/news/local/truck-ripped-half-train-kings-mountain/329700973>
35. Dyches, C., "Train hits tractor-trailer in Kings Mountain," WBTV.com, 2012. <http://www.wbvtv.com/story/18145277/train-hits-tractor-trailer-in-kings-mountain-2nd-this-week>
36. "Scream and accident – Big Truck Gets Hit by Train," YouTube video, May 6, 2012. [https://www.youtube.com/watch?v=n2EHsERtN0s&has\\_verified=1](https://www.youtube.com/watch?v=n2EHsERtN0s&has_verified=1)
37. National Transportation Safety Board (NTSB), Preliminary Report HWY17MH010, Washington, D.C., 2017.
38. "Biloxi Resident Captures Moment before Fatal Bus Accident," ABC 13 Eyewitness News, March 9, 2017, Accessed on March 21, 2017, <http://abc13.com/news/biloxi-resident-captures-moment-before-bus-crash/1789320/>.

39. Johnson, R., "Main St. was Not on Planned Route for Bus Involved in Train Crash," WLOX, March 9, 2017, Accessed on May 9, 2017, <http://www.wlox.com/story/34711954/ntsb-main-st-was-not-on-planned-route-for-bus-involved-in-train-crash>.
40. Herbert, G., "Photos: Train Crashes into Charter Bus from Austin, Killing 4 in Biloxi on March 7, 2017," Statesman, 2017, Accessed on May 10, 2017, <http://www.statesman.com/news/photos-train-crashes-into-charter-bus-from-austin-killing-biloxi-march-2017/hWocvyr9k9Knp3qFt3uTZM/#17>.
41. Hanna, J., "Vehicles Have Been Trapped at Biloxi Crash Site Before," Cable News Network (CNN), March 9, 2017, Accessed on May 8, 2017, <http://www.cnn.com/2017/03/08/us/biloxi-mississippi-bus-train-crash-site-history/>.
42. "More Warnings Posted at Biloxi Train Crossings," WLOX, March 13, 2017, Accessed on May 9, 2017, <http://www.wlox.com/story/34784266/more-warnings-posted-at-biloxi-train-crossings>.
43. "8.01- Query by Location," Federal Railroad Administration Office of Safety Analysis, Accessed on July 10, 2017, <http://safetydata.fra.dot.gov/OfficeofSafety/publicsite/crossing/XingLocResults.aspx?state=31&countycity=&railroad=&reportinglevel=ALL&radionm=County&street=&xingtype=%&xingstatus=1&xingpos=1>.
44. "5.02- Generate Crossing Inventory and Accident Reports," Federal Railroad Administration Office of Safety Analysis, Accessed on July 3, 2017, <http://safetydata.fra.dot.gov/OfficeofSafety/PublicSite/Crossing/Crossing.aspx>.
45. "Current FRA Forms," Federal Railroad Administration Office of Safety Analysis, Accessed on July 20, 2017, <http://safetydata.fra.dot.gov/OfficeofSafety/publicsite/Forms.aspx>.
46. "5.15- Consolidated Highway Rail Accident Incident," Federal Railroad Administration Office of Safety Analysis, Accessed on July 3, 2017, <http://safetydata.fra.dot.gov/OfficeofSafety/publicsite/Query/ConsolidatedHwyRailIncidents.aspx?r=1>.
47. "GIS FRA Safety Map," United States Department of Transportation Federal Railroad Administration, Accessed on July 14, 2017, <http://fragis.fra.dot.gov/GISFRASafety/>.
48. "Google Maps," Google Map, Accessed on July 14, 2017, <https://www.google.com/maps>.
49. "Google Street View," Google Map, Accessed on July 14, 2017, <https://www.google.com/maps/@41.0658408,-96.3186056,3a,60y,331.87h,90.28t/data=!3m6!1e1!3m4!1sz6J4D1m6HwAtm0S7aVST3w!2e0!7i13312!8i6656>.
50. Roberts, D.P., "The Legal History of Federally Granted Railroad Rights-of-Way and the Myth of Congress "1871 Shift," *University of Colorado Law Review*, Vol 82 No. 1, 2011, 80 p.
51. Baldwin, P., and Flynn, A., *Federal Railway Rights of Way*, CRS Report for Congress, Congressional Research Service, May 3, 2006. <http://congressionalresearch.com/RL32140/document.php>



52. “Uneven load and track twist led to Lewisham freight train derailment,” *Rail Technology Magazine*, February 26, 2018. <http://www.railtechnologymagazine.com/Rail-News/uneven-load-and-track-twist-led-to-lewisham-freight-train-derailment>
53. Aratini, L., Siddiqui, F., and Hsu, S., “Metro says a broken rail likely caused Red Line train carrying 63 to derail,” *The Washington Post*, January 15, 2018. [https://www.washingtonpost.com/news/dr-gridlock/wp/2018/01/15/red-line-train-carrying-at-least-60-passengers-derails-near-farragut-north/?noredirect=on&utm\\_term=.64857fd6239a](https://www.washingtonpost.com/news/dr-gridlock/wp/2018/01/15/red-line-train-carrying-at-least-60-passengers-derails-near-farragut-north/?noredirect=on&utm_term=.64857fd6239a)
54. Vartabedian, R., “Why are so main oil trains crashing? Track problems may be to blame,” *Los Angeles Times*, October 7, 2015. <http://www.latimes.com/nation/la-na-crude-train-safety-20151007-story.html>
55. McGonigal, R., “Ballast: To keep ‘em rolling, it takes plenty of rock,” *Trains*, May 1, 2006. <http://trn.trains.com/railroads/abcs-of-railroading/2006/05/ballast>
56. Uzarski, D., *Introduction to Railroad Track Structural Design*, Presented at the BCR2A’09 Railroad Track Design Including Asphalt Trackbeds Pre-Conference Workshop, Champaign, Illinois, June 2009. [https://web.engr.uky.edu/~jrose/papers/Track%20Design%20Introduction%20\(Uzarski\).pdf](https://web.engr.uky.edu/~jrose/papers/Track%20Design%20Introduction%20(Uzarski).pdf)
57. “Kinds of Railway Sleepers and Their Fixing Methods,” AGICO Group. <http://www.rail-fastener.com/how-to-fix-railway-sleepers.html>
58. *Technical Specifications for Construction of Industrial Tracks*, Union Pacific Railroad, Accessed June 2018. <https://www.up.com/customers/ind-dev/operations/specs/track/index.htm>
59. Hallquist, J.O., *LS-DYNA Keyword User’s Manual*, LS-DYNA R7.1, Livermore Software Technology Corporation, Livermore, California, 2014.
60. Plaxico, C., and Kennedy–Battelle, J., *Enhanced Finite Element Analysis Crash Model of Tractor-Trailers (Phase A)*, Report No. #DTRT06G-0043, 2007.
61. Plaxico, C., and Kennedy–Battelle, J., *Enhanced Finite Element Analysis Crash Model of Tractor-Trailers (Phase C)*, Report No. #DTRT06G-0043, September, 2010.
62. Simunovic, S., Bennett, R., and Zisi., N., *Enhanced Finite Element Analysis Crash Model of Tractor-Trailers: Website and User’s Manual*, Report No. DTRT06G-0043, June, 2009.
63. Plaxico, C., Miele, C., Kennedy–Battelle, J., Simunovic, S., and Zisi., N., *Enhanced Finite Element Analysis Crash Model of Tractor-Trailers (Phase B)*, Report No. #DTRT06G-0043, August, 2009.

## **12 APPENDICES**

## **Appendix A. Inventory Forms**

Inventory forms for crossings 073062Y, 073158N, 083312L, 083410C, 817404F, 817405M, and 816134F are provided in this appendix.

**U. S. DOT CROSSING INVENTORY FORM**

DEPARTMENT OF TRANSPORTATION  
FEDERAL RAILROAD ADMINISTRATION

OMB No. 2130-0017

Instructions for the initial reporting of the following types of new or previously unreported crossings: For public highway-rail grade crossings, complete the entire inventory Form. For private highway-rail grade crossings, complete the Header, Parts I and II, and the Submission Information section. For public pathway grade crossings (including pedestrian station grade crossings), complete the Header, Parts I and II, and the Submission Information section. For Private pathway grade crossings, complete the Header, Parts I and II, and the Submission Information section. For grade-separated highway-rail or pathway crossings (including pedestrian station crossings), complete the Header, Part I, and the Submission Information section. For changes to existing data, complete the Header, Part I Items 1-3, and the Submission Information section, in addition to the updated data fields. Note: For private crossings only, Part I Item 20 and Part III Item 2.K. are required unless otherwise noted. An asterisk \* denotes an optional field.

A. Revision Date (MM/DD/YYYY) 03 / 04 / 2016		B. Reporting Agency <input checked="" type="checkbox"/> Railroad <input type="checkbox"/> Transit <input type="checkbox"/> State <input type="checkbox"/> Other		C. Reason for Update (Select only one) <input checked="" type="checkbox"/> Change in Data <input type="checkbox"/> Re-Open <input type="checkbox"/> New Crossing <input type="checkbox"/> Date Change Only <input type="checkbox"/> Closed <input type="checkbox"/> Change in Primary Operating RR <input type="checkbox"/> No Train Traffic <input type="checkbox"/> Quiet Zone Update <input type="checkbox"/> Admin. Correction			D. DOT Crossing Inventory Number 073062Y
<b>Part I: Location and Classification Information</b>							
1. Primary Operating Railroad BNSF Railway Company [BNSF]			2. State NEBRASKA		3. County SARPY		
4. City / Municipality <input type="checkbox"/> In <input checked="" type="checkbox"/> Near BELLEVUE		5. Street/Road Name & Block Number PRIVATE (Street/Road Name) * (Block Number)			6. Highway Type & No. Not Yet Reported by State		
7. Do Other Railroads Operate a Separate Track at Crossing? <input type="checkbox"/> Yes <input checked="" type="checkbox"/> No If Yes, Specify RR				8. Do Other Railroads Operate Over Your Track at Crossing? <input checked="" type="checkbox"/> Yes <input type="checkbox"/> No If Yes, Specify RR ATK			
9. Railroad Division or Region <input type="checkbox"/> None NEBRASKA		10. Railroad Subdivision or District <input type="checkbox"/> None OMAHA		11. Branch or Line Name <input type="checkbox"/> None OREAPOLS-ASHLND		12. RR Milepost 0005.570 (prefix)   (nnn.nnn)   (suffix)	
13. Line Segment 0137		14. Nearest RR Timetable Station BELLEVUE		15. Parent RR (if applicable) <input checked="" type="checkbox"/> N/A		16. Crossing Owner (if applicable) <input type="checkbox"/> N/A BNSF	
17. Crossing Type <input type="checkbox"/> Public <input checked="" type="checkbox"/> Private	18. Crossing Purpose <input checked="" type="checkbox"/> Highway <input type="checkbox"/> Pathway, Ped. <input type="checkbox"/> Station, Ped.	19. Crossing Position <input checked="" type="checkbox"/> At Grade <input type="checkbox"/> RR Under <input type="checkbox"/> RR Over	20. Public Access (if Private Crossing) <input type="checkbox"/> Yes <input checked="" type="checkbox"/> No	21. Type of Train <input type="checkbox"/> Freight <input checked="" type="checkbox"/> Intercity Passenger <input type="checkbox"/> Commuter <input type="checkbox"/> Transit <input type="checkbox"/> Shared Use Transit <input type="checkbox"/> Tourist/Other		22. Average Passenger Train Count Per Day <input type="checkbox"/> Less Than One Per Day <input checked="" type="checkbox"/> Number Per Day 2	
23. Type of Land Use <input type="checkbox"/> Open Space <input type="checkbox"/> Farm <input type="checkbox"/> Residential <input type="checkbox"/> Commercial <input type="checkbox"/> Industrial <input type="checkbox"/> Institutional <input checked="" type="checkbox"/> Recreational <input type="checkbox"/> RR Yard							
24. Is there an Adjacent Crossing with a Separate Number? <input type="checkbox"/> Yes <input checked="" type="checkbox"/> No If Yes, Provide Crossing Number				25. Quiet Zone (FRA provided) <input checked="" type="checkbox"/> No <input type="checkbox"/> 24 Hr <input type="checkbox"/> Partial <input type="checkbox"/> Chicago Excused Date Established			
26. HSR Corridor ID <input checked="" type="checkbox"/> N/A		27. Latitude in decimal degrees (WGS84 std: nn.nnnnnn) 41.11459300		28. Longitude in decimal degrees (WGS84 std: -nnn.nnnnnn) -095.88929900		29. Lat/Long Source <input type="checkbox"/> Actual <input checked="" type="checkbox"/> Estimated	
30.A. Railroad Use *			31.A. State Use *				
30.B. Railroad Use *			31.B. State Use *				
30.C. Railroad Use *			31.C. State Use *				
30.D. Railroad Use *			31.D. State Use *				
32.A. Narrative (Railroad Use) *			32.B. Narrative (State Use) *				
33. Emergency Notification Telephone No. (posted) 800-832-5452		34. Railroad Contact (Telephone No.) 817-352-1549			35. State Contact (Telephone No.) 402-479-4515		
<b>Part II: Railroad Information</b>							
1. Estimated Number of Daily Train Movements							
1.A. Total Day Thru Trains (6 AM to 6 PM) 23	1.B. Total Night Thru Trains (6 PM to 6 AM) 23	1.C. Total Switching Trains 0	1.D. Total Transit Trains 0	1.E. Check if Less Than One Movement Per Day How many trains per week? <input type="checkbox"/>			
2. Year of Train Count Data (YYYY) 2013		3. Speed of Train at Crossing 3.A. Maximum Timetable Speed (mph) 65 3.B. Typical Speed Range Over Crossing (mph) From 1 to 65					
4. Type and Count of Tracks Main 1 Siding 0 Yard 0 Transit 0 Industry 0							
5. Train Detection (Main Track only) <input type="checkbox"/> Constant Warning Time <input type="checkbox"/> Motion Detection <input type="checkbox"/> AFO <input type="checkbox"/> PTC <input type="checkbox"/> DC <input type="checkbox"/> Other <input checked="" type="checkbox"/> None							
6. Is Track Signaled? <input type="checkbox"/> Yes <input checked="" type="checkbox"/> No			7.A. Event Recorder <input type="checkbox"/> Yes <input type="checkbox"/> No		7.B. Remote Health Monitoring <input type="checkbox"/> Yes <input type="checkbox"/> No		

Figure A-1. Crossing 073062Y Inventory Form – Page 1 [44]

**U. S. DOT CROSSING INVENTORY FORM**

A. Revision Date (MM/DD/YYYY) 03/04/2016		PAGE 2		D. Crossing Inventory Number (7 char.) 073062Y	
<b>Part III: Highway or Pathway Traffic Control Device Information</b>					
1. Are there Signs or Signals? <input type="checkbox"/> Yes <input checked="" type="checkbox"/> No					
2. Types of Passive Traffic Control Devices associated with the Crossing					
2.A. Crossbuck Assemblies (count) 0		2.B. STOP Signs (R1-1) (count) 0	2.C. YIELD Signs (R1-2) (count)	2.D. Advance Warning Signs (Check all that apply; include count) <input type="checkbox"/> None <input type="checkbox"/> W10-1 <input type="checkbox"/> W10-3 <input type="checkbox"/> W10-11 <input type="checkbox"/> W10-2 <input type="checkbox"/> W10-4 <input type="checkbox"/> W10-12	
2.E. Low Ground Clearance Sign (W10-5) <input type="checkbox"/> Yes (count _____) <input type="checkbox"/> No		2.F. Pavement Markings <input type="checkbox"/> Stop Lines <input type="checkbox"/> Dynamic Envelope <input type="checkbox"/> RR Xing Symbols <input type="checkbox"/> None		2.G. Channelization Devices/Medians <input type="checkbox"/> All Approaches <input type="checkbox"/> Median <input type="checkbox"/> One Approach <input type="checkbox"/> None	2.H. EXEMPT Sign (R15-3) <input type="checkbox"/> Yes <input type="checkbox"/> No
2.J. Other MUTCD Signs <input type="checkbox"/> Yes <input checked="" type="checkbox"/> No Specify Type _____ Count _____ Specify Type _____ Count _____ Specify Type _____ Count _____			2.K. Private Crossing Signs (if private) <input type="checkbox"/> Yes <input checked="" type="checkbox"/> No	2.L. LED Enhanced Signs (List types)	
3. Types of Train Activated Warning Devices at the Grade Crossing (specify count of each device for all that apply)					
3.A. Gate Arms (count) Roadway 0 Pedestrian _____		3.B. Gate Configuration <input type="checkbox"/> 2 Quad <input type="checkbox"/> Full (Barrier) <input type="checkbox"/> 3 Quad Resistance <input type="checkbox"/> 4 Quad <input type="checkbox"/> Median Gates		3.C. Cantilevered (or Bridged) Flashing Light Structures (count) Over Traffic Lane 0 <input type="checkbox"/> Incandescent Not Over Traffic Lane 0 <input type="checkbox"/> LED	3.D. Mast Mounted Flashing Lights (count of masts) 0 <input type="checkbox"/> Incandescent <input type="checkbox"/> LED <input type="checkbox"/> Back Lights Included <input type="checkbox"/> Side Lights Included
3.F. Installation Date of Current Active Warning Devices: (MM/YYYY) ____/____/____ <input type="checkbox"/> Not Required		3.G. Wayside Horn <input type="checkbox"/> Yes Installed on (MM/YYYY) ____/____/____ <input type="checkbox"/> No		3.H. Highway Traffic Signals Controlling Crossing <input type="checkbox"/> Yes <input checked="" type="checkbox"/> No	3.I. Bells (count) 0
3.J. Non-Train Active Warning <input type="checkbox"/> Flagging/Flagman <input type="checkbox"/> Manually Operated Signals <input type="checkbox"/> Watchman <input type="checkbox"/> Floodlighting <input type="checkbox"/> None				3.K. Other Flashing Lights or Warning Devices Count 0 Specify type _____	
4.A. Does nearby Hwy Intersection have Traffic Signals? <input type="checkbox"/> Yes <input type="checkbox"/> No		4.B. Hwy Traffic Signal Interconnection <input type="checkbox"/> Not Interconnected <input type="checkbox"/> For Traffic Signals <input type="checkbox"/> For Warning Signs	4.C. Hwy Traffic Signal Preemption <input type="checkbox"/> Simultaneous <input type="checkbox"/> Advance	5. Highway Traffic Pre-Signals <input type="checkbox"/> Yes <input type="checkbox"/> No Storage Distance * _____ Stop Line Distance * _____	6. Highway Monitoring Devices (Check all that apply) <input type="checkbox"/> Yes - Photo/Video Recording <input type="checkbox"/> Yes - Vehicle Presence Detection <input type="checkbox"/> None
<b>Part IV: Physical Characteristics</b>					
1. Traffic Lanes Crossing Railroad Number of Lanes _____		<input type="checkbox"/> One-way Traffic <input type="checkbox"/> Two-way Traffic <input type="checkbox"/> Divided Traffic	2. Is Roadway/Pathway Paved? <input type="checkbox"/> Yes <input type="checkbox"/> No	3. Does Track Run Down a Street? <input type="checkbox"/> Yes <input type="checkbox"/> No	4. Is Crossing Illuminated? (Street lights within approx. 50 feet from nearest rail) <input type="checkbox"/> Yes <input type="checkbox"/> No
5. Crossing Surface (on Main Track, multiple types allowed) Installation Date * (MM/YYYY) ____/____/____ Width * _____ Length * _____ <input type="checkbox"/> 1 Timber <input type="checkbox"/> 2 Asphalt <input type="checkbox"/> 3 Asphalt and Timber <input checked="" type="checkbox"/> 4 Concrete <input type="checkbox"/> 5 Concrete and Rubber <input type="checkbox"/> 6 Rubber <input type="checkbox"/> 7 Metal <input type="checkbox"/> 8 Unconsolidated <input type="checkbox"/> 9 Composite <input type="checkbox"/> 10 Other (specify) _____					
6. Intersecting Roadway within 500 feet? <input type="checkbox"/> Yes <input checked="" type="checkbox"/> No If Yes, Approximate Distance (feet) _____			7. Smallest Crossing Angle <input checked="" type="checkbox"/> 0° - 29° <input type="checkbox"/> 30° - 59° <input type="checkbox"/> 60° - 90°		8. Is Commercial Power Available? * <input type="checkbox"/> Yes <input type="checkbox"/> No
<b>Part V: Public Highway Information</b>					
1. Highway System <input type="checkbox"/> (01) Interstate Highway System <input type="checkbox"/> (02) Other Nat Hwy System (NHS) <input type="checkbox"/> (03) Federal AID, Not NHS <input checked="" type="checkbox"/> (08) Non-Federal Aid		2. Functional Classification of Road at Crossing <input type="checkbox"/> (0) Rural <input type="checkbox"/> (1) Urban <input type="checkbox"/> (1) Interstate <input type="checkbox"/> (5) Major Collector <input type="checkbox"/> (2) Other Freeways and Expressways <input type="checkbox"/> (3) Other Principal Arterial <input type="checkbox"/> (6) Minor Collector <input type="checkbox"/> (4) Minor Arterial <input type="checkbox"/> (7) Local		3. Is Crossing on State Highway System? <input type="checkbox"/> Yes <input type="checkbox"/> No	4. Highway Speed Limit _____ MPH <input type="checkbox"/> Posted <input type="checkbox"/> Statutory
7. Annual Average Daily Traffic (AADT) Year 1970 AADT _____		8. Estimated Percent Trucks 00 %	9. Regularly Used by School Buses? <input type="checkbox"/> Yes <input checked="" type="checkbox"/> No Average Number per Day 0		10. Emergency Services Route <input type="checkbox"/> Yes <input type="checkbox"/> No
<b>Submission Information - This information is used for administrative purposes and is not available on the public website.</b>					
Submitted by _____ Organization _____ Phone _____ Date _____					
Public reporting burden for this information collection is estimated to average 30 minutes per response, including the time for reviewing instructions, searching existing data sources, gathering and maintaining the data needed and completing and reviewing the collection of information. According to the Paperwork Reduction Act of 1995, a federal agency may not conduct or sponsor, and a person is not required to, nor shall a person be subject to a penalty for failure to comply with, a collection of information unless it displays a currently valid OMB control number. The valid OMB control number for information collection is 2130-0017. Send comments regarding this burden estimate or any other aspect of this collection, including for reducing this burden to: Information Collection Officer, Federal Railroad Administration, 1200 New Jersey Ave. SE, MS-25 Washington, DC 20590.					

Figure A-2. Crossing 073062Y Inventory Form – Page 2 [44]

**U. S. DOT CROSSING INVENTORY FORM**

DEPARTMENT OF TRANSPORTATION  
FEDERAL RAILROAD ADMINISTRATION

OMB No. 2130-0017

Instructions for the initial reporting of the following types of new or previously unreported crossings: For public highway-rail grade crossings, complete the entire inventory Form. For private highway-rail grade crossings, complete the Header, Parts I and II, and the Submission Information section. For public pathway grade crossings (including pedestrian station grade crossings), complete the Header, Parts I and II, and the Submission Information section. For Private pathway grade crossings, complete the Header, Parts I and II, and the Submission Information section. For grade-separated highway-rail or pathway crossings (including pedestrian station crossings), complete the Header, Part I, and the Submission Information section. For changes to existing data, complete the Header, Part I Items 1-3, and the Submission Information section, in addition to the updated data fields. Note: For private crossings only, Part I Item 20 and Part III Item 2.K. are required unless otherwise noted. An asterisk \* denotes an optional field.

<b>A. Revision Date</b> (MM/DD/YYYY) 03 / 04 / 2016		<b>B. Reporting Agency</b> <input checked="" type="checkbox"/> Railroad <input type="checkbox"/> Transit <input type="checkbox"/> State <input type="checkbox"/> Other		<b>C. Reason for Update (Select only one)</b> <input checked="" type="checkbox"/> Change in Data <input type="checkbox"/> Re-Open <input type="checkbox"/> New Crossing <input type="checkbox"/> Date Change Only <input type="checkbox"/> Closed <input type="checkbox"/> Change in Primary Operating RR <input type="checkbox"/> No Train Traffic <input type="checkbox"/> Quiet Zone Update <input type="checkbox"/> Admin. Correction			<b>D. DOT Crossing Inventory Number</b> 073158N
<b>Part I: Location and Classification Information</b>							
<b>1. Primary Operating Railroad</b> BNSF Railway Company [BNSF]			<b>2. State</b> NEBRASKA		<b>3. County</b> SARPY		
<b>4. City / Municipality</b> <input type="checkbox"/> In <input checked="" type="checkbox"/> Near ASHLAND		<b>5. Street/Road Name &amp; Block Number</b> 255TH ST (Street/Road Name) * (Block Number)			<b>6. Highway Type &amp; No.</b> Not Yet Reported by State		
<b>7. Do Other Railroads Operate a Separate Track at Crossing?</b> <input type="checkbox"/> Yes <input checked="" type="checkbox"/> No If Yes, Specify RR				<b>8. Do Other Railroads Operate Over Your Track at Crossing?</b> <input checked="" type="checkbox"/> Yes <input type="checkbox"/> No If Yes, Specify RR ATK			
<b>9. Railroad Division or Region</b> <input type="checkbox"/> None NEBRASKA		<b>10. Railroad Subdivision or District</b> <input type="checkbox"/> None OMAHA		<b>11. Branch or Line Name</b> <input type="checkbox"/> None OREAPOLS-ASHLND		<b>12. RR Milepost</b> 0044.320 (prefix)   (nnnn.nnn)   (suffix)	
<b>13. Line Segment</b> 0137		<b>14. Nearest RR Timetable Station</b> ASHLAND		<b>15. Parent RR (if applicable)</b> <input checked="" type="checkbox"/> N/A		<b>16. Crossing Owner (if applicable)</b> <input type="checkbox"/> N/A BNSF	
<b>17. Crossing Type</b> <input checked="" type="checkbox"/> Public <input type="checkbox"/> Private		<b>18. Crossing Purpose</b> <input checked="" type="checkbox"/> Highway <input type="checkbox"/> Pathway, Ped. <input type="checkbox"/> Station, Ped.		<b>19. Crossing Position</b> <input checked="" type="checkbox"/> At Grade <input type="checkbox"/> RR Under <input type="checkbox"/> RR Over		<b>20. Public Access (if Private Crossing)</b> <input type="checkbox"/> Yes <input checked="" type="checkbox"/> No	
<b>21. Type of Train</b> <input type="checkbox"/> Freight <input checked="" type="checkbox"/> Intercity Passenger <input type="checkbox"/> Commuter		<input type="checkbox"/> Transit <input type="checkbox"/> Shared Use Transit <input type="checkbox"/> Tourist/Other		<b>22. Average Passenger Train Count Per Day</b> <input type="checkbox"/> Less Than One Per Day <input checked="" type="checkbox"/> Number Per Day 2			
<b>23. Type of Land Use</b> <input checked="" type="checkbox"/> Open Space <input type="checkbox"/> Farm <input type="checkbox"/> Residential <input type="checkbox"/> Commercial <input type="checkbox"/> Industrial <input type="checkbox"/> Institutional <input type="checkbox"/> Recreational <input type="checkbox"/> RR Yard							
<b>24. Is there an Adjacent Crossing with a Separate Number?</b> <input type="checkbox"/> Yes <input checked="" type="checkbox"/> No If Yes, Provide Crossing Number				<b>25. Quiet Zone (FRA provided)</b> <input checked="" type="checkbox"/> No <input type="checkbox"/> 24 Hr <input type="checkbox"/> Partial <input type="checkbox"/> Chicago Excused Date Established			
<b>26. HSR Corridor ID</b> <input checked="" type="checkbox"/> N/A		<b>27. Latitude in decimal degrees</b> (WGS84 std: nn.nnnnnn) 41.0660800		<b>28. Longitude in decimal degrees</b> (WGS84 std: -nnn.nnnnnn) -96.3187000		<b>29. Lat/Long Source</b> <input type="checkbox"/> Actual <input checked="" type="checkbox"/> Estimated	
<b>30.A. Railroad Use *</b>			<b>31.A. State Use *</b>				
<b>30.B. Railroad Use *</b>			<b>31.B. State Use *</b>				
<b>30.C. Railroad Use *</b>			<b>31.C. State Use *</b>				
<b>30.D. Railroad Use *</b>			<b>31.D. State Use *</b>				
<b>32.A. Narrative (Railroad Use) *</b>			<b>32.B. Narrative (State Use) *</b>				
<b>33. Emergency Notification Telephone No. (posted)</b> 800-832-5452		<b>34. Railroad Contact (Telephone No.)</b> 817-352-1549			<b>35. State Contact (Telephone No.)</b> 402-479-4515		
<b>Part II: Railroad Information</b>							
<b>1. Estimated Number of Daily Train Movements</b>							
<b>1.A. Total Day Thru Trains (6 AM to 6 PM)</b> 21		<b>1.B. Total Night Thru Trains (6 PM to 6 AM)</b> 21		<b>1.C. Total Switching Trains</b> 0	<b>1.D. Total Transit Trains</b> 0	<b>1.E. Check if Less Than One Movement Per Day</b> <input type="checkbox"/> How many trains per week? _____	
<b>2. Year of Train Count Data (YYYY)</b> 2013			<b>3. Speed of Train at Crossing</b> 3.A. Maximum Timetable Speed (mph) 79 3.B. Typical Speed Range Over Crossing (mph) From 1 to 79				
<b>4. Type and Count of Tracks</b> Main 1 Siding 0 Yard 0 Transit 0 Industry 0							
<b>5. Train Detection (Main Track only)</b> <input checked="" type="checkbox"/> Constant Warning Time <input type="checkbox"/> Motion Detection <input type="checkbox"/> AFO <input type="checkbox"/> PTC <input type="checkbox"/> DC <input type="checkbox"/> Other <input type="checkbox"/> None							
<b>6. Is Track Signaled?</b> <input checked="" type="checkbox"/> Yes <input type="checkbox"/> No			<b>7.A. Event Recorder</b> <input type="checkbox"/> Yes <input type="checkbox"/> No		<b>7.B. Remote Health Monitoring</b> <input type="checkbox"/> Yes <input type="checkbox"/> No		

Figure A-3. Crossing 073158N Inventory Form – Page 1 [44]



**U. S. DOT CROSSING INVENTORY FORM**

A. Revision Date (MM/DD/YYYY) 03/04/2016		PAGE 2		D. Crossing Inventory Number (7 char.) 073158N	
<b>Part III: Highway or Pathway Traffic Control Device Information</b>					
1. Are there Signs or Signals? <input checked="" type="checkbox"/> Yes <input type="checkbox"/> No		2. Types of Passive Traffic Control Devices associated with the Crossing			
2.A. Crossbuck Assemblies (count) 0		2.B. STOP Signs (R1-1) (count) 0	2.C. YIELD Signs (R1-2) (count)	2.D. Advance Warning Signs (Check all that apply; include count) <input type="checkbox"/> None <input type="checkbox"/> W10-1 <input type="checkbox"/> W10-3 <input type="checkbox"/> W10-11 <input type="checkbox"/> W10-2 <input type="checkbox"/> W10-4 <input type="checkbox"/> W10-12	
2.E. Low Ground Clearance Sign (W10-5) <input type="checkbox"/> Yes (count _____) <input type="checkbox"/> No		2.F. Pavement Markings <input type="checkbox"/> Stop Lines <input type="checkbox"/> Dynamic Envelope <input type="checkbox"/> RR Xing Symbols <input checked="" type="checkbox"/> None		2.G. Channelization Devices/Medians <input type="checkbox"/> All Approaches <input type="checkbox"/> Median <input type="checkbox"/> One Approach <input type="checkbox"/> None	2.H. EXEMPT Sign (R15-3) <input type="checkbox"/> Yes <input type="checkbox"/> No
2.I. ENS Sign (I-13) Displayed <input type="checkbox"/> Yes <input type="checkbox"/> No		2.J. Other MUTCD Signs <input type="checkbox"/> Yes <input checked="" type="checkbox"/> No Specify Type _____ Count _____ Specify Type _____ Count _____ Specify Type _____ Count _____		2.K. Private Crossing Signs (if private) <input type="checkbox"/> Yes <input type="checkbox"/> No	
2.L. LED Enhanced Signs (List types)					
<b>3. Types of Train Activated Warning Devices at the Grade Crossing (specify count of each device for all that apply)</b>					
3.A. Gate Arms (count) Roadway <u>2</u> Pedestrian _____		3.B. Gate Configuration <input type="checkbox"/> 2 Quad <input type="checkbox"/> Full (Barrier) <input type="checkbox"/> 3 Quad Resistance <input type="checkbox"/> 4 Quad <input type="checkbox"/> Median Gates	3.C. Cantilevered (or Bridged) Flashing Light Structures (count) Over Traffic Lane <u>0</u> <input type="checkbox"/> Incandescent Not Over Traffic Lane <u>0</u> <input type="checkbox"/> LED		3.D. Mast Mounted Flashing Lights (count of masts) <u>2</u> <input type="checkbox"/> Incandescent <input type="checkbox"/> LED <input type="checkbox"/> Back Lights Included <input type="checkbox"/> Side Lights Included
3.E. Total Count of Flashing Light Pairs <u>2</u>		3.F. Installation Date of Current Active Warning Devices: (MM/YYYY) ____/____/____ <input type="checkbox"/> Not Required		3.G. Wayside Horn <input type="checkbox"/> Yes Installed on (MM/YYYY) ____/____/____ <input type="checkbox"/> No	3.H. Highway Traffic Signals Controlling Crossing <input type="checkbox"/> Yes <input checked="" type="checkbox"/> No
3.I. Bells (count) <u>1</u>		3.J. Non-Train Active Warning <input type="checkbox"/> Flagger/Flagman <input type="checkbox"/> Manually Operated Signals <input type="checkbox"/> Watchman <input type="checkbox"/> Floodlighting <input type="checkbox"/> None		3.K. Other Flashing Lights or Warning Devices Count <u>0</u> Specify type _____	
4.A. Does nearby Hwy Intersection have Traffic Signals? <input type="checkbox"/> Yes <input type="checkbox"/> No		4.B. Hwy Traffic Signal Interconnection <input type="checkbox"/> Not Interconnected <input type="checkbox"/> For Traffic Signals <input type="checkbox"/> For Warning Signs	4.C. Hwy Traffic Signal Preemption <input type="checkbox"/> Simultaneous <input type="checkbox"/> Advance	5. Highway Traffic Pre-Signals <input type="checkbox"/> Yes <input type="checkbox"/> No Storage Distance * _____ Stop Line Distance * _____	6. Highway Monitoring Devices (Check all that apply) <input type="checkbox"/> Yes - Photo/Video Recording <input type="checkbox"/> Yes - Vehicle Presence Detection <input type="checkbox"/> None
<b>Part IV: Physical Characteristics</b>					
1. Traffic Lanes Crossing Railroad Number of Lanes <u>2</u> <input type="checkbox"/> One-way Traffic <input type="checkbox"/> Two-way Traffic <input type="checkbox"/> Divided Traffic		2. Is Roadway/Pathway Paved? <input type="checkbox"/> Yes <input checked="" type="checkbox"/> No	3. Does Track Run Down a Street? <input type="checkbox"/> Yes <input checked="" type="checkbox"/> No	4. Is Crossing Illuminated? (Street lights within approx. 50 feet from nearest rail) <input type="checkbox"/> Yes <input type="checkbox"/> No	
5. Crossing Surface (on Main Track, multiple types allowed) Installation Date * (MM/YYYY) ____/____/____ Width * _____ Length * _____ <input checked="" type="checkbox"/> 1 Timber <input type="checkbox"/> 2 Asphalt <input type="checkbox"/> 3 Asphalt and Timber <input type="checkbox"/> 4 Concrete <input type="checkbox"/> 5 Concrete and Rubber <input type="checkbox"/> 6 Rubber <input type="checkbox"/> 7 Metal <input type="checkbox"/> 8 Unconsolidated <input type="checkbox"/> 9 Composite <input type="checkbox"/> 10 Other (specify) _____					
6. Intersecting Roadway within 500 feet? <input checked="" type="checkbox"/> Yes <input type="checkbox"/> No If Yes, Approximate Distance (feet) <u>75</u>		7. Smallest Crossing Angle <input type="checkbox"/> 0° - 29° <input type="checkbox"/> 30° - 59° <input checked="" type="checkbox"/> 60° - 90°		8. Is Commercial Power Available? * <input checked="" type="checkbox"/> Yes <input type="checkbox"/> No	
<b>Part V: Public Highway Information</b>					
1. Highway System <input type="checkbox"/> (01) Interstate Highway System <input type="checkbox"/> (02) Other Nat Hwy System (NHS) <input type="checkbox"/> (03) Federal AID, Not NHS <input checked="" type="checkbox"/> (08) Non-Federal Aid		2. Functional Classification of Road at Crossing <input checked="" type="checkbox"/> (0) Rural <input type="checkbox"/> (1) Urban <input type="checkbox"/> (1) Interstate <input type="checkbox"/> (5) Major Collector <input type="checkbox"/> (2) Other Freeways and Expressways <input type="checkbox"/> (3) Other Principal Arterial <input type="checkbox"/> (6) Minor Collector <input type="checkbox"/> (4) Minor Arterial <input checked="" type="checkbox"/> (7) Local		3. Is Crossing on State Highway System? <input type="checkbox"/> Yes <input checked="" type="checkbox"/> No	4. Highway Speed Limit <u>50</u> MPH <input checked="" type="checkbox"/> Posted <input type="checkbox"/> Statutory
7. Annual Average Daily Traffic (AADT) Year <u>1993</u> AADT <u>000235</u>		8. Estimated Percent Trucks <u>09</u> %	9. Regularly Used by School Buses? <input type="checkbox"/> Yes <input checked="" type="checkbox"/> No Average Number per Day <u>0</u>		10. Emergency Services Route <input type="checkbox"/> Yes <input type="checkbox"/> No
<b>Submission Information - This information is used for administrative purposes and is not available on the public website.</b>					
Submitted by _____ Organization _____ Phone _____ Date _____					
Public reporting burden for this information collection is estimated to average 30 minutes per response, including the time for reviewing instructions, searching existing data sources, gathering and maintaining the data needed and completing and reviewing the collection of information. According to the Paperwork Reduction Act of 1995, a federal agency may not conduct or sponsor, and a person is not required to, nor shall a person be subject to a penalty for failure to comply with, a collection of information unless it displays a currently valid OMB control number. The valid OMB control number for information collection is 2130-0017. Send comments regarding this burden estimate or any other aspect of this collection, including for reducing this burden to: Information Collection Officer, Federal Railroad Administration, 1200 New Jersey Ave. SE, MS-25 Washington, DC 20590.					

Figure A-4. Crossing 073158N Inventory Form – Page 2 [44]

**U. S. DOT CROSSING INVENTORY FORM**

DEPARTMENT OF TRANSPORTATION  
FEDERAL RAILROAD ADMINISTRATION

OMB No. 2130-0017

Instructions for the initial reporting of the following types of new or previously unreported crossings: For public highway-rail grade crossings, complete the entire inventory Form. For private highway-rail grade crossings, complete the Header, Parts I and II, and the Submission Information section. For public pathway grade crossings (including pedestrian station grade crossings), complete the Header, Parts I and II, and the Submission Information section. For Private pathway grade crossings, complete the Header, Parts I and II, and the Submission Information section. For grade-separated highway-rail or pathway crossings (including pedestrian station crossings), complete the Header, Part I, and the Submission Information section. For changes to existing data, complete the Header, Part I Items 1-3, and the Submission Information section, in addition to the updated data fields. Note: For private crossings only, Part I Item 20 and Part III Item 2.K. are required unless otherwise noted. An asterisk \* denotes an optional field.

<b>A. Revision Date</b> (MM/DD/YYYY) 03 / 04 / 2016	<b>B. Reporting Agency</b> <input checked="" type="checkbox"/> Railroad <input type="checkbox"/> Transit <input type="checkbox"/> State <input type="checkbox"/> Other	<b>C. Reason for Update (Select only one)</b> <input checked="" type="checkbox"/> Change in Data <input type="checkbox"/> Re-Open <input type="checkbox"/> New Crossing <input type="checkbox"/> Date Change Only <input type="checkbox"/> Closed <input type="checkbox"/> Change in Primary Operating RR <input type="checkbox"/> No Train Traffic <input type="checkbox"/> Quiet Zone Update <input type="checkbox"/> Admin. Correction	<b>D. DOT Crossing Inventory Number</b> 083312L
---	--	--	--

**Part I: Location and Classification Information**

<b>1. Primary Operating Railroad</b> BNSF Railway Company [BNSF]		<b>2. State</b> NEBRASKA		<b>3. County</b> JOHNSON	
<b>4. City / Municipality</b> <input type="checkbox"/> In <input checked="" type="checkbox"/> Near TECUMSEH		<b>5. Street/Road Name &amp; Block Number</b> 3RD STREET (Street/Road Name) * (Block Number)		<b>6. Highway Type &amp; No.</b> Not Yet Reported by State	
<b>7. Do Other Railroads Operate a Separate Track at Crossing?</b> <input type="checkbox"/> Yes <input checked="" type="checkbox"/> No If Yes, Specify RR			<b>8. Do Other Railroads Operate Over Your Track at Crossing?</b> <input type="checkbox"/> Yes <input checked="" type="checkbox"/> No If Yes, Specify RR		
<b>9. Railroad Division or Region</b> <input type="checkbox"/> None NEBRASKA		<b>10. Railroad Subdivision or District</b> <input type="checkbox"/> None ST JOSEPH		<b>11. Branch or Line Name</b> <input type="checkbox"/> None KC-CARLING	
<b>12. RR Milepost</b> 0166.900 (prefix)   (nnnn.nnn)   (suffix)		<b>13. Line Segment</b> * 3000			
<b>14. Nearest RR Timetable Station</b> * WEST ANABEL		<b>15. Parent RR (if applicable)</b> <input checked="" type="checkbox"/> N/A		<b>16. Crossing Owner (if applicable)</b> <input type="checkbox"/> N/A BNSF	
<b>17. Crossing Type</b> <input checked="" type="checkbox"/> Public <input type="checkbox"/> Private	<b>18. Crossing Purpose</b> <input checked="" type="checkbox"/> Highway <input type="checkbox"/> Pathway, Ped. <input type="checkbox"/> Station, Ped.	<b>19. Crossing Position</b> <input checked="" type="checkbox"/> At Grade <input type="checkbox"/> RR Under <input type="checkbox"/> RR Over	<b>20. Public Access (if Private Crossing)</b> <input type="checkbox"/> Yes <input checked="" type="checkbox"/> No	<b>21. Type of Train</b> <input checked="" type="checkbox"/> Freight <input type="checkbox"/> Intercity Passenger <input type="checkbox"/> Commuter <input type="checkbox"/> Transit <input type="checkbox"/> Shared Use Transit <input type="checkbox"/> Tourist/Other	<b>22. Average Passenger Train Count Per Day</b> <input type="checkbox"/> Less Than One Per Day <input type="checkbox"/> Number Per Day 0
<b>23. Type of Land Use</b> <input type="checkbox"/> Open Space <input type="checkbox"/> Farm <input type="checkbox"/> Residential <input checked="" type="checkbox"/> Commercial <input type="checkbox"/> Industrial <input type="checkbox"/> Institutional <input type="checkbox"/> Recreational <input type="checkbox"/> RR Yard					
<b>24. Is there an Adjacent Crossing with a Separate Number?</b> <input type="checkbox"/> Yes <input checked="" type="checkbox"/> No If Yes, Provide Crossing Number			<b>25. Quiet Zone (FRA provided)</b> <input checked="" type="checkbox"/> No <input type="checkbox"/> 24 Hr <input type="checkbox"/> Partial <input type="checkbox"/> Chicago Excused Date Established		
<b>26. HSR Corridor ID</b> <input checked="" type="checkbox"/> N/A		<b>27. Latitude in decimal degrees</b> (WGS84 std: nn.nnnnnn) 40.4236130		<b>28. Longitude in decimal degrees</b> (WGS84 std: -nnn.nnnnnn) -96.2900630	
<b>29. Lat/Long Source</b> <input type="checkbox"/> Actual <input checked="" type="checkbox"/> Estimated					
<b>30.A. Railroad Use *</b>			<b>31.A. State Use *</b>		
<b>30.B. Railroad Use *</b>			<b>31.B. State Use *</b>		
<b>30.C. Railroad Use *</b>			<b>31.C. State Use *</b>		
<b>30.D. Railroad Use *</b>			<b>31.D. State Use *</b>		
<b>32.A. Narrative (Railroad Use) *</b>			<b>32.B. Narrative (State Use) *</b>		
<b>33. Emergency Notification Telephone No. (posted)</b> 800-832-5452		<b>34. Railroad Contact (Telephone No.)</b> 817-352-1549		<b>35. State Contact (Telephone No.)</b> 402-479-4515	

**Part II: Railroad Information**

<b>1. Estimated Number of Daily Train Movements</b>				
<b>1.A. Total Day Thru Trains (6 AM to 6 PM)</b> 22	<b>1.B. Total Night Thru Trains (6 PM to 6 AM)</b> 22	<b>1.C. Total Switching Trains</b> 0	<b>1.D. Total Transit Trains</b> 0	<b>1.E. Check if Less Than One Movement Per Day</b> <input type="checkbox"/> How many trains per week? _____
<b>2. Year of Train Count Data (YYYY)</b> 2013		<b>3. Speed of Train at Crossing</b> 3.A. Maximum Timetable Speed (mph) 50 3.B. Typical Speed Range Over Crossing (mph) From 1 to 50		
<b>4. Type and Count of Tracks</b> Main 1 Siding 0 Yard 0 Transit 0 Industry 0				
<b>5. Train Detection (Main Track only)</b> <input type="checkbox"/> Constant Warning Time <input checked="" type="checkbox"/> Motion Detection <input type="checkbox"/> AFO <input type="checkbox"/> PTC <input type="checkbox"/> DC <input type="checkbox"/> Other <input type="checkbox"/> None				
<b>6. Is Track Signaled?</b> <input checked="" type="checkbox"/> Yes <input type="checkbox"/> No		<b>7.A. Event Recorder</b> <input type="checkbox"/> Yes <input type="checkbox"/> No		<b>7.B. Remote Health Monitoring</b> <input type="checkbox"/> Yes <input type="checkbox"/> No

Figure A-5. Crossing 083312L Inventory Form – Page 1 [44]

**U. S. DOT CROSSING INVENTORY FORM**

A. Revision Date (MM/DD/YYYY) 03/04/2016		PAGE 2		D. Crossing Inventory Number (7 char.) 083312L	
<b>Part III: Highway or Pathway Traffic Control Device Information</b>					
1. Are there Signs or Signals? <input checked="" type="checkbox"/> Yes <input type="checkbox"/> No		2. Types of Passive Traffic Control Devices associated with the Crossing			
2.A. Crossbuck Assemblies (count) 0		2.B. STOP Signs (R1-1) (count) 0	2.C. YIELD Signs (R1-2) (count)	2.D. Advance Warning Signs (Check all that apply; include count) <input type="checkbox"/> None <input checked="" type="checkbox"/> W10-1 <input type="checkbox"/> W10-3 <input type="checkbox"/> W10-11 <input type="checkbox"/> W10-2 <input type="checkbox"/> W10-4 <input type="checkbox"/> W10-12	
2.E. Low Ground Clearance Sign (W10-5) <input type="checkbox"/> Yes (count _____) <input type="checkbox"/> No		2.F. Pavement Markings <input type="checkbox"/> Stop Lines <input type="checkbox"/> Dynamic Envelope <input type="checkbox"/> RR Xing Symbols <input checked="" type="checkbox"/> None		2.G. Channelization Devices/Medians <input type="checkbox"/> All Approaches <input type="checkbox"/> Median <input type="checkbox"/> One Approach <input type="checkbox"/> None	2.H. EXEMPT Sign (R15-3) <input type="checkbox"/> Yes <input type="checkbox"/> No
2.J. Other MUTCD Signs Specify Type _____ Count <u>2</u> Specify Type _____ Count <u>0</u> Specify Type _____ Count _____		2.K. Private Crossing Signs (if private) <input type="checkbox"/> Yes <input type="checkbox"/> No		2.L. LED Enhanced Signs (List types)	
3. Types of Train Activated Warning Devices at the Grade Crossing (specify count of each device for all that apply)					
3.A. Gate Arms (count) Roadway <u>2</u> Pedestrian _____		3.B. Gate Configuration <input type="checkbox"/> 2 Quad <input type="checkbox"/> Full (Barrier) <input type="checkbox"/> 3 Quad Resistance <input type="checkbox"/> 4 Quad <input type="checkbox"/> Median Gates		3.C. Cantilevered (or Bridged) Flashing Light Structures (count) Over Traffic Lane <u>0</u> <input type="checkbox"/> Incandescent Not Over Traffic Lane <u>0</u> <input type="checkbox"/> LED	3.D. Mast Mounted Flashing Lights (count of masts) <u>2</u> <input type="checkbox"/> Incandescent <input type="checkbox"/> LED <input type="checkbox"/> Back Lights Included <input type="checkbox"/> Side Lights Included
3.F. Installation Date of Current Active Warning Devices: (MM/YYYY) ____/____/____ <input type="checkbox"/> Not Required		3.G. Wayside Horn <input type="checkbox"/> Yes Installed on (MM/YYYY) ____/____/____ <input type="checkbox"/> No		3.H. Highway Traffic Signals Controlling Crossing <input type="checkbox"/> Yes <input checked="" type="checkbox"/> No	3.I. Bells (count) 1
3.J. Non-Train Active Warning <input type="checkbox"/> Flagging/Flagman <input type="checkbox"/> Manually Operated Signals <input type="checkbox"/> Watchman <input type="checkbox"/> Floodlighting <input type="checkbox"/> None				3.K. Other Flashing Lights or Warning Devices Count <u>0</u> Specify type _____	
4.A. Does nearby Hwy Intersection have Traffic Signals? <input type="checkbox"/> Yes <input type="checkbox"/> No		4.B. Hwy Traffic Signal Interconnection <input type="checkbox"/> Not Interconnected <input type="checkbox"/> For Traffic Signals <input type="checkbox"/> For Warning Signs	4.C. Hwy Traffic Signal Preemption <input type="checkbox"/> Simultaneous <input type="checkbox"/> Advance	5. Highway Traffic Pre-Signals <input type="checkbox"/> Yes <input type="checkbox"/> No Storage Distance * _____ Stop Line Distance * _____	6. Highway Monitoring Devices (Check all that apply) <input type="checkbox"/> Yes - Photo/Video Recording <input type="checkbox"/> Yes - Vehicle Presence Detection <input type="checkbox"/> None
<b>Part IV: Physical Characteristics</b>					
1. Traffic Lanes Crossing Railroad Number of Lanes <u>2</u>		<input type="checkbox"/> One-way Traffic <input type="checkbox"/> Two-way Traffic <input type="checkbox"/> Divided Traffic	2. Is Roadway/Pathway Paved? <input type="checkbox"/> Yes <input checked="" type="checkbox"/> No	3. Does Track Run Down a Street? <input type="checkbox"/> Yes <input checked="" type="checkbox"/> No	4. Is Crossing Illuminated? (Street lights within approx. 50 feet from nearest rail) <input type="checkbox"/> Yes <input type="checkbox"/> No
5. Crossing Surface (on Main Track, multiple types allowed) Installation Date * (MM/YYYY) ____/____/____ Width * _____ Length * _____ <input type="checkbox"/> 1 Timber <input type="checkbox"/> 2 Asphalt <input type="checkbox"/> 3 Asphalt and Timber <input checked="" type="checkbox"/> 4 Concrete <input type="checkbox"/> 5 Concrete and Rubber <input type="checkbox"/> 6 Rubber <input type="checkbox"/> 7 Metal <input type="checkbox"/> 8 Unconsolidated <input type="checkbox"/> 9 Composite <input type="checkbox"/> 10 Other (specify) _____					
6. Intersecting Roadway within 500 feet? <input type="checkbox"/> Yes <input checked="" type="checkbox"/> No If Yes, Approximate Distance (feet) _____			7. Smallest Crossing Angle <input type="checkbox"/> 0° - 29° <input checked="" type="checkbox"/> 30° - 59° <input type="checkbox"/> 60° - 90°		8. Is Commercial Power Available? * <input checked="" type="checkbox"/> Yes <input type="checkbox"/> No
<b>Part V: Public Highway Information</b>					
1. Highway System <input type="checkbox"/> (01) Interstate Highway System <input type="checkbox"/> (02) Other Nat Hwy System (NHS) <input type="checkbox"/> (03) Federal AID, Not NHS <input checked="" type="checkbox"/> (08) Non-Federal Aid		2. Functional Classification of Road at Crossing <input checked="" type="checkbox"/> (0) Rural <input type="checkbox"/> (1) Urban <input type="checkbox"/> (1) Interstate <input type="checkbox"/> (5) Major Collector <input type="checkbox"/> (2) Other Freeways and Expressways <input type="checkbox"/> (3) Other Principal Arterial <input type="checkbox"/> (6) Minor Collector <input type="checkbox"/> (4) Minor Arterial <input checked="" type="checkbox"/> (7) Local		3. Is Crossing on State Highway System? <input type="checkbox"/> Yes <input checked="" type="checkbox"/> No	4. Highway Speed Limit _____ MPH <input type="checkbox"/> Posted <input type="checkbox"/> Statutory
7. Annual Average Daily Traffic (AADT) Year <u>1987</u> AADT <u>000110</u>		8. Estimated Percent Trucks <u>18</u> %	9. Regularly Used by School Buses? <input type="checkbox"/> Yes <input checked="" type="checkbox"/> No Average Number per Day <u>0</u>		10. Emergency Services Route <input type="checkbox"/> Yes <input type="checkbox"/> No
<b>Submission Information - This information is used for administrative purposes and is not available on the public website.</b>					
Submitted by _____ Organization _____ Phone _____ Date _____					
Public reporting burden for this information collection is estimated to average 30 minutes per response, including the time for reviewing instructions, searching existing data sources, gathering and maintaining the data needed and completing and reviewing the collection of information. According to the Paperwork Reduction Act of 1995, a federal agency may not conduct or sponsor, and a person is not required to, nor shall a person be subject to a penalty for failure to comply with, a collection of information unless it displays a currently valid OMB control number. The valid OMB control number for information collection is 2130-0017. Send comments regarding this burden estimate or any other aspect of this collection, including for reducing this burden to: Information Collection Officer, Federal Railroad Administration, 1200 New Jersey Ave. SE, MS-25 Washington, DC 20590.					

Figure A-6. Crossing 083312L Inventory Form – Page 2 [44]

**U. S. DOT CROSSING INVENTORY FORM**

DEPARTMENT OF TRANSPORTATION  
FEDERAL RAILROAD ADMINISTRATION

OMB No. 2130-0017

Instructions for the initial reporting of the following types of new or previously unreported crossings: For public highway-rail grade crossings, complete the entire inventory Form. For private highway-rail grade crossings, complete the Header, Parts I and II, and the Submission Information section. For public pathway grade crossings (including pedestrian station grade crossings), complete the Header, Parts I and II, and the Submission Information section. For Private pathway grade crossings, complete the Header, Parts I and II, and the Submission Information section. For grade-separated highway-rail or pathway crossings (including pedestrian station crossings), complete the Header, Part I, and the Submission Information section. For changes to existing data, complete the Header, Part I Items 1-3, and the Submission Information section, in addition to the updated data fields. Note: For private crossings only, Part I Item 20 and Part III Item 2.K. are required unless otherwise noted. An asterisk \* denotes an optional field.

<b>A. Revision Date</b> (MM/DD/YYYY) 04 / 19 / 2016	<b>B. Reporting Agency</b> <input type="checkbox"/> Railroad <input type="checkbox"/> Transit <input checked="" type="checkbox"/> State <input type="checkbox"/> Other	<b>C. Reason for Update (Select only one)</b> <input checked="" type="checkbox"/> Change in Data <input type="checkbox"/> Re-Open <input type="checkbox"/> New Crossing <input type="checkbox"/> Date Change Only <input type="checkbox"/> Closed <input type="checkbox"/> Change in Primary Operating RR <input type="checkbox"/> No Train Traffic <input type="checkbox"/> Quiet Zone Update <input type="checkbox"/> Admin. Correction	<b>D. DOT Crossing Inventory Number</b> 083410C
---	--	--	--

**Part I: Location and Classification Information**

<b>1. Primary Operating Railroad</b> BNSF Railway Company [BNSF]		<b>2. State</b> NEBRASKA		<b>3. County</b> HAMILTON		
<b>4. City / Municipality</b> <input type="checkbox"/> In <input checked="" type="checkbox"/> Near HAMPTON		<b>5. Street/Road Name &amp; Block Number</b> 1ST STREET (Street/Road Name) * (Block Number)		<b>6. Highway Type &amp; No.</b> NSL410		
<b>7. Do Other Railroads Operate a Separate Track at Crossing?</b> <input type="checkbox"/> Yes <input checked="" type="checkbox"/> No If Yes, Specify RR			<b>8. Do Other Railroads Operate Over Your Track at Crossing?</b> <input type="checkbox"/> Yes <input checked="" type="checkbox"/> No If Yes, Specify RR			
<b>9. Railroad Division or Region</b> <input type="checkbox"/> None NEBRASKA		<b>10. Railroad Subdivision or District</b> <input type="checkbox"/> None RAVENNA		<b>11. Branch or Line Name</b> <input type="checkbox"/> None LINCOLN-RAVENNA		
<b>12. RR Milepost</b> 0071.12 (prefix)   (nnnn.nnn)   (suffix)		<b>13. Line Segment</b> * 0004				
<b>14. Nearest RR Timetable Station</b> * HAMPTON		<b>15. Parent RR (if applicable)</b> <input type="checkbox"/> N/A		<b>16. Crossing Owner (if applicable)</b> <input type="checkbox"/> N/A BNSF		
<b>17. Crossing Type</b> <input checked="" type="checkbox"/> Public <input type="checkbox"/> Private	<b>18. Crossing Purpose</b> <input checked="" type="checkbox"/> Highway <input type="checkbox"/> Pathway, Ped. <input type="checkbox"/> Station, Ped.	<b>19. Crossing Position</b> <input checked="" type="checkbox"/> At Grade <input type="checkbox"/> RR Under <input type="checkbox"/> RR Over	<b>20. Public Access (if Private Crossing)</b> <input type="checkbox"/> Yes <input type="checkbox"/> No	<b>21. Type of Train</b> <input type="checkbox"/> Freight <input type="checkbox"/> Intercity Passenger <input type="checkbox"/> Commuter <input type="checkbox"/> Transit <input type="checkbox"/> Shared Use Transit <input type="checkbox"/> Tourist/Other	<b>22. Average Passenger Train Count Per Day</b> <input type="checkbox"/> Less Than One Per Day <input type="checkbox"/> Number Per Day 0	
<b>23. Type of Land Use</b> <input type="checkbox"/> Open Space <input type="checkbox"/> Farm <input type="checkbox"/> Residential <input type="checkbox"/> Commercial <input checked="" type="checkbox"/> Industrial <input type="checkbox"/> Institutional <input type="checkbox"/> Recreational <input type="checkbox"/> RR Yard						
<b>24. Is there an Adjacent Crossing with a Separate Number?</b> <input type="checkbox"/> Yes <input type="checkbox"/> No If Yes, Provide Crossing Number			<b>25. Quiet Zone (FRA provided)</b> <input checked="" type="checkbox"/> No <input type="checkbox"/> 24 Hr <input type="checkbox"/> Partial <input type="checkbox"/> Chicago Excused Date Established			
<b>26. HSR Corridor ID</b> <input checked="" type="checkbox"/> N/A		<b>27. Latitude in decimal degrees</b> (WGS84 std: nn.nnnnnnn) 40.8781492		<b>28. Longitude in decimal degrees</b> (WGS84 std: -nnn.nnnnnnn) -97.8833350		
<b>29. Lat/Long Source</b> <input checked="" type="checkbox"/> Actual <input type="checkbox"/> Estimated						
<b>30.A. Railroad Use *</b>			<b>31.A. State Use *</b>			
<b>30.B. Railroad Use *</b>			<b>31.B. State Use *</b>			
<b>30.C. Railroad Use *</b>			<b>31.C. State Use *</b>			
<b>30.D. Railroad Use *</b>			<b>31.D. State Use *</b>			
<b>32.A. Narrative (Railroad Use) *</b>			<b>32.B. Narrative (State Use) *</b>			
<b>33. Emergency Notification Telephone No. (posted)</b> 800-832-5452		<b>34. Railroad Contact (Telephone No.)</b> 817-352-1549		<b>35. State Contact (Telephone No.)</b> 402-479-4515		

**Part II: Railroad Information**

<b>1. Estimated Number of Daily Train Movements</b>				
<b>1.A. Total Day Thru Trains (6 AM to 6 PM)</b> 30	<b>1.B. Total Night Thru Trains (6 PM to 6 AM)</b> 29	<b>1.C. Total Switching Trains</b> 1	<b>1.D. Total Transit Trains</b>	<b>1.E. Check if Less Than One Movement Per Day</b> <input type="checkbox"/> How many trains per week? _____
<b>2. Year of Train Count Data (YYYY)</b>		<b>3. Speed of Train at Crossing</b> 3.A. Maximum Timetable Speed (mph) 60 3.B. Typical Speed Range Over Crossing (mph) From 1 to 60		
<b>4. Type and Count of Tracks</b> Main 1 Siding _____ Yard _____ Transit _____ Industry _____				
<b>5. Train Detection (Main Track only)</b> <input type="checkbox"/> Constant Warning Time <input checked="" type="checkbox"/> Motion Detection <input type="checkbox"/> AFO <input type="checkbox"/> PTC <input type="checkbox"/> DC <input type="checkbox"/> Other <input type="checkbox"/> None				
<b>6. Is Track Signaled?</b> <input checked="" type="checkbox"/> Yes <input type="checkbox"/> No		<b>7.A. Event Recorder</b> <input type="checkbox"/> Yes <input type="checkbox"/> No		<b>7.B. Remote Health Monitoring</b> <input type="checkbox"/> Yes <input type="checkbox"/> No

Figure A-7. Crossing 083410C Inventory Form – Page 1 [44]

**U. S. DOT CROSSING INVENTORY FORM**

A. Revision Date (MM/DD/YYYY) 04/19/2016		PAGE 2		D. Crossing Inventory Number (7 char.) 083410C		
<b>Part III: Highway or Pathway Traffic Control Device Information</b>						
1. Are there Signs or Signals? <input checked="" type="checkbox"/> Yes <input type="checkbox"/> No		2. Types of Passive Traffic Control Devices associated with the Crossing				
2.A. Crossbuck Assemblies (count) 2		2.B. STOP Signs (R1-1) (count) 0	2.C. YIELD Signs (R1-2) (count)	2.D. Advance Warning Signs (Check all that apply; include count) <input type="checkbox"/> None <input checked="" type="checkbox"/> W10-1 <input type="checkbox"/> W10-3 <input type="checkbox"/> W10-11 <input type="checkbox"/> W10-2 <input type="checkbox"/> W10-4 <input type="checkbox"/> W10-12		
2.E. Low Ground Clearance Sign (W10-5) <input type="checkbox"/> Yes (count _____) <input type="checkbox"/> No		2.F. Pavement Markings <input type="checkbox"/> Stop Lines <input type="checkbox"/> Dynamic Envelope <input type="checkbox"/> RR Xing Symbols <input checked="" type="checkbox"/> None		2.G. Channelization Devices/Medians <input type="checkbox"/> All Approaches <input type="checkbox"/> Median <input type="checkbox"/> One Approach <input type="checkbox"/> None	2.H. EXEMPT Sign (R15-3) <input type="checkbox"/> Yes <input type="checkbox"/> No	2.I. ENS Sign (I-13) Displayed <input type="checkbox"/> Yes <input checked="" type="checkbox"/> No
2.J. Other MUTCD Signs Specify Type _____ Count 1 Specify Type _____ Count 0 Specify Type _____ Count _____		<input checked="" type="checkbox"/> Yes <input type="checkbox"/> No		2.K. Private Crossing Signs (if private) <input type="checkbox"/> Yes <input type="checkbox"/> No	2.L. LED Enhanced Signs (List types)	
<b>3. Types of Train Activated Warning Devices at the Grade Crossing (specify count of each device for all that apply)</b>						
3.A. Gate Arms (count) Roadway 2 Pedestrian _____		3.B. Gate Configuration <input type="checkbox"/> 2 Quad <input type="checkbox"/> Full (Barrier) <input type="checkbox"/> 3 Quad Resistance <input type="checkbox"/> 4 Quad <input type="checkbox"/> Median Gates		3.C. Cantilevered (or Bridged) Flashing Light Structures (count) Over Traffic Lane 0 <input type="checkbox"/> Incandescent Not Over Traffic Lane 0 <input type="checkbox"/> LED	3.D. Mast Mounted Flashing Lights (count of masts) 2 <input type="checkbox"/> Incandescent <input type="checkbox"/> LED <input type="checkbox"/> Back Lights Included <input type="checkbox"/> Side Lights Included	3.E. Total Count of Flashing Light Pairs 2
3.F. Installation Date of Current Active Warning Devices: (MM/YYYY) ____/____/____ <input checked="" type="checkbox"/> Not Required		3.G. Wayside Horn <input type="checkbox"/> Yes Installed on (MM/YYYY) ____/____/____ <input type="checkbox"/> No		3.H. Highway Traffic Signals Controlling Crossing <input type="checkbox"/> Yes <input checked="" type="checkbox"/> No	3.I. Bells (count) 1	
3.J. Non-Train Active Warning <input type="checkbox"/> Flagger/Flagman <input type="checkbox"/> Manually Operated Signals <input type="checkbox"/> Watchman <input type="checkbox"/> Floodlighting <input type="checkbox"/> None				3.K. Other Flashing Lights or Warning Devices Count 0 Specify type _____		
4.A. Does nearby Hwy Intersection have Traffic Signals? <input type="checkbox"/> Yes <input type="checkbox"/> No		4.B. Hwy Traffic Signal Interconnection <input checked="" type="checkbox"/> Not Interconnected <input type="checkbox"/> For Traffic Signals <input type="checkbox"/> For Warning Signs	4.C. Hwy Traffic Signal Preemption <input type="checkbox"/> Simultaneous <input type="checkbox"/> Advance	5. Highway Traffic Pre-Signals <input type="checkbox"/> Yes <input type="checkbox"/> No Storage Distance * _____ Stop Line Distance * _____	6. Highway Monitoring Devices (Check all that apply) <input type="checkbox"/> Yes - Photo/Video Recording <input type="checkbox"/> Yes - Vehicle Presence Detection <input type="checkbox"/> None	
<b>Part IV: Physical Characteristics</b>						
1. Traffic Lanes Crossing Railroad Number of Lanes 2		<input type="checkbox"/> One-way Traffic <input type="checkbox"/> Two-way Traffic <input type="checkbox"/> Divided Traffic	2. Is Roadway/Pathway Paved? <input checked="" type="checkbox"/> Yes <input type="checkbox"/> No	3. Does Track Run Down a Street? <input type="checkbox"/> Yes <input checked="" type="checkbox"/> No	4. Is Crossing Illuminated? (Street lights within approx. 50 feet from nearest rail) <input type="checkbox"/> Yes <input type="checkbox"/> No	
5. Crossing Surface (on Main Track, multiple types allowed) Installation Date * (MM/YYYY) ____/____/____ Width * _____ Length * _____ <input checked="" type="checkbox"/> 1 Timber <input type="checkbox"/> 2 Asphalt <input type="checkbox"/> 3 Asphalt and Timber <input type="checkbox"/> 4 Concrete <input type="checkbox"/> 5 Concrete and Rubber <input type="checkbox"/> 6 Rubber <input type="checkbox"/> 7 Metal <input type="checkbox"/> 8 Unconsolidated <input type="checkbox"/> 9 Composite <input type="checkbox"/> 10 Other (specify) _____						
6. Intersecting Roadway within 500 feet? <input checked="" type="checkbox"/> Yes <input type="checkbox"/> No If Yes, Approximate Distance (feet) 200			7. Smallest Crossing Angle <input type="checkbox"/> 0° - 29° <input type="checkbox"/> 30° - 59° <input checked="" type="checkbox"/> 60° - 90°		8. Is Commercial Power Available? * <input checked="" type="checkbox"/> Yes <input type="checkbox"/> No	
<b>Part V: Public Highway Information</b>						
1. Highway System <input type="checkbox"/> (01) Interstate Highway System <input type="checkbox"/> (02) Other Nat Hwy System (NHS) <input checked="" type="checkbox"/> (03) Federal AID, Not NHS <input type="checkbox"/> (08) Non-Federal Aid		2. Functional Classification of Road at Crossing <input checked="" type="checkbox"/> (0) Rural <input type="checkbox"/> (1) Urban <input type="checkbox"/> (1) Interstate <input checked="" type="checkbox"/> (5) Major Collector <input type="checkbox"/> (2) Other Freeways and Expressways <input type="checkbox"/> (3) Other Principal Arterial <input type="checkbox"/> (6) Minor Collector <input type="checkbox"/> (4) Minor Arterial <input type="checkbox"/> (7) Local		3. Is Crossing on State Highway System? <input checked="" type="checkbox"/> Yes <input type="checkbox"/> No	4. Highway Speed Limit 35 MPH <input checked="" type="checkbox"/> Posted <input type="checkbox"/> Statutory	
7. Annual Average Daily Traffic (AADT) Year 2014 AADT 460		8. Estimated Percent Trucks 09 %	9. Regularly Used by School Buses? <input type="checkbox"/> Yes <input checked="" type="checkbox"/> No Average Number per Day 0		10. Emergency Services Route <input type="checkbox"/> Yes <input type="checkbox"/> No	
<b>Submission Information - This information is used for administrative purposes and is not available on the public website.</b>						
Submitted by _____ Organization _____ Phone _____ Date _____						
Public reporting burden for this information collection is estimated to average 30 minutes per response, including the time for reviewing instructions, searching existing data sources, gathering and maintaining the data needed and completing and reviewing the collection of information. According to the Paperwork Reduction Act of 1995, a federal agency may not conduct or sponsor, and a person is not required to, nor shall a person be subject to a penalty for failure to comply with, a collection of information unless it displays a currently valid OMB control number. The valid OMB control number for information collection is 2130-0017. Send comments regarding this burden estimate or any other aspect of this collection, including for reducing this burden to: Information Collection Officer, Federal Railroad Administration, 1200 New Jersey Ave. SE, MS-25 Washington, DC 20590.						

Figure A-8. Crossing 083410C Inventory Form – Page 2 [44]

**U. S. DOT CROSSING INVENTORY FORM**

DEPARTMENT OF TRANSPORTATION  
FEDERAL RAILROAD ADMINISTRATION

OMB No. 2130-0017

Instructions for the initial reporting of the following types of new or previously unreported crossings: For public highway-rail grade crossings, complete the entire inventory Form. For private highway-rail grade crossings, complete the Header, Parts I and II, and the Submission Information section. For public pathway grade crossings (including pedestrian station grade crossings), complete the Header, Parts I and II, and the Submission Information section. For Private pathway grade crossings, complete the Header, Parts I and II, and the Submission Information section. For grade-separated highway-rail or pathway crossings (including pedestrian station crossings), complete the Header, Part I, and the Submission Information section. For changes to existing data, complete the Header, Part I Items 1-3, and the Submission Information section, in addition to the updated data fields. Note: For private crossings only, Part I Item 20 and Part III Item 2.K. are required unless otherwise noted. An asterisk \* denotes an optional field.

<b>A. Revision Date</b> (MM/DD/YYYY) 05 / 08 / 2017		<b>B. Reporting Agency</b> <input checked="" type="checkbox"/> Railroad <input type="checkbox"/> Transit <input type="checkbox"/> State <input type="checkbox"/> Other		<b>C. Reason for Update (Select only one)</b> <input checked="" type="checkbox"/> Change in Data <input type="checkbox"/> Re-Open <input type="checkbox"/> New Crossing <input type="checkbox"/> Date Change Only <input type="checkbox"/> Closed <input type="checkbox"/> Change in Primary Operating RR <input type="checkbox"/> No Train Traffic <input type="checkbox"/> Quiet Zone Update <input type="checkbox"/> Admin. Correction			<b>D. DOT Crossing Inventory Number</b> 817404F
<b>Part I: Location and Classification Information</b>							
<b>1. Primary Operating Railroad</b> Union Pacific Railroad Company [UP]			<b>2. State</b> NEBRASKA		<b>3. County</b> SARPY		
<b>4. City / Municipality</b> <input checked="" type="checkbox"/> In <input type="checkbox"/> Near BELLEVUE		<b>5. Street/Road Name &amp; Block Number</b> KASPER ROAD (Street/Road Name) * (Block Number)			<b>6. Highway Type &amp; No.</b> CITY		
<b>7. Do Other Railroads Operate a Separate Track at Crossing?</b> <input type="checkbox"/> Yes <input checked="" type="checkbox"/> No If Yes, Specify RR				<b>8. Do Other Railroads Operate Over Your Track at Crossing?</b> <input type="checkbox"/> Yes <input checked="" type="checkbox"/> No If Yes, Specify RR			
<b>9. Railroad Division or Region</b> <input type="checkbox"/> None COUNCIL BLUFFS		<b>10. Railroad Subdivision or District</b> <input type="checkbox"/> None Falls City		<b>11. Branch or Line Name</b> <input checked="" type="checkbox"/> None		<b>12. RR Milepost</b> 0474.460 (prefix)   (nnnn.nnn)   (suffix)	
<b>13. Line Segment</b> *		<b>14. Nearest RR Timetable Station</b> *		<b>15. Parent RR (if applicable)</b> <input checked="" type="checkbox"/> N/A		<b>16. Crossing Owner (if applicable)</b> <input checked="" type="checkbox"/> N/A	
<b>17. Crossing Type</b> <input checked="" type="checkbox"/> Public <input type="checkbox"/> Private	<b>18. Crossing Purpose</b> <input checked="" type="checkbox"/> Highway <input type="checkbox"/> Pathway, Ped. <input type="checkbox"/> Station, Ped.	<b>19. Crossing Position</b> <input checked="" type="checkbox"/> At Grade <input type="checkbox"/> RR Under <input type="checkbox"/> RR Over	<b>20. Public Access (if Private Crossing)</b> <input type="checkbox"/> Yes <input type="checkbox"/> No		<b>21. Type of Train</b> <input checked="" type="checkbox"/> Freight <input type="checkbox"/> Intercity Passenger <input type="checkbox"/> Commuter <input type="checkbox"/> Transit <input type="checkbox"/> Shared Use Transit <input type="checkbox"/> Tourist/Other		
<b>22. Average Passenger Train Count Per Day</b> <input type="checkbox"/> Less Than One Per Day <input type="checkbox"/> Number Per Day 0							
<b>23. Type of Land Use</b> <input type="checkbox"/> Open Space <input type="checkbox"/> Farm <input type="checkbox"/> Residential <input checked="" type="checkbox"/> Commercial <input type="checkbox"/> Industrial <input type="checkbox"/> Institutional <input type="checkbox"/> Recreational <input type="checkbox"/> RR Yard							
<b>24. Is there an Adjacent Crossing with a Separate Number?</b> <input type="checkbox"/> Yes <input checked="" type="checkbox"/> No If Yes, Provide Crossing Number				<b>25. Quiet Zone (FRA provided)</b> <input checked="" type="checkbox"/> No <input type="checkbox"/> 24 Hr <input type="checkbox"/> Partial <input type="checkbox"/> Chicago Excused Date Established			
<b>26. HSR Corridor ID</b> <input checked="" type="checkbox"/> N/A		<b>27. Latitude in decimal degrees</b> (WGS84 std: nn.nnnnnn) 41.1673405		<b>28. Longitude in decimal degrees</b> (WGS84 std: -nnn.nnnnnn) -95.9257944		<b>29. Lat/Long Source</b> <input checked="" type="checkbox"/> Actual <input type="checkbox"/> Estimated	
<b>30.A. Railroad Use *</b>			<b>31.A. State Use *</b>				
<b>30.B. Railroad Use *</b>			<b>31.B. State Use *</b>				
<b>30.C. Railroad Use *</b>			<b>31.C. State Use *</b>				
<b>30.D. Railroad Use *</b>			<b>31.D. State Use *</b>				
<b>32.A. Narrative (Railroad Use) *</b>			<b>32.B. Narrative (State Use) *</b>				
<b>33. Emergency Notification Telephone No. (posted)</b> 800-848-8715		<b>34. Railroad Contact (Telephone No.)</b> 402-544-3721			<b>35. State Contact (Telephone No.)</b> 402-479-4515		
<b>Part II: Railroad Information</b>							
<b>1. Estimated Number of Daily Train Movements</b>							
<b>1.A. Total Day Thru Trains (6 AM to 6 PM)</b> 5		<b>1.B. Total Night Thru Trains (6 PM to 6 AM)</b> 5	<b>1.C. Total Switching Trains</b> 0	<b>1.D. Total Transit Trains</b> 0	<b>1.E. Check if Less Than One Movement Per Day</b> <input type="checkbox"/> How many trains per week? _____		
<b>2. Year of Train Count Data (YYYY)</b> 2017		<b>3. Speed of Train at Crossing</b> 3.A. Maximum Timetable Speed (mph) 40 3.B. Typical Speed Range Over Crossing (mph) From 20 to 40					
<b>4. Type and Count of Tracks</b> Main 1 Siding 0 Yard 0 Transit 0 Industry 0							
<b>5. Train Detection (Main Track only)</b> <input type="checkbox"/> Constant Warning Time <input type="checkbox"/> Motion Detection <input type="checkbox"/> AFO <input type="checkbox"/> PTC <input type="checkbox"/> DC <input checked="" type="checkbox"/> Other <input type="checkbox"/> None							
<b>6. Is Track Signaled?</b> <input checked="" type="checkbox"/> Yes <input type="checkbox"/> No			<b>7.A. Event Recorder</b> <input type="checkbox"/> Yes <input checked="" type="checkbox"/> No		<b>7.B. Remote Health Monitoring</b> <input type="checkbox"/> Yes <input checked="" type="checkbox"/> No		

Figure A-9. Crossing 817404F Inventory Form – Page 1 [44]



**U. S. DOT CROSSING INVENTORY FORM**

A. Revision Date (MM/DD/YYYY) 05/08/2017		PAGE 2		D. Crossing Inventory Number (7 char.) 817404F	
<b>Part III: Highway or Pathway Traffic Control Device Information</b>					
1. Are there Signs or Signals? <input checked="" type="checkbox"/> Yes <input type="checkbox"/> No		2. Types of Passive Traffic Control Devices associated with the Crossing			
2.A. Crossbuck Assemblies (count) 0		2.B. STOP Signs (R1-1) (count) 0	2.C. YIELD Signs (R1-2) (count)	2.D. Advance Warning Signs (Check all that apply; include count) <input type="checkbox"/> None <input checked="" type="checkbox"/> W10-1 <input type="checkbox"/> W10-3 <input type="checkbox"/> W10-11 <input type="checkbox"/> W10-2 <input type="checkbox"/> W10-4 <input type="checkbox"/> W10-12	
2.E. Low Ground Clearance Sign (W10-5) <input type="checkbox"/> Yes (count 0) <input checked="" type="checkbox"/> No		2.F. Pavement Markings <input type="checkbox"/> Stop Lines <input type="checkbox"/> Dynamic Envelope <input type="checkbox"/> RR Xing Symbols <input checked="" type="checkbox"/> None		2.G. Channelization Devices/Medians <input type="checkbox"/> All Approaches <input type="checkbox"/> Median <input type="checkbox"/> One Approach <input type="checkbox"/> None	2.H. EXEMPT Sign (R15-3) <input type="checkbox"/> Yes <input checked="" type="checkbox"/> No
2.J. Other MUTCD Signs Specify Type _____ Count 0 Specify Type _____ Count 0 Specify Type _____ Count _____		2.K. Private Crossing Signs (if private) <input type="checkbox"/> Yes <input type="checkbox"/> No	2.L. LED Enhanced Signs (List types)		
<b>3. Types of Train Activated Warning Devices at the Grade Crossing (specify count of each device for all that apply)</b>					
3.A. Gate Arms (count) Roadway 2 Pedestrian _____		3.B. Gate Configuration <input checked="" type="checkbox"/> 2 Quad <input type="checkbox"/> Full (Barrier) <input type="checkbox"/> 3 Quad Resistance <input type="checkbox"/> Median Gates <input type="checkbox"/> 4 Quad	3.C. Cantilevered (or Bridged) Flashing Light Structures (count) Over Traffic Lane 0 <input type="checkbox"/> Incandescent Not Over Traffic Lane 0 <input type="checkbox"/> LED		3.D. Mast Mounted Flashing Lights (count of masts) 2 <input type="checkbox"/> Incandescent <input checked="" type="checkbox"/> LED <input checked="" type="checkbox"/> Back Lights Included <input type="checkbox"/> Side Lights Included
3.F. Installation Date of Current Active Warning Devices: (MM/YYYY) ____/____/____ <input checked="" type="checkbox"/> Not Required		3.G. Wayside Horn <input type="checkbox"/> Yes Installed on (MM/YYYY) ____/____/____ <input type="checkbox"/> No		3.H. Highway Traffic Signals Controlling Crossing <input type="checkbox"/> Yes <input checked="" type="checkbox"/> No	3.I. Bells (count) 2
3.J. Non-Train Active Warning <input type="checkbox"/> Flagging/Flagman <input type="checkbox"/> Manually Operated Signals <input type="checkbox"/> Watchman <input type="checkbox"/> Floodlighting <input type="checkbox"/> None				3.K. Other Flashing Lights or Warning Devices Count 0 Specify type _____	
4.A. Does nearby Hwy Intersection have Traffic Signals? <input type="checkbox"/> Yes <input type="checkbox"/> No		4.B. Hwy Traffic Signal Interconnection <input checked="" type="checkbox"/> Not Interconnected <input type="checkbox"/> For Traffic Signals <input type="checkbox"/> For Warning Signs	4.C. Hwy Traffic Signal Preemption <input type="checkbox"/> Simultaneous <input type="checkbox"/> Advance	5. Highway Traffic Pre-Signals <input type="checkbox"/> Yes <input checked="" type="checkbox"/> No Storage Distance * _____ Stop Line Distance * _____	6. Highway Monitoring Devices (Check all that apply) <input type="checkbox"/> Yes - Photo/Video Recording <input type="checkbox"/> Yes - Vehicle Presence Detection <input type="checkbox"/> None
<b>Part IV: Physical Characteristics</b>					
1. Traffic Lanes Crossing Railroad Number of Lanes 2 <input type="checkbox"/> One-way Traffic <input type="checkbox"/> Two-way Traffic <input type="checkbox"/> Divided Traffic		2. Is Roadway/Pathway Paved? <input checked="" type="checkbox"/> Yes <input type="checkbox"/> No	3. Does Track Run Down a Street? <input type="checkbox"/> Yes <input checked="" type="checkbox"/> No	4. Is Crossing Illuminated? (Street lights within approx. 50 feet from nearest rail) <input type="checkbox"/> Yes <input checked="" type="checkbox"/> No	
5. Crossing Surface (on Main Track, multiple types allowed) Installation Date * (MM/YYYY) ____/____/____ Width * _____ Length * _____ <input checked="" type="checkbox"/> 1 Timber <input type="checkbox"/> 2 Asphalt <input type="checkbox"/> 3 Asphalt and Timber <input type="checkbox"/> 4 Concrete <input type="checkbox"/> 5 Concrete and Rubber <input type="checkbox"/> 6 Rubber <input type="checkbox"/> 7 Metal <input type="checkbox"/> 8 Unconsolidated <input type="checkbox"/> 9 Composite <input type="checkbox"/> 10 Other (specify) _____					
6. Intersecting Roadway within 500 feet? <input checked="" type="checkbox"/> Yes <input type="checkbox"/> No If Yes, Approximate Distance (feet) 200			7. Smallest Crossing Angle <input type="checkbox"/> 0° - 29° <input type="checkbox"/> 30° - 59° <input checked="" type="checkbox"/> 60° - 90°	8. Is Commercial Power Available? * <input checked="" type="checkbox"/> Yes <input type="checkbox"/> No	
<b>Part V: Public Highway Information</b>					
1. Highway System <input type="checkbox"/> (01) Interstate Highway System <input type="checkbox"/> (02) Other Nat Hwy System (NHS) <input type="checkbox"/> (03) Federal AID, Not NHS <input checked="" type="checkbox"/> (08) Non-Federal Aid		2. Functional Classification of Road at Crossing <input checked="" type="checkbox"/> (0) Rural <input type="checkbox"/> (1) Urban <input type="checkbox"/> (1) Interstate <input type="checkbox"/> (5) Major Collector <input type="checkbox"/> (2) Other Freeways and Expressways <input type="checkbox"/> (3) Other Principal Arterial <input type="checkbox"/> (6) Minor Collector <input type="checkbox"/> (4) Minor Arterial <input checked="" type="checkbox"/> (7) Local		3. Is Crossing on State Highway System? <input type="checkbox"/> Yes <input checked="" type="checkbox"/> No	4. Highway Speed Limit 50 MPH <input checked="" type="checkbox"/> Posted <input type="checkbox"/> Statutory
7. Annual Average Daily Traffic (AADT) Year 1993 AADT 200		8. Estimated Percent Trucks 03 %	9. Regularly Used by School Buses? <input type="checkbox"/> Yes <input checked="" type="checkbox"/> No Average Number per Day 0		10. Emergency Services Route <input type="checkbox"/> Yes <input type="checkbox"/> No
<b>Submission Information - This information is used for administrative purposes and is not available on the public website.</b>					
Submitted by _____ Organization _____ Phone _____ Date _____					
Public reporting burden for this information collection is estimated to average 30 minutes per response, including the time for reviewing instructions, searching existing data sources, gathering and maintaining the data needed and completing and reviewing the collection of information. According to the Paperwork Reduction Act of 1995, a federal agency may not conduct or sponsor, and a person is not required to, nor shall a person be subject to a penalty for failure to comply with, a collection of information unless it displays a currently valid OMB control number. The valid OMB control number for information collection is 2130-0017. Send comments regarding this burden estimate or any other aspect of this collection, including for reducing this burden to: Information Collection Officer, Federal Railroad Administration, 1200 New Jersey Ave. SE, MS-25 Washington, DC 20590.					

Figure A-10. Crossing 817404F Inventory Form – Page 2 [44]

**U. S. DOT CROSSING INVENTORY FORM**

DEPARTMENT OF TRANSPORTATION  
FEDERAL RAILROAD ADMINISTRATION

OMB No. 2130-0017

Instructions for the initial reporting of the following types of new or previously unreported crossings: For public highway-rail grade crossings, complete the entire inventory Form. For private highway-rail grade crossings, complete the Header, Parts I and II, and the Submission Information section. For public pathway grade crossings (including pedestrian station grade crossings), complete the Header, Parts I and II, and the Submission Information section. For Private pathway grade crossings, complete the Header, Parts I and II, and the Submission Information section. For grade-separated highway-rail or pathway crossings (including pedestrian station crossings), complete the Header, Part I, and the Submission Information section. For changes to existing data, complete the Header, Part I Items 1-3, and the Submission Information section, in addition to the updated data fields. Note: For private crossings only, Part I Item 20 and Part III Item 2.K. are required unless otherwise noted. An asterisk \* denotes an optional field.

<b>A. Revision Date</b> (MM/DD/YYYY) 11 / 14 / 2016	<b>B. Reporting Agency</b> <input checked="" type="checkbox"/> Railroad <input type="checkbox"/> Transit <input type="checkbox"/> State <input type="checkbox"/> Other	<b>C. Reason for Update (Select only one)</b> <input checked="" type="checkbox"/> Change in Data <input type="checkbox"/> Re-Open <input type="checkbox"/> New Crossing <input type="checkbox"/> Date Change Only <input type="checkbox"/> Closed <input type="checkbox"/> Change in Primary Operating RR <input type="checkbox"/> No Train Traffic <input type="checkbox"/> Quiet Zone Update <input type="checkbox"/> Admin. Correction	<b>D. DOT Crossing Inventory Number</b> 817405M
---	--	--	--

**Part I: Location and Classification Information**

<b>1. Primary Operating Railroad</b> Union Pacific Railroad Company [UP]		<b>2. State</b> NEBRASKA		<b>3. County</b> SARPY	
<b>4. City / Municipality</b> <input checked="" type="checkbox"/> In <input type="checkbox"/> Near BELLEVUE		<b>5. Street/Road Name &amp; Block Number</b> AVERY ROAD (Street/Road Name) * (Block Number)		<b>6. Highway Type &amp; No.</b> CITY	
<b>7. Do Other Railroads Operate a Separate Track at Crossing?</b> <input type="checkbox"/> Yes <input checked="" type="checkbox"/> No If Yes, Specify RR			<b>8. Do Other Railroads Operate Over Your Track at Crossing?</b> <input type="checkbox"/> Yes <input checked="" type="checkbox"/> No If Yes, Specify RR		
<b>9. Railroad Division or Region</b> <input type="checkbox"/> None COUNCIL BLUFFS		<b>10. Railroad Subdivision or District</b> <input type="checkbox"/> None Falls City		<b>11. Branch or Line Name</b> <input checked="" type="checkbox"/> None	
<b>12. RR Milepost</b> 0474.310 (prefix)   (nnnn.nnn)   (suffix)		<b>13. Line Segment</b> *			
<b>14. Nearest RR Timetable Station</b> *		<b>15. Parent RR (if applicable)</b> <input checked="" type="checkbox"/> N/A		<b>16. Crossing Owner (if applicable)</b> <input checked="" type="checkbox"/> N/A	
<b>17. Crossing Type</b> <input checked="" type="checkbox"/> Public <input type="checkbox"/> Private	<b>18. Crossing Purpose</b> <input checked="" type="checkbox"/> Highway <input type="checkbox"/> Pathway, Ped. <input type="checkbox"/> Station, Ped.	<b>19. Crossing Position</b> <input checked="" type="checkbox"/> At Grade <input type="checkbox"/> RR Under <input type="checkbox"/> RR Over	<b>20. Public Access (if Private Crossing)</b> <input type="checkbox"/> Yes <input checked="" type="checkbox"/> No	<b>21. Type of Train</b> <input checked="" type="checkbox"/> Freight <input type="checkbox"/> Intercity Passenger <input type="checkbox"/> Commuter	<input type="checkbox"/> Transit <input type="checkbox"/> Shared Use Transit <input type="checkbox"/> Tourist/Other
<b>22. Average Passenger Train Count Per Day</b> <input type="checkbox"/> Less Than One Per Day <input type="checkbox"/> Number Per Day 0					
<b>23. Type of Land Use</b> <input type="checkbox"/> Open Space <input type="checkbox"/> Farm <input type="checkbox"/> Residential <input type="checkbox"/> Commercial <input checked="" type="checkbox"/> Industrial <input type="checkbox"/> Institutional <input type="checkbox"/> Recreational <input type="checkbox"/> RR Yard					
<b>24. Is there an Adjacent Crossing with a Separate Number?</b> <input type="checkbox"/> Yes <input checked="" type="checkbox"/> No If Yes, Provide Crossing Number			<b>25. Quiet Zone (FRA provided)</b> <input checked="" type="checkbox"/> No <input type="checkbox"/> 24 Hr <input type="checkbox"/> Partial <input type="checkbox"/> Chicago Excused Date Established		
<b>26. HSR Corridor ID</b> <input checked="" type="checkbox"/> N/A	<b>27. Latitude in decimal degrees</b> (WGS84 std: nn.nnnnnn) 41.1649608	<b>28. Longitude in decimal degrees</b> (WGS84 std: -nnn.nnnnnn) -95.9258526	<b>29. Lat/Long Source</b> <input checked="" type="checkbox"/> Actual <input type="checkbox"/> Estimated		
<b>30.A. Railroad Use *</b>			<b>31.A. State Use *</b>		
<b>30.B. Railroad Use *</b>			<b>31.B. State Use *</b>		
<b>30.C. Railroad Use *</b>			<b>31.C. State Use *</b>		
<b>30.D. Railroad Use *</b>			<b>31.D. State Use *</b>		
<b>32.A. Narrative (Railroad Use) *</b>			<b>32.B. Narrative (State Use) *</b>		
<b>33. Emergency Notification Telephone No. (posted)</b> 800-848-8715		<b>34. Railroad Contact (Telephone No.)</b> 402-544-3721		<b>35. State Contact (Telephone No.)</b> 402-479-4515	

**Part II: Railroad Information**

<b>1. Estimated Number of Daily Train Movements</b>				
<b>1.A. Total Day Thru Trains (6 AM to 6 PM)</b> 5	<b>1.B. Total Night Thru Trains (6 PM to 6 AM)</b> 5	<b>1.C. Total Switching Trains</b> 0	<b>1.D. Total Transit Trains</b> 0	<b>1.E. Check if Less Than One Movement Per Day</b> <input type="checkbox"/> How many trains per week? _____
<b>2. Year of Train Count Data (YYYY)</b> 2016		<b>3. Speed of Train at Crossing</b> 3.A. Maximum Timetable Speed (mph) 40 3.B. Typical Speed Range Over Crossing (mph) From 20 to 40		
<b>4. Type and Count of Tracks</b> Main 1 Siding 0 Yard 0 Transit 0 Industry 0				
<b>5. Train Detection (Main Track only)</b> <input type="checkbox"/> Constant Warning Time <input type="checkbox"/> Motion Detection <input type="checkbox"/> AFO <input type="checkbox"/> PTC <input type="checkbox"/> DC <input checked="" type="checkbox"/> Other <input type="checkbox"/> None				
<b>6. Is Track Signaled?</b> <input checked="" type="checkbox"/> Yes <input type="checkbox"/> No		<b>7.A. Event Recorder</b> <input type="checkbox"/> Yes <input checked="" type="checkbox"/> No		<b>7.B. Remote Health Monitoring</b> <input type="checkbox"/> Yes <input checked="" type="checkbox"/> No

Figure A-11. Crossing 817405M Inventory Form – Page 1 [44]

**U. S. DOT CROSSING INVENTORY FORM**

A. Revision Date (MM/DD/YYYY) 11/14/2016		PAGE 2		D. Crossing Inventory Number (7 char.) 817405M		
<b>Part III: Highway or Pathway Traffic Control Device Information</b>						
1. Are there Signs or Signals? <input checked="" type="checkbox"/> Yes <input type="checkbox"/> No		2. Types of Passive Traffic Control Devices associated with the Crossing				
2.A. Crossbuck Assemblies (count) 2		2.B. STOP Signs (R1-1) (count) 0	2.C. YIELD Signs (R1-2) (count)	2.D. Advance Warning Signs (Check all that apply; include count) <input type="checkbox"/> None <input checked="" type="checkbox"/> W10-1 <input type="checkbox"/> W10-3 <input type="checkbox"/> W10-11 <input type="checkbox"/> W10-2 <input type="checkbox"/> W10-4 <input type="checkbox"/> W10-12		
2.E. Low Ground Clearance Sign (W10-5) <input type="checkbox"/> Yes (count 0) <input checked="" type="checkbox"/> No		2.F. Pavement Markings <input type="checkbox"/> Stop Lines <input type="checkbox"/> Dynamic Envelope <input type="checkbox"/> RR Xing Symbols <input checked="" type="checkbox"/> None		2.G. Channelization Devices/Medians <input type="checkbox"/> All Approaches <input type="checkbox"/> Median <input type="checkbox"/> One Approach <input type="checkbox"/> None	2.H. EXEMPT Sign (R15-3) <input type="checkbox"/> Yes <input checked="" type="checkbox"/> No	2.I. ENS Sign (I-13) Displayed <input type="checkbox"/> Yes <input checked="" type="checkbox"/> No
2.J. Other MUTCD Signs Specify Type _____ Count 0 Specify Type _____ Count 0 Specify Type _____ Count _____			2.K. Private Crossing Signs (if private) <input type="checkbox"/> Yes <input type="checkbox"/> No	2.L. LED Enhanced Signs (List types)		
<b>3. Types of Train Activated Warning Devices at the Grade Crossing (specify count of each device for all that apply)</b>						
3.A. Gate Arms (count) Roadway 2 Pedestrian _____		3.B. Gate Configuration <input type="checkbox"/> 2 Quad <input type="checkbox"/> Full (Barrier) <input type="checkbox"/> 3 Quad Resistance <input type="checkbox"/> 4 Quad <input type="checkbox"/> Median Gates	3.C. Cantilevered (or Bridged) Flashing Light Structures (count) Over Traffic Lane 0 <input type="checkbox"/> Incandescent Not Over Traffic Lane 0 <input type="checkbox"/> LED		3.D. Mast Mounted Flashing Lights (count of masts) 3 <input type="checkbox"/> Incandescent <input type="checkbox"/> LED <input type="checkbox"/> Back Lights Included <input type="checkbox"/> Side Lights Included	3.E. Total Count of Flashing Light Pairs 2
3.F. Installation Date of Current Active Warning Devices: (MM/YYYY) ____/____/____ <input checked="" type="checkbox"/> Not Required		3.G. Wayside Horn <input type="checkbox"/> Yes Installed on (MM/YYYY) ____/____/____ <input type="checkbox"/> No		3.H. Highway Traffic Signals Controlling Crossing <input type="checkbox"/> Yes <input checked="" type="checkbox"/> No	3.I. Bells (count) 2	
3.J. Non-Train Active Warning <input type="checkbox"/> Flagging/Flagman <input type="checkbox"/> Manually Operated Signals <input type="checkbox"/> Watchman <input type="checkbox"/> Floodlighting <input type="checkbox"/> None				3.K. Other Flashing Lights or Warning Devices Count 0 Specify type _____		
4.A. Does nearby Hwy Intersection have Traffic Signals? <input type="checkbox"/> Yes <input type="checkbox"/> No		4.B. Hwy Traffic Signal Interconnection <input checked="" type="checkbox"/> Not Interconnected <input type="checkbox"/> For Traffic Signals <input type="checkbox"/> For Warning Signs	4.C. Hwy Traffic Signal Preemption <input type="checkbox"/> Simultaneous <input type="checkbox"/> Advance	5. Highway Traffic Pre-Signals <input type="checkbox"/> Yes <input checked="" type="checkbox"/> No Storage Distance * _____ Stop Line Distance * _____	6. Highway Monitoring Devices (Check all that apply) <input type="checkbox"/> Yes - Photo/Video Recording <input type="checkbox"/> Yes - Vehicle Presence Detection <input type="checkbox"/> None	
<b>Part IV: Physical Characteristics</b>						
1. Traffic Lanes Crossing Railroad Number of Lanes 2 <input type="checkbox"/> One-way Traffic <input type="checkbox"/> Two-way Traffic <input type="checkbox"/> Divided Traffic		2. Is Roadway/Pathway Paved? <input checked="" type="checkbox"/> Yes <input type="checkbox"/> No	3. Does Track Run Down a Street? <input type="checkbox"/> Yes <input checked="" type="checkbox"/> No	4. Is Crossing Illuminated? (Street lights within approx. 50 feet from nearest rail) <input type="checkbox"/> Yes <input checked="" type="checkbox"/> No		
5. Crossing Surface (on Main Track, multiple types allowed) Installation Date * (MM/YYYY) ____/____/____ Width * _____ Length * _____ <input checked="" type="checkbox"/> 1 Timber <input type="checkbox"/> 2 Asphalt <input type="checkbox"/> 3 Asphalt and Timber <input type="checkbox"/> 4 Concrete <input type="checkbox"/> 5 Concrete and Rubber <input type="checkbox"/> 6 Rubber <input type="checkbox"/> 7 Metal <input type="checkbox"/> 8 Unconsolidated <input type="checkbox"/> 9 Composite <input type="checkbox"/> 10 Other (specify) _____						
6. Intersecting Roadway within 500 feet? <input checked="" type="checkbox"/> Yes <input type="checkbox"/> No If Yes, Approximate Distance (feet) 75			7. Smallest Crossing Angle <input type="checkbox"/> 0° - 29° <input type="checkbox"/> 30° - 59° <input checked="" type="checkbox"/> 60° - 90°	8. Is Commercial Power Available? * <input checked="" type="checkbox"/> Yes <input type="checkbox"/> No		
<b>Part V: Public Highway Information</b>						
1. Highway System <input type="checkbox"/> (01) Interstate Highway System <input type="checkbox"/> (02) Other Nat Hwy System (NHS) <input type="checkbox"/> (03) Federal AID, Not NHS <input checked="" type="checkbox"/> (08) Non-Federal Aid		2. Functional Classification of Road at Crossing <input checked="" type="checkbox"/> (0) Rural <input type="checkbox"/> (1) Urban <input type="checkbox"/> (1) Interstate <input type="checkbox"/> (5) Major Collector <input type="checkbox"/> (2) Other Freeways and Expressways <input type="checkbox"/> (3) Other Principal Arterial <input type="checkbox"/> (6) Minor Collector <input type="checkbox"/> (4) Minor Arterial <input checked="" type="checkbox"/> (7) Local		3. Is Crossing on State Highway System? <input type="checkbox"/> Yes <input checked="" type="checkbox"/> No	4. Highway Speed Limit 25 MPH <input checked="" type="checkbox"/> Posted <input type="checkbox"/> Statutory	
7. Annual Average Daily Traffic (AADT) Year 1993 AADT 200		8. Estimated Percent Trucks 01 %	9. Regularly Used by School Buses? <input type="checkbox"/> Yes <input checked="" type="checkbox"/> No Average Number per Day 0		10. Emergency Services Route <input type="checkbox"/> Yes <input type="checkbox"/> No	
<b>Submission Information - This information is used for administrative purposes and is not available on the public website.</b>						
Submitted by _____ Organization _____ Phone _____ Date _____						
Public reporting burden for this information collection is estimated to average 30 minutes per response, including the time for reviewing instructions, searching existing data sources, gathering and maintaining the data needed and completing and reviewing the collection of information. According to the Paperwork Reduction Act of 1995, a federal agency may not conduct or sponsor, and a person is not required to, nor shall a person be subject to a penalty for failure to comply with, a collection of information unless it displays a currently valid OMB control number. The valid OMB control number for information collection is 2130-0017. Send comments regarding this burden estimate or any other aspect of this collection, including for reducing this burden to: Information Collection Officer, Federal Railroad Administration, 1200 New Jersey Ave. SE, MS-25 Washington, DC 20590.						

Figure A-12. Crossing 817405M Inventory Form – Page 2 [44]

**U. S. DOT CROSSING INVENTORY FORM**

DEPARTMENT OF TRANSPORTATION  
FEDERAL RAILROAD ADMINISTRATION

OMB No. 2130-0017

Instructions for the initial reporting of the following types of new or previously unreported crossings: For public highway-rail grade crossings, complete the entire inventory Form. For private highway-rail grade crossings, complete the Header, Parts I and II, and the Submission Information section. For public pathway grade crossings (including pedestrian station grade crossings), complete the Header, Parts I and II, and the Submission Information section. For Private pathway grade crossings, complete the Header, Parts I and II, and the Submission Information section. For grade-separated highway-rail or pathway crossings (including pedestrian station crossings), complete the Header, Part I, and the Submission Information section. For changes to existing data, complete the Header, Part I Items 1-3, and the Submission Information section, in addition to the updated data fields. Note: For private crossings only, Part I Item 20 and Part III Item 2.K. are required unless otherwise noted. An asterisk \* denotes an optional field.

<b>A. Revision Date</b> (MM/DD/YYYY) 11 / 14 / 2016		<b>B. Reporting Agency</b> <input checked="" type="checkbox"/> Railroad <input type="checkbox"/> Transit <input type="checkbox"/> State <input type="checkbox"/> Other		<b>C. Reason for Update (Select only one)</b> <input checked="" type="checkbox"/> Change in Data <input type="checkbox"/> Re-Open <input type="checkbox"/> New Crossing <input type="checkbox"/> Date Change Only <input type="checkbox"/> Closed <input type="checkbox"/> Change in Primary Operating RR <input type="checkbox"/> No Train Traffic <input type="checkbox"/> Quiet Zone Update <input type="checkbox"/> Admin. Correction			<b>D. DOT Crossing Inventory Number</b> 816134F
<b>Part I: Location and Classification Information</b>							
<b>1. Primary Operating Railroad</b> Union Pacific Railroad Company [UP]			<b>2. State</b> NEBRASKA		<b>3. County</b> SARPY		
<b>4. City / Municipality</b> <input checked="" type="checkbox"/> In <input type="checkbox"/> Near BELLEVUE		<b>5. Street/Road Name &amp; Block Number</b> CARY STREET (Street/Road Name) * (Block Number)			<b>6. Highway Type &amp; No.</b> CITY		
<b>7. Do Other Railroads Operate a Separate Track at Crossing?</b> <input type="checkbox"/> Yes <input checked="" type="checkbox"/> No If Yes, Specify RR				<b>8. Do Other Railroads Operate Over Your Track at Crossing?</b> <input type="checkbox"/> Yes <input checked="" type="checkbox"/> No If Yes, Specify RR			
<b>9. Railroad Division or Region</b> <input type="checkbox"/> None COUNCIL BLUFFS		<b>10. Railroad Subdivision or District</b> <input type="checkbox"/> None Falls City		<b>11. Branch or Line Name</b> <input checked="" type="checkbox"/> None		<b>12. RR Milepost</b> 0474.810 (prefix)   (nnnn.nnn)   (suffix)	
<b>13. Line Segment</b> *		<b>14. Nearest RR Timetable Station</b> *		<b>15. Parent RR (if applicable)</b> <input checked="" type="checkbox"/> N/A		<b>16. Crossing Owner (if applicable)</b> <input checked="" type="checkbox"/> N/A	
<b>17. Crossing Type</b> <input checked="" type="checkbox"/> Public <input type="checkbox"/> Private	<b>18. Crossing Purpose</b> <input checked="" type="checkbox"/> Highway <input type="checkbox"/> Pathway, Ped. <input type="checkbox"/> Station, Ped.	<b>19. Crossing Position</b> <input checked="" type="checkbox"/> At Grade <input type="checkbox"/> RR Under <input type="checkbox"/> RR Over	<b>20. Public Access (if Private Crossing)</b> <input type="checkbox"/> Yes <input checked="" type="checkbox"/> No		<b>21. Type of Train</b> <input checked="" type="checkbox"/> Freight <input type="checkbox"/> Intercity Passenger <input type="checkbox"/> Commuter <input type="checkbox"/> Transit <input type="checkbox"/> Shared Use Transit <input type="checkbox"/> Tourist/Other		
<b>22. Average Passenger Train Count Per Day</b> <input type="checkbox"/> Less Than One Per Day <input type="checkbox"/> Number Per Day 0							
<b>23. Type of Land Use</b> <input type="checkbox"/> Open Space <input type="checkbox"/> Farm <input type="checkbox"/> Residential <input checked="" type="checkbox"/> Commercial <input type="checkbox"/> Industrial <input type="checkbox"/> Institutional <input type="checkbox"/> Recreational <input type="checkbox"/> RR Yard							
<b>24. Is there an Adjacent Crossing with a Separate Number?</b> <input type="checkbox"/> Yes <input checked="" type="checkbox"/> No If Yes, Provide Crossing Number				<b>25. Quiet Zone (FRA provided)</b> <input checked="" type="checkbox"/> No <input type="checkbox"/> 24 Hr <input type="checkbox"/> Partial <input type="checkbox"/> Chicago Excused Date Established			
<b>26. HSR Corridor ID</b> <input checked="" type="checkbox"/> N/A		<b>27. Latitude in decimal degrees</b> (WGS84 std: nn.nnnnnn) 41.1728345		<b>28. Longitude in decimal degrees</b> (WGS84 std: -nnn.nnnnnn) -95.9261083		<b>29. Lat/Long Source</b> <input checked="" type="checkbox"/> Actual <input type="checkbox"/> Estimated	
<b>30.A. Railroad Use *</b>			<b>31.A. State Use *</b>				
<b>30.B. Railroad Use *</b>			<b>31.B. State Use *</b>				
<b>30.C. Railroad Use *</b>			<b>31.C. State Use *</b>				
<b>30.D. Railroad Use *</b>			<b>31.D. State Use *</b>				
<b>32.A. Narrative (Railroad Use) *</b>			<b>32.B. Narrative (State Use) *</b>				
<b>33. Emergency Notification Telephone No. (posted)</b> 800-848-8715		<b>34. Railroad Contact (Telephone No.)</b> 402-544-3721			<b>35. State Contact (Telephone No.)</b> 402-479-4515		
<b>Part II: Railroad Information</b>							
<b>1. Estimated Number of Daily Train Movements</b>							
<b>1.A. Total Day Thru Trains (6 AM to 6 PM)</b> 5	<b>1.B. Total Night Thru Trains (6 PM to 6 AM)</b> 5	<b>1.C. Total Switching Trains</b> 0	<b>1.D. Total Transit Trains</b> 0	<b>1.E. Check if Less Than One Movement Per Day</b> <input type="checkbox"/> How many trains per week? _____			
<b>2. Year of Train Count Data (YYYY)</b> 2016		<b>3. Speed of Train at Crossing</b> 3.A. Maximum Timetable Speed (mph) 40 3.B. Typical Speed Range Over Crossing (mph) From 20 to 40					
<b>4. Type and Count of Tracks</b> Main 1 Siding 0 Yard 0 Transit 0 Industry 0							
<b>5. Train Detection (Main Track only)</b> <input type="checkbox"/> Constant Warning Time <input type="checkbox"/> Motion Detection <input type="checkbox"/> AFO <input type="checkbox"/> PTC <input type="checkbox"/> DC <input checked="" type="checkbox"/> Other <input type="checkbox"/> None							
<b>6. Is Track Signaled?</b> <input checked="" type="checkbox"/> Yes <input type="checkbox"/> No			<b>7.A. Event Recorder</b> <input type="checkbox"/> Yes <input checked="" type="checkbox"/> No		<b>7.B. Remote Health Monitoring</b> <input type="checkbox"/> Yes <input checked="" type="checkbox"/> No		

Figure A-13. Crossing 816134F Inventory Form – Page 1 [44]

U. S. DOT CROSSING INVENTORY FORM

A. Revision Date (MM/DD/YYYY) 11/14/2016		PAGE 2		D. Crossing Inventory Number (7 char.) 816134F	
<b>Part III: Highway or Pathway Traffic Control Device Information</b>					
1. Are there Signs or Signals? <input checked="" type="checkbox"/> Yes <input type="checkbox"/> No	2. Types of Passive Traffic Control Devices associated with the Crossing		2.D. Advance Warning Signs (Check all that apply; include count) <input type="checkbox"/> None		
	2.A. Crossbuck Assemblies (count) 2	2.B. STOP Signs (R1-1) (count) 0	2.C. YIELD Signs (R1-2) (count)	<input checked="" type="checkbox"/> W10-1 <input type="checkbox"/> W10-2	<input type="checkbox"/> W10-3 <input type="checkbox"/> W10-4
2.E. Low Ground Clearance Sign (W10-5) <input type="checkbox"/> Yes (count 0) <input checked="" type="checkbox"/> No	2.F. Pavement Markings <input type="checkbox"/> Stop Lines <input type="checkbox"/> Dynamic Envelope <input type="checkbox"/> RR Xing Symbols <input checked="" type="checkbox"/> None		2.G. Channelization Devices/Medians <input type="checkbox"/> All Approaches <input type="checkbox"/> Median <input type="checkbox"/> One Approach <input type="checkbox"/> None	2.H. EXEMPT Sign (R15-3) <input type="checkbox"/> Yes <input checked="" type="checkbox"/> No	2.I. ENS Sign (I-13) Displayed <input type="checkbox"/> Yes <input checked="" type="checkbox"/> No
2.J. Other MUTCD Signs Specify Type _____ Count 0 Specify Type _____ Count 0 Specify Type _____ Count _____		2.K. Private Crossing Signs (if private) <input type="checkbox"/> Yes <input type="checkbox"/> No		2.L. LED Enhanced Signs (List types)	
<b>3. Types of Train Activated Warning Devices at the Grade Crossing (specify count of each device for all that apply)</b>					
3.A. Gate Arms (count) Roadway 2 Pedestrian _____	3.B. Gate Configuration <input type="checkbox"/> 2 Quad <input type="checkbox"/> Full (Barrier) <input type="checkbox"/> 3 Quad Resistance <input type="checkbox"/> 4 Quad <input type="checkbox"/> Median Gates	3.C. Cantilevered (or Bridged) Flashing Light Structures (count) Over Traffic Lane 0 <input type="checkbox"/> Incandescent Not Over Traffic Lane 0 <input type="checkbox"/> LED		3.D. Mast Mounted Flashing Lights (count of masts) 2 <input type="checkbox"/> Incandescent <input type="checkbox"/> LED <input type="checkbox"/> Back Lights Included <input type="checkbox"/> Side Lights Included	3.E. Total Count of Flashing Light Pairs 2
3.F. Installation Date of Current Active Warning Devices: (MM/YYYY) ____/____/____ <input checked="" type="checkbox"/> Not Required		3.G. Wayside Horn <input type="checkbox"/> Yes Installed on (MM/YYYY) ____/____/____ <input type="checkbox"/> No		3.H. Highway Traffic Signals Controlling Crossing <input type="checkbox"/> Yes <input checked="" type="checkbox"/> No	
3.I. Non-Train Active Warning <input type="checkbox"/> Flagging/Flagman <input type="checkbox"/> Manually Operated Signals <input type="checkbox"/> Watchman <input type="checkbox"/> Floodlighting <input type="checkbox"/> None			3.K. Other Flashing Lights or Warning Devices Count 0 Specify type _____		
4.A. Does nearby Hwy Intersection have Traffic Signals? <input type="checkbox"/> Yes <input type="checkbox"/> No	4.B. Hwy Traffic Signal Interconnection <input checked="" type="checkbox"/> Not Interconnected <input type="checkbox"/> For Traffic Signals <input type="checkbox"/> For Warning Signs	4.C. Hwy Traffic Signal Preemption <input type="checkbox"/> Simultaneous <input type="checkbox"/> Advance	5. Highway Traffic Pre-Signals <input type="checkbox"/> Yes <input checked="" type="checkbox"/> No Storage Distance * _____ Stop Line Distance * _____	6. Highway Monitoring Devices (Check all that apply) <input type="checkbox"/> Yes - Photo/Video Recording <input type="checkbox"/> Yes - Vehicle Presence Detection <input type="checkbox"/> None	
<b>Part IV: Physical Characteristics</b>					
1. Traffic Lanes Crossing Railroad Number of Lanes 2 <input type="checkbox"/> One-way Traffic <input type="checkbox"/> Two-way Traffic <input type="checkbox"/> Divided Traffic		2. Is Roadway/Pathway Paved? <input checked="" type="checkbox"/> Yes <input type="checkbox"/> No		3. Does Track Run Down a Street? <input type="checkbox"/> Yes <input checked="" type="checkbox"/> No	
5. Crossing Surface (on Main Track, multiple types allowed) Installation Date * (MM/YYYY) ____/____/____ Width * _____ Length * _____ <input checked="" type="checkbox"/> 1 Timber <input type="checkbox"/> 2 Asphalt <input type="checkbox"/> 3 Asphalt and Timber <input type="checkbox"/> 4 Concrete <input type="checkbox"/> 5 Concrete and Rubber <input type="checkbox"/> 6 Rubber <input type="checkbox"/> 7 Metal <input type="checkbox"/> 8 Unconsolidated <input type="checkbox"/> 9 Composite <input type="checkbox"/> 10 Other (specify) _____					
6. Intersecting Roadway within 500 feet? <input checked="" type="checkbox"/> Yes <input type="checkbox"/> No If Yes, Approximate Distance (feet) 200			7. Smallest Crossing Angle <input type="checkbox"/> 0° - 29° <input type="checkbox"/> 30° - 59° <input checked="" type="checkbox"/> 60° - 90°		8. Is Commercial Power Available? * <input checked="" type="checkbox"/> Yes <input type="checkbox"/> No
<b>Part V: Public Highway Information</b>					
1. Highway System <input type="checkbox"/> (01) Interstate Highway System <input type="checkbox"/> (02) Other Nat Hwy System (NHS) <input type="checkbox"/> (03) Federal AID, Not NHS <input checked="" type="checkbox"/> (08) Non-Federal Aid		2. Functional Classification of Road at Crossing <input checked="" type="checkbox"/> (0) Rural <input type="checkbox"/> (1) Urban <input type="checkbox"/> (1) Interstate <input type="checkbox"/> (5) Major Collector <input type="checkbox"/> (2) Other Freeways and Expressways <input type="checkbox"/> (3) Other Principal Arterial <input type="checkbox"/> (6) Minor Collector <input type="checkbox"/> (4) Minor Arterial <input checked="" type="checkbox"/> (7) Local		3. Is Crossing on State Highway System? <input type="checkbox"/> Yes <input checked="" type="checkbox"/> No	
7. Annual Average Daily Traffic (AADT) Year 1993 AADT 300		8. Estimated Percent Trucks 03 %		9. Regularly Used by School Buses? <input type="checkbox"/> Yes <input checked="" type="checkbox"/> No Average Number per Day 0	
				4. Highway Speed Limit 25 MPH <input checked="" type="checkbox"/> Posted <input type="checkbox"/> Statutory	
				5. Linear Referencing System (LRS Route ID) * 6. LRS Milepost *	
10. Emergency Services Route <input type="checkbox"/> Yes <input type="checkbox"/> No					
<b>Submission Information - This information is used for administrative purposes and is not available on the public website.</b>					
Submitted by _____ Organization _____ Phone _____ Date _____					
Public reporting burden for this information collection is estimated to average 30 minutes per response, including the time for reviewing instructions, searching existing data sources, gathering and maintaining the data needed and completing and reviewing the collection of information. According to the Paperwork Reduction Act of 1995, a federal agency may not conduct or sponsor, and a person is not required to, nor shall a person be subject to a penalty for failure to comply with, a collection of information unless it displays a currently valid OMB control number. The valid OMB control number for information collection is 2130-0017. Send comments regarding this burden estimate or any other aspect of this collection, including for reducing this burden to: Information Collection Officer, Federal Railroad Administration, 1200 New Jersey Ave. SE, MS-25 Washington, DC 20590.					

Figure A-14. Crossing 816134F Inventory Form – Page 2 [44]

## **Appendix B. Accident Reports**

Accident reports for crossings 073062Y, 073158N, and 083312L are provided in this appendix. There are no accident reports for crossings 083410C, 817404F, 817405M, or 816134F.



HIGHWAY-RAIL GRADE CROSSING  
ACCIDENT/INCIDENT REPORT

DEPARTMENT OF TRANSPORTATION  
FEDERAL RAILROAD ADMINISTRATION (FRA)

OMB Approval No. 2130-0500

Name Of		Alphabetic Code	RR Accident/Incident No.
1. Reporting Railroad BNSF Railway Company [BNSF]		1a. BNSF	1b. NE0805200
2. Other Railroad Involved in Train Accident/Incident		2a.	2b.
3. Railroad Responsible for Track Maintenance BNSF Railway Company [BNSF]		3a. BNSF	3b. NE0805200
4. U.S. DOT-AAR Grade Crossing ID No. 073062Y	5. Date of Accident/Incident 08/04/05	6. Time of Accident/Incident 07:00 AM	
7. Nearest Railroad Station BELLEVUE	8. Division NEBRASKA	9. County SARPY	10. State Abbr. 31 Code NE
11. City (if in a city)	12. Highway Name or No. PRIVATE		<input type="checkbox"/> Public <input checked="" type="checkbox"/> Private
Highway User Involved		Rail Equipment Involved	
13. Type C. Truck-trailer F. Bus J. Other Motor Vehicle A. Auto D. Pick-up truck G. School Bus K. Pedestrian B. Truck E. Van H. Motorcycle M. Other (specify)	Code C	17. Equipment 1. Train (units pulling) 2. Train (units pushing) 3. Train (standing)	4. Car(s) (moving) 5. Car(s) (standing) 6. Light loco(s) (moving) 7. Light loco(s) (standing) 8. Other (specify) A. Train pulling- RCL B. Train pushing- RCL C. Train standing- RCL
14. Vehicle Speed (est. mph at impact) 0	15. Direction (geographical) 1. North 2. South 3. East 4. West	Code 4	18. Position of Car Unit in Train 1
16. Position 1. Stalled on crossing 3. Moving over crossing 2. Stopped on Crossing 4. Trapped	Code 1	19. Circumstance 1. Rail equipment struck highway user 2. Rail equipment struck by highway user	Code 1
20a. Was the highway user and/or rail equipment involved in the impact transporting hazardous materials? 1. Highway User 2. Rail Equipment 3. Both 4. Neither	Code 2	20b. Was there a hazardous materials release by 1. Highway User 2. Rail Equipment 3. Both 4. Neither	Code 4
20c. State the name and quantity of the hazardous material released, if any			
21. Temperature (specify if minus) 70 °F	22. Visibility (single entry) 1. Dawn 2. Day 3. Dusk 4. Dark	Code 1	23. Weather (single entry) 1. Clear 2. Cloudy 3. Rain 4. Fog 5. Sleet 6. Snow
24. Type of Equipment Consist 1. Freight train 4. Work train 7. Yard/Switching (single entry) 2. Passenger train 5. Single car 8. Light loco(s) 3. Commuter train 6. Cut of cars 9. Main/inspect. car	A. Spec. MoW Equip Code 1	25. Track Type Used by Rail Equipment Involved 1. Main 2. Yard 3. Siding 4. Industry	Code 1 26. Track Number or Name MAIN
27. FRA Track Class 4	28. Number of Locomotive Units 3	29. Number of Cars 66	30. Consist Speed (Recorded if available) R. Recorded E. Estimated 20 mph Code E
31. Time Table Direction 1. North 2. South 3. East 4. West	Code 4		
32. Type of Crossing 1. Gates 4. Wig wags 7. Crossbucks 10. Flagged by crew 2. Cantilever FLS 5. Hwy. traffic signals 8. Stop signs 11. Other (specify) Warning 3. Standard FLS 6. Audible 9. Watchman 12. None	Code(s) 08 07	33. Signaled Crossing Warning	34. Whistle Ban 1. Yes 2. No 3. Unknown Code 2
35. Location of Warning 1. Both Sides 2. Side of Vehicle Approach 3. Opposite Side of Vehicle Approach	Code 1	36. Crossing Warning Interconnected with Highway Signals 1. Yes 2. No 3. Unknown	Code 3 37. Crossing Illuminated by Street Lights or Special Lights 1. Yes 2. No 3. Unknown Code 2
38. Driver's Age 39. Driver's Gender 1. Male 2. Female	Code 1	40. Driver Drove Behind or in Front of Train and Struck or was Struck by Second Train 1. Yes 2. No 3. Unknown	Code 2 41. Driver 1. Drove around or thru the gate 4. Stopped on crossing 2. Stopped and then proceeded 5. Other (specify) 3. Did not stop Code 5
42. Driver Passed Standing Highway Vehicle 1. Yes 2. No 3. Unknown	Code 2	43. View of Track Obscured by (primary obstruction) 1. Permanent Structure 3. Passing Train 5. Vegetation 7. Other (specify) 2. Standing railroad equipment 4. Topography 6. Highway Vehicles 8. Not Obstructed	Code 8
Casualties to:	Killed	Injured	44. Driver was 1. Killed 2. Injured 3. Uninjured Code 3 45. Was Driver in the Vehicle? 1. Yes 2. No Code 1
46. Highway-Rail Crossing Users	0	0	47. Highway Vehicle Property Damage (est. dollar damage) \$10,000 48. Total Number of Highway-Rail Crossing Users (include driver) 2
49. Railroad Employees	0	0	50. Total Number of People on Train (include passengers and crew) 2 51. Is a Rail Equipment Accident / Incident Report Being Filed 1. Yes 2. No Code 1
52. Passengers on Train	0	0	
53a. Special Study Block	53b. Special Study Block		
54. Narrative Description AGE OF DRIVER UNKNOWN, 41-LOWBOY HIGH CENTERED			
55. Typed Name and Title	56. Signature		57. Date

FORM FRA F 6180.57

\* NOTE THAT ALL CASUALTIES MUST BE REPORTED ON FORM FRA F 6180.55A

Figure B-1. Crossing 073062Y Accident Report – August 4, 2005 [44]

HIGHWAY-RAIL GRADE CROSSING  
ACCIDENT/INCIDENT REPORT

DEPARTMENT OF TRANSPORTATION  
FEDERAL RAILROAD ADMINISTRATION (FRA)

OMB Approval No. 2130-0500

Name Of		Alphabetic Code	RR Accident/Incident No.
1. Reporting Railroad Burlington Northern Railroad Company [BN]		1a. BN	1b. NE434
2. Other Railroad Involved in Train Accident/Incident		2a.	2b.
3. Railroad Responsible for Track Maintenance Burlington Northern Railroad Company [BN]		3a. BN	3b. NE434
4. U.S. DOT-AAR Grade Crossing ID No. 073158N	5. Date of Accident/Incident 07/10/83	6. Time of Accident/Incident 05:42 PM	
7. Nearest Railroad Station ASHLAND	8. Division	9. County SAUNDERS	10. State Abbr. 31 Code NE
11. City (if in a city)	12. Highway Name or No. 255 ST		<input checked="" type="checkbox"/> Public <input type="checkbox"/> Private
Highway User Involved		Rail Equipment Involved	
13. Type C. Truck-trailer F. Bus J. Other Motor Vehicle A. Auto D. Pick-up truck G. School Bus K. Pedestrian B. Truck E. Van H. Motorcycle M. Other (specify)	Code A	17. Equipment 1. Train (units pulling) 2. Train (units pushing) 3. Train (standing)	4. Car(s) (moving) 5. Car(s) (standing) 6. Light loco(s) (moving) 7. Light loco(s) (standing) 8. Other (specify) A. Train pulling- RCL B. Train pushing- RCL C. Train standing- RCL
14. Vehicle Speed (est. mph at impact) 5	15. Direction (geographical) 1. North 2. South 3. East 4. West	18. Position of Car Unit in Train	1
16. Position 1. Stalled on crossing 3. Moving over crossing 2. Stopped on Crossing 4. Trapped	Code 3	19. Circumstance 1. Rail equipment struck highway user 2. Rail equipment struck by highway user	Code 2
20a. Was the highway user and/or rail equipment involved in the impact transporting hazardous materials? 1. Highway User 2. Rail Equipment 3. Both 4. Neither	Code 4	20b. Was there a hazardous materials release by 1. Highway User 2. Rail Equipment 3. Both 4. Neither	Code
20c. State the name and quantity of the hazardous material released, if any			
21. Temperature (specify if minus) 85 °F	22. Visibility (single entry) 1. Dawn 2. Day 3. Dusk 4. Dark	23. Weather (single entry) 1. Clear 2. Cloudy 3. Rain 4. Fog 5. Sleet 6. Snow	Code 2 Code 1
24. Type of Equipment Consist 1. Freight train 4. Work train 7. Yard/Switching (single entry) 2. Passenger train 5. Single car 8. Light loco(s) 3. Commuter train 6. Cut of cars 9. Main/inspect. car	A. Spec. MoW Equip Code 1	25. Track Type Used by Rail Equipment Involved 1. Main 2. Yard 3. Siding 4. Industry	Code 1 26. Track Number or Name SINGLE MAIN
27. FRA Track Class 4	28. Number of Locomotive Units 3	29. Number of Cars 22	30. Consist Speed (Recorded if available) R. Recorded E. Estimated 50 mph Code E
31. Time Table Direction 1. North 2. South 3. East 4. West	Code 3		
32. Type of Crossing 1. Gates 4. Wig wags 7. Crossbucks 10. Flagged by crew 2. Cantilever FLS 5. Hwy. traffic signals 8. Stop signs 11. Other (specify) Warning 3. Standard FLS 6. Audible 9. Watchman 12. None	Code(s) 07	33. Signaled Crossing Warning	34. Whistle Ban 1. Yes 2. No 3. Unknown Code
35. Location of Warning 1. Both Sides 2. Side of Vehicle Approach 3. Opposite Side of Vehicle Approach	Code 1	36. Crossing Warning Interconnected with Highway Signals 1. Yes 2. No 3. Unknown	Code 2 37. Crossing Illuminated by Street Lights or Special Lights 1. Yes 2. No 3. Unknown Code 2
38. Driver's Age 39. Driver's Gender 1. Male 2. Female	Code	40. Driver Drove Behind or in Front of Train and Struck or was Struck by Second Train 1. Yes 2. No 3. Unknown	Code 2 41. Driver 1. Drove around or thru the gate 4. Stopped on crossing 2. Stopped and then proceeded 5. Other (specify) 3. Did not stop Code 3
42. Driver Passed Standing Highway Vehicle 1. Yes 2. No 3. Unknown	Code 2	43. View of Track Obscured by (primary obstruction) 1. Permanent Structure 3. Passing Train 5. Vegetation 7. Other (specify) 2. Standing railroad equipment 4. Topography 6. Highway Vehicles 8. Not Obstructed	Code 8
Casualties to:	Killed	Injured	44. Driver was 1. Killed 2. Injured 3. Uninjured Code 2 45. Was Driver in the Vehicle? 1. Yes 2. No Code 1
46. Highway-Rail Crossing Users	0	1	47. Highway Vehicle Property Damage (est. dollar damage) \$8,000 48. Total Number of Highway-Rail Crossing Users (include driver) 1
49. Railroad Employees	0	0	50. Total Number of People on Train (include passengers and crew)
52. Passengers on Train	0	0	51. Is a Rail Equipment Accident / Incident Report Being Filed 1. Yes 2. No Code 2
53a. Special Study Block	53b. Special Study Block		
54. Narrative Description			
55. Typed Name and Title	56. Signature		57. Date

FORM FRA F 6180.57

\* NOTE THAT ALL CASUALTIES MUST BE REPORTED ON FORM FRA F 6180.55A

Figure B-2. Crossing 073158N Accident Report – July 10, 1983 [44]

HIGHWAY-RAIL GRADE CROSSING  
ACCIDENT/INCIDENT REPORT

DEPARTMENT OF TRANSPORTATION  
FEDERAL RAILROAD ADMINISTRATION (FRA)

OMB Approval No. 2130-0500

Name Of		Alphabetic Code	RR Accident/Incident No.
1. Reporting Railroad Burlington Northern Railroad Company [BN]		1a. BN	1b. NE486
2. Other Railroad Involved in Train Accident/Incident		2a.	2b.
3. Railroad Responsible for Track Maintenance Burlington Northern Railroad Company [BN]		3a. BN	3b. NE486
4. U.S. DOT-AAR Grade Crossing ID No. 073158N	5. Date of Accident/Incident 08/02/82	6. Time of Accident/Incident 11:20 AM	
7. Nearest Railroad Station ASHLAND	8. Division	9. County SAUNDERS	10. State Abbr. 31 NE
11. City (if in a city)	12. Highway Name or No. HIGHWAY 6		<input checked="" type="checkbox"/> Public <input type="checkbox"/> Private
Highway User Involved		Rail Equipment Involved	
13. Type C. Truck-trailer F. Bus J. Other Motor Vehicle A. Auto D. Pick-up truck G. School Bus K. Pedestrian B. Truck E. Van H. Motorcycle M. Other (specify)	Code B	17. Equipment 1. Train (units pulling) 2. Train (units pushing) 3. Train (standing)	4. Car(s) (moving) 5. Car(s) (standing) 6. Light loco(s) (moving) 7. Light loco(s) (standing) 8. Other (specify) A. Train pulling- RCL B. Train pushing- RCL C. Train standing- RCL
14. Vehicle Speed (est. mph at impact) 15	15. Direction (geographical) 1. North 2. South 3. East 4. West	18. Position of Car Unit in Train 1	
16. Position 1. Stalled on crossing 3. Moving over crossing 2. Stopped on Crossing 4. Trapped	Code 3	19. Circumstance 1. Rail equipment struck highway user 2. Rail equipment struck by highway user	Code 2
20a. Was the highway user and/or rail equipment involved in the impact transporting hazardous materials? 1. Highway User 2. Rail Equipment 3. Both 4. Neither		20b. Was there a hazardous materials release by 1. Highway User 2. Rail Equipment 3. Both 4. Neither	
20c. State the name and quantity of the hazardous material released, if any			
21. Temperature (specify if minus) 95 °F	22. Visibility (single entry) 1. Dawn 2. Day 3. Dusk 4. Dark	23. Weather (single entry) 1. Clear 2. Cloudy 3. Rain 4. Fog 5. Sleet 6. Snow	
24. Type of Equipment Consist 1. Freight train 4. Work train 7. Yard/Switching (single entry) 2. Passenger train 5. Single car 8. Light loco(s) 3. Commuter train 6. Cut of cars 9. Main./inspect. car	A. Spec. MoW Equip Code 1	25. Track Type Used by Rail Equipment Involved 1. Main 2. Yard 3. Siding 4. Industry	Code 1
27. FRA Track Class 4	28. Number of Locomotive Units 3	29. Number of Cars 111	30. Consist Speed (Recorded if available) R. Recorded E. Estimated 50 mph
31. Time Table Direction 1. North 2. South 3. East 4. West	Code 4		
32. Type of Crossing 1. Gates 2. Cantilever FLS 3. Standard FLS 4. Wig wags 5. Hwy. traffic signals 6. Audible 7. Crossbucks 8. Stop signs 9. Watchman 10. Flagged by crew 11. Other (specify) 12. None	33. Signaled Crossing Warning	34. Whistle Ban 1. Yes 2. No 3. Unknown	
Code(s) 07	Code		
35. Location of Warning 1. Both Sides 2. Side of Vehicle Approach 3. Opposite Side of Vehicle Approach	Code 1	36. Crossing Warning Interconnected with Highway Signals 1. Yes 2. No 3. Unknown	Code 2
37. Crossing Illuminated by Street Lights or Special Lights 1. Yes 2. No 3. Unknown	Code 2		
38. Driver's Age 39. Driver's Gender 1. Male 2. Female	Code	40. Driver Drove Behind or in Front of Train and Struck or was Struck by Second Train 1. Yes 2. No 3. Unknown	Code 2
41. Driver 1. Drove around or thru the gate 2. Stopped and then proceeded 3. Did not stop	Code 3		
42. Driver Passed Standing Highway Vehicle 1. Yes 2. No 3. Unknown	Code 2	43. View of Track Obscured by (primary obstruction) 1. Permanent Structure 2. Standing railroad equipment 3. Passing Train 4. Topography 5. Vegetation 6. Highway Vehicles 7. Other (specify) 8. Not Obstructed	Code 8
Casualties to:	Killed	Injured	44. Driver was 1. Killed 2. Injured 3. Uninjured
	0	0	Code 3
45. Was Driver in the Vehicle? 1. Yes 2. No	Code 1		
46. Highway-Rail Crossing Users 0	0	47. Highway Vehicle Property Damage (est. dollar damage) \$500	48. Total Number of Highway-Rail Crossing Users (include driver) 1
49. Railroad Employees 0	0	50. Total Number of People on Train (include passengers and crew)	51. Is a Rail Equipment Accident / Incident Report Being Filed 1. Yes 2. No
52. Passengers on Train 0	0	Code 2	
53a. Special Study Block	53b. Special Study Block		
54. Narrative Description			
55. Typed Name and Title	56. Signature		57. Date

FORM FRA F 6180.57

\* NOTE THAT ALL CASUALTIES MUST BE REPORTED ON FORM FRA F 6180.55A

Figure B-3. Crossing 073158N Accident Report – August 2, 1982 [44]

HIGHWAY-RAIL GRADE CROSSING  
ACCIDENT/INCIDENT REPORT

DEPARTMENT OF TRANSPORTATION  
FEDERAL RAILROAD ADMINISTRATION (FRA)

OMB Approval No. 2130-0500

Name Of		Alphabetic Code	RR Accident/Incident No.
1. Reporting Railroad Burlington Northern Railroad Company [BN]		1a. BN	1b. NE0397
2. Other Railroad Involved in Train Accident/Incident		2a.	2b.
3. Railroad Responsible for Track Maintenance Burlington Northern Railroad Company [BN]		3a. BN	3b. NE0397
4. U.S. DOT-AAR Grade Crossing ID No. 073158N	5. Date of Accident/Incident 04/23/77	6. Time of Accident/Incident 01:10 AM	
7. Nearest Railroad Station ASHLAND	8. Division	9. County SAUNDERS	10. State Abbr. 31 Code NE
11. City (if in a city) ASHLAND	12. Highway Name or No. COUNTY RD MP 44-32		<input checked="" type="checkbox"/> Public <input type="checkbox"/> Private
Highway User Involved		Rail Equipment Involved	
13. Type C. Truck-trailer F. Bus J. Other Motor Vehicle A. Auto D. Pick-up truck G. School Bus K. Pedestrian B. Truck E. Van H. Motorcycle M. Other (specify)	Code A	17. Equipment 1. Train (units pulling) 2. Train (units pushing) 3. Train (standing)	4. Car(s) (moving) 5. Car(s) (standing) 6. Light loco(s) (moving) 7. Light loco(s) (standing) 8. Other (specify) A. Train pulling- RCL B. Train pushing- RCL C. Train standing- RCL
14. Vehicle Speed (est. mph at impact)	15. Direction (geographical) 1. North 2. South 3. East 4. West	18. Position of Car Unit in Train 1	
16. Position 1. Stalled on crossing 3. Moving over crossing 2. Stopped on Crossing 4. Trapped	Code 2	19. Circumstance 1. Rail equipment struck highway user 2. Rail equipment struck by highway user	Code 1
20a. Was the highway user and/or rail equipment involved in the impact transporting hazardous materials? 1. Highway User 2. Rail Equipment 3. Both 4. Neither		20b. Was there a hazardous materials release by 1. Highway User 2. Rail Equipment 3. Both 4. Neither	
20c. State the name and quantity of the hazardous material released, if any			
21. Temperature (specify if minus) 45 °F	22. Visibility (single entry) 1. Dawn 2. Day 3. Dusk 4. Dark	23. Weather (single entry) 1. Clear 2. Cloudy 3. Rain 4. Fog 5. Sleet 6. Snow	
24. Type of Equipment Consist 1. Freight train 4. Work train 7. Yard/Switching (single entry) 2. Passenger train 5. Single car 8. Light loco(s) 3. Commuter train 6. Cut of cars 9. Main/inspect. car	A. Spec. MoW Equip Code 1	25. Track Type Used by Rail Equipment Involved 1. Main 2. Yard 3. Siding 4. Industry	26. Track Number or Name 1 SINGLE MAIN
27. FRA Track Class 3	28. Number of Locomotive Units 3	29. Number of Cars 87	30. Consist Speed (Recorded if available) R. Recorded E. Estimated 50 mph Code E
31. Time Table Direction 1. North 2. South 3. East 4. West	Code 4		
32. Type of Crossing 1. Gates 4. Wig wags 7. Crossbucks 10. Flagged by crew 2. Cantilever FLS 5. Hwy. traffic signals 8. Stop signs 11. Other (specify) Warning 3. Standard FLS 6. Audible 9. Watchman 12. None	33. Signaled Crossing Warning		34. Whistle Ban 1. Yes 2. No 3. Unknown Code
Code(s) 12			
35. Location of Warning 1. Both Sides 2. Side of Vehicle Approach 3. Opposite Side of Vehicle Approach	Code	36. Crossing Warning Interconnected with Highway Signals 1. Yes 2. No 3. Unknown	Code 3
37. Crossing Illuminated by Street Lights or Special Lights 1. Yes 2. No 3. Unknown	Code 2		
38. Driver's Age 39. Driver's Gender 1. Male 2. Female	Code	40. Driver Drove Behind or in Front of Train and Struck or was Struck by Second Train 1. Yes 2. No 3. Unknown	Code 2
41. Driver 1. Drove around or thru the gate 4. Stopped on crossing 2. Stopped and then proceeded 5. Other (specify) 3. Did not stop	Code 5		
42. Driver Passed Standing Highway Vehicle 1. Yes 2. No 3. Unknown	Code 2	43. View of Track Obscured by (primary obstruction) 1. Permanent Structure 3. Passing Train 5. Vegetation 7. Other (specify) 2. Standing railroad equipment 4. Topography 6. Highway Vehicles 8. Not Obstructed	Code 8
Casualties to:	Killed	Injured	44. Driver was 1. Killed 2. Injured 3. Uninjured Code 3
45. Was Driver in the Vehicle? 1. Yes 2. No	Code 2		
46. Highway-Rail Crossing Users 0	0	47. Highway Vehicle Property Damage (est. dollar damage) \$2,000	48. Total Number of Highway-Rail Crossing Users (include driver) 0
49. Railroad Employees 0	0	50. Total Number of People on Train (include passengers and crew)	51. Is a Rail Equipment Accident / Incident Report Being Filed 1. Yes 2. No Code 2
52. Passengers on Train 0	0		
53a. Special Study Block	53b. Special Study Block		
54. Narrative Description			
55. Typed Name and Title	56. Signature		57. Date

FORM FRA F 6180.57

\* NOTE THAT ALL CASUALTIES MUST BE REPORTED ON FORM FRA F 6180.55A

Figure B-4. Crossing 073158N Accident Report – August 23, 1977 [44]

DEPARTMENT OF TRANSPORTATION FEDERAL RAILROAD ADMINISTRATION (FRA)		HIGHWAY-RAIL GRADE CROSSING ACCIDENT/INCIDENT REPORT		OMB Approval No. 2130-0500	
1. Name of Reporting Railroad <b>BNSF Railway Company [BNSF]</b>		1a. Alphabetic Code <b>BNSF</b>		1b. Railroad Accident/Incident No. <b>NE0313200</b>	
2. Name of Other Railroad or Other Entity Filing for Equipment Involved in Train Accident/Incident		2a. Alphabetic Code		2b. Railroad Accident/Incident No.	
3. Name of Railroad or Other Entity Responsible for Track Maintenance <i>(single entry)</i> <b>BNSF Railway Company [BNSF]</b>		3a. Alphabetic Code <b>BNSF</b>		3b. Railroad Accident/Incident No. <b>NE0313200</b>	
4. U.S. DOT Grade Crossing ID No. <b>083312L</b>		5. Date of Accident/Incident month   day   year <b>0   3   0   4   2013</b>		6. Time of Accident/Incident <b>2:40</b> AM <input type="checkbox"/> PM <input checked="" type="checkbox"/>	
7. Nearest Railroad Station <b>TECUMSEH</b>		8. Subdivision <b>ST JOSEPH</b>		9. County <b>JOHNSON</b>	
10. State Abbr. <b>NE</b> Code <b>31</b>		11. City <i>(if in a city)</i>		12. Highway Name or No. <b>3RD STREET</b> Public <input checked="" type="checkbox"/> Private <input type="checkbox"/>	
Highway User Involved			Rail Equipment Involved		
13. Type C. Truck-trailer F. Bus J. Other Motor Vehicle A. Auto D. Pick-up truck G. School Bus K. Pedestrian B. Truck E. Van H. Motorcycle M. Other <i>(specify)</i> Code <b>C</b>			17. Equipment 1. Train <i>(units pulling)</i> 5. Car(s) <i>(standing)</i> A. Train pulling- RCL 2. Train <i>(units pushing)</i> 6. Light loco(s) <i>(moving)</i> B. Train pushing- RCL 3. Train <i>(standing)</i> 7. Light loco(s) <i>(standing)</i> C. Train standing- RCL 8. Other <i>(specify)</i> 8. DMU Locomotive(s) Code <b>1</b>		
14. Vehicle Speed <i>(est. mph at impact)</i> <b>0</b> 15. Direction <i>(geographical)</i> Code <b>1</b> 1. North 2. South 3. East 4. West			18. Position of Car Unit in Train <b>1</b>		
16. Position 1. Stalled or stuck on crossing 4. Trapped on crossing by traffic 2. Stopped on Crossing 5. Blocked on crossing by gates Code <b>1</b> 3. Moving over crossing			19. Circumstance Code <b>1</b> 1. Rail equipment struck highway user 2. Rail equipment struck by highway user		
20a. Was the highway user and/or rail equipment involved in the impact transporting hazardous materials? 1. Highway User 2. Rail Equipment 3. Both 4. Neither Code <b>4</b>			20b. Was there a hazardous materials release by 1. Highway User 2. Rail Equipment 3. Both 4. Neither Code <b>4</b>		
20c. State here the name and quantity of the hazardous material released, if any					
21. Temperature <i>(specify if minus)</i> <b>38</b> °F		22. Visibility <i>(single entry)</i> Code <b>2</b> 1. Dawn 2. Day 3. Dusk 4. Dark		23. Weather <i>(single entry)</i> Code <b>1</b> 1. Clear 2. Cloudy 3. Rain 4. Fog 5. Sleet 6. Snow	
24. Type of Equipment Consist <i>(single entry)</i> 1. Freight Train 5. Single Car 9. Maint./inspect. car D. EMU 2. Passenger Train-Pulling 6. Cut of cars A. Spec. MoW Equip. E. DMU 3. Commuter Train-Pulling 7. Yard/Switching B. Passenger Train-Pushing 4. Work Train 8. Light loco(s) C. Commuter Train-Pushing Code <b>1</b>			25. Track Type Used by Rail Equipment Involved Code <b>1</b> 1. Main 2. Yard 3. Siding 4. Industry		26. Track Number or Name <b>SINGLE MAIN</b>
27. FRA Track Class (1-9,X) <b>4</b>		28. Number of Locomotive Units <b>4</b>	29. Number of Cars <b>149</b>	30. Consist Speed <i>(Recorded speed if available)</i> Code <b>R</b> R. Recorded <b>42 mph</b> E. Estimated	31. Time Table Direction Code <b>3</b> 1. North 3. East 2. South 4. West
32. Type of Crossing Warning 1. Gates 4. Wig wags 7. Crossbucks 10. Flagged by crew 2. Cantilever FLS 5. Hwy. traffic signals 8. Stop signs 11. Other <i>(specify)</i> 3. Standard FLS 6. Audible 9. Watchman 12. None Code(s) <b>01 03</b>			33. Signaled Crossing Warning <i>(See reverse side for instructions and codes)</i> Code <b>1</b>		34. Roadway Conditions Code <b>E</b> A. Dry B. Wet C. Snow/Slush D. Ice E. Sand/Mud/Dirt/Oil/Gravel F. Water (Standing, Moving)
35. Location of Warning 1. Both Sides 2. Side of Vehicle Approach 3. Opposite Side of Vehicle Approach Code <b>1</b>			36. Crossing Warning Interconnected with Highway Signals Code 1. Yes 2. No 3. Unknown		37. Crossing Illuminated by Street Lights or Special Lights Code <b>2</b> 1. Yes 2. No 3. Unknown
38. Highway User's Age <b>21</b>	39. Highway User's Gender 1. Male 2. Female Code <b>1</b>	40. Highway User Went Behind or in Front of Train and Struck or was Struck by Second Train Code <b>2</b> 1. Yes 2. No 3. Unknown		41. Highway User 1. Went around the gate 2. Stopped and then proceeded 3. Did not stop 4. Stopped on crossing 5. Other <i>(specify)</i> 6. Went around/thru temporary barricade 7. Went thru the gate 8. Suicide/Attempted suicide Code <b>5</b>	
42. Driver Passed Standing Highway Vehicle Code <b>2</b> 1. Yes 2. No 3. Unknown			43. View of Track Obscured by <i>(primary obstruction)</i> Code <b>8</b> 1. Permanent Structure 3. Passing Train 5. Vegetation 7. Other <i>(specify)</i> 2. Standing railroad equipment 4. Topography 6. Highway Vehicles 8. Not Obscured		
Casualties to:		Killed	Injured	44. Driver was Code <b>3</b> 1. Killed 2. Injured 3. Uninjured	
46. Highway-Rail Crossing Users		<b>0</b>	<b>0</b>	47. Highway Vehicle Property Damage <i>(est. dollar damage)</i> <b>\$5,000</b>	
49. Railroad Employees		<b>0</b>	<b>0</b>	48. Total Number of Vehicle Occupants <i>(including driver)</i> <b>0</b>	
52. Passengers on Train		<b>0</b>	<b>0</b>	50. Total Number of People on Train <i>(include passengers and train crew)</i> <b>3</b>	
53a. Special Study Block Video Taken? <input checked="" type="checkbox"/> Yes <input type="checkbox"/> No Video Used? <input checked="" type="checkbox"/> Yes <input type="checkbox"/> No			53b. Special Study Block		
54. Narrative Description <i>(Be specific, and continue on separate sheet if necessary)</i> 41: STUCK ON CROSSING					
55. Typed Name and Title			56. Signature		57. Date

NOTE: This report is part of the reporting railroad's accident report pursuant to the accident reports statute and, as such shall not "be admitted as evidence or used for any purpose in any suit or action for damages growing out of any matter mentioned in said report..." 49 U.S.C. 20903. See 49 C.F.R. 225.7 (b).  
FORM FRA F 6180.57 (Rev. 08/10) \* NOTE THAT ALL CASUALTIES MUST BE REPORTED ON FORM FRA F 6180.55A  
OMB approval expires 02/28/2014

Figure B-5. Crossing 083312L Accident Report – March 4, 2013 [44]

DEPARTMENT OF TRANSPORTATION FEDERAL RAILROAD ADMINISTRATION (FRA)		HIGHWAY-RAIL GRADE CROSSING ACCIDENT/INCIDENT REPORT			OMB Approval No. 2130-0500	
1. Name of Reporting Railroad <b>Burlington Northern Railroad Company [BN]</b>		1a. Alphabetic Code <b>BN</b>		1b. Railroad Accident/Incident No. <b>NE81</b>		
2. Name of Other Railroad or Other Entity Filing for Equipment Involved in Train Accident/Incident		2a. Alphabetic Code		2b. Railroad Accident/Incident No.		
3. Name of Railroad or Other Entity Responsible for Track Maintenance <i>(single entry)</i> <b>Burlington Northern Railroad Company [BN]</b>		3a. Alphabetic Code <b>BN</b>		3b. Railroad Accident/Incident No. <b>NE81</b>		
4. U.S. DOT Grade Crossing ID No. <b>083312L</b>		5. Date of Accident/Incident month: <b>02</b> day: <b>05</b> year: <b>1978</b>		6. Time of Accident/Incident <b>11:25</b> AM <input checked="" type="checkbox"/> PM <input type="checkbox"/>		
7. Nearest Railroad Station <b>TECUMSEH</b>		8. Subdivision		9. County <b>JOHNSON</b>		10. State Abbr. <b>NE</b> Code <b>31</b>
11. City <i>(if in a city)</i> <b>TECUMSEH</b>		12. Highway Name or No. <b>THIRD STREET</b>		Public <input checked="" type="checkbox"/> Private <input type="checkbox"/>		
Highway User Involved				Rail Equipment Involved		
13. Type C. Truck-trailer F. Bus J. Other Motor Vehicle A. Auto D. Pick-up truck G. School Bus K. Pedestrian B. Truck E. Van H. Motorcycle M. Other <i>(specify)</i> Code <b>A</b>				17. Equipment 1. Train <i>(units pulling)</i> 5. Car(s) <i>(standing)</i> A. Train pulling- RCL 2. Train <i>(units pushing)</i> 6. Light loco(s) <i>(moving)</i> B. Train pushing- RCL 3. Train <i>(standing)</i> 7. Light loco(s) <i>(standing)</i> C. Train standing- RCL 8. Other <i>(specify)</i> D. EMU Locomotive(s) E. DMU Locomotive(s) Code <b>1</b>		
14. Vehicle Speed <i>(est. mph at impact)</i> <b>20</b>		15. Direction <i>(geographical)</i> 1. North 2. South 3. East 4. West Code <b>2</b>		18. Position of Car Unit in Train <b>1</b>		
16. Position 1. Stalled or stuck on crossing 4. Trapped on crossing by traffic 2. Stopped on Crossing 5. Blocked on crossing by gates 3. Moving over crossing Code <b>3</b>		19. Circumstance 1. Rail equipment struck highway user 2. Rail equipment struck by highway user Code <b>1</b>				
20a. Was the highway user and/or rail equipment involved in the impact transporting hazardous materials? 1. Highway User 2. Rail Equipment 3. Both 4. Neither Code <b>4</b>		20b. Was there a hazardous materials release by 1. Highway User 2. Rail Equipment 3. Both 4. Neither Code				
20c. State here the name and quantity of the hazardous material released, if any						
21. Temperature <i>(specify if minus)</i> <b>9</b> °F		22. Visibility <i>(single entry)</i> 1. Dawn 2. Day 3. Dusk 4. Dark Code <b>2</b>		23. Weather <i>(single entry)</i> 1. Clear 2. Cloudy 3. Rain 4. Fog 5. Sleet 6. Snow Code <b>2</b>		
24. Type of Equipment Consist <i>(single entry)</i> 1. Freight Train 5. Single Car 9. Maint./inspect. car D. EMU 2. Passenger Train-Pulling 6. Cut of cars A. Spec. MoW Equip. E. DMU 3. Commuter Train-Pulling 7. Yard/Switching B. Passenger Train-Pushing 4. Work Train 8. Light loco(s) C. Commuter Train-Pushing Code <b>1</b>		25. Track Type Used by Rail Equipment Involved 1. Main 2. Yard 3. Siding 4. Industry Code <b>1</b>		26. Track Number or Name <b>SINGLE MAIN TRACK</b>		
27. FRA Track Class (1-9,X) <b>4</b>	28. Number of Locomotive Units <b>5</b>	29. Number of Cars <b>75</b>	30. Consist Speed <i>(Recorded speed if available)</i> R. Recorded <b>35</b> mph E. Estimated Code <b>E</b>		31. Time Table Direction 1. North 3. East 2. South 4. West Code <b>4</b>	
32. Type of Crossing Warning 1. Gates 4. Wig wags 7. Crossbucks 10. Flagged by crew 2. Cantilever FLS 5. Hwy. traffic signals 8. Stop signs 11. Other <i>(specify)</i> 3. Standard FLS 6. Audible 9. Watchman 12. None Code(s) <b>04</b>			33. Signaled Crossing Warning <i>(See reverse side for instructions and codes)</i> Code <b>1</b>		34. Roadway Conditions A. Dry B. Wet C. Snow/Slush D. Ice E. Sand/Mud/Dirt/Oil/Gravel F. Water (Standing, Moving) Code	
35. Location of Warning 1. Both Sides 2. Side of Vehicle Approach 3. Opposite Side of Vehicle Approach Code <b>2</b>		36. Crossing Warning Interconnected with Highway Signals 1. Yes 2. No 3. Unknown Code <b>2</b>		37. Crossing Illuminated by Street Lights or Special Lights 1. Yes 2. No 3. Unknown Code <b>2</b>		
38. Highway User's Age 1. Male 2. Female Code	39. Highway User's Gender 1. Male 2. Female Code		40. Highway User Went Behind or in Front of Train and Struck or was Struck by Second Train 1. Yes 2. No 3. Unknown Code <b>2</b>		41. Highway User 1. Went around the gate 5. Other <i>(specify)</i> 2. Stopped and then proceeded 6. Went around/thru temporary barricade 3. Did not stop 7. Went thru the gate 4. Stopped on crossing 8. Suicide/Attempted suicide Code <b>3</b>	
42. Driver Passed Standing Highway Vehicle 1. Yes 2. No 3. Unknown Code <b>2</b>		43. View of Track Obscured by <i>(primary obstruction)</i> 1. Permanent Structure 3. Passing Train 5. Vegetation 7. Other <i>(specify)</i> 2. Standing railroad equipment 4. Topography 6. Highway Vehicles 8. Not Obscured Code <b>8</b>		44. Driver was 1. Killed 2. Injured 3. Uninjured Code <b>3</b>		
46. Highway-Rail Crossing Users Killed <b>0</b> Injured <b>0</b>		47. Highway Vehicle Property Damage <i>(est. dollar damage)</i> <b>\$2,900</b>		45. Was Driver in the Vehicle? 1. Yes 2. No Code <b>1</b>		
49. Railroad Employees Killed <b>0</b> Injured <b>0</b>		50. Total Number of People on Train <i>(include passengers and train crew)</i>		48. Total Number of Vehicle Occupants <i>(including driver)</i> <b>1</b>		
52. Passengers on Train Killed <b>0</b> Injured <b>0</b>		51. Is a Rail Equipment Accident / Incident Report Being Filed 1. Yes 2. No Code <b>2</b>		53a. Special Study Block Video Taken? <input type="checkbox"/> Yes <input type="checkbox"/> No Video Used? <input type="checkbox"/> Yes <input type="checkbox"/> No		
53b. Special Study Block						
54. Narrative Description <i>(Be specific, and continue on separate sheet if necessary)</i>						
55. Typed Name and Title				56. Signature		57. Date

NOTE: This report is part of the reporting railroad's accident report pursuant to the accident reports statute and, as such shall not "be admitted as evidence or used for any purpose in any suit or action for damages growing out of any matter mentioned in said report..." 49 U.S.C. 20903. See 49 C.F.R. 225.7 (b).  
FORM FRA F 6180.57 (Rev. 08/10) \* NOTE THAT ALL CASUALTIES MUST BE REPORTED ON FORM FRA F 6180.55A  
OMB approval expires 02/28/2014

Figure B-6. Crossing 083312L Accident Report – February 5, 1978 [44]



DEPARTMENT OF TRANSPORTATION FEDERAL RAILROAD ADMINISTRATION (FRA)		HIGHWAY-RAIL GRADE CROSSING ACCIDENT/INCIDENT REPORT			OMB Approval No. 2130-0500	
1. Name of Reporting Railroad <b>Burlington Northern Railroad Company [BN]</b>		1a. Alphabetic Code <b>BN</b>		1b. Railroad Accident/Incident No. <b>LN47</b>		
2. Name of Other Railroad or Other Entity Filing for Equipment Involved in Train Accident/Incident		2a. Alphabetic Code		2b. Railroad Accident/Incident No.		
3. Name of Railroad or Other Entity Responsible for Track Maintenance <i>(single entry)</i> <b>Burlington Northern Railroad Company [BN]</b>		3a. Alphabetic Code <b>BN</b>		3b. Railroad Accident/Incident No. <b>LN47</b>		
4. U.S. DOT Grade Crossing ID No. <b>083312L</b>		5. Date of Accident/Incident month   day   year <b>0   1   4   1975</b>		6. Time of Accident/Incident <b>7:50</b> AM <input type="checkbox"/> PM <input checked="" type="checkbox"/>		
7. Nearest Railroad Station <b>ST MARY</b>		8. Subdivision		9. County <b>JOHNSON</b>		10. State Abbr. <b>NE</b> Code <b>31</b>
11. City <i>(if in a city)</i> <b>ST MARY</b>		12. Highway Name or No. <b>3RD STREET</b>		Public <input checked="" type="checkbox"/> Private <input type="checkbox"/>		
Highway User Involved				Rail Equipment Involved		
13. Type C. Truck-trailer F. Bus J. Other Motor Vehicle A. Auto D. Pick-up truck G. School Bus K. Pedestrian B. Truck E. Van H. Motorcycle M. Other <i>(specify)</i> Code <b>A</b>				17. Equipment 4. Car(s) <i>(moving)</i> A. Train pulling- RCL 1. Train <i>(units pulling)</i> 5. Car(s) <i>(standing)</i> B. Train pushing- RCL 2. Train <i>(units pushing)</i> 6. Light loco(s) <i>(moving)</i> C. Train standing- RCL 3. Train <i>(standing)</i> 7. Light loco(s) <i>(standing)</i> D. EMU Locomotive(s) 8. Other <i>(specify)</i> E. DMU Locomotive(s) Code <b>1</b>		
14. Vehicle Speed <i>(est. mph at impact)</i>		15. Direction <i>(geographical)</i> 1. North 2. South 3. East 4. West Code <b>2</b>		18. Position of Car Unit in Train <b>1</b>		
16. Position 1. Stalled or stuck on crossing 4. Trapped on crossing by traffic 2. Stopped on Crossing 5. Blocked on crossing by gates 3. Moving over crossing Code <b>3</b>		19. Circumstance 1. Rail equipment struck highway user 2. Rail equipment struck by highway user Code <b>2</b>				
20a. Was the highway user and/or rail equipment involved in the impact transporting hazardous materials? 1. Highway User 2. Rail Equipment 3. Both 4. Neither Code <b>4</b>		20b. Was there a hazardous materials release by 1. Highway User 2. Rail Equipment 3. Both 4. Neither Code				
20c. State here the name and quantity of the hazardous material released, if any						
21. Temperature <i>(specify if minus)</i> <b>21</b> °F		22. Visibility <i>(single entry)</i> 1. Dawn 2. Day 3. Dusk 4. Dark Code <b>4</b>		23. Weather <i>(single entry)</i> 1. Clear 2. Cloudy 3. Rain 4. Fog 5. Sleet 6. Snow Code <b>2</b>		
24. Type of Equipment Consist <i>(single entry)</i> 1. Freight Train 5. Single Car 9. Maint./inspect. car D. EMU 2. Passenger Train-Pulling 6. Cut of cars A. Spec. MoW Equip. E. DMU 3. Commuter Train-Pulling 7. Yard/Switching B. Passenger Train-Pushing 4. Work Train 8. Light loco(s) C. Commuter Train-Pushing Code <b>1</b>		25. Track Type Used by Rail Equipment Involved 1. Main 2. Yard 3. Siding 4. Industry Code <b>1</b>		26. Track Number or Name <b>MAIN TRACK</b>		
27. FRA Track Class (1-9,X) <b>4</b>		28. Number of Locomotive Units <b>2</b>		29. Number of Cars <b>69</b>		30. Consist Speed <i>(Recorded speed if available)</i> R. Recorded <b>35</b> mph E. Estimated Code <b>E</b>
31. Time Table Direction 1. North 3. East 2. South 4. West Code <b>3</b>		32. Type of Crossing Warning 1. Gates 4. Wig wags 7. Crossbucks 10. Flagged by crew 2. Cantilever FLS 5. Hwy. traffic signals 8. Stop signs 11. Other <i>(specify)</i> 3. Standard FLS 6. Audible 9. Watchman 12. None Code(s) <b>04</b>		33. Signaled Crossing Warning <i>(See reverse side for instructions and codes)</i> Code <b>1</b>		34. Roadway Conditions A. Dry B. Wet C. Snow/Slush D. Ice E. Sand/Mud/Dirt/Oil/Gravel F. Water (Standing, Moving) Code
35. Location of Warning 1. Both Sides 2. Side of Vehicle Approach 3. Opposite Side of Vehicle Approach Code <b>1</b>		36. Crossing Warning Interconnected with Highway Signals 1. Yes 2. No 3. Unknown Code <b>2</b>		37. Crossing Illuminated by Street Lights or Special Lights 1. Yes 2. No 3. Unknown Code <b>2</b>		
38. Highway User's Age 1. Male 2. Female Code <b>2</b>		39. Highway User's Gender 1. Male 2. Female Code <b>2</b>		40. Highway User Went Behind or in Front of Train and Struck or was Struck by Second Train 1. Yes 2. No 3. Unknown Code <b>2</b>		41. Highway User 1. Went around the gate 2. Stopped and then proceeded 3. Did not stop 4. Stopped on crossing 5. Other <i>(specify)</i> 6. Went around/thru temporary barricade 7. Went thru the gate 8. Suicide/Attempted suicide Code <b>3</b>
42. Driver Passed Standing Highway Vehicle 1. Yes 2. No 3. Unknown Code <b>2</b>		43. View of Track Obscured by <i>(primary obstruction)</i> 1. Permanent Structure 3. Passing Train 5. Vegetation 7. Other <i>(specify)</i> 2. Standing railroad equipment 4. Topography 6. Highway Vehicles 8. Not Obscured Code <b>8</b>		44. Driver was 1. Killed 2. Injured 3. Uninjured Code <b>3</b>		
45. Was Driver in the Vehicle? 1. Yes 2. No Code <b>1</b>		46. Highway-Rail Crossing Users Killed Injured <b>0 0</b>		47. Highway Vehicle Property Damage <i>(est. dollar damage)</i> <b>\$500</b>		
48. Total Number of Vehicle Occupants <i>(including driver)</i> <b>1</b>		49. Railroad Employees Killed Injured <b>0 0</b>		50. Total Number of People on Train <i>(include passengers and train crew)</i>		
51. Is a Rail Equipment Accident / Incident Report Being Filed 1. Yes 2. No Code <b>2</b>		52. Passengers on Train Killed Injured <b>0 0</b>		53a. Special Study Block Video Taken? <input type="checkbox"/> Yes <input type="checkbox"/> No Video Used? <input type="checkbox"/> Yes <input type="checkbox"/> No		
53b. Special Study Block		54. Narrative Description <i>(Be specific, and continue on separate sheet if necessary)</i>				
55. Typed Name and Title		56. Signature			57. Date	

NOTE: This report is part of the reporting railroad's accident report pursuant to the accident reports statute and, as such shall not "be admitted as evidence or used for any purpose in any suit or action for damages growing out of any matter mentioned in said report..." 49 U.S.C. 20903. See 49 C.F.R. 225.7 (b).

FORM FRA F 6180.57 (Rev. 08/10) \* NOTE THAT ALL CASUALTIES MUST BE REPORTED ON FORM FRA F 6180.55A  
OMB approval expires 02/28/2014

Figure B-7. Crossing 083312L Accident Report – January 14, 1975 [44]

**Appendix C. Accelerometer Data Plots, Test Nos. UTCRS-1 through UTCRS-4**

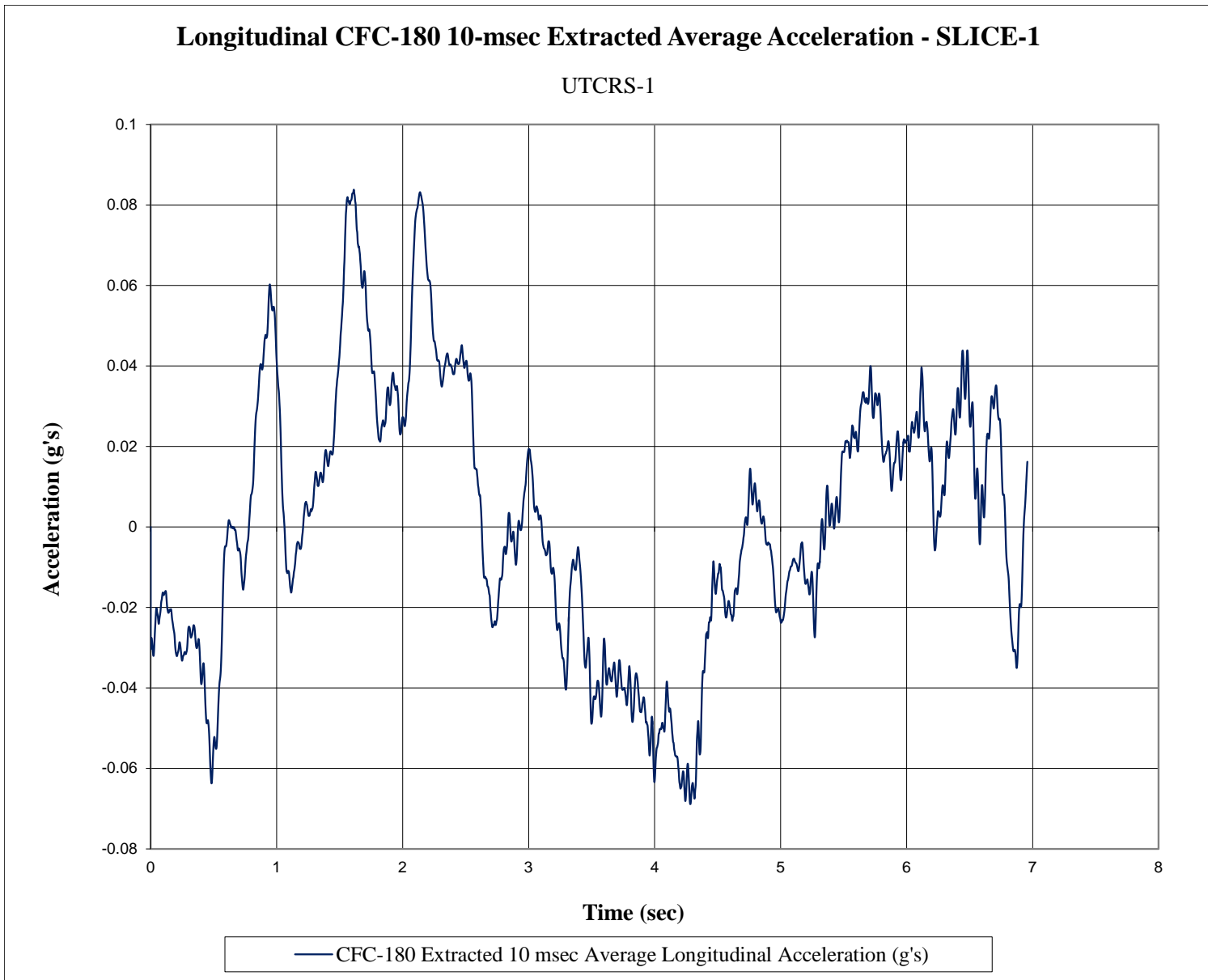

Figure C-1. 10-ms Average Longitudinal Acceleration (SLICE-1), Test No. UTCRS-1

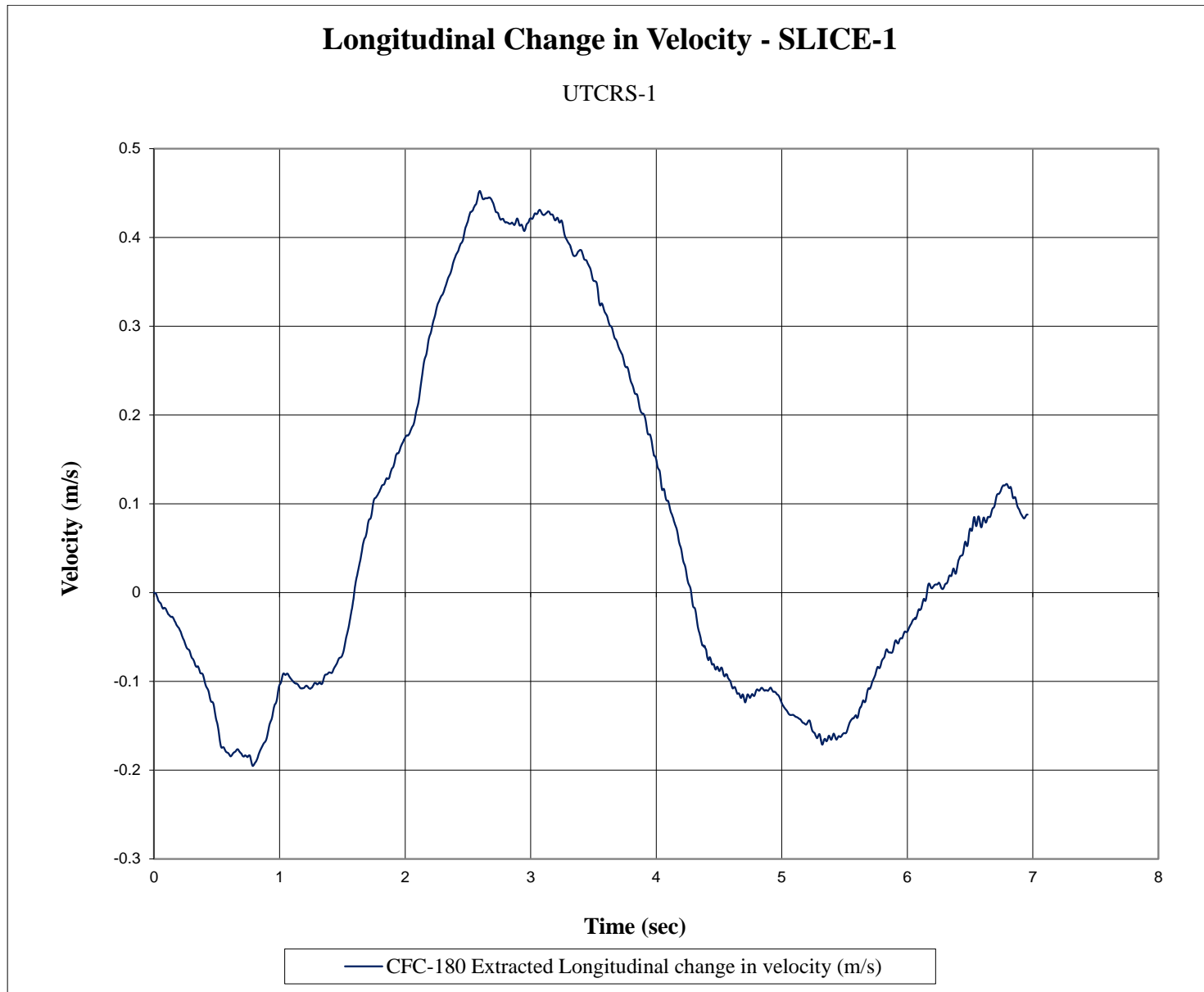

Figure C-2. Longitudinal Change in Velocity (SLICE-1), Test No. UTCRS-1

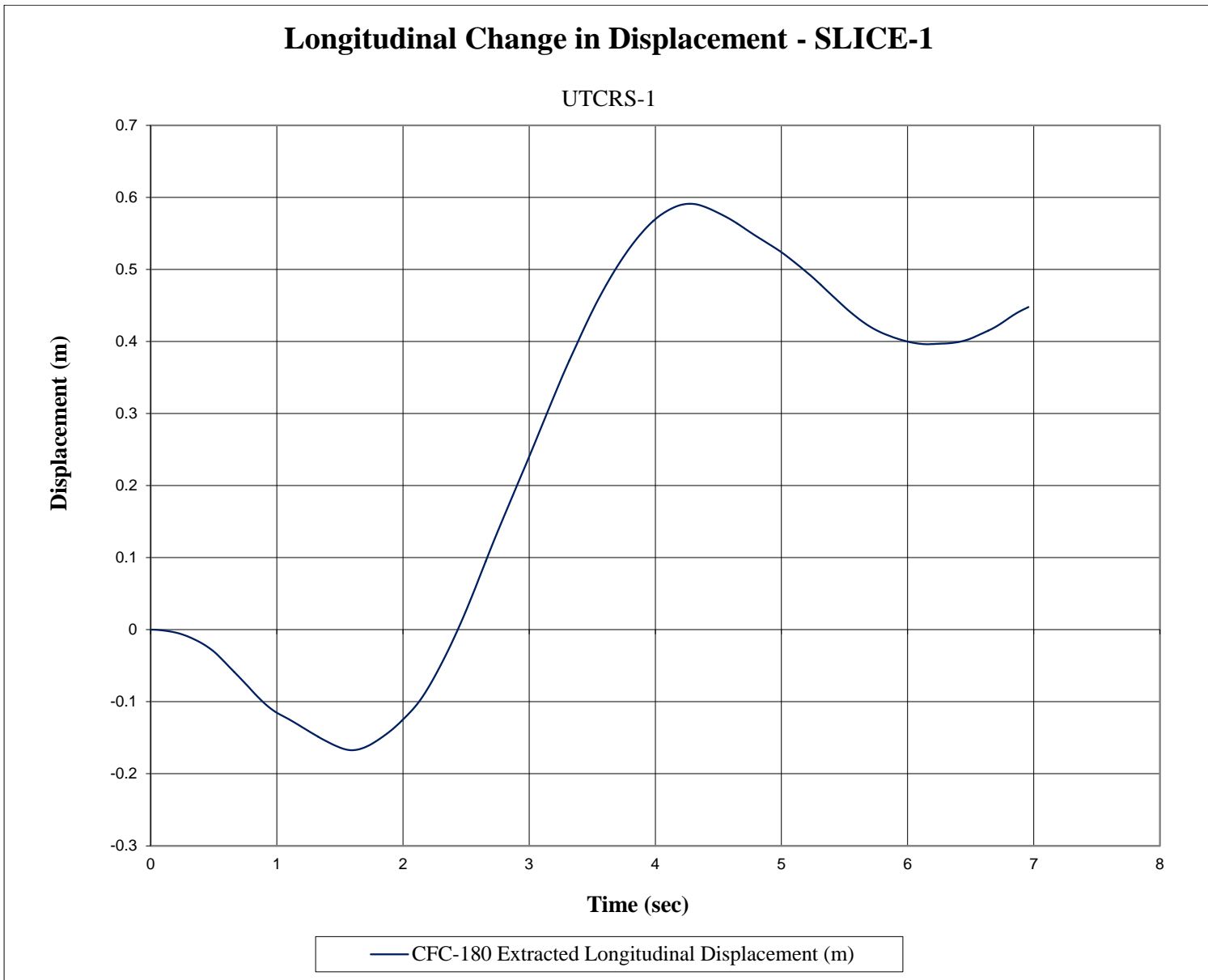

Figure C-3. Longitudinal Change in Displacement (SLICE-1), Test No. UTCRS-1

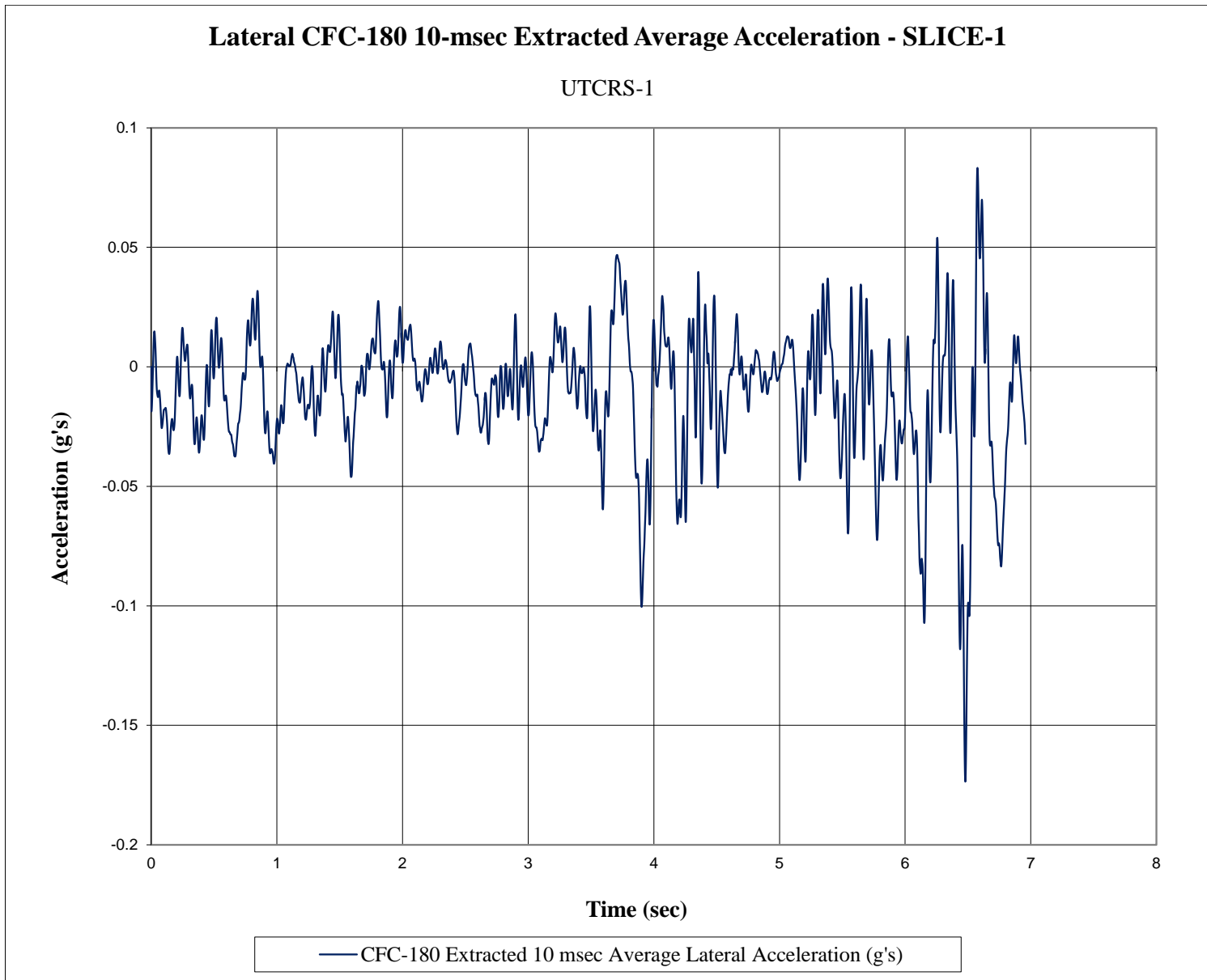

Figure C-4. 10-ms Average Lateral Acceleration (SLICE-1), Test No. UTCRS-1



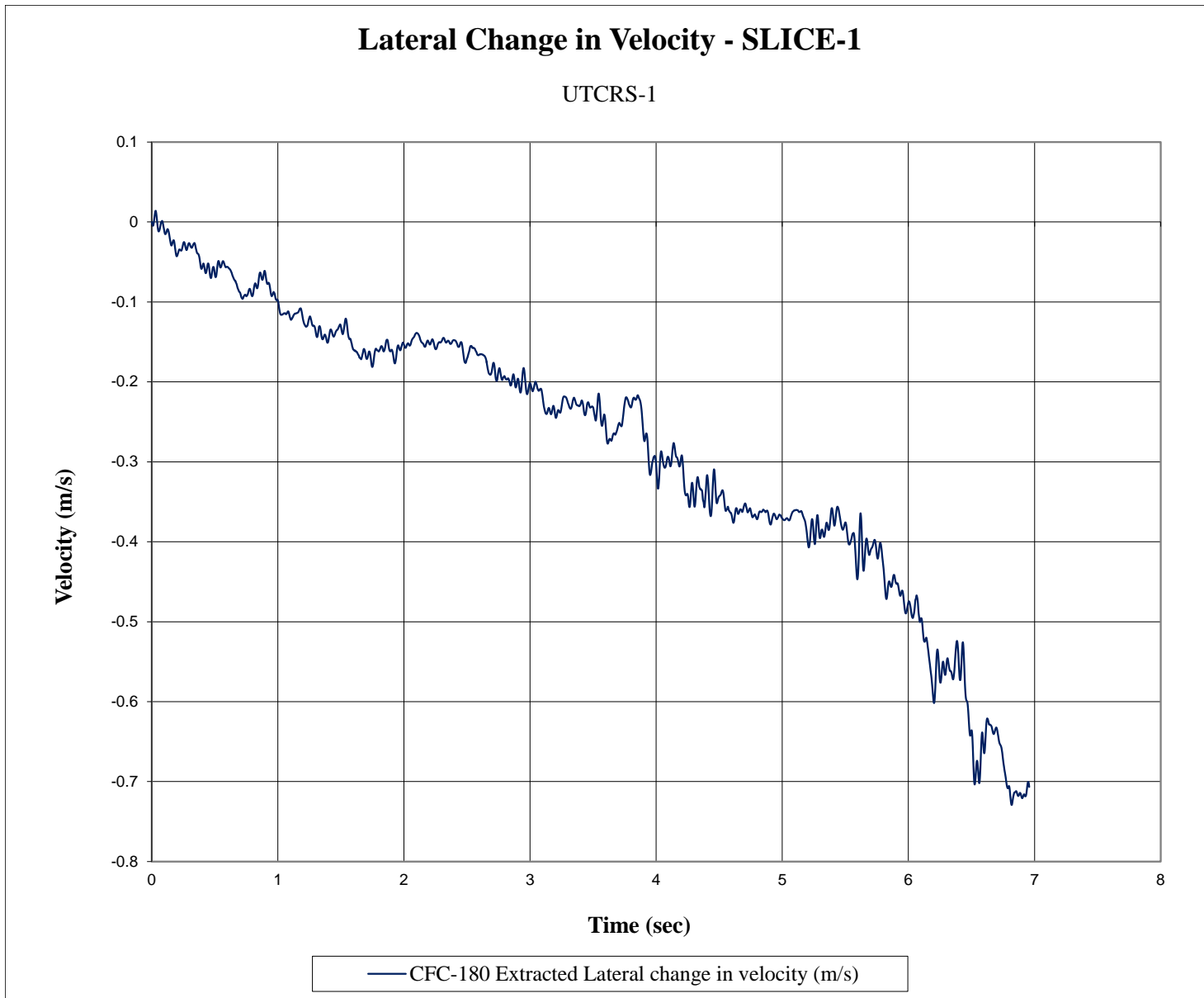

Figure C-5. Lateral Change in Velocity (SLICE-1), Test No. UTCRS-1

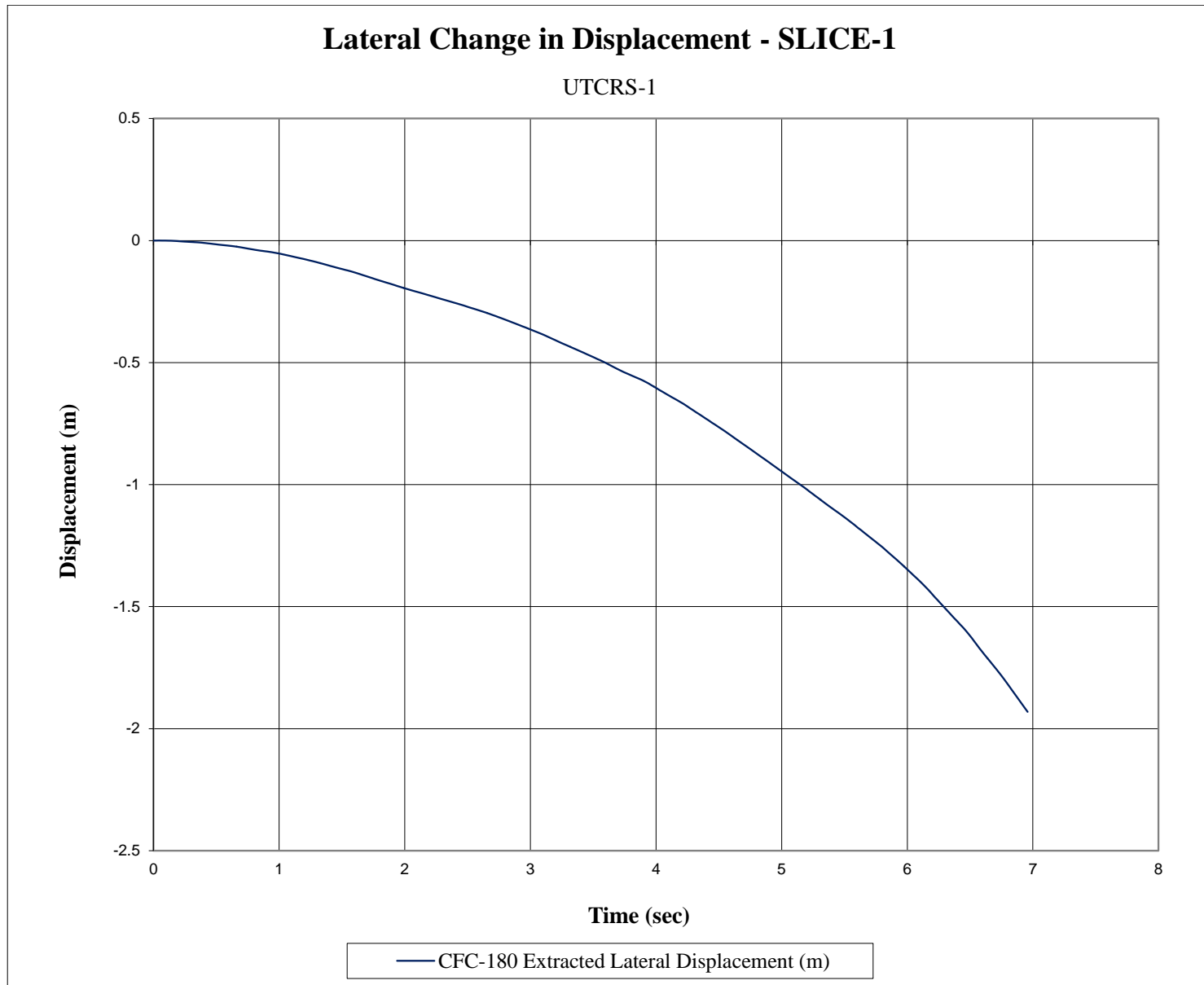

Figure C-6. Lateral Change in Displacement (SLICE-1), Test No. UTCRS-1

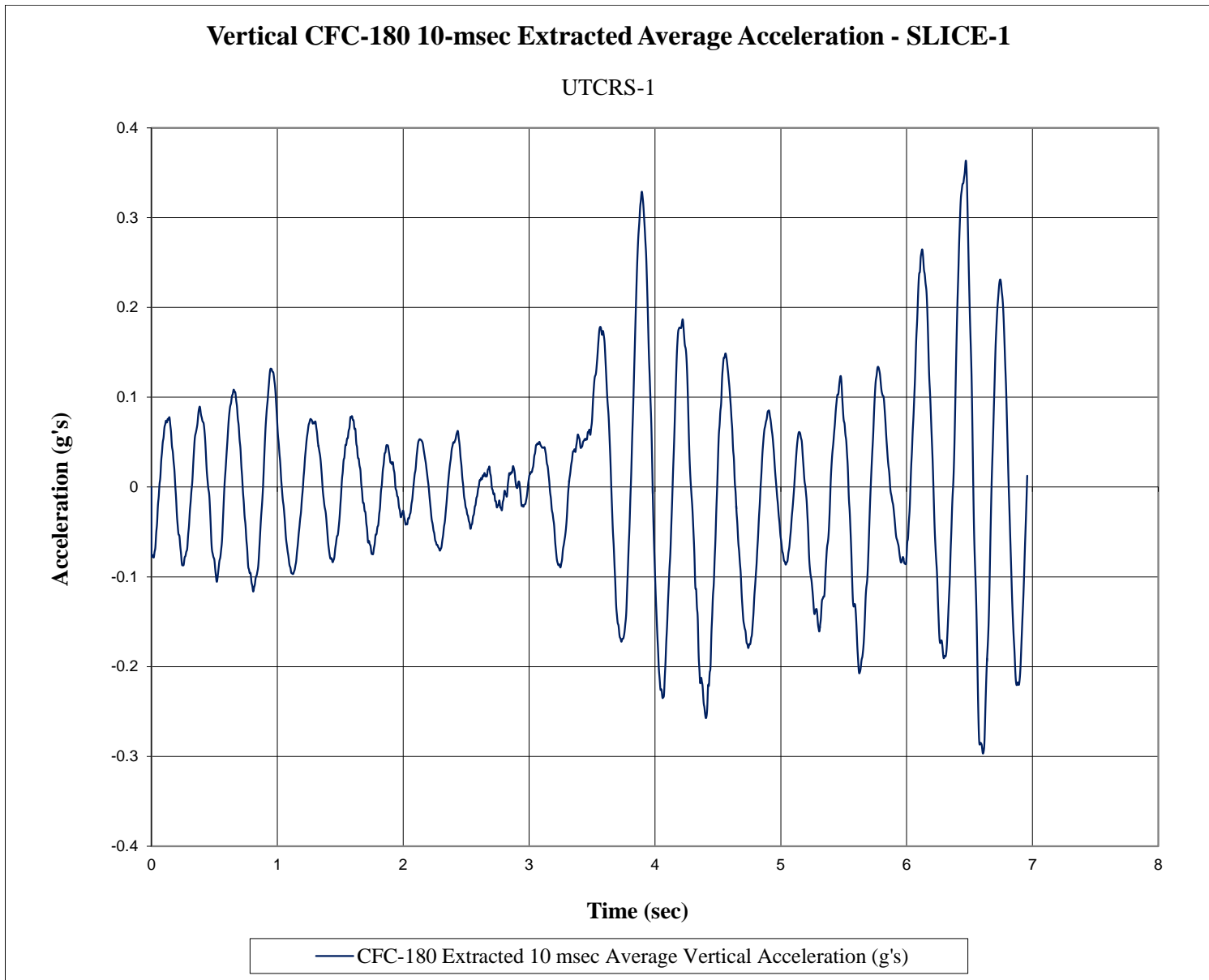

Figure C-7. 10-ms Average Vertical Acceleration (SLICE-1), Test No. UTCRS-1

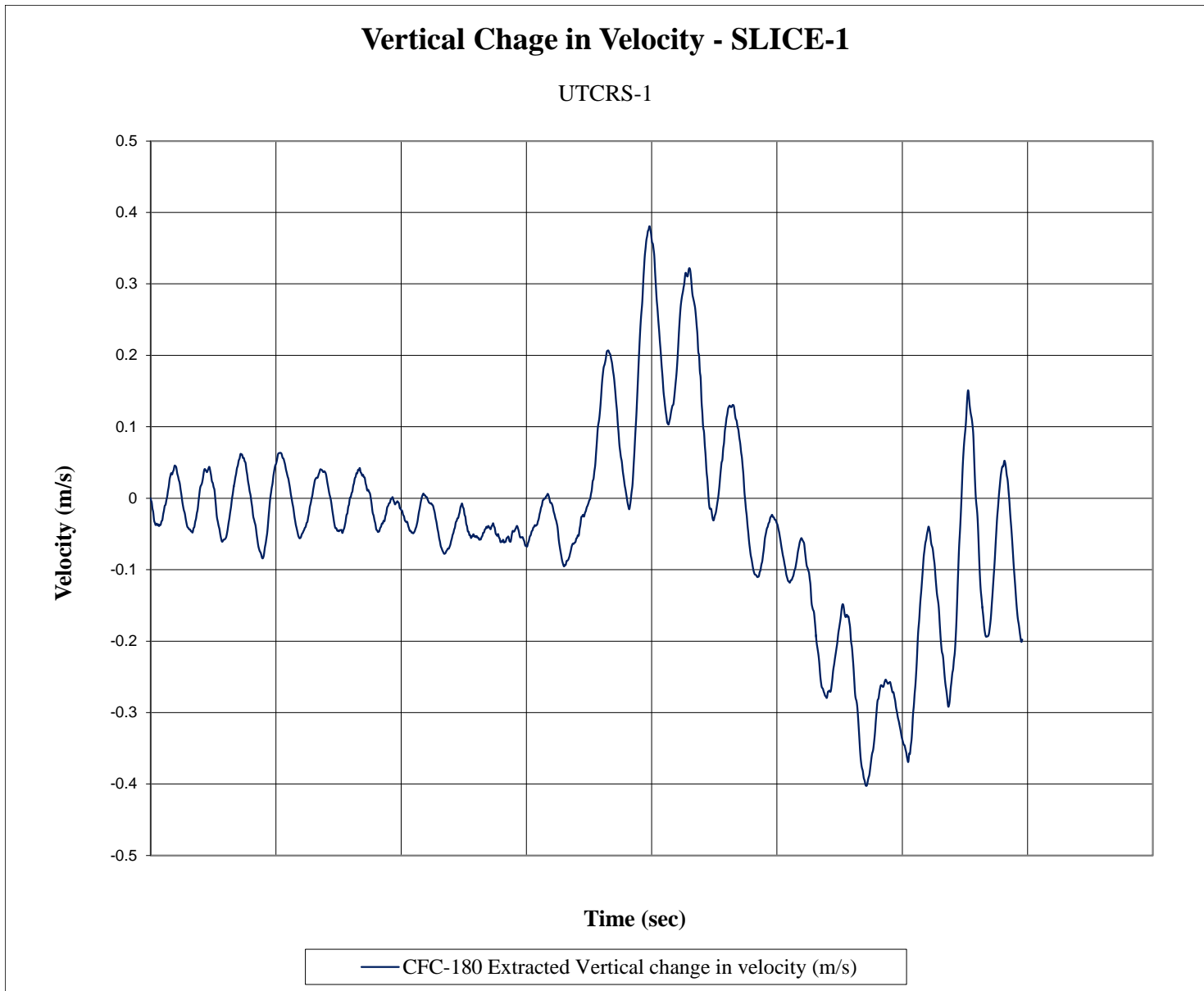

Figure C-8. Vertical Change in Velocity (SLICE-1), Test No. UTCRS-1

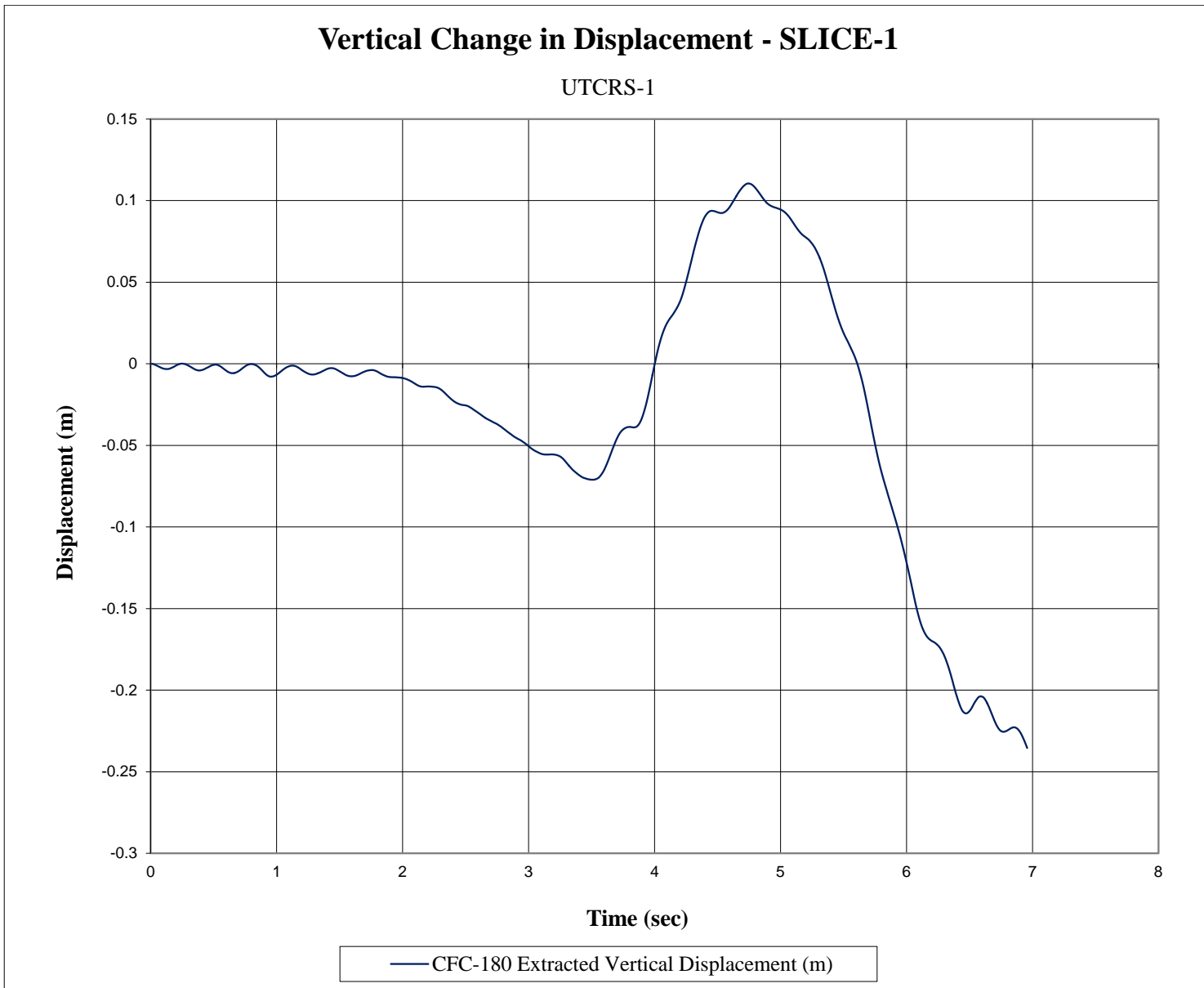

Figure C-9. Vertical Change in Displacement (SLICE-1), Test No. UTCRS-1

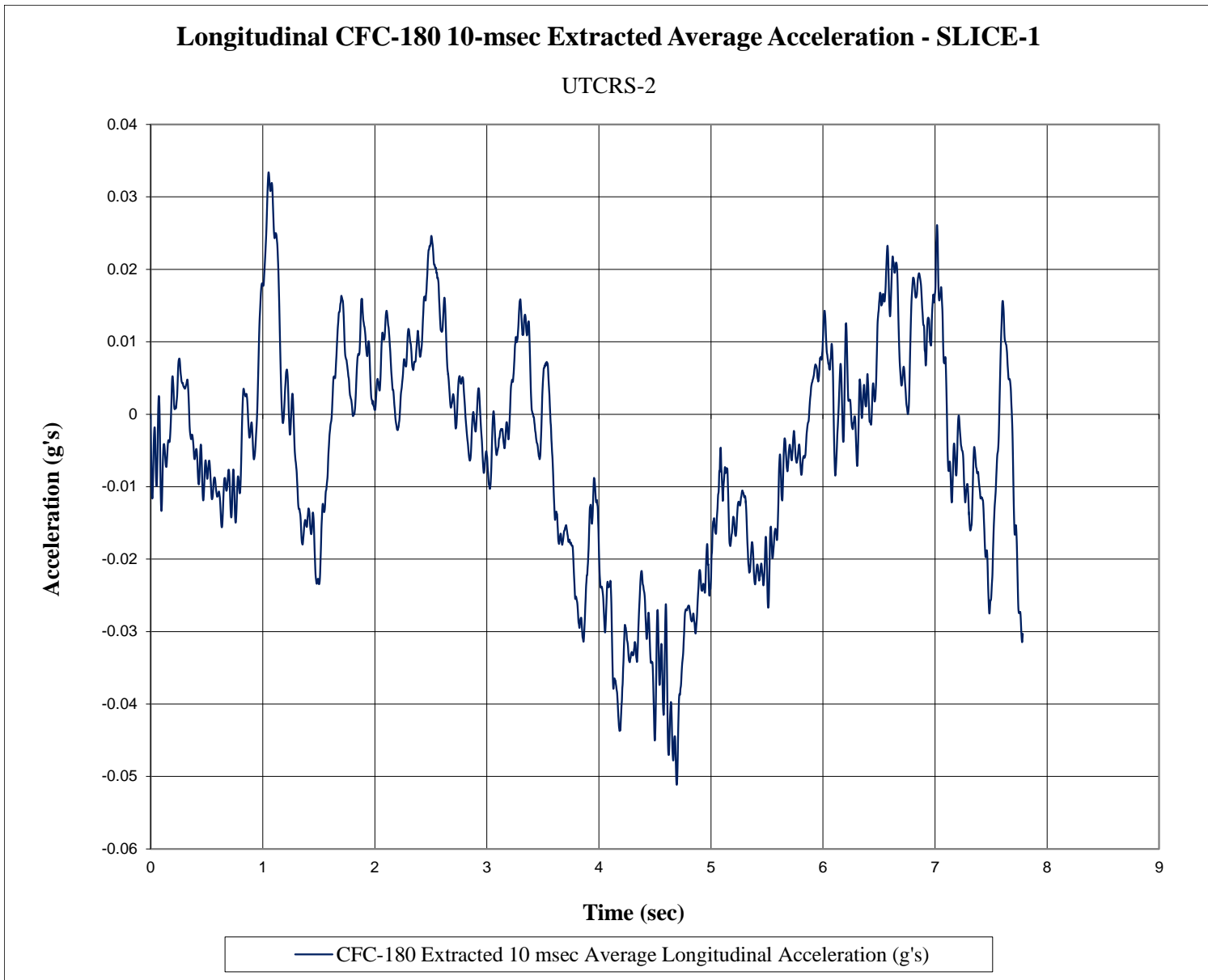

Figure C-10. 10-ms Average Longitudinal Acceleration (SLICE-1), Test No. UTCRS-2



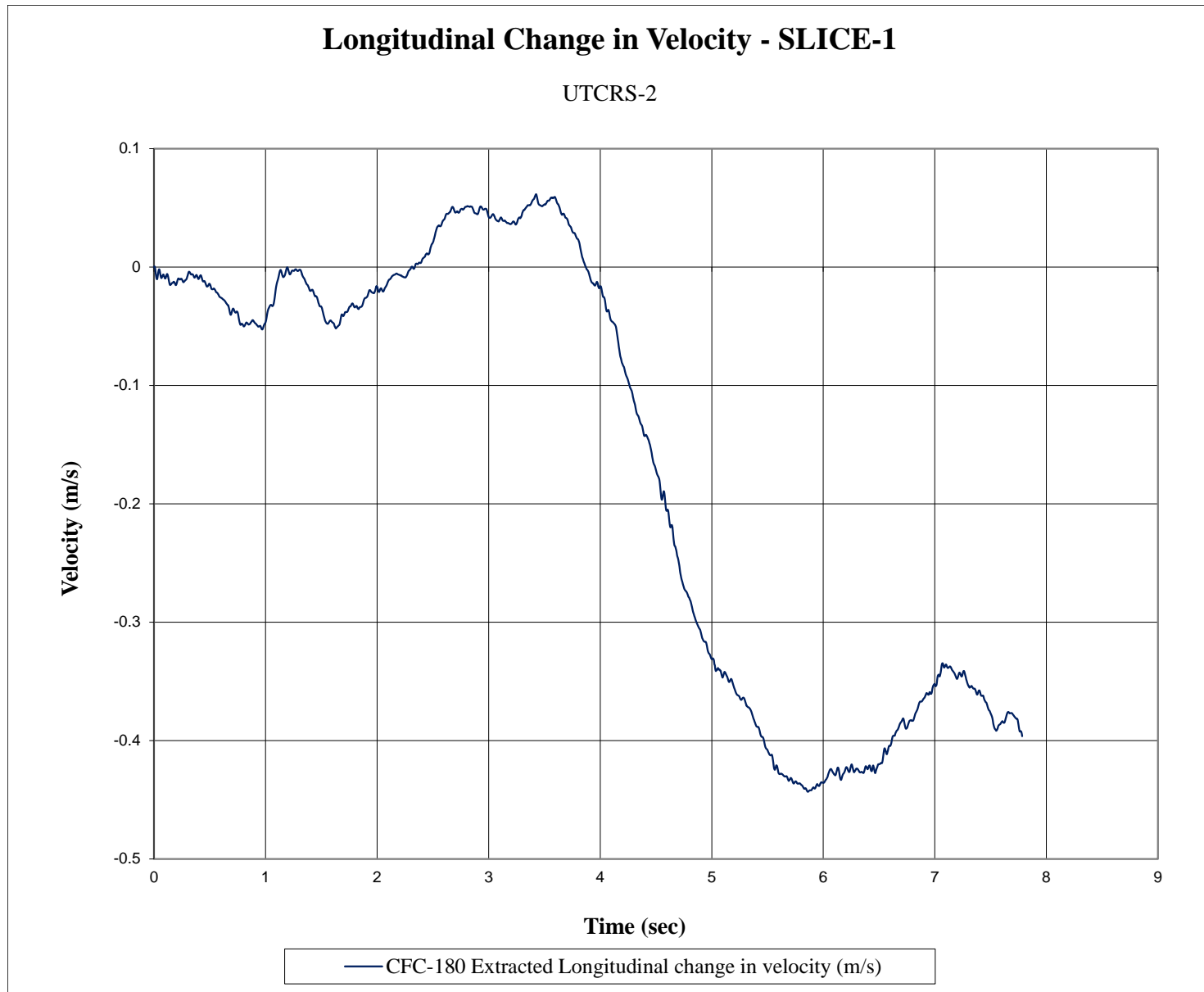

Figure C-11. Longitudinal Change in Velocity (SLICE-1), Test No. UTCRS-2

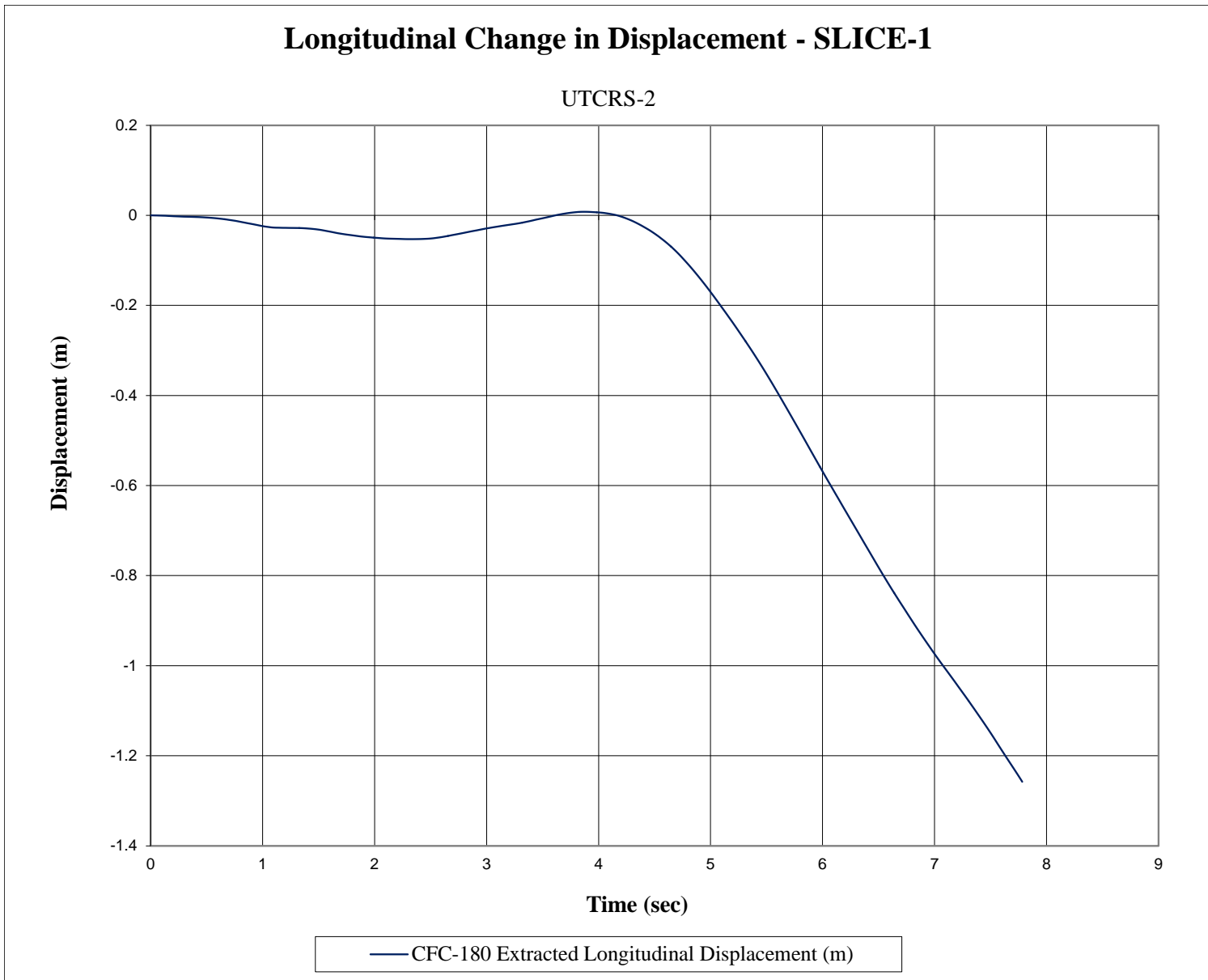

Figure C-12. Longitudinal Change in Displacement (SLICE-1), Test No. UTCRS-2

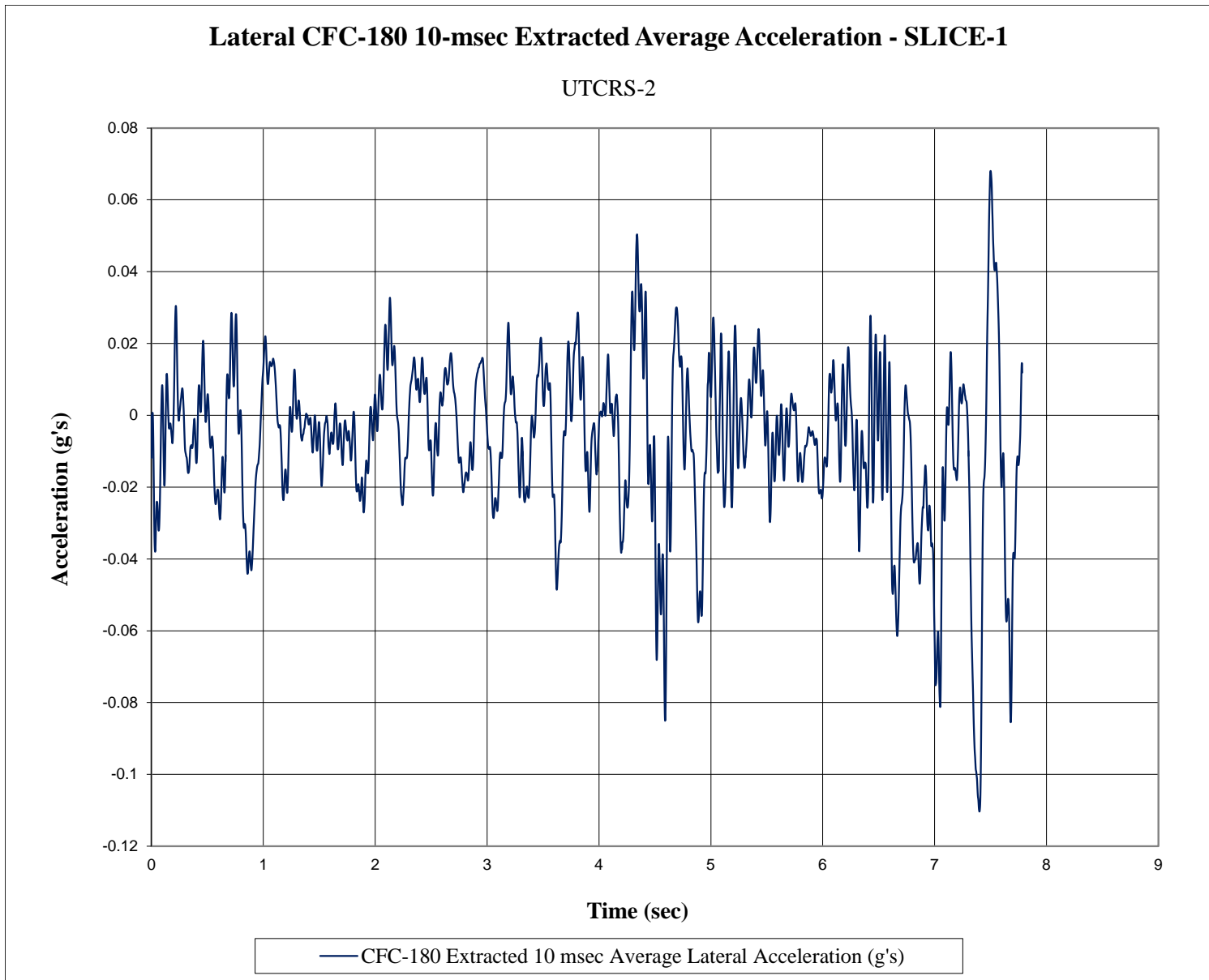

Figure C-13. 10-ms Average Lateral Acceleration (SLICE-1), Test No. UTCRS-2

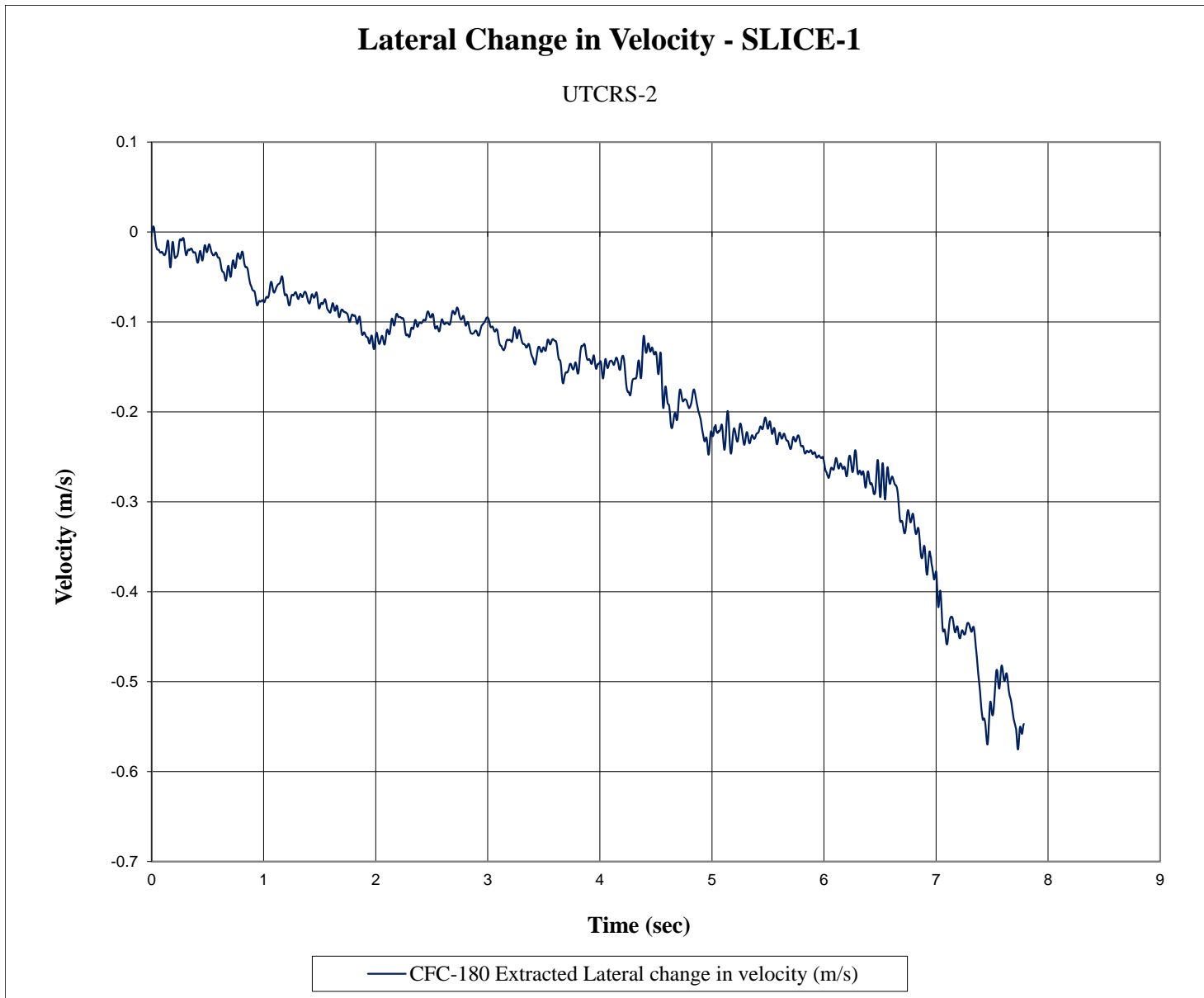

Figure C-14. Lateral Change in Velocity (SLICE-1), Test No. UTCRS-2

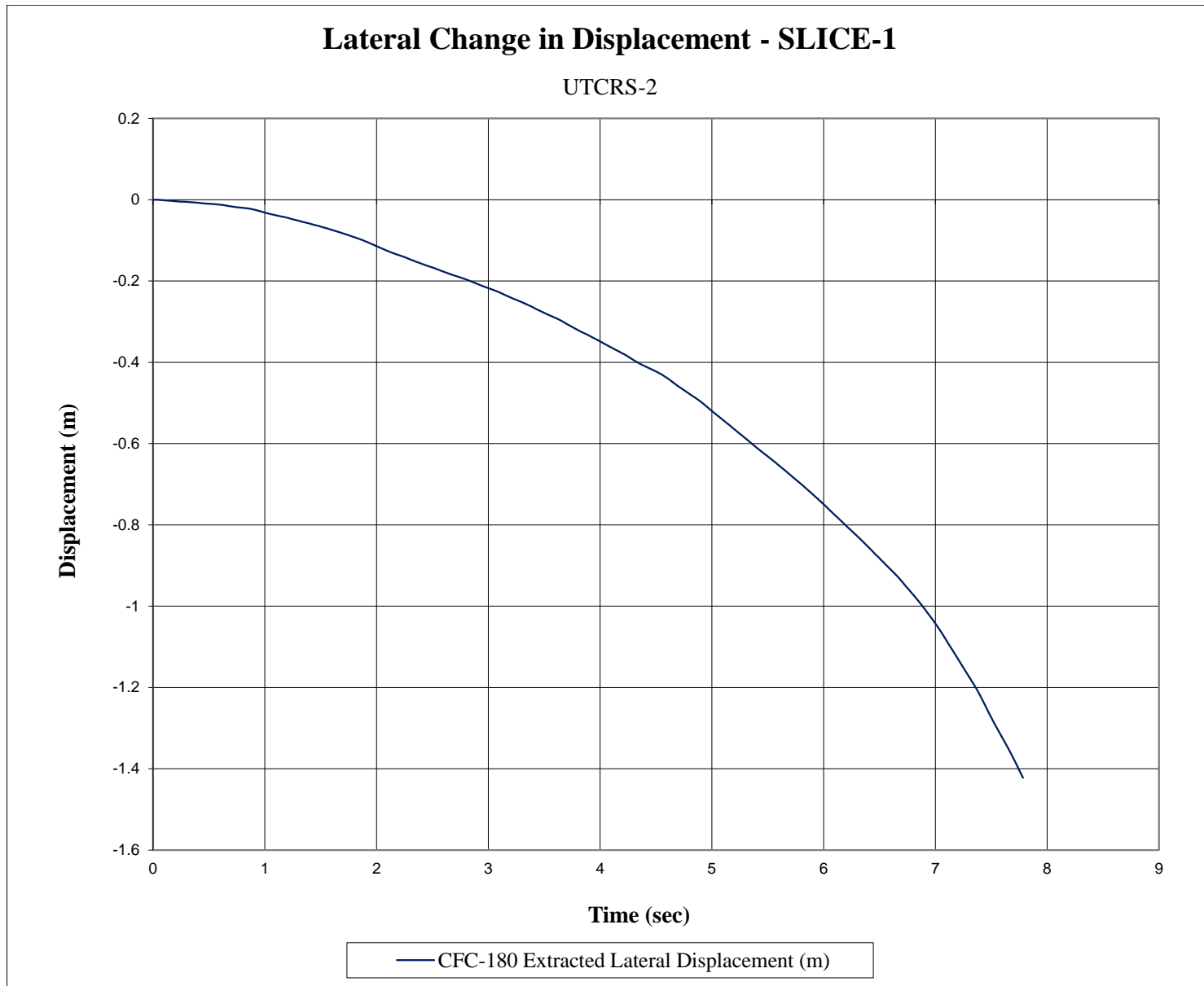

Figure C-15. Lateral Change in Displacement (SLICE-1), Test No. UTCRS-2

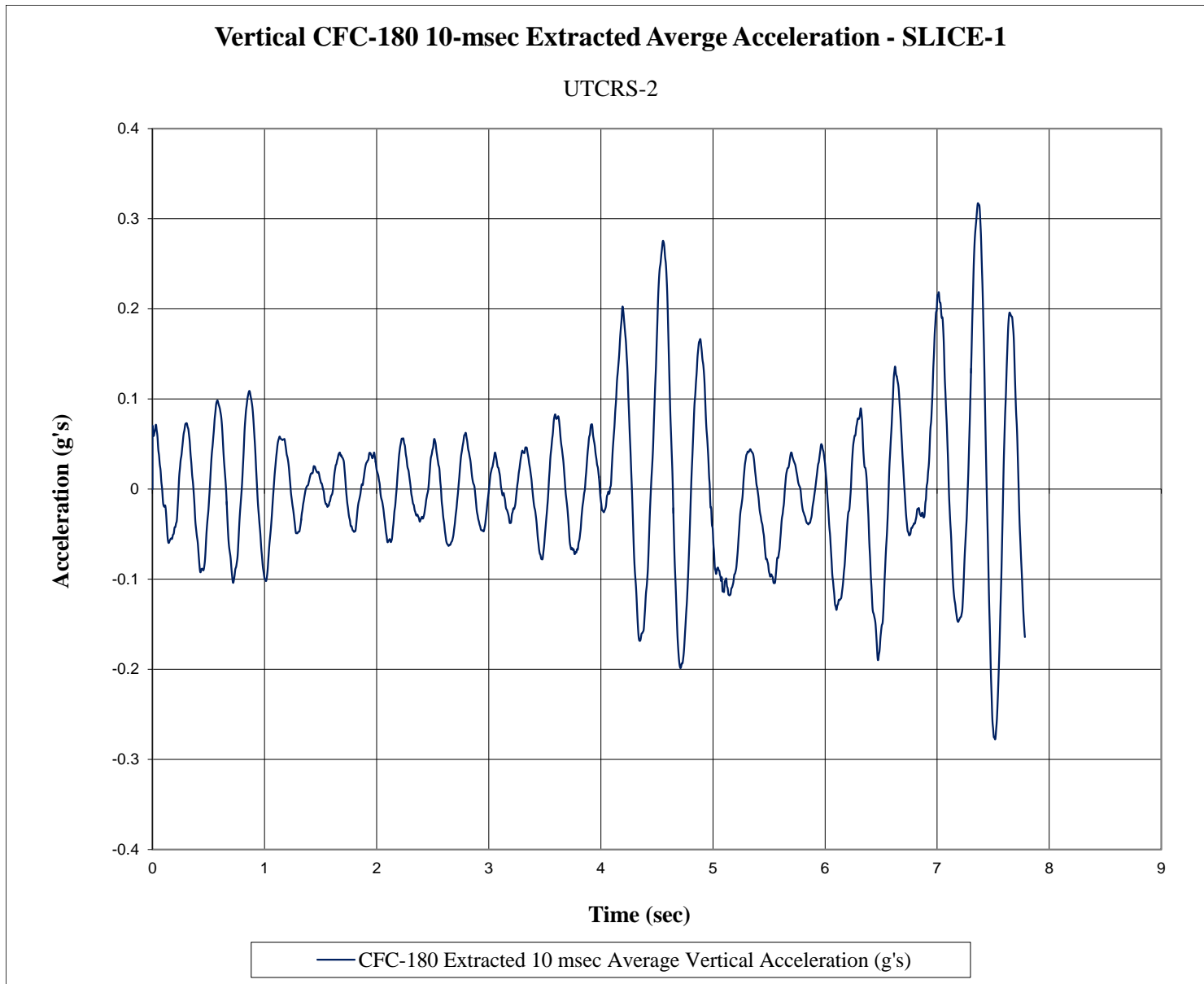

Figure C-16. 10-ms Average Vertical Acceleration (SLICE-1), Test No. UTCRS-2



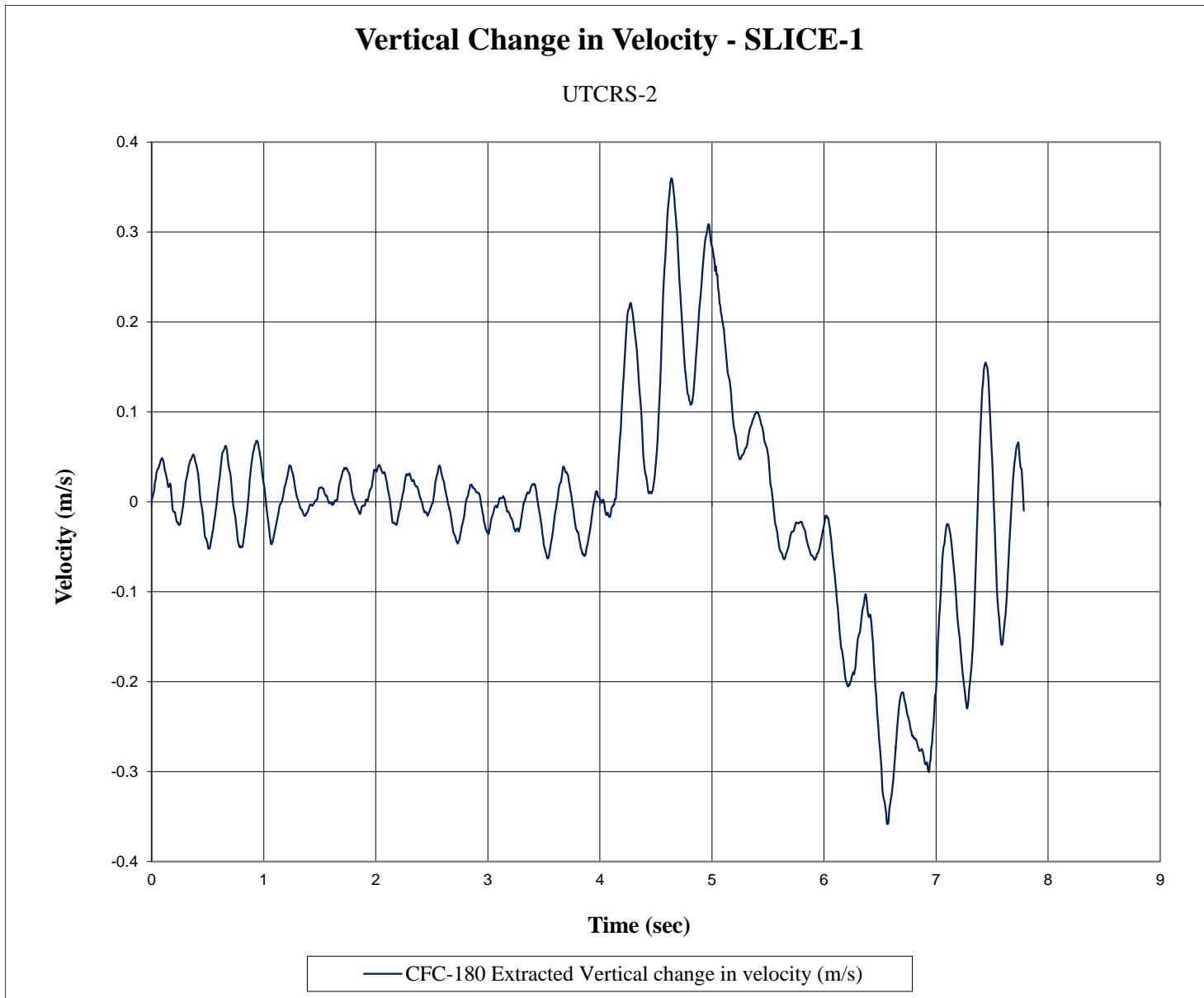

Figure C-17. Vertical Change in Velocity (SLICE-1), Test No. UTCRS-2

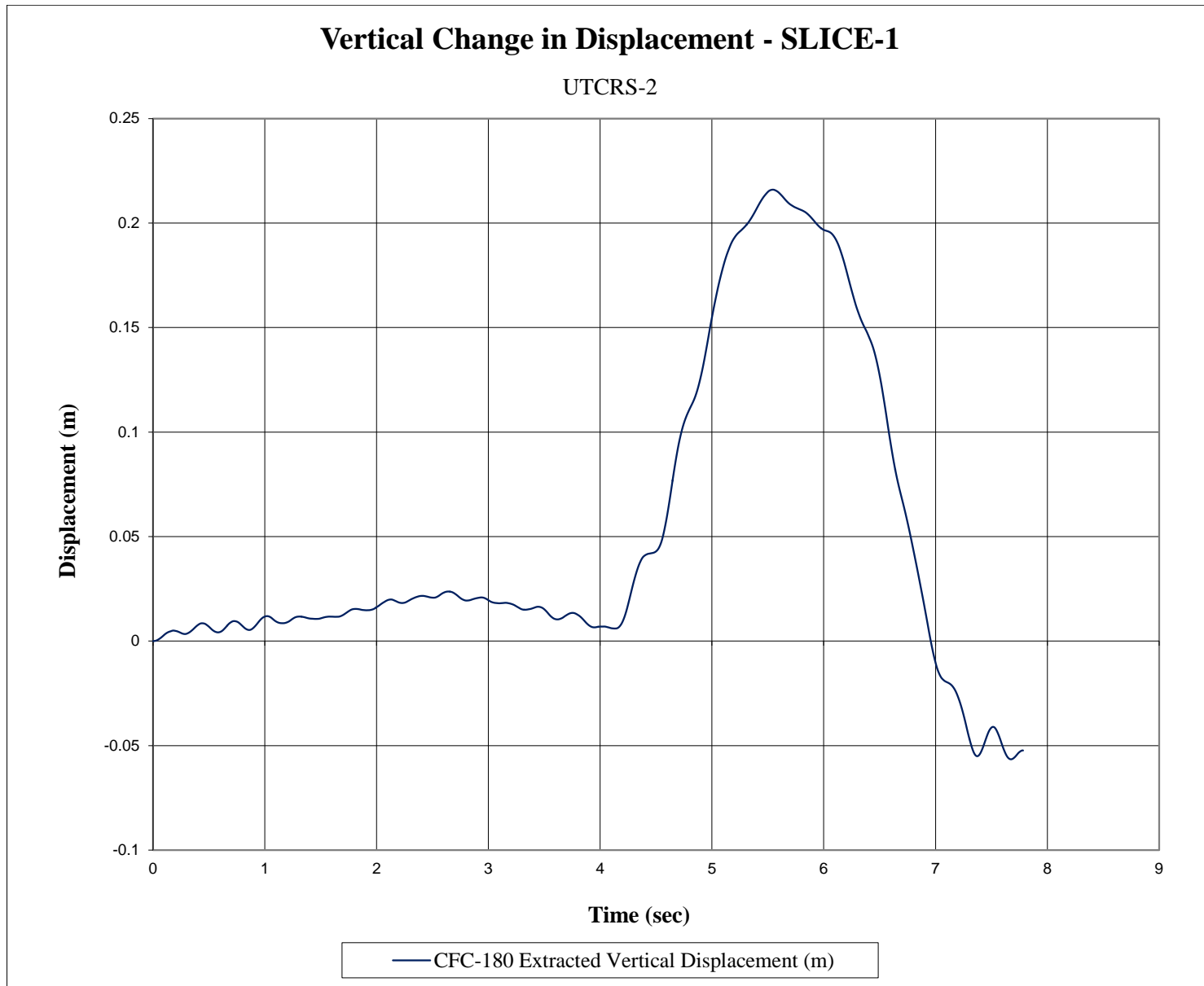

Figure C-18. Vertical Change in Displacement (SLICE-1), Test No. UTCRS-2

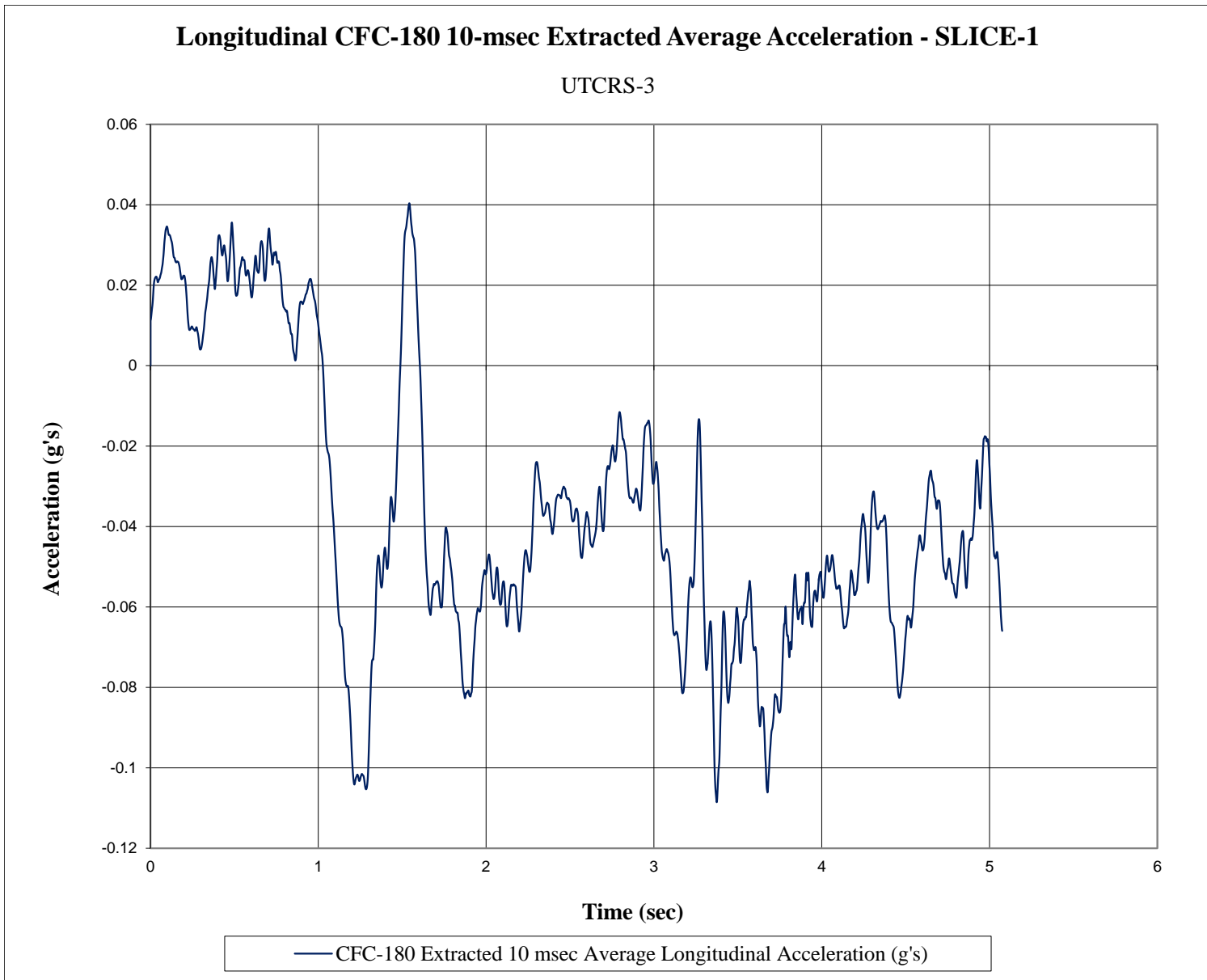

Figure C-19. 10-ms Average Longitudinal Acceleration (SLICE-1), Test No. UTCRS-3

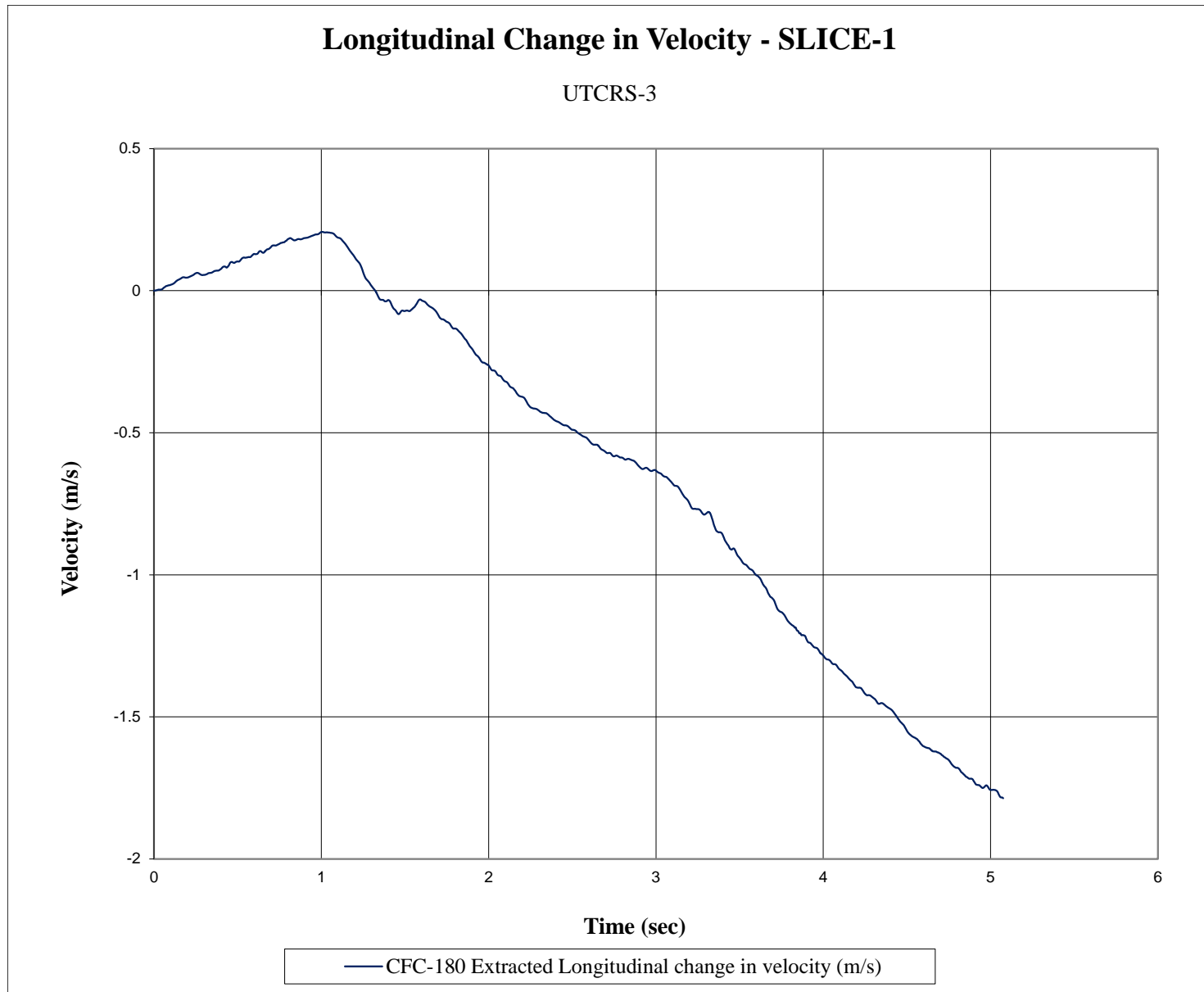

Figure C-20. Longitudinal Change in Velocity (SLICE-1), Test No. UTCRS-3

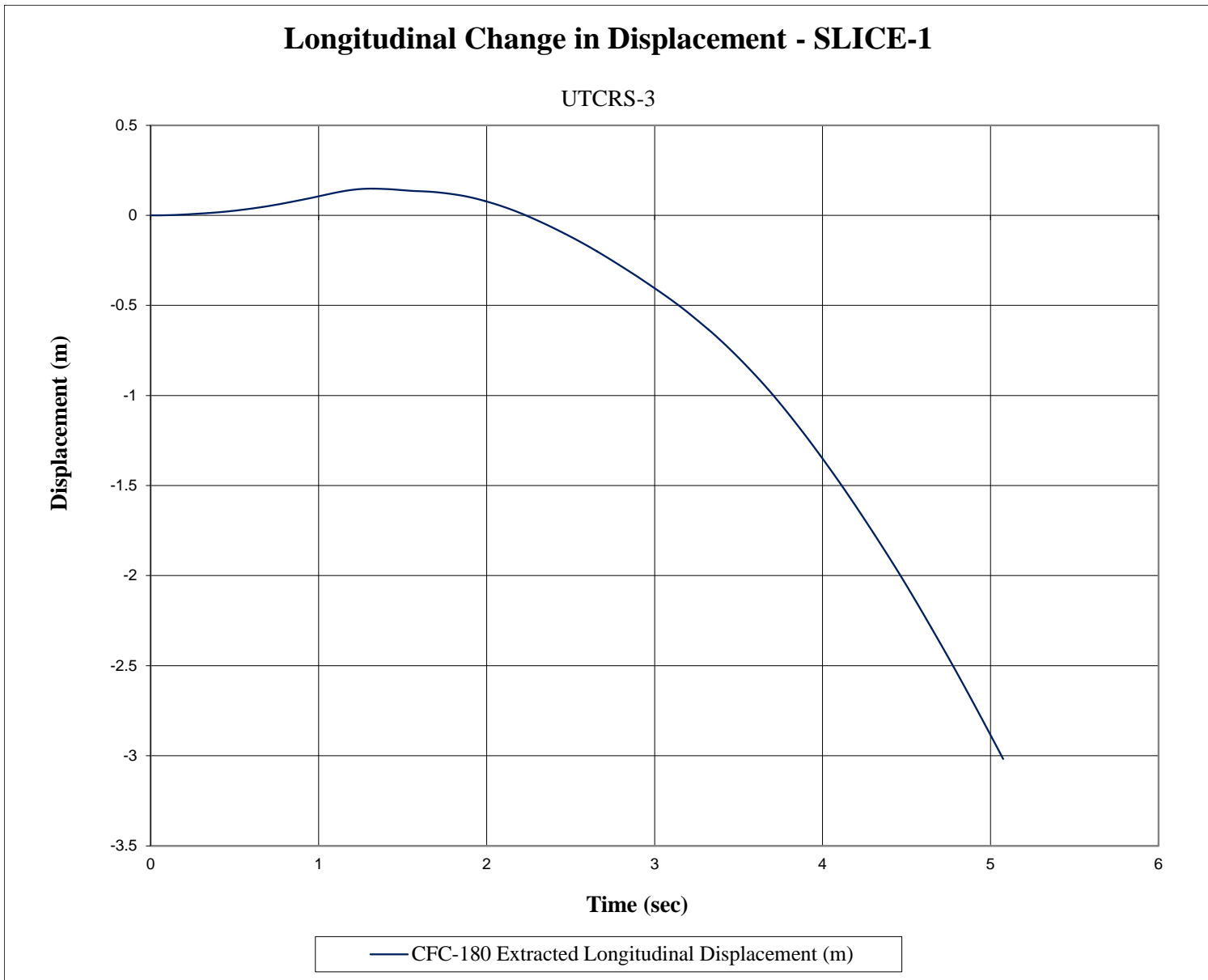

Figure C-21. Longitudinal Change in Displacement (SLICE-1), Test No. UTCRS-3

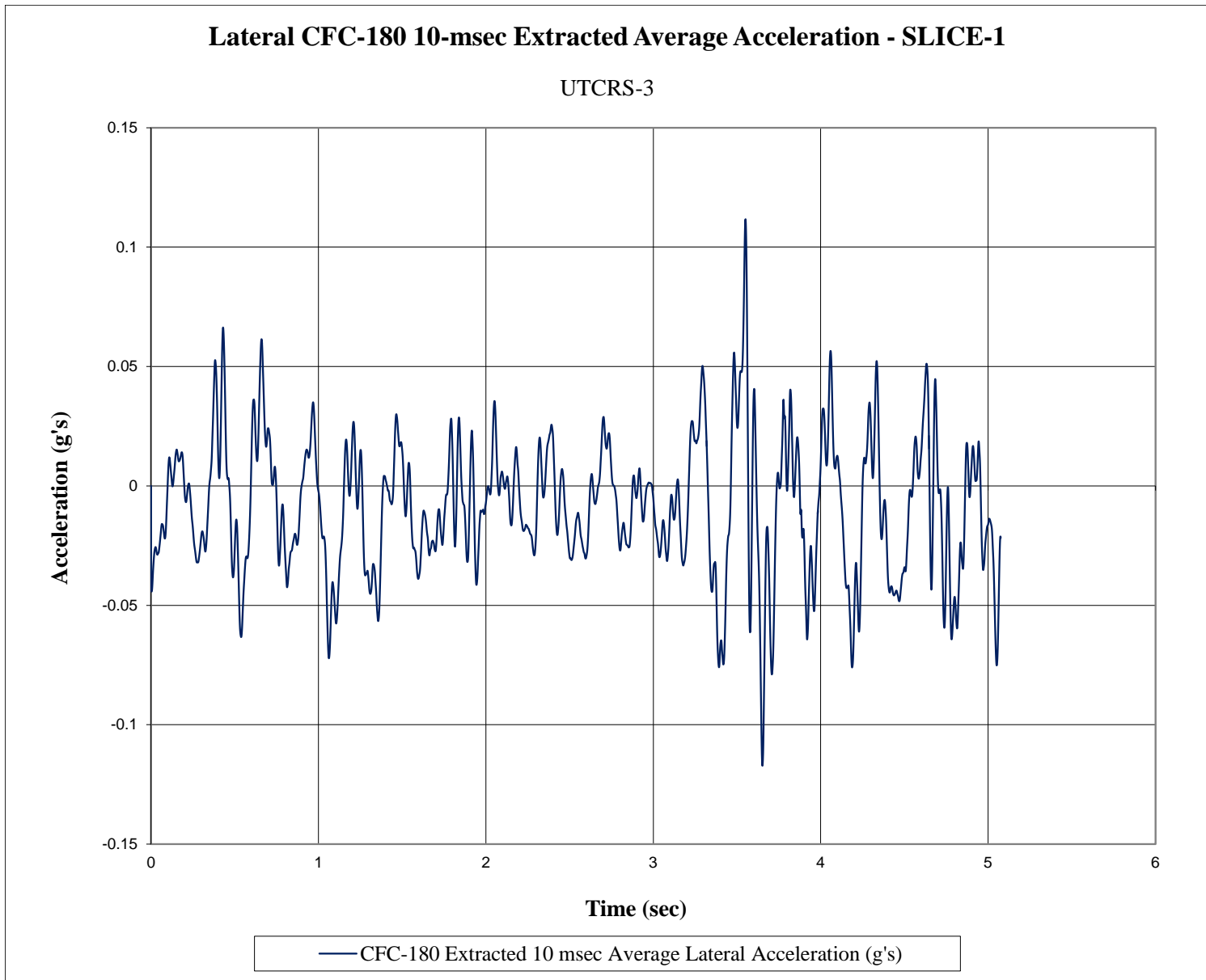

Figure C-22. 10-ms Average Lateral Acceleration (SLICE-1), Test No. UTCRS-3



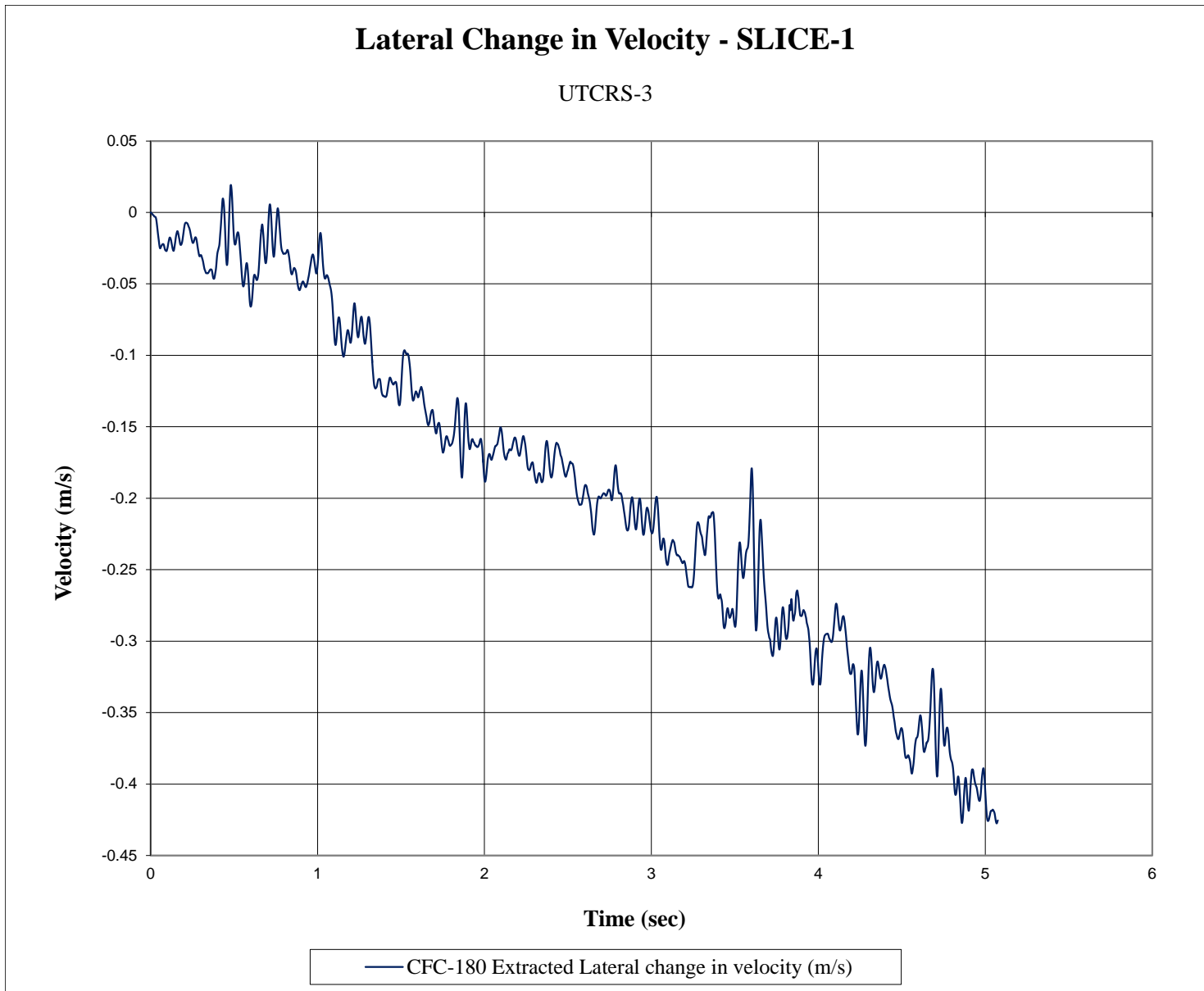

Figure C-23. Lateral Change in Velocity (SLICE-1), Test No. UTCRS-3

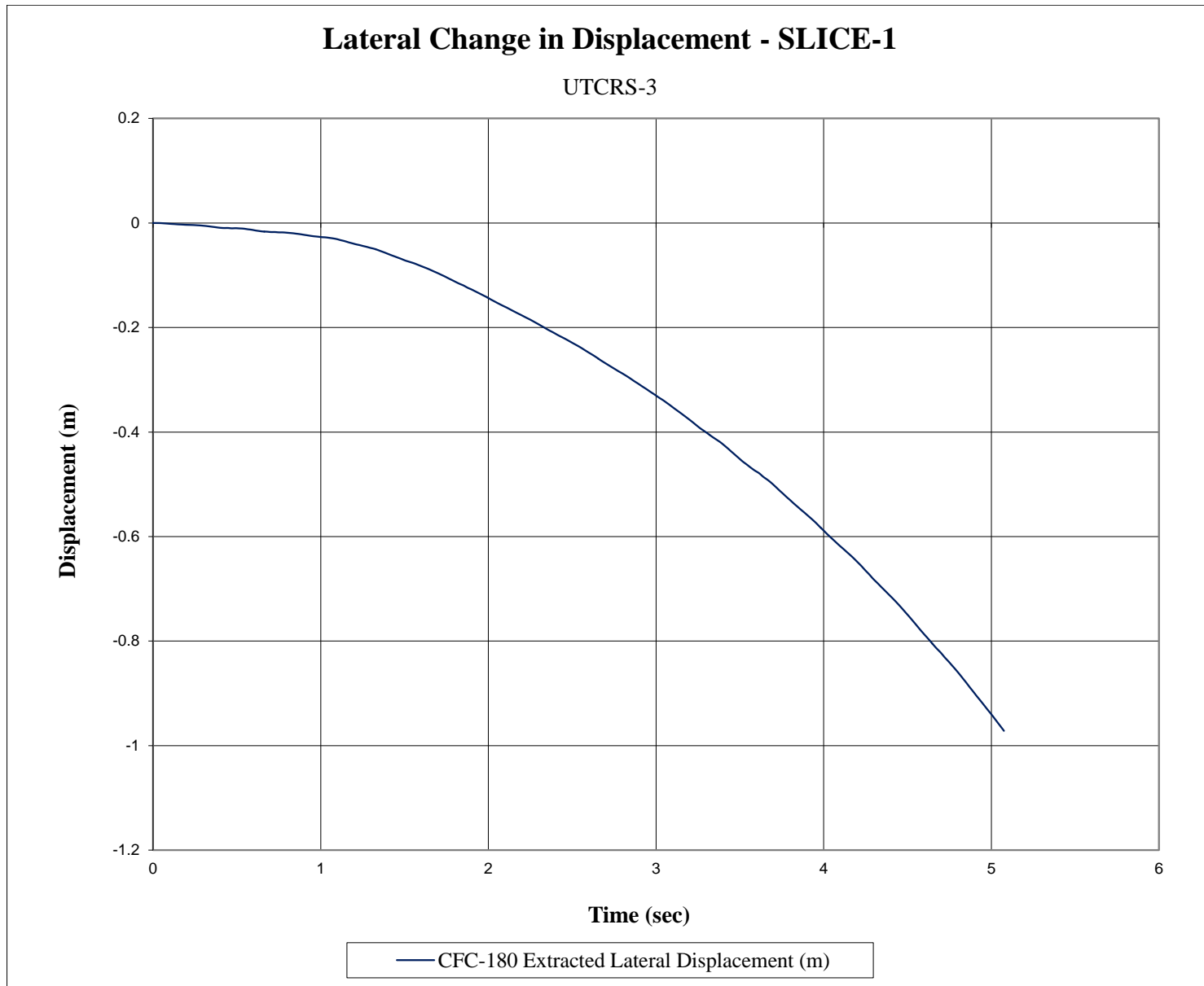

Figure C-24. Lateral Change in Displacement (SLICE-1), Test No. UTCRS-3

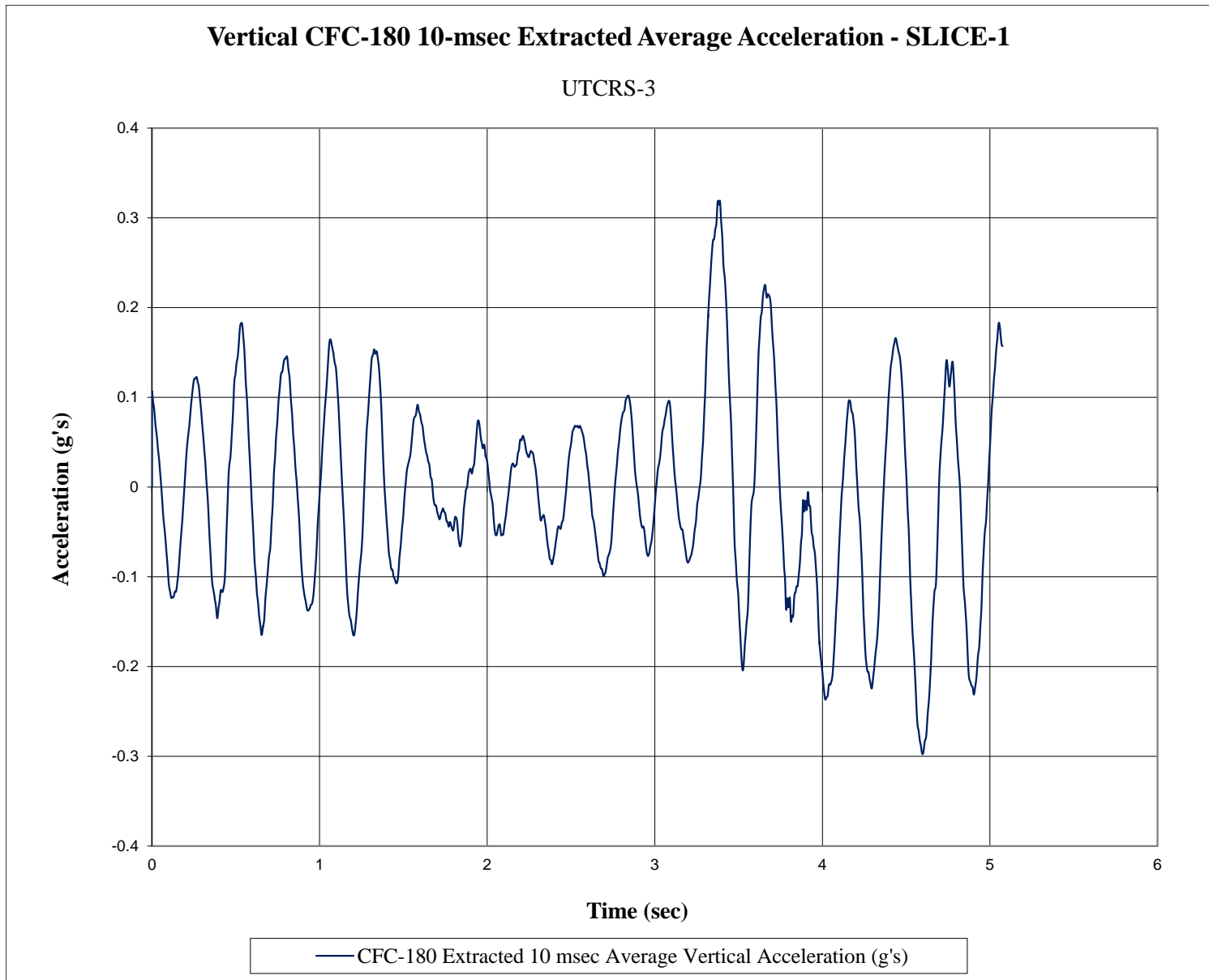

Figure C-25. 10-ms Average Vertical Acceleration (SLICE-1), Test No. UTCRS-3

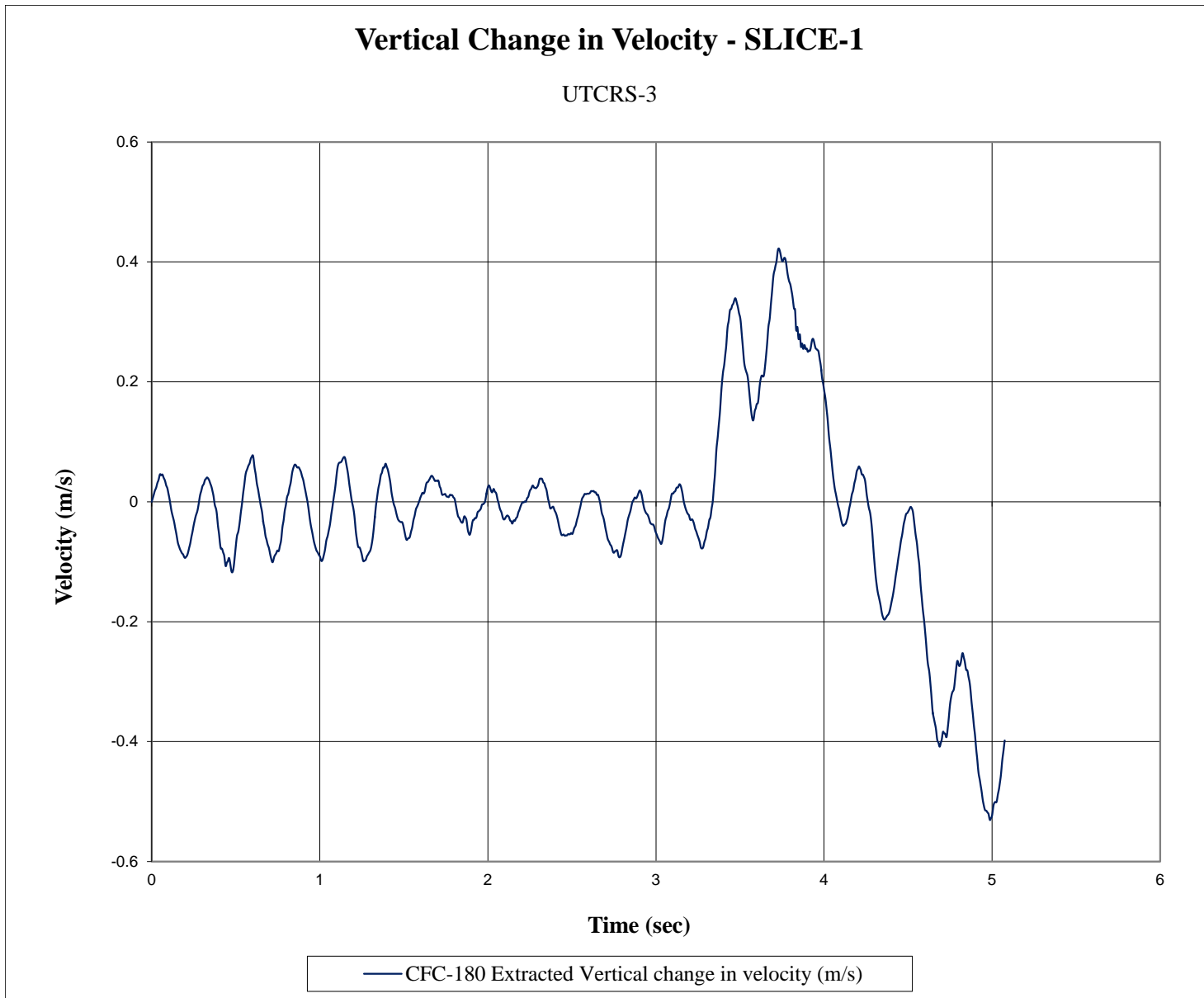

Figure C-26. Vertical Change in Velocity (SLICE-1), Test No. UTCRS-3

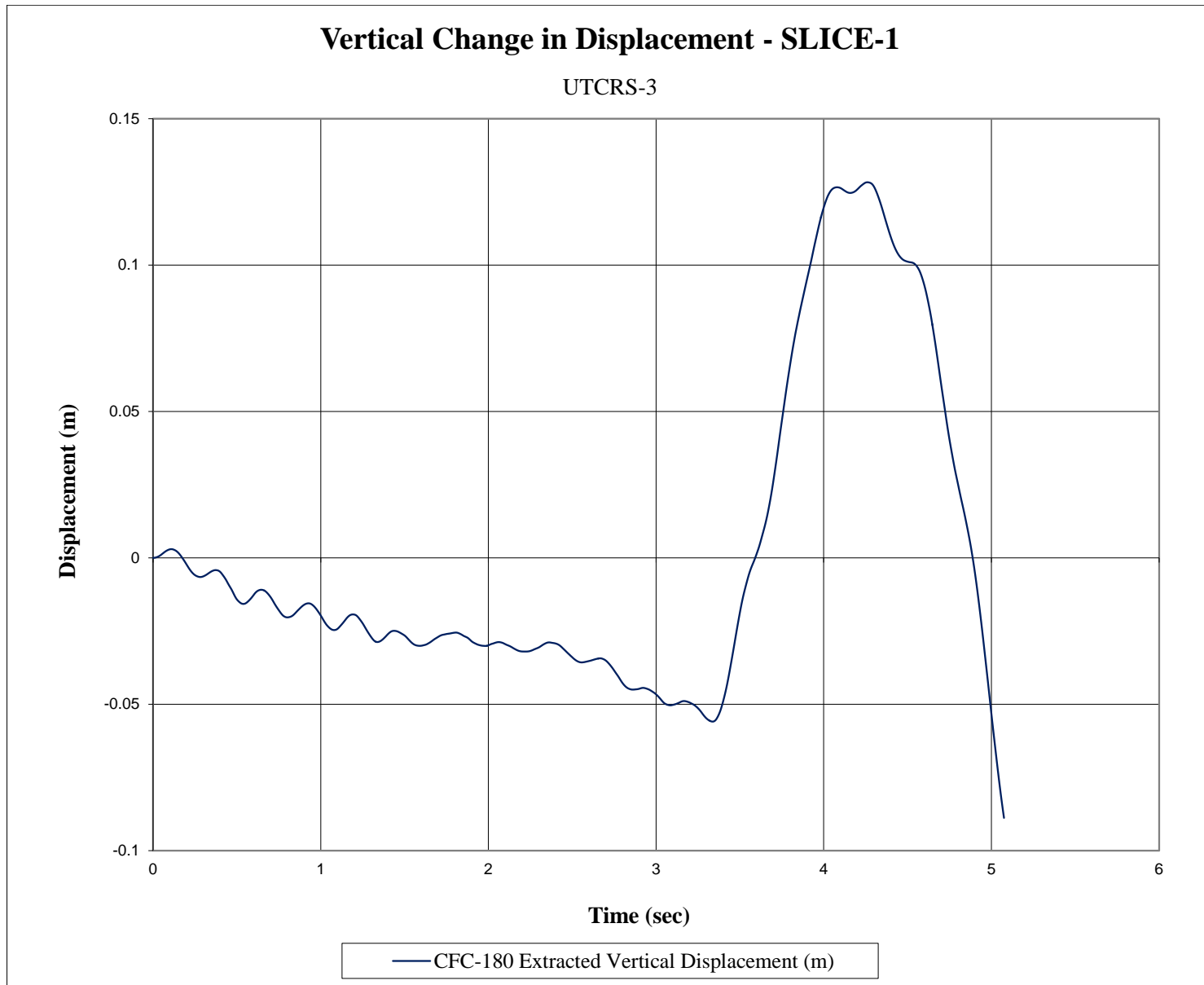

Figure C-27. Vertical Change in Displacement (SLICE-1), Test No. UTCRS-3

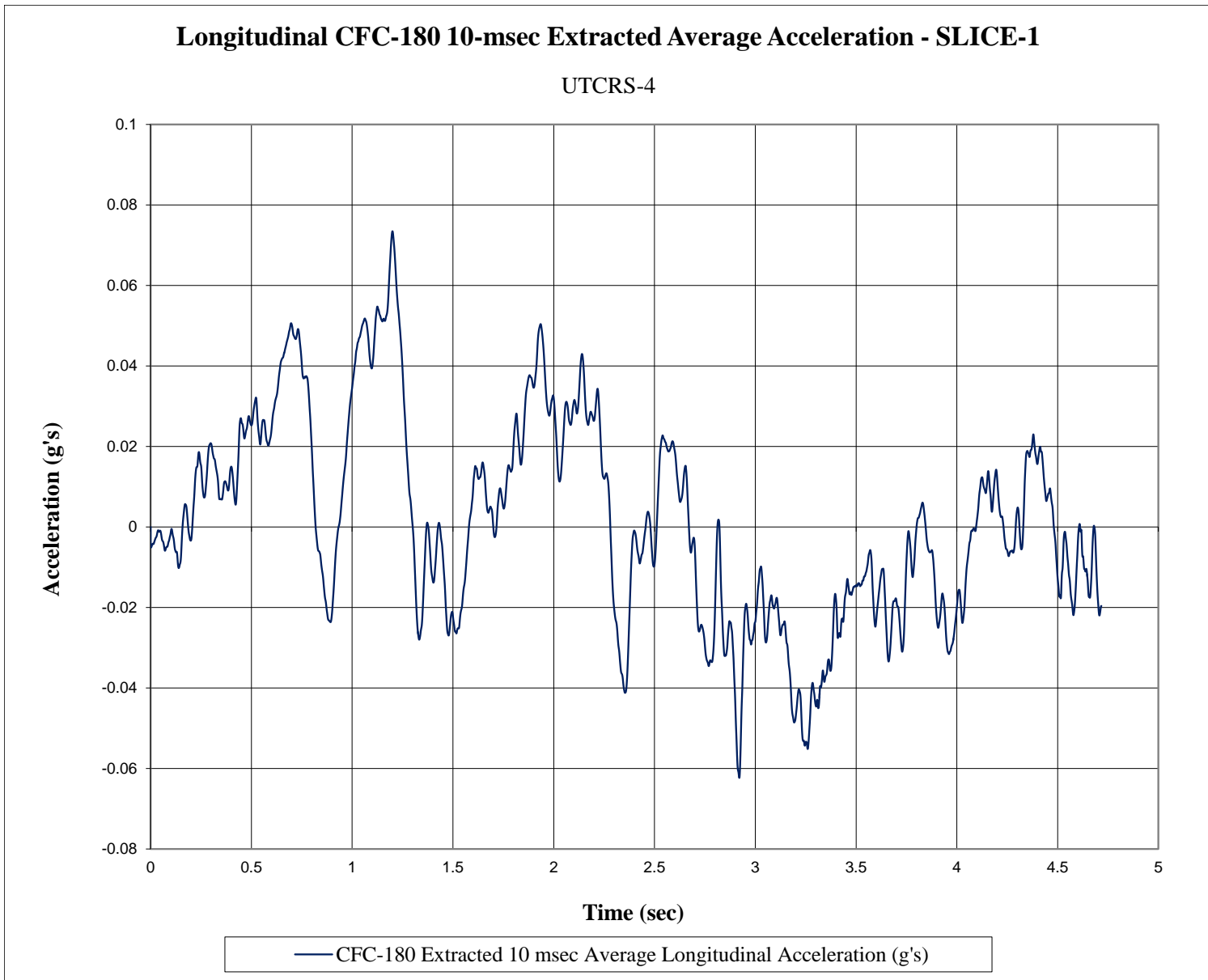

Figure C-28. 10-ms Average Longitudinal Acceleration (SLICE-1), Test No. UTCRS-4

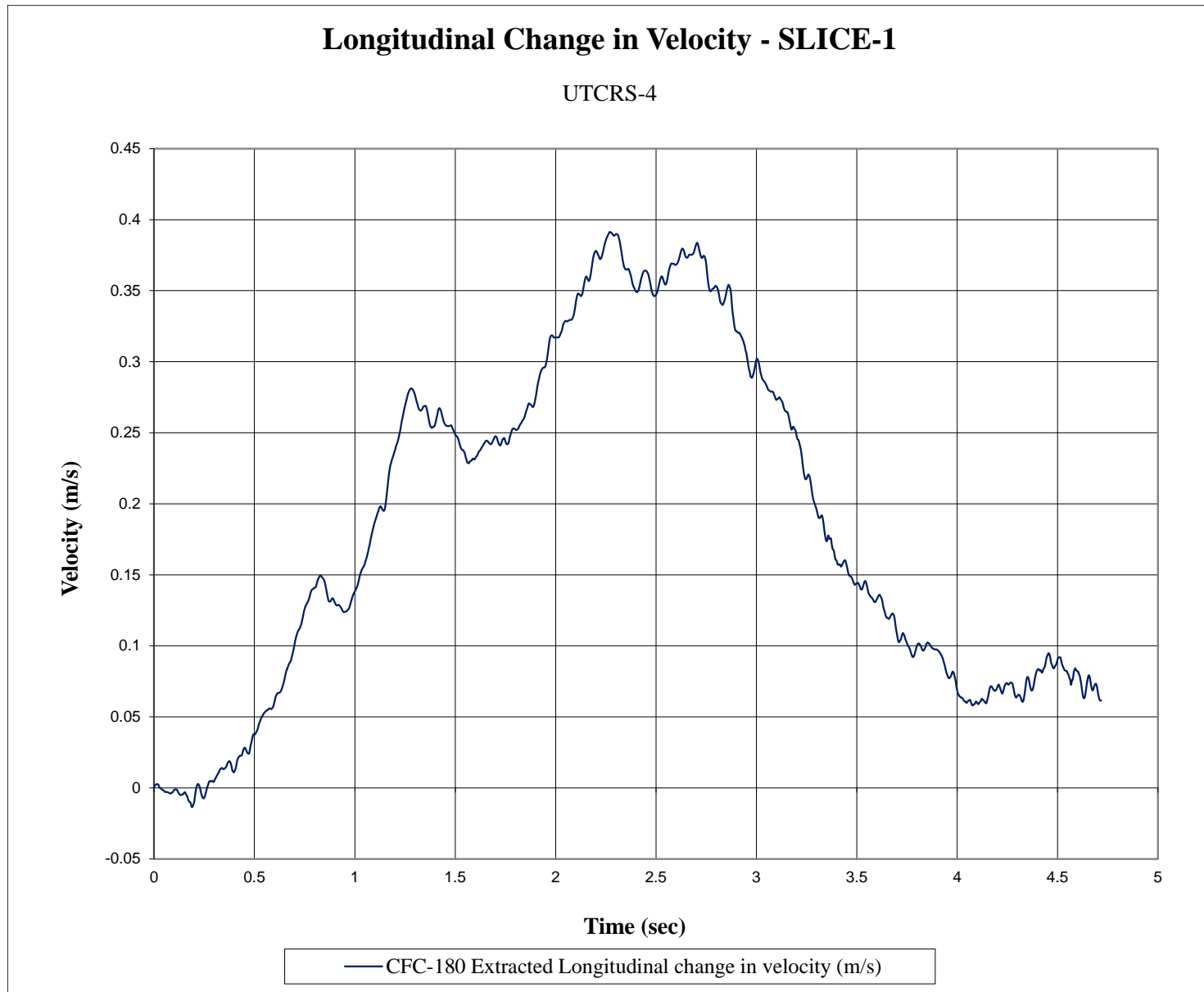

Figure C-29. Longitudinal Change in Velocity (SLICE-1), Test No. UTCRS-4



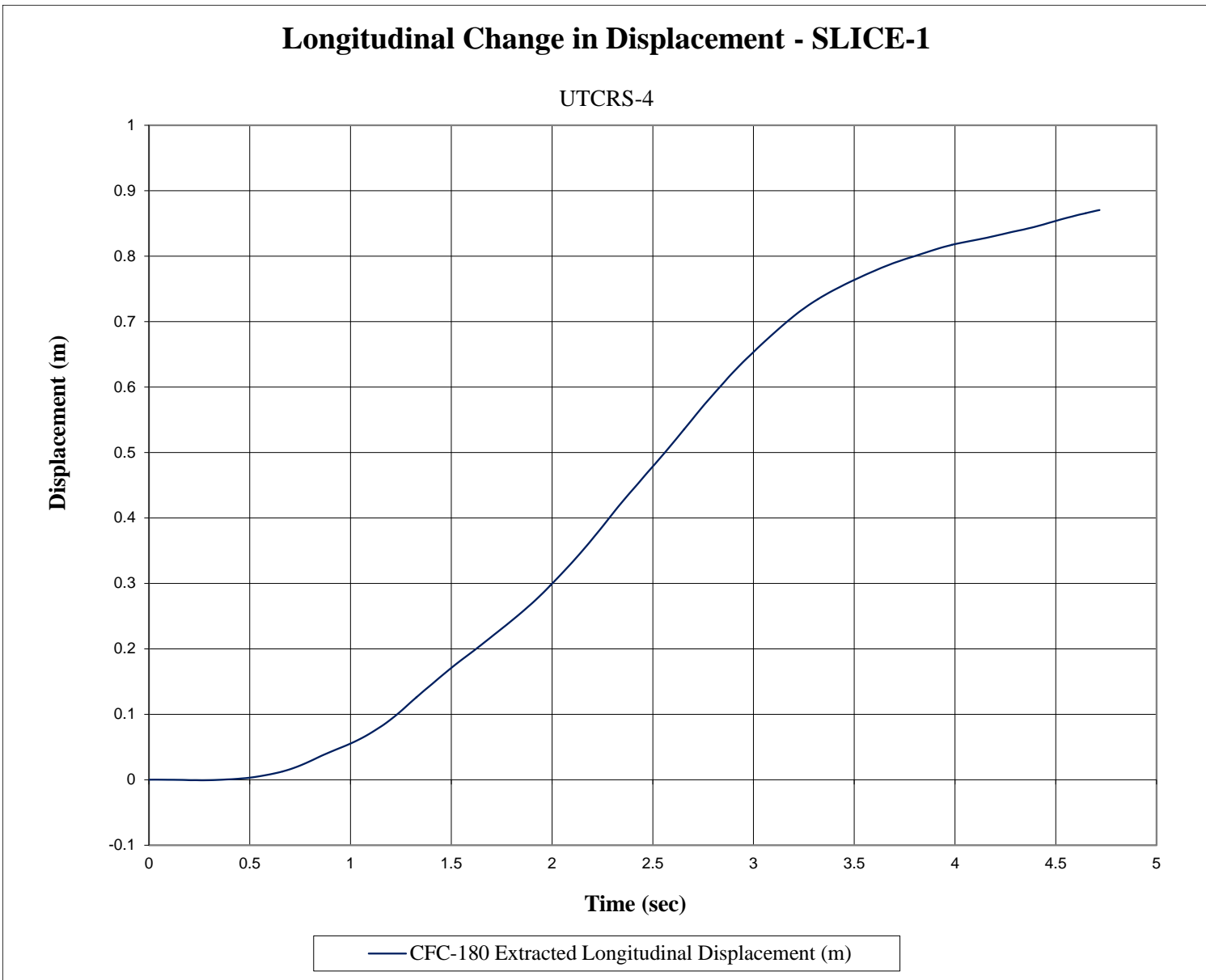

Figure C-30. Longitudinal Change in Displacement (SLICE-1), Test No. UTCRS-4

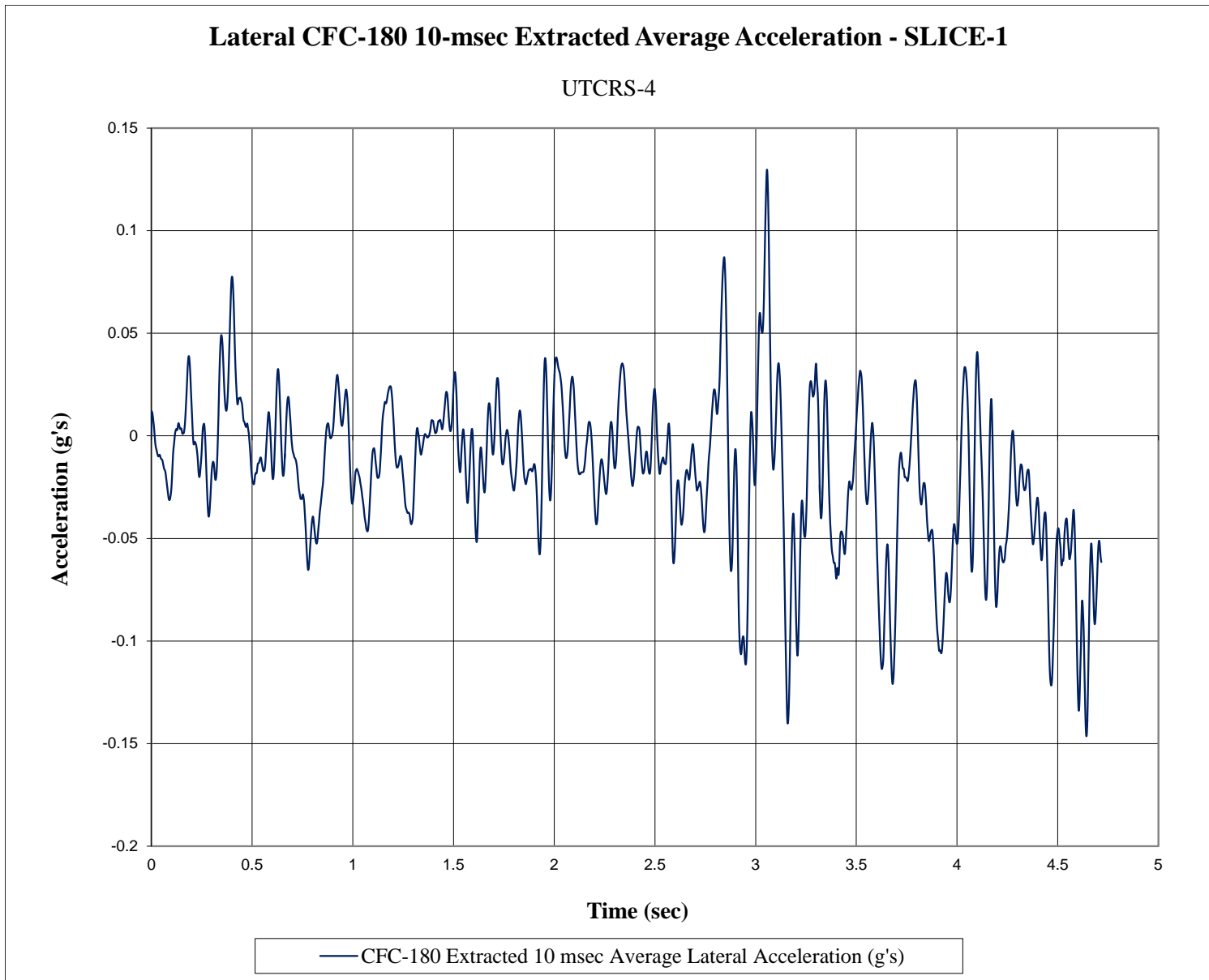

Figure C-31. 10-ms Average Lateral Acceleration (SLICE-1), Test No. UCRS-4

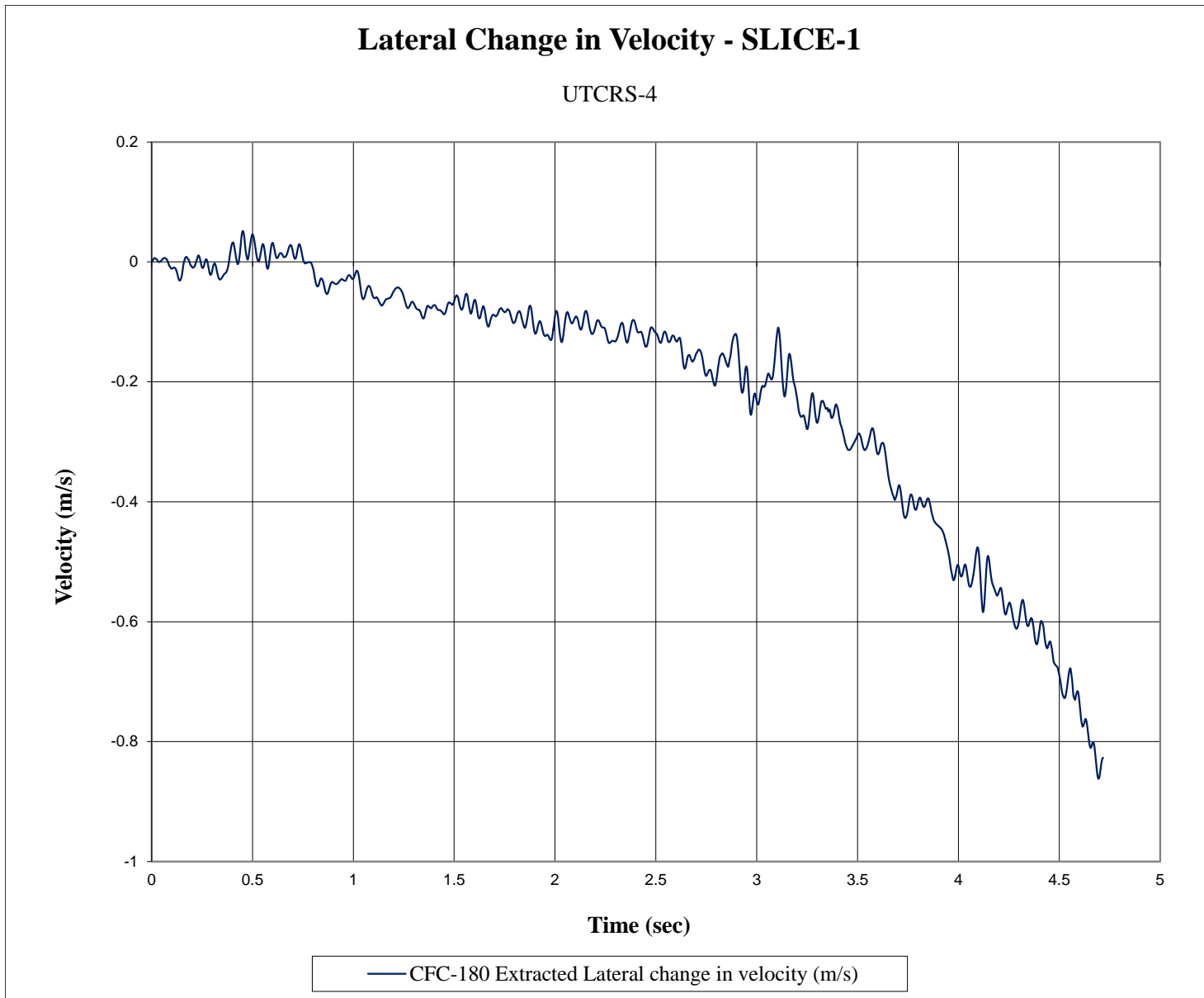

Figure C-32. Lateral Change in Velocity (SLICE-1), Test No. UTCRS-4

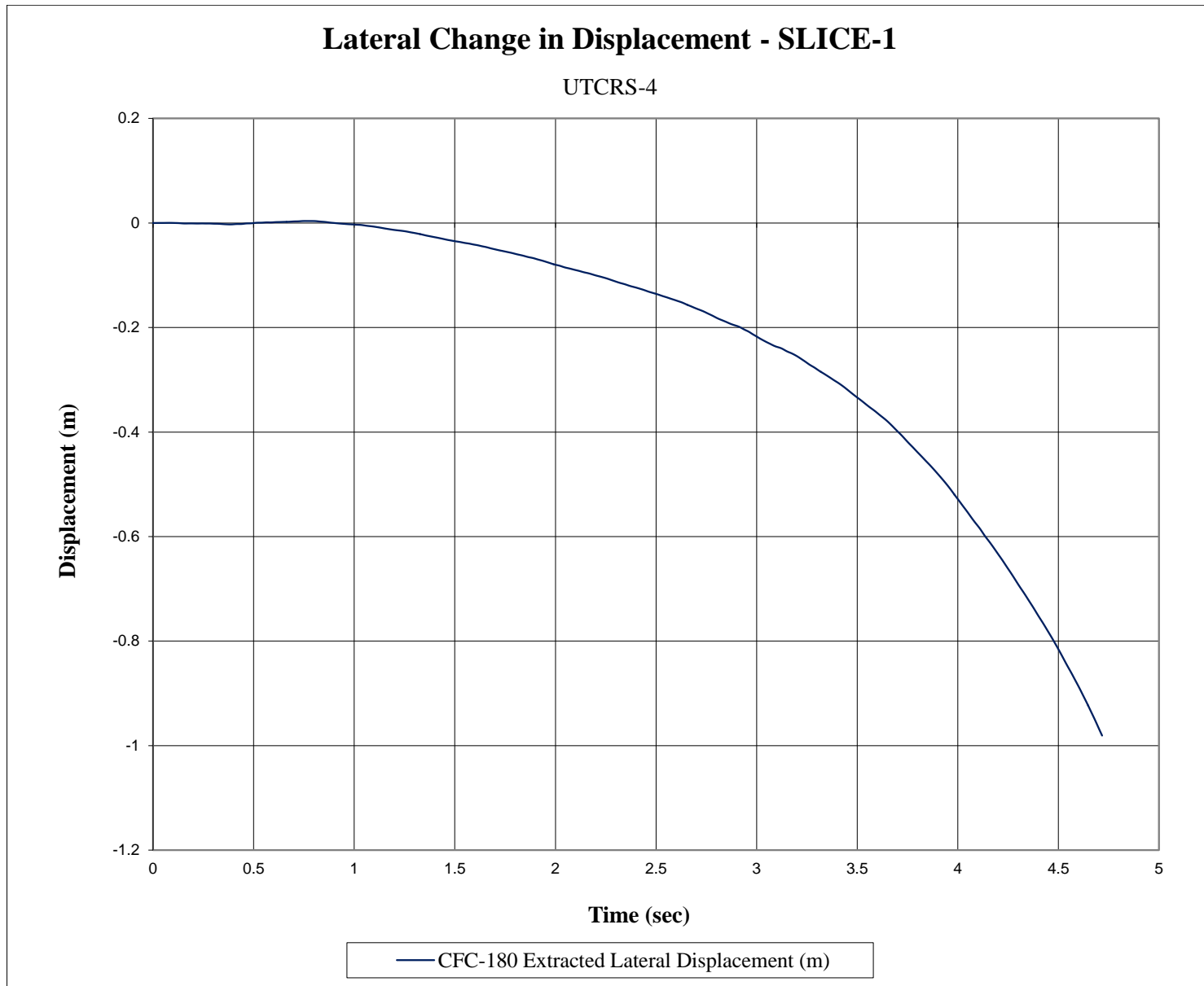

Figure C-33. Lateral Change in Displacement (SLICE-1), Test No. UTCRS-4

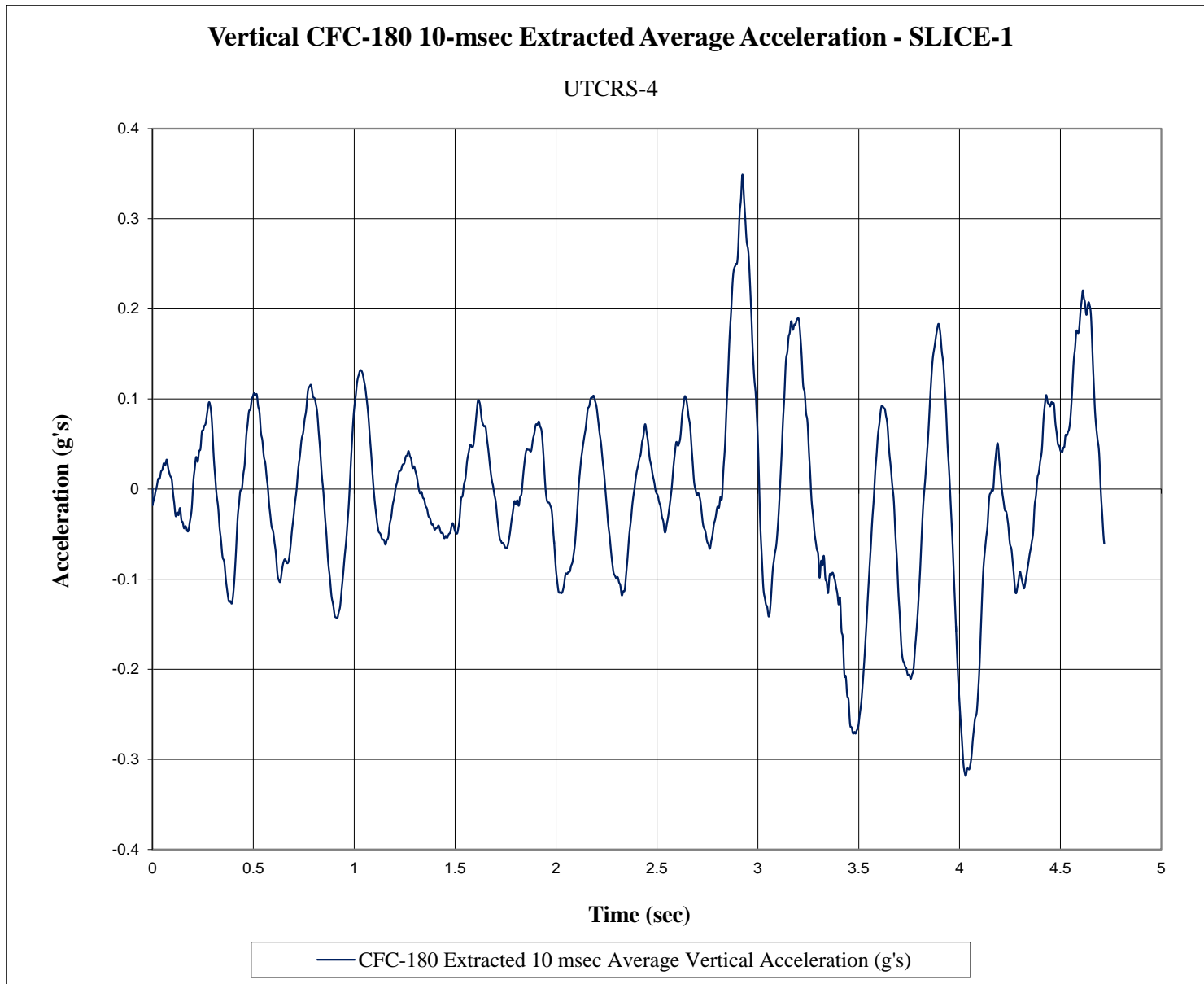

Figure C-34. 10-ms Average Vertical Acceleration (SLICE-1), Test No. UTCRS-4

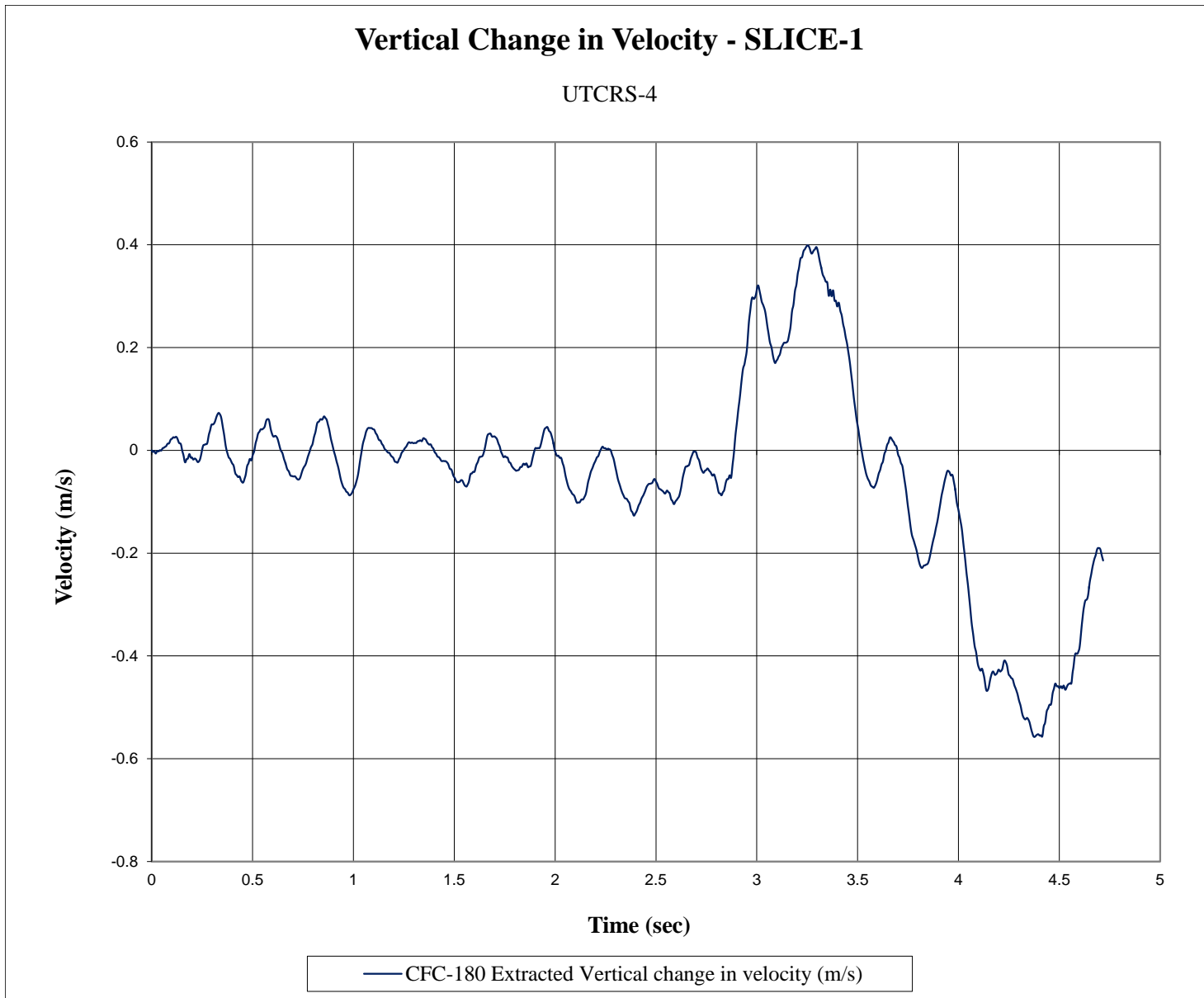

Figure C-35. Vertical Change in Velocity (SLICE-1), Test No. UTCRS-4

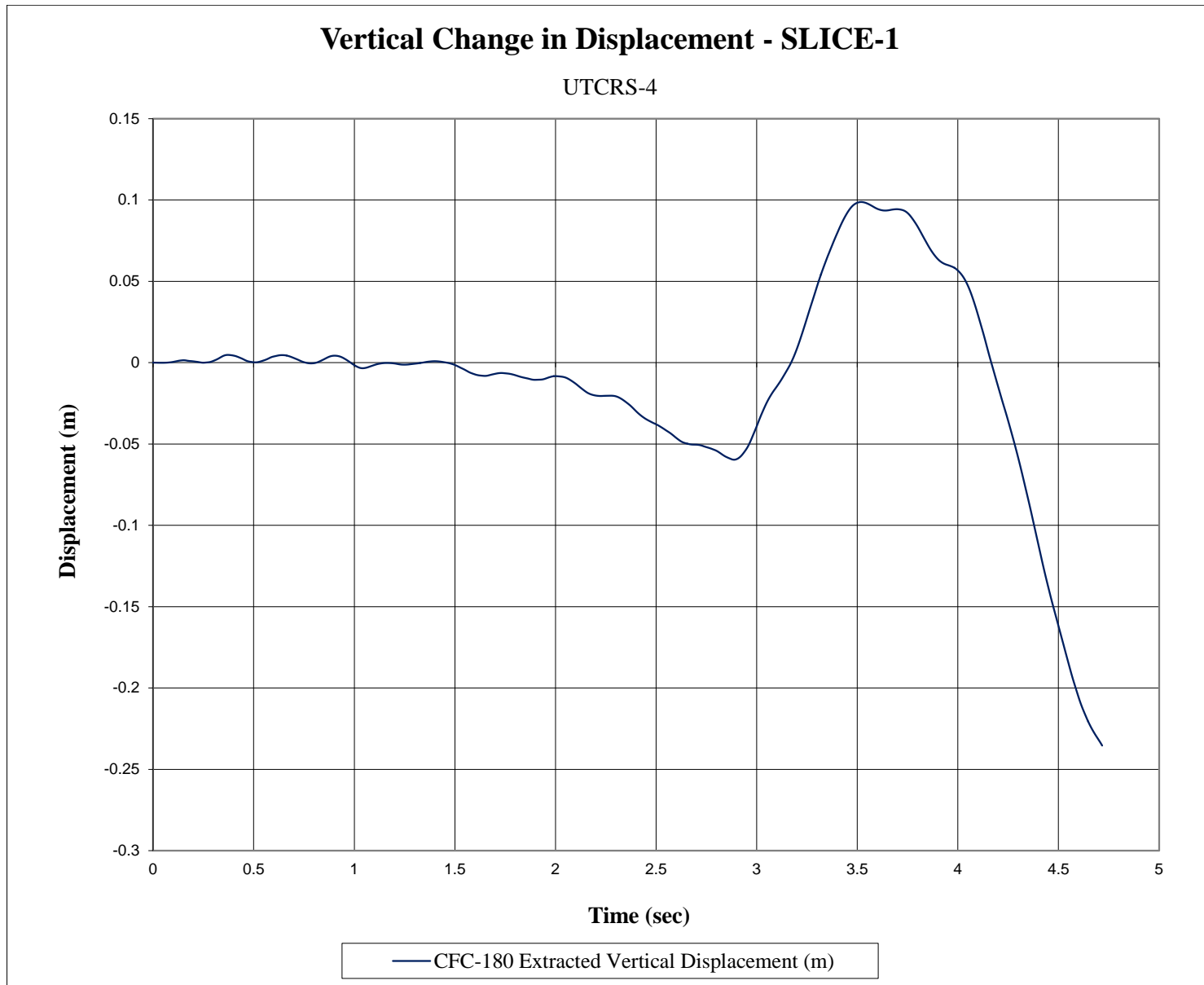

Figure C-36. Vertical Change in Displacement (SLICE-1), Test No. UTCRS-4



**END OF DOCUMENT**