

Experimental results of an innovative NIR- solar façade panels-based polygeneration system

Chiara Anfosso¹, Lorenzo Gini¹, Daria Bellotti^{1*}, Matteo Pascenti¹, Loredana Magistri¹

¹ Thermochemical Power Group (TPG), University of Genoa, Genoa, Italy

*Corresponding Author

ABSTRACT

This paper intends to present the experimental results of an integrated polygeneration system based on innovative thermal solar façade panels working with Near-InfraRed (NIR) radiation. The research goal is the evaluation of thermal energy performances of the integrated system based on innovative NIR façade panels and including different other devices for thermal and electrical energy production (i.e. prototype heat pump and CHP mGT). The innovative solution has been developed in the framework of 'ENVISION' H2020 European Project whose aim is the demonstration of a full renovation concept that harvests energy from all available building surfaces allowing visible aspects to be retained. In this paper, the 'ENVISION' Southern Demosite, located at the Savona University Campus (one of the venues of the University of Genoa), is presented together with the description of the solar panels' main characteristics, their site installation, and the thermal power calculation performed using experimental data.

Keywords: solar energy, NIR solar façade panels, polygeneration grid, energy system.

NOMENCLATURE

Abbreviations

NIR	Near Infrared Radiation
MPC	Model Predictive Control
DHN	District Heating Network
HP	Heat Pump
COP	Coefficient of Performances
CHP	Combined Heat and Power
TES	Thermal Energy Storage
mGT	Micro-Gas Turbine
SOC	State of Charge

1. INTRODUCTION

To achieve the European goal of an energy-neutral built environment in 2050 [1], the harvesting of solar energy from all building surfaces should be

improved. The efficiently managing of solar radiation on buildings provides enormous potential, since in EU28 a total of 60 billion square meters of façade surfaces exists, and the current usage of solar radiation on opaque surfaces is still minimal. Together with roofs, this would mean a total of 120 billion square meters of potential energy harvesting surfaces [2][3]. Considering that approximately 85% of existing dwellings were built before 1990 with poor insulation ($R \leq 1.6 \text{ m}^2\text{K/W}$), a major renovation will take place in the upcoming period. The developed solar façade panels work by absorbing the invisible part of the solar radiation, the Near-Infrared (NIR) one, constituting roughly 50% of the solar energy spectrum. In this way, it is possible to convert the maximum amount of solar energy and in the meanwhile keep the aesthetic and functional properties of the façade [4]. To investigate the NIR solar façade panels' performances and their potential contribution to an integrated polygeneration smart grid, a NIR faced panels demonstrator has been installed and tested at the Savona Campus of the University of Genoa responsible for the "Southern 'ENVISION' Demosite".

The integrated system is composed not only of the panels but also of a CHP, an innovative heat pump, and thermal energy storage. The whole integrated system is also connected to the Savona Campus smart polygeneration grid and district heating network to satisfy part of the electric and thermal demand. The test rig is described in detail in the following.

2. FACILITY

The system here investigated integrates the 'ENVISION' harvesting panels with a 100kWe CHP-mGT, an innovative high-efficiency prototype heat pump, and two thermal energy storages with the aim of testing the performance of the 'ENVISION' harvesting solutions and their integration with other devices in a smart polygeneration microgrid which was already present at the Savona Campus.

The integrated system has a double ring configuration which allows the connection to both the hot and cold side of the Campus existing DHN in order to test its operation also in a real environment. The system has

been also equipped with an advanced Model Predictive Control (MPC), whose application in the field of the smart grid has risen consistently in the last decade [5][6]. The MPC

following, the main components of the plant are described in detail.

3. SOLAR FAÇADE PANELS

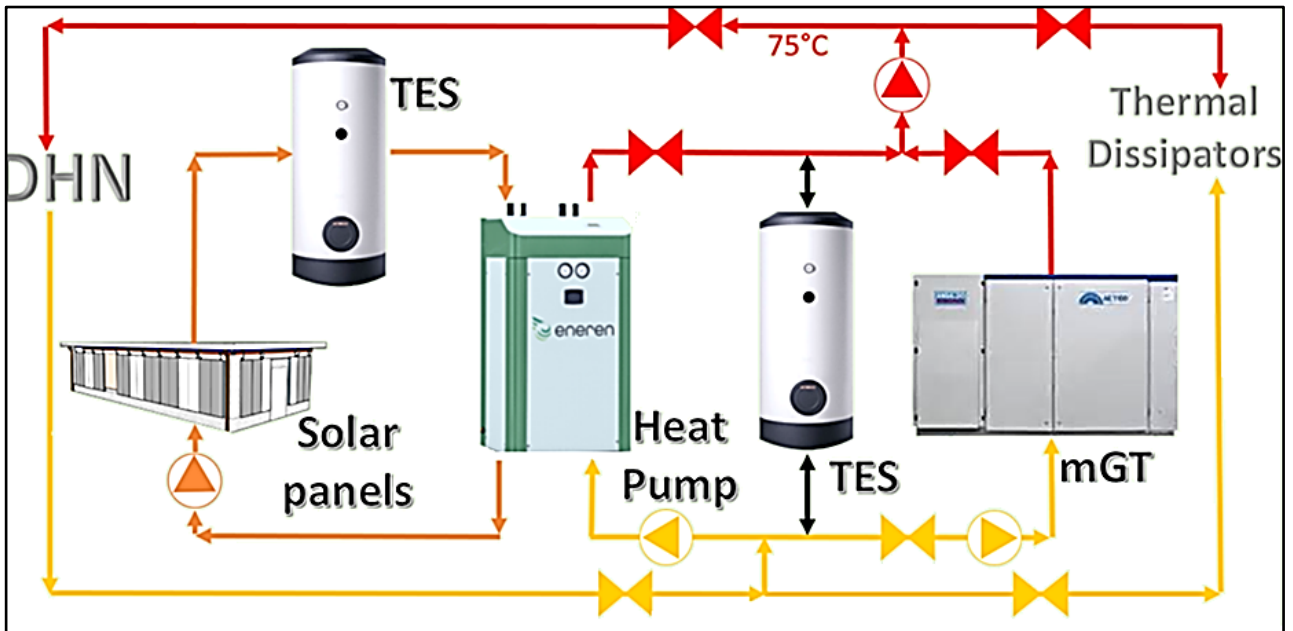

Fig. 1 Savona University Campus Integrated System Plant Layout

allows for properly controlling all the system components and their interaction by defining the best control and management strategy of each component to satisfy the thermal and electrical demands and optimize renewable energy exploitation. The aforementioned DHN is a third-generation one requiring a temperature of about 75/80°C whereas the return water temperature is about 50°C. The maximum expected temperature coming from the panels is about 45°C. Therefore, the integrated system configuration requires the solar façade panels to be connected to the heat pump that works as a temperature booster in order to guarantee the temperature required by the DHN. A low-temperature thermal energy storage is installed between the faced panel circuits and the HP to mitigate temperature fluctuations due to the solar availabilities on the heat pump. The CHP unit (100 kWe/160kWth micro-Gas Turbine) is also integrated into the system providing both electric and thermal energy. An high-temperature thermal energy storage is installed in order to guarantee one more degree of freedom in the management of both thermal and electric demand. Moreover, thermal dissipators are present to allow tests to be conducted independently of the DHN requirement and also to simulate different thermal demand profiles. Fig. 1 reports a simplified layout of the “Southern Demosite” test-rig. In the

The installed solar faced panels are innovative solar collectors that have been developed by TNO (*Nederlandse Organisatie voor Toegepast-Natuurwetenschappelijk Onderzoek*) and differ from the commercial ones exclusively for the particular surface coatings, realized with the purpose of enhancing the absorption capacity of the collectors in the field of Near-Infrared Radiation (NIR), seeking a compromise between aesthetic appeal and absorption. Compared to traditional solar panels, ‘ENVISION’ panels can be integrated along the entire façade of the building, greatly increasing the exchange surface. In addition, the shape of the panel can be customized ensuring the maintenance of the aesthetic appearance of the façade and the possibility of adapting to any need. The panels’ coating has been realized in different colors (e.g. white, black, red, grey), and, depending on the painting, the panels’ performance is different based on the ability to absorb solar radiation. With respect to traditional collectors, heat production occurs at lower temperatures that, on the one hand, prevents the risk of damage to parts of the system susceptible to high temperatures (>90°C), e.g. sheaths, on the other hand, in order to reduce the heating consumption of the building, it has been necessary to couple the collectors to an innovative heat pump for heat production. From a technical point of view, the

same considerations applicable to conventional solar collector systems are valid. In fact, the installation requires a heat storage tank, circulation pumps, valves, temperature sensors, a heat exchanger, mass flow meters, etc. [7]. The panels can be connected either in series or in parallel, depending on the temperature and the flow rate required, without any constraints imposed by the geometric configuration of the façade. In the test rig here describe a total of 34 panels have been installed of which 24 grey and 10 white. Couples of panels of the same colors have been connected in series resulting in 17 panels' couples.

In Fig. 2 a schematic representation of the installed panels' configuration is reported. Then, each couple has been connected in parallel to be able to individually evaluate the performance depending on the color, the position, and the variation of solar radiation. In fact, since the surface color is the parameter that mostly affects the panels' performances, it is fundamental to evaluate and compare the thermal energy produced by both panels subjected to the same solar radiation profile.

All the panels' couples are connected to two manifolds: the inlet manifold at low temperature and the outlet manifold at higher temperature. The manifolds connect the panels' circuit with the TES.

The working fluid of the panels is a 30% water-glycol solution, and the total mass flow rate is about 42.5 l/min that is equally distributed among the panels' couple thanks to proper valves installed at the inlet of the panels.

In order to evaluate the panels' performances, each couple has been equipped with temperature probes at the inlet and the outlet. The recirculation of the working fluid is guaranteed by a pump of about 0.55 kW.

The technical configuration and operative data are summarized in TAB.1.

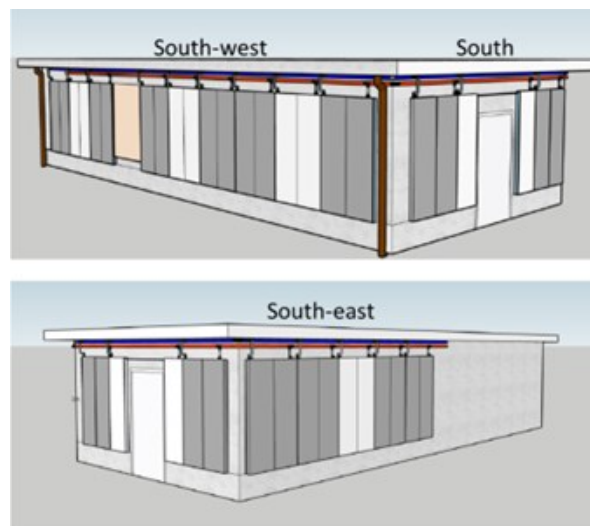

Fig. 2 'ENVISION' Solar Façade Panels Installation Configuration

TAB.1. – Solar façade panels technical data

SOLAR PANELS NUMBER		
Grey	Nr.	24
White	Nr.	10
SOLAR PANELS		
Material	Copper	
Fluid Type	Water + 30% Glycol	
Mass Flow Rate for Panels Couple	2.5	l/min
Operating Pressure	1-2	Bar
Total Flow Rate	42.5	l/min

3.1. Heat Pump

The HP is a fundamental component able to provide to the district heating network the required temperature of about 75°C-80°C. The source at low temperature is represented by the solar façade panels whereas the high-temperature source is the hot water coming from the DHN at about 50°C. The thermal energy produced by the HP can be both used to supply the Campus thermal demand or can be stored in order to be used at a later time when required (e.g. to cover the thermal peak demand or during the night).

The heat pump installed here is a prototype one since a market available HP has been modified and equipped with a particular tesla turbine in order to recover the expansion energy of the working fluid and improve the global efficiency of the HP.

Tab. 2 HP Technical Data

EKW050K DATA			Heating@50/75°C;30/25°C;100%;		
Maximum absorbed current (FLA) [without options]	A	21	Heating capacity	kW	36,5
Start-up current (LRA) [without options]	A	118	Water Flow user side	l/h	1280
Sound power level Lw (base unit)	db(A)	74	Water Pressure drops user side	kPa	<5
Sound pressure level Lp (base unit)	db(A)	43	Water Flow source side	l/h	4661
Sound power level Lw (Low noise unit)	db(A)	70	Water Pressure drops source side	kPa	9
Refrigerant		R134a	Total Power input	kW	10,1
GWP		1430	Total Absorbed Current	A	16,2
Oil Type		POE RL32-3MAF	COP		3,62
Oil Volume	l	3,4			
Dimensions [LxDxH]	mm	804x607x1462			
Weight without options	kg	296			
Heating@50/75°C;20/15°C;100%;			Heating@50/75°C;40/35°C;100%;		
Heating capacity	kW	27,3	Heating capacity	kW	46,3
Water Flow user side	l/h	957	Water Flow user side	l/h	1622
Water Pressure drops user side	kPa	<5	Water Pressure drops user side	kPa	<5
Water Flow source side	l/h	3067	Water Flow source side	l/h	6391
Water Pressure drops source side	kPa	<5	Water Pressure drops source side	kPa	16
Total Power input	kW	10,0	Total Power input	kW	10,0
Total Absorbed Current	A	16,1	Total Absorbed Current	A	16,0
COP		2,73	COP		4,65

The tesla turbine has been installed in parallel with the traditional isenthalpic valve to allow to operate in two possible configurations [8][9][10]. The use of a Tesla Turbine in place of the traditional isenthalpic valve has a double benefit: (i) the increase in enthalpy difference reducing the temperature at the inlet of the evaporator that, as consequence will increase the COP of the HP; (ii) the exploitation of the enthalpy head producing electrical energy. TAB.2 summarizes the technical specification of the installed HP.



Fig. 3 Innovative HP installed at the Savona Campus

3.2. CHP – Micro gas turbine

The micro-gas turbine is a key component able to provide both thermal and electrical power to satisfy the users' demand for the Smart Polygeneration Microgrid [11][12]. The CHP unit is fueled by methane. The thermal power produced is in the form of hot water at 75/80°C. mGT is used both to supply thermal energy directly to the DHN and also to charge the TES in order to use the stored energy to cover the night thermal energy demand avoiding a further startup of the machine. The mGT is used, as well as to cover the electrical demand of the campus, also to cover the electrical demand of the HP and all the auxiliaries.



Fig. 4 CHP unit installed at the Campus - external side

Tab. 3 mGT Technical Data

General	ANSALDO AE T100		Performances	
Installation	Indoor / Outdoor		Electrical output	(100 ± 3) kWel
Size (WxHxL)	(900 x 1900 / 3300 x 3900) mm (CHP)		Thermal output	160 kWth
Weight	2770 / 3100 kg (CHP)		Electrical efficiency	(30 ± 2) %
Fuel	Natural Gas (methane)		Efficiency CHP	(75±2) %
Microturbine			Exhaust gas flow	0.79 kg/s
Compressor type		Centrifugal, single stage	Exhaust gas temperature	270°C
Turbine type		Radial, single stage	Average sound pressure	72 dB(A) @ 1 m
Type/Number of combustion chambers		1 chamber, CAN type	Fuel requirements	
Pressure in combustion chamber		4.5 bar(a)	Required pressure	(0.02 - 0.1) bar(g)
Turbine Inlet Temperature (TIT)		950°C	Required temperature	(0 - 60) °C
Number of shafts		1 (single shaft)	Lower Heating Value (LHV)	(38 - 56) MJ/kg ≈ (27 - 40) MJ/Nm ³
Rated rotational speed		70,000 RPM	Wobbe Index	(43 - 55) MJ/Nm ³
Electrical data			Consumption*	333 kW = 34 Nm ³ /h
Frequency output		50 Hz (60 Hz on request)	Emissions*	
Voltage output		400 V(AC), three phases	NOx ≤ 15 ppm(v)	31 mg/Nm ³
			CO ≤ 15 ppm(v)	19 mg/Nm ³

(*): @ full load - (100 ± 3) kW - 15% O₂

The efficiency is about 30% (electrical) and 75% (CHP). The NO_x and CO emissions remain lower than the limit of 15 ppmv. As 'ENVISION' refers to a residential environment also the noise level has been taken into consideration knowing that the maximum admissible sound power level is 90 dBA. Some mGT technical characteristics are reported in Tab. 3.

3.3. Thermal Energy Storage

The working principle of the TES that are installed at Savona Campus is to maintain constant the water liquid volume while varying the water temperature which consequently allows a variation in terms of stored energy. Two TES are installed in the Demo: the low-temperature TES and the high-temperature TES. The former is directly connected to the solar façade panels circuit and the HP; it stores the energy provided by the panels and works as a temperature buffer limiting the temperature fluctuation at the HP evaporator side. The latter stores the exceeding thermal energy produced by the integrated system in order to release it whenever required. It, therefore, allows to balance the energy demand and reduce the peak demands.



Fig. 5 Thermal Energy Storage

3.4. Thermal dissipators

Four thermal dissipators have been installed in order to manage the produced thermal power and to simulate a thermal user demand when the system is not connected to the DHN. The thermal dissipators are composed of shell and tube heat exchangers and variable speed fans, controlled by an inverter.

3.5. Acquisition system

TES state of charge 4 PT100 probes have been installed

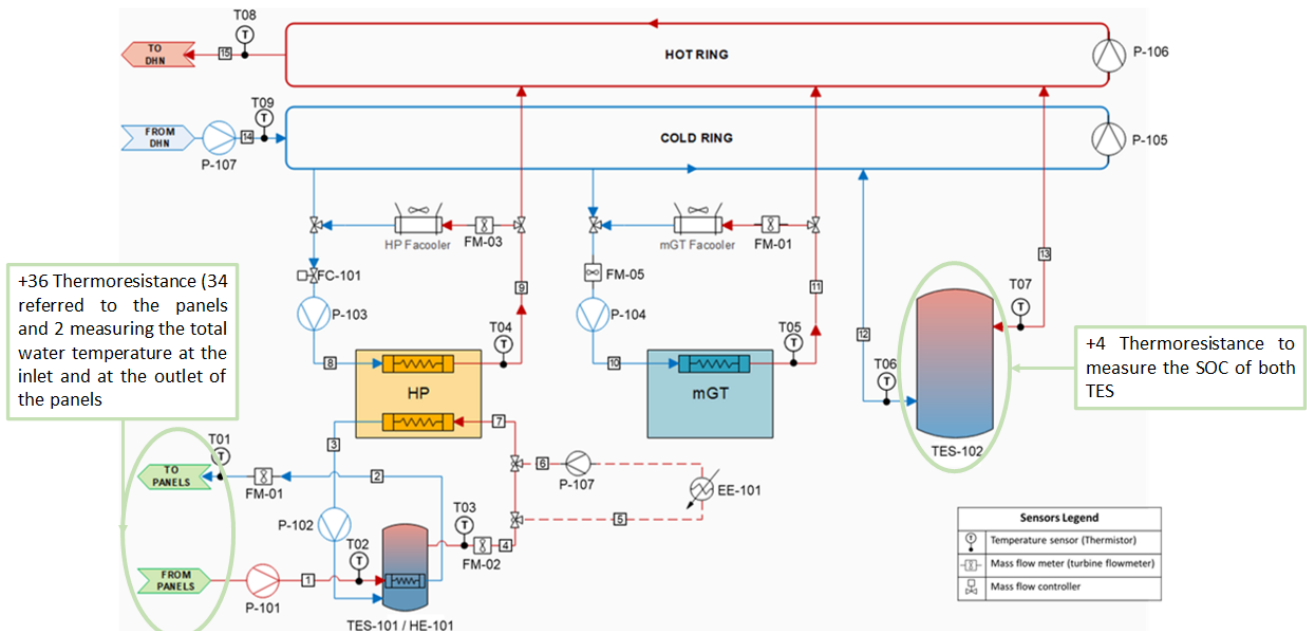

Fig. 4 Integrated system P&ID

In order to monitor and evaluate the system performance during the test campaign, several sensors and flow meters have been installed and a dedicated acquisition system has been developed.

The list of sensors used in the plant is reported in Tab. 4 whereas in Fig. 6 the P&ID of the integrated test rig is shown.

Tab. 4 List of Sensors

Name	Manufacturer and model	Accuracy
Temperature transmitter	TC Direct PT100	±0.15 °C at 0°C
Pyranometer	Soluzione Solare PYR1-420	±0.2%
Mass flow transmitter	FLS F3.00.H	±0.5 %

To monitor the panels' performance, each panel's couple has been equipped with PT100 temperature probes to measure the inlet and the outlet water temperature and a mass flow meter to monitor the water flow rate and verify that it is equally distributed among each panel. Solar radiation sensors have been also installed on the South and South-East sides to be able to correlate the thermal power produced by the panels with

the incoming solar radiation. Even more, several other temperature probes have been located in different positions of the integrated system together with mass flow meters and mass flow controllers. To measure the

along with both thermal energy storage tanks, from the bottom to the top.

Thanks to all the installed sensors, all the measured parameters according to the P&Id are as follow:

- Thermal and electrical energy required by smart grid
- Heat Pump electrical requirement
- mGT fuel consumption
- mGT heat and power production
- Inlet and outlet water temperature of panel circuit (2 probes)
- Inlet and outlet water temperature for each panels couple (34 probes)
- Storage temperature (4 probes for each TES)
- Solar irradiance (3 sensors)
- Mass flow rate on each branch (17 mass flow meters for panels circuit + 8 mass flow meters for the plant branch)
- HP operating pressures
- TES state of charge
- Plant temperatures (27 probes)

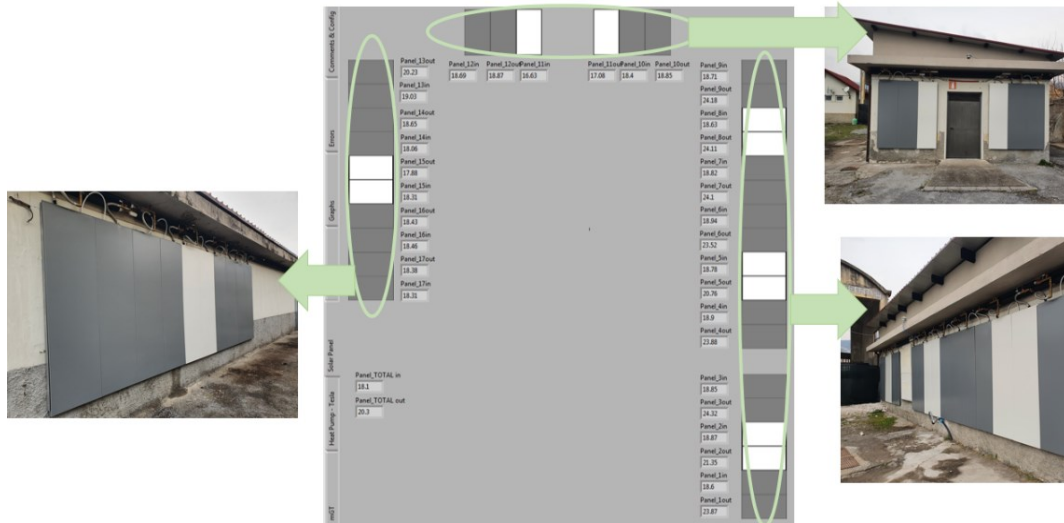

Fig. 7 Panel Circuit's Temperatures Acquisition System

All the data coming from the test-rig are acquired by LabVIEW (the integrated development environment for the National Instruments visual programming language). Thanks to the LabVIEW interface, it is possible to acquire all the measured data and control all the main system components as well as the auxiliary machines such as recirculating pumps, controlled valves, cooling system fan rotational speed, etc. Component EE-101 represents an electrical heater that connects the TES to the HP evaporator; If the system works with the configuration that includes the electrical heater it will be possible to keep at the evaporator inlet the same water temperature provided by the panels at the TES inlet. Briefly, the electrical heater acts as a mass flow rate multiplier that allows emulating a major number of solar panels with respect to those installed at the Campus.

Fig. 7 represents the panel circuit's temperature acquisition system.

4. EXPERIMENTAL RESULTS

In the following, the experimental results of the test campaign of the faced panels' integrated systems are reported.

Fig. 9 shows the behavior of two couples of grey and white solar panels installed on the south-west side. In Fig. 8 the related measured solar radiation profile of the test-day (April 27th, 2022) is reported.

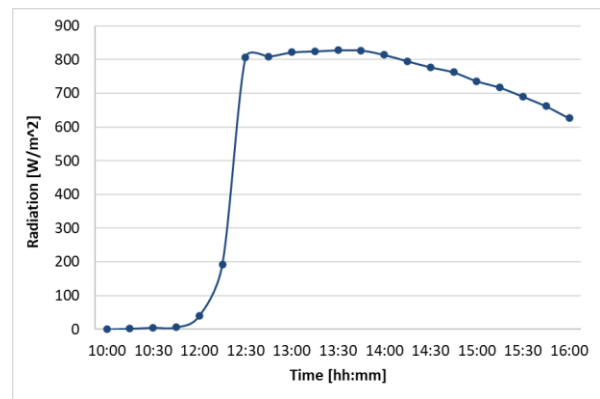

Fig.8 – Solar Radiation Profile

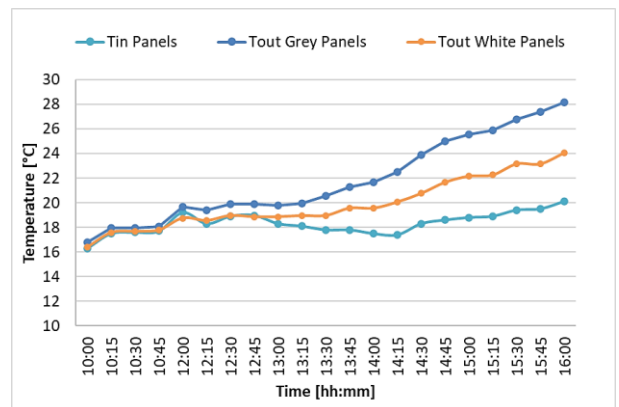

Fig.9 – Grey and White Panel's Temperature Profile

From the analysis of Fig. 9 it is possible to underline that, at the same water inlet temperature, the grey panels can provide a greater temperature difference with respect to the white ones. In fact, grey panels increase the water temperature of about 8°C whereas the white ones increase it of about 4.5°C. This difference is due to the different absorption capacity of solar radiation of the two paints that cover the panels. In Fig.10, the global water flow, equally subdivided through each of the 17 panels' couple, is reported.

During the test, the recirculating pump has been kept at its minimum rotational speed in order to have the maximum amount of temperature difference on the panels. The pick at noon represents a transitory behavior associated to the HP startup.

Based on the panels mass flow rate shown in Fig.10 and the temperature increment at the panel outlet (Fig. 9), the thermal power produced by the two panels couple whose total heat transfer area is equal to 2.4 m² is calculated and reported in Fig.10.

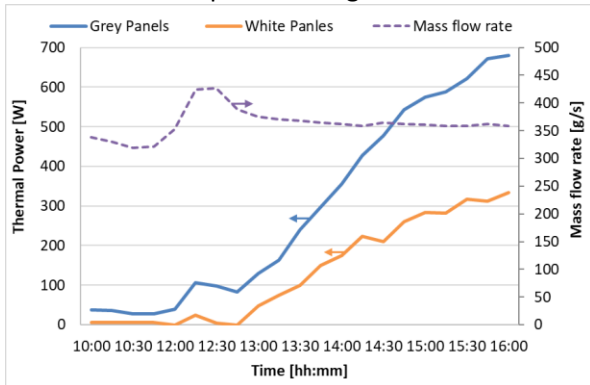

Fig.10 – Solar Panels' Thermal Power Profile [kW] and water mass flow rate

The temperature profile inside the panel's TES, during the test, is reported in Fig.11.

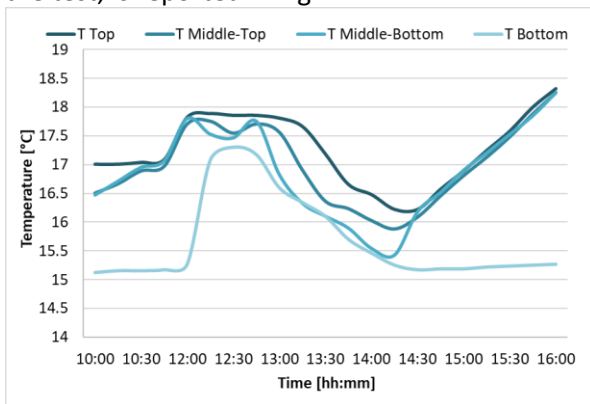

Fig.11 – Panels' TES Temperature Profile

At around 12:30 the TES water temperature started decreasing because of the HP startup: the mass flow rate elaborated by the HP evaporator is higher than the one related to the panels' circuit because this test has been conducted without the auxiliary of the electrical heater. 4 probes have been installed inside the TES to keep into consideration the water temperature stratification inside it [13]. As soon as the evaporator recirculating pump has been started up the TES bottom temperature increased because the water coming from the evaporator inlet point is located in the TES lower part. When the HP has been started up, the temperatures profile started decreasing till the HP and the recirculating pump shut down where only the TES

lower part remains cold: due to density the TES bottom part is the latest one to be heated up.

Fig.12 reports the HP temperature profile during test operation. It is possible to underline the water temperature provided at the condenser is around 50°C, equal to the return water temperature of the Savona Campus DHN. The TES, connected to the solar façade panels' circuit, which instead represent the source at low temperature provides an evaporator water inlet temperature almost equal to 18°C. The test has been carried out in closed loop, dissipating the thermal power produced by the HP using fancooler keeping as set point temperature at the condenser inlet the same temperature usually provided by the DHN return water.

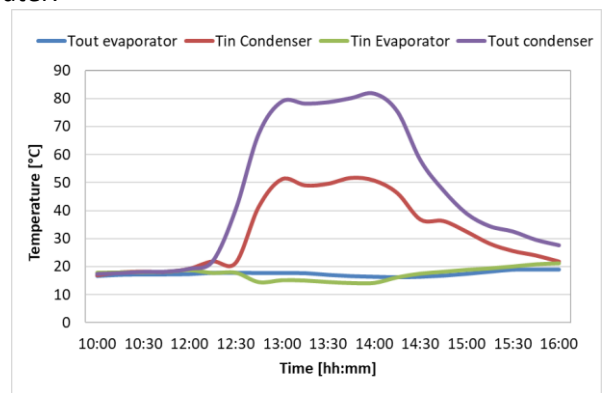

Fig.12 – HP Temperatures

The measured mass flow rate at the evaporator and at the condenser (Fig.14) shows that the one related to the evaporator is almost equal to 1.5 kg/s whereas the condenser one is 0.25 kg/s during the test.

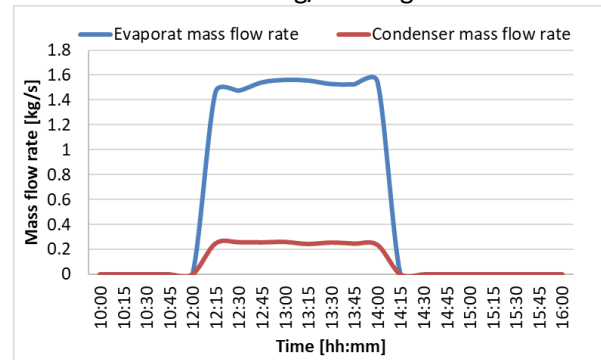

Fig.13 – HP mass flow rates

The HP condenser thermal power calculated through $P[kW] = \dot{m}_{cond} C_p \Delta T$ is about 30 kW (Fig.14).

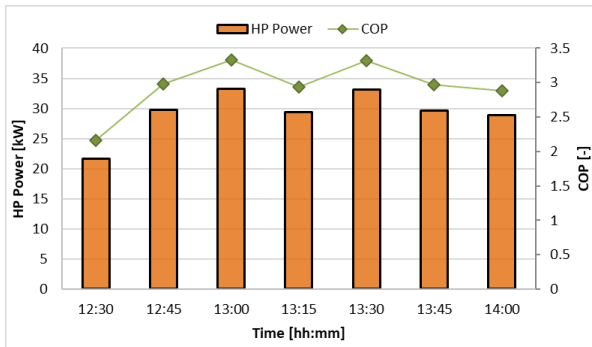

Fig.14– Thermal Power Production and COP of the Heat Pump

Considering that during operation the HP always works at a fixed rotational speed and absorbs 10kWe the corresponding HP COP has been calculated as follow

$$COP[-] = \frac{(\dot{m}_{cond}c_p\Delta T)}{10}$$

The resulting COP is approximately equal to 3 (Fig.14). The percentage increment between the water inlet and outlet temperature related to grey and white solar façade panels is reported in Fig. 15.

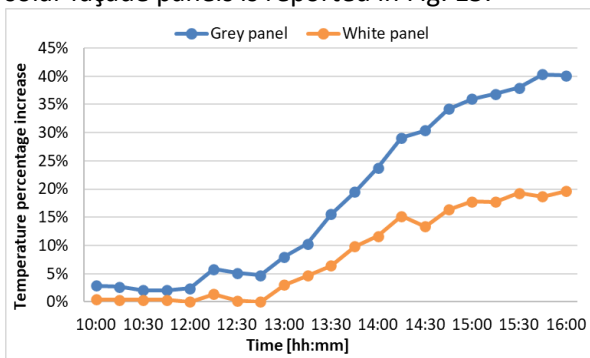

Fig.15 – Panels' outlet temperature increment in percentage over the inlet temperature

5. CONCLUSION

The realized integrated system, based on the use of innovative solar façade panels developed in the framework of 'ENVISION', shows good results in terms of thermal power production and could contribute to achieve the objectives set in the European Green Deal by 2050. The exploitation of all available opaque surfaces of the building proposed by 'ENVISION' will almost double the possibility to produce clean energy from renewables and in the meanwhile to keep the aesthetic of the façade. In the study shown in this paper, the HP operates with high COP which is expected to increase even more as soon as the evaporator inlet temperature will increase and, considering also the development of 4th generation DHN which operates with temperatures around 45°C, a direct use of the 'ENVISION' panels in particularly hot day it is not a utopia. The presence of the mGT ensure

to cover completely the electrical power consumption of the plant and contributes to covering both the electrical and thermal demand of the Savona Campus.

ACKNOWLEDGEMENT

Authors gratefully acknowledge the financial support from the 'EU Framework Programme for Research and Innovation Horizon 2020' under the grant agreement No 767180 (ENVISION), and from the POR FESR Liguria 2014-2020 project – "Sostegno alle infrastrutture di ricerca considerate critiche/cruciali per i sistemi regionali".

REFERENCES

- [1] Luo Y., et al, "Active building envelope systems toward renewable and sustainable energy", Renewable and sustainable energy reviews 104 (470-491), 2019
- [2] Eurostat Database
- [3] EU Buildings Database
- [4] FITS4E Project available on www.projecten.topsectorenergie.nl
- [5] Rossi I., et al, Real-time management solutions for a smart polygeneration microgrid, En Conv Man, vol 112, 2016
- [6] Mario L., et al, Real-time tool for management of smart polygeneration grids including thermal energy storage, Applied Energy, Volume 130, 2014.
- [7] D3.7 Best practices handbook and instruction manual for the guided realization, monitoring, maintenance and adaption of the façade energy harvesting modules in a full renovation concept, ENVISION Project, available on www.energy-envision.eu
- [8] Renuke A., et al, Experimental investigation on a 3-kW air Tesla expander with high speed generator. In: Turbo Expo: Power for Land, Sea, and Air. American Society of Mechanical Engineers, 2020. p. V005T06A006.
- [9] Renuke, A., et al, (2019). Experimental and numerical investigation of small-scale Tesla turbines. Journal of Engineering for Gas Turbines and Power, 141(12), 2019
- [10] Renuke A., et al, Experimental campaign tests on a Tesla micro-expanders. In: E3S Web of Conferences. EDP Sciences, 2019. p. 03015.
- [11] Ferrari M. L., et al, A micro gas turbine based test rig for educational purposes. Journal of engineering for gas turbines and power, 132(2), 2010.

- [12] Ferrari M. L., Pascenti, M., Flexible micro gas turbine rig for tests on advanced energy systems. In *Advances in Gas Turbine Technology* (pp. 89-114), 2011.
- [13] Cuneo, A., et al, State of charge estimation of thermal storages for distributed generation systems. *Energy Procedia*, 61, 254-257, 2014.