

Patch Antenna with Slanted $\pm 45^\circ$ Dual Polarization and Performance Comparison with H/V Diversity

Luigi Vallozzi¹

¹Department of Information Technology, Ghent University, Ghent, Belgium, luigi.vallozzi@ugent.be

Abstract—Polarization diversity is well known to be an efficient technique improving the reliability of wireless communication. Moreover, it is very convenient, in terms of compactness, to have dual polarization on a single antenna instead of two separate radiators. Several *dual polarized antennas* have been therefore proposed by researchers, implementing this concept. In this paper a recently developed dual polarized patch antenna (DPPA) is presented, realized on a multilayer dielectric substrate and possessing a slanted $\pm 45^\circ$ dual polarization, operating around the central frequency $f = 1.35$ GHz. First the design, general performance parameters and polarization properties of the DPPA are presented. Then a novel comparative study between the chosen $\pm 45^\circ$ polarization and the horizontal-vertical (H/V) configuration is performed by means of a ray tracing-based simulation framework, in terms of Bit Error Rate (BER) performance in an indoor wireless communication link using the proposed antenna.

Index Terms—Diversity, dual polarization, indoor, ray tracing.

I. INTRODUCTION

Polarization diversity is a well established technique to improve reliability of wireless communication links using diversity or Multiple-Input Multiple-Output (MIMO) techniques [1], [2]. In wireless communication systems for which compactness of the antennas is a concern, like in *wearable systems* [3] of mobile radio, it is very advantageous to implement dual polarization on a single radiator, rather than on two separate ones. For this reason, several dual polarized antennas have been proposed in the past years by antenna researchers. The author's research group previously proposed a 2.45 GHz dual-polarized patch antenna (DPPA) completely made out of wearable materials, for integration into wearable textile systems, i.e. clothing with added functionalities for monitoring and coordination of rescue workers' interventions [4].

In this manuscript a novel rigid implementation of the wearable DPPA is proposed, for operation around the frequency $f = 1.35$ GHz, and application as an element of a uniform circular antenna array for a channel sounder.

When dealing with conventional rigid substrate materials, the dielectric permittivity is substantially higher with respect to textile substrates, for which ϵ_r is very close to unity. This implies that is more challenging to obtain large reflection coefficient bandwidths compared to the textile case. In order to solve such a problem and obtain bandwidths that are comparable with the one obtained for the textile version of the DPPA, a multilayer substrate structure has been chosen, resulting in an increase of substrate thickness and subsequently an enlargement of the BW to the required value of 50 MHz.

Careful optimization of the geometrical dimensions and feeds' location of the DPPA were performed to ensure operation around the targeted frequency of 1.35 GHz. The dual polarization provided by this antenna in the transmit mode, consists of two nearly linearly-polarized EM waves, corresponding to the signals applied to the two ports, respectively. The two waves, in the broadside direction, are nearly orthogonal in space with tilt angles of $\alpha = \pm 45^\circ$ with respect to the horizontal plane. This results in a high level of polarization mismatch between the two waves, a feature that is highly desirable for implementation of polarization diversity. The design of the proposed DPPA derives from a previously developed prototype, made out of textile materials and intended for wearable applications, reported by the author's group in [4]. Starting from this existing prototype, operating in the 2.45 GHz ISM band, a rescaling of the geometrical dimensions was required in order to ensure resonance at the targeted resonant frequency of 1.35 GHz. Additionally, the use of a conventional rigid dielectric substrate, instead of the textile-based one used in the previous design (polyurethane shock absorbing foam with $\epsilon_r = 1.53$ and thickness $h = 3.94$ mm) had to be taken into account.

The choice of the slanted $\pm 45^\circ$ dual polarization is preferable to the horizontal-vertical (H/V) one (i.e. $\alpha = 0^\circ, 90^\circ$) based on few considerations. In particular, to obtain a higher degree of diversity at the receive side, a low correlation and a low power unbalance between the two received waves, are required. For an indoor multipath propagation scenario, one can expect that the $\pm 45^\circ$ configuration, at the receive side, provides a similar level of decorrelation than the H/V one and, due to the symmetrical nature of the polarization orientations w.r.t. the propagation environment, more similar average received powers, i.e. a lower power unbalance.

The advantage of using the slanted- $\pm 45^\circ$ with respect to the H/V configuration was already demonstrated for wireless cellular communications in urban environment [5], where it was shown that the slanted configuration allows to obtain the highest channel capacity when the number of antennas is less or equal to four. To the author's best knowledge, no similar analysis was done in literature for indoor multipath channels. For this reason, in this paper we propose a comparative performance study between slanted- $\pm 45^\circ$ and H/V dual polarization, used at the receive side of a 1×2 wireless links in and indoor propagation scenario. This is done by comparing the link performance, in terms BER, of the 1×2 Single-Input Multiple-Output (SIMO) link using a receiving DPPA

with the two different polarization's orientation configurations, respectively. Such an analysis is performed by means of a deterministic simulation framework, previously presented in [6].

The paper is organized as follows. In Sec. II the proposed DPPA is treated, starting with the formulation of the design goals, followed by a description of the used design strategy and an overview of the simulated and measured main antenna performance parameters. In Sec. III the comparative study between the chosen $\pm 45^\circ$ polarization and the H/V scheme is described, demonstrating the performance advantages of the first configuration with respect to the second one. Finally, in Sec. IV the conclusions are outlined.

II. DUAL POLARIZED PATCH ANTENNA FOR 1.35 GHz

A. Design goals

The design of the DPPA employed, as a starting point, a previously proposed wearable textile DPPA operating at 2.45 GHz [4]. First the design criteria were set, in terms of S-parameters, polarization proprieties, and bandwidth. We can list them as follows:

1) S-parameters:

$$\begin{cases} \text{Return loss: } |S_{11}|, |S_{22}| < -10 \text{ dB} \\ \text{Isolation: } |S_{21}|, |S_{12}| < -15 \text{ dB} \end{cases} \quad (1)$$

- 2) **Polarization:** polarization ellipses at broadside, for port 1 and 2, nearly linear and with tilt angles $\alpha_1 = +45^\circ$, $\alpha_2 = -45^\circ$
- 3) **Bandwidth:** S-parameter criteria met in a frequency range centered around frequency $f = 1.35$ GHz, wide at least 50 MHz, i.e. $BW > 50$ MHz

B. Design strategy

Two main problems were taken into account and solved during the DPPA design:

- The proposed DPPA must exhibit a different resonant frequency ($f = 1.35$ GHz) with respect to the 2.45 GHz in the reference design in [4]. Assuming the same materials for the new DPPA, a simple rescaling of the geometrical dimensions would be sufficient. Unfortunately, a different substrate material was used, thus additional considerations had to be made, as described in the following point.
- The novel DPPA must be constructed on a rigid dielectric substrate. The commonly on-the-market available ones possess dielectric permittivities that are substantially higher than for the wearable textile substrate used in the reference design, having $\epsilon_r = 1.53$. This implies a reduction of the BW , that is known to be inversely proportional to the permittivity [7]. Moreover, it is also known that the BW of patch antennas is directly proportional to substrate thickness. However, this parameter cannot be freely increased since commercially available substrates' thickness is limited. To circumvent this problem, we implemented a new simple construction technique. This consisted in stacking four identical substrate layers, glued

TABLE I
PARAMETERS OF THE REALIZED ANTENNA

Optimized Parameters	Patch length $L = 71.88$ mm
	Patch Width $W = 72.90$ mm
	Slot Length $L_s = 22.8$ mm
	Feed Points $(\pm x_f, y_f) = (\pm 12.93, 12.93)$ mm
Fixed Parameters	Slot Width $W_s = 1.69$ mm
	Substrate Total Height $h = 10.388$ mm
	Substrate Permittivity (Duroid) $\epsilon_r = 1.96$, $\tan\delta = 0.0019$
	Conductive materials: Copper laminate Substrate material: Duroid 5880 LZ + adhesive bondply

together by means of thin adhesive layers, to increase the total thickness until a sufficient value of BW was reached. As a substrate material, "Duroid 5880 LZ" was chosen, exhibiting one of the lowest available permittivity on the market ($\epsilon_r = 1.96$) and a single-layer thickness of $h_s = 2.54$ mm. Stacking four layers of such a material, a total thickness of about 10 mm was obtained, which appeared to be more than sufficient to meet the criteria on the BW . The substrate layers were assembled by interposing 3 layers of thermal adhesive glue (bondply 2929) with thickness $h_a = 0.076$ mm.

Taking into account these two aspects, first a rough calculation of the geometrical dimensions was performed. After that, a simulation model of the DPPA was constructed by means of ADS Momentum, and an optimization of the geometry was performed, having as parameters the geometrical dimensions as well as the feeds' position. This led to the final antenna dimensions, summarized in Table I. The antenna layout is schematized in Fig. 1 and a picture of the realized prototype is shown in Fig. 2.

C. Antenna performance parameters

The DPPA was characterized in terms of its main performance parameters, by means of both simulation and measurement on the realized prototype, in anechoic environment.

1) *S-parameters:* The reflection coefficients are displayed in Fig. 3. One can see that in both simulation and measurement, S_{11} and S_{22} are smaller than -10 dB, in a bandwidth larger than 50 MHz, satisfying the initial design goals. Moreover, there is a good agreement between measurement and simulation results. Concerning isolation parameters, S_{12} and S_{21} also meet the design goals, remaining smaller than -15 dB in the interval $[1, 1.7]$ GHz, for both simulation and measurement.

2) *Gain patterns:* The 3D gain patterns were determined by means of simulation and measurement in anechoic environment. In Fig. 4 the 2D-cut of the gain pattern on the XZ plane, for antenna port 1, is displayed (a very similar one is obtained for port 2). One can see an excellent agreement between measured and simulated patterns. The maximum achieved gain in the broadside direction, is about 7.3 dBi in the simulation, and about half a dB lower (6.8 dBi) in the measurement, which is more than sufficient for a reliable wireless communication links in indoor environments.

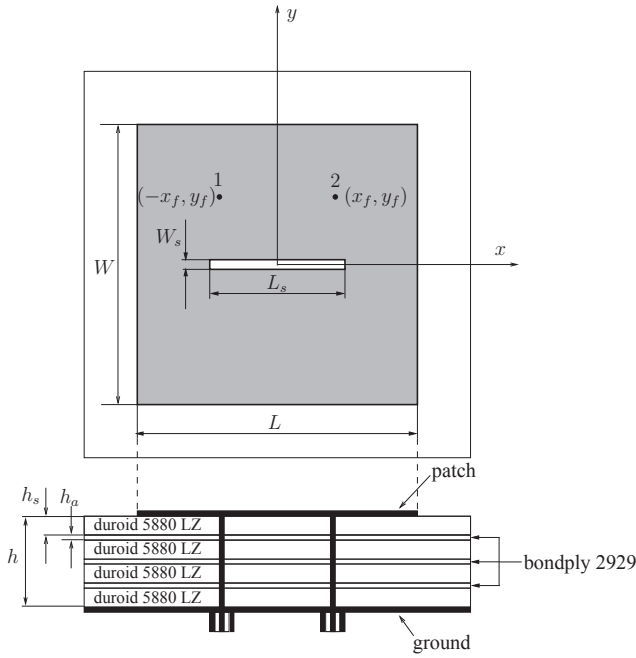

Fig. 1. Scheme of the Dual Polarized Patch Antenna

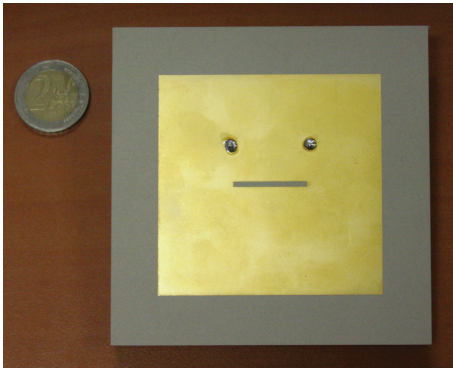

Fig. 2. Picture of the realized DPPA prototype

3) *Polarization*: The polarization of the two port signals was determined as well by means of simulation and measurement. The analysis was performed in terms of *polarization ellipse parameters*, i.e. by characterizing the *tilt angle* α (i.e. the angle between the horizontal axis x and the major axis of the polarization ellipse) and the *axial ratio for linear polarization*, that is defined (in dB) by the relation $AR_{LP} = 20 \cdot \log \frac{1+|\tau|}{1-|\tau|}$, with τ being the ratio between minor and major axis of the polarization ellipse. The polarization parameters in the broadside direction, for both ports, are listed in Table II.

One can see that both simulation and measurement results indicate two nearly orthogonal and linearly polarized signals radiated by the two antenna ports, having tilt angles almost equal to $\pm 45^\circ$, satisfying the design criteria. The axial ratio in dB are about 1 dB, which represents a nearly-ideal linear polarization (i.e. $AR_{LP} = 0$ dB).

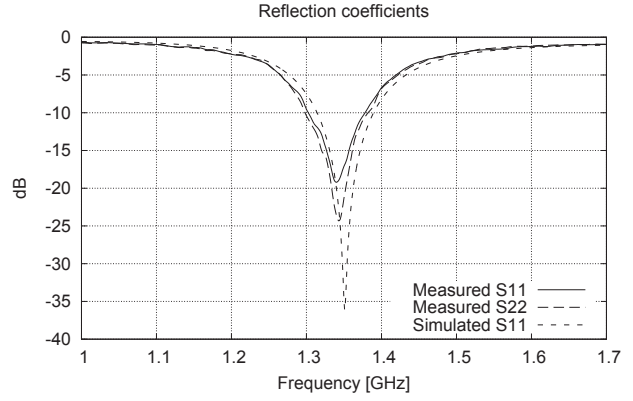

Fig. 3. Measured reflection coefficients

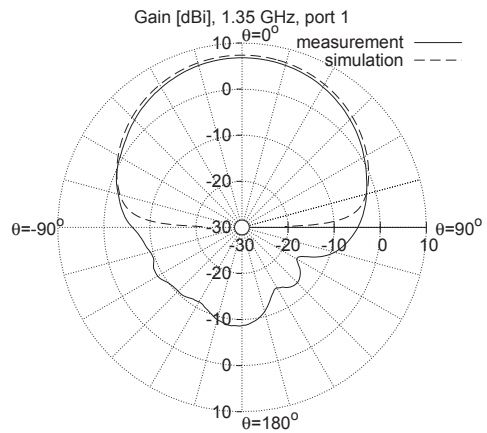

Fig. 4. Simulated and measured gain pattern on the XZ plane, at $f = 1.35$ GHz, for antenna port 1

III. COMPARATIVE ANALYSIS OF SLANTED $\pm 45^\circ$ VS. HORIZONTAL/VERTICAL POLARIZATION DIVERSITY

The chosen slanted $\pm 45^\circ$ dual polarization configuration is reportedly known for its advantages in terms of capacity in outdoor urban propagation [5], in comparison with the H/V orientation scheme. In this paper we present a similar analysis for an indoor propagation environment, performed by means of a simulation framework based on ray tracing channel modeling [6]. By using such a simulation tool, modeling and simulating an indoor digital communication link between a fixed transmit

TABLE II
PARAMETERS OF POLARIZATION ELLIPSES IN THE BROADSIDE DIRECTION, $f = 1.35$ GHz

	Parameter	Port 1	Port 2
measurement	α	44.89°	-43.58°
	$AR_{LP} _{dB}$	0.48	0.59
simulation	α	44.27°	-44.29°
	$AR_{LP} _{dB}$	1.09	1.09

antenna and the proposed DPPA, the advantages of the proposed DPPA with slanted $\pm 45^\circ$ polarization, with respect to a similar DPPA using H/V diversity, are demonstrated.

In particular, a 1×2 wireless communication system in an indoor office environment has been modeled as a case study. The multipath channel model, displayed in Fig. 5, was constructed by means of the WinProp[®] ray-tracing software [8]. The modeled 1×2 link includes a fixed, vertically-

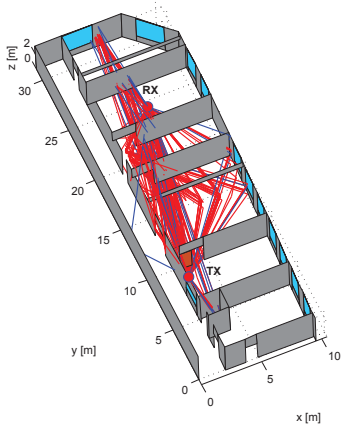

Fig. 5. Indoor multipath channel modeled by means of ray tracing

polarized single-port antenna at the TX side and a DPPA at the RX side, whose position can vary on a given spatial grid of points, as depicted in the scheme in Fig. 6. In our analysis the dual polarized RX antenna is facing the TX antenna, i.e. its broadside direction is oriented along the $-\hat{y}$ direction of the fixed reference system. In order to switch between the two considered polarization configurations $\pm 45^\circ$ and H/V , the RX DPPA antenna was rotated of an angle of 45° around its \hat{z}_{rx} axis, as displayed in Fig. 7. The communication link

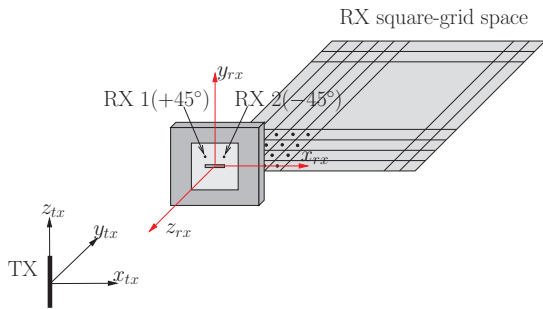

Fig. 6. Scheme of the link between TX and RX antennas with their orientation and the grid of RX locations used in the simulation

and its performance have been modeled with the aid of the simulation framework previously developed by the author's group, whose complete description was presented in [6], for which we recall here only the most important features. In particular, the modeling and simulation framework consists in the combined use of 3 tools, in particular:

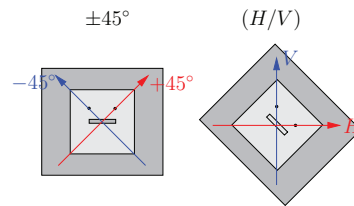

Fig. 7. Scheme of the two polarization configurations obtained by rotating the DPPA of an angle of 45°

- *Full-wave 3D EM solver*, providing the full 3D radiation vector patterns of TX and RX antennas, i.e. $\vec{F}_\theta(\theta, \phi)$, $\vec{F}_\phi(\theta, \phi)$.
- *Ray Tracing*, used for the deterministic modeling and calculation of the propagation channel responses. Combining its results with the antennas' radiation vector patterns, it is possible to obtain the channel gains. In our case, we obtain 2 channel gains (for the two RX polarizations) as a function of the RX antenna's location on the considered grid of N points, i.e. $h_1(i), h_2(i)$, $i = 1, \dots, N$.
- *Monte Carlo simulation*, simulating a digital transmission of symbols through the calculated AWGN channels, considering MRC combining at the RX side. This provides as a main result the BER curve of the 1×2 communication link.

Moreover, the knowledge of the channel gains allows to calculate their mean powers $E_{b,1}, E_{b,2}$ and their mutual power-correlation ρ_P . The mean powers represent the squared absolute values of the channel, averaged over the considered spatial locations of the RX antenna, that is $E[|h_1|^2], E[|h_2|^2]$. In a communication link employing diversity, it is advisable to have a low channel unbalance between the channels. The performance of the system in terms of quality (BER) are maximum if the channel powers are identical, that is when there is no power unbalance between the channels.

The power-correlation coefficient represents an indication of how correlated are the channels with respect to each other, and it is given by the relationship:

$$\rho_P = \frac{E[|h_1|^2|h_2|^2] - E[|h_1|^2]E[|h_2|^2]}{\sqrt{(E[|h_1|^2] - (E[|h_1|])^2)(E[|h_2|^2] - (E[|h_2|])^2)}}$$

The values of the power-correlation coefficient can vary in the interval $[0, 1]$, holding $\rho_P = 0$ for completely decorrelated signals and $\rho_P = 1$ for maximally correlated ones. The lower is the value of ρ_P , the better is the BER performance of the diversity system.

The BER curves of the 1×2 link were then computed, by considering the two different polarization configurations for the RX DPPA antenna, and compared. In Fig. 8 the resulting BER curves are shown. One can see that the best performance, corresponding to the lowest values of BER, is achieved when the proposed DPPA with slanted $\pm 45^\circ$ polarization is used at the RX side, in contrast to the case of a DPPA with H/V polarization. In addition, we report in Table III the channels'

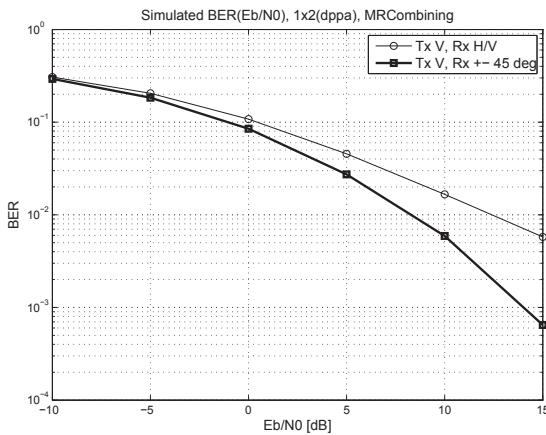

Fig. 8. Simulated BERs of a 1×2 indoor wireless communication system, for the two compared polarization orientations of the RX antenna, facing the TX antenna.

TABLE III
SIMULATED CHANNEL POWERS AND POWER-CORRELATION COEFFICIENTS, FOR THE TWO CONSIDERED POLARIZATION CONFIGURATIONS

RX pol.	$\pm 45^\circ$	H-V
Powers [μW]	$E_{b,1} = 1.23$ $E_{b,2} = 1.35$	$E_{b,1} = 2.36$ $E_{b,2} = 6.38$
Correlation ρ_P	0.95	0.99

power-correlation coefficients and their powers. Based on these results, one can make some considerations in relation to the obtained BER results. The power unbalance (i.e. the difference in power between the two channels) is substantially different for the two considered polarization configurations (i.e. $\pm 45^\circ$ and H/V): the H/V configuration is characterized by a substantially higher channels' power unbalance than the $\pm 45^\circ$ one, for which the channel powers almost equal.

For both polarization configurations the simulated correlation values are relatively high and very similar ($\rho_P = 0.95$ for $\pm 45^\circ$ and $\rho_P = 0.99$ for H/V).

Therefore, according to the constructed simulation model, the main factor determining better performance of the $\pm 45^\circ$ configuration, is represented by the remarkably lower power unbalance of this configuration with respect to the H/V one, proving our initial intuitive considerations.

IV. CONCLUSION

In this paper a novel dual polarized patch antenna (DPPA) with slanted $\pm 45^\circ$ is proposed, for operation around the frequency $f = 1.35$ GHz wireless communications link employing dual polarization diversity. In order to circumvent the problem represented by a relatively narrow bandwidth, caused by the high permittivity and limited thickness of commonly available rigid substrate materials, we implemented a multilayer substrate assembling technique. In particular, by stacking 4 layers of duroid substrate on each other, glued by interposed bondply adhesive layers, a relatively large return

loss bandwidth was achieved, with a bandwidth larger than the targeted value of 50 MHz. The proposed antenna has been realized and fully characterized by simulation and measurement. Performance show the capability of independently receive/transmit two orthogonal linearly polarized signals, oriented at tilt angle of about $\pm 45^\circ$, as well as a sufficient value of gain to establish a reliable indoor communication link.

After that, a comparative study has been performed in order to demonstrate the advantage of the proposed slanted $\pm 45^\circ$ configuration with respect to H/V orientation. The analysis was carried out by using a deterministic simulation framework using ray tracing and Monte Carlo simulations, to model a digital data transmission through the indoor link between a base station and the proposed DPPA. The analysis clearly showed the advantages, in terms of received BER, of using the proposed DPPA with slanted $\pm 45^\circ$, rather than a similar antenna employing H/V dual polarization. The factor determining better performance of the $\pm 45^\circ$ configuration, is represented by the remarkably lower power unbalance of this configuration with respect to the H/V one, proving our initial intuitive considerations.

Future work may consist in the investigation of influence on link performance of the relative antennas' orientation on the horizontal plane, as well as considering links using higher orders of diversity. Moreover, experimental characterization can be useful in order to confirm and validate the results predicted by the employed modeling framework.

ACKNOWLEDGEMENTS

The author would like to thank dr. Emmeric Tanghe of the WiCa group at Ghent University, for his valuable advice during the antenna design phase.

REFERENCES

- [1] J. J. A. Lempiainen and J. K. Lahio-Steffens, "The Performance of Polarization Diversity Schemes at a Base Station in Small/Micro Cells at 1800 MHz," *IEEE Trans. Vehicular Technology*, vol. 47, no. 3, pp. 1087–1092, Aug. 1998.
- [2] T. Svantesson, M. A. Jensen, and J. W. Wallace, "Analysis of electromagnetic field polarizations in multiantenna systems," *IEEE Trans. Wireless Comm.*, vol. 3, no. 2, pp. 641–646, Mar. 2004.
- [3] A. Lymberis, "Advanced wearable sensors and systems enabling personal applications," in *Wearable and Autonomous Biomedical Devices and Systems for Smart Environment*, ser. Lecture Notes in Electrical Engineering, A. Lay-Ekuakille and S. Mukhopadhyay, Eds. Springer Berlin Heidelberg, 2010, vol. 75, pp. 237–257.
- [4] L. Vallozzi, H. Rogier, and C. Hertleer, "Dual Polarized Textile Patch Antenna for Integration into Protective Garments," *IEEE Antennas Wireless Prop. Lett.*, vol. 7, pp. 440–443, 2008.
- [5] K. Nishimori, Y. Makise, M. Ida, R. Kudo, and K. Tsunekawa, "Channel capacity measurement of 8×2 mimo transmission by antenna configurations in an actual cellular environment," *Antennas and Propagation, IEEE Transactions on*, vol. 54, no. 11, pp. 3285–3291, 2006.
- [6] L. Vallozzi and H. Rogier, "Off-body wireless link simulation framework using deterministic channel modeling," in *Antennas and Propagation (EuCAP), 2014 8th European Conference on*, April 2014, pp. 2289–2293.
- [7] C. A. Balanis, *Antenna Theory: Analysis and Design*, 2nd ed. New York: John Wiley & Sons, 1997.
- [8] AWE-Communication website: <http://www.awe-communications.com/>.