



***Rhipicephalus appendiculatus/zambeziensis* complex  
from southern and eastern Zambia: genetic and  
phenotypic diversity related to the associated  
variation of the epidemiology of bovine theileriosis.**

Proefschrift ter verkrijging van de graad van doctor in de  
diergeneeskundige wetenschappen aan de faculteit  
diergeneeskunde  
Universiteit Gent, 2008

**Jupiter MTAMBO**

Promotoren  
Prof. Dr. P. Dorny  
Prof. Dr. T. Backeljau  
Dr. M. Madder

Vakgroep Virologie, Parasitologie en Immunologie  
Faculteit Diergeneeskunde, Universiteit Gent  
Salisburylaan 133, B-9820 Merelbeke





## **Dedication**

This one is for my father (late) and mother, not because they will ever understand any of this, but because of the encouragement they gave me in “all things school” in those crucial initial years despite the fact that they themselves had little (father) or no (mother) education. If I were to live again and had a choice, I would choose you with your particular strengths and weaknesses.



## **Acknowledgements**

This work comes to fruition trailing clouds of kindness of many institutions and people that deserve formal recognition for their help, support and accessibility throughout the period of my studies.

Firstly, I extend a special thank you to my ITMA supervisor Dr. Maxime Madder, who gave me a lot of latitude in both the conceptualization and the execution of this study. Maxime, also had the unenviable task of going through my manuscripts, warm from the oven of my mind (read as confused), before any one else went through them! They came back expeditiously and... cool of course! For this I am grateful. A great deal of thanks must also go to Dr. Wim van Bortel and Patricia Roelants of the Entomology section of the Parasitology department and Pim de Rijk of the Mycobacteriology laboratory. Wim was especially helpful in the early stages when I was trying to come to terms with molecular techniques. He provided me access to additional web based resources (like BEN) without which some aspects of this study would have been impossible. Patricia was responsible for introducing me to the dos and don'ts of molecular biology laboratory practice. Both Wim and Patricia and indeed the whole entomology section laboratory group provided an amiable atmosphere, just what I needed especially in those initial stages when the "PCRs did not work." Pim's extensive experience in molecular biology laboratory techniques came in handy not a few times and I owe my first successful DNA sequence alignment to his tutelage.

I cannot fully express my gratitude to my promoters Profs. Pierre Dorny and Thierry Backeljau. Prof. Dorny is thanked for facilitating my "return" to Antwerp, his helpful suggestions during the course of studies and his natural calming and assuring influence when things were bad. Prof. Backeljau is especially thanked for his patience in reading every single component of this thesis and his invaluable comments, contributions and useful remarks. I am further grateful to him for securing for me those difficult-to-find software packages and references.

May I also express my sincere appreciations to all members of staff of the Animal Health Department of the ITMA for their support in many and diverse ways. Viviane and Monique are thanked for their patience with my late knocking off and always reminding me of public holidays. Daniele De Bois deserves hearty thanks for ably

handling all the administrative aspects of my study. Bjorn and his lab crew are thanked for their efficiency in ordering stuff and their friendship. I thank all the teaching staff for their contributions, remarks and suggestions especially during presentations. Special thanks to Dr. Tanguy Marcotty for his incredible commitment to the success of what came to be called the “Zambian PhD group”. Even in the face of personal calamity your commitment was unwavering! Thanks are also due to Dr. N. Speybroeck (St.Niklass) for that treasure trove of references you availed to me. You were really God sent!

This work would not have seen the light of day had it not been for the determination and foresight of Prof. ir. Dirk Berkvens and Dr. Mulumba. I thank you both for all the time you spent on the ASVEZA project in general and the Zambian PhD programme in particular and for believing in me personally and consequently granting me the opportunity to take a shot at this PhD study. This definitely was not a birdie but I hope I did not, as it were, abuse your trust.

I extend my thanks to Dr. Peter Gilbert Sinyangwe the Director of the Department of Veterinary and Livestock Development for his encouragement in the course of the study by periodically checking on our (my colleagues and I) progress and facilitation of my study leave.

I should also additionally thank my PhD friends and colleagues (past and present) in the department and the Institute in general for their camaraderie, i.e. Chola Shamputa and Anthony Ablordey (Mycobacterium lab), Paul Fandamu, Baba Soumare, Justin Masumu (chief), Victor Mbao, Christopher Kubi, Nynke Deckers, Amel Abdel and Akoda G. Komlan.

I would like to acknowledge, Chaka George, Mataa Liywalii, Mostin Laurent, Penne Koert, Billiouw Michel, Elyn Rik, Mulenga Patrick, Henry Chungu (late), Bubala Desmond, Keembela Valentine, Nyambe Robert Ita, Hadobe Oliver , Chikandi Evans, Chimbala Gerald, Banda Victor, Syandebwe Dixon and many others from the former ASVEZA project for their generous assistance in research and field work. I equally lift my hat off to the farmers especially Mr. Bbuku of Nteme and the farmer group at Halubilo who allowed us (ASVEZA project) to use their herds for research.

My social and spiritual life would have been pathetic if it were not for the many friends I met at Antwerp Christian Fellowship. I shall always treasure the friendship

of the Rev. William Martin and his wife Deborah, Steve and Linda Petra, family Seth van Herck and Gracina, Craig and Heather Wallis, Denise Gormley, Agnita Souman, Dorothy Tanyi, Pauline Aguire, Ian MacBeath, Paul Kattepogu and Geovanna Benedictis to mention just a few. You guys meant Antwerp to me! Ann Schervenels and Helga Bodes of the student service are thanked too for their every effort made towards this work.

I am grateful to the Belgium Government for funding my study through the Belgium Technical Cooperation (BTC) to the Government of the Republic of Zambia in the context of the project “Assistance to the Veterinary Services of Zambia (ASVEZA) in Southern, Central and Eastern provinces”. I thank Mr. Thierry Copin at the BTC for his able administration of the disbursement of the funds.

Finally, I wish to thank “Biggie” and all members of my family for their support. Munsaka Chami Syatwiinda for her patience and love.





<b>CHAPTER 1 - GENERAL INTRODUCTION</b>	<b>1</b>
<b>1.1 Introduction</b>	<b>2</b>
<b>1.2 <i>Theileria parva</i></b>	<b>2</b>
1.2.1 Life cycle of <i>T. parva</i>	3
<b>1.3 The disease (East Coast fever)</b>	<b>5</b>
1.3.1 The mammalian host	5
1.3.2 The distribution of ECF	5
1.3.3 The epidemiology of ECF	7
1.3.4 The control of ECF	8
<b>1.4 The vectors</b>	<b>9</b>
1.4.1 Systematic relationship of <i>R. appendiculatus</i> and <i>R. zambeziensis</i> to other ticks	9
1.4.2 The Genus <i>Rhipicephalus</i>	11
1.4.3 General life cycle of <i>R. appendiculatus</i> and <i>R. zambeziensis</i>	12
<b>1.5 <i>Rhipicephalus appendiculatus</i> and <i>R. zambeziensis</i> in Zambia</b>	<b>14</b>
1.5.1 The vegetation of Zambia	15
1.5.2 Agro-ecological zones of Zambia	15
<b>1.6 References</b>	<b>18</b>
<b>CHAPTER 2 - A REVIEW OF VARIATION WITHIN AND BETWEEN <i>R. APPENDICULATUS</i> AND <i>R. ZAMBEZIENSIS</i></b>	<b>25</b>
<b>2.1 Introduction</b>	<b>26</b>
<b>2.2 Why study variation?</b>	<b>26</b>
<b>2.3 Intra-specific variation</b>	<b>27</b>
<b>2.4 Species concepts</b>	<b>28</b>
2.4.1 Morphological species concept (MSC)	28
2.4.2 Phenetic species concept (PhSC)	29
2.4.3 The biological species concept (BSC)	30
2.4.4 The evolutionary species concept (ESC)	30
2.4.5 The phylogenetic species concept (PSC)	31
<b>2.5 Speciation</b>	<b>32</b>
2.5.1 Geographic speciation	32
<b>2.6 Reconstructing speciation</b>	<b>35</b>
2.6.1 Neighbour-joining	36
2.6.2 Maximum parsimony	36
2.6.3 Maximum likelihood	37

2.6.4	Non-parametric bootstrapping	38
2.6.5	Bayesian inference of phylogeny	39
2.6.6	Choice of gene sequence to use in reconstruction of speciation	39
<b>2.7</b>	<b>Phenotypic variation within and between <i>R. appendiculatus</i> and <i>R. zambeziensis</i></b>	<b>42</b>
2.7.1	Morphological variation	42
2.7.2	Morphological description of <i>Rhipicephalus appendiculatus</i>	43
2.7.3	Morphological description of <i>R. zambeziensis</i>	47
2.7.4	Morphological variation between <i>R. appendiculatus</i> and <i>R. zambeziensis</i>	49
2.7.5	Cellular variation	50
2.7.6	Biochemical variation	50
2.7.7	Behavioural variation	51
2.7.8	Phenology	54
2.7.9	Ecological variation	55
2.7.10	Distribution	55
2.7.11	Life cycle traits	57
<b>2.8</b>	<b>Genetic variation</b>	<b>57</b>
2.8.1	Source and nature of genetic variation	57
2.8.2	Genetic variation within <i>R. appendiculatus</i>	57
2.8.3	Genetic variation within <i>R. zambeziensis</i>	57
2.8.4	Genetic variation between <i>R. zambeziensis</i> and <i>R. appendiculatus</i>	58
<b>2.9</b>	<b>Conclusion</b>	<b>58</b>
<b>2.10</b>	<b>References</b>	<b>59</b>
<b>CHAPTER 3 -</b>	<b>OBJECTIVES OF THE STUDY</b>	<b>69</b>
<b>3.1</b>	<b>Introduction</b>	<b>70</b>
<b>3.2</b>	<b>General objectives</b>	<b>71</b>
<b>3.3</b>	<b>Specific objectives</b>	<b>71</b>
<b>3.4</b>	<b>References</b>	<b>72</b>
<b>CHAPTER 4 -</b>	<b>PHENOTYPIC COMPARISON OF THREE RHIPICEPHALID TICK STOCKS FROM ZAMBIA</b>	<b>75</b>
<b>4.1</b>	<b>Introduction</b>	<b>76</b>
<b>4.2</b>	<b>Materials and Methods</b>	<b>77</b>
4.2.1	Tick stocks	77
4.2.2	Morphological identification, Scoring and Measurements	78
4.2.3	Life cycle traits	78
4.2.4	Statistical analysis	78

<b>4.3</b>	<b>Results</b>	<b>79</b>
<b>4.4</b>	<b>Discussion</b>	<b>84</b>
<b>4.5</b>	<b>References</b>	<b>88</b>

**CHAPTER 5 - INTRASPECIFIC VARIATION IN *RHIPICEPHALUS APPENDICULATUS* FROM EASTERN AND SOUTHERN PROVINCES 91**

<b>5.1</b>	<b>Introduction</b>	<b>92</b>
<b>5.2</b>	<b>Materials and Methods</b>	<b>93</b>
5.2.1	Sampling	93
5.2.2	Identification of ticks and DNA extraction	95
5.2.3	PCR amplification, DNA sequencing and alignment	95
5.2.4	Phylogenetic analysis	96
<b>5.3</b>	<b>Results</b>	<b>96</b>
5.3.1	PCR amplification and sequence alignment statistics	96
5.3.2	Phylogenetic analysis	97
<b>5.4</b>	<b>Discussion</b>	<b>98</b>
<b>5.5</b>	<b>References</b>	<b>102</b>

**CHAPTER 6 - CORRELATING GENETIC AND ECOLOGICAL VARIATION IN *RHIPICEPHALUS APPENDICULATUS* FROM ZAMBIA WITH *R. APPENDICULATUS* FROM EASTERN AND SOUTHERN AFRICA 105**

<b>6.1</b>	<b>Introduction</b>	<b>106</b>
<b>6.2</b>	<b>Materials and Methods</b>	<b>108</b>
<b>6.3</b>	<b>Results</b>	<b>110</b>
<b>6.4</b>	<b>Discussion</b>	<b>113</b>
<b>6.5</b>	<b>References</b>	<b>117</b>

**CHAPTER 7 - INTRASPECIFIC VARIATION IN *RHIPICEPHALUS ZAMBEZIENSIS* FROM SOUTHERN PROVINCE BASED ON MITOCHONDRIAL 12S RDNA 121**

<b>7.1</b>	<b>Introduction</b>	<b>122</b>
<b>7.2</b>	<b>Materials and Methods</b>	<b>123</b>
7.2.1	Study Area	123
7.2.2	DNA sequences	123
7.2.3	Alignment and phylogenetic analysis	123
<b>7.3</b>	<b>Results</b>	<b>124</b>

<b>7.4 Discussion</b>	<b>126</b>
<b>7.5 References</b>	<b>128</b>

**CHAPTER 8 - USING PHYLOGENETIC METHODS TO ASSESS RELATIONSHIPS BETWEEN THE DIFFERENT ECOLOGICAL STOCKS OF *R. APPENDICULATUS* AND *R. ZAMBEZIENSIS* FROM EASTERN AND SOUTHERN ZAMBIA** **131**

<b>8.1 Introduction</b>	<b>132</b>
<b>8.2 Materials and Methods</b>	<b>133</b>
8.2.1 Study area	133
8.2.2 Ticks	133
8.2.3 Morphological identification	134
8.2.4 DNA extraction, PCR amplification and nucleotide sequencing	134
8.2.5 Sequence assembly, Blasting and Multiple Alignments	134
8.2.6 Phylogenetic analysis	135
8.2.7 Development of diagnostic PCR-RFLP markers	135
8.2.8 DNA template for PCR-RFLP	136
<b>8.3 Results</b>	<b>136</b>
<b>8.4 Discussion</b>	<b>146</b>
<b>8.5 References</b>	<b>149</b>

**CHAPTER 9 - COMPARISON OF THE QUALITY OF DNA EXTRACTED FROM PRESERVED *RHIPICEPHALUS APPENDICULATUS* MATERIAL FOR PCR AMPLIFICATION** **153**

<b>9.1 Introduction</b>	<b>154</b>
<b>9.2 Materials and Methods</b>	<b>154</b>
9.2.1 Ticks	155
9.2.2 DNA extraction	156
9.2.3 Amplification	157
9.2.4 Statistical analysis	158
<b>9.3 Results</b>	<b>159</b>
<b>9.4 Discussion</b>	<b>160</b>
<b>9.5 References</b>	<b>164</b>

**CHAPTER 10 - IS *RHIPICEPHALUS ZAMBEZIENSIS* PRESENT IN EASTERN PROVINCE? APPLICATION OF THE PCR-BAUI IDENTIFICATION TOOL TO A COLLECTION OF SPECIMENS OF *RHIPICEPHALUS* SPP. FROM EASTERN PROVINCE** **167**

<b>10.1</b>	<b>Introduction</b>	<b>168</b>
<b>10.2</b>	<b>Materials and Methods</b>	<b>168</b>
10.2.1	Study area	168
10.2.2	Ticks	169
10.2.3	Molecular techniques	169
<b>10.3</b>	<b>Results</b>	<b>170</b>
<b>10.4</b>	<b>Discussion</b>	<b>170</b>
<b>10.5</b>	<b>References</b>	<b>172</b>
 <b>CHAPTER 11 - GENERAL DISCUSSION</b>		 <b>173</b>
<b>11.1</b>	<b>Introduction</b>	<b>174</b>
<b>11.2</b>	<b>Phenotypic variation in <i>R. appendiculatus</i> and <i>R. zambeziensis</i> stocks from Zambia</b>	<b>177</b>
<b>11.3</b>	<b>Genetic intraspecific variation in <i>R. appendiculatus</i> stocks from Zambia</b>	<b>180</b>
<b>11.4</b>	<b>Intraspecific genetic variation in <i>R. appendiculatus</i> from Zambia compared to stocks from eastern and southern Africa</b>	<b>182</b>
<b>11.5</b>	<b>Intraspecific genetic variation in <i>R. zambeziensis</i> from Southern province</b>	<b>184</b>
<b>11.6</b>	<b>Phylogenetic relationships of the different <i>R. appendiculatus</i>/ <i>R. zambeziensis</i> stocks from Zambia</b>	<b>185</b>
<b>11.7</b>	<b>Comparison of preserved <i>R. appendiculatus</i> material for quality of DNA isolated for use in PCR techniques</b>	<b>187</b>
<b>11.8</b>	<b>Development of PCR-RFLP tool for the discrimination of <i>R. appendiculatus</i> and <i>R. zambeziensis</i></b>	<b>189</b>
<b>11.9</b>	<b>Preliminary search for <i>R. zambeziensis</i> in Eastern province using the <i>BauI</i> PCR-RFLP tool</b>	<b>191</b>
<b>11.10</b>	<b>Conclusions and future prospects</b>	<b>191</b>
11.10.1	Tick ecology and evolution	192
11.10.2	Epidemiology	193
<b>11.11</b>	<b>Future research</b>	<b>194</b>
<b>11.12</b>	<b>References</b>	<b>195</b>
 <b>CHAPTER 12 - SUMMARY</b>		 <b>201</b>
 <b>CHAPTER 13 - SAMENVATTING</b>		 <b>209</b>



## List of Definitions

1. **Ancestral (primitive or plesiomorphic):** this is a trait (character state) in a taxon that is present in the common ancestor of all the taxa under study.
2. **Autapomorphy:** a unique derived character state that is absent in the ancestral taxon and other descendants.
3. **Convergency or convergent evolution:** this is the independent evolution of the same feature in different taxa which feature is different in the ancestral taxon. Therefore convergent characters are those that have evolved independently in the taxa under study and differ with the state in their ancestor.
4. **Demes:** subpopulations of a population which may be partially isolated from each other.
5. **Disruptive selection:** this is a pattern of evolutionary change seen in traits controlled by many genes (polygenic) and refers to a situation where both extreme forms of the trait have a higher fitness than does the intermediate resulting in increase of extreme forms and loss of intermediate forms.
6. **Genetic drift:** change in allele frequencies due to random sampling in every generation.
7. **Genetic revolution:** refers to genetic events that may follow colonization by a small number of founders, coupled with genetic isolation of the ancestral population.
8. **Homology:** refers to similarity in character states in more than one taxon because they all inherited that trait directly from their ancestor that had that feature too.
9. **Management units:** this concept has been used in commercial fisheries and refers to stocks that are “demographically autonomous” towards which harvesting quotas and other management plans are directed. Demographic autonomy is suggested when con-specific populations are not clearly delimited by large phylogenetic gaps.

10. **Monophyletic:** a monophyletic clade is a grouping of all descendants of an ancestral taxon.
11. **Non-monophyletic:** a non-monophyletic group omits some descendants of an ancestral taxon. Non-monophyletic group can be paraphyletic or polyphyletic.
12. **Orthologous genes:** these are homologous genes in different species that have started a separate evolution because of speciation.
13. **Paralogous genes:** these are homologous genes that have themselves undergone duplication.
14. **Paraphyletic taxa:** these are groupings based on shared primitive (ancestral) characters and therefore exclude some would be members of the group that have autapomorphies.
15. **Plasticity:** variable phenotypic (morphology, behaviour, physiology) expression of a genotype in response to changes in environmental conditions
16. **Polyphyletic taxa:** taxa that have been erroneously grouped on the basis of convergent characters.
17. **Population bottleneck:** rapid and severe decrease in the number of individuals of a population.
18. **Quantitative traits** (also called polygenic traits): refers to continuous variable traits determined by a large number of genes called quantitative trait loci (QTLs) acting in concert each of which adds a little to the overall variance.
19. **Sibling species:** morphologically and ecologically very similar species that are still separate species.
20. **Sink populations:** refers to ephemeral populations that are “restocked” or re-colonized periodically from relatively stable centres of origin.



# **Chapter 1 - GENERAL INTRODUCTION**

## 1.1 Introduction

Ticks are ubiquitous arthropods that are all at some stage in their life cycle obligate blood-feeding ectoparasites. During feeding ticks may transmit diseases to their hosts. It is for this reason that ticks are of profound veterinary and medical importance (Sonenshine, 1991). As a consequence many aspects of tick biology, including tick ecology have been studied in considerable detail (Klompen *et al.*, 1996).

The ticks *Rhipicephalus appendiculatus* Neumann 1901, *Rhipicephalus zambeziensis* Walker, Norval and Corwin, 1981 and to a lesser extent *Rhipicephalus duttoni* Neumann 1907, are the only known field vectors of *Theileria parva* Theiler 1904, the causative agent of a cattle disease, East Coast fever (ECF) (Lounsbury, 1904; Neitz, 1955; Lawrence *et al.*, 1983). East Coast fever is one of the most devastating livestock diseases in east, central and southern Africa, and remains the major health hindrance to the development and improvement of the livestock industry (Norval *et al.*, 1992a). The livestock industry loses approximately US\$168 million annually (calculated in 1989) due to high mortality and other costs associated with preventing and controlling the disease (Norval *et al.*, 1992b). Kivaria (2006) estimated that the total annual cost of tick borne diseases in Tanzania was US\$ 364 million of which 68% was attributed to ECF. In another study in Tanzania, Kivaria *et al.* (2007), have estimated that the total losses annually per cow based on 2001 prices due to ECF mortality, morbidity and control and prevention practices to be at US\$ 205.40

## 1.2 *Theileria parva*

Levine *et al.* (1980) revised the classification of protozoa based mainly on ultrastructural studies and have classified *T. parva* as a protozoan belonging to the phylum Apicomplexa, class Sporozoa (sporozoite forming), subclass Piroplasmia (piroform parasites), order Piroplasmida (asexual and sexual reproduction), family Theileriidae (Schizonts in lymphocytes) and genus *Theileria* (piroplasms in erythrocytes, lack pigment). Recently, Adl *et al.* (2005) have revised the classification based on morphology, biochemistry and molecular phylogenetics, in which *T. parva* (and other unicellular eukaryotes) are designated Protists rather than protozoa but still remain members of the Apicomplexa. Members of the Apicomplexa are parasites of man and animals. Animals parasitized by *T. parva* are cattle and wild bovidae e.g. the

African Cape buffalo (*Syncerus caffer*), the blue wildebeest (*Connochaetes taurinus*) and, eland (*Taurotragus oryx*) (Burridge, 1975; Lessard *et al.*, 1990).

### 1.2.1 Life cycle of *T. parva*

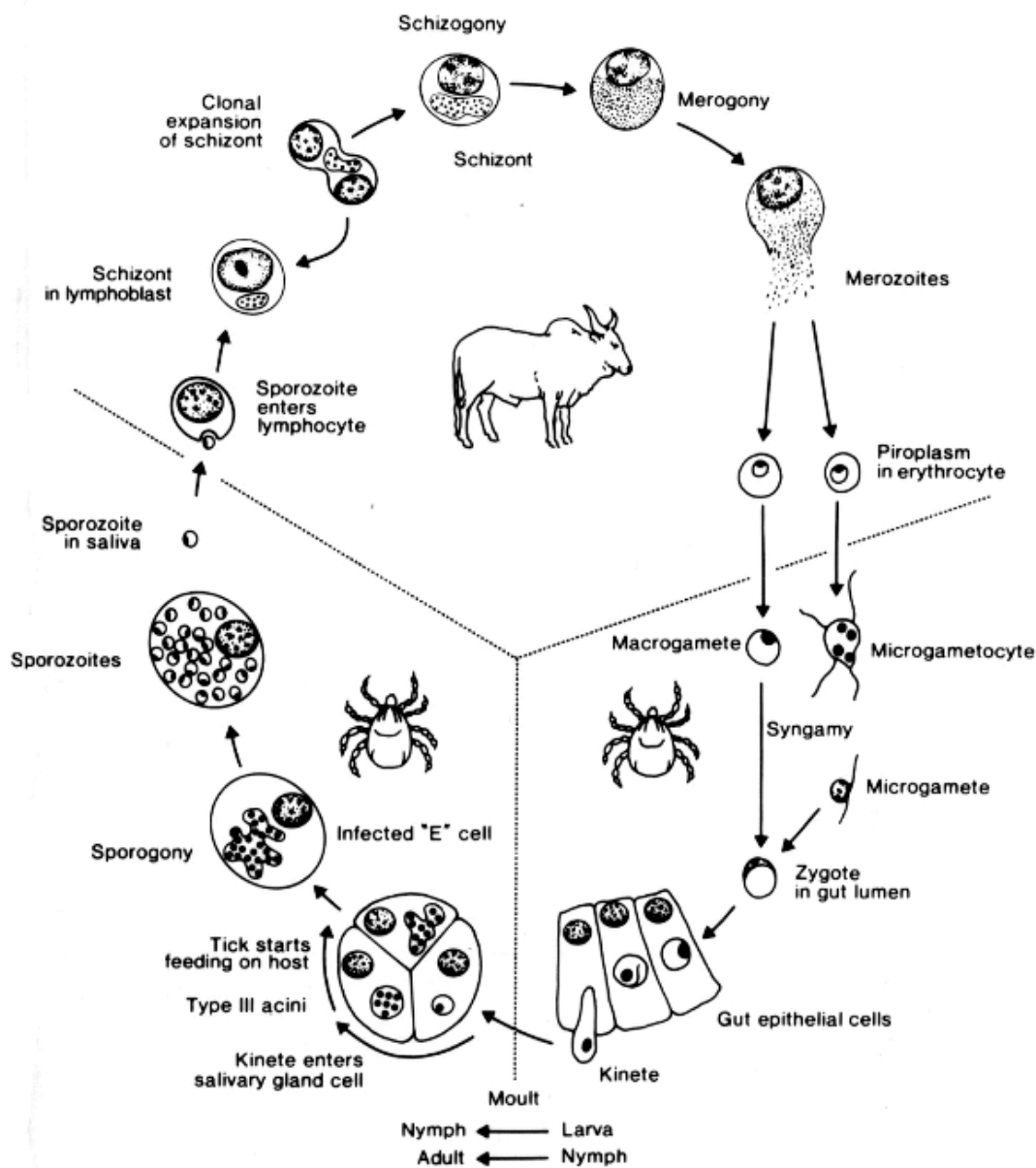

Figure 1.1: Life cycle of *Theileria parva* in cattle and the ixodid tick *Rhipicephalus appendiculatus* (from Norval *et al.*, 1992)

*Theileria parva* has a complex cycle, which includes an asexual cycle in the mammalian host (Shaw *et al.*, 1991) and a sexual cycle in the invertebrate host (tick) (Watt and Walker, 2000) (fig. 1.1). In the mammalian host *T. parva* parasitizes white

blood cells (WBC) and red blood cells (RBC) in succession to complete its life cycle. Sporozoites, which are the infective stage to the mammalian host, are injected during the feeding of infected ticks and enter lymphocytes to develop into schizonts. The schizont-infected WBC population expands exponentially synchronously with the divisions of the schizont itself (schizogony) (Stagg *et al.*, 1980) and is disseminated through the entire lymphoid system. Within 12-14 days post infection a proportion of schizonts differentiate into merozoites (merogony) that are later liberated from lymphocytes. Merozoites are infective to RBC wherein they give rise to piroplasms. During feeding on an infected animal, ticks ingest infected RBCs. Piroplasms infected RBCs are lysed in the tick gut releasing piroplasms in the gut. These free piroplasms undergo a complex cycle in the gut lumen of the tick which includes a sexual cycle that results in the formation of motile kinetes. These kinetes have a predilection for e-cells of type III acini one of the four types of acinus of the tick salivary glands and develop into sporoblasts (Fawcett *et al.*, 1982). Type three acini are responsible for fluid transport as the tick concentrates blood meals (Bowman and Sauer, 2004). The cycle is only completed after the tick moults and starts feeding on a new host in its next instar. During feeding the parasites undergo a second multiplication phase (sporogony) resulting in sporozoites that are liberated into the saliva. The sporozoites are injected into the host and enter the lymphocytes completing the cycle.

*Theileria parva* is the most important *Theileria* species infecting cattle in southern Africa. Other *Theileria* species affecting cattle include *Theileria annulata*, *T. mutans*, *T. sergenti*, *T. orientalis*, *T. buffeli*, *T. taurotragi* and *T. velifera*. *Theileria annulata* parasitizes cattle and Asiatic buffalo (*Bubalus bubalis*). It is important in northern Africa where it causes tropical theileriosis. *Theileria mutans* has been known to sometimes cause severe and fatal disease in cattle in east Africa but is largely non pathogenic to cattle in southern Africa. *Theileria orientalis*, *T. buffeli* and *T. sergenti* are parasites of low pathogenicity considered to be one species, though not confirmed as such (Norval *et al.*, 1992). That one species was earlier thought to be *T. mutans*. *Theileria orientalis* in Africa has been reported in Ethiopia and Burundi (Norval *et al.*, 1992). *Theileria taurotragi* and *T. velifera* are non pathogenic in cattle, however, their importance is in the confusion their presence creates with diagnosis due to morphological similarity with *T. parva*. In addition *T. parva* and *T. taurotragi*, (including *T. annulata* and *T. mutans*) antigens produce cross reactions on the most

widely used routine serological test, the indirect fluorescent antibody test (IFAT). Further, mixed infection of *T. parva* and *T. taurotragi* in ticks results in high infection rates of *T. parva* (Young *et al.*, 1980).

### **1.3 The disease (East Coast fever)**

#### **1.3.1 The mammalian host**

The development of *T. parva* that involves parasitizing bovine leucocytes and erythrocytes in succession is what causes ECF in cattle. The disease is characterised by swelling of lymph nodes beginning with the parotid lymph node closest to the ear or eyelid surface which are the predilection feeding sites of the vector ticks. Later the lymphadenopathy is generalised. Other clinical features of ECF include; a fever (39.5-42°C), severe dyspnoea and frothing at the nostrils due to interstitial pneumonia and pulmonary oedema and, high mortalities. Animals that recover naturally or after treatment with theilericides have long lasting immunity giving complete protection to homologous challenge (Burridge *et al.*, 1972), but may be susceptible to some heterologous strains. Recovered or immunised animals remain carriers of the infection for life and therefore serve as a source of infection to ticks.

#### **1.3.2 The distribution of ECF**

The distribution of ECF follows that of the principal vectors of *T. parva* (fig. 1.2). However, ECF does not occur throughout the range of the vector ticks' distribution (Norval *et al.*, 1992b). This is because the distribution of the vector ticks even in the countries where they are known to occur commonly is not continuous being influenced mainly by climate, vegetation and host availability. Further, high temperatures (>33°C) experienced in some ecologically marginal areas within the range of the ticks' distribution do not allow development of theileria in the vector ticks (Young and Leitch, 1981). Further still in areas of extreme climatic conditions ECF may fail to establish itself due to low tick numbers for long periods (Speybroeck *et al.*, 2002). Contrary to this general observation Bazarusanga *et al.* (2007) reported a not yet fully explained phenomenon in Rwanda, of higher *T. parva* prevalence in cattle in a region with lower tick numbers compared to two regions with higher tick numbers.

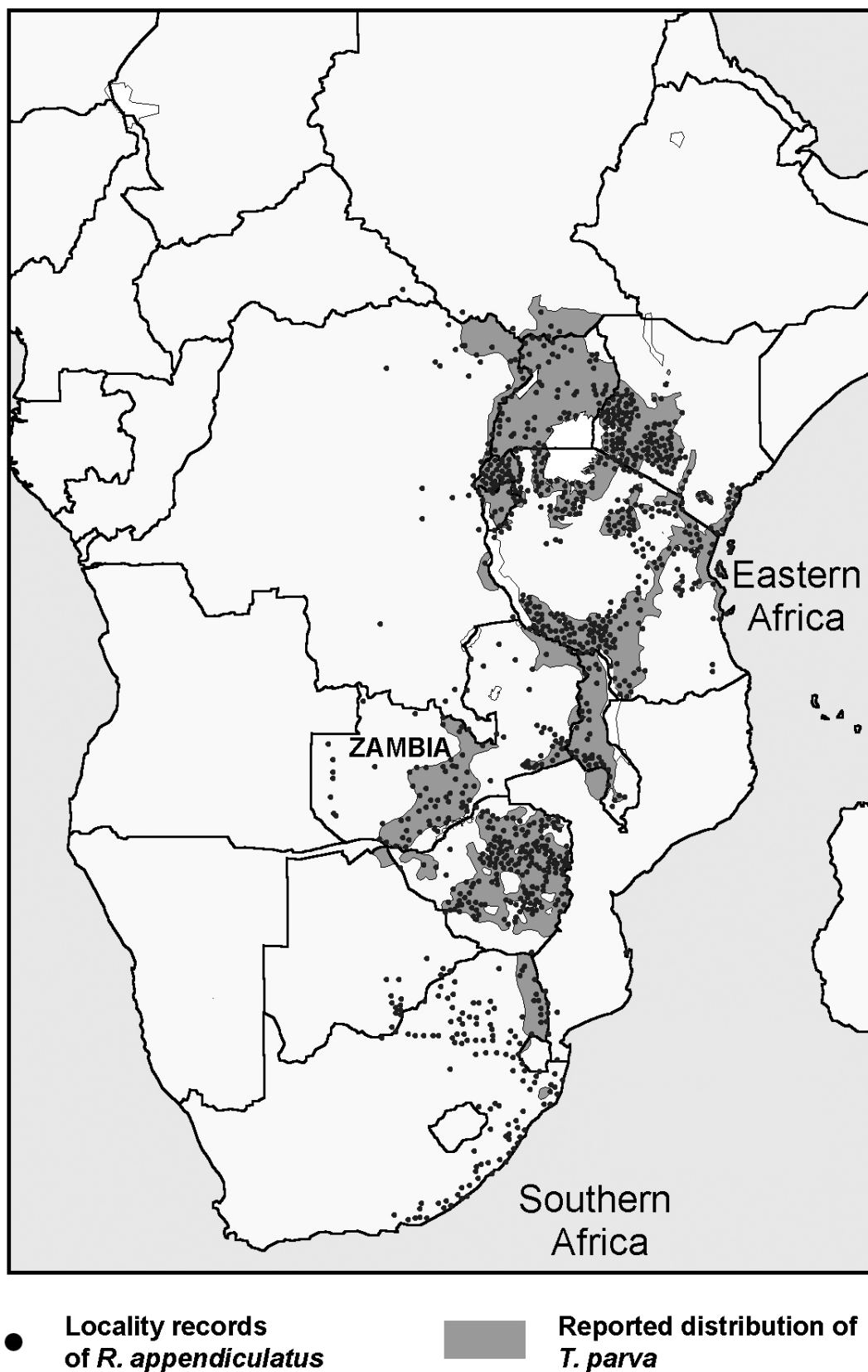

Figure 1.2: Distribution range of *Theileria parva* and *Rhipicephalus appendiculatus* (from Chaka, 2001)

### 1.3.3 The epidemiology of ECF

The epidemiology of ECF varies between eastern, central and southern Africa. The variables of ECF epidemiology can broadly be divided into host, parasite and tick vector factors. The vector factors include; seasonality, abundance and the level of infection in the tick population (Norval *et al.*, 1991). The level of infection in a tick population is influenced by ambient temperature, the behaviour of the *T. parva* (may be low or high piroplasm producing), the susceptibility of *R. appendiculatus* strains to *T. parva* infections, the presence of infected hosts and whether the infected hosts are clinical cases or carriers (Young, 1981). Carrier animals are those that have recovered from the primary infection but maintain piroplasms circulating in the blood at levels that are enough to infect ticks but not always detectable by routine diagnostic techniques (Medley *et al.*, 1992). Ticks acquire higher infections when they feed on clinical cases than carrier cases. The latter present extremely low parasitaemias (piroplams) hindering the development of high infections in ticks (Young *et al.*, 1996). Carriers might include the African buffalo which is the wildlife reservoir of infection (Burrige, 1975). Total level of infection in a population of ticks also depends on the numbers (abundance) of feeding stages on such clinical and or carrier hosts. The abundance of feeding stages in an area is in turn influenced by host availability and macro- and micro-climatic requirements of the vector (Yeoman, 1967; Norval and Lightfoot, 1982; Mulumba *et al.*, 2000; Fandamu *et al.*, 2005). The microclimate is modulated by vegetation cover (Minshull and Norval, 1982). Climatic conditions vary throughout the range of *R. appendiculatus* and *R. zambeziensis*. In response the ticks have evolved different behavioural and survival strategies. One such behavioural strategy is the diapause phenomenon exhibited by ticks from regions with a marked wet and dry season that enables ticks to delay feeding and hence oviposition so that the most vulnerable stages of their life cycles are synchronised with the incidence of favourable climatic conditions. Within the diapause phenomenon ticks from different geographic areas have evolved different strategies for the initiation and termination of diapause (Berkvens *et al.*, 1995; Madder *et al.*, 2002). These behavioural strategies affect not only their abundance but also the number of generations per year. The number of generations per year, among other factors, has an effect on the establishment of endemic stability (Perry *et al.*, 1992; Billiouw *et al.*, 1999; Billiouw *et al.*, 2002; Marcotty *et al.*, 2002), which is the epidemiological state of a population in which clinical disease is scarce despite high

level of infection (Coleman *et al.*, 2001). A *T. parva* specific definition of endemic stability is the epidemiological state in which, all calves born become infected before the age of 6 months and clinical disease is rare (Moll *et al.*, 1986). Billiouw (2005) has recently suggested three different levels of endemic stability i.e. first level, second level and ultimate endemic stability based on three main parameters. These parameters are, increased *T. parva* challenge, decreasing case fatality rate and a self-generating carrier state.

#### **1.3.4 The control of ECF**

East Coast fever can be controlled using a number of measures singly or in combination. These measures may be divided into three i.e. *T. parva* parasite control (chemotherapy), immunization of susceptible hosts and tick vector control. *Theileria parva* parasite control aims at managing the parasite in the mammalian host which mostly takes the form of treatment of clinical cases. Three effective theilericidal compounds are available for this, i.e. halofuginone, parvaquone and buparvaquone (Dolan, 1981, 1999). For some years now immunisation has been and still is by an infection and treatment procedure (Radley *et al.*, 1975; Marcotty *et al.*, 2001; Mbao *et al.*, 2006). This involves injecting cattle with live sporozoite material with the concomitant application of long-acting tetracyclines. Long acting tetracyclines slow down the division of schizonts and the schizont infected cells against which cellular immune responses are directed. Other vaccines tried include; the 67kD circum-sporozoite antigen protein (p67) recombinant forms of which induce high antibody titres in cattle (Kaba *et al.*, 2004; Musoke *et al.*, 2005) and the Polymorphic Immunodominant molecule (PIM) (Toye *et al.*, 1996). However the p67 only offers partial protection under field conditions. Vector control activities include practices such as movement restrictions which essentially entails keeping clean cattle away from infested pastures or herds, application of acaricides which take the form of plunge dips, sprays, pour-ons or hand-dressing preparations like “tick grease” and selection of tick resistant cattle. Choosing control options from the above in the context of integrated ECF control strategies depends on the production system, the prevalence of other tick-borne diseases and the epidemiological state of ECF for the area in question (Uilenberg, 1996; Billiouw, 2005). As already stated, the epidemiological state of an area is influenced by among other variables the vector factors. The vector factors of seasonality, abundance, vectorial competence and



capacity are modulated by the environment and factors inherent to the vector itself. Factors inherent to the vector itself may be genetic, phenotypic or a combination of both. Therefore an understanding of both genetic and phenotypic variation in the vector ticks infesting livestock in an area would contribute to the understanding of the ECF epidemiology of that area and subsequently aid in the choice and design of control strategies.

## **1.4 The vectors**

### **1.4.1 Systematic relationship of *R. appendiculatus* and *R. zambeziensis* to other ticks**

Hoogstraal (1956) has classified ticks as invertebrates belonging to the Phylum Arthropoda, the joint-legged animals and the subphylum Chelicerata. Chelicerates are characterized by two bladed chelicerae, essentially modified first appendages used for grasping, piercing, cutting and other functions associated with food gathering and feeding (fig. 1.3). Another distinguishing characteristic of the chelicerates is the division of the body into only two major regions namely the prosoma and the opisthosoma. They are members of the class Arachnida whose adults are eight-legged.

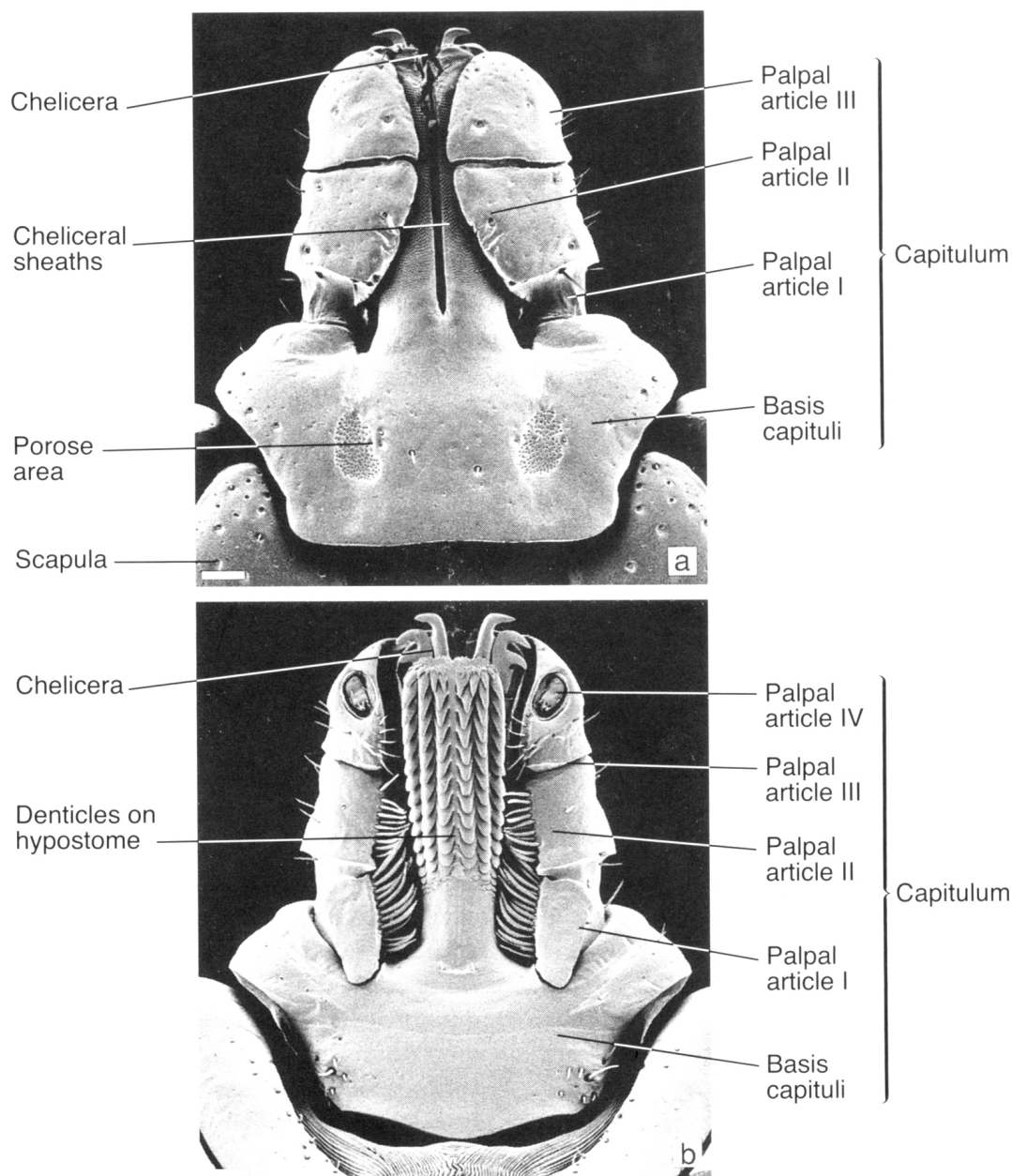
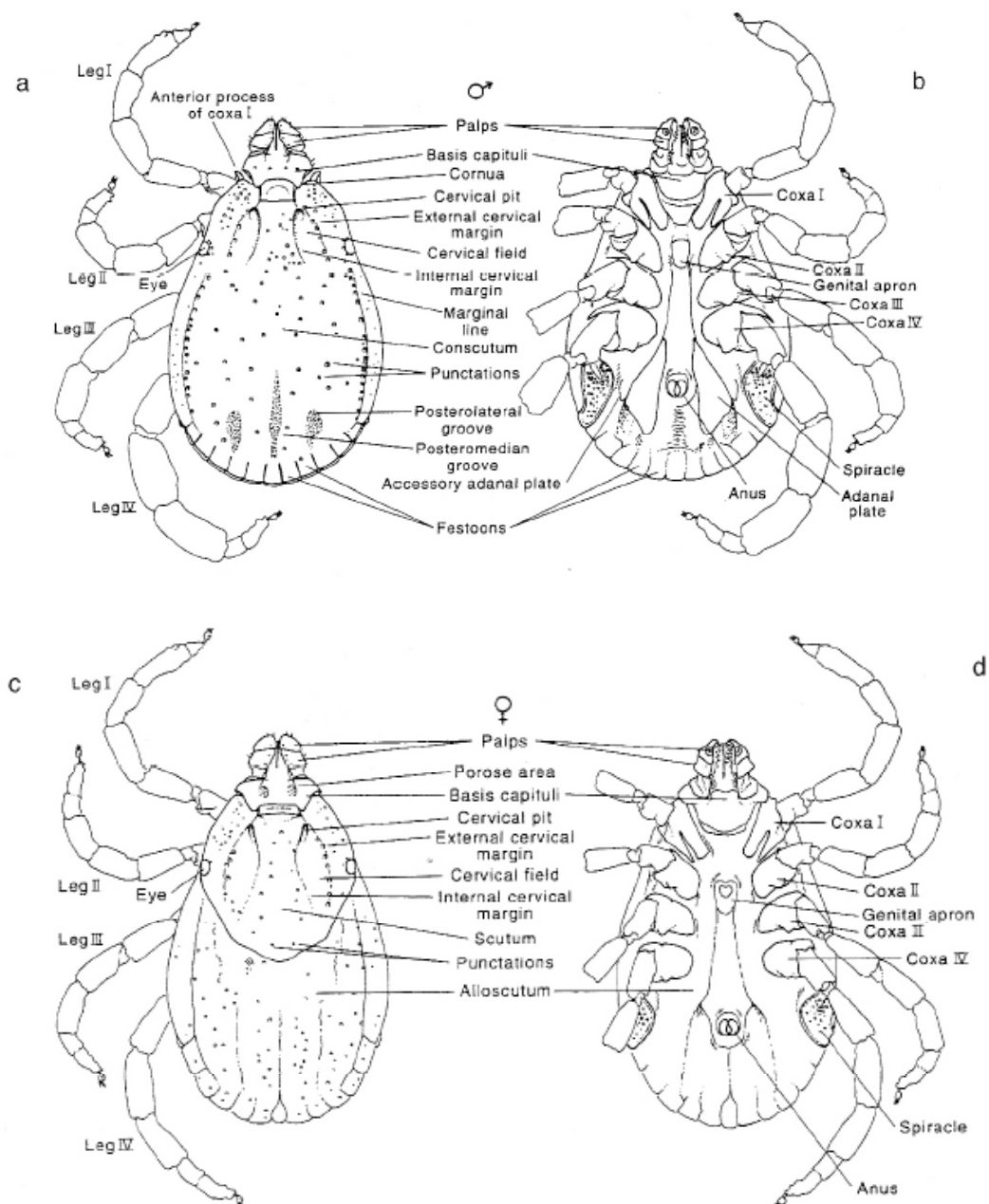

**Figure 1.3: SEM of the dorsal and ventral aspects of capitulum showing chelicerae a characteristic of members of the Subphylum Chelicerata (Walker *et al.*, 2000)**

Ticks are included in the order Acari, a large and diverse group to which ticks and mites belong. Within the Acari, ticks are confined to the Suborder Ixodida (=Metastigmata) whose members are obligate blood-sucking parasites. The suborder Ixodida encompasses three families, the Argasidae, Nuttalliellidae and Ixodidae. *Rhipicephalus appendiculatus* and *R. zambeziensis* are placed in the family Ixodidae

whose members are characterised by having a hard sclerotized (con) scutum and the subfamily Rhipicephalinae (Keirans, 1992).

### 1.4.2 The Genus *Rhipicephalus*



**Figure 1.4: Adults of *Rhipicephalus* spp. showing morphological features. Male: (a) dorsal view; (b) ventral view. Female: (c) dorsal view; (d) ventral view (Walker *et al.*, 2000)**

*Rhipicephalus* is one of the largest genera of the family Ixodidae with 74 reported species (Walker *et al.*, 2000). If the synonymy of *Boophilus* Curtrice, 1891 with *Rhipicephalus* Koch, 1844 suggested by Murrell and Barker (2003) based on the

evidence from studies by Murrell *et al.* (2000) and Beati and Keirans (2001) is accepted the number of species in this genus would be 79.

Species in this genus have the following morphological features (fig. 1.4): their hypostome and palps are short and their basis capituli is usually hexagonal; they have eyes, festoons and; in the males, adanal plates. Except for *Rhipicephalus dux*, *Rhipicephalus humeralis*, *Rhipicephalus maculatus* and *Rhipicephalus pulchellus* all the known species in this genus do not have a colour pattern on the scutum, hence their common name ‘the brown ticks’. Majority of species in this genus (approximately 54) are found in Africa. However, one species, *Rhipicephalus sanguineus* (a species well adapted to living in homes and dog kennels) is found world-wide between 50° north and 30° south of the equator (Walker *et al.*, 2000).

### **1.4.3 General life cycle of *R. appendiculatus* and *R. zambeziensis***

The life cycle of *R. appendiculatus* and *R. zambeziensis* consists of four stages (fig. 1.5): eggs, larvae, nymphs and adults. Larvae, nymphs and adults each go through a parasitic and free-living phase by a pattern of host seeking, feeding and off-the-host moulting. This developmental pattern is a typical three-host cycle where each unfed life stage (larvae, nymphs or adults) feeds on a separate host. After moulting, followed by a period of hardening and in certain instances dormancy (quiescence or diapause), immatures and adults alike seek hosts, a process called questing (Sonenshine, 1993). This involves leaving their niches at the soil vegetation interface to vegetation tips to acquire hosts by direct contact. Variations in seasonal ambient conditions have an influence on the questing activity (Punyua and Newson, 1979; Punyua *et al.*, 1984; Pegram *et al.*, 1986; Short and Norval., 1981; Speybroeck *et al.*, 2003).

Successful attachment on a suitable host at the predilection site is followed by feeding. Feeding periods vary depending on the host and ambient temperatures (Branagan, 1974). On cattle, feeding may take 6 days for larvae and 8 days for nymphs and adults. These periods may be longer depending on host resistance and environmental conditions like temperature. After feeding for at least 4 days adult males and females mate on the host. Complete engorgement of females follows after mating. Fed females detach and seek a suitable microenvironment. Oviposition commences after a 3-10 day period of preovipositional development. Females lay a

large number of eggs ( $\pm 4000$  eggs). Period of oviposition may last up to a month depending on ambient temperatures. Males may remain on the host for 4-6 weeks and mate with successive batches of females (Branagan, 1974).

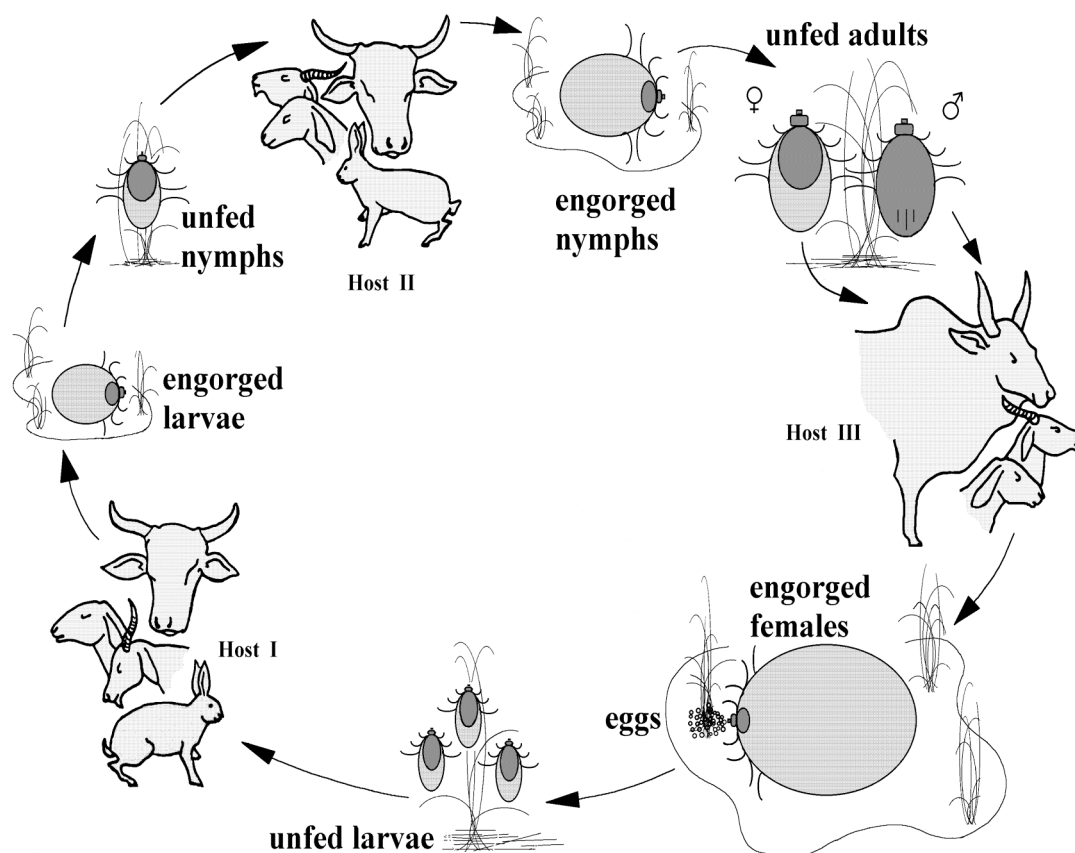

**Figure 1.5: Life cycle of three host tick *Rhipicephalus appendiculatus* (from Speybroeck, 2003)**

Larvae fed to repletion drop from their host and find a sheltered microenvironment and undergo moulting and metamorphosis. Nymphs will emerge. Nymphs that dropped from their host undergo metamorphosis and moult into adults. Minshull and Norval (1982) studied drop-off rhythms of larvae, nymphs and females of *R. appendiculatus* on cattle under natural conditions of light and temperature in Zimbabwe. Most engorged larvae dropped off between 10:00 and 14:00 hours, nymphs between 12:00 and 18:00 hours. Both periods are associated with increased activity of the host (cattle) that normally would be at pasture during these periods. Majority of engorged adults dropped off between 06:00 and 08:00 hours when cattle are in their night paddocks or enclosure and therefore less active. A related study in Kabete, Kenya by Mwangi *et al.* (1991) reported similar observations but did not observe any pattern in larvae drop offs. The different stages seem to have

synchronised their drop off times with host behaviour patterns so that they are deposited in optimal habitats for their development and offer the next instar greater chance to encounter a suitable host (Sonenshine, 1993).

### 1.5 *Rhipicephalus appendiculatus* and *R. zambeziensis* in Zambia

Zambia is a landlocked country in the southern African region (fig. 1.6). It lies between (8°30'-18'S -22°-33°30' E).

The country is divided into nine administrative provinces; Northern, Luapula, Copperbelt, North-western, Western, Central, Lusaka, Eastern and Southern provinces. The Western, Eastern and Southern provinces are the most important traditional cattle rearing areas.

Zambia is composed of a series of plateaus ranging from 900-1500m. The highest plateau, which reaches a maximum altitude of 2000m, is in the east and north-east of the country. The major depressions are the valleys of the Luangwa and Zambezi rivers. Other (minor) depressions are found around lakes Mweru, Mweru Wantipa and Tanganyika.

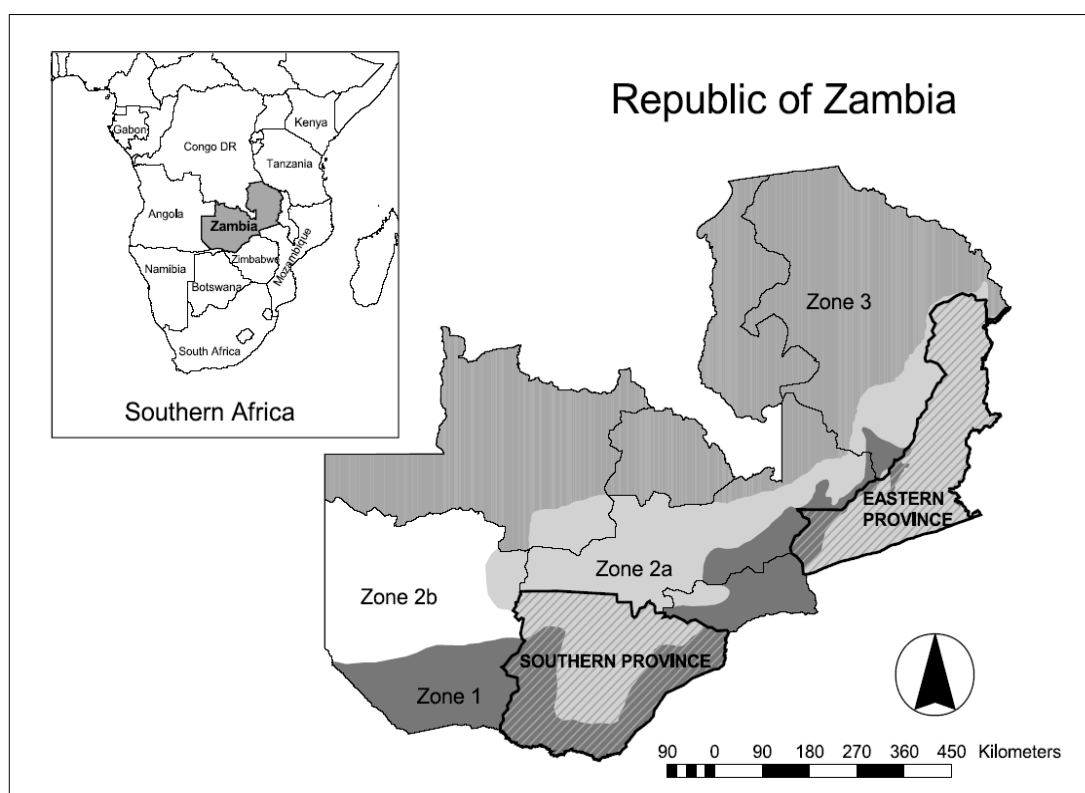

**Figure 1.6: Map of Zambia Eastern and Southern provinces and the ecological Zones 1, 2a, 2b and 3. See text for explanation of the Zones. Insert Map of Southern Africa showing the position of Zambia**

The climate of Zambia is tropical and is influenced by altitude. There are three climatic seasons (Philip's, 2004a): (a) A hot and wet season – starts from mid October to November and lasts up to March or April. This characterised by wet and warm conditions. Annual rainfall averages 1400 millimetres in the northern part of the country and decreases in the south to 600 millimetres. Mean relative humidity averages over 75%. (b) A cool dry season – from April to mid August with mean temperatures in June/July of 5 - 10°C in the Central, Southern and Western Zambia and 10 – 13°C in the Eastern and North-eastern Zambia. (c) A hot and dry season- starts mid August and ends about mid October to early November. Temperatures are high with the highest mean maximum temperatures recorded in the valleys (Luangwa and Zambezi) where they may exceed 35°C.

### **1.5.1 The vegetation of Zambia**

Zambia's "original" or natural vegetation consists of savannahs, woodland, grassland and small amounts of forests and swampland (Philip's, 2004b). However, a large proportion of the original Zambian vegetation has been cleared for agriculture and other human activities. The resultant vegetation can be divided into Savannah woodlands and Grasslands. The woodlands can be divided into three types; Miombo, Munga and Mopane woodlands. The Miombo woodland is characterised by the presence of *Brachystegia*, *Julbernadia* and *Isoberlinia* species and is found on poorer soils with sparse grass cover. Munga Woodland is dominated by *Acacia*, *Combretum* and *Terminalia* species that grow among tall grass on better soils. Mopane Woodland (*Colophospermum mopane*) is found in the hot drier valleys of the Luangwa and Zambezi rivers.

### **1.5.2 Agro-ecological zones of Zambia**

Based on the vegetation, climate and physical characteristics the country is divided into three agro-ecological regions (Fig. 1.6). Zone 1 is characterised by low rainfall (maximum 600mm per year), is drought prone with high minimum temperatures and erodible soils.

Zone 2 is found in Eastern, central and southern provinces of Zambia. This region receives 800 to 1000mm of rain. The region has moderately leached clayey to loamy soil (2a), slightly leached clayey soils and sandy soils on Kalahari sands (2b). Zone 3

covers the northern and north-western parts of Zambia. This is a high rainfall region with annual rainfall of over 1000mm. The soils are highly leached.

The ecology, distribution and phenology of ticks including *R. appendiculatus* and *R. zambeziensis* has been well described in Zambia (MacLeod, 1970; MacLeod and Colbo, 1976; MacLeod *et al.*, 1977; MacLeod and Mwanaumo, 1978; Pegram *et al.*, 1986; Pegram and Banda, 1990; Berkvens *et al.*, 1998; Zieger *et al.*, 1998; Chaka *et al.*, 1999; Speybroeck *et al.*, 2002). Generally *R. appendiculatus* and *R. zambeziensis* distribution is affected by altitude and climatic factors especially the rain patterns. Briefly *R. appendiculatus* is found throughout the country while *R. zambeziensis* may be restricted to the hotter low lying areas. In Zambia the ranges of the two taxa overlap in some areas (Speybroeck *et al.*, 2002). The distribution of ECF in Zambia generally follows the distribution of its main field vectors. However, not all the places in the country where the vectors are found experience ECF. For instance *R. appendiculatus* is present in western province but the area is free of clinical cases of ECF (Akafekwa, 1976) due to the transhumance that is practised in this area. During the peak of adult activity the animals are kept in the flood plains. The flood plains are not suitable for laying and subsequent eclosion of the eggs. During the peak of nymphal activity cattle are kept on the drier highlands. The rest of the provinces have recorded clinical cases of the disease. The Northern province was the first to get a confirmed case of the ECF in 1922 at Nakonde, a north-eastern town on the border with Tanzania (Nambota *et al.*, 1994). The disease was later reported in the Eastern province towards mid last century. The epidemiology of the disease in Eastern province has been described as first level endemically stable state (Billiouw, 2005). Billiouw (2005) described this state as a situation where all adult cattle are immune and the infection prevalence in the cattle population is stable, its level depending mainly on the level of *T. parva* challenge and on the calving rate with case fatality reduced to about 50%. This epidemiological picture is different from that obtaining in Southern province which has been described as epidemic. This is an epidemiological state in which both adult cattle and calves are susceptible and actually get infected (Billiouw, 2005).

The difference in the epidemiological states between the two provinces might be attributed to a number of factors some of which are: the more recent introduction of the disease in Southern province (1978) (Nambota *et al.*, 1994), the difference in



virulence of the main circulating *T. parva* strains in the two provinces (Geysen *et al.*, 1999) and the difference in the ecology of the stocks of *R. appendiculatus* infesting cattle in the two provinces. Of these factors, the difference in vector ecology may be the most important (Norval *et al.*, 1991; Billiouw *et al.*, 1999). Speybroeck *et al.* (2002) and Billiouw *et al.* (1999) have attributed the attainment of the state of first level endemic stability in Eastern province to the existence of a second wave of adults of *R. appendiculatus* which ensures a more continuous *T. parva* challenge in a year leading to a higher number of “exposed” animals in the herds. In Southern province, the unimodal phenology of adult *R. appendiculatus* coupled with the mixed presence of *R. appendiculatus* and *R. zambeziensis* has been implicated in the current epidemic state. This mixed presence of *R. appendiculatus/ zambeziensis* has been associated with the cool dry season ECF cases in periods of below average rainfall. It is therefore apparent that variation in vector ecology has profound influence on the epidemiology of ECF and therefore demands investigation.

## 1.6 References

- Adl, S.M., A.G.B. Simpson, M.A. Farmer, R.A. Andersen, O.R. Anderson, J.R. Barta, S.S. Bowser, G. Brugerolle, R.A. Fensome, S. Fredericq, T.Y. James, S. Karpov, P. Kugrens, J. Krug, C.E. Lane, L.A. Lewis, J. Lodge, D.H. Lynn, D.G. Mann, R.M. McCourt, L. Mendoza, Ø. Moestrup, S.E. Mozley-Standridge, T.A. Nerad, C.A. Shearer, A.V. Smirnov, F.W. Spiegel and M.F.J.R. Taylor. 2005. The new higher level classification of eukaryotes with emphasis on the taxonomy of protists. *Journal of Eukaryote Microbiology*, 52, 399-451.
- Akafekwa, G. 1976. Control of tick-borne diseases in Zambia with special emphasis on East Coast fever. *Bulletin de l'Office International des Epizooties*, 86, 105-116.
- Bazarusanga, T., J. Vercruyse, T. Marcotty and D. Geysen. 2007. Epidemiological studies on Theileriosis and the dynamics of *Theileria parva* infections in Rwanda. *Veterinary Parasitology*, 143, 214-221.
- Beati, L. and J.E. Keirans. 2001. Analysis of the systematic relationships of among ticks of the genera *Rhipicephalus* and *Boophilus* (Acari: Ixodidae) based on mitochondrial 12S ribosomal DNA gene sequences and morphological characteristics. *Journal of Parasitology*, 87, 32-48.
- Berkvens, D.L., R.G. Pegram and J. Brandt. 1995. A study of the diapausing behavior of *Rhipicephalus appendiculatus* and *Rhipicephalus zambeziensis* under quasi-natural conditions in Zambia. *Medical and Veterinary Entomology*, 9, 307-315.
- Berkvens, D.L., D.M. Geysen, G. Chaka, M. Madder and J.R.A. Brandt. 1998. A study of ixodid ticks parasitizing cattle in the Eastern Province of Zambia. *Medical and Veterinary Entomology*, 12, 234-240.
- Billiow, M., L. Mataa, T. Marcotty, G. Chaka, J. Brandt and D. Berkvens. 1999. The current epidemiological status of bovine theileriosis in eastern Zambia. *Tropical Medicine and International Health*, 4, pp A28-A33.
- Billiow, M., J. Vercruyse, T. Marcotty, N. Speybroeck, G. Chaka and D. Berkvens. 2002. *Theileria parva* epidemics: a case study in eastern Zambia. *Parasitology*, 107, 51-56.
- Billiow, M. 2005. Chapter 6 (pp115-129). General Discussion. The epidemiology of bovine theileriosis in the eastern province of Zambia. PhD thesis, pp 139. Ghent University, Ghent.
- Bishop, R., A. Musoke, S. Morzaria, M. Gardner and V. Nene. 2004. *Theileria*: intracellular protozoan parasites of wild and domestic ruminants transmitted by ixodid ticks. *Parasitology*, 129, S271-S283.
- Bowman, A.S. and J.R. Sauer .2004. Tick salivary glands: function, physiology and future. *Parasitology*, 129, S67-S81.
- Branagan, D. 1974. The feeding performance of the ixodid *Rhipicephalus appendiculatus* Neumann on rabbits, cattle and other hosts. *Bulletin of Entomological Research*, 64, 387-400.

- Burridge, M.J., C.G.D. Brown, M.P. Cunningham and S.P. Morzaria. 1972. Duration of immunity to East Coast fever (*Theileria parva* infection of cattle). *Parasitology*, 64, 511-515.
- Burridge, M.J. 1975. The role of wild mammals in the epidemiology of bovine theileriosis in East Africa. *Journal of Wildlife Diseases*, 11, 68-75.
- Chaka, G., M. Billiouw, D.M. Geysen and D.L. Berkvens. 1999. Spatial and temporal variation in *Rhipicephalus appendiculatus* size in eastern Zambia. *Tropical Medicine and International Health*, 4, A43-A48.
- Chaka, G. 2001. Eco-physiology of *R. appendiculatus* (Acari: Ixodidae) in eastern Zambia. PhD thesis. ITMA, Antwerpen
- Coleman, P.G., B.D. Perry and M.E.J. Woolhouse. 2001. Endemic stability- a veterinary idea applied to human public health. *Lancet*, 357, 1284-1286.
- Dolan, T. T. 1981. (pp 186-208). Progress in the Chemotherapy of Theileriosis. *In: Irvin, A., M. P. Cunningham and A. S. Young (Eds.). Advances in the Control of Theileriosis.* Martinus Nijhoff Publishers, The Hague.
- Dolan, T. T. 1999. Dogmas and misunderstandings in East Coast fever. *Tropical Medicine and International Health* 4, A3-A11.
- Fandamu, P., L. Duchateau, N. Speybroeck, T. Marcotty, V. Mbao, J. Mtambo, M. Mulumba and D. Berkvens. 2005. *Theileria parva* sero-prevalence in traditionally kept cattle in southern Zambia and El Niño. *International Journal for Parasitology*, 35, 391-396.
- Fawcett, D.W., G. Büscher and S. Doxsey. 1982. Salivary gland of the tick vector of East Coast fever III. The ultrastructure of sporogony in *Theileria parva*. *Tissue and Cell*, 14, 183-206.
- Geysen, D., R. Bishop, R. Skilton, T.T. Dolan and S. Morzaria. 1999. Molecular epidemiology of *Theileria parva* in the field. *Tropical Medicine and International Health*, 4, A21-A27.
- Hoogstraal, H. 1956. African Ixodidae I. Ticks of the Sudan (with special reference to equatorial province and with preliminary reviews of the genera *Boophilus*, *Margaropus* and *Hyalomma*). U.S. Naval Medical research Unit No. 3, Cairo.
- Kaba, S.A., C. Schaap, E.C. Roode, V. Nene, A.J. Musoke, J.M. Vlak and M.M. van Oers. 2004. Improved immunogenicity of novel baculovirus-derived *Theileria parva* p67 subunit antigens. *Veterinary Parasitology*, 121, 53-64.
- Keirans, J.E. 1992. Chapter 1 (pp1-21). Systematics of the Ixodida (Argasidae, Ixodidae, Nuttalliellidae): An overview and some problems. *In: Fivaz, B., T. Petney and I Horak. (Eds.) Tick Vector Biology; Medical and Veterinary aspects.*
- Kivaria, F.M. 2006. Estimated direct economic costs associated with tick-borne diseases on cattle in Tanzania. *Tropical Animal Health and Production*, 38, 291-299.
- Kivaria, F. M., M.R. Ruheta, P.A. Mkonyi and P.C. Malamsha. 2007. Epidemiological aspects and economic impact of bovine theileriosis (East Coast fever) and its control: a preliminary assessment with special reference to Kibaha district, Tanzania. *The Veterinary Journal*, 384-390.

- Klompen, J.S.H., W.C. Black IV, J.E. Keirans and J.H. Oliver Jr. 1996. Evolution of Ticks: Annual Review Entomology, 41, 141-161.
- Lawrence, J.A., R.A.I. Norval and G. Uilenberg. 1983. *Rhipicephalus zambeziensis* as a vector of bovine theileriae. Tropical Animal Health and Production, 15, 39-42.
- Lessard, P., R. L'Eplattenier, R. A. I. Norval, K. Kundert, T. T. Dolan, H. Croze, J. B. Walker, A. D. Irvin and B. D. Perry. 1990. Geographical information systems for studying the epidemiology of cattle diseases caused by *Theileria parva*. Veterinary Record, 126, 255-262.
- Levine, N.D., J.O. Corliss, F.E.G. Cox, G. Deroux, J. Grain, B.N. Honigberg, G.L. Leedale, A.R. Loeblich II, J. Lom, D.H. Lynn, F.G. Merinfeld, F.C. Page, G. Poljansky, V. Sprangue, J. Vaura and F.G. Wallace. 1980. A newly revised classification of the Protozoa. Journal of Protozoology, 27, 37-58.
- Lounsbury, C.P. 1904. Transmission of African Coast fever. Agricultural Journal of the Cape of Good Hope, 24, 428-432.
- MacLeod, J. 1970. Tick infestation in the southern province of Zambia. Bulletin of Entomological Research, 60, 253-274.
- MacLeod, J. and M.H. Colbo. 1976. Ecological studies of ixodid ticks (Acari, Ixodidae) in Zambia I. Cattle as hosts of larvae of *Amblyomma variegatum* (F.) and *Rhipicephalus appendiculatus* Neumann. Bulletin of Entomological Research, 66, 65-74.
- MacLeod, J., M.H. Colbo, M.H. Madbouly and B. Mwanaumo. 1977. Ecological studies of ixodid ticks (Acari, Ixodidae) in Zambia III. Seasonal activity and attachment sites on cattle with notes on other hosts. Bulletin of Entomological Research, 67, 161-173.
- MacLeod, J. and B. Mwanaumo. 1978. Ecological studies of ixodid ticks (Acari, Ixodidae) in Zambia IV. Some anomalous infestations in the northern and eastern regions. Bulletin of Entomological Research, 68, 409-429.
- Madder, M., N. Speybroeck, J. Brandt, L. Tirry, I. Hodek and D. Berkvens. 2002. Geographic variation in diapause response of adult *Rhipicephalus appendiculatus* ticks. Experimental and Applied Acarology, 27, 209-221.
- Marcotty, T., M. Billiouw, G. Chaka, D. Berkvens, B. Losson and J. Brandt. 2001. Immunisation against East Coast fever by the infection and treatment method: evaluation of the use of ice baths for the field delivery and appraisal of an acid formulation of long-acting tetracycline. Veterinary Parasitology, 99, 175-187.
- Marcotty, T., J. Brandt, M. Billiouw, G. Chaka, B. Losson and D. Berkvens. 2002. Immunisation against *Theileria parva* in eastern Zambia: influence of maternal antibodies and demonstration of carrier status. Veterinary Parasitology, 110, 45-56.
- Mbao, V., D. Berkvens, T. Dolan, N. Speybroeck, J. Brandt, P. Dorny, P. Van den Bossche and T. Marcotty. 2006. Infectivity of *Theileria parva* sporozoites following cryopreservation in four suspension media and multiple refreezing: evaluation by *in vitro* titration. Onderstepoort Journal of Veterinary Research, 73, 207-213.

- Medley, G. F., B.D. Perry and A.S. Young. 1992. Preliminary analysis of the transmission dynamics of *Theileria parva* in eastern Africa. *Parasitology*, 106, 251-264.
- Minshull, J.I. and R.A.I. Norval. 1982. Factors influencing the spatial distribution of *Rhipicephalus appendiculatus* in Kyle Recreational Park, Zimbabwe. *South African Journal of Wildlife Research*, 12, 118-123.
- Moll, G., A. Lohding, A.S. Young and B.L. Leitch. 1986. Epidemiology of theileriosis in calves in an endemic area of Kenya. *Veterinary Parasitology*, 19, 255-273.
- Mulumba, M., N. Speybroeck, M. Billiouw, D.L. Berkvens, D.M. Geysen and J. R. A. Brandt. 2000. Transmission of theileriosis in the traditional farming sector in the Southern Province of Zambia during 1995–1996. *Tropical Animal Health and Production* 32, 303-314.
- Murrell, A., N.J.H. Campbell and S.C. Barker. 2000. Phylogenetic analyses of the rhipicephaline ticks indicate that the genus *Rhipicephalus* is paraphyletic. *Molecular Phylogenetics and Evolution*, 16, 1-7.
- Murrell, A. and S.C. Barker. 2003. Synonymy of *Boophilus* Curtice, 1891 with *Rhipicephalus* Koch, 1844 (Acari: Ixodidae). *Systematic Parasitology*, 56, 169–172,
- Musoke, A., J. Rowlands, V. Nene, J. Nyanjui, J.M. Katende, P.R. Spooner, S.N. Mwaura, D. Odongo, C. Nkonge, S. Mbongo, R. Bishop and S. Morzaria. 2005. Subunit vaccine based on the p67 major surface protein of *Theileria parva* sporozoites reduces severity of infection derived from field tick challenge. *Vaccine*, 23, 3084-3095.
- Mwangi, E.N., R.M. Newson and G.P. Kaaya. 1991. Drop-off patterns for engorged adult females, nymphs and larvae of *Rhipicephalus appendiculatus*. *Insect Science and its Application*, 12, 629-633.
- Nambota, A., K. Samui, C. Sugimoto, T. Katuta and M. Onuma. 1994. Theileriosis in Zambia: etiology, epidemiology, and control measures. *Japanese Journal of Veterinary Research*, 42, 1-18.
- Neitz, W.O. 1955. Corridor disease: A fatal form of bovine theileriosis encountered in Zululand. *Bulletin of Epizootic Diseases of Africa*, 3, 121-123.
- Norval, R.A.I. and C.J. Lightfoot. 1982. Tick problems in wildlife in Zimbabwe. Factors influencing the occurrence and abundance of *Rhipicephalus appendiculatus*. *Zimbabwe Veterinary Journal*, 13, 11-20.
- Norval, R.A.I., J.A. Lawrence, A.S. Young, B.D. Perry, T.T. Dolan and J. Scott. 1991. *Theileria parva*: influence of vector, parasite and host relationships on the epidemiology of theileriosis in Africa. *Parasitology*, 102, 347-356.
- Norval, R.A.I., B.D. Perry and A.S. Young. 1992. Chapter 3 (pp63-98). Origins, classification and nomenclature of theleiria. *In: The epidemiology of theileriosis in Africa*, pp 481. Academic Press, London.
- Norval, R.A.I., B.D. Perry and A.S. Young. 1992a. Chapter 13 (pp379-403). Economic Impact of Theileriosis and its Control in Africa *In: The epidemiology of theileriosis in Africa*, pp 481. Academic Press, London.

- Norval, R.A.I., B.D. Perry and A.S. Young. 1992b. Chapter 4 (pp 99-130). Tick Vectors of Theileriosis. *In: The epidemiology of theileriosis in Africa*, pp 481. Academic Press, London.
- Pegram, R.G., B.D. Perry, F.L. Musisi and B. Mwanaumo. 1986. Ecology and phenology of ticks in Zambia: seasonal dynamics on cattle. *Experimental and Applied Acarology*, 2, 25-45.
- Pegram, R.G. and D.S. Banda. 1990. Ecology and phenology of ticks in Zambia: development and survival of free-living stages. *Experimental and Applied Acarology*, 8, 291-301.
- Perry, B.D., S.L. Deem, G. F. Medley, S.P. Morzaria and A.S. Young. 1992. The ecology of *Theileria parva* infections of cattle and the development of endemic stability. *In: Munderloh, U.G. and T.J. Kurtii, (Eds.), proceedings of the First International Conference on Tick-borne pathogens. Minnesota, USA, 15-18 September 1992.*
- Philip's. 2004a. Zambia: Climate. (pp 12-13). *In: New Basic Education Resource Atlas for Zambia*. pp 97. Insaka Press Publishers Co. Ltd, Lusaka.
- Philip's. 2004b. Zambia: Vegetation. (pp 9). *In: New Basic Education Resource Atlas for Zambia*. pp 97. Insaka Press Publishers Co. Ltd, Lusaka.
- Punyua, D.K. and R.M. Newson. 1979. (pp441-445). Diurnal and activity behaviour of *Rhipicephalus appendiculatus* in the field. *In: Rodriguez, J.G. (Ed.): Recent advances in acarology, Volume 1. Academic Press: New York.*
- Punyua, D.K., R.M. Newson and M.J. Mutinga. 1984. Diurnal and seasonal activity of unfed adult *Rhipicephalus appendiculatus* (Acari: Ixodidae) in relation to some intrinsic and extrinsic factors II: factors affecting vertical distribution of ticks in the habitat. *Insect Science Application*, 5, 245-246.
- Radley, D. E., C.G.D. Brown, M.P. Cunningham, C.D. Kimber, F.L. Musisi, R.C. Payne, R.E. Purnell, S.M. Stagg and A.S. Young. 1975. East Coast fever 3. Chemoprophylactic immunisation of cattle using oxytetracycline and a combination of theilerial strains. *Veterinary Parasitology*, 1, 51-60.
- Shaw, M.K., L.G. Tilney and A.J. Musoke. 1991. The entry of *Theileria parva* sporozoites into bovine lymphocytes - Evidence for MHC Class-I involvement. *Journal of Cell Biology*, 113, 87-101.
- Short, N.J. and R.A.I. Norval. 1981. The seasonal activity of *Rhipicephalus appendiculatus* Neumann, 1901 (Acari: Ixodidae) in the highveld of Zimbabwe. *Journal of Parasitology*, 67, 77-84.
- Sonenshine, D.E. 1991. *The Biology of Ticks. Volume 1.* Oxford University press. New York, pp447.
- Sonenshine, D.E. 1993. (pp3-91). Ecology of non-nidicolous ticks. *In: The Biology of Ticks. Volume II.* Oxford University press. New York.
- Speybroeck, N., M. Madder, P. Van Den Bossche, J. Mtambo, N. Berkvens, G. Chaka, M. Mulumba, J. Brandt, L. Tirry and D. Berkvens. 2002. Distribution and phenology of ixodid ticks in southern Zambia. *Medical and Veterinary Entomology*, 16, 430-441.

- Speybroeck, N. 2003. The ecology of *Rhipicephalus appendiculatus* complex (Acari: Ixodidae). PhD thesis, Ghent University, Belgium.
- Speybroeck, N., M. Madder, J. Brandt, H. Chungu, P. Van Den Bossche, V. Mbao and D. Berkvens. 2003. Questing activity of *Rhipicephalus appendiculatus* (Acari:Ixodidae) nymphs: a random process? *Physiological Entomology*, 28, 356-361.
- Stagg, D.A., D. Chasey, A.S. Young, S.P. Morzaria and T.T. Dolan. 1980. Synchronization of the division of *Theileria* macroschizonts and their mammalian host-cells. *Annals of Tropical Medicine and Parasitology*, 74, 263-265.
- Toye, P.G., J. Nyanjui, B. Goddeeris and A. J. Musoke. 1996. Identification of neutralization and diagnostic epitopes on PIM, the polymorphic immunodominant molecule of *Theileria parva*. *Infection and Immunity*, 64, 1832-1838.
- Uilenberg, G. 1996. Integrated control of tropical animal parasitoses. *Tropical Animal Health and Production*, 28, 257-265.
- Walker, J.B., J.E. Keirans and I.G. Horak. 2000. Section 2 (pp3-4). Relationships of the ticks (Ixodida) and definition of the genus *In: The Genus Rhipicephalus* (Acari:Ixodidae): a guide to the Brown Ticks of the world, pp 643. Cambridge University Press.
- Watt, D.M. and A.R. Walker. 2000. Pathological effects and reduced survival in *Rhipicephalus appendiculatus* ticks infected with *Theileria parva* protozoa. *Parasitology Research*, 86, 207-214.
- Yeoman, G.H. 1967. Field vector studies of epizootic East Coast fever III. Pasture ecology in relation to *Rhipicephalus appendiculatus* infestation rates on cattle. *Bulletin of Epizootic Diseases of Africa*, 15, 89-113.
- Young, A.S. and B.L. Leitch. 1981. Epidemiology of East Coast fever: some effects of temperature on the development of *Theileria parva* in the tick vector *Rhipicephalus appendiculatus*. *Parasitology*, 83, 199-211.
- Young, A.S., J.G. Grootenhuis, B.L. Leitch and E. Schein. 1980. The development of *Theileria*= *Cytauzoon taurotragi* (Martin and Brocklesby 1960) from eland in its vector *Rhipicephalus appendiculatus*. *Parasitology*, 81, 129-144.
- Young, A.S. 1981. (pp. 38-55). The epidemiology of theileriosis in East Africa. *In: Irvin, A. D., M. P. Cunningham and A. S. Young (Eds.). Advances in the Control of Theileriosis. Proceedings of an International Conference held at ILRAD, Nairobi, 9-13 February, 1981. Martinus Nijhoff Publishers, The Hague.*
- Young, A. S., T. T. Dolan, S. P. Morzaria, F. N. Mwakima, R. A. I. Norval, J. Scott, A. Sherriff and G. Gettinby. 1996. Factors influencing infections in *Rhipicephalus appendiculatus* ticks fed on cattle infected with *Theileria parva*. *Parasitology*, 113, 255-266.
- Zieger, U., I.G. Horak and A.E. Caudwell. 1998. Dynamics of free-living ixodid ticks on a game ranch in the Central province, Zambia. *Onderstepoort Journal of Veterinary Research*, 65, 49-59.





**Chapter 2 - A REVIEW OF VARIATION WITHIN AND  
BETWEEN *R. APPENDICULATUS* AND  
*R. ZAMBEZIENSIS***

## 2.1 Introduction

The important economic and social implications of the cattle disease East Coast fever (ECF) in several African countries including Zambia (Mukhebi *et al.*, 1992; Norval *et al.*, 1992a) caused by the haemaprotist *Theileria parva* transmitted by the *Rhipicephalus appendiculatus*/*R. zambeziensis* complex has led to an appreciable body of information on the vectors (MacLeod, 1970; Walker *et al.*, 1981; Lawrence *et al.*, 1983; Perry *et al.*, 1990; Madder *et al.* 1999, 2005; Chungu *et al.*, 2001; Speybroeck *et al.*, 2004, 2006), interactions of the vectors and the causative organism (Purnell *et al.*, 1971; Young *et al.*, 1984; Ochanda *et al.*, 1996, 2003a, 2003b) and the epidemiology of ECF (Norval *et al.*, 1985; Moll *et al.*, 1986; Norval *et al.*, 1992b; Billiouw *et al.*, 1999, 2002; Latif *et al.*, 2001; Fandamu *et al.*, 2005).

Notwithstanding, effective prevention and control of the disease still eludes most of the countries affected, Zambia included. This is due to, among other things, the complex epidemiology of the disease which is an intricate interplay of environmental, host and vector factors (Young, 1981; Norval *et al.*, 1991).

Norval *et al.* (1991) considered the tick vector factors of population dynamics and susceptibility of the vector population to infection with *T. parva* to be among the most important factors which influence the expression of ECF as a disease entity. Therefore an appreciation of both phenotypic and genetic variation in the vector (and indeed other biological components of the variables of epidemiology of ECF) coupled with an understanding of the mechanisms that control the genetic variation associated with the different phenotypes, may be useful in providing further insights into this complex epidemiology by shedding more light on the essential nature of tick/parasite, tick/host and tick/environment interactions.

This chapter reviews variation (genetic and phenotypic) in general i.e. the origin and nature of variation, its importance and necessity and summarizes existing information on variation in *R. appendiculatus* / *R. zambeziensis* in particular.

## 2.2 Why study variation?

The study of variation is central in the investigation of the processes that account for the history of life. Variation, especially intra-specific genetic variation provides the resources for changes within a population (Gooding, 1996; Ridley, 2004). On the other hand, variation creates uncertainty with respect to interpretation and application

of information by creating potential taxonomical and epidemiological puzzles (Besansky *et al.*, 1992; Gooding, 1996; Masumu, 2006). A good example of an epidemiological puzzle due to variation (or the seemingly lack of it!) was the anomalous outbreak of ECF in May/June (epidemics of which are normally reported in the rainy season) during years of below average rainfall in traditional cattle herds in the Southern province of Zambia due to an increase in the *R. zambeziensis* component of the morphologically difficult-to-differentiate members of the *R. appendiculatus/zambeziensis* complex (Mulumba *et al.*, 2000, 2001). In addition, the study of intra-specific variation in a vector population like *Rhipicephalus* spp., provides unique opportunities for the study of microevolution (Gooding, 1996). Vector ticks are transported on their hosts or through human activity to new localities where they might be exposed to evolutionary forces they may not have previously been exposed to. They are subjected to a variety of control measures that provide novel selective pressures leading to changes in the vector population. Knowledge of the changes in a vector population like *R. appendiculatus/zambeziensis* is vital if appropriate ECF control measures have to be developed. Therefore the study of intra-specific variation is important to understand how new species evolve and the nature of species (Besansky *et al.*, 1992; Ridley, 2004). An appreciation of the nature of species in a vector population is a major part in understanding the epidemiology of the disease they transmit.

### **2.3 Intra-specific variation**

Intra-specific variation or within species variation can be defined as the existence of individuals of distinctly different genetic and or phenotypic characters but clearly belonging to the same species. For instance different populations of *R. appendiculatus* from different latitudes and climatic conditions exhibit differences in diapausing behaviour (Madder *et al.*, 2002). Even within a population, where a population is defined as all individuals of the same species living in a defined area at the same time, no two individuals are exactly the same. Variation within individuals of a population is called polymorphism (Ridley, 2004). For example Chaka *et al.* (1999) have reported spatial polymorphism of average adult body size in a population of *R. appendiculatus* from Eastern province of Zambia and Berkvens *et al.* (1995) and Madder *et al.* (2002) have reported polymorphism in diapause behaviour in populations from the same area.

While intraspecific genetic and phenotypic variations have been accepted, the question when is variation enough to constitute another species still remains unanswered. This and the specific question what are species have given rise to a number of so called species concepts.

## **2.4 Species concepts**

Species concepts are an attempt at defining and describing what should and should not be included in the taxonomical grouping called species (Mayden, 1997). Mallet (2001) considers species concepts an endeavour at delimiting groups of organisms along natural fault lines, so that approximately the same groupings can be recovered by independent observers. Ridley (2004) on the other hand considers species concepts as endeavours at defining which individuals belong to which species at any instant in time. A definition of species that is species-concept-free would be groups of an organism that have evolved from a pre-existing species so that the progenitor and the daughter species become different from each other, so different that they can exist together without fusing, no barrier to keep them apart but their own organization. How different that is, depends on which species concepts one is using. Coyne and Orr (2004) list 25 while Mayden (1997) refers to 22 such species concepts. The multiplicity of species concepts is testimony to how elusive has been the search for that “ideal” concept that is biologically meaningful and applies to all diversity. Most species concepts are very closely related and therefore, only five concepts taken from Mayden (1997) are considered here.

### **2.4.1 Morphological species concept (MSC)**

The MSC in its current form was promulgated by Regan (1926). It categorizes species as a community or a number of related communities, whose distinctive morphological characters are, in the opinion of competent systematists, sufficiently definite to entitle it or them to a specific name. Variants of the MSC have been suggested, the most recent was by Cronquist (1978). Mayden (1997) considered the MSC as the most sensible and commonly used method of species definition by taxonomists, general biologists and laypersons alike. The strength of this concept is that it applies to both sexual and asexual species and morphology can be considered in a wider sense. This concept, however, does not treat species as historical lineages and therefore rules out transformation of one species into another (i.e. speciation). With this concept

morphologically very similar species risk being lumped into one species. An example of this limitation of this concept when applied to rhipicephalids is the assemblage of a number of species into groups viz, the *Rhipicephalus pravus* group, *Rhipicephalus appendiculatus* group, *Rhipicephalus simus* group, *Rhipicephalus sanguineus* group, *Rhipicephalus pulchellus* group and *Rhipicephalus capensis-longus* group (Walker *et al.*, 2000). This is because member species of these groups show extensive morphological variation overlapping into those of other members. The MSC may fail to recognise sibling species since no morphological differences exist between such. In addition, there may be retention of ancestral (primitive or plesiomorphic) morphologies between different unrelated groups. Further, individuals within a species vary and therefore cannot be defined based on one description of what they should look like. Nevertheless, examples exist of species description based on one specimen e.g. the initial description of *Rhipicephalus longus* Neumann 1907 was based on a single male specimen (Elbl and Anastos, 1966). Later more specimens were studied by other workers for its specific status to be upheld (Elbl and Anastos, 1966).

#### **2.4.2 Phenetic species concept (PhSC)**

The PhSC recognizes species as a set of individuals with a high degree of overall morphological similarity (determined by multivariate statistical analysis of characters) (Sokal and Crovello, 1970), separated from all other sets of individuals by a morphological gulf. Opposition to this concept is directed against its silence on the process of speciation. Secondly, if no broad morphological gulf can be detected, where will the species-dividing line be drawn? Further what reason should be given for choosing one level of phenetic similarity over any other to term the level species? Further still, phenetic classifications based on morphology introduce the danger that, if convergent characters are used as data, one may group unrelated forms into paraphyletic or even polyphyletic taxa (Mallet, 2001). Finally, single gene polymorphisms and sexual dimorphism can affect multiple morphological characters. This could lead to recognition of multiple species within polymorphic populations. Sibling species, on the other hand, could be lumped into the same species using a phenetic approach, unless a set of highly diagnostic characters could be found. The PhSC, however, is a very highly operational concept and invoked quite often by taxonomists.

### 2.4.3 The biological species concept (BSC)

According to the BSC, species are categorized as groups of actually or potentially breeding organisms that are reproductively isolated from other such groups (Mayr, 1940). There are a number of points of contention against the BSC. Firstly, the concept cannot categorize asexual species (since they do not reproduce with other individuals at all) or fossil species (it is impossible to tell what fossils could have reproduced with what other fossils). Furthermore, strong mate choice may exist within species (sexual selection) resulting in non-breeding of incompatible males and females of the same species. *Boophilus microplus* from South Africa and *B. microplus* from Australia are different populations of the same species that showed unsuccessful mating (Spickett and Malan, 1978). These authors were inclined to think of the two populations as separate species based on the BSC. However, molecular evidence (Barker, 1998) showed they are a single species. On the other hand, “good” species can and do hybridize in nature (Shoemaker *et al.*, 1996). For instance, Walker *et al.* (1981) reported *R. zambeziensis* as a distinct species from *R. appendiculatus*. Yet Berkvens (2002) found indications of a natural hybrid of these two. In which case, an application of the BSC to these two entities would give a single species. Finally, the BSC fails to define species on their own good but in relation to another group with which they must or must not breed. To its credit the BSC is able to categorize sibling species.

### 2.4.4 The evolutionary species concept (ESC)

The ESC was proposed by Simpson (1961) and modified by Wiley (1978, 1981) in which a species is a lineage (an ancestral-descendant sequence of populations) evolving separately from others and with its own unitary evolutionary role and tendencies. The strengths of the ESC are in its recognition of species as lineages in which patterns and attributes of the species can be correctly interpreted with respect to their own descent and requires no thresholds for particular attributes for the existence of the species. It recognizes both uni and bi-parentals therefore encapsulating all types of biological entities considered species. In addition, it is considered consistent with current theoretical and empirical knowledge of diversity and ontological status of entities involved in descent. For these reasons Mayden (1997) in his hierarchy of species concepts reckoned the ESC to be the primary concept and the rest as secondary. However, de Pinna (1999) considers the phrase “unitary evolutionary role

and tendencies” as one of the weaknesses of the ESC as it is considered to depend on future outcomes whose veracity or the lack of it cannot be determined in the present. In addition the ESC is non operational. Therefore the ESC to be of practical use must be invoked with more operational secondary concepts which allow recognition of entities compatible with its (ESC) intentions.

#### **2.4.5 The phylogenetic species concept (PSC)**

Phylogeny as a term refers to the evolutionary history of species, or history of speciation. A phylogenetic species is an irreducible (basal) cluster of organisms, diagnosably distinct from other such clusters, and within which there is a parental pattern of ancestry and descent (Cracraft 1983). Nixon and Wheeler (1990) refined the definition so that it extends to non-sexually reproducing organisms as “the smallest aggregation of populations (sexual) or lineages (asexual) diagnosable by a unique combination of character states in comparable individuals”. In other words, if we have a group of organisms that all share a derived character state that cannot be subdivided into smaller groups based on the shared derived character state then we have a species. Different species have different derived character states from each other. The phylogenetic species concept is based on the idea that we can tell which groups are in fact affecting each other genetically by their characteristics. If they share a unique derived characteristic not found in other groups, then they are not spreading this characteristic to other groups; if they do not have the derived characteristics found in other groups, then the other groups are not affecting them. The ability to interbreed is viewed as a shared primitive attribute of no consequence in the recognition of species as taxa. The PSC would therefore have no problem classifying *R. appendiculatus* and *R. zambeziensis* separate species despite indications that they may be interbreeding in nature (Berkvens, 2002) as long as they have different derived characteristics. Therefore the PSC can be applied to allopatric forms and non sexual and parthenogenetic forms. One of the arguments against the PSC is that it may divide species into groups based on characteristics that do not have any clear biological relevance and appear to be very minor traits (Mayr, 1982). In addition, the PSC may divide life up into an inconveniently large number of species and the species groups might not remain separate because the groups can still reproduce with each other. Thus, species defined by the phylogenetic species concept may not be permanent; they may merge together over time. Finally, the PSC will fail

to reveal sibling species as it gives no reason or incentive to search for further divisions of existing diagnosably distinct forms. However, the PSC will have no problems accommodating sibling species once revealed by another concept.

## **2.5 Speciation**

Implied in most “respected” species concepts is the origin of species or at least the history of speciation. Speciation, the evolution of two or more species from one pre-existing species, is too slow to be observed directly (Mayr, 1982). It is, therefore, impossible to study the same individual population before and after speciation. As a result the study of speciation involves a reconstruction of historical events from which are derived certain deductive generalizations whose validity are tested by “proper” comparative methods (Mayr, 1982). Further, conditions prevailing at the time of division of an ancient gene pool must be inferred and the time or period during which an ancient gene pool divided must be estimated (Avise, 2000).

Speciation models can be divided into two broad groups, i.e. geographic speciation and non geographic speciation (Mayr, 1982). Only geographic speciation is considered here.

### **2.5.1 Geographic speciation**

Five models of geographic speciation are considered (Mayr, 1982; Page and Holmes, 1998).

#### **2.5.1.1 Allopatric speciation**

This term is used to refer to geographical speciation in general and also to a classical geographical speciation model in which a species is split in two (or more) groups by geographical barrier(s). When a geographical barrier splits the range of a species the event that split the species range is called a vicarious event e.g. formation of glaciers in the ice age, continental drift or changes in water position. For instance the formation of Lake Kariba due to construction of the Kariba dam on the Zambezi River between Zambia and Zimbabwe was a vicarious event which might have split tick populations (and populations of other species) into more than one group. In other situations the two groups of the same species may be isolated by a geographical barrier because of dispersal events. Keeping with the example of Lake Kariba, it is possible that some ticks have been made to cross the lake due to human activities by for instance clinging to a host. The latter scenario may be very common for



*R. appendiculatus* and *R. zambeziensis* as history is replete with accounts of mass movement of hosts due to breed upgrading, restocking ventures, disease averting endeavours and social upheavals avoidance (Norval *et al.*, 1992). If after separation there is no contact between population(s) in the new location(s) and the original population it might result in founder effect speciation (Page and Holmes, 1998).

#### 2.5.1.2 Peripatric speciation

This is a type of geographic speciation due to peripheral isolation. It said to be very likely in species with low dispersal facilities like some tick species. Subpopulations of the species on the periphery of the range occupied by the main population may become isolated and begin to diverge genetically until reproduction isolation occurs. The process is enabled by the fact that peripheral populations are likely to be small (there is roughly an inverse relationship between population size and rate of speciation) and may have experienced bottlenecks so that genetic drift, as well as founder and inbreeding effects, will reinforce their new genetic identity (Page and Holmes, 1998).

#### 2.5.1.3 Parapatric speciation

This type of speciation is thought to occur in geographically contiguous rather than isolated populations (Page and Holmes, 1998). In this case individuals can move between the populations therefore allowing for gene flow. But gene flow makes speciation unlikely, making this model difficult to understand. It has therefore been suggested that for speciation to occur in such a situation there must be strong selection to counteract the effect of gene flow. This can happen if there is an in-situ abrupt environmental gradient in the range of a species resulting in disruptive selection of intermediates (hybrids) (Mayr, 1982). This model of speciation is thought to be very rare because of the requirement of an environment that will result in strong disruptive selection without a geographic barrier. Incidentally, existence of hybrid zones (areas where genetically distinct entities do not show complete reproductive isolation) that are flanked by races adapted to conditions different to those in the hybrid zone is used as evidence in favour of this mode of speciation (Ridley, 2004). In the range of *R. appendiculatus* and *R. zambeziensis* suspected hybrid zones (areas with specimens morphologically intermediate between *R. appendiculatus* and *R. zambeziensis*) have been reported (Zivkovic *et al.*, 1986) in areas where there is a

gentle slope from the highlands (optimal *R. appendiculatus* area) to the valley (marginal *R. appendiculatus* area where *R. zambeziensis* replaces the former). In areas where the fall is sharp such morphologically intermediate specimens have not been observed (Norval *et al.*, 1982).

#### 2.5.1.4 Sympatric speciation

According to this model of speciation reproduction isolation takes place within a single population without the help of a geographical barrier (Page and Holmes, 1998). The thorny aspect of this theory is how genetic divergence can be enhanced within a population of organisms that is continually exchanging genes. There are two main ways in which sympatric speciation is thought to occur (Mayr, 1982). The first is by ecological isolation: the barriers to gene flow in this case are ecological and physiographic parameters e.g. sympatric speciation by a shift of host preference (or loss by extinction of initial host) is a possibility. The second is strong disruptive selection within an area: this could potentially result in sympatric speciation if selection for extreme forms against intermediates is sufficiently strong so that crosses result in few surviving offspring and therefore little gene flow between the two extremes.

#### 2.5.1.5 Stasipatric speciation

A new gene arrangement may turn up anywhere within the range of a species. Gradually it becomes more and more common and spreads out from the point of origin until the number of heterozygotes has reached such a high frequency that homozygotes will finally occur (Mayr, 1982). In this model mutations happen first and then get fixed in particular deme. Any chromosomal rearrangements will result in a genetic revolution (Mayr, 1954 cited by Templeton, 1979). In species with low dispersal facilities and /or rather specific habitat requirements one can also find 'internal' founder populations anywhere within the range of the species. These may be populations colonising previously unoccupied spots within the species range. The new populations may be isolated for quite sometime and undergo peripatric speciation exactly like peripherally isolated populations.

In conclusion, the distinction between allopatric, parapatric, peripatric, sympatric and stasipatric speciation is based on the geographic distribution of the groups that have undergone speciation to become different species and not on the processes that lead to

speciation. Whether speciation occurs depends on the main forces of evolution (Futuyma, 1988) i.e. mutation and recombination, natural selection and genetic drift.

## 2.6 Reconstructing speciation

Molecular phylogenetics is the study of processes of evolution by analysis of DNA or amino acid sequences (Whelan *et al.*, 2001). Reconstructing the phylogenetic relationships between gene (DNA) sequences is a critical first step towards understanding their evolution (Page and Holmes, 1998). The sequences from which phylogenetic inference is to be made must satisfy certain conditions (Vandamme, 2003). Firstly, sequences used must be homologous (see list of definitions). Homology of sequences may be inferred from their similarity. In general, the higher the similarity, the more likely it is that the sequences are homologous. However, similarity is not equal to homology. Not only must the sequences be homologous, but also homologous sites in the sequences must be compared, hence the necessity of alignments. During alignment homologous sites in sequences are put in columns manually or by use of special software packages e.g. ClustalW (Thompson *et al.*, 1994) and ClustalX (Thompson *et al.*, 1997). Lastly if the task is to infer organismal history (as opposed to sequence history) it is important to establish that the sequences are orthologous and not paralogous (see list of definitions).

Evolutionary relationships among genes and organisms are usually illustrated by phylogenetic trees. Phylogenetic trees are mathematical structures that model the evolutionary history of sequences or organisms. The task of molecular phylogenetics is to convert information in sequences into an evolutionary tree for those sequences. A lot of methods and software packages in which these methods of converting sequence information into trees are implemented are available (Felsenstein, 1989; Adachi and Hasegawa, 1995; Yang, 1997; Swofford, 1999). These methods can be divided into those that convert aligned sequences into matrices of pairwise distances, and then use these matrices for tree building (van de Peer, 2003) and those that analyse characters separately and independently (Page and Holmes, 1998). The second classification is whether the method clusters sequences stepwise, so called stepwise clustering, resulting in only one best tree, or whether the method considers all theoretically possible trees. The latter are called exhaustive search methods (Page and Holmes, 1998). Because of the computational cost associated with exhaustive methods faster alternative search strategies, called heuristic methods have been

devised. Table 2.1 lists some three common phylogenetic-tree-building methods in use.

**Table 2.1: Some common phylogenetic tree building methods**

Method	Treatment of Data	Tree analysis strategy
Maximum likelihood (ML)	Character state	Exhaustive search
Maximum parsimony (MP)	Character state	Exhaustive search
Neighbour-joining (NJ)	Distance matrix	Stepwise-clustering

Some of the methods in Table 2.1 may have the same data treatment and tree analysis strategies; however, they differ in their assumptions. Which assumptions and strategies are the most appropriate may differ between different sequence data sets. Therefore, the methods may not arrive at the same optimal tree given the same sequence data. As such the choice of a method should depend on the particularities of one's data.

A more recent addition to the arsenal of phylogeny reconstruction tools is the Bayesian inference of phylogeny (Huelsenbeck and Ronquist, 2001).

The following is a review of the methods that were used in the current work.

### 2.6.1 Neighbour-joining

Neighbour-joining (NJ) (Page and Holmes, 1998; Whelan *et al.*, 2001; Van de Peer, 2003) is a widely used method because it is computationally fast producing only one tree. Like most clustering methods, NJ lacks a way of evaluating between competing hypotheses (trees) i.e. it does not have a measure of fit between tree and data. In addition, converting sequences into distances leads to an overall estimate between tree and data resulting in loss of information on individual sites or categories of sites on a tree. That said, the reliability of trees obtained by distance methods like NJ depends more on the method used in obtaining the distances. Good estimates of the evolutionary distance should give trees which provide a closer fit to the data. Neighbour-joining may be implemented in the software packages PHYLIP (Felsenstein, 1989) and PAUP\* (Swofford, 1999), amongst others.

### 2.6.2 Maximum parsimony

The aim in Maximum parsimony is to find the tree or collection of trees that minimize the amount of transformation of one character state into another required to explain

the data (Swofford and Sullivan, 2003). In other words one looks for a tree or group of trees that minimize evolutionary change to explain the data (Page and Holmes, 1998). This method requires no explicit assumptions, or at least it is not clear what the assumptions of parsimony analysis are, apart from the main underlying assumption of independence among characters. It is most effective when the expected amount of change is low. Parsimony analysis is faster than model based methods like ML. As such parsimony is an important alternative to the model based methods when they cannot be used due to computational limitations. Maximum parsimony is implemented in the software packages PHYLIP (Felsenstein, 1989) and PAUP\* (Swofford, 1999).

### **2.6.3 Maximum likelihood**

Maximum likelihood (ML) (Page and Holmes, 1998b; Whelan *et al.*, 2001; Haeseler and Strimmer, 2003) is a so called discrete character state method. In ML every tree topology (branching pattern) of the given data is examined and the support for each is evaluated by examining every nucleotide position. In principle ML calculates the probability of expecting each possible nucleotide in the ancestral (internal) nodes and deduces the likelihood of tree structure from these probabilities. In short, Maximum likelihood chooses the tree that of all the trees is the one that is most likely to have produced the observed data. Therefore likelihood is not the probability that the tree is the true tree, rather the probability that the tree has given rise to the data collected. This analysis is computationally very demanding but considered very consistent. The ML analysis may be implemented in the software packages PHYLIP (Felsenstein, 1989) and PAUP\* (Swofford, 1999).

Maximum likelihood requires three elements, observed data (nucleotide sequences), a tree (hypothesis) and a model of nucleotide sequence evolution. There are two approaches to building models of nucleotide sequence evolution (Page and Holmes, 1998c; Whelan *et al.*, 2001; Strimer and von Haeseler, 2003), the empirical approach and the parameterization approach. The empirical approach uses properties calculated through the use of large numbers of observed sequences resulting in fixed parameter values estimated once and then assumed to be applicable to all data sets. In contrast, models built parametrically are based on the structural and biological properties of DNA. This allows for the parameter values to be derived from the data set in each particular analysis. Software packages for parameterization of sequences in analyses

are available, e.g. Modeltest (Posada and Crandal, 1998). Three main parameters are used in these models: (1) base frequency parameters, (2) transition/ transversion ratio (Ts/Tv) otherwise known as base exchangeability parameters, (3) rate heterogeneity parameters. Base frequency is a description of the frequency of the bases A, C, G and T, averaged over all sequence sites and over the tree. Base frequency parameters represent constraints on base frequencies and act as weighting factors in a model by making certain bases more likely to arise when substitutions occur. In other words, if some bases are more frequent than others, then some substitutions may be more frequent than others. Transition/transversion parameters are a measure of the structural similarity of the bases. If the similarity among the bases is high then substitutions of one for the other may be high. For example transition substitutions (purine to purine or pyrimidine to pyrimidine) are more common than transversions (purine to pyrimidine and vice versa). Rate heterogeneity: nucleotide substitutions vary considerably among sites in a sequence resulting in considerable impact in sequence divergence. The substitution rates are influenced by biochemical factors, constraints of the genetic code and selection for gene function to name a few. For instance sites at which any nucleotide substitution results in an amino acid replacement (non-degenerate sites) have very few substitutions. In contrast genes that have lost functionality (pseudogenes) have high substitution or mutation rates. There is therefore a whole range of probabilities of substitution. This variation in substitution is modelled using a gamma distribution of rates across sequences. The gamma distribution has a shape parameter  $\alpha$  which specifies the range of rate variation among sites. Small values of  $\alpha$ , result in an L-shaped distribution with extreme variation of rates. An L-shaped distribution depicts a situation where most sites are invariable, but a few have very high rates of substitution. On the other hand, larger values of  $\alpha$  indicate a smaller range of rates. By and large, the distribution of rates tends to be L-shaped.

#### **2.6.4 Non-parametric bootstrapping**

Estimates of phylogeny based on samples will invariably be accompanied by sampling errors. Non-parametric bootstrapping is a method of estimating sampling error by re-sampling with replacement (i.e. any site sampled is returned to the data set before the next sample is taken) from the sample itself (Felsenstein, 1985). Each re-sampling is therefore a pseudo replicate. A tree is then built from this pseudo replicate

and the process is repeated several times, for example 100-2000 times. The most common splits found among the bootstrap trees can be assembled into a bootstrap consensus trees that is usually drawn with each node labelled with the frequency of its occurrence. Bootstrap analysis is a simple and effective technique to test the relative reliability of groups within a phylogenetic tree reflecting the phylogenetic signal in the data as detected by the tree construction method used (van der Peer, 2003). It is important to note that bootstrapping is a measure of how many alternative trees are excluded (precision) and not how true (accuracy) the tree is (Page and Holmes, 1998).

### **2.6.5 Bayesian inference of phylogeny**

Bayesian inference of phylogeny is implemented in the software packages like, MRBAYES (Huelsenbeck and Ronquist, 2001) and BAMBE (Simon and Larget, 1998). Bayesian estimation of phylogeny is based on a quantity called the posterior probability distribution of trees. The posterior probability of trees is the probability of the *i*th tree conditional on the observations (an alignment of DNA sequences) and is calculated using Bayes's theorem (Huelsenbeck *et al.*, 2002).

Like likelihood, Bayesian estimation of phylogeny is based on the likelihood function. However, unlike maximum likelihood, Bayesian inference of phylogeny as implemented in MRBAYES can incorporate a systematist's prior information about phylogeny through the specification of a prior probability distribution of trees.

The Bayesian posterior probabilities provide an alternative to nonparametric bootstrap analysis of ML inferences and represent the probability that the corresponding clade is true given the model, the priors, and the data (Yang and Rannala, 2005).

It can be noticed that even though there are different mechanisms of acquiring variation, only mutations (point mutation, insertions and deletions) are used by the different phylogenetic models implemented in most methods to infer relationships between genes. Therefore, it is apparent that phylogenetic inferences are made on limited data using very simplified models of evolution (relative to the process of gene evolution) (Avise, 2000) that are nonetheless computationally very challenging.

### **2.6.6 Choice of gene sequence to use in reconstruction of speciation**

Knowledge of how genes evolve is required in choosing genes or gene segments for different aspects of molecular systematics and phylogenetics. Such information form the basis for the choice of phylogeny reconstruction methods and priors in models of

evolution for particular sequence data (see item 2.6.3). Properties of an ideal gene for use as a molecular marker have been given (Simon *et al.*, 1994; Cruickshank, 2002). Some of these include the requirement that genes be single copy or multiple homogeneous copies of the same, with sufficient variation to provide enough number of informative sites and yet low enough to avoid excessive numbers of multiple substitutions. In this study three genes were used to assess species relationships among our taxa of interest; the second internal transcribed spacer (ITS2) of the nuclear genes and two mitochondrial gene segments, the 12S ribosomal DNA (mt 12S rDNA) and the cytochrome c oxidase subunit I (mt COI). The combination of the ITS2 and the protein-coding mtCOI together provide a powerful tool for phylogenetics at low taxonomic levels (Cruickshank, 2002). A review of each of these genes is thus provided.

#### 2.6.6.1 The second internal transcribed spacer (ITS2)

The ribosomal DNA (rDNA) array of the nuclear genome consists of the coding regions for the 18S rDNA, 28S rDNA and 5.8S rDNA subunits (Hwang and Kim, 1999). Together with the coding regions, rDNA array also contains a number of spacer sequences. These contain signals needed to process the rRNA transcript. The spacers include an external transcribed spacer (ETS) and two internal transcribed spacers 1 and 2 called ITS1 and ITS2 for short. When rDNA sequences are compared within and between species, they tend to show high sequence similarity between species and a significant diversity between species. This has been attributed to a process called concerted evolution, which results in redistribution of mutations to all members of the multigene family. Therefore the ITS2 is frequently used as a phylogenetic marker, because though it's a multiple-copy gene all copies have the same sequence so that it does no matter which copy is sequenced (Simon *et al.*, 1994; Cruickshank, 2002). Secondly, it has a much more variable primary sequence compared to the conserved coding flanking regions of 5.8S and 28S rDNA (Page and Holmes, 1998; Navajas and Fenton, 2000; Cruickshank, 2002). In addition, being sandwiched between two conserved coding regions of 5.8S and 28S rDNA presents relative ease of developing primers for its amplification. Further, the presence of rRNA genes in large quantities in all cells facilitates polymerase chain reaction (PCR) amplification of small or even degraded samples (Barker, 1998). And finally, as a part of the rDNA multigene family, the ITS2 shares the property of high sequence



similarity within species and high degree of divergence between species making it useful in reconstructing species relationships in closely related taxa (Zahler, 1995, 1997; Barker, 1998; Page and Holmes, 1998; Navajas and Fenton, 2000; Cruickshank, 2002).

#### 2.6.6.2 Mitochondrial 12S rDNA and Cytochrome c oxidase subunit I

Mitochondria have a genome that consists of a single DNA molecule with each gene generally appearing once (Page and Holmes, 1998; Avise, 2000). Mitochondrial genes can broadly be divided into two categories; ribosomal genes and protein coding genes. There are two mitochondrial ribosomal genes, the 12S rDNA and 16SrDNA that are not separated by internal transcribed spacers (Cruickshank, 2002). In animals mitochondria are maternally inherited. The maternal inheritance or transmission, along with the fact that mitochondrial DNA (mtDNA) does not undergo recombination, its extensive intraspecific variation and its faster evolution (compared to nuclear genome) makes mitochondria a very important study tool for systematics and population genetics (Simon *et al.*, 1994). Further because each individual displays a specifiable mtDNA haplotype inherited without intermolecular genetic recombination from the mother, individuals and not populations in a population genetic analysis could be treated as operational taxonomic units (OUT)(Avise, 2000). As such interpretations can be made without concern about sampling errors at the population level. Further still the maternal inheritance of mtDNA permits use of phylogenetic concepts to intraspecific evolution since the mtDNA gene trees are non-anastomose, but hierarchically branched due to the asexual mode of transmission. Like nuclear ribosomal DNA, mitochondrial genes have high copy numbers in a cell. This and the small genome size make mitochondria easier to manipulate and therefore highly favourable. The entire mitochondrial DNA may be considered as a single locus for purposes of phylogenetics because character states are linked by virtue of the molecule's mode of asexual transmission (Page and Holmes, 1998; Hwang and Kim, 1999; Avise, 2000). Therefore every gene has the same phylogenetic history. Nonetheless different sites and genes in the mtDNA genome evolve at widely different rates. For example protein coding genes like mtCOI evolve faster than 12SrDNA.

## **2.7 Phenotypic variation within and between *R. appendiculatus* and *R. zambeziensis***

Phenotypic variation refers to variation in any of the observable or measurable characters of an organism, i.e. morphological, behavioural, phenology including microscopic, physiological and biochemical characters which may be hard to observe or measure (Ridley, 2004).

### **2.7.1 Morphological variation**

For centuries, gross morphological variation between individuals or the lack of it (sic) has been used to group individuals into kinds e.g. Aristotle (4<sup>th</sup> Century B.C) and Linnaeus (ca. 1735). This premise has since been superseded by the knowledge of quantitative traits that produce great measurable variation in phenotype and the discovery of sibling species which are morphologically very similar individuals who nevertheless belong to different species (Page and Holmes, 1998). On the other extreme are so called polytypic species that have a number of distinct forms which forms are nonetheless a single species. Further individuals of the same species may have different morphologies depending on the stage of development. This is clearly evident in arthropods that undergo incomplete or complete metamorphosis. Three host ticks like *Rhipicephalus* spp. undergo metamorphosis when they moult from larvae to nymph and nymph to adult. Further still, not a few species exhibit sexual dimorphism which refers to morphological and/or behavioural differences between males and females of the same species. There is also the effect of climate and other environmental factors that exert substantial effect on morphological variance (Pétavy *et al.*, 2001) especially size variation which in turn affects shape or at least the interpretation of shape. Environmental morphological variance may be adaptive or plastic. Adaptive morphological variance is easier identified in polymorphic genotypes that produce discrete phenotypic variance. Individuals of a favourable phenotype in a given environment may be favoured (adapted). Plasticity refers variable phenotypic expression of the same genotype under different environmental conditions. Plasticity might be suspected when continuous phenotypic variation is associated with a polymorphic genotype. The biggest challenge therefore, for the study of morphological variation within a species is determining which variation is inherited and which is due to environmental factors (Page and Holmes, 1998). Some of the environmental factors that may result in morphological variation between

populations and in individuals of a population include altitude, latitude and geography. Individuals raised at higher altitude, hence lower temperatures tend to be bigger than those raised at lower altitude and therefore higher temperatures (Silver and Renshaw, 1999; Speybroeck *et al.*, 2004). Species whose ranges span wide latitudinal differences may be smaller in the south and become gradually bigger as one goes north. Geographic variation refers to morphological variation of populations from different areas. Clinal variation, a type of geographic variation, refers to a gradual change in some feature across geography.

Morphological characteristics that can be used to distinguish ticks in general and Rhipicephalids in particular have been well described (Walker *et al.*, 2000). Difficulties arise in distinguishing closely related species by unambiguous characters (Hunt and Hilburn, 1985). Before morphological variation in the *R. appendiculatus/zambeziensis* complex can be described a generalized description of the “typical” or idealised morphological appearance of *R. appendiculatus* and *R. zambeziensis* is necessary.

### **2.7.2 Morphological description of *Rhipicephalus appendiculatus***

*Rhipicephalus appendiculatus* was originally described by Neumann in 1901. Several redescriptions have since been given (Nuttall and Warburton, 1916; Paoli, 1916; Zumpt, 1942; Hoogstraal, 1956; Walker, 1970) and the last being Walker *et al.* (1981). The following brief description of the instars of *R. appendiculatus* is derived from Walker *et al.* (2000).

#### **2.7.2.1 Adults**

*Rhipicephalus appendiculatus* has been described as a moderate-sized reddish-brown tick.

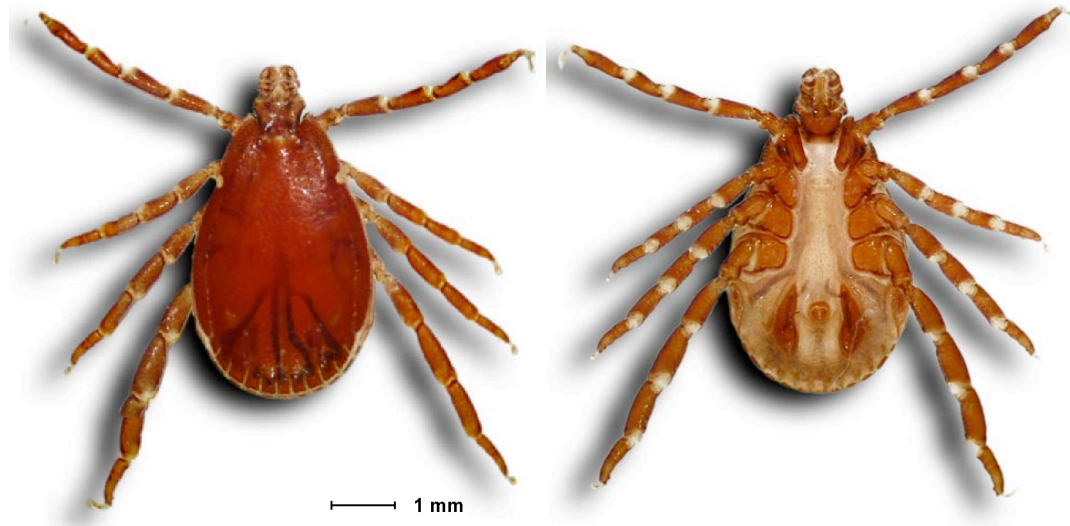

**Figure 2.1: Male *Rhipicephalus appendiculatus*: left dorsal, right ventral view**

Male specimens (fig. 2.1) are characterized by a capitulum which is a lot longer than broad. The basis capitulum is variable; much broader than long in smaller males and only slightly broader in larger males, with short obtuse lateral angles at about the anterior quarter of its length. Palps are short and broad. Coxa I has a distinctly pointed strongly-sclerotized dorsal projection called the anterior process. A dorsal shield, the conscutum, extends from the tip of the scapular process to the distal end. The conscutum has scattered and moderate sized punctations. Cervical fields are broad and depressed with finely-reticulate surfaces. The marginal lines are distinct, extending anteriorly nearly to the eye level, delimiting one festoon posteriorly. The posteromedian groove is long narrow and distinct, while the posterolateral grooves are short and broad. In smaller specimens the pattern of grooves and punctations may be much reduced. In engorged specimens a slender caudal process is formed posteromedially. Eyes are marginal, almost flat and delimited dorsally by a very shallow groove. Ventrally spiracles are broadly comma shaped curving gently towards the dorsal surface. Adanal plates are large and well sclerotized tapering posterointernally to well-rounded points. Accessory adanal plates appear as small, short sclerotized points.

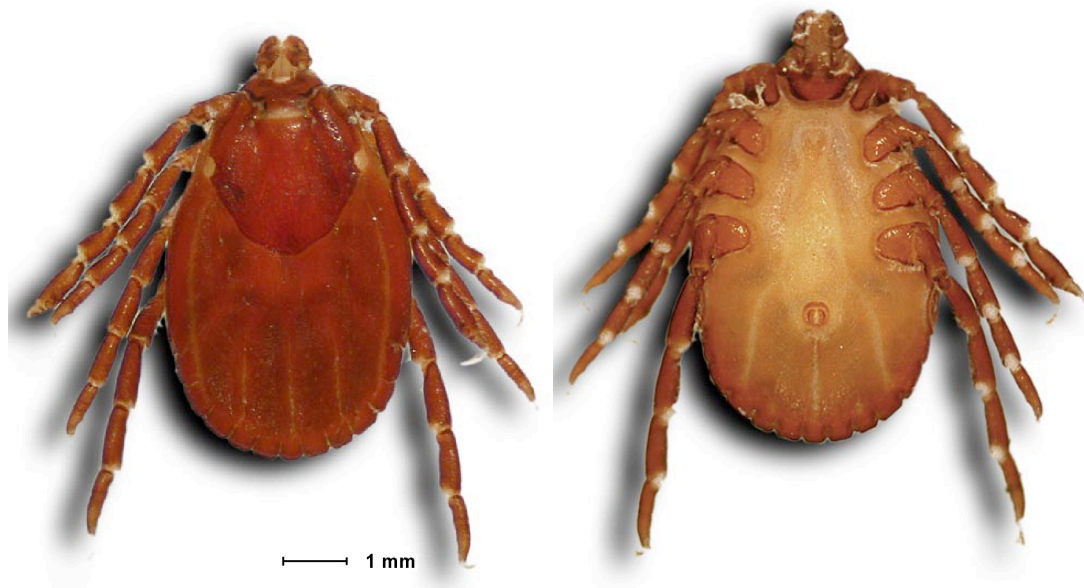

**Figure 2.2: Female *Rhipicephalus appendiculatus*: left dorsal, right ventral view**

In contrast the capitulum of females (fig. 2.2) is slightly longer than broad and the basis capitulum has broad lateral angles overlapping the scapulae. The porose areas on the basis capituli are round. Palps are short broad and bluntly rounded apically. The dorsal shield now called the scutum is longer than broad but may be approximately equal in length and width in smaller specimens. The eyes are located at the widest point of the scutum, are marginal, almost flat and are delimited dorsally by a faint groove. Cervical fields are broad and depressed.

Ventrally the genital aperture is shaped like the tip of the tongue.

#### 2.7.2.2 Nymphs

Nymphs have a capitulum that is wider than it is long (fig. 2.3). Their basis capitulum is approximately twice as broad as it is long. The lateral angles of the basis capitulum are in the anterior half of its length. Ventrally the basis capitulum has short blunt spurs on the posterior margin. Palps are short and broadly rounded apically. The scutum is wider than it is long with the posterior margin forming a broad smooth curve. Eyes are located at the widest point of the scutum, are mildly convex and are dorsally delimited by a shallow groove. The cervical fields are broad and slightly depressed and extend almost to the posterior margin of the scutum. Ventrally each coxa I has a long narrow external spur and a shorter broader internal spur; coxae II to IV each with a short sharp external spur only.

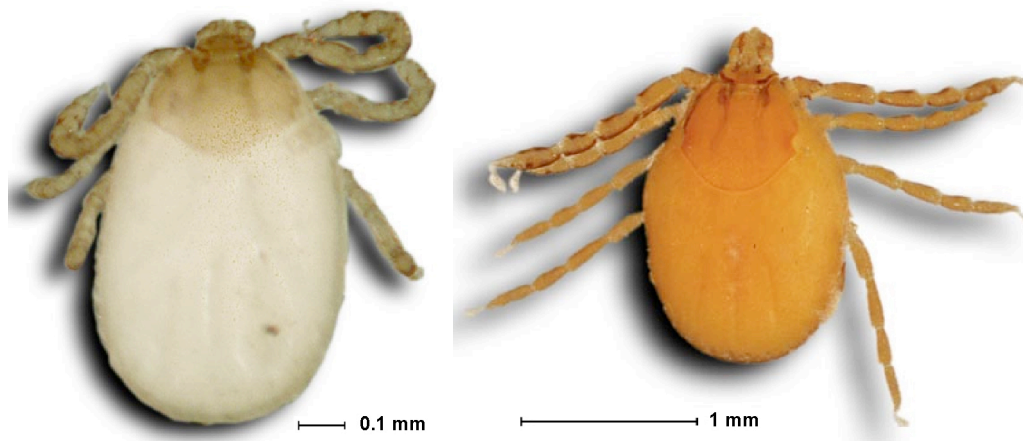

**Figure 2.3: *Rhipicephalus appendiculatus*: dorsal view of larva (left) and nymph (right)**

### 2.7.2.3 Larvae

The larval capitulum is broader than long (fig. 2.3). The width of the basis capitulum is a little over two times longer than the length with very short blunt lateral angles. Palps are constricted proximally and flattened apically. The scutum is much broader than long forming a smooth broad curve at the posterior margin. Eyes are at the widest point of the scutum, almost flat and delimited dorsally by a faint groove. Cervical grooves are short and slightly convergent. Ventrally coxa I each has a broad blunt spur; coxae II and III each with a broad ridge-like spur.

The above descriptions notwithstanding, it should be noted that like other rhipicephalids *R. appendiculatus* shows a wide range within-species variation in morphological appearance (Walker *et al.*, 2000). Factors affecting the wellbeing of immature stages cardinal of which is nutrition have a major effect on morphological variation within a species (Warburton, 1912; Nuttal, 1913; Hoogstraal, 1956). Nutrition may be affected by crowding on the host, non availability of suitable hosts and degree of host resistance to tick feeding. The result is morphological variations of the shape of the basis capituli, punctation of the (con) scutum (Walker *et al.*, 2000) and robustness (Hoogstraal, 1956). Variation in size has been observed in geographically differentiated populations of *R. appendiculatus* (Speybroeck *et al.*, 2004). Within the same geographical area specimens collected in the hotter and drier valley areas tend to be smaller (Chaka *et al.*, 1999) and more punctate than those collected on the wetter and cooler plateau areas. In some areas with a more than one

adult phenology per year there is variation in size of the different temporal adult groups (Chaka *et al.*, 1999).

### 2.7.3 Morphological description of *R. zambeziensis*

*Rhipicephalus zambeziensis* was first called *Rhipicephalus* spp.II by Yeoman and Walker (1967). It was described as a separate species by Walker *et al.* (1981).

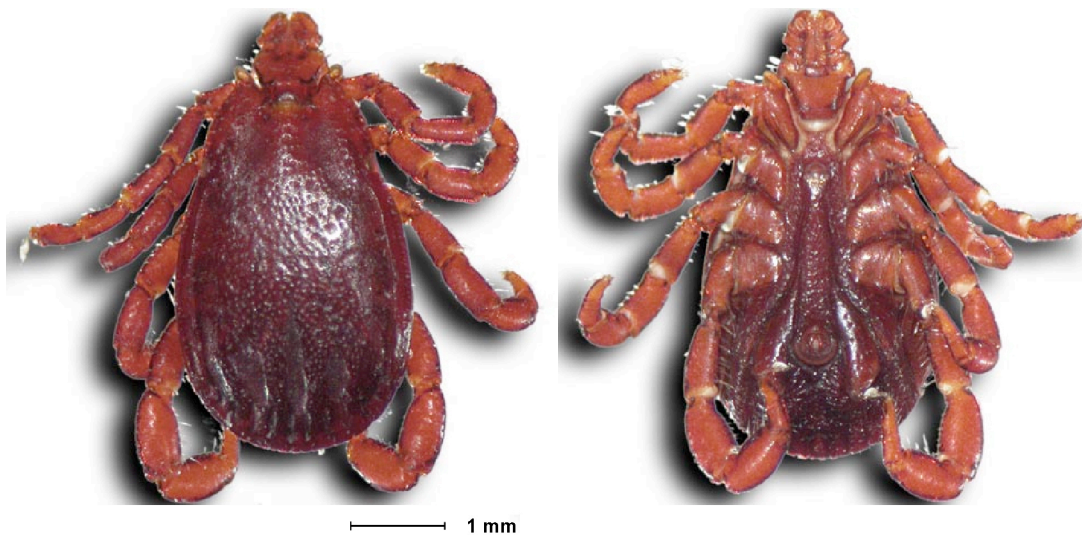

**Figure 2.4: Male *Rhipicephalus zambeziensis*: left dorsal, right ventral view**

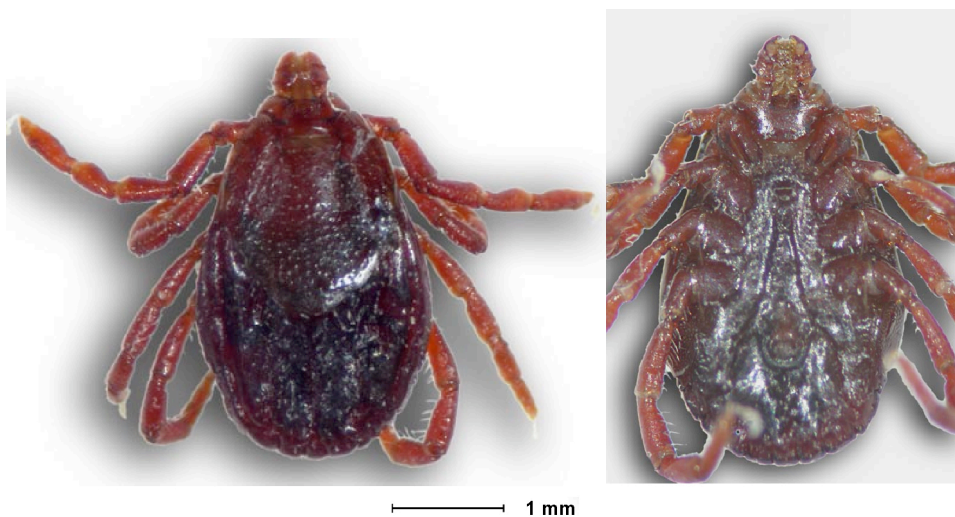

**Figure 2.5: Female *Rhipicephalus zambeziensis*: left dorsal, right ventral view.**

#### 2.7.3.1 Adults

*R. zambeziensis* is described as a moderate-sized brown tick whose capitulum is longer than broad (fig. 2.4 and 2.5). The basis capitulum has short sharp lateral angles at anterior third of its length. Palps are short and broad with slightly flattened to

gently rounded apices. Engorged male specimens have a tail like posteromedially caudal process. Eyes are marginal, almost flat and edged by a shallow groove. Cervical fields are broad, depressed with finely shagreened surfaces. Marginal lines are well developed. The posteromedian groove is long and narrow and posterolaterals are shorter and broader. Conscutal punctations are usually discrete but may be dense and coalesce in some places. Ventrally spiracles elongate with a tapering slightly curved dorsal prolongation. Adanal plates are long, narrow and tapering posterior to the anus to narrowly rounded posterointernal angles. Very small sclerotized points represent accessory adanal plates. The females of *R. zambeziensis* have a capitulum that is wider than it is long and a basis capitulum with broad lateral angles in anterior third of its length. The porose areas of the basis capitulum are oval and at times slightly irregular in shape. Palps are broad and blunt apically. The scutum is mostly as broad as it is long with a sinuous posterior margin. Eyes are about half way back, marginal, almost flat and delimited dorsally by a rather deep groove with few large punctations. The punctation pattern is generally dense. On the ventral side the genital aperture is wide with a straight posterior margin that curves forward laterally.

#### 2.7.3.2 Nymphs

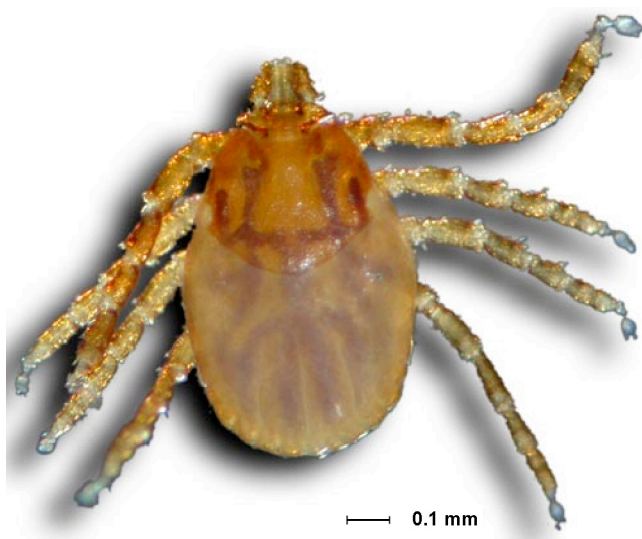

**Figure 2.6: *Rhipicephalus zambeziensis* nymph: dorsal view**

Nymphs of *R. zambeziensis* have a much broader than long capitulum (fig. 2.6). The basis capitulum is over three times as broad as long with lateral angles about mid-length, long, tapering and sharply pointed. On the ventral side the basis capitulum has bluntly rounded spurs on the posterior border. Palps are round tapering to rounded



apices. The scutum is broader than long and has a broad smooth curve at the posterior margin. Eyes, slightly convex and edged dorsally by a shallow groove are located at the widest point of the scutum. Cervical fields are long narrow and depressed. Ventrally each of the coxa I has a long tapering external spur and a shorter broader internal spur. Coxae II to IV each have a sharp external spur only.

#### 2.7.3.3 Larvae

Larvae capitulum is broader than long while the basis capitulum is over twice as broad as long with short, sharp and slightly forwardly directed lateral angles at about mid-length. Palps are broad and truncated apically. The scutum is much broader than long with a wide smooth-curved posterior margin. Eyes are slightly convex, edged dorsally by a shallow groove and are located at the widest point of the scutum. Cervical grooves are short and slightly convergent. Ventrally each coxa has a single spur. The spurs on coxa I are largest and sharpest, while those on coxae II and III are smaller and blunter.

Deviations from the picture painted above are influenced by the same factors as discussed under *R. appendiculatus* (see section 2.6.2.3). However, Speybroeck *et al.* (2004) did not find differences in the average size of *R. zambeziensis* males from populations at different latitudes.

#### 2.7.4 Morphological variation between *R. appendiculatus* and *R. zambeziensis*

From the above descriptions it is clear that there is very little morphological differentiation between the two taxa (Walker *et al.*, 2000). As if that was not enough the wide variations in morphology in both *R. zambeziensis* and *R. appendiculatus* lead to overlaps in the two taxon's morphological features rendering the above differences powerless in discriminating between the two taxa unless a wholistic approach is used i.e. a number of specimens should be examined combining morphology, host preference, predilection site, origin of specimens (Berkvens *et al.*, 1998; Walker *et al.*, 2000). Generally however, *R. zambeziensis* is smaller and darker than *R. appendiculatus*. The primary feature distinguishing the adults of *R. zambeziensis* from *R. appendiculatus* is the density of the punctation pattern, which is usually lighter in *R. appendiculatus* than in *R. zambeziensis*. Female adults of *R. zambeziensis* have a genital aperture with posterior broad U-shaped lips compared to broad V-shaped lips in *R. appendiculatus* (Walker *et al.*, 1981) (fig. 2.7). Immature stages of

the two species differ in the proportions of their basis capituli and the shape of their palps (Walker *et al.*, 1981). The lack of very clear morphological differentiating markers is one reason questions have been raised as to whether the two nominal taxa are “good” species (Speybroeck *et al.*, 2002; Madder *et al.*, 2005).

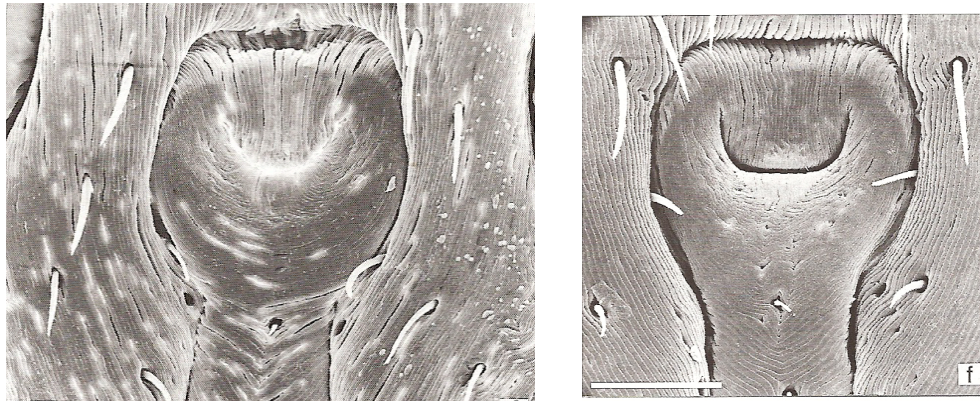

**Figure 2.7: Genital aperture of female *Rhipicephalus appendiculatus* (left) and *Rhipicephalus zambeziensis* (right) (Walker *et al.*, 2000)**

### 2.7.5 Cellular variation

Cellular variation is a kind of microscopic morphological variation. Within a species of ticks variable numbers of chromosomes have been reported (Sonenshine, 1991). Rhipicephalinae though show relatively uniform pattern of chromosome numbers (Oliver, 1983). Variations may also occur in chromosome morphology especially banding patterns and have been used in discriminating between different species of ticks and in evaluating species relations (Gunn and Hilburn, 1990).

### 2.7.6 Biochemical variation

Phenotypic variation includes variation at the biochemical level, such as proteins. Study of protein variation has been employed as an indirect approach to genetic analysis (Baliraine *et al.* 2000), since all proteins are gene products (Suzuki *et al.*, 1986). Protein variation can be studied directly or by electrophoretic techniques. Electrophoretic techniques have proved very valuable in many a species not only to discriminate between closely related species (Sukowati *et al.*, 1999; Torres *et al.*, 2006) but also to discern patterns of genetic variability which would suggest a mating substructure within a species (Hunt and Hilburn, 1985; Gooding *et al.*, 1991). However, electrophoretic techniques depend on the use of fresh specimens (Navajas and Fenton, 2000) and interpretation of their results may be controversial (Hunt and Hilburn, 1985; Gooding, 1996; Navajas and Fenton, 2000). Difficulties in

interpretation of results arise because for protein variations to be useful as taxonomical characters it must be demonstrated that they are not induced by either external or internal factors but originate from constantly expressed genetic factors (Hunt and Hilburn, 1985). Electrophoretic techniques have not been used as much in ticks as in other species considering the former's relative importance as vectors (Hunt and Hilburn, 1985). In ticks electrophoretic techniques have been used to distinguish species within the genus *Amblyomma* using acid phosphatase (ACPH) and peptidase (PEP-1) (EC.3.4.11) and species within *Dermacentor* could be distinguished with peptidase phenotypes (Hunt and Hilburn, 1985). Using esterase (EST) (EC.3.1.1) isozymes as genetic markers, Peng *et al.* (1973) investigated *Boophilus microplus* for inherent organophosphate resistance. Other electrophoretic studies have included determination of patterns of genetic variation in the Australian reptile ticks (Bull *et al.*, 1984). In *R. appendiculatus* and *R. zambeziensis* Wouters *et al.* (1987) used enzyme electrophoresis to differentiate between them revealing varied glucose-phosphate-isomerase (GPI) (EC.5.3.1.9) and mannose-phosphate-isomerase (MPI) (EC.5.3.1.8) zymogram profiles for the two taxa. Wouters (1989) also demonstrated different GPI zymogram patterns for *R. appendiculatus* and 22% (14/18) of the F<sub>1</sub>-hybrids of the cross of *R. appendiculatus* males and *R. zambeziensis* females. Baliraine *et al.* (2000) similarly demonstrated protein variation in two distinct *R. appendiculatus* populations from Kenya by the use of two-dimensional gel electrophoresis. The two populations were characterised by ca.66% common proteins. On the other hand, there were 12.5% and 20.8% proteins specific to the two populations respectively. These authors speculated a link between this variation and vector competence of the two populations. As yet, however, no causal relationship has been established between this variation and the phenotype in question. Wang *et al.* (2001) have reported considerable polymorphism in salivary gland proteins of unfed and fed *R. appendiculatus* which they hypothesized had something to do with differential engorgement success in a population of co-feeding ticks.

### **2.7.7 Behavioural variation**

Similarity in behavioural traits among organisms has been recognized as probably being due to the sharing of similar evolutionary histories. However, the challenge for comparative behavioural studies between species has been how to establish that the given behaviour(s) are derived from the same (or corresponding) feature of their

common ancestor (homology). This is due to the abstract nature of behaviour, the impossibility of deriving behaviour from the fossil record and the high incidence of behavioural convergence (Atz, 1970). These difficulties, however, were countered by Wenzel (1992) and De Quieroz and Wimberger (1993) and they may not arise for intra-specific studies. Several behavioural characteristics have been used in reconstructing arthropod phylogenies (Wimberger and de Quieroz, 1996). They are divided into actual behaviour and end products of behaviour (Stuart and Hunter, 1998). Actual behavioural characteristics include, reproductive behaviour, feeding and general lifestyles while phenology may be viewed as an end product of behaviour.

#### 2.7.7.1 Diapause

Behavioural diapause has been demonstrated in *R. appendiculatus* but not in *R. zambeziensis* (Berkvens *et al.*, 1995, Madder *et al.*, 1999). However, within *R. appendiculatus* there is variation in diapause ranging from complete absence to obligate exhibition (Madder *et al.*, 2002). For that reason Madder *et al.* (2002) were inclined to think of diapause as a possible polygenic trait i.e. produced by small effects of many loci acting in concert (Page and Holmes 1998). There are also variations in the cues for both initiation and termination of diapause (Madder *et al.*, 1999). These variations in behavioural diapause have a geographical pattern (Madder *et al.*, 2002). The presence of diapause may be used to rule out *R. zambeziensis*. However, non demonstration of diapause does not confirm *R. zambeziensis*. This behavioural characteristic therefore lacks power to discriminate between these two taxa. Besides the demonstration of diapause in the laboratory is a very difficult phenomenon (Madder and Berkvens, 1997; Madder *et al.*, 1999) and can not therefore be used as a routine diagnostic technique for the two morphologically closely related species.

#### 2.7.7.2 Vector competence

*Rhipicephalus appendiculatus* stocks vary in their vector competence for *T. parva*. For example *R. appendiculatus* stocks from Eastern province were found to be superior in vector competence for *T. parva* (Muguga and Boleni) than stocks from Southern province (Ochanda *et al.*, 1998). And Tempia (1997) has reported higher infection rates for *T. parva* (Chitongo-Southern province of Zambia) in

*R. appendiculatus* from Eastern province than *R. appendiculatus* from Southern province. Tempia (1997) attributed the higher vector competence in the *R. appendiculatus* stock from Eastern province to the difference in the geographic origins of the *T. parva* (Chitongo) and the tick. This is because exotic vectors are less adapted to the parasite and therefore show higher infections. Similar reasons were given for higher infections in *R. appendiculatus* (Keemba-Southern province) stock with *T. parva* (Katete-Eastern province) than in *R. appendiculatus* (Wafa-Eastern province) stock. Keemba stock was, however, later characterised as an *R. zambeziensis* stock (Madder *et al.*, 2005). Blouin and Stoltz (1989) compared the infection rates of *R. appendiculatus* and *R. zambeziensis* for *T. parva* (buffalo derived). Significantly higher infection rates were observed in *R. zambeziensis*. Mulumba *et al.* (2000) observed higher infection rates in the nymphs of *R. zambeziensis* than *R. appendiculatus* during larval to nymphal transmission. These observations seem to indicate that *R. zambeziensis* has a better vector competence for *T. parva* than *R. appendiculatus*. Therefore the observations by Tempia (1997) could be due to a combination of factors i.e. the difference in geographical origin of the infecting stock of *T. parva* and the vector tick as these authors rightly pointed out and the inherently higher vectorial competence for *T. parva* of *R. zambeziensis* and the Eastern province *R. appendiculatus* stocks over Southern province stocks as observed by Ochanda *et al.* (1998) and Blouin and Stoltz (1989) respectively.

#### 2.7.7.3 Host preference and predilection sites

All development stages of *R. appendiculatus* have been found on most major domestic species like sheep, goats, horses and cattle, while cattle seem to be the only preferred domestic host of all instars of *R. zambeziensis* (Norval *et al.*, 1982). Adults of both *R. appendiculatus* and *R. zambeziensis* parasitize a wide range of wild animals. However, Norval *et al.* (1982) did not find *R. zambeziensis* on Waterbuck (*Kobus ellipsiprymnus ellipsiprymnus*). In all these hosts the preferred site of attachment of adults of both *R. appendiculatus* and *R. zambeziensis* are the inside of the pinna of the ear followed by the head. Other parts of the body may be parasitized especially when the tick burden is high. Nymphs commonly attach on the outside of the pinna of ears, head and legs. Larvae mostly attach to the dewlap, head, legs and feet. Immatures of *R. zambeziensis* on Impala seem to prefer the lower legs and feet (Norval *et al.*, 1982).

There are indications that in the laboratory, adults of *R. zambeziensis* (from Zambia) do not feed on rabbits (Madder, 2000 personal communication). The drastic reduction in engorgement weights of adult *R. zambeziensis* recorded by Fivaz and Norval (1989) on successive infestations on rabbits makes the observation more likely. In their studies Zivkovic *et al.* (1986) and Fivaz and Norval (1989) observed positive feeding behaviour between males of *R. appendiculatus* and females of *R. zambeziensis*. The feeding of males of *R. zambeziensis* on the other hand did not aid the feeding of females of *R. appendiculatus*. These suspected anomalous variations in feeding behaviour need further investigation.

### 2.7.8 Phenology

The phenology of *Rhipicephalus appendiculatus* in Zambia has been well documented (MacLeod, 1970; MacLeod and Colbo, 1976; MacLeod *et al.*, 1977, MacLeod and Mwanaumo, 1978; Pegram *et al.*, 1986; Berkvens *et al.*, 1998; Chaka *et al.*, 1999; Speybroeck *et al.*, 2002) and throughout the range of the species (Yeoman, 1966; Short and Norval, 1981; Paine, 1982; Tatchell and Easton, 1986). *Rhipicephalus appendiculatus* stocks from most parts of Zambia have a single adult phenology except for the eastern province where a bimodal phenology has been reported (Berkvens *et al.*, 1998, Chaka *et al.*, 1999). *Rhipicephalus appendiculatus* stocks from the southern African countries of Zimbabwe and South Africa show a single adult phenology too. Countries in east Africa and further north have a whole range of phenologies from unimodal to multimodal.

Norval *et al.* (1982) have described the phenology of *R. zambeziensis* in Zimbabwe as almost synchronous with that of *R. appendiculatus*. The relative numbers of *R. zambeziensis* however tend to reduce more gradually than those of *R. appendiculatus* as the hot dry period approaches. This has been attributed to the higher survival of *R. zambeziensis* in hotter and drier conditions and its longer developmental periods (Madder *et al.*, 2005). But it can also be due to the fact that *R. zambeziensis* feeds later in the hot season than *R. appendiculatus*. In South Africa Horak has observed that *R. zambeziensis* feeds a month later than *R. appendiculatus* (Madder, 2005 personal communication). Speybroeck *et al.* (2002) reported the phenology of *R. zambeziensis* in Zambia as synchronous with that of *R. appendiculatus*. The biology of this species and life cycle traits (Madder *et al.*, 2005) suggest a possibility of differences in phenologies. *Rhipicephalus zambeziensis*

phenology in Zambia should be revisited if only the problem of identification is solved.

### **2.7.9 Ecological variation**

Preference for and suitability and/or ability to exploit a particular ecological niche have been associated with different species. In addition, different populations of a species may thrive in different ecological conditions. The ecological conditions are defined by both abiotic and biotic factors. Abiotic factors may include seasonally induced changes in the habitat, physiology and climatic cues. These in turn may depend on such factors as the geographic location, latitude, temperatures and large scale weather movements e.g. El Niño (Fandamu *et al.*, 2005). Biotic factors include biology and physiology of the species, life cycle, host range and availability and the existence of both intra and extra species competition. The ecologies of *R. appendiculatus* and *R. zambeziensis* are very similar; sharing hosts, similar phenology and even occurring sympatrically (Norval *et al.*, 1982, Speybroeck *et al.*, 2002). The similarities in their ecologies raises the question are *R. appendiculatus* and *R. zambeziensis* good species or mere ecological variants (ecomorphs) of the same species (Speybroeck *et al.*, 2002)?

### **2.7.10 Distribution**

*Rhipicephalus appendiculatus* has been reported in 17 countries of eastern, central and southern Africa (fig. 2.8). *Rhipicephalus zambeziensis* has been reported in parts of Tanzania, Zambia, Angola, Namibia, Botswana, Zimbabwe, Mozambique and South Africa in areas where the ecological conditions are not suitable for *R. appendiculatus* (Walker *et al.*, 2000) (fig. 2.8). The distributions of the two species seem to be influenced very strongly by relative humidity (Norval *et al.*, 1982; Walker *et al.*, 2000; Speybroeck *et al.*, 2002; Madder *et al.*, 2005). Classically *R. appendiculatus* is said to be found in higher cooler areas and is replaced by *R. zambeziensis* in lower, drier hotter areas. The mechanisms by which *R. zambeziensis* survives harsh conditions (high ambient temperatures and low humidity) without diapause (at least not in the adult stage) have never been clarified.

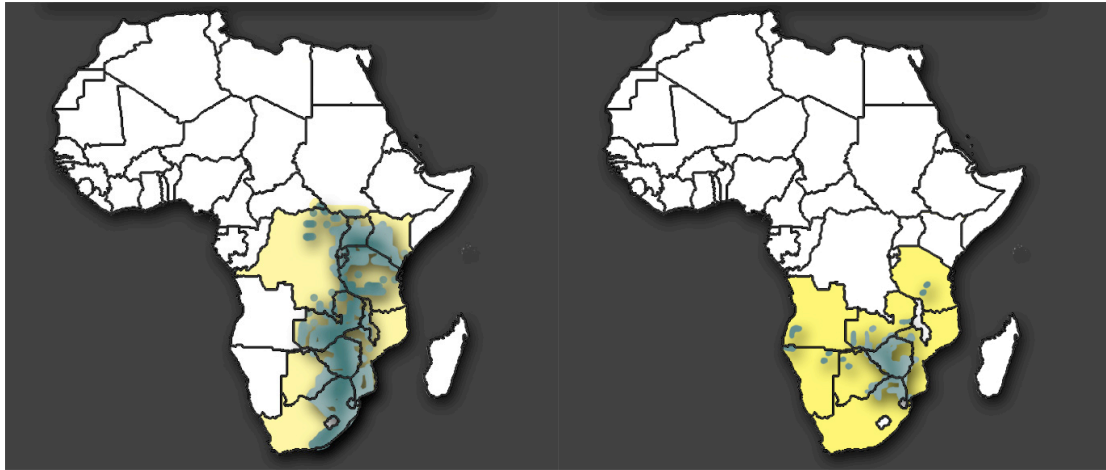

**Figure 2.8: Distribution of *Rhipicephalus appendiculatus* (left) and *Rhipicephalus zambeziensis* (right)**(<http://www.itg.be/photodatabase>)

In Zambia collections of *R. appendiculatus* have been reported in all provinces (Akafekwa, 1976). However, within a province some districts or portions within a district may be free of *R. appendiculatus*. This may be due to the unfavourable microclimate modulated by vegetation and humidity. For its part *R. zambeziensis* has been reported in the major depressions of the Luangwa and Zambezi river valley systems (MacLeod *et al.*, 1977; MacLeod, 1978). However, there have been recent reports of this tick on the plateau areas of Nteme and Keemba in Monze district of Southern province (Speybroeck *et al.*, 2002).

In the southern province of Zambia *R. appendiculatus* and *R. zambeziensis* co-occur in the same areas and on the same host at the same time (Speybroeck *et al.*, 2002). The two species tend to co-occur in areas where the increases in altitude from the river valley systems to the plateau are gradual (Norval *et al.*, 1982). Such areas of sympatry are largest in Zambia (Zivkovic *et al.*, 1986). While *R. appendiculatus* in Zambia has been found in the lowest and driest places where *R. zambeziensis* has been found, the latter on the other hand has not been found at the highest altitude where *R. appendiculatus* has been found (own observation). The presence or absence of *R. zambeziensis* in Eastern province of Zambia is still a matter of debate and therefore requires clarification. There have been reports (Norval *et al.* 1982; MacLeod and Mwanaumo, 1978) and counter reports (Berkvens *et al.*, 1998) of the presence of *R. zambeziensis* in Eastern province.



### **2.7.11 Life cycle traits**

The life cycles of the two species are very similar (see fig.1.5). Generally, developmental periods of *R. zambeziensis* tend to be longer than those of *R. appendiculatus* (Walker *et al.*, 1981; Madder *et al.*, 2005). However, within each species there are variations in the duration of the different stages of the cycle depending on temperature, humidity and day length (Madder *et al.*, 2005; Norval *et al.*, 1982). *Rhipicephalus zambeziensis* females lay more eggs than *R. appendiculatus* (Zivkovic *et al.*, 1986). In spite of that it has been observed in Zimbabwe and Zambia that *R. appendiculatus* tends to maintain higher abundance levels on cattle than *R. zambeziensis* (Norval *et al.*, 1982).

## **2.8 Genetic variation**

### **2.8.1 Source and nature of genetic variation**

Mutations (Ridley, 2004a; Watson *et al.*, 2004a) are one of the sources of new variability in genes allowing organisms to adapt to a constantly changing physical and biological environment (Ridley, 2004; Watson *et al.*, 2004a). Mutations include all possible changes in DNA sequences that arise from a number of factors. These include errors of replication and damage to DNA by environmental factors like radiation and mutagens (Watson *et al.*, 2004a). Another source of variability in the genes is homologous recombination (HR) (Watson *et al.*, 2004b).

Genetic variation has been studied through protein (enzyme) electrophoresis, DNA restriction enzyme techniques and direct DNA nucleotide sequencing methods.

### **2.8.2 Genetic variation within *R. appendiculatus***

Barker (1998) demonstrated considerable genetic diversity within the second internal transcribed spacer (ITS2) of *R. appendiculatus* in the context of distinguishing different populations of the species. Each of the seven populations (2 from Kenya, 3 from Zambia and 2 from Zimbabwe) studied had a unique consensus nucleotide sequence.

### **2.8.3 Genetic variation within *R. zambeziensis***

As in *R. appendiculatus*, Barker (1998) found considerable diversity in the ITS2 consensus sequences of three populations of *R. zambeziensis* from Zimbabwe.

#### **2.8.4 Genetic variation between *R. zambeziensis* and *R. appendiculatus***

Barker (1998) reported unambiguous distinction between the second internal transcribed spacers (ITS2) of *R. appendiculatus* and *R. zambeziensis*.

It is clear from the above that there is a dearth of data on DNA genetic variation in populations of *R. appendiculatus* and *R. zambeziensis* in Zambia and in other places where this tick is found.

### **2.9 Conclusion**

Natural populations show variation from gross morphology to DNA sequences. Ecological variation in *R. appendiculatus* and *R. zambeziensis* has been studied more extensively compared to genetic variation. Most studies in genetic variation in ticks have involved clarification of systematic relationships at higher levels. There are more indirect studies of intraspecific genetic variation in ticks based on protein electrophoresis techniques than direct measurement of DNA variability through restriction enzyme techniques or indeed direct nucleotide sequencing. This is despite the current advances in molecular biology techniques. DNA nucleotide variability provides the highest resolution of variation in any taxa. Application of phylogenetic techniques on such high resolution data might reveal better relationships of the different DNA variants and provide a basis for exploration of the mechanisms of their differentiation. The necessity to identify and describe this (DNA) variation can therefore not be gainsaid.

## 2.10 References

- Adachi, J and M. Hasegawa. 1995. MOLPHY: Programs for molecular phylogenetics ver2.3. Institute for Statistical Mathematics, Tokyo.
- Akafekwa, G. 1976. Control of tick-borne diseases in Zambia with special emphasis on East Coast fever. Bulletin de l'Office International des Epizooties, 86, 105-116.
- Atz, J. W. 1970. The application of the idea of homology to behavior (pp 53-74). In, L. R. Aronson, E. Tolbach, D. S. Lehrman, J. S. Rosenblatt (eds.). Development and Evolution of Behavior. San Francisco: Freeman.
- Avise, J.C. 2000. Phylogeography: the history and formation of species, pp 447. Harvard University Press, Cambridge, Massachusetts and London.
- Baliraine, F.N., E.O. Osir, S.B. Obuya and F.J. Mulaa. 2000. Genetic variation in *Rhipicephalus appendiculatus* (Acari: Ixodidae) populations in Kenya, assessed by two-dimensional gel electrophoresis. Insect Science and its Application, 20, 227-231.
- Barker, S.C. 1998. Distinguishing species and populations of Rhipicephaline ticks with ITS 2 ribosomal RNA. Journal of Parasitology, 84, 887-892.
- Berkvens, D.L., R.G. Pegram and J. Brandt. 1995. A study of the diapausing behavior of *Rhipicephalus appendiculatus* and *Rhipicephalus zambeziensis* under quasi-natural conditions in Zambia. Medical and Veterinary Entomology, 9, 307-315.
- Berkvens, D.L., D.M. Geysen, G. Chaka, M. Madder and J.R.A. Brandt. 1998. A survey of the ixodid ticks parasitizing cattle in the Eastern Province of Zambia. Medical and Veterinary Entomology, 12, 234-240.
- Berkvens, N. 2002. Differentiatie van teken van het *Rhipicephalus appendiculatus/R. zambeziensis* complex uit Zambia. Scriptie voorgedragen tot het behalen van de graad van Bio-ingenieur in de Landbouw, Ghent University.
- Besansky, N.J., V. Finnerty and F.H. Collins. 1992. Molecular perspectives on the genetics of mosquitoes. Advances in Genetics, 30, 123-184.
- Billiouw, M., L. Mataa, T. Marcotty, G. Chaka, J. Brandt and D. Berkvens. 1999. The current epidemiological status of bovine theileriosis in eastern Zambia. Tropical Medicine and International Health, 4, A28-A33.
- Billiouw, M., J. Vercruysse, T. Marcotty, N. Speybroeck, G. Chaka and D. Berkvens. 2002. *Theileria parva* epidemics: a case study in eastern Zambia. Veterinary Parasitology, 107, 51-56.
- Blouin, E.F. and W.H. Stoltz. 1989. Comparative infection rates of *Theileria parva lawrencei* in salivary glands of *Rhipicephalus appendiculatus* and *Rhipicephalus zambeziensis*. Onderstepoort Journal of Veterinary Research, 54, 211-213.
- Bull, C.M., R.H. Andrews and M. Adams. 1984. Patterns of genetic variation in a group of parasites, the Australian Reptile ticks. Heredity, 53, 509-525.

- Chaka, G., M. Billiouw, D.M. Geysen and D.L. Berkvens. 1999. Spatial and temporal variation in *Rhipicephalus appendiculatus* size in eastern Zambia. *Tropical Medicine and International Health*, 4, A43-A48.
- Chungu, H., N. Speybroeck, R.G. Pegram and D.L. Berkvens. 2001. *Rhipicephalus appendiculatus* burdens on cattle in relation to age and sex of the host. *Tropicultura*, 19, 34-36.
- Coyne, J.A. and H.A. Orr. 2004. *Speciation*. Sinauer Associates, Inc., Sunderland, Massachusetts.
- Cracraft, J. 1983. Species concepts and speciation analysis. *Current Ornithology*, 1, 159-187.
- Cronquist, A. 1978. Once again what is a species? (pp3-20). *In*: Knutson, L. (ed). *Biosystematics in Agriculture*, Alleheld Osmun, Montclair, NJ.
- Cruickshank, R.H. 2002. Molecular markers for the phylogenetics of mites and ticks. *Systematic & Applied Acarology*, 7, 3-14.
- De Pinna, M.C.C. 1999. Species concepts and phylogenetics. *Reviews in Fish Biology and Fisheries*, 9, 353-373.
- De Quieroz, A. and P.H. Wimberger. 1993. The usefulness of behaviour for phylogeny estimation: levels of homoplasy in behavioural and morphological characters. *Evolution*, 47, 46-60.
- Elbl, A. and G. Anastos. 1966. Ixodid ticks (Acarina, Ixodidae) of Central Africa Volume III Genus *Rhipicephalus* Koch, 1844. Koninklijk Museum voor Midden-Afrika, Tervuren, België *Annalen-----Reeks In-8°---Zoologische Wetenschappen* –nr 147, 1966.
- Fandamu, P., L. Duchateau, N. Speybroeck, T. Marcotty, V. Mbaio, J. Mtambo, M. Mulumba and D. Berkvens. 2005. *Theileria parva* sero-prevalence in traditionally kept cattle in Southern province of Zambia and El Niño. *International Journal for Parasitology*, 35, 391-396.
- Felsenstein, J. 1985. Confidence limits on phylogenies: an approach using the bootstrap. *Evolution* 39:783–791.
- Felsenstein, J. 1989. PHYLIP (Phylogeny Inference Package) ver 3.2. *Cladistics*, 5, 164-166.
- Fivaz, B.H. and A. Norval. 1989. Observations on successive infestations of the rabbit host by the ticks *Rhipicephalus appendiculatus* and *R. zambeziensis* (Acari: Ixodidae). *Experimental and Applied Acarology*, 7, 267-269.
- Futuyma, D.J. 1988. *Evolutionary Biology*, 2<sup>nd</sup> Edition. Sinauer Associates, Inc., Sunderland, Massachusetts.
- Gooding, R.H., S.K. Mooloo and B.M. Rolseth. 1991. Genetic variation in *Glossina brevipalpis*, *G. longipennis* and *G. pallidipes* and the phenetic relationships of *Glossina* species. *Medical and Veterinary Entomology*, 5, 165-173.
- Gooding, R.H. 1996. Genetic variation in arthropod vectors of disease-causing organisms: obstacles and opportunities. *Clinical Microbiology Reviews*, 9, 301-320.

- Gunn, S.J. and L.R. Hilburn. 1990. Cystosystematics of five North American *Dermacentor* (Acarina: Ixodidae) species. *Journal of Medical Entomology*, 27, 620-627.
- Hoogstraal, H. 1956. African Ixodidae I. Ticks of the Sudan (with special reference to equatorial province and with preliminary reviews of the genera *Boophilus*, *Margaropus* and *Hyalomma*). U.S. Naval Medical research Unit No. 3, Cairo.
- Huelsenbeck, J.P. and F. Ronquist. 2001. MRBAYES: Bayesian inference of phylogenetic trees. *Bioinformatics*, 17, 754-755.
- Huelsenbeck, J. P., B. Larget, R.E. Miller and F. Ronquist. 2002. Potential applications and pitfalls of Bayesian inference of phylogeny. *Systematic Biology*, 51, 673-688.
- Hunt, L.M. and L.R. Hilburn. 1985. Biochemical differentiation between species of ticks (Acari: Ixodidae). *Annals of Tropical Medicine and Parasitology*, 79, 525-532.
- Hwang, U.W. and W. Kim. 1999. General properties and phylogenetic utilities of nuclear ribosomal DNA and mitochondrial DNA commonly used in molecular systematics. *The Korean Journal of Parasitology*, 37, 215-228.
- Latif, A. A., T. Hove, G.K. Kanhai, S. Masaka and R.G. Pegram. 2001. Epidemiological observations of Zimbabwean theileriosis: disease incidence and pathogenicity in susceptible cattle during *Rhipicephalus appendiculatus* nymphal and adult seasonal activity. *Onderstepoort Journal of Veterinary Research*, 68, 187-195.
- Lawrence, J.A., R.A.I. Norval and G. Uilenberg. 1983. *Rhipicephalus appendiculatus* as a vector of bovine theileriae. *Tropical Animal Health and Production*, 15, 39-42.
- MacLeod, J. 1970. Tick infestation in the southern province of Zambia. *Bulletin of Entomological Research*, 60, 253-274.
- MacLeod, J. and M.H. Colbo. 1976. Ecological studies of ixodid ticks (Acari, Ixodidae) in Zambia I. Cattle as hosts of larvae of *Amblyomma variegatum* (F.) and *Rhipicephalus appendiculatus* (Neum.). *Bulletin of Entomological Research*, 66, 65-74.
- MacLeod, J., M.H. Colbo, M.H. Madbouly and B. Mwanaumo. 1977. Ecological studies of ixodid ticks (Acari, Ixodidae) in Zambia III. Seasonal activity and attachment sites on cattle with notes on other hosts. *Bulletin of Entomological Research*, 67, 161-173.
- MacLeod, J. and B. Mwanaumo. 1978. Ecological studies of ixodid ticks (Acari, Ixodidae) in Zambia IV. Some anomalous infestations in the northern and eastern regions. *Bulletin of Entomological Research*, 68, 409-429.
- Madder, M. and D. Berkvens. 1997. Evaluation of an *in vitro* method to measure behavioural diapause in the tick *Rhipicephalus appendiculatus* (Acarina: Ixodidae) in the laboratory. *Parasitology*, 155, 97-100.
- Madder, M., N. Speybroeck, J. Brandt and D. Berkvens. 1999. Diapause induction in adults of three *Rhipicephalus appendiculatus* stocks. *Experimental and Applied Acarology*, 23, 961-968.

- Madder, M., N. Speybroeck, J. Brandt, L. Tirry, I. Hodek and D. Berkvens. 2002. Geographic variation in diapause response of adult *Rhipicephalus appendiculatus* ticks. *Experimental and Applied Acarology*, 27, 209-221.
- Madder, M., N. Speybroeck, A. Bilounga, D. Helleputte and D. Berkvens. 2005. Survival of unfed *Rhipicephalus appendiculatus* and *Rhipicephalus zambeziensis* adults. *Medical and Veterinary Entomology*, 19, 245-250.
- Mallet, J. 2001. Species, concepts of. *In*: Levin, S. A. (ed.). *Encyclopedia of Biodiversity*, 5, pp 427-440. Academic Press, San Diego, CA.
- Masumu, J.M. 2006. Study of genetic variability of *Trypanosoma congolense* Savannah strains in an endemic trypanosomiasis focus in eastern Zambia (pp47-55). *In*: The importance of *Trypanosoma congolense* strain diversity in the epidemiology of bovine trypanosomiasis. PhD Thesis. pp118. Ghent University.
- Mayden, R.L. 1997. A hierarchy of species concepts: the denouement in the saga of the species problem (pp. 382-425). *In*: Claridge, M.F., H.A. Dawah, M.R. Wilson (Eds.), *Species; the units of biodiversity*, Chapman and Hall, London.
- Mayr, E. 1940. Speciation phenomena in birds. *The American Naturalist*, 74, 249-278.
- Mayr, E. 1982. Proceedings from the International Meeting on Mechanisms of speciation pp1-19. *In*: Barigozzi, C. (ed). *Progress in clinical and Biological Research Vol. 96*. Alan R Liss inc. New York.
- Moll, G., A. Lohding, A.S. Young, and B.L. Leitch. 1986. Epidemiology of theileriosis in calves in an endemic area of Kenya. *Veterinary Parasitology*, 19, 255-273.
- Mukhebi, A.W., B.D. Perry, and R. Kruska. 1992. Estimated economics of theileriosis control in Africa. *Preventive Veterinary Medicine*, 12, 73-85.
- Mulumba, M., N. Speybroeck, M. Billiouw, D.L. Berkvens, D.M. Geysen and J.R. Brandt. 2000. Transmission of theileriosis in the traditional farming sector in the Southern province of Zambia during 1995-1996. *Tropical Animal Health and Production*, 32, 303-314.
- Mulumba, M., N. Speybroeck, D.L. Berkvens, D.M. Geysen and J.R. Brandt. 2001. Transmission of theileriosis in the traditional farming sector in the Southern province of Zambia during 1997-1998. *Tropical Animal Health and Production*, 33, 117-125.
- Navajas, M. and B. Fenton. 2000. The application of molecular markers in the study of diversity in acarology: a review. *Experimental and Applied Acarology*, 24, 751-774.
- Nixon, K.C. and Wheeler, Q.D. 1990. An amplification of the phylogenetic species concept. *Cladistics*, 6, 211-223.
- Norval, R.A.I., J.B. Walker and J. Colborne. 1982. The ecology of *Rhipicephalus zambeziensis* and *Rhipicephalus appendiculatus* (Acarina, Ixodidae) with particular reference to Zimbabwe. *Onderstepoort Journal of Veterinary Research*, 49, 181-190.

- Norval, R.A.I., B.H. Fivaz, J.A. Lawrence and A.F. Brown. 1985. Epidemiology of tick-borne diseases of cattle in Zimbabwe III. *Theileria parva* group. *Tropical Animal Health and Production*, 17, 19-28.
- Norval, R.A.I., J.A. Lawrence, A.S. Young, B.D. Perry, T.T. Dolan and J. Scott. 1991. *Theileria parva*: influence of vector, parasite and host relationships on the epidemiology of theileriosis in southern Africa. *Parasitology*, 102, 347-356.
- Norval, R.A.I., B.D. Perry and A.S. Young. 1992a. Economic impact of theileriosis control in Africa (pp379-403). *In: The epidemiology of theileriosis in Africa*, pp 481. Academic Press, London.
- Norval, R.A.I., B.D. Perry and A.S. Young. 1992b. Epidemiological states of theileriosis (pp279-300). *In: The epidemiology of theileriosis in Africa*, pp 481. Academic Press, London.
- Nuttall G.H.F. (1913–1914) *Rhipicephalus appendiculatus*: variation in size and structure due to nutrition. *Parasitology*, 6, 195–204.
- Nuttall, G.H.F. and C. Warburton. 1916. Ticks of the Belgian Congo and the diseases they convey. *Bulletin of Entomological Research*, 6, 313-352.
- Ochanda, H., A.S. Young, C. Wells, G.F. Medley and B.D. Perry. 1996. Comparison of transmission of *Theileria parva* between different instars of *Rhipicephalus appendiculatus*. *Parasitology*, 113, 243-253.
- Ochanda, H., A.S. Young, G.F. Medley and B.D. Perry. 1998. Vector competence of 7 rhipicephalid tick stocks in transmitting 2 *Theileria parva* parasite stocks from Kenya and Zimbabwe. *Parasitology*, 116, 539-545.
- Ochanda, H. and A.S. Young. 2003a. Survival of *Theileria parva*-infected adult *Rhipicephalus appendiculatus* under laboratory and quasi-natural conditions. *Experimental and Applied Acarology*, 29, 355-365.
- Ochanda, H. A.S. Young and G.F. Medley. 2003b. Survival of *Theileria parva* in its nymphal tick vector, *Rhipicephalus appendiculatus* under laboratory and quasi-natural conditions. *Parasitology*, 126, 571-576.
- Oliver, J.H. 1983. Chromosomes, genetic variance and reproductive strategies among mites and ticks. *Bulletin of the Entomological Society of America*, 29, 8-17.
- Page, R.D.M. and E.C. Holmes. 1998. *Molecular Evolution: a phylogenetic approach*, pp348. Blackwell Publishing. Oxford, UK.
- Paine, G.D. 1982. Ticks (Acari: Ixodoidea) in Botswana. *Bulletin of Entomological Research*, 72, 1-16.
- Paoli, G. 1916. Ixodidi raccolti nella Somalia Italiana meridionale. *Redia*, 11, 269-297.
- Pegram, R.G., B.D. Perry, F.L. Musisi and B. Mwanaumo. 1986. Ecology and phenology of ticks in Zambia: seasonal dynamics on cattle. *Experimental and Applied Acarology*, 2, 25-45.
- Peng, C.T., Y.S. Chow and P.C. Lin. 1973. Esterase activity in the tropical cattle tick, *Boophilus micropus* (Acarina: Ixodidae). *Taiwan Journal of Veterinary Medicine and Animal Husbandry*, 23, 8-13.

- Perry, B.D., P. Lessard, R.A.I. Norval, K. Kundert and R. Kruska. 1990. Climate, vegetation and the distribution of *Rhipicephalus appendiculatus* in Africa. *Parasitology Today*, 6, 100-104.
- Pétavy, G., B. Moreteau, P. Gibert, J-P. Morin and J.R. David. 2001. Phenotypic plasticity of body size in *Drosophila*: effects of a daily periodicity of growth temperature in two sibling species. *Physiological Entomology*, 26, 351-361.
- Posada, D. and K.A. Crandall. 1998. Modeltest: testing the model of DNA substitution. *Bioinformatics*, 14, 817-818.
- Purnell, R.E., C.D.H. Boarer and M.A. Peirce. 1971. *Theileria parva*: comparative infection rates of adult and nymphal *Rhipicephalus appendiculatus*. *Parasitology*, 62, 349-353.
- Regan, C.T. 1926. Organic evolution. Report of the British Association for the advancement of science, 1925, 75-86.
- Ridley, M. 2004. *Evolution* (3rd Edition). Blackwell Publishing, Oxford UK.
- Shoemaker, D.D., K.G. Ross and M.L. Arnold. 1996. Genetic structure and evolution of a fire ant hybrid zone. *Evolution*, 50, 1958-1976.
- Short, N. J. and R.A.I. Norval. 1981. The seasonal activity of *Rhipicephalus appendiculatus*, Neumann 1901(Acarina: Ixodidae) in the highveld of Zimbabwe. *Journal of Parasitology*, 67, 77-84.
- Silver, J.B. and M. Renshaw. 1999. Are mosquitoes from lower latitudes smaller? *Medical and Veterinary Entomology*, 13, 219-223.
- Simon, C., F. Frati, A. Beckenbach, B. Crespi, H. Liu and P. Flook. 1994. Evolution, weighting and phylogenetic utility of mitochondrial gene sequences and a compilation of conserved polymerase chain reaction primers. *Annals of the Entomological Society of America*, 87, 651- 701.
- Simon, D. and B. Larget. 1998. Bayesian analysis in molecular biology and evolution (BAMBE), version 1.01 beta. Department of Mathematics and Computer Science, Duquesne University, Pittsburgh, Pennsylvania.
- Simpson, G.G. 1961. *Principles of animal taxonomy*. Columbia University Press. New York.
- Sokal, R. R. and T. J. Crovello. 1970. The biological species concept: a critical evaluation. *The American Naturalist*, 104, 107-123.
- Sonenshine, D.E. 1991. *Biology of ticks*, Volume I. Oxford University Press.
- Speybroeck, N., M. Madder, P. Van Den Bossche, J. Mtambo, N. Berkvens, G. Chaka, M. Mulumba, J. Brandt, L. Tirry and D. Berkvens. 2002. Distribution and phenology of ixodid ticks in southern Zambia. *Medical and Veterinary Entomology*, 16, 430-441.
- Speybroeck, N., M. Madder, H.H. Thulke, J. Mtambo, L. Tirry, G. Chaka, T. Marcotty and D. Berkvens. 2004. Variation in the tick complex *Rhipicephalus appendiculatus*/ *Rhipicephalus zambeziensis*. *Journal of Vector Ecology*, 29, 347-354.
- Speybroeck, N., P. J. Lindsey, M. Billiouw, M. Madder, J. K. Lindsey and D.L. Berkvens. 2006. Modeling diapause termination of *Rhipicephalus*



- appendiculatus* using statistical tools to detect sudden behavioral changes and time dependencies. *Environmental Ecological Statistics*, 13, 69-87.
- Spickett, A.M. and J.R. Malan. 1978. Genetic incompatibility between *Boophilus decoloratus* (Koch, 1844) and *Boophilus microplus* (Canestrini, 1888) and hybrid sterility of Australian and South African *Boophilus microplus* (Acarina: Ixodidae). *Onderstepoort Journal of Veterinary Research*, 45, 149–153.
- Strimmer, K. and A. von Haeseler. 2003. Nucleotide substitution models (pp72-86). *In: Salemi, M., Vandamme, A-M. (Eds). The phylogenetic handbook: a practical approach to DNA and protein phylogeny (pp406). Cambridge University Press, UK.*
- Stuart, A. E. and F.F. Hunter. 1998. End-products of behaviour versus behavioural characters: a phylogenetic investigation of pupal cocoon construction and form in some North American Black flies (Diptera: Simuliidae). *Systematic Entomology*, 23, 387-398.
- Sukowati, S., V. Baimai, S. Harun, Y. Dasuki, H. Andris and M. Efriwati. 1999. Isozyme evidence for three sibling species in the *Anopheles sundaicus* complex from Indonesia. *Medical and Veterinary Entomology*, 13, 408-414.
- Suzuki, D.T., A.J.F. Griffiths, J.H. Miller and R.C. Lewontin. 1986. An Introduction to Genetic Analysis, 3<sup>rd</sup> Edition. pp504-563. Freeman and Company, New York.
- Swofford, D. L. 1999. PAUP\* Phylogenetic analysis using parsimony (\* and other methods). Sinauer Associates.
- Swofford, D. L. and J. Sullivan. 2003. Phylogeny based on parsimony and other methods (pp160-206). *In: Salemi, M., Vandamme, A-M. (Eds). The phylogenetic handbook: a practical approach to DNA and protein phylogeny (pp406). Cambridge University Press, UK.*
- Tatchell, R. J. and E. Easton. 1986. Tick (Acari: Ixodidae) ecological studies in Tanzania. *Bulletin of Entomology Research*, 76, 229-246.
- Tempia, S. 1997. Comparison of the vectorial capacity of *Rhipicephalus appendiculatus* (Acari: Ixodidae) nymphs and adults originating from Eastern and Southern provinces of Zambia infected by *Theileria parva* Katete stock. ITMA MSc Thesis No. 65.
- Templeton, A. R. 1979. The unit of selection in *Drosophila mercatorium* II. Genetic revolution and the origin of coadapted genomes in parthenogenetic strains. *Genetics*, 92, 1265-1282.
- Thompson, J.D., D. G. Higgins and T.J. Gibson. 1994. CLUSTALW: improving the sensitivity of progressive multiple sequence-alignments through sequence weighting, position-specific gap penalties and weight matrix choice. *Nucleic Acids Research*, 22, 4673-4680.
- Thompson, J.D., T.J. Gibson, F. Plewniak, F. Jeanmougin and D.G. Higgins. 1997. The CLUSTALX windows interface: flexible strategies for multiple-sequence alignment aided by quality analysis tools. *Nucleic Acid Research*, 25, 4876-4882.

- Torres, E.P., D.H. Foley and J.H. Bryan. 2006. Molecular systematics of the Philippine malaria vector *Anopheles flavirostris*. *Medical and Veterinary Entomology*, 20, 44-52.
- Vandamme, A-M. 2003. Basic concepts of molecular evolution (pp1-23). *In*: Salemi, M., Vandamme, A-M. (Eds). *The phylogenetic handbook: a practical approach to DNA and protein phylogeny* (pp406). Cambridge University Press, UK.
- Van de Peer, Y. 2003. Phylogeny inference based on distance methods (pp 101-119). *In*: Salemi, M., Vandamme, A-M. (Eds). *The phylogenetic handbook: a practical approach to DNA and protein phylogeny* (pp406). Cambridge University Press, UK.
- Von Haeseler, A. and K. Strimmer. 2003. Phylogeny inference based on maximum likelihood methods (pp 137-152). *In*: Salemi, M., Vandamme, A-M. (Eds). *The phylogenetic handbook: a practical approach to DNA and protein phylogeny* (pp406). Cambridge University Press, UK.
- Walker, J.B. 1970. Notes on the common tick species in Africa, 3<sup>rd</sup> revised edition. Cooper, McDougall and Robertson (E.A) Ltd., Nairobi.
- Walker, J.B., R.A.I. Norval and M.D. Corwin. 1981. *Rhipicephalus zambeziensis* sp. nov., a new tick from eastern and southern Africa, together with a redescription of *Rhipicephalus appendiculatus* Neumann, 1901 (Acarina, Ixodidae). *Onderstepoort Journal of Veterinary Research*, 48, 87-104.
- Walker, J.B., J.E. Keirans and I.G. Horak. 2000. *The Genus Rhipicephalus* (Acari: Ixodidae): a guide to the brown ticks of the world, pp643. Cambridge.
- Wang, H., W.R. Kaufman, W.W. Cui and P.A. Nuttall. 2001. Molecular individuality and adaptation of the tick *Rhipicephalus appendiculatus* in changed feeding environments. *Medical and Veterinary Entomology*, 15, 403-412.
- Warburton, C. 1912. Notes on the genus *Rhipicephalus*, with the description of new species and the consideration of some species hitherto described. *Parasitology*, 5, 1-20.
- Watson, J.D., T.A. Baker, S.P. Bell, A. Gann, M. Levine and R. Losick. 2004a. Mutability and repair of DNA (pp235-258). *In*: *Molecular Biology of the Gene* 5<sup>th</sup> Edition pp732. Benjamin Cummings. San Francisco.
- Watson, J.D., T.A. Baker, S.P. Bell, A. Gann, M. Levine and R. Losick. 2004b. Homologous recombination at the molecular level (pp259-292). *In*: *Molecular Biology of the Gene* 5<sup>th</sup> Edition pp732. Benjamin Cummings. San Francisco.
- Wenzel, J.W. 1992. Behavioural homology and phenology. *Annual Review of Ecology and Systematics*, 23, 361-381.
- Whelan, S., P. Liò and N. Goldman. 2001. Molecular phylogenetics: state-of-the-art methods for looking into the past. *Trends in Genetics*, 17, 262-272.
- Wiley, E.O. 1978. The evolutionary species concept reconsidered. *Systematic Zoology*, 27, 17-26.
- Wiley, E.O. 1981. Remarks on Willi's species concept. *Systematic Zoology*, 30, 86-87.

- Wimberger, P.H. and A. De Quieroz. 1996. Comparing behavioural and morphological characters as indicators of phylogeny (pp206-233). *In*: Martins, E. P. (ed.). Phylogenies and the comparative method in animal behaviour. Oxford University Press.
- Wouters, G., J. Brandt and D. Berkvens. 1987. Species characterization of *Rhipicephalus appendiculatus* and *Rhipicephalus zambeziensis* (Ixodidae: Acarina) by enzyme electrophoresis. *Annales de la Société belge de médecine tropicale*, 67, 267-270.
- Wouters, G. 1989. Hybridization model for *Rhipicephalus appendiculatus* and *R. zambeziensis* by glucose-p-isomerase isoenzymes. *Onderstepoort Journal of Veterinary Research*, 56, 235-238.
- Yang, Z. 1997. PAML: a program package for phylogenetic analysis by maximum likelihood. *Computer Applications in Biosciences*, 13, 555-556.
- Yang, Z. and B. Rannala. 2005. Branch-length prior influences Bayesian probability of phylogeny. *Systematic Biology*, 54, 455-470.
- Yeoman, G.H. 1966. Field vector studies of epizootic East Coast fever II. Seasonal studies of *Rhipicephalus appendiculatus* on bovine and non-bovine hosts in East Coast fever enzootic, epizootic and free areas. *Bulletin of Epizootic Diseases*, 15, 89-113.
- Yeoman, G.H. and J.B. Walker. 1967. The Ixodid ticks of Tanzania. Commonwealth Institute of Entomology, London, pp215.
- Young, A.S. 1981. The epidemiology of theileriosis in East Africa (pp60-62). *In*: Irvin, A.D., M.P. Cunningham and A.S. Young (Eds.). Advances in the control of theileriosis. Martinus Nijhoff, The Hague.
- Young, A.S., B.L. Leitch, R.M. Newson and M.P. Cunningham. 1984. Some factors controlling the stimulation of sporogony of *Theileria parva* in its tick vector *Rhipicephalus appendiculatus*. *International Journal for Parasitology*, 14, 97-102.
- Zahler, M, R. Gothe and H. Rinder. 1995. Genetic evidence against a morphologically suggestive conspecificity of *Dermacentor reticulatus* and *D. marginatus* (Acari: Ixodidae). *International Journal for Parasitology*, 25, 1413-1419.
- Zahler, M., N.A. Filipova, P.C. Morrel, R. Gothe, H. Rinder. 1997. Relationships between species of *Rhipicephalus sanguineus* group: a molecular approach. *Journal of Parasitology*, 83, 302-306.
- Zivkovic, D., R.G. Pegram, F. Jongejan and E.T. Mwase. 1986. The biology of *Rhipicephalus appendiculatus* and *R. zambeziensis* and production of a fertile hybrid under laboratory conditions. *Experimental and Applied Acarology*, 2, 285-298.
- Zumpt, F. 1942. *Rhipicephalus appendiculatus* Neum. Und verwandte Arten.VI. Vorstudie zu einer Revision der Gattung *Rhipicephalus* Koch. *Zeitschrift für Parasitenkunde*, 12, 538-551.



## **Chapter 3 - OBJECTIVES OF THE STUDY**

### 3.1 Introduction

The vectors of the causative organism of East Coast fever (ECF), the tick species *Rhipicephalus appendiculatus* and *R. zambeziensis* have long been known to show subtle morphological differences. This led to the use of terms such as “*R. appendiculatus* type II” (Yeoman and Walker, 1967), or “heavily punctate specimens near *R. appendiculatus*” (MacLeod, 1970) when referring to *R. zambeziensis*. The two taxa also differ in their vectorial capacity (Tempia, 1997; Mulumba *et al.*, 2000) and their phenologies (Berkvens *et al.*, 1998; Madder *et al.*, 1999; Speybroeck *et al.*, 2002). As a consequence Walker *et al.* (1981) concluded that the two taxa are different species. However, the species status of *R. appendiculatus* and *R. zambeziensis* has again been questioned in the recent past by Speybroeck *et al.* (2002) and Madder *et al.* (2005) because *R. appendiculatus* from lower altitudes on the plateau of the Eastern province is morphologically indistinguishable from *R. zambeziensis* (Berkvens *et al.*, 1998). In addition, *R. appendiculatus*, *R. zambeziensis* and their morphological intermediates live microsympatrically (up to on the same individual host) in the Southern province.

Furthermore, the epidemiology of ECF in the Eastern and Southern province is different. In the Eastern province the epidemiology has been described as being in the state of ‘first level endemically stable’, while in the Southern province it has been described as ‘epidemic’ (Billiouw, 2005). This difference has mainly been attributed to the putative differences in the taxonomic composition and the ecology of the *R. appendiculatus* stocks in the two provinces (Billiouw *et al.*, 1999; Speybroeck *et al.*, 2004).

Since on the one hand the differences in the stock and taxonomic composition of *R. appendiculatus* have been suggested to be responsible for the epidemiological differences of ECF within and between the two provinces, while on the other hand the specific status of *R. appendiculatus* and *R. zambeziensis* has been questioned, it is important to resolve the taxonomy of the *R. appendiculatus* complex. In order to do so, it is essential to make an in-depth analysis of phenotypic and molecular variation within and between populations comprising the alleged taxa in the relevant geographic areas (Zahler *et al.*, 1995, 1997), hence our general objective.

### **3.2 General objectives**

To describe intra- and inter-population variation within and between *R. appendiculatus* and *R. zambeziensis* with the aim of improving our taxonomic understanding of this species complex and to assess how this variation may be affecting the epidemiology of East Coast fever.

### **3.3 Specific objectives**

The following were the specific objectives of this study

1. Describe phenotypic and genetic variation within and between *R. appendiculatus* and *R. zambeziensis* and use phylogenetic methods to assess how far both species and constituent stocks represent monophyletic units.
2. Compare methods of preserving tick material for DNA extraction for use in PCR techniques.
3. Develop a molecular tool for the identification of *R. appendiculatus* and *R. zambeziensis*.

### 3.4 References

- Berkvens, D.L., D.M. Geysen, G. Chaka, M. Madder and J.R.A. Brandt 1998. A study of ixodid ticks parasitizing cattle in the Eastern Province of Zambia. *Medical and Veterinary Entomology*, 12, 234-240.
- Billiouw, M., L. Mataa, T. Marcotty, G. Chaka, J. Brandt and D. Berkvens. 1999. The current epidemiological status of bovine theileriosis in eastern Zambia. *Tropical Medicine and International Health*, 4, A28-A33.
- Billouw, M. 2005. Analysis of the transmission dynamics of *Theileria parva* (pp85-105). *In: The epidemiology of bovine theileriosis in the Eastern province of Zambia*. PhD thesis.
- MacLeod, J. 1970. Tick infestation in the southern province of Zambia. *Bulletin of Entomological Research*, 60, 253-274.
- Madder, M., N. Speybroeck, J. Brandt and D. Berkvens. 1999. Diapause induction in adults of three *Rhipicephalus appendiculatus* stocks. *Experimental and Applied Acarology*, 23, 961-968.
- Madder, M., N. Speybroeck, A. Bilounga, D. Helleputte and D. Berkvens. 2005. Survival of unfed *Rhipicephalus appendiculatus* and *Rhipicephalus zambeziensis* adults. *Medical and Veterinary Entomology*, 19, 245-250.
- Mulumba, M., N. Speybroeck, M. Billiouw, D.L. Berkvens, D.M. Geysen and J.R. Brandt. 2000. Transmission of *Theileria parva* in the traditional farming sector in the Southern province of Zambia during 1995-96. *Tropical Animal Health and Production*, 32, 303-314.
- Speybroeck, N., M. Madder, P. Van Den Bossche, J. Mtambo, N. Berkvens, G. Chaka, M. Mulumba, J. Brandt, L. Tirry and D. Berkvens. 2002. Distribution and phenology of ixodid ticks in southern Zambia. *Medical and Veterinary Entomology*, 16, 430-441.
- Speybroeck, N., M. Madder, H.H. Thulke, J. Mtambo, L. Tirry G. Chaka, T. Marcotty and D. Berkvens. 2004. Variation in body size in the tick complex *Rhipicephalus appendiculatus/Rhipicephalus zambeziensis*. *Journal of Vector Ecology*, 29, 347-354.
- Tempia, S. 1997. Comparison of the vectorial capacity of *Rhipicephalus appendiculatus* (Acari: Ixodidae) nymphs and adults originating from Eastern and Southern provinces of Zambia infected by *Theileria parva* Katete stock. ITMA MSc Thesis No.65.
- Walker, J.B., R.A.I. Norval and M.D. Corwin. 1981. *Rhipicephalus zambeziensis* sp. nov., a new tick from eastern and southern Africa, together with a redescription of *Rhipicephalus appendiculatus* Neumann, 1901 (Acarina, Ixodidae). *Onderstepoort Journal of Veterinary Research*, 48, 87-104.
- Yeoman, G.H. and J.B. Walker. 1967. The Ixodid ticks of Tanzania. Commonwealth Institute of Entomology, London, pp215.
- Zahler, M, R. Gothe and H. Rinder. 1995. Genetic evidence against a morphologically suggestive conspecificity of *Dermacentor reticulatus* and *D. marginatus* (Acari: Ixodidae). *International Journal for Parasitology*, 25, 1413-1419.



Zahler, M., N.A. Filipova, P.C. Morrel, R. Gothe, H. Rinder. 1997. Relationships between species of *Rhipicephalus sanguineus* group: a molecular approach. *Journal of Parasitology*, 83, 302-306.



**Chapter 4 - PHENOTYPIC COMPARISON OF THREE  
RHIPICEPHALID TICK STOCKS FROM ZAMBIA**

## 4.1 Introduction

The Rhipicephalid ticks *Rhipicephalus appendiculatus* Neumann 1907 and *Rhipicephalus zambeziensis* Walker, Norval, Corwin 1981 have been identified as the most important vector species of the haemoprotist (Adl *et al.*, 2005) *Theileria parva* the causative agent of East Coast fever (Norval *et al.*, 1992; Ochanda *et al.*, 1998).

*Rhipicephalus appendiculatus* has been reported in 17 countries in eastern, central and southern Africa. It is found at altitudes of just above sea level to 2000m, with annual rainfall ranging between 500 to 2000mm (Walker *et al.*, 2000). *Rhipicephalus appendiculatus* has been reported throughout Zambia (Akafekwa, 1976; Pegram *et al.*, 1986). Infestation levels vary with areas (MacLeod and Mwanaumo, 1978).

*Rhipicephalus zambeziensis*, a species morphologically closely related to *R. appendiculatus*, has been reported from Tanzania southwards to parts of Zambia, Angola, Namibia, Botswana, Mozambique and South Africa (Walker *et al.*, 2000). This species is, as a rule, is less widely distributed and found at lower altitudes in hotter and drier areas than *R. appendiculatus*.

The earliest reports of *R. zambeziensis* (then referred to as “specimens near *R. appendiculatus*”) in Zambia were in the valleys of the Zambezi and Luangwa rivers (MacLeod, 1970; MacLeod *et al.*, 1977). The species has since been reported in areas outside the valleys (Zivkovic *et al.*, 1986; Speybroeck *et al.*, 2002; Mtambo *et al.*, 2007a).

A substantial amount of data on the ecology of *R. appendiculatus* and *R. zambeziensis* has accumulated in Zambia in general (Akafekwa, 1976; MacLeod *et al.*, 1977; MacLeod and Mwanaumo, 1978; Pegram *et al.*, 1986; Pegram and Banda, 1990; Zieger *et al.*, 1998) and Eastern province and Southern province in particular (MacLeod, 1970; Berkvens *et al.*, 1995, 1998; Tempia, 1997; Mulumba, 1999; Chaka *et al.*, 1999; Speybroeck *et al.*, 2002; Mtambo *et al.*, 2007b). In the Eastern and Southern provinces the huge efforts of the Belgian funded project Assistance to the Veterinary Services of Zambia (ASVEZA) and its forerunner the Belgium Animal Diseases Control project (BADCP) has contributed greatly to this wealth of ecological information.

Despite this it is still not clear the species status and distribution of *R. appendiculatus* and *R. zambeziensis* in the two provinces. The species status has been questioned mainly due to the microsympatric occurrence of *R. appendiculatus* and *R. zambeziensis* in Southern province (Speybroeck *et al.*, 2002; Madder *et al.*, 2005). The latter problem arises because *R. appendiculatus* in Eastern province include a high proportion of morphologically *R. zambeziensis*-like specimens especially at lower altitudes on the plateau area (Berkvens *et al.*, 1998). In addition there are conflicting reports on the presence (MacLeod and Mwanaumo, 1978; Norval *et al.*, 1982) or otherwise (Berkvens *et al.*, 1998) of *R. zambeziensis* in the province. This is compounded by the fact that adults of *R. appendiculatus* and *R. zambeziensis* s.s. are morphologically difficult to discriminate.

Meanwhile, Mulumba (1999), Speybroeck *et al.* (2002) and Billiouw (2005) have described different vector effects on the transmission patterns of *Theileriosis* in both provinces. In addition, the epidemiology of ECF in the two provinces is different (Billiouw *et al.*, 1999; Speybroeck *et al.*, 2002; Billiouw, 2005).

In this study we compared the phenotypes of three stocks of *Rhipicephalus* spp. Phenotypes refer to any observable or measurable character of an organism e.g. morphological, behavioural and phenology including those that hard to measure or observe (Ridley, 2004). The three stocks were Wafa (Chipata-Eastern province), Nkonkola (Mazabuka-Southern province) and Keemba an *R. zambeziensis* stock (Monze-Southern province) in Zambia. The phenotypes compared included morphological characteristics of size and shape and some aspects of their life cycle.

The aim of the study was to describe and compare phenotypic variation within and between the stocks. The differences in the phenotypes (morphology and life cycle traits) might be helpful in their identification and explanation of their different roles in the epidemiology of ECF.

## **4.2 Materials and Methods**

### **4.2.1 Tick stocks**

Five stocks of ticks were used in the comparison of morphological characters. All the five were third generation laboratory maintained stocks using standard tick breeding protocols (all engorged instars were kept in an incubator at  $26 \pm 1$  °C and 85% RH) at the Institute of Tropical Medicine, Antwerp (ITMA). After moulting, instars were

maintained at  $22 \pm 1^\circ\text{C}$  and 85% RH. All instars were fed on New Zealand white rabbits. Each rabbit was only used once. The five stocks were: (1) *R. zambeziensis* stock from Keemba, Southern province-Zambia (RzKb); (2) *R. zambeziensis* from South Africa (RzSA); (3) *R. appendiculatus* from Nkonkola, Southern province Zambia (RaNk), (4) *R. appendiculatus* from Wafa, Eastern province-Zambia (RaWa) and; (5) *R. appendiculatus* from SA (OVI) RaSA. The two stocks from South Africa i.e. RaSA and RzSA were used as reference (control) specimens in the comparisons of the considered morphological or characters.

#### **4.2.2 Morphological identification, Scoring and Measurements**

Morphological identification of three test sample stocks was done by means of a stereo microscope (Zeiss stemi 2000) using the identification keys of Walker *et al.* (2000). Scoring of morphological characteristics was equally done under the stereo microscope. Punctuation was scored on a scale of 1-3 i.e. heavy punctuation was scored as 1, medium as 2 and mild as 3. The female genital aperture shape was scored as 1 if it had a predominantly U-shape, 2 if it was intermediate between U and V and 3 if it was V-shaped. Measurements were taken with an ocular micrometer (Wild 15xSK, Germany [ $\pm 0.0033\text{mm}$ ]) mounted onto a stereo microscope. This was done on 100 individuals (50 males and 50 females) of each of the five colony stocks. Measurements of the length and width of the conscutum, length and width of spiracles and length and width of adanal plates in male specimens were done. In female specimens the length and width of the scutum and length and width of spiracles were measured.

#### **4.2.3 Life cycle traits**

The following life cycle traits were compared for the three sample stocks from Zambia that is Wafa, Nkonkola and Keemba. (1) Duration of engorgement of adults (2) Pre-oviposition period (3) Period to hatching of their eggs (4) Duration to engorgement of larvae (5) Period to moulting of larvae (6) Duration to engorgement of nymphs and; (7) Period to moulting of nymphs.

#### **4.2.4 Statistical analysis**

Morphological comparisons were done with the Kruskal-Wallis test in the program Stata 8 (StataCorp., 2003). Life cycle traits were analyzed using Survival analysis in Stata 8 (StataCorp., 2003).

### 4.3 Results

The results of the measurements are presented in figures 4.1 and 4.2 for males and females, respectively.

In males, RaNk had the longest and widest conscutum followed by RaSA, then RaWa. The differences in the conscutal lengths and widths of RaNk and RaSA were significant ( $\chi^2=23.167$ ;  $p=0.0001$ ;  $df=1$  and  $\chi^2=12.950$ ;  $p=0.0003$ ;  $df=1$  for conscutum length and width respectively). There were no significant differences between the conscutal lengths and widths of RzKb and RzSA.

RaNk had the longest mean adanal plate length, followed by RaSA and RaWa. The difference between RaNk and RaSA adanal plate length was significant ( $\chi^2=29.545$ ;  $p=0.0001$ ;  $df=1$ ). RaSA and RaWa adanal plate lengths were not significantly different and so were the adanal plate lengths of the RzKb/RzSA pair. The mean adanal plate width was widest in RaSA followed by RaNk then a cluster of RaWa RzKb and RzSA. The RaSA/RaNk adanal plate width was significantly different ( $\chi^2=22.674$ ;  $p=0.0001$ ;  $df=1$ ). There was no significant difference in the adanal plate widths of the RaWa RzKb and RzSA cluster. RzSA adanal plate ratio was intermediate between the RzKb/RaNk/RaWa cluster and RaSA which was the least.

RaSA had the longest spiracle length followed by RaNk and RaWa. The difference in spiracle length between RaSA and RaNk was not significant. RzKb had the least spiracle length that was not significantly different from that of RzSA. There was no significant difference in spiracle width of RaSA and RaNk. RzKb had the shortest spiracle width followed by RaWa. The two were significantly smaller than RzSA ( $\chi^2=22.841$ ;  $p=0.0001$ ;  $df=1$ ).

RzSA had the least spiracle ratio while RaWa the biggest. The spiracle ratios of RaSA and RaNk were intermediate between RzKb and RzSA and there was no significant difference between the ratios of the former pair. The difference in spiracle ratio between RzSA and RzKb was significant ( $\chi^2=16.597$ ;  $p=0.0001$ ;  $df=1$ ).

RaSA was the least punctate followed by RaNk then RaWa. There was no significant difference in punctuation within this cluster. The RaSA /RaNk/RaWa cluster was significantly less punctate ( $\chi^2=75.96$ ;  $p=0.0001$ ;  $df=1$ ) than Rzkb/RzSA within which there was no significant difference.

In females, RaSA had the longest scutum length followed by RaNk. RzSA was the shortest but one, with RzKb as the shortest. There was no significant difference in scutal length between RaWa and RzSA. There was a significant difference between RzKb and RzSA scutum lengths ( $\chi^2=6.758$ ;  $p=0.0093$ ;  $df=1$ ) (fig.4.2).

The RaSA stock had the widest mean scutal width, followed by RaNk, then RaWa. RzSA had the narrowest but one scutal width, with RzKb the narrowest. There was a significant difference between RaSA and RaNk in scutal width ( $\chi^2=13.099$ ;  $p=0.0003$ ;  $df=1$ ) and between RzSA and RzKb ( $\chi^2=13.448$ ;  $p=0.0002$ ;  $df=1$ ). There was no significant difference between RaWa and RzSA (fig.4.2).

The spiracle length was longest in RaSA, followed by RaNk, then RaWa. The shortest spiracle length was recorded in RzSA followed by RzKb. The difference between RaSA and RaNk spiracle lengths was significant ( $\chi^2=6.865$ ;  $p=0.0088$ ;  $df=1$ ) and so was that between RzKb and RzSA ( $\chi^2=5.885$ ;  $p=0.0153$ ;  $df=1$ ). RaNk, RaSA, and RaWa had similar (significantly not different) mean spiracle widths. There was a significant difference between this cluster and the RzSA and RzKb cluster. There was a significant difference between RzSA and RzKb ( $\chi^2=6.319$ ;  $p=0.0119$ ;  $df=1$ ). The spiracle ratio was biggest in RzKb and smallest in RzSA. RaNk, RaSA and RaWa presented with intermediate ratios. There was a significant difference between the RzKb and RzSA spiracle ratios ( $\chi^2=19.661$ ;  $p=0.0001$ ;  $df=1$ ).

Punctuation was lightest in RaSA followed by RaNk. The difference in punctuation between these two was significant ( $\chi^2 =12.288$ ;  $p=0.0005$ ;  $df=1$ ) RzKb, RzSA, and RaWA formed a cluster on the heavy punctuation side of the graph with RzSA as the most punctate. The difference in punctuation between the RzKb and RzSA was significant ( $\chi^2=4.591$ ;  $p=0.0321$ ;  $df=1$ ).

RaSA had the most pronounced V-form of the female genital aperture followed by RaNk. The difference between these two stocks was not significant. RzSA had the most pronounced U-form of the genital structure. There was a significant difference between the form of the genital aperture of RzKb and RzSA ( $\chi^2=27.466$ ;  $p=0.0001$ ;  $df=1$ ).



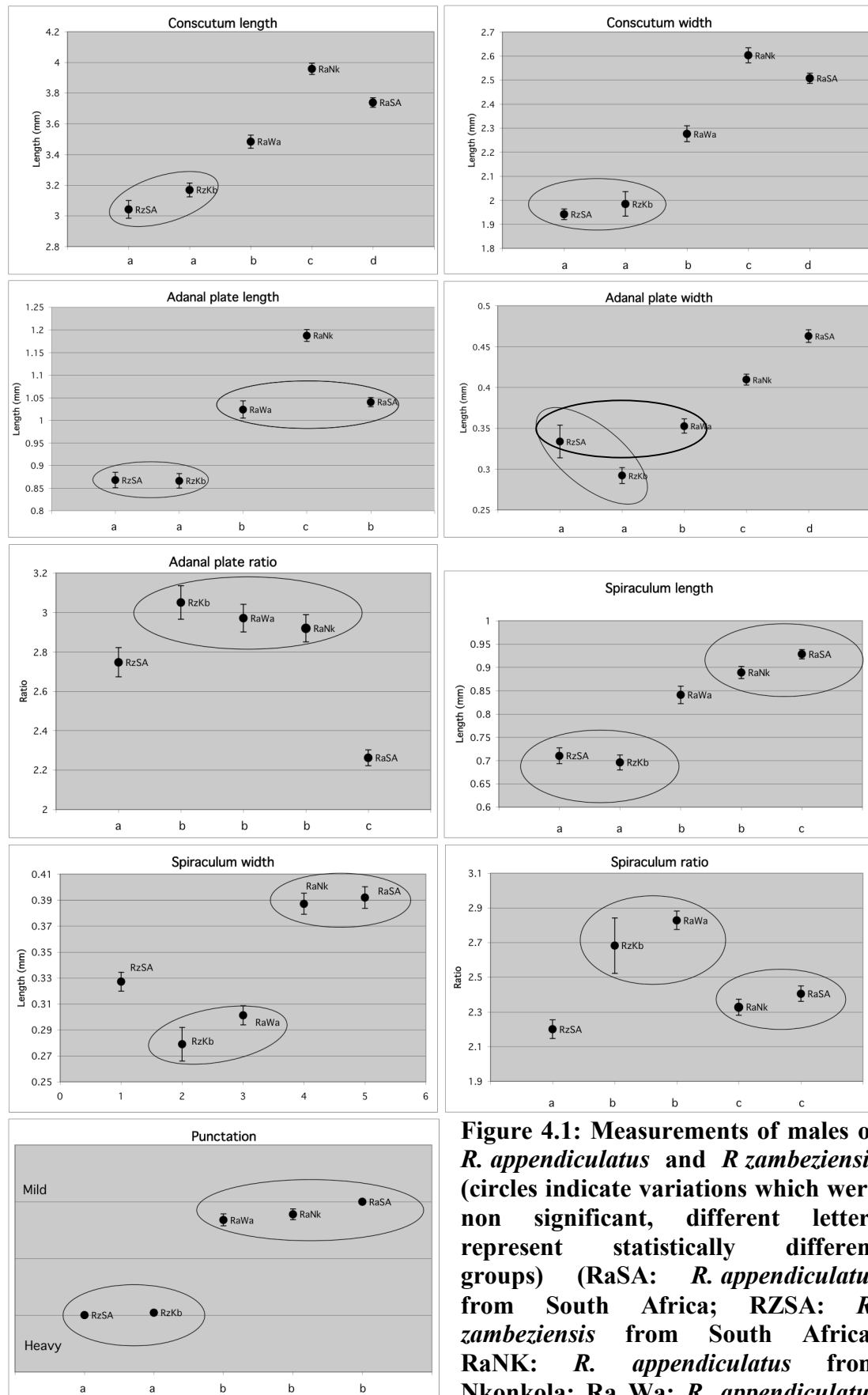

**Figure 4.1: Measurements of males of *R. appendiculatus* and *R. zambeziensis* (circles indicate variations which were non significant, different letters represent statistically different groups) (RaSA: *R. appendiculatus* from South Africa; RZSA: *R. zambeziensis* from South Africa; RaNK: *R. appendiculatus* from Nkonkola; Ra Wa: *R. appendiculatus* from Wafa; RzKb: *R. zambeziensis* from Keemba)**

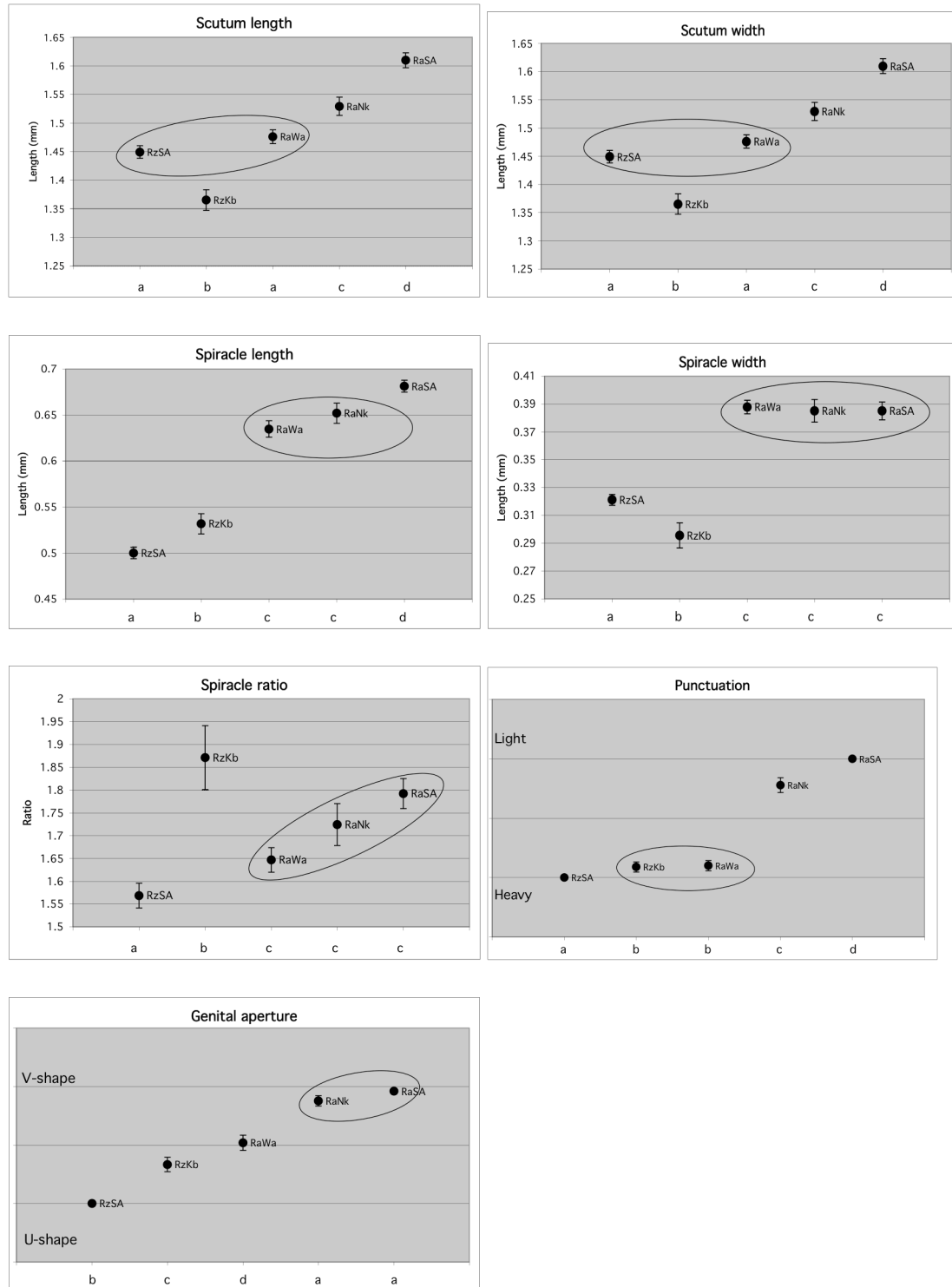

**Figure 4.2: Measurements of females of *R. appendiculatus* and *R. zambeziensis* (circles indicate variations which were non significant, different letters represent statistically different groups) (RaSA: *R. appendiculatus* from South Africa; RzSA: *R. zambeziensis* from South Africa; RaNk: *R. appendiculatus* from Nkonkola; RaWa: *R. appendiculatus* from Wafa; RzKb: *R. zambeziensis* from Keemba)**

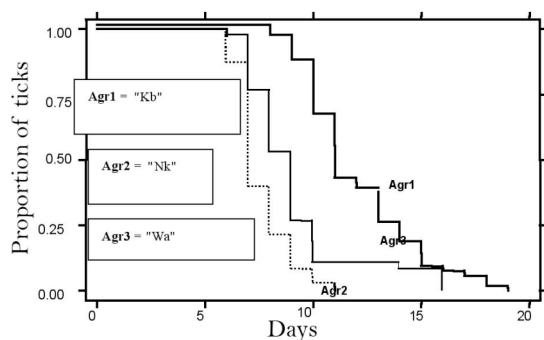

Figure 4.3: Engorgement females

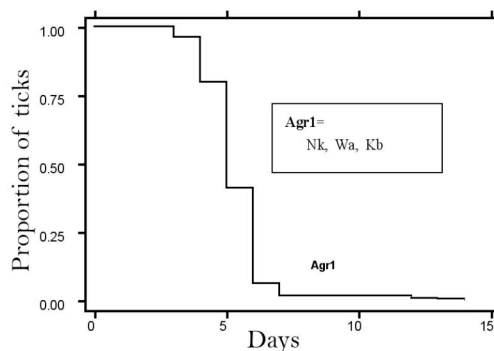

Figure 4.4: Pre-oviposition

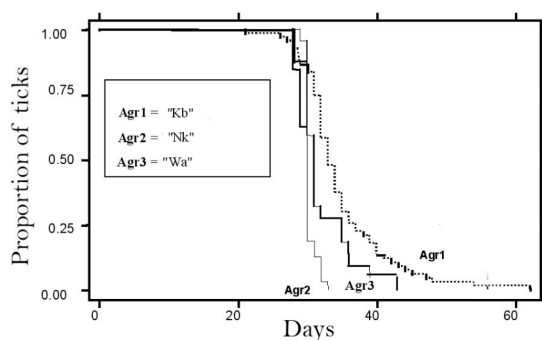

Figure 4.5: Eclosion eggs

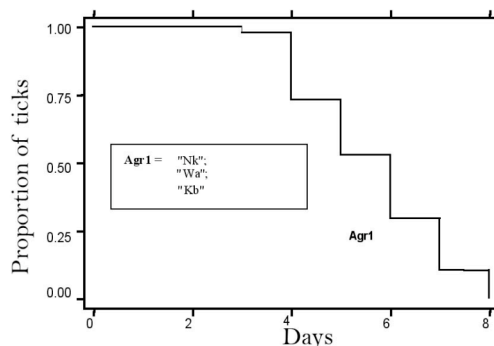

Figure 4.6: Engorgement larvae

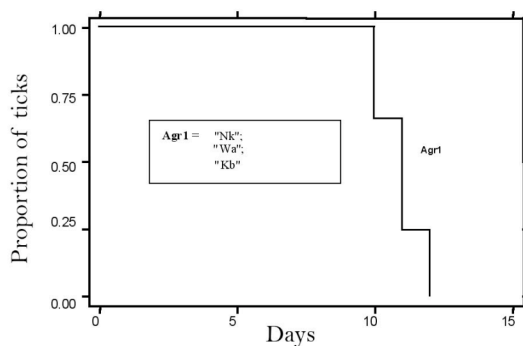

Figure 4.7: Moulting larvae

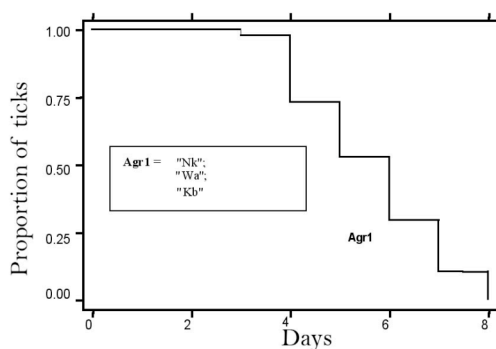

Figure 4.8: Engorgement nymphs

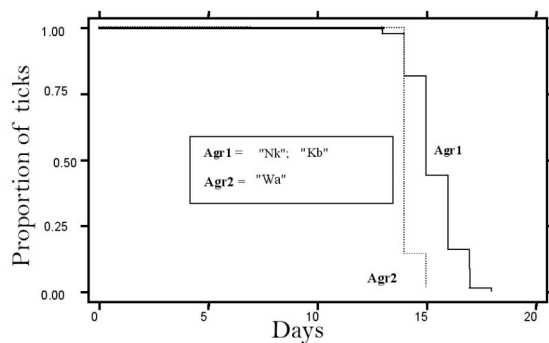

Figure 4.9: Moulting nymphs

Figure 4.3 – 4.9: *R. appendiculatus* stocks used: Wa = from Wafa; Nk = Nkonkola; *R. zambeziensis* stock used: Kb = Keemba.

Results of the comparison of life cycle traits are presented in figure 4.3 – 4.9.

Briefly, females of Keemba took the longest to complete their engorgement (approximately 19 days, followed by Wafa (16 days) and least was Nkonkola at 12 days. The pre-oviposition period was the same for all the stocks.

Nkonkola had the shortest hatching period with over 75% of the eggs hatched by day 30. Keemba took the longest with only about 50% of the eggs hatched by day 30 and eclosion was not complete by day 60.

Larvae engorgement was the same for all the three stocks, over 75% of the ticks engorged by day 6 and completed by day 7. No difference was observed in duration of larval moult. Nymphs of the three showed no difference in duration of engorgement that was completed by day 8. The nymph moult showed two groups. The longer profile was for Keemba, Nkonkola and some proportion of the Wafa ticks that completed their moult by day 18. The second was a proportion of Wafa ticks that completed their moult by day 15.

#### **4.4 Discussion**

Scutal length has been used as a size index in *R. appendiculatus* (Chaka, 2001). Based on scutal length males of the Nkonkola stock (RaNk) were the biggest ticks. This agrees with Speybroeck *et al.* (2004) who found the RaNk to be the biggest of seven *R. appendiculatus* and *R. zambeziensis* stocks drawn from Kenya, Zambia, Zimbabwe and South Africa. This observation is counter to the general observed pattern of ectotherms being larger with increased latitude (Silver and Renshaw, 1999), going by which case RaSA should have been the biggest. There were no significant differences in the conscutum length and width of males of RzKb and RzSA and by implication no difference in size between these two stocks. These findings are consistent with those of Speybroeck *et al.* (2004) who did not find a significant difference in size between males of *R. zambeziensis* from Zambia, Zimbabwe and South Africa.

There was very little variation between males of RzKb and the control stock RzSA as seven parameters measured presented no significant variation between the two except the two ratios. This was however, not the case in the two *R. appendiculatus* stocks (RaWa and RaNk) and the control stock (RaSA). This indicates more variation in these tick stocks as only one parameter, punctuation was significantly not different in all the three stocks.

In the females, RaSA were the largest stock, thus unlike the males, this group obeyed the rule of increased size with latitude.

The females of the tick stock RzKb and the control stock RzSA were significantly different in all the morphological features considered. This might indicate that female specimens of *R. zambeziensis* unlike the males might be more variable morphologically. RaWa females had scutal length and width not significantly different from RzSA which agrees with its description as a small stock (Speybroeck *et al.*, 2004) since RzSA is also a small stock. The punctuation of the females of RaWa was not significantly different from RzKb. Therefore apart from size, RaWa was also not significantly different in punctuation to RzKb which might make their identification difficult as these two features are very useful in differentiating *R. appendiculatus* and *R. zambeziensis* in general. The mean genital aperture form of RaWa was intermediate between the V- and U-forms. This is yet another feature that is often used to identify *R. appendiculatus* and *R. zambeziensis*. The significant differences in all the morphological features, except for spiracle width, in the control tick stocks and the test stocks might be an indicator of the potential difficulties of morphological discrimination of the females of these tick stocks.

*Rhipicephalus zambeziensis* has been reported to have a longer generation cycle than *R. appendiculatus*. The extended engorgement and eclosion periods of Keemba stock observed is consistent with that observation.

The eclosion profile of the Keemba stock was very fascinating. Eclosion of the eggs started the earliest (ca.10 days earlier), but completed eclosion ca.30 days later than the stock that completed eclosion the earliest. The other interesting aspect was that a very small proportion of eggs hatched at every step. This “miserly hatching” profile might contribute to the tick spreading its larvae over a long period (>60 days). This period may be longer in the wild because of variable environmental conditions. This slow eclosion and the slow engorging period of adults might be the major risk spreading mechanisms this tick may have, in the absence of diapause. However, eggs are very vulnerable. The question of how these eggs survive the extreme climatic conditions of the areas in which *R. zambeziensis* is found still remains.

Nkonkola had the shortest adult engorgement and egg eclosion period. Compared to the other two stocks, Nkonkola should have the shortest generation period. This is not

the case in nature, however, because stocks of *R. appendiculatus* from Southern province undergo a diapause (Berkvens *et al.*, 1995; Madder *et al.*, 1999, 2002). It looks like immediately this tick commits itself to feeding (when cues predicting favourable conditions have been read) it hastens all stages of the cycle that can be tuned to reach the safest instar, i.e. the adult stage. It might also be a strategy purely to shorten the cycle, being “conscious” of a long diapause ahead since the more viable offspring an individual contributes to next generation determines their fitness.

The nymphal moult was the same for all the three stocks. However, there was a cohort of Wafa nymphs that had an accelerated moult. The existence of two ecological groups in Eastern province stocks has been reported. For instance Chaka *et al.* (1999) observed two groups on adult body size. A small adult body size group that fed earlier in the rainy season and a large adult body size group. Madder *et al.* (2002) observed mixed response to diapause initiation and termination. The Wafa cohort that fed quickly may be the diapausing phenotype “rushing to reach the safe adult stage whilst the group that completed the nymphal moult later could be the non diapausing phenotypes. However, these assumptions cannot be substantiated with the current data.

It seems life cycle control mechanisms of averting risk are invested in some selected stages of the cycle. Such mechanisms might be absent in the larval stage hence all the three stocks showed almost identical profiles for engorgement and moulting. The adult stage control mechanisms may be modulated by delayed feeding (diapause or quiescence that were not studied in this work) and a varied engorgement period of individuals of a cohort. Eggs may modulate the life cycle possibly by varying their development or eclosion or both. This may be genetically predetermined or is triggered by environmental cues or an interaction of the two.

In conclusion we have observed that RaNk is the largest and least punctate of the three Zambian test stocks. RzKb was the smallest of the three. RzKb and RaWa may be confused especially in female specimens due to a lack of differentiation between the two especially with respect to size and punctation. The form of the female genital aperture might not be discrete, but continuous ranging from the most V-form through to the most U-form. In all stocks the females showed more morphological variation than the males. We therefore conclude that morphological variations or differences might pose difficulties in differentiating the three stocks

Nkonkola had the shortest adult feeding to nymphal moult part of the life cycle. And we speculate that the modulation of this part of the cycle is likely to be invested in the feeding of the adults and egg eclosion. The Keemba life cycle was characterised by the “dribs and drabs” engorgement of the adults and eclosion of eggs. Without the demonstration of diapause phenomenon in ticks of the *R. zambeziensis* type, this may be the major point of modulation of this tick’s life cycle.

The RaWa group showed an intermediate adult engorgement period between Keemba and Nkonkola stocks. Apart from adult engorgement and egg eclosion stages this tick seems to have an added mechanism of control invested in the nymphal moult. At the nymphal moult, one group of Wafa stock moulted very quickly (ca.14 days) and the second group took longer (ca.18days). This dichotomy is consistent with the observed spatial and temporal variation in *R. appendiculatus* from Eastern province (Chaka *et al.*, 1999). The life cycle traits of the three stocks did offer some grounds on which speculation on the differences in the epidemiology of ECF in their areas can be based. Finally the phenotypes taken together could differentiate the three stocks.

## 4.5 References

- Adl, S.M., A.G.B. Simpson, M.A. Farmer, R.A. Andersen, O.R. Anderson, J.R. Barta, S.S. Bowser, G. Brugerolle, R.A. Fensome, S. Fredericq, T.Y. James, S. Karpov, P. Kugrens, J. Krug, C.E. Lane, L.A. Lewis, J. Lodge, D.H. Lynn, D.G. Mann, R.M. McCourt, L. Mendoza, Ø. Moestrup, S.E. Mozley-Standridge, T.A. Nerad, C.A. Shearer, A.V. Smirnov, F.W. Spiegel and M.F.J.R. Taylor. 2005. The new higher level classification of eukaryotes with emphasis on the taxonomy of protists. *Journal of Eukaryote Microbiology*, 52, 399-451.
- Akafekwa, G. 1976. Control of tick-borne diseases in Zambia with special emphasis on East Coast fever. *Bulletin de l'Office International des Epizooties*, 86, 105-116.
- Berkvens, D.L., R.G. Pegram and J.R.A. Brandt. 1995. A study of the diapausing behaviour of *Rhipicephalus appendiculatus* and *R. zambeziensis* under quasi-natural conditions in Zambia. *Medical and Veterinary Entomology*, 9, 307-315.
- Berkvens, D.L., D.M. Geysen, G. Chaka, M. Madder and J.R.A. Brandt. 1998. A study of ixodid ticks parasitizing cattle in the Eastern Province of Zambia. *Medical and Veterinary Entomology*, 12, 234-240.
- Billiouw, M., L. Mataa, T. Marcotty, G. Chaka, J. Brandt and D. Berkvens. 1999. The current epidemiological status of bovine theileriosis in eastern Zambia. *Tropical Medicine and International Health*, 4, A28-A33.
- Billouw, M. 2005. Analysis of the transmission dynamics of *Theileria parva* (pp85-105). *In: The epidemiology of bovine theileriosis in the Eastern province of Zambia*. PhD thesis.
- Chaka, G., M. Billiouw, D.M. Geysen and D.L. Berkvens. 1999. Spatial and temporal variation in *Rhipicephalus appendiculatus* size in eastern Zambia. *Tropical Medicine and International Health*, 4, A43-A48.
- Chaka, G. 2001. Eco-physiology of *Rhipicephalus appendiculatus* (Acari: Ixodidae) in Eastern Zambia. PhD thesis No. 12. Institute of Tropical Medicine, Antwerp, Belgium.
- MacLeod, J. 1970. Tick infestation in the southern province of Zambia. *Bulletin of Entomological Research*, 60, 253-274.
- MacLeod, J., M.H. Colbo, M.H. Madbouly and B. Mwanaumo. 1977. Ecological studies of ixodid ticks (Acari, Ixodidae) in Zambia III. Seasonal activity and attachment sites on cattle with notes on other hosts. *Bulletin of Entomological Research*, 67, 161-173.
- MacLeod, J. and B. Mwanaumo. 1978. Ecological studies of ixodid ticks (Acari, Ixodidae) in Zambia IV. Some anomalous infestations in the northern and eastern regions. *Bulletin of Entomological Research*, 68, 409-429.
- Madder, M., N. Speybroeck, J. Brandt and D. Berkvens. 1999. Diapause induction in adults of three *Rhipicephalus appendiculatus* stocks. *Experimental and Applied Acarology*, 23, 961-968.



- Madder, M., N. Speybroeck, J. Brandt, L. Tirry, I. Hodek, and D. Berkvens. 2002. Geographic variation in diapause response of adult *Rhipicephalus appendiculatus* ticks. *Experimental and Applied Acarology*, 27, 209-221.
- Madder, M., N. Speybroeck, A. Bilounga, D. Helleputte and D. Berkvens. 2005. Survival of unfed *Rhipicephalus appendiculatus* and *Rhipicephalus zambeziensis* adults. *Medical and Veterinary Entomology*, 19, 245-250.
- Mtambo, J., M. Madder, W. van Bortel, D. Berkvens and T. Backeljau. 2007a. *Rhipicephalus appendiculatus* and *R. zambeziensis* (Acari: Ixodidae) from Zambia: a molecular reassessment of their species status and identification. *Experimental and Applied Acarology*, 41, 115-128.
- Mtambo, J., M. Madder, W. van Bortel, G. Chaka, D. Berkvens and T. Backeljau. 2007b. Further evidence for geographic differentiation in *R. appendiculatus* (Acari: Ixodidae) from Eastern and Southern provinces of Zambia. *Experimental and Applied Acarology*, 41, 129-138.
- Mulumba, M. 1999. Epidemiology of *Theileria parva* Theileriosis in Southern province of Zambia. PhD thesis. Institute of Tropical Medicine, Antwerp, Belgium.
- Norval, R.A.I., J.B. Walker and J. Colborne. 1982. The ecology of *Rhipicephalus zambeziensis* and *Rhipicephalus appendiculatus* (Acarina, Ixodidae) with particular reference to Zimbabwe. *Onderstepoort Journal of Veterinary Research*, 49, 181-190.
- Norval, R.A.I., B.D. Perry and A.S. Young. 1992. The epidemiology of theileriosis in Africa, pp 481. Academic Press, London.
- Ochanda, H., A.S. Young, G.F. Medley and B.D.Perry. 1998. Vector competence of 7 rhipicephalid tick stocks in transmitting 2 *Theileria parva* parasite stocks from Kenya and Zimbabwe. *Parasitology*, 116, 539-545.
- Pegram, R.G., B.D. Perry, F.L. Musisi and B.Mwanaumo. 1986. Ecology and phenology of ticks in Zambia: seasonal dynamics on cattle. *Experimental and Applied Acarology*, 2, 25-45.
- Pegram, R.G. and D.S. Banda. 1990. Ecology and phenology of ticks in Zambia: development and survival of free-living stages. *Experimental and Applied Acarology*, 8, 291-301.
- Ridley, M. 2004. *Evolution* (3rd Edition). Blackwell Publishing, Oxford UK.
- Silver, J.B. and M. Renshaw. 1999. Are mosquitoes from lower latitudes smaller? *Medical and Veterinary Entomology*, 13, 219-233
- Speybroeck, N., M. Madder, P. Van Den Bossche, J. Mtambo, N. Berkvens, G. Chaka, M. Mulumba, J. Brandt, L. Tirry and D. Berkvens. 2002. Distribution and phenology of ixodid ticks in southern Zambia. *Medical and Veterinary Entomology*, 16, 430-441.
- Speybroeck, N., M. Madder, H.H. Thulke, J. Mtambo, L. Tirry, G. Chaka, T. Marcotty and D. Berkvens. 2004. Variation in the tick complex *Rhipicephalus appendiculatus*/*Rhipicephalus zambeziensis*. *Journal of Vector Ecology*, 29, 347-354.

StataCorp. 2003. Stata/SE 8.0 for Windows statistical software, Stata Corporation, College Station, Texas.

Tempia, S. 1997. Comparison of the vectorial capacity of *Rhipicephalus appendiculatus* (Acari: Ixodidae) nymphs and adults originating from Eastern and Southern provinces of Zambia infected by *Theileria parva* Katete stock. MSc Thesis No. 65. Institute of Tropical Medicine, Antwerp, Belgium.

Walker, J.B., J.E. Keirans and I.G. Horak. 2000. The genus *Rhipicephalus* (Acari: Ixodidae). Cambridge University Press, UK.

Zieger, U., I.G. Horak and A.E. Caudwell. 1998. Dynamics of free-living ixodid ticks on a game ranch in the Central Province, Zambia. Onderstepoort Journal of Veterinary Research, 65, 49-59.

**Chapter 5 - INTRASPECIFIC VARIATION IN  
*RHIPICEPHALUS APPENDICULATUS* FROM EASTERN  
AND SOUTHERN PROVINCES**

**Based on the Manuscript:**

Mtambo, J., M. Madder, W. Van Bortel, D. Berkvens, G. Chaka and T. Backeljau.  
2007. Further evidence for geographic differentiation in *R. appendiculatus*  
(Acari: Ixodidae) from Eastern and Southern provinces of Zambia.  
*Experimental and Applied Acarology*, 41: 129-138.

## 5.1 Introduction

The Ixodid tick *Rhipicephalus appendiculatus* Neumann, 1901, one of the main field vectors of East Coast fever (ECF), a cattle disease, is widely distributed in eastern, southern and central African countries (Norval *et al.*, 1992) including Zambia (Pegram *et al.*, 1986, Speybroeck *et al.*, 2002). Studies in the biology, ecology and behaviour of *R. appendiculatus* in Zambia have shown considerable geographic variation within and between populations (Berkvens *et al.*, 1995; Chaka *et al.*, 1999, Madder *et al.*, 2002, Speybroeck *et al.*, 2002, Speybroeck *et al.*, 2004).

**Table 5.1: Published differences between Eastern province and Southern province *R. appendiculatus* stocks**

Feature	East <i>R.appendiculatus</i> stock	South <i>R.appendiculatus</i> stock	References
Diapause induction	Photoperiod i.e. shortday	obligatory	Madder <i>et al.</i> , 2002
Diapause intensity	Less intense	Greater intensity	Madder <i>et al.</i> , 2002
Body size	Mixed i.e. large and small	Large	Chaka <i>et al.</i> , 1999; Speybroeck <i>et al.</i> , 2004
Phenology	Bimodal	Unimodal	Berkvens <i>et al.</i> , 1998; Chaka <i>et al.</i> , 1999
<i>Theileria parva</i> (katete)	Lower infection rates	Higher infection rate	Tempia, 1997

In a recent study, 12S rDNA and ITS2 sequence data of *R. appendiculatus* and *R. zambeziensis* from Eastern and Southern provinces of Zambia, showed that *R. appendiculatus* from the Eastern province constitutes a bootstrap-supported monophyletic group within an unresolved assemblage of *R. appendiculatus* specimens from the Southern province (Mtambo *et al.*, 2007). Such intraspecific geographic genetic variation may have important taxonomical and epidemiological consequences (McLain *et al.*, 1995; Avise, 2000). The current work therefore aims at: (1) providing further evidence for the geographic genetic differentiation between *R. appendiculatus* from the Eastern and Southern provinces of Zambia and; (2) correlating the observed molecular differentiation with literature data on ecological differences between *R. appendiculatus* from the two provinces (Table 5.1).

To this end we sequenced a 600 bp fragment of the mitochondrial cytochrome oxidase subunit I (COI) gene and considered possible epidemiological implications of this geographic patterning in *R. appendiculatus*.

## 5.2 Materials and Methods

### 5.2.1 Sampling

Ticks were sampled from the Eastern (10°18-15°06S; 29°56-33°42E) and Southern (15°14-17°42S; 25°01- 28°40'E) provinces of Zambia (fig 5.1.) between 1997 and 2003. Ecologically, Zambia is divided into three agro-ecological zones (fig.5.1). Both the Eastern and Southern provinces fall into agro-ecological zones 1 and 2a. Zone 1 is characterised by the hottest (40°C) and driest (600mm) annual conditions. Rainfall is generally less than 800mm per annum. Zone 2a receives 800-1200mm of rain annually and is therefore a medium rainfall zone. The climate and vegetation of the Eastern province have been described by Berkvens *et al.* (1998). Briefly, the rainy season starts in November and ends in April. The hot dry season is from August to the beginning of the rainy season. There is an intervening cold dry season between May and July. The vegetation is broadly divided into four types, viz., (1) Munga woodland: fairly open woodland found on richer soils with a richer grass cover; (2) Miombo woodland: fairly closed woodland on poorer soils with sparse grass cover. These vegetation types (1) and (2) are mainly features of the plateau. (3) Mopane woodland: found in low lying valleys; (4) Grassland also known as dambos: these are open grasslands with very few or no trees; their drainage is poor and therefore they tend to get water logged in the rainy season. Grasslands serve as communal grazing areas. The ticks from Eastern province were collected in January of 2003 from the plateau districts of Chipata (Kamulaza, Wafa) and Petauke (Kalindawalo, Nyamphande) and Nyimba (Beni, Chipembi) a district on the fringes of the valley (fig. 5.2). These specimens were killed and preserved at -80°C. The climate and vegetation of the Southern province were described in Mulumba *et al.* (2000) and Speybroeck *et al.* (2002). The climate is characterized by a warm rainy season (November to April) which is followed by a cool dry season (May to August) and a hot dry season (September to October). The vegetation on the plateau is mainly Munga and Miombo woodlands. Mopane and scrub woodlands are found in the valley areas and areas of the Kalahari sands. Ticks from the Southern province were collected from the valley districts of Sinazongwe (Sinazeze), Gwembe (Syabwengo), Livingstone (Simonga) and the plateau districts of Mazabuka (Nkonkola, Nega Nega) and Monze (Nteme) (fig. 5.3). All the specimens were killed in 70% ethanol upon collection (1997) and stored in the same at ambient temperature.

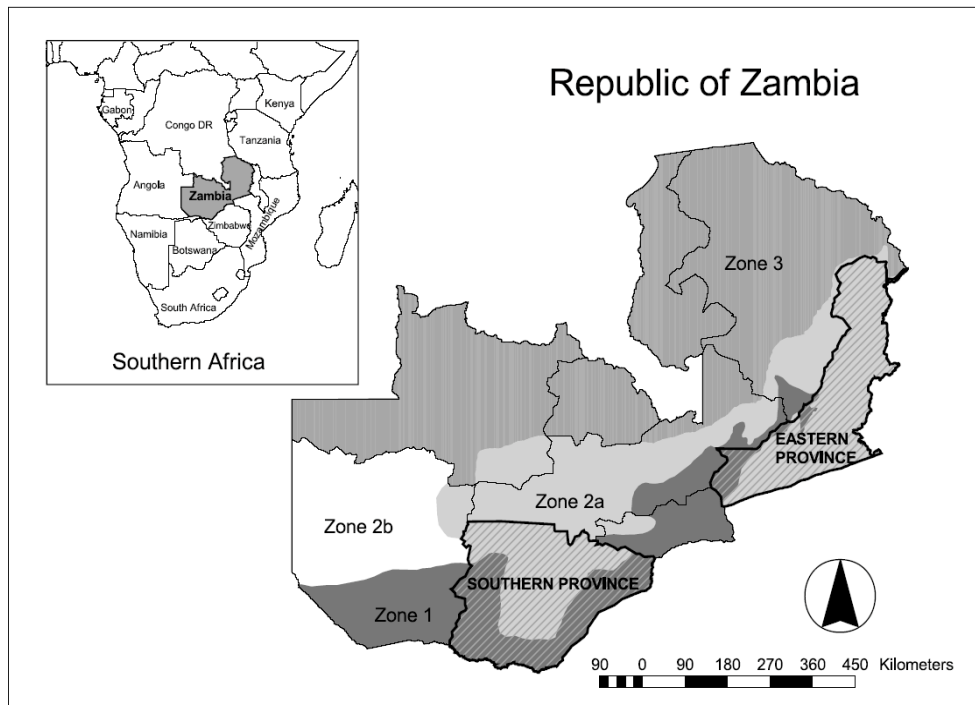

Figure 5.1: Locator map of Zambia showing the three agro-ecological zones

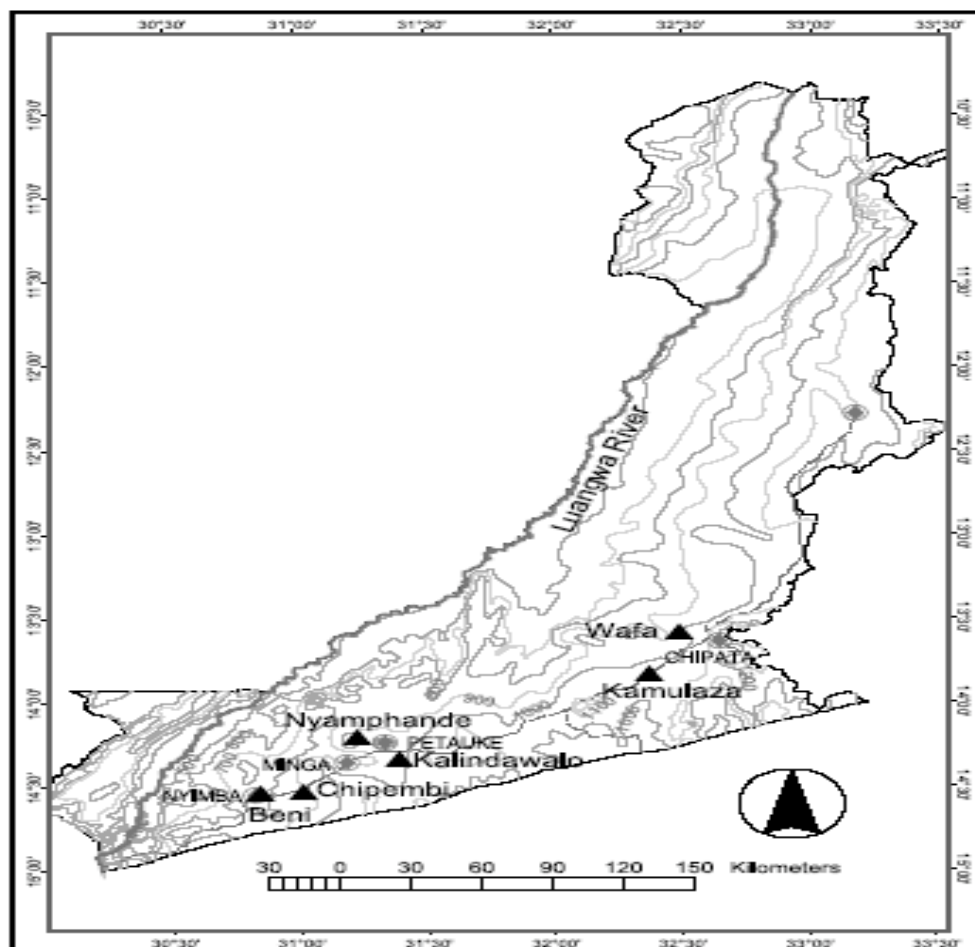
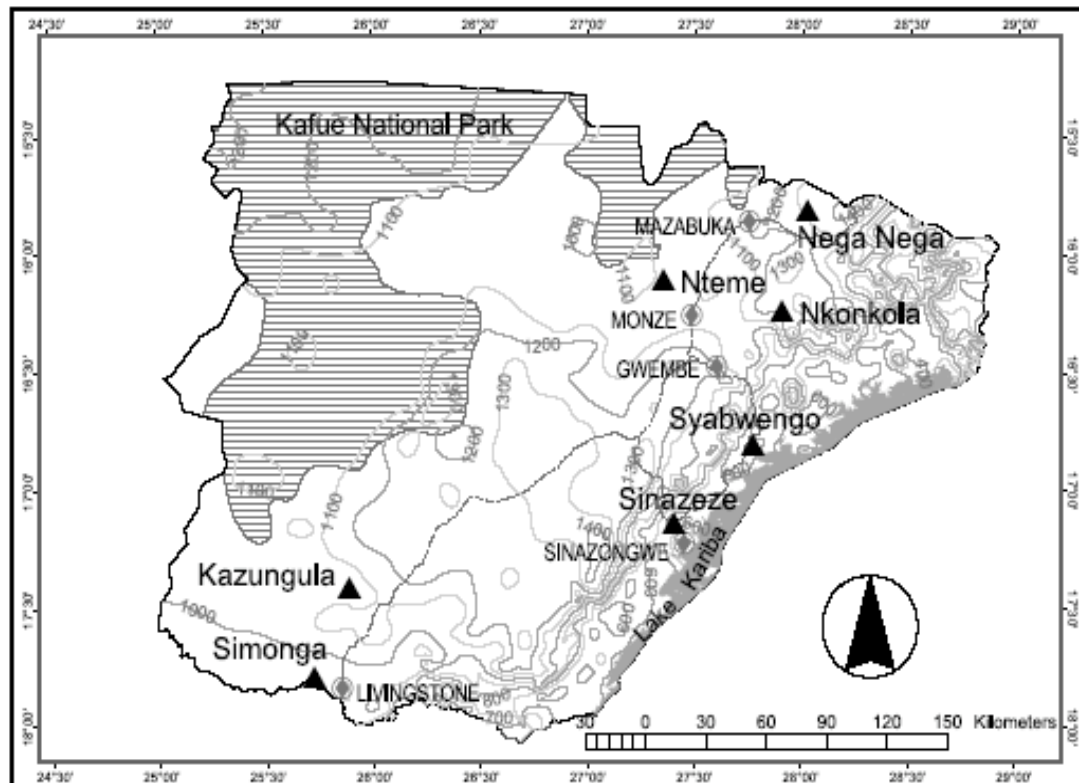

Figure 5.2: Map of the Eastern province showing areas of tick collection



**Figure 5.3: Map of the Southern province showing areas of tick collection**

### 5.2.2 Identification of ticks and DNA extraction

DNA extraction was based on the method of Boom *et al.* (1990, 1999) as described in Mtambo *et al.* (2006). All the 60 specimens of *R. appendiculatus* used in this study were identified by the use of a PCR-RFLP based on the digestion of the ITS2 with *BauI* (JM unpublished). This allows distinguishing between *R. appendiculatus* and the closely related *R. zambeziensis*.

### 5.2.3 PCR amplification, DNA sequencing and alignment

Amplification and sequencing of the COI were set up as described in Mtambo *et al.* (2006). A total of 60 amplicons were sequenced. Sequences were assembled with ClustalX 1.83 (Thompson *et al.*, 1997), visually inspected and manually edited in GeneDoc version 2.6.001 (Nicholas & Nicholas, 1997). Multiple alignments were executed in ClustalX 1.83 with its default settings and the alignments were visually inspected in GeneDoc.

### 5.2.4 Phylogenetic analysis

Using the program Modeltest (Posada and Crandall, 1998) the best fit model of evolution for the COI sequences was determined as the GTR +I (General time reversible with proportion of Invariable sites). The parameters of the model were: base frequencies; freqA=0.2755, freqC=0.1832, freqG=0.1376 and freqT=0.4037; Rmat=1.785, 3.474, 3.765, 0.174, 10,830 and 1.000; Rates=equal and proportion of invariable sites (I) =0.6340. Sequences of *R. evertsi evertsi* and *R. turanicus* were included in the alignment as outgroups. (The alignment file is available by anonymous FTP from <ftp.ebi.ac.uk> in directory pub/databases/embl/align under the accession numbers **ALIGN\_001061**). *Rhipicephalus evertsi evertsi* and *R. turanicus* were collected from Kazungula and Simonga respectively in the Livingstone district. These species were morphologically identified with the identification keys of Walker *et al.* (2000). The sequences were subjected to a BLAST to confirm the identity of the target sequences. A distance tree was generated with Neighbour Joining (NJ) in PAUP\* version 4.0b10 (Swofford, 2003) with the F84 as the distance measure using the parameters of the GTR +I model. The model was next used in a Maximum Likelihood (ML) analysis. The stabilities of the NJ and ML trees were evaluated via bootstrap analysis with 1000 iterations. Finally the same parameters were used in a Bayesian phylogenetic inference in MrBayes (Ronquist and Huelsenbeck, 2003). The starting tree for each of the two simultaneous runs was random. We allowed for 1 cold chain and 3 heated chains (default settings). Stationarity was achieved after 600,000 cycles.

## 5.3 Results

### 5.3.1 PCR amplification and sequence alignment statistics

The COI gene fragment comprised 478 aligned bp with 14 polymorphic sites, 12 of which were parsimony informative and 2 were singletons. There was only a single haplotype in the Southern province, while there were five haplotypes in the Eastern province (Table 5.2). Four of the five Eastern province haplotypes (i.e. haplotypes 2-5) only occurred in the plateau localities of Chipata and Petauke. The fifth (haplotype 1) was identical to the single Southern province haplotype and was only found in Nyimba, a district on the fringes of the valley.

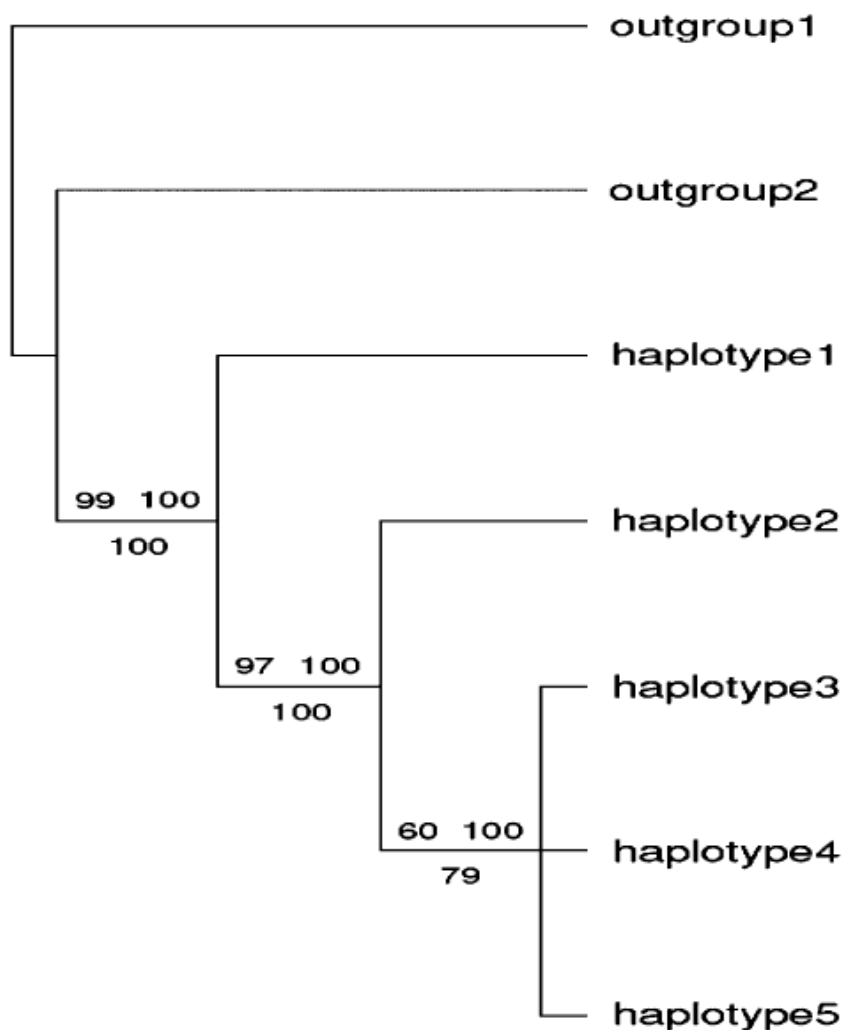

**Table 5.2: Polymorphism in the mitochondrial COI gene fragment in *R. appendiculatus* from Eastern and Southern provinces of Zambia**

HAPLOTYPE	No.ofspecimens	VARIABLEBASE POSITIONS														SOURCE	
		12	94	147	159	212	246	303	315	345	372	394	432	453	465	Southern	Eastern
Haplotype 1	40	T	C	T	C	A	C	A	T	G	T	G	G	C	C	All districts	Nyimba
Haplotype 2	8	C	T	C	T	-	T	G	C	A	G	-	-	T	T		Chipata, Petauke
Haplotype 3	1	-	-	-	-	-	-	-	-	-	-	A	A	-	-		Chipata
Haplotype 4	1	-	-	-	-	C	-	-	-	-	-	G	-	-	-		Chipata
Haplotype 5	10	-	-	-	-	A	-	-	-	-	-	-	-	-	-		Chipata, Petauke

### 5.3.2 Phylogenetic analysis

The ML, NJ and Bayesian trees consistently revealed that the four haplotypes of the plateau populations from the Eastern province represent a strongly supported monophyletic group (Bootstrap support 97(ML) and 100 (NJ) and clade credibility support 100 (Bayesian inference) to the exclusion of the single haplotype of the Southern province and Nyimba district (fig. 5.4). Three of the four Eastern Province plateau haplotypes (3-5) formed an unresolved subclade which received partial bootstrap support (NJ 79% and Bayesian inference 100 %).



**Figure 5.4:** COI maximum likelihood (ML) cladogram for *Rhipicephalus appendiculatus* from Eastern and Southern provinces. Bootstrap and Clad credibility values: upper left =ML., upper right=Bayesian, bottom=NJ. Taxon labels: outgroup 1= *Rhipicephalus e. evertsi*, outgroup 2= *Rhipicephalus turanicus*. Haplotype location: Haplotype 1=Southern province and Nyimba district (Eastern province); Haplotype 2-5=Eastern province plateau districts

## 5.4 Discussion

The COI tree (fig. 5.4) agrees with previous 12S rDNA sequence analyses results (MJ in prep) by revealing that the plateau haplotypes of the Eastern province constitute a monophyletic group to the exclusion of the single Southern province and Nyimba district haplotype. The COI data further agreed with 12S rDNA data by having an equal number of haplotype diversity for the two provinces i.e. one for the Southern province and five for the Eastern province. In the COI data, as in the 12S rDNA, the one haplotype out of the five Eastern province haplotypes that was identical to the

single haplotype of the Southern province was from Nyimba district. The COI tree was similarly in agreement with the previous ITS2 data which showed support for the Eastern province plateau sequences as a monophyletic group within an assemblage of *R. appendiculatus* sequences from the Southern province and Nyimba district.

The solid support for the separation of *R. appendiculatus* from Southern and Eastern provinces into two groups on the gene tree considered here agrees with published differences (Table 5.1). *Rhipicephalus appendiculatus* from the two provinces further differ by having different adult phenologies (Berkvens *et al.*, 1998; Chaka, 2001; Speybroeck *et al.*, 2002) which are related to the differences in diapause induction and intensity (Madder *et al.*, 2002; Speybroeck *et al.*, 2002). In addition, Tempia (1997) reported higher infection rates for *Theileria parva* (Katete), strain from the Eastern province in adults of *R. appendiculatus* from the Southern province than *R. appendiculatus* from the Eastern province plateau. These differences manifest themselves in significant differences in the epidemiology of ECF between the Southern and Eastern provinces (Speybroeck *et al.*, 2004; Billiouw, 2005).

While both Southern and Eastern provinces fall within the same two agro-ecological zones (fig. 5.1), there are two major climatic differences between them i.e., (1) Southern province experiences lower mean temperatures in the cold dry season and (2) generally receives lower total annual rainfall than Eastern province (Speybroeck *et al.*, 2002). However, significantly higher differences in both total annual rainfall and temperatures exist between valley and plateau locations within both provinces. We therefore propose that haplotype 1 and the Eastern province plateau haplotypes represent geographical rather than ecologically differentiated haplotypes. The existence of the two geographic subdivisions may be an indication of partial isolation of the two geographic stocks resulting in insufficient demographic connection between them (Avise, 2000).

The presence of more than one haplotype in the Eastern province may be testimony to the more than one life history strategy developed by this species in this region (Madder, 1999). Indeed, Madder (1999) suggested that the population in the eastern province, might consist of individuals with genetically variable critical photoperiod thresholds for diapause induction. However, which haplotype or haplotypes coincide with the reported phenotype groups remains to be decided. This, however, is not to suggest that the COI is involved in diapause control. Using the tool for determination

of the physiological age of *R. appendiculatus* (Chaka *et al.*, 2001) it should be possible to find if there is any correspondence between these haplotypes and the reported phenotypes. On the contrary, only a single COI haplotype was found in the Southern province. One factor, which though singly may not explain this phenomenon completely, is that the dispersal rate of ticks in the province is quite high (own unpublished observation). This is due to the traditional cattle keeping system in which cattle are grazed on communal areas and allowed to move from foci of disease outbreaks to disease free areas. Social-economic activities like the payment of stock “on the hoof” as dowry for marriage, sharing and hiring out oxen for ploughing, using oxen as transport to health centres and trekking to selling or trucking points also contribute to this high movement.

It is interesting that the Nyimba district (Eastern province) haplotype is identical to the Southern province haplotype. This is in spite of the district’s geographical proximity to the Eastern province plateau and the absence of a topographical barrier between Nyimba (on the fringes of the valley) and Petauke on the plateau (Berkvens *et al.*, 1998) that would otherwise prevent movement of hosts (livestock and wild animals) and therefore dispersal of the ticks. Despite that, Berkvens *et al.* (1998) did predict a limit in the westward spread of *R. appendiculatus* on the eastern plateau to around Minga an outpost 35 km west of Petauke (55km East of Nyimba) because of unfavourable conditions i.e. higher minimum temperatures and lower relative humidity for *R. appendiculatus*. That the Eastern province plateau haplotypes were not found in Nyimba is in line with that prediction but a contradiction for haplotype 1. However, Speybroeck *et al.* (2004) suggested that *R. appendiculatus* stocks that do not go through a diapause cannot survive in areas with unfavourable conditions where a diapause is necessary. We, however, further add that *R. appendiculatus* stocks that do not go through an obligatory diapause may not survive harsh conditions. Conversely, *R. appendiculatus* stocks that go through an obligatory diapause are likely to survive a wide range of conditions within the acceptable limits of this species survival (Speybroeck *et al.*, 2004). Therefore, we hypothesize that in Nyimba (an area with unfavourable conditions) *R. appendiculatus* may require an obligatory diapause to survive, just like the Southern province ticks with an identical haplotype. If this assumption is correct, we suggest that haplotype 1 has more chances of advancing

eastwards on the Eastern province plateau, than any of the four Eastern plateau haplotypes advancing westwards into the valley.

The reported difference in the epidemiology of ECF in Eastern and Southern Zambia (Billiouw, 2005; Speybroeck *et al.*, 2004) is therefore due in a large part to the difference in the vector ticks. The spread and establishment of either group of ticks into another group's area of endemicity has a potential to change the epidemiology of ECF for that area. This would be due to the differences in infection rates for *Theileria parva* strain or strains present in the new area of establishment (Tempia, 1997) and the differences in ticks' life history traits. There is therefore need to both confirm whether haplotype 1 ticks from Nyimba are an extension of the southern province ticks and therefore undergo an obligate diapause. Further the biology of the progeny of this haplotype with the Eastern province plateau haplotypes should be explored. This may help reveal further future epidemiological possibilities.

## 5.5 References

- Avise, J.C. 2000. Phylogeography: the history and formation of species. Harvard University Press, Cambridge and London.
- Berkvens, D.L., R.G. Pegram and J.R.A. Brandt. 1995. A study of the diapausing behaviour of *Rhipicephalus appendiculatus* and *R. zambeziensis* under quasi-natural conditions in Zambia. *Medical and Veterinary Entomology*, 9, 307-315.
- Berkvens, D.L., D.M. Geysen, G. Chaka, M. Madder and J.R.A. Brandt. 1998. A survey of the ixodid ticks parasitizing cattle in the Eastern province of Zambia. *Medical and Veterinary Entomology*, 12, 234-240.
- Billiouw, M. 2005. The epidemiology of bovine theileriosis in the Eastern province of Zambia. PhD. thesis. Ghent university, Ghent, Belgium.
- Boom, R., C.J.A. Sol, M.M.M. Salimans, C.L. Jansen, P.M.E. Wertheim-van Dillen and J. Van Der Noordaa. 1990. Rapid and simple method of purification of nucleic acids. *Journal of Clinical Microbiology*, 28, 495-503.
- Boom, R., C. Sol, M. Beld, J. Weel, J. Goudsmit and P.M.E. Wertheim-van Dillen. 1999. Improved silica-guanidiniumthiocyanate DNA isolation procedure based on selective binding of bovine alpha-casein to silica particles. *Journal of Clinical Microbiology*, 37, 615-619.
- Chaka, G., M. Billiouw, D.M. Geysen and D.L. Berkvens. 1999. Spatial and temporal variation in *Rhipicephalus appendiculatus* size in eastern Zambia. *Tropical Medicine and International Health*, 4, A43-A48.
- Chaka, G., M. Madder, N. Speybroeck, S. Tempia, K. Tona and D. Berkvens. 2001. Determination of physiological age of *Rhipicephalus appendiculatus* (Acari: Ixodidae). *Systematic and Applied Acarology special publications*, 10, 1-16.
- Chaka, G. 2001. Eco-physiology of *Rhipicephalus appendiculatus* (Acari: Ixodidae) in eastern Zambia, pp 89-105. PhD Thesis. Institute of Tropical Medicine, Antwerp (ITMA), Antwerp, Belgium.
- Madder, M. 1999. Behavioural Diapause in *Rhipicephalus appendiculatus* Neumann (Acari: Ixodidae), pp 109-122. PhD Thesis, Ghent University.
- Madder, M., N. Speybroeck, J. Brandt, L. Tirry, I. Hodek and D. Berkvens. 2002. Geographic variation in diapause response of adult *Rhipicephalus appendiculatus* ticks. *Experimental and Applied Acarology*, 27, 209-221.
- McLain, D.K., D.M. Wesson, J.H. Oliver Jr. and F.H. Collins. 1995. Variation in ribosomal DNA internal transcribed spacer 1 among Eastern populations of *Ixodes scapularis* (Acari: Ixodidae). *Journal of Medical Entomology*, 32, 353-360.
- Mtambo, J., W. Van Bortel, M. Madder, P. Roelants and T. Backeljau. 2006. Comparison of preservation methods of *Rhipicephalus appendiculatus* (Acari: Ixodidae) for reliable DNA amplification by PCR. *Experimental and Applied Acarology*, 38, 189-199.
- Mulumba, M., N. Speybroeck, M. Billiouw, D.L. Berkvens, D.M. Geysen and J.R.A. Brandt. 2000. Transmission of theileriosis in the traditional sector in the

- southern province of Zambia during 1995-1996. *Tropical Animal Health and Production*, 38, 303-314.
- Nicholas, K.B. and H.B. Nicholas jr. 1997. GeneDoc: a tool for editing and annotating multiple sequence alignments. Distributed by author. <http://www.psc.edu/biomed/genedoc/gddl.htm>
- Norval, R.A.I., B.D. Perry and A.S. Young. 1992. The epidemiology of theileriosis in Africa, pp 99. Academic Press, London.
- Pegram, R.G., B.D. Perry, F.L. Musisi and B. Mwanaumo. 1986. Ecology and phenology of ticks in Zambia: seasonal dynamics in cattle. *Experimental and Applied Acarology*, 2, 25-45.
- Posada, D. and K.A. Crandall. 1998. Modeltest: testing the model of DNA substitution. *Bioinformatics*, 14, 817-818.
- Ronquist, F. and J.P. Huelsenbeck. 2003. MRBAYES: Bayesian phylogenies under mixed models. *Bioinformatics*, 19, 1572- 1574.
- Speybroeck, N., M. Madder, P. Van Den Bossche, J. Mtambo, N. Berkvens, G. Chaka, M. Mulumba, J. Brandt, L. Tirry and D. Berkvens. 2002. Distribution and phenology of ixodid ticks in Southern Zambia. *Medical and Veterinary Entomology*, 16, 430-441.
- Speybroeck, N., M. Madder, H.H. Thulke, J. Mtambo, L. Tirry, G. Chaka, T. Marcotty and D. Berkvens. 2004. Variation in body size in the tick complex *Rhipicephalus appendiculatus/Rhipicephalus zambeziensis*. *Journal of Vector Ecology*, 29, 347-354.
- Swofford, D.L. 2003. PAUP\* Phylogenetic Analysis using Parsimony (\*and other methods). Sinauer Associates, Sunderland, Massachusetts.
- Tempia, S. 1997. Comparison of the vectorial capacity of *Rhipicephalus appendiculatus* (Acari: Ixodidae) nymphs and adults originating from eastern and southern provinces of Zambia infected by *Theileria parva* Katete stock. M.Sc. thesis No. 65. Institute of Tropical Medicine, Antwerp (ITMA), Belgium
- Thompson, J.D., T. J. Gibson, F. Plewniak, F. Jeanmougin and D.G. Higgins. 1997. The ClustalX windows interface: flexible strategies for multiple sequence alignment aided by quality analysis tools. *Nucleic Acids Research*, 25, 4876-4882.
- Walker, J.B., J.E. Keirans and I.G. Horak. 2000. The Genus *Rhipicephalus* (Acari: Ixodidae): a guide to the brown ticks of the world. Cambridge University Press, Cambridge.





**Chapter 6 - CORRELATING GENETIC AND  
ECOLOGICAL VARIATION IN *RHIPICEPHALUS*  
*APPENDICULATUS* FROM ZAMBIA WITH  
*R. APPENDICULATUS* FROM EASTERN AND SOUTHERN  
AFRICA**

**Based on the Manuscript:**

Jupiter Mtambo, Maxime Madder, Wim Van Bortel, Dirk Geysen, Dirk Berkvens and Thierry Backeljau. 2007. Genetic variation in *Rhipicephalus appendiculatus* (Acari: Ixodidae) from Zambia: Correlating genetic and ecological variation with *Rhipicephalus appendiculatus* from east and southern Africa. *Journal of Vector Ecology*, 32, 168-175.

## 6.1 Introduction

The African brown ear tick *Rhipicephalus appendiculatus* Neumann, 1901, is the main field vector of the haemoprotozoan parasite *Theileria parva*, the causative agent of East Coast fever (ECF). East Coast fever is one of the most economically important cattle diseases in Zambia (Makala *et al.*, 2003) and other east, central and southern African countries due to the high mortality, morbidity and other production losses associated with the disease (Mukhebi *et al.*, 1992). The distribution of *R. appendiculatus* is not continuous but is limited by factors like the availability of suitable hosts, vegetation and climate (Norval *et al.*, 1992a; Walker *et al.*, 2000). In addition, climate influences the number of generations per year (Norval *et al.*, 1992b).

Based on the number of generations per year, the adult body size and the expression or non-expression of a behavioural diapause (the suppression of host seeking activity in unfed adult ticks), *R. appendiculatus* have been divided into three groups (Madder *et al.*, 1999; Madder *et al.*, 2002 ; Speybroeck *et al.*, 2004 ). The first group comprises *R. appendiculatus* stocks that cycle through two or more generations per year originating from parts of east Africa e.g. Kenya, Rwanda, Burundi, Tanzania and Uganda where the climate is characterised by short dry seasons and high ambient humidity throughout most of the year (Smith, 1969a; Smith, 1969b; Tatchell and Easton, 1986; Kaiser *et al.*, 1988). The ability of the east African stocks to cycle through more than one generation per year has been attributed to the absence of a long dry season which precludes the necessity for a behavioural diapause (Berkvens *et al.*, 1995; Madder *et al.*, 2002) in these stocks. Further, climate, as it is influenced by latitude, has an effect on the adult body size of some insects (James *et al.*, 1995; Silver and Renshaw, 1999) and seems to be the case for *R. appendiculatus* (Speybroeck *et al.*, 2004). The latter authors have described east African stocks to be of smaller adult body size than southern African stocks.

The southern African stocks (i.e. stocks from Southern province of Zambia through Zimbabwe to South Africa) constitute the second group (Madder *et al.*, 2002; Speybroeck *et al.*, 2004). The climate of southern Africa is marked by a well defined rainy season which is followed by a dry season of almost equal duration. *Rhipicephalus appendiculatus* in this region cycles through one generation with peak adult activity coinciding with the rainy season (Short and Norval, 1981; Minshull and

Norval, 1982; Paine, 1982; Pegram *et al.*, 1986; Pegram and Banda, 1990; Speybroeck *et al.*, 2002). Southern African stocks exhibit either an obligatory or a very intense, photoperiod-induced (short day) behavioural diapause (Pegram and Banda, 1990; Norval *et al.*, 1991; Madder *et al.*, 2002) that allows them to delay oviposition until conditions favourable for the survival of eggs and larvae, the most vulnerable stages of their life cycle, are present. Termination of behavioural diapause in these stocks is determined by ageing (Southern province of Zambia) or in the case of Zimbabwe increasing photoperiod (Madder *et al.*, 2002). A comparatively larger adult body size in southern African stocks has been associated with the ability to survive harsh conditions (higher temperature, low ambient humidity and delayed feeding) during diapause (Speybroeck *et al.*, 2004).

The third group consists of *R. appendiculatus* stocks from the Eastern province of Zambia whose ecology has been described as “transition” between east and southern African stocks (Chaka *et al.*, 1999; Madder *et al.*, 1999; Speybroeck *et al.*, 2004) based on the following observations: (a) *R. appendiculatus* stocks from the Eastern province of Zambia have an average adult body size that is intermediate between that of *R. appendiculatus* from east and southern Africa (Speybroeck *et al.*, 2004), (b) their phenology is characterised by two adult activity periods per year (Berkvens *et al.*, 1998; Chaka *et al.*, 1999) in spite of a climate that is marked by well defined alternate rainy and dry seasons of approximately equal duration, and (c) their expression of behavioural diapause is mixed i.e. ticks may or may not enter behavioural diapause depending on the amounts of rain or length of the rainy season (Madder *et al.*, 2002). Diapause in the Eastern province stocks is terminated by ageing (Madder *et al.*, 2002). Recently Mtambo *et al.* (2007a) and Mtambo *et al.* (2007b) have shown that *R. appendiculatus* from Eastern and Southern provinces of Zambia are geographically genetically differentiated.

The aims of the current work were two-fold: (1) to clarify the phylogenetic relationship of the two geographic genetically differentiated stocks of *R. appendiculatus* from Southern and Eastern provinces that are ecologically classified as “southern African” and “transition” respectively with those of east and southern Africa in general and; (2) to compare the resultant phylogenetic relationships with the three group ecological characterization i.e. east African, transition (Eastern province of Zambia) and southern African stocks.

## 6.2 Materials and Methods

*Rhipicephalus appendiculatus* were collected from Zambia, Rwanda, Grande Comore, Zimbabwe and South Africa. Adults of *R. appendiculatus* stocks from Zambia from Southern and Eastern provinces were collected from cattle in 1997 and 2003, respectively. Southern province tick collections were from the plateau districts of Mazabuka (15°52' 0S, 27°46'0E) and Monze (16°16'60S, 27°28'60E) and the valley areas of Gwembe (16°49'0S, 27°46'60E), Livingstone (17°49'60S, 25°23'60E) and Sinazongwe (17°7'60S, 27°25'0E) districts. Ticks collected from the Southern province were killed in 70% ethanol immediately after collection. They were preserved in 70% ethanol in sealed vacutainer tubes at ambient temperatures. In Eastern province ticks were collected from the plateau districts of Chipata (13°37'60S, 32°38'60E) and Petauke (14°15'0S, 31°19'60E) and Nyimba (14°33'0S, 30°49'60E) a district on the fringes of the eastern province plateau and the Luangwa valley. These ticks were preserved at -80°C. In Rwanda, ticks were collected from cattle in different agro-ecological regions of the country in the districts of Byumba, Kibuye, Gitarama, Gikongoro, Kigali and Kibungo in 2004. These ticks were killed in 70% ethanol immediately upon capture. Later they were washed in tap water, air dried and packed in Ziplock bags with silica gel and preserved at 4°C. Ticks from South Africa were collected from cattle in Rietvlei (29°10'60S, 30°16'60E) and Hluhuwe (28°08'S, 32°09'60E) in the KwaZulu Natal midlands in 2000 and 2004, respectively. These specimens were killed and preserved in 70% ethanol. The ticks from Grande Comore were collected from cattle in May 2004 at Madjeouéni (11°49'18S, 43°16'41E) on the north-eastern part of the island. They were killed and preserved in 70% ethanol. Ticks from Zimbabwe were collected from cattle in West Mashonaland in 2000. They were left to die naturally after collection, dried and then stored in sealed conical tubes at ambient temperature. Different stocks were subjected to different preservation methods appropriate to the specific purposes for which they were collected other than this work.

DNA was isolated using the method of Boom *et al.* (1990, 1999). The primers, PCR conditions and temperature profiles used for amplification of the ITS2 and the COI including the sequencing techniques have been described by Mtambo *et al.* (2006). Mitochondrial 12S rDNA was amplified with the primers SR-J-1499 (5'-TACTATGTTACGACTTAT-3') and SR-N-14594 (5'-

AAACTAGGATTAGATACCC -3') (Simon *et al.*, 1994). The PCR conditions and thermal cycler temperature profile for amplification of the 12S rDNA were identical to those used in the amplification of the COI (Mtambo *et al.*, 2006). To distinguish between *R. appendiculatus* and the morphologically very closely related *Rhipicephalus zambeziensis* Walker, Norval and Corwin, 1981, a PCR-RFLP technique (Mtambo *et al.*, 2007b) was used. Briefly ITS2 amplicons of the specimens were digested with the restriction endonuclease *BauI* in a 25 $\mu$ L volume containing 17  $\mu$ L MqW, 2.5  $\mu$ L 10X buffer (Tango™), 0.5  $\mu$ L Enzyme (0.1U; *BauI*), and 5  $\mu$ L amplicon. The mixture was incubated at 37°C for 150 min. Fragment profiles were resolved by electrophoresis through 2% (w/v) agarose gel at 100 volts for 30 min and visualized after staining for 30 min in ethidium bromide.

Multiple alignments were generated for 59 (ITS2), 59 (COI) and 58 (12S rDNA) gene sequences using default options in ClustalX 1.83 (Thompson *et al.*, 1997). The alignments were imported into Genedoc ver.2.6.001 (Nicholas and Nicholas, 1997), wherein they were visually examined and redundant sequences were removed. The remaining sequences were subjected to a BLAST to confirm the target gene segment. These sequences were then aligned together with sequences of *Rhipicephalus turanicus* Pomerantsev, 1936 (accession numbers **DQ849267** [ITS2]; **DQ849231** [12S rDNA]; **DQ859260** [COI]) as the outgroup species. These alignments are available in the EMBL-Align database under the accession numbers: **ALIGN\_001066**=ITS2; **ALIGN\_001067**=COI; **ALIGN\_001065**=12S rDNA. The best models of evolution for the sequences of the three target genes were determined in Modeltest (Posada and Crandall, 1998) using the Akaike Information Criteria. Modeltest chose the General Time Reversible with a proportion of invariable sites (GTR+I) as the model best fitting the COI data with the following model parameters: base frequencies; freqA = 0.2755, freqC = 0.1832, freqG = 0.1376 and freqT = 0.4037; Rmat=1.7849, 3.4740, 3.7650, 0.1735 and 10.8297; Rates=equal and proportion of invariable sites (I) =0.6340. For the ITS2 data the GTR model with no invariable sites was the most appropriate. The parameters of the model were: base frequencies; freqA = 0.1839, freqC = 0.3016, freqG = 0.3487 and freqT = 0.1658; Rmat =0.9242, 1.5422, 1.3804, 0.3855 and 3.3218; Rates=equal and Pinvar (I) =0. The model best fitting the 12S rDNA was the K81uf+I. This model had the following parameters: base frequencies; freqA= 0.3658, freqC= 0.1178, freqG= 0.0916 and

freqT= 0.4248; Rmat= 1.0000, 2003660.7500, 1123197.3750, 1123197.3750 and 2003660.7500; Rates=equal and Pinvar (I) = 0.7203.

Phylogenetic relationships among the ITS2 sequences and COI and 12S rDNA haplotypes were evaluated by both a distance (NJ: Neighbour-joining) and a maximum likelihood (ML) analysis in PAUP\* (Swofford, 2003). Starting trees were obtained through random addition of input taxa with the heuristic search option and tree bisection-reconnection (TBR) branch swapping. In all the analyses gaps were treated as missing data. The reliability of the groups on the trees was evaluated through bootstrap analysis with 1,000 iterations with TBR branch swapping.

### 6.3 Results

Targeted genes failed to amplify in the dried *R. appendiculatus* material from Zimbabwe. The ones that amplified did not give interpretable sequences. Instead we obtained ITS2 (Accession No. **U97704**) and COI (Accession No. **AF132833**) sequences for Zimbabwe from GenBank. These and the rest of the sequences used in this study are summarised in Table 6.1. Sequences for the ITS2 and the two mitochondrial (COI and 12S rDNA) fragments obtained for *R. appendiculatus* material from Rwanda and Grande Comore appear in GenBank under accession numbers **DQ901321-DQ901355** for the ITS2, **DQ901356-DQ901363** for COI and **DQ901277-DQ901320** for 12S rDNA. Ticks from Zambia and South Africa appear in GenBank under the following accession numbers: ITS2= (**DQ849239-DQ849254** and **DQ849269-DQ849272**); 12S rDNA= (**DQ849203-DQ849218** and **DQ849233-DQ849236**); COI= (**DQ859261-DQ859266**). Specimens were submitted to the Royal Belgium Museum of Natural sciences under the General Inventory number **I.G. 30662**

There were five different ITS2, eight COI and five 12S rDNA sequences (Tables 6.2-6.4). The Eastern province had five COI and 12S rDNA haplotypes compared to one in both segments in the Southern province. The Eastern province and Rwanda shared some COI and 12S rDNA haplotypes. In addition COI and 12S rDNA haplotypes endemic to either Rwanda or the Eastern province but sympatric to the shared haplotypes were observed.

**Table 6.1: Source and numbers of *R. appendiculatus* sequences for the three gene segments analysed**

Country	Gene Segment	No. of Sequences
Rwanda	ITS2	15
	COI	15
	12S rDNA	15
Grande Comore	ITS2	2
	COI	2
	12S rDNA	2
Zambia	ITS2	35
	COI	35
	12S rDNA	35
Zimbabwe	ITS2	1
	COI	1
	12S rDNA	0
South Africa	ITS2	6
	COI	6
	12S rDNA	6

Results of the analysis of the ITS2 data did not provide support for grouping *R. appendiculatus* from Rwanda, Zambia (Eastern and Southern provinces) and South Africa into any special groupings. The COI tree had two well-supported groups (fig. 6.1). One group (BS values of 95 % [ML] and 100 % [NJ]) was an unresolved polytomy of Eastern province plateau and Rwanda haplotypes within which there is weak support (BS values 64 % [ML] and 67 % [NJ]) for the exclusion of Eastern province plateau haplotype 8. The second group had BS values of 70 % [ML] and 98 % [NJ]. This group comprised ticks from South Africa, Zimbabwe, Zambia (Southern province and the south west edges [Nyimba] on the Eastern province plateau) and Grande Comore. The 12S rDNA tree (fig. 6.2) was resolved into two groups (BS values 78 % [NJ] and 87% [ML]). One group consisted of Eastern province (Nyimba), Southern province of Zambia, South Africa and Grande Comore stocks while the second was made up of stocks from Rwanda and Eastern province plateau districts.

**Table 6.2: Variation of the ITS2 sequences in *R. appendiculatus* from six east, central and southern African countries**

Sequence No.	Number of Sequences	Variable Base Positions														Sequence Origin	
		34	135	346	364	400	408	445	509	510	606	755	788	850	1003		1006
Sequence 1	2	T	C	A	T	C	C	C	-	-	C	T	A	T	A	C	Zambia (East & South)
Sequence 2	26	-	-	-	-	-	-	T	-	-	-	-	-	-	-	-	Zambia (East & South), South Africa
Sequence 3	1	-	-	T	-	T	T	C	T	-	T	A	-	-	-	-	Zimbabwe (McIlwaine)
Sequence 4	25	-	C	A	T	C	C	T	-	-	C	G	T	T	-	-	Rwanda and Zambia (East)
Sequence 5	5	T	-	-	-	-	-	-	-	-	-	T	-	-	-	C	Grande Comore, Zambia(South), South Africa

Key: ▫ indel; — nucleotide identical to one immediately above, Zambia (South); Southern province of Zambia, Zambia (East); Eastern province of Zambia, Zambia (East & South); both Eastern and Southern provinces of Zambia.

**Table 6.3: Variation of the COI sequences in *R. appendiculatus* from five east, central and southern African countries**

HAPLOTYPE	No.of specimens	VARIABLE BASE POSITIONS																			SOURCES		
		12	24	57	94	147	159	165	211	240	246	261	303	315	339	345	372	393	394	432		453	465
Haplotype 1	30	T	G	T	C	T	C	T	A	G	C	T	A	T	T	G	T	A	G	G	C	C	Zambia (South and East), Zimbabwe, South Africa
Haplotype 2	2	-	-	C	-	-	-	-	-	-	-	-	-	-	-	-	-	-	-	-	-	-	Grande Comore
Haplotype 3	19	C	-	-	T	C	T	-	-	-	T	-	G	C	-	A	G	A	G	A	T	T	Zambia (East), Rwanda
Haplotype 4	1	-	-	-	-	-	-	-	-	-	-	-	-	-	-	-	-	-	A	-	-	-	Zambia (East)
Haplotype 5	1	-	-	-	-	-	-	C	-	-	-	-	-	-	-	-	-	G	-	-	-	-	Zambia (East)
Haplotype 6	1	-	-	-	-	-	-	A	-	-	-	-	-	-	-	-	-	G	-	-	-	-	Rwanda
Haplotype 7	1	-	-	-	-	-	C	-	A	-	-	-	-	-	-	-	-	A	-	-	-	-	Rwanda
Haplotype 8	4	-	-	-	-	-	T	-	G	-	-	-	-	-	-	-	-	-	G	-	-	-	Zambia (East)

Key: — nucleotide identical to one immediately above, Zambia (South); Southern province of Zambia, Zambia (East); Eastern province of Zambia, Zambia (East & South); both Eastern and Southern provinces of Zambia.

**Table 6.4: Variation of the 12S rDNA sequences in *R. appendiculatus* from five east, central and southern African countries**

Haplotype	Number of Sequences	Variable Base Positions						Haplotype location	
		69	81	88	164	220	309		315
Haplotype 1	33	T	T	T	T	G	G	A	Grande Comore, Zambia (East & South), South Africa
Haplotype 2	4	C	C	C	-	-	-	-	Zambia (East)
Haplotype 3	1	-	T	-	-	-	-	-	Zambia (East)
Haplotype 4	2	-	-	-	-	-	-	G	Rwanda and Zambia (East)
Haplotype 5	18	-	-	-	-	-	-	A	Rwanda and Zambia (East)



Key: “▪” indel (insertion deletion event), “–” “nucleotide same as one immediately above, Zambia (South); Southern province of Zambia, Zambia (East); Eastern province of Zambia, Zambia (East & South); both Eastern and Southern provinces of Zambia.

## 6.4 Discussion

The non-resolution of *R. appendiculatus* from Rwanda, Zambia, Zimbabwe and South Africa into any special groups by the current ITS2 data show that in spite of their ecological differences *R. appendiculatus* from Rwanda (east Africa), Zambia, Zimbabwe and South Africa (southern Africa) are one and the same species. However, the mitochondrial (12S rDNA and COI) DNA data show that, *R. appendiculatus* from Rwanda, Zambia, Zimbabwe and South Africa may be divided into two geographic genetically differentiated groups: (1) a group consisting of specimens from Rwanda and the plateau districts of the Eastern province of Zambia which we here refer to as the “east African genetic group (eAGG)” and, (2) a group comprising specimens from South Africa, Zimbabwe, Grande Comore, the Southern province of Zambia and the south western edges of the Eastern province plateau (Nyimba) in Zambia, which we have referred to as the “southern African genetic group (sAGG)” (fig.6.1 and 6.2). This geographic genetic differentiation into sAGG and eAGG is an indicator of possible temporal and/or spatial partial isolation of the two populations (Avise, 2000).

That the stocks from Eastern province that are considered transitional and stocks from Rwanda form a coherent monophyletic eAGG is at variance with their ecological groupings. The difference in ecology within the eAGG may be due to genetic polymorphism and or phenotypic plasticity. Eastern province transition stocks had five COI and 12S rDNA haplotypes respectively (compared to a single haplotype for both segments in all the southern African stocks). It is possible that some haplotypes may be favoured by the local conditions obtaining in one area more than in others, e.g. a shorter rainy season for Eastern province than most places in Rwanda or east Africa in general may be favourable to some haplotypes and not others. Which haplotype corresponds to a particular phenotype or phenotypes (size, diapause and phenology) under discussion cannot be ascertained with the current data.

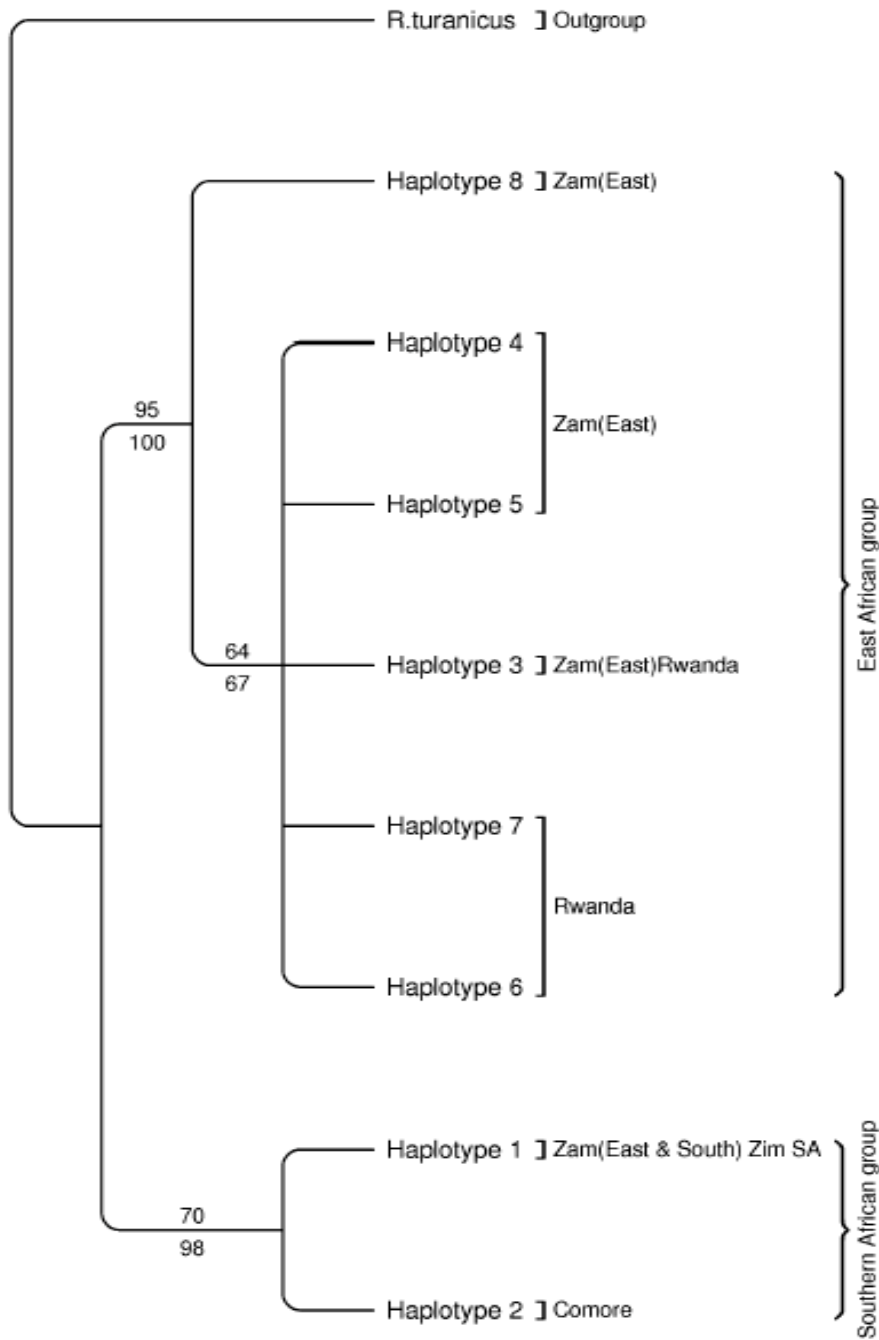

**Figure 6.1: A cladogram of COI haplotypes with Bootstrap support values; Top = ML; Bottom = Neighbour Joining (NJ); Names after the braces refer to the area where haplotypes were found. SA=South Africa; Zam (south) = Southern province of Zambia; Zam (east) = Eastern province of Zambia; Zam (East & South) = Eastern and Southern province of Zambia; Zim= Zimbabwe; Comore= Grand Comore**

It is also possible that individuals of the same haplotype may have varied phenotypic expression of their genotype in different environmental conditions. Indeed the most prevalent haplotypes i.e. COI haplotype 3 and 12S rDNA haplotype 5, were common to both Rwanda and the Eastern province. Similarly the reported difference in body size (Speybroeck *et al.*, 2004) in stocks arising from the same regions as those that constituted our eAGG may be attributed to genetic polymorphism, phenotypic plasticity, differences in latitude (Speybroeck *et al.*, 2004) and or any other unidentified local factors (Speybroeck *et al.*, 2004). Madder *et al.* (1999) studying diapause induction in three stocks of ticks from Kiambu (Kenya), Mtenguleni (Eastern province Zambia) and West Mashonaland (Zimbabwe) speculated the existence of an extensive genetic variation for diapause after observing as many responses as were the stocks. We however suggest that an extensive genetic variation for diapause might exist especially within the eAGG.

The composition of the sAGG agrees with the ecological similarities of the constituent stocks (Norval *et al.*, 1991; Madder *et al.*, 1999; Speybroeck *et al.*, 2004) except for Grande Comore ticks for which no prior ecological information was obtained. However, the Island of Grande Comore has a single rainy season (November to April) and a dry season of equal duration (May to October) with temperatures ranging from 20-28°C (Ben Daoud and Scheltens 1985). Such climatic conditions could be more favourable to the establishment of *R. appendiculatus* that express a behavioural diapause in order to synchronize oviposition with favourable environmental conditions (Speybroeck *et al.*, 2004). However, the actual situation in Grande Comore can only be established by further surveys as local ecological conditions may modulate these climatic conditions.

The failure of amplification of dried specimens from Zimbabwe may have been due to the nature of the killing and storage methods (Mtambo *et al.*, 2006).

Within the limits of this data we conclude that *R. appendiculatus* stocks from Southern and Eastern provinces of Zambia are geographically genetically differentiated stocks that might be part of two wider geographically genetically differentiated populations of *R. appendiculatus* in which Southern province stocks are part of the sAGG and the Eastern province stocks belong to the eAGG. It will be important to delimit the ranges of these two groups both within and outside Zambia

since their respective roles in the epidemiology of ECF may be different (McLain *et al.*, 1995; Avise, 2000; Speybroeck *et al.*, 2004).

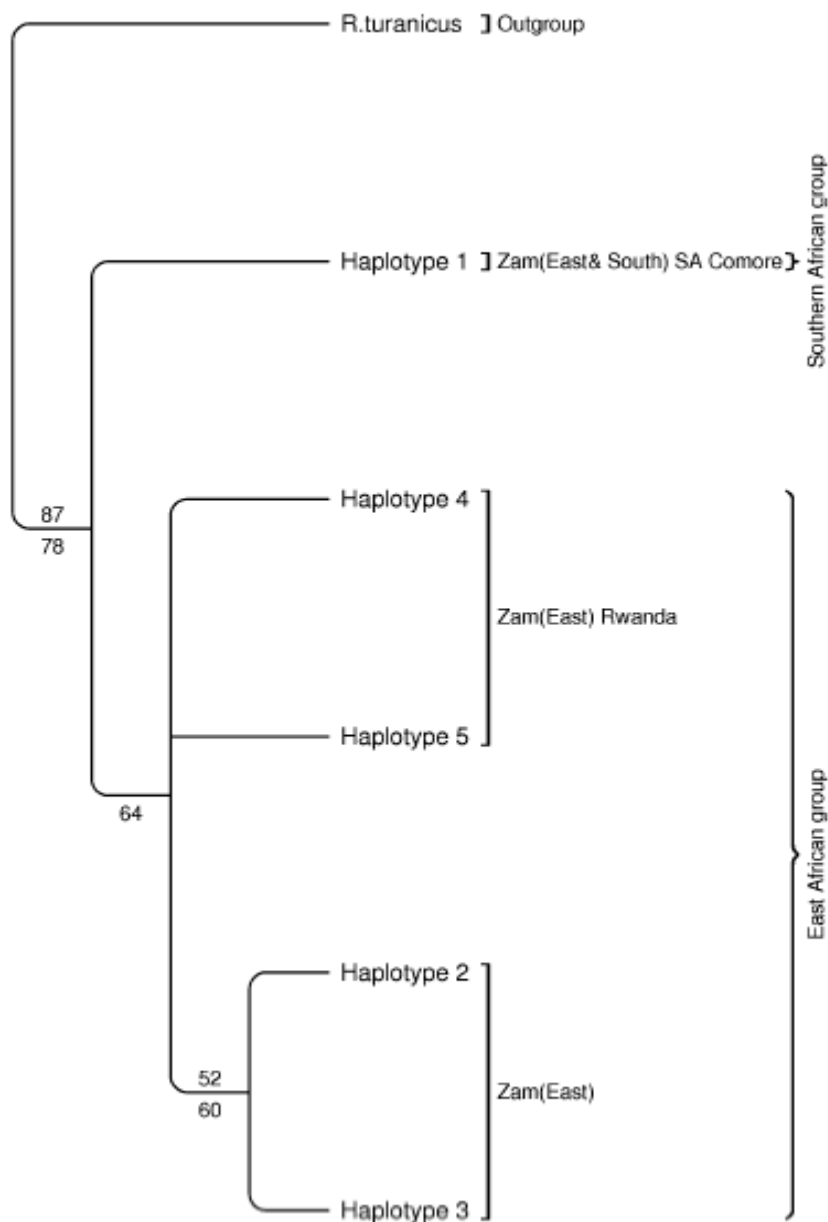

**Figure 6.2: A cladogram of 12S rDNA sequences with Bootstrap support values; Top = ML, Bottom= Neighbour Joining. Names after the braces refer to the area where haplotypes were found. SA=South Africa; Zam (south) = Southern province of Zambia; Zam (east) = Eastern province of Zambia; Zam (East & South) = Eastern and Southern province of Zambia; Comore= Grand Comore**

## 6.5 References

- Avise, J.C. 2000. Phylogeography: The history and formation of species. Harvard University Press, Cambridge and London.
- Ben Daoud, A. and E.B. Scheltens. 1985. Vegetable farming in the Comores; problems and prospects. *Acta Hort. (ISHS)* 153:109-114.
- Berkvens, D.L., R.G. Pegram and J.R.A. Brandt. 1995. A study of the diapausing behaviour of *Rhipicephalus appendiculatus* and *R. zambeziensis* under quasi-natural conditions in Zambia. *Medical and Veterinary Entomology*, 9, 307-315.
- Berkvens, D.L., D.M. Geysen, G. Chaka, M. Madder and J.R.A. Brandt. 1998. A survey of the ixodid ticks parasitizing cattle in the Eastern province of Zambia. *Medical and Veterinary Entomology*, 12, 234-240.
- Boom, R., C.J.A. Sol, M.M.M. Salimans, C.L. Jansen, P.M.E. Wertheim-van Dillen and J. Van Der Noordaa. 1990. Rapid and simple method of purification of nucleic acids. *Journal of Clinical Microbiology*, 28, 495-503.
- Boom, R., C. Sol, M. Beld, J. Weel, J. Goudsmit and P. M. E. Wertheim-van Dillen. 1999. Improved silica-guanidiniumthiocyanate DNA isolation procedure based on selective binding of bovine alpha-casein to silica particles. *Journal of Clinical Microbiology*, 37, 615-619.
- Chaka, G., M. Billiouw, D. M. Geysen and D. L. Berkvens. 1999. Spatial and temporal variation in *Rhipicephalus appendiculatus* size in eastern Zambia. *Tropical Medicine and International Health*, 4, A43-A48.
- James, A. C., R.B.R. Azevedo and L. Partridge. 1995. Cellular basis and development timing in a size cline of *Drosophila melanogaster*. *Genetics*, 140, 659-666.
- Kaiser, M.N., R.W. Sutherst, A.S. Bourne, L. Gorissen and R.B. Floyd. 1988. Population dynamics of ticks on Ankole cattle in five ecological zones in Burundi and strategies for their control. *Preventive Veterinary Medicine*, 6, 199-222.
- Madder, M., N. Speybroeck, J. Brandt and D. Berkvens. 1999. Diapause induction in adults of three *Rhipicephalus appendiculatus* stocks. *Experimental and Applied Acarology*, 23, 961-968.
- Madder, M., N. Speybroeck, J. Brandt, L. Tirry, I. Hodek and D. Berkvens. 2002. Geographic variation in diapause response of adult *Rhipicephalus appendiculatus* ticks. *Experimental and Applied Acarology*, 27, 209-221.
- Makala L.H., P. Mangani, K. Fujisaki and H. Nagasawa. 2003. The current status of major tick borne diseases in Zambia. *Veterinary Research*, 34, 27-45.
- McLain, D.K., D.M. Wesson, J.H. Oliver Jr. and F.H. Collins. 1995. Variation in ribosomal DNA internal transcribed spacer 1 among Eastern populations of *Ixodes scapularis* (Acari: Ixodidae). *Journal of Medical Entomology*, 32, 353-360.

- Minshull, J.I. and R.A.I. Norval. 1982. Factors influencing the spatial distribution of *Rhipicephalus appendiculatus* in Kyle Recreational Park, Zimbabwe. *South African Journal of Wildlife Research*, 12, 118-123.
- Mtambo, J., W. Van Bortel, M. Madder, P. Roelants and T. Backeljau. 2006. Comparison of preservation methods of *Rhipicephalus appendiculatus* (Acari: Ixodidae) for reliable DNA amplification by PCR. *Experimental and Applied Acarology*, 38, 189-199.
- Mtambo, J., M. Madder, W. Van Bortel, D. Berkvens and T. Backeljau. 2007a. *Rhipicephalus appendiculatus* and *R. zambeziensis* (Acari: Ixodidae) from Zambia: a molecular reassessment of their species status and identification. *Experimental and Applied Acarology*, 41, 115-128.
- Mtambo, J., M. Madder, W. Van Bortel, D. Berkvens, G. Chaka and T. Backeljau. 2007b. Further evidence for geographic differentiation in *R. appendiculatus* (Acari: Ixodidae) from Eastern and Southern provinces of Zambia. *Experimental and Applied Acarology*, 41: 129-138.
- Mukhebi, A.W., B.D. Perry and R. Kruska. 1992. Estimated economics of theileriosis control in Africa. *Preventive Veterinary Medicine*, 12, 73-85.
- Nicholas, K.B. and H.B. Nicholas Jnr. 1997. GeneDoc: a tool for editing and annotating multiple sequence alignments. Distributed by author. <http://www.psc.edu/biomed/genedoc/gddl.htm>
- Norval, R.A.I., J.A. Lawrence, A.S. Young, B.D. Perry, T.T. Dolan and J. Scott. 1991. *Theileria parva*: influence of vector, parasite and host relationships on the epidemiology of theileriosis in southern Africa. *Parasitology*, 102, 347-356.
- Norval, R.A.I., B.D. Perry and A.S. Young. 1992a. Chapter 4 (pp 99-130). Tick Vectors of Theileriosis *In: The epidemiology of theileriosis in Africa*, pp 481. Academic Press, London.
- Norval, R.A.I., B.D. Perry and A.S. Young. 1992b. Chapter 6 (pp 155-180). Vector Population Dynamics *In: The epidemiology of theileriosis in Africa*, pp 481. Academic Press, London.
- Paine, G.D. 1982. Ticks (Acari: Ixodoidea) in Botswana. *Bulletin of Entomological Research*, 72, 1-16.
- Pegram, R.G., B.D. Perry, F.L. Muisi and B. Mwanaumo. 1986. Ecology and phenology of ticks in Zambia: seasonal dynamics on cattle. *Experimental and Applied Acarology*, 2, 25-45.
- Pegram, R.G. and D.S. Banda. 1990. Ecology and phenology of cattle ticks in Zambia: development and survival of free living stages. *Experimental and Applied Acarology*, 8, 291-301.
- Posada, D. and K.A. Crandall. 1998. Modeltest: testing the model of DNA substitution. *Bioinformatics*, 14, 817-818.
- Short, N. J. and R.A.I. Norval. 1981. The seasonal activity of *Rhipicephalus appendiculatus*, Neumann 1901 (Acarina: Ixodidae) in the highveld of Zimbabwe. *Journal of Parasitology*, 67, 77-84.

- Silver, J.B and M. Renshaw. 1999. Are mosquitoes from lower latitudes smaller? *Medical and Veterinary Entomology*, 13, 219-223.
- Simon, C., F. Frati, A. Beckenbach, B. Crespi, H. Liu and P. Flook. 1994. Evolution, weighting and phylogenetic utility of mitochondrial gene sequences and a compilation of conserved polymerase chain reaction primers. *Annals of the Entomological Society of America*, 87, 651- 701.
- Smith, M.W. 1969a. Variations in tick species and populations in the Bugisu district of Uganda part I. *Bulletin of Epizootic Diseases of Africa*, 17, 55-75.
- Smith, M.W. 1969b. Variations in tick species and populations in the Bugisu district of Uganda part II. *Bulletin of Epizootic Diseases of Africa*, 17, 77-105.
- Speybroeck, N., M. Madder, P. Van Den Bossche, J. Mtambo, N. Berkvens, G. Chaka, M. Mulumba, J. Brandt, L. Tirry and D. Berkvens. 2002. Distribution and phenology of ixodid ticks in southern Zambia. *Medical and Veterinary Entomology*, 16, 430-441.
- Speybroeck, N., M. Madder, H.H. Thulke, J. Mtambo, L. Tirry, G. Chaka, T. Marcotty and D. Berkvens. 2004. Variation in body size in the tick complex *Rhipicephalus appendiculatus/Rhipicephalus zambeziensis*. *Journal of Vector Ecology*, 29, 347-354.
- Swofford, D.L. 2003. PAUP\* Phylogenetic Analysis using Parsimony (\*and other methods). Sinauer Associates, Sunderland, Massachusetts.
- Tatchell, R. J. and E. Easton. 1986. Tick (Acari: Ixodidae) ecological studies in Tanzania. *Bulletin of Entomological Research*, 76, 229-246.
- Thompson, J.D., T.J. Gibson, F. Plewniak, F. Jeanmougin and D.G. Higgins. 1997. The ClustalX windows interface: flexible strategies for multiple sequence alignment aided by quality analysis tools. *Nucleic Acids Research*, 25, 4876-4882.
- Walker, J.B., J.E. Keirans and I.G. Horak. 2000. Section 7 (pp59-316). Accounts of individual species occurring in the Afrotropical regions *In: The Genus Rhipicephalus (Acari: Ixodidae): A guide to the Brown Ticks of the world*, pp 643. Cambridge University Press.





**Chapter 6 - CORRELATING GENETIC AND  
ECOLOGICAL VARIATION IN *RHIPICEPHALUS*  
*APPENDICULATUS* FROM ZAMBIA WITH  
*R. APPENDICULATUS* FROM EASTERN AND SOUTHERN  
AFRICA**

**Based on the Manuscript:**

Jupiter Mtambo, Maxime Madder, Wim Van Bortel, Dirk Geysen, Dirk Berkvens and Thierry Backeljau. 2007. Genetic variation in *Rhipicephalus appendiculatus* (Acari: Ixodidae) from Zambia: Correlating genetic and ecological variation with *Rhipicephalus appendiculatus* from east and southern Africa. *Journal of Vector Ecology*, 32, 168-175.

## 6.1 Introduction

The African brown ear tick *Rhipicephalus appendiculatus* Neumann, 1901, is the main field vector of the haemoprotozoan parasite *Theileria parva*, the causative agent of East Coast fever (ECF). East Coast fever is one of the most economically important cattle diseases in Zambia (Makala *et al.*, 2003) and other east, central and southern African countries due to the high mortality, morbidity and other production losses associated with the disease (Mukhebi *et al.*, 1992). The distribution of *R. appendiculatus* is not continuous but is limited by factors like the availability of suitable hosts, vegetation and climate (Norval *et al.*, 1992a; Walker *et al.*, 2000). In addition, climate influences the number of generations per year (Norval *et al.*, 1992b).

Based on the number of generations per year, the adult body size and the expression or non-expression of a behavioural diapause (the suppression of host seeking activity in unfed adult ticks), *R. appendiculatus* have been divided into three groups (Madder *et al.*, 1999; Madder *et al.*, 2002 ; Speybroeck *et al.*, 2004 ). The first group comprises *R. appendiculatus* stocks that cycle through two or more generations per year originating from parts of east Africa e.g. Kenya, Rwanda, Burundi, Tanzania and Uganda where the climate is characterised by short dry seasons and high ambient humidity throughout most of the year (Smith, 1969a; Smith, 1969b; Tatchell and Easton, 1986; Kaiser *et al.*, 1988). The ability of the east African stocks to cycle through more than one generation per year has been attributed to the absence of a long dry season which precludes the necessity for a behavioural diapause (Berkvens *et al.*, 1995; Madder *et al.*, 2002) in these stocks. Further, climate, as it is influenced by latitude, has an effect on the adult body size of some insects (James *et al.*, 1995; Silver and Renshaw, 1999) and seems to be the case for *R. appendiculatus* (Speybroeck *et al.*, 2004). The latter authors have described east African stocks to be of smaller adult body size than southern African stocks.

The southern African stocks (i.e. stocks from Southern province of Zambia through Zimbabwe to South Africa) constitute the second group (Madder *et al.*, 2002; Speybroeck *et al.*, 2004). The climate of southern Africa is marked by a well defined rainy season which is followed by a dry season of almost equal duration. *Rhipicephalus appendiculatus* in this region cycles through one generation with peak adult activity coinciding with the rainy season (Short and Norval, 1981; Minshull and

Norval, 1982; Paine, 1982; Pegram *et al.*, 1986; Pegram and Banda, 1990; Speybroeck *et al.*, 2002). Southern African stocks exhibit either an obligatory or a very intense, photoperiod-induced (short day) behavioural diapause (Pegram and Banda, 1990; Norval *et al.*, 1991; Madder *et al.*, 2002) that allows them to delay oviposition until conditions favourable for the survival of eggs and larvae, the most vulnerable stages of their life cycle, are present. Termination of behavioural diapause in these stocks is determined by ageing (Southern province of Zambia) or in the case of Zimbabwe increasing photoperiod (Madder *et al.*, 2002). A comparatively larger adult body size in southern African stocks has been associated with the ability to survive harsh conditions (higher temperature, low ambient humidity and delayed feeding) during diapause (Speybroeck *et al.*, 2004).

The third group consists of *R. appendiculatus* stocks from the Eastern province of Zambia whose ecology has been described as “transition” between east and southern African stocks (Chaka *et al.*, 1999; Madder *et al.*, 1999; Speybroeck *et al.*, 2004) based on the following observations: (a) *R. appendiculatus* stocks from the Eastern province of Zambia have an average adult body size that is intermediate between that of *R. appendiculatus* from east and southern Africa (Speybroeck *et al.*, 2004), (b) their phenology is characterised by two adult activity periods per year (Berkvens *et al.*, 1998; Chaka *et al.*, 1999) in spite of a climate that is marked by well defined alternate rainy and dry seasons of approximately equal duration, and (c) their expression of behavioural diapause is mixed i.e. ticks may or may not enter behavioural diapause depending on the amounts of rain or length of the rainy season (Madder *et al.*, 2002). Diapause in the Eastern province stocks is terminated by ageing (Madder *et al.*, 2002). Recently Mtambo *et al.* (2007a) and Mtambo *et al.* (2007b) have shown that *R. appendiculatus* from Eastern and Southern provinces of Zambia are geographically genetically differentiated.

The aims of the current work were two-fold: (1) to clarify the phylogenetic relationship of the two geographic genetically differentiated stocks of *R. appendiculatus* from Southern and Eastern provinces that are ecologically classified as “southern African” and “transition” respectively with those of east and southern Africa in general and; (2) to compare the resultant phylogenetic relationships with the three group ecological characterization i.e. east African, transition (Eastern province of Zambia) and southern African stocks.

## 6.2 Materials and Methods

*Rhipicephalus appendiculatus* were collected from Zambia, Rwanda, Grande Comore, Zimbabwe and South Africa. Adults of *R. appendiculatus* stocks from Zambia from Southern and Eastern provinces were collected from cattle in 1997 and 2003, respectively. Southern province tick collections were from the plateau districts of Mazabuka (15°52' 0S, 27°46'0E) and Monze (16°16'60S, 27°28'60E) and the valley areas of Gwembe (16°49'0S, 27°46'60E), Livingstone (17°49'60S, 25°23'60E) and Sinazongwe (17°7'60S, 27°25'0E) districts. Ticks collected from the Southern province were killed in 70% ethanol immediately after collection. They were preserved in 70% ethanol in sealed vacutainer tubes at ambient temperatures. In Eastern province ticks were collected from the plateau districts of Chipata (13°37'60S, 32°38'60E) and Petauke (14°15'0S, 31°19'60E) and Nyimba (14°33'0S, 30°49'60E) a district on the fringes of the eastern province plateau and the Luangwa valley. These ticks were preserved at -80°C. In Rwanda, ticks were collected from cattle in different agro-ecological regions of the country in the districts of Byumba, Kibuye, Gitarama, Gikongoro, Kigali and Kibungo in 2004. These ticks were killed in 70% ethanol immediately upon capture. Later they were washed in tap water, air dried and packed in Ziplock bags with silica gel and preserved at 4°C. Ticks from South Africa were collected from cattle in Rietvlei (29°10'60S, 30°16'60E) and Hluhluwe (28°08'S, 32°09'60E) in the KwaZulu Natal midlands in 2000 and 2004, respectively. These specimens were killed and preserved in 70% ethanol. The ticks from Grande Comore were collected from cattle in May 2004 at Madjeouéni (11°49'18S, 43°16'41E) on the north-eastern part of the island. They were killed and preserved in 70% ethanol. Ticks from Zimbabwe were collected from cattle in West Mashonaland in 2000. They were left to die naturally after collection, dried and then stored in sealed conical tubes at ambient temperature. Different stocks were subjected to different preservation methods appropriate to the specific purposes for which they were collected other than this work.

DNA was isolated using the method of Boom *et al.* (1990, 1999). The primers, PCR conditions and temperature profiles used for amplification of the ITS2 and the COI including the sequencing techniques have been described by Mtambo *et al.* (2006). Mitochondrial 12S rDNA was amplified with the primers SR-J-1499 (5'-TACTATGTTACGACTTAT-3') and SR-N-14594 (5'-

AAACTAGGATTAGATACCC -3') (Simon *et al.*, 1994). The PCR conditions and thermal cycler temperature profile for amplification of the 12S rDNA were identical to those used in the amplification of the COI (Mtambo *et al.*, 2006). To distinguish between *R. appendiculatus* and the morphologically very closely related *Rhipicephalus zambeziensis* Walker, Norval and Corwin, 1981, a PCR-RFLP technique (Mtambo *et al.*, 2007b) was used. Briefly ITS2 amplicons of the specimens were digested with the restriction endonuclease *BauI* in a 25 $\mu$ L volume containing 17  $\mu$ L MqW, 2.5  $\mu$ L 10X buffer (Tango™), 0.5  $\mu$ L Enzyme (0.1U; *BauI*), and 5  $\mu$ L amplicon. The mixture was incubated at 37°C for 150 min. Fragment profiles were resolved by electrophoresis through 2% (w/v) agarose gel at 100 volts for 30 min and visualized after staining for 30 min in ethidium bromide.

Multiple alignments were generated for 59 (ITS2), 59 (COI) and 58 (12S rDNA) gene sequences using default options in ClustalX 1.83 (Thompson *et al.*, 1997). The alignments were imported into Genedoc ver.2.6.001 (Nicholas and Nicholas, 1997), wherein they were visually examined and redundant sequences were removed. The remaining sequences were subjected to a BLAST to confirm the target gene segment. These sequences were then aligned together with sequences of *Rhipicephalus turanicus* Pomerantsev, 1936 (accession numbers **DQ849267** [ITS2]; **DQ849231** [12S rDNA]; **DQ859260** [COI]) as the outgroup species. These alignments are available in the EMBL-Align database under the accession numbers: **ALIGN\_001066**=ITS2; **ALIGN\_001067**=COI; **ALIGN\_001065**=12S rDNA. The best models of evolution for the sequences of the three target genes were determined in Modeltest (Posada and Crandall, 1998) using the Akaike Information Criteria. Modeltest chose the General Time Reversible with a proportion of invariable sites (GTR+I) as the model best fitting the COI data with the following model parameters: base frequencies; freqA = 0.2755, freqC = 0.1832, freqG = 0.1376 and freqT = 0.4037; Rmat=1.7849, 3.4740, 3.7650, 0.1735 and 10.8297; Rates=equal and proportion of invariable sites (I) =0.6340. For the ITS2 data the GTR model with no invariable sites was the most appropriate. The parameters of the model were: base frequencies; freqA = 0.1839, freqC = 0.3016, freqG = 0.3487 and freqT = 0.1658; Rmat =0.9242, 1.5422, 1.3804, 0.3855 and 3.3218; Rates=equal and Pinvar (I) =0. The model best fitting the 12S rDNA was the K81uf+I. This model had the following parameters: base frequencies; freqA= 0.3658, freqC= 0.1178, freqG= 0.0916 and

freqT= 0.4248; Rmat= 1.0000, 2003660.7500, 1123197.3750, 1123197.3750 and 2003660.7500; Rates=equal and Pinvar (I) = 0.7203.

Phylogenetic relationships among the ITS2 sequences and COI and 12S rDNA haplotypes were evaluated by both a distance (NJ: Neighbour-joining) and a maximum likelihood (ML) analysis in PAUP\* (Swofford, 2003). Starting trees were obtained through random addition of input taxa with the heuristic search option and tree bisection-reconnection (TBR) branch swapping. In all the analyses gaps were treated as missing data. The reliability of the groups on the trees was evaluated through bootstrap analysis with 1,000 iterations with TBR branch swapping.

### 6.3 Results

Targeted genes failed to amplify in the dried *R. appendiculatus* material from Zimbabwe. The ones that amplified did not give interpretable sequences. Instead we obtained ITS2 (Accession No. **U97704**) and COI (Accession No. **AF132833**) sequences for Zimbabwe from GenBank. These and the rest of the sequences used in this study are summarised in Table 6.1. Sequences for the ITS2 and the two mitochondrial (COI and 12S rDNA) fragments obtained for *R. appendiculatus* material from Rwanda and Grande Comore appear in GenBank under accession numbers **DQ901321-DQ901355** for the ITS2, **DQ901356-DQ901363** for COI and **DQ901277-DQ901320** for 12S rDNA. Ticks from Zambia and South Africa appear in GenBank under the following accession numbers: ITS2= (**DQ849239-DQ849254** and **DQ849269-DQ849272**); 12S rDNA= (**DQ849203-DQ849218** and **DQ849233-DQ849236**); COI= (**DQ859261-DQ859266**). Specimens were submitted to the Royal Belgium Museum of Natural sciences under the General Inventory number **I.G. 30662**

There were five different ITS2, eight COI and five 12S rDNA sequences (Tables 6.2-6.4). The Eastern province had five COI and 12S rDNA haplotypes compared to one in both segments in the Southern province. The Eastern province and Rwanda shared some COI and 12S rDNA haplotypes. In addition COI and 12S rDNA haplotypes endemic to either Rwanda or the Eastern province but sympatric to the shared haplotypes were observed.

**Table 6.1: Source and numbers of *R. appendiculatus* sequences for the three gene segments analysed**

Country	Gene Segment	No. of Sequences
Rwanda	ITS2	15
	COI	15
	12S rDNA	15
Grande Comore	ITS2	2
	COI	2
	12S rDNA	2
Zambia	ITS2	35
	COI	35
	12S rDNA	35
Zimbabwe	ITS2	1
	COI	1
	12S rDNA	0
South Africa	ITS2	6
	COI	6
	12S rDNA	6

Results of the analysis of the ITS2 data did not provide support for grouping *R. appendiculatus* from Rwanda, Zambia (Eastern and Southern provinces) and South Africa into any special groupings. The COI tree had two well-supported groups (fig. 6.1). One group (BS values of 95 % [ML] and 100 % [NJ]) was an unresolved polytomy of Eastern province plateau and Rwanda haplotypes within which there is weak support (BS values 64 % [ML] and 67 % [NJ]) for the exclusion of Eastern province plateau haplotype 8. The second group had BS values of 70 % [ML] and 98 % [NJ]. This group comprised ticks from South Africa, Zimbabwe, Zambia (Southern province and the south west edges [Nyimba] on the Eastern province plateau) and Grande Comore. The 12S rDNA tree (fig. 6.2) was resolved into two groups (BS values 78 % [NJ] and 87% [ML]). One group consisted of Eastern province (Nyimba), Southern province of Zambia, South Africa and Grande Comore stocks while the second was made up of stocks from Rwanda and Eastern province plateau districts.

**Table 6.2: Variation of the ITS2 sequences in *R. appendiculatus* from six east, central and southern African countries**

Sequence No.	Number of Sequences	Variable Base Positions														Sequence Origin	
		34	135	346	364	400	408	445	509	510	606	755	788	850	1003		1006
Sequence 1	2	T	C	A	T	C	C	C	-	-	C	T	A	T	A	C	Zambia (East & South)
Sequence 2	26	-	-	-	-	-	-	T	-	-	-	-	-	-	-	-	Zambia (East & South), South Africa
Sequence 3	1	-	-	T	-	T	T	C	T	-	T	A	-	-	-	-	Zimbabwe (McIlwaine)
Sequence 4	25	-	C	A	T	C	C	T	-	-	C	G	T	T	-	-	Rwanda and Zambia (East)
Sequence 5	5	T	-	-	-	-	-	-	-	-	-	T	-	-	-	C	Grande Comore, Zambia(South), South Africa

Key: ▫ indel; — nucleotide identical to one immediately above, Zambia (South); Southern province of Zambia, Zambia (East); Eastern province of Zambia, Zambia (East & South); both Eastern and Southern provinces of Zambia.

**Table 6.3: Variation of the COI sequences in *R. appendiculatus* from five east, central and southern African countries**

HAPLOTYPE	No. of specimens	VARIABLE BASE POSITIONS																				SOURCES	
		12	24	57	94	147	159	165	211	240	246	261	303	315	339	345	372	393	394	432	453		465
Haplotype 1	30	T	G	T	C	T	C	T	A	G	C	T	A	T	T	G	T	A	G	G	C	C	Zambia (South and East), Zimbabwe, South Africa
Haplotype 2	2	-	-	C	-	-	-	-	-	-	-	-	-	-	-	-	-	-	-	-	-	-	Grande Comore
Haplotype 3	19	C	-	-	T	C	T	-	-	-	T	-	G	C	-	A	G	A	G	A	T	T	Zambia (East), Rwanda
Haplotype 4	1	-	-	-	-	-	-	-	-	-	-	-	-	-	-	-	-	-	A	-	-	-	Zambia (East)
Haplotype 5	1	-	-	-	-	-	-	C	-	-	-	-	-	-	-	-	-	-	G	-	-	-	Zambia (East)
Haplotype 6	1	-	-	-	-	-	-	-	A	-	-	-	-	-	-	-	-	-	G	-	-	-	Rwanda
Haplotype 7	1	-	-	-	-	-	C	-	A	-	-	-	-	-	-	-	-	-	A	-	-	-	Rwanda
Haplotype 8	4	-	-	-	-	-	T	-	G	-	-	-	-	-	-	-	-	-	-	-	G	-	Zambia (East)

Key: — nucleotide identical to one immediately above, Zambia (South); Southern province of Zambia, Zambia (East); Eastern province of Zambia, Zambia (East & South); both Eastern and Southern provinces of Zambia.

**Table 6.4: Variation of the 12S rDNA sequences in *R. appendiculatus* from five east, central and southern African countries**

Haplotype	Number of Sequences	Variable Base Positions						Haplotype location	
		69	81	88	164	220	309		315
Haplotype 1	33	T	T	T	T	G	G	A	Grande Comore, Zambia (East & South), South Africa
Haplotype 2	4	C	C	C	-	-	-	-	Zambia (East)
Haplotype 3	1	-	T	-	-	-	-	-	Zambia (East)
Haplotype 4	2	-	-	-	-	-	-	G	Rwanda and Zambia (East)
Haplotype 5	18	-	-	-	-	-	-	A	Rwanda and Zambia (East)



Key: “▪” indel (insertion deletion event), “–” “nucleotide same as one immediately above, Zambia (South); Southern province of Zambia, Zambia (East); Eastern province of Zambia, Zambia (East & South); both Eastern and Southern provinces of Zambia.

## 6.4 Discussion

The non-resolution of *R. appendiculatus* from Rwanda, Zambia, Zimbabwe and South Africa into any special groups by the current ITS2 data show that in spite of their ecological differences *R. appendiculatus* from Rwanda (east Africa), Zambia, Zimbabwe and South Africa (southern Africa) are one and the same species. However, the mitochondrial (12S rDNA and COI) DNA data show that, *R. appendiculatus* from Rwanda, Zambia, Zimbabwe and South Africa may be divided into two geographic genetically differentiated groups: (1) a group consisting of specimens from Rwanda and the plateau districts of the Eastern province of Zambia which we here refer to as the “east African genetic group (eAGG)” and, (2) a group comprising specimens from South Africa, Zimbabwe, Grande Comore, the Southern province of Zambia and the south western edges of the Eastern province plateau (Nyimba) in Zambia, which we have referred to as the “southern African genetic group (sAGG)” (fig.6.1 and 6.2). This geographic genetic differentiation into sAGG and eAGG is an indicator of possible temporal and/or spatial partial isolation of the two populations (Avise, 2000).

That the stocks from Eastern province that are considered transitional and stocks from Rwanda form a coherent monophyletic eAGG is at variance with their ecological groupings. The difference in ecology within the eAGG may be due to genetic polymorphism and or phenotypic plasticity. Eastern province transition stocks had five COI and 12S rDNA haplotypes respectively (compared to a single haplotype for both segments in all the southern African stocks). It is possible that some haplotypes may be favoured by the local conditions obtaining in one area more than in others, e.g. a shorter rainy season for Eastern province than most places in Rwanda or east Africa in general may be favourable to some haplotypes and not others. Which haplotype corresponds to a particular phenotype or phenotypes (size, diapause and phenology) under discussion cannot be ascertained with the current data.

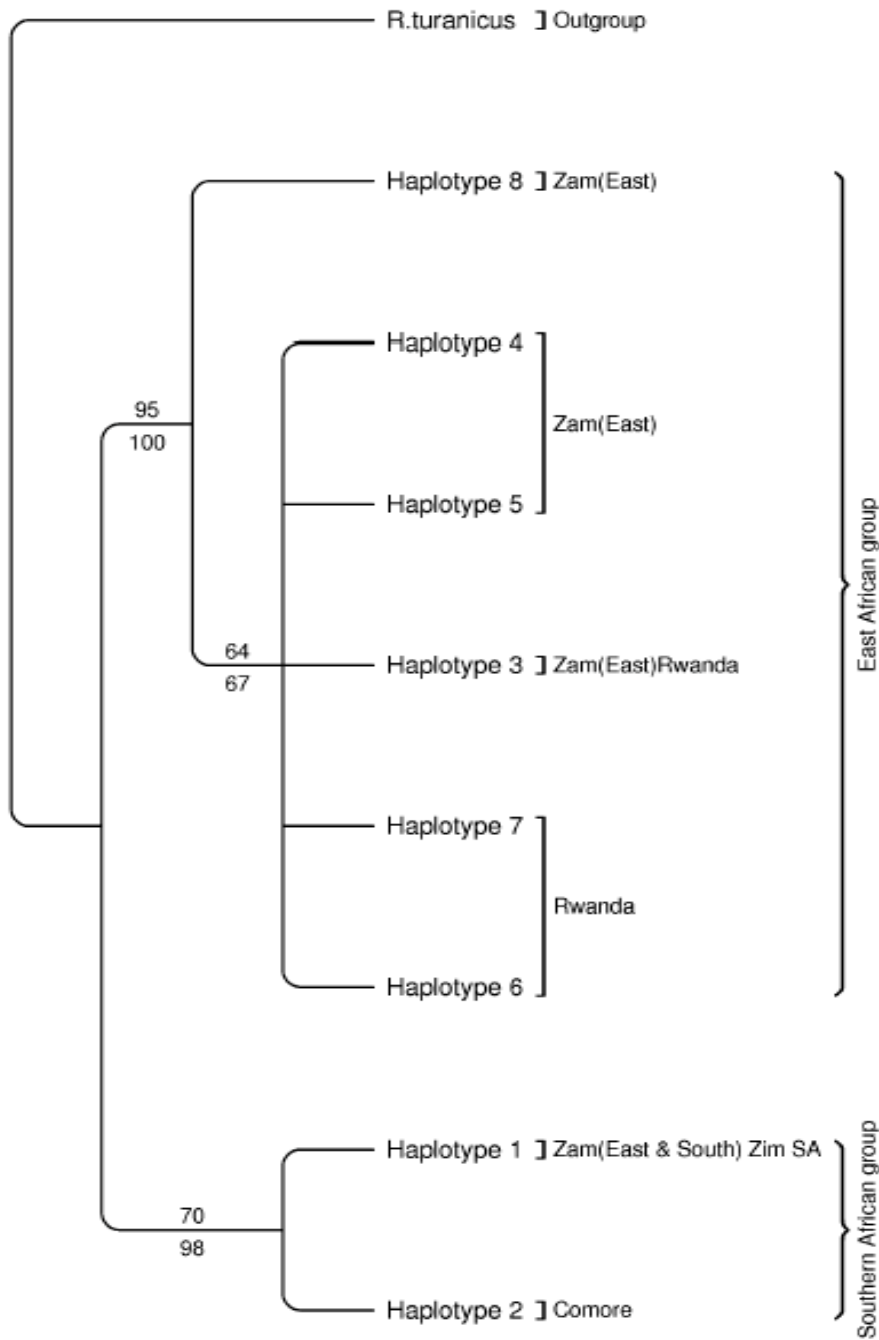

**Figure 6.1: A cladogram of COI haplotypes with Bootstrap support values; Top = ML; Bottom = Neighbour Joining (NJ); Names after the braces refer to the area where haplotypes were found. SA=South Africa; Zam (south) = Southern province of Zambia; Zam (east) = Eastern province of Zambia; Zam (East & South) = Eastern and Southern province of Zambia; Zim= Zimbabwe; Comore= Grand Comore**

It is also possible that individuals of the same haplotype may have varied phenotypic expression of their genotype in different environmental conditions. Indeed the most prevalent haplotypes i.e. COI haplotype 3 and 12S rDNA haplotype 5, were common to both Rwanda and the Eastern province. Similarly the reported difference in body size (Speybroeck *et al.*, 2004) in stocks arising from the same regions as those that constituted our eAGG may be attributed to genetic polymorphism, phenotypic plasticity, differences in latitude (Speybroeck *et al.*, 2004) and or any other unidentified local factors (Speybroeck *et al.*, 2004). Madder *et al.* (1999) studying diapause induction in three stocks of ticks from Kiambu (Kenya), Mtenguleni (Eastern province Zambia) and West Mashonaland (Zimbabwe) speculated the existence of an extensive genetic variation for diapause after observing as many responses as were the stocks. We however suggest that an extensive genetic variation for diapause might exist especially within the eAGG.

The composition of the sAGG agrees with the ecological similarities of the constituent stocks (Norval *et al.*, 1991; Madder *et al.*, 1999; Speybroeck *et al.*, 2004) except for Grande Comore ticks for which no prior ecological information was obtained. However, the Island of Grande Comore has a single rainy season (November to April) and a dry season of equal duration (May to October) with temperatures ranging from 20-28°C (Ben Daoud and Scheltens 1985). Such climatic conditions could be more favourable to the establishment of *R. appendiculatus* that express a behavioural diapause in order to synchronize oviposition with favourable environmental conditions (Speybroeck *et al.*, 2004). However, the actual situation in Grande Comore can only be established by further surveys as local ecological conditions may modulate these climatic conditions.

The failure of amplification of dried specimens from Zimbabwe may have been due to the nature of the killing and storage methods (Mtambo *et al.*, 2006).

Within the limits of this data we conclude that *R. appendiculatus* stocks from Southern and Eastern provinces of Zambia are geographically genetically differentiated stocks that might be part of two wider geographically genetically differentiated populations of *R. appendiculatus* in which Southern province stocks are part of the sAGG and the Eastern province stocks belong to the eAGG. It will be important to delimit the ranges of these two groups both within and outside Zambia

since their respective roles in the epidemiology of ECF may be different (McLain *et al.*, 1995; Avise, 2000; Speybroeck *et al.*, 2004).

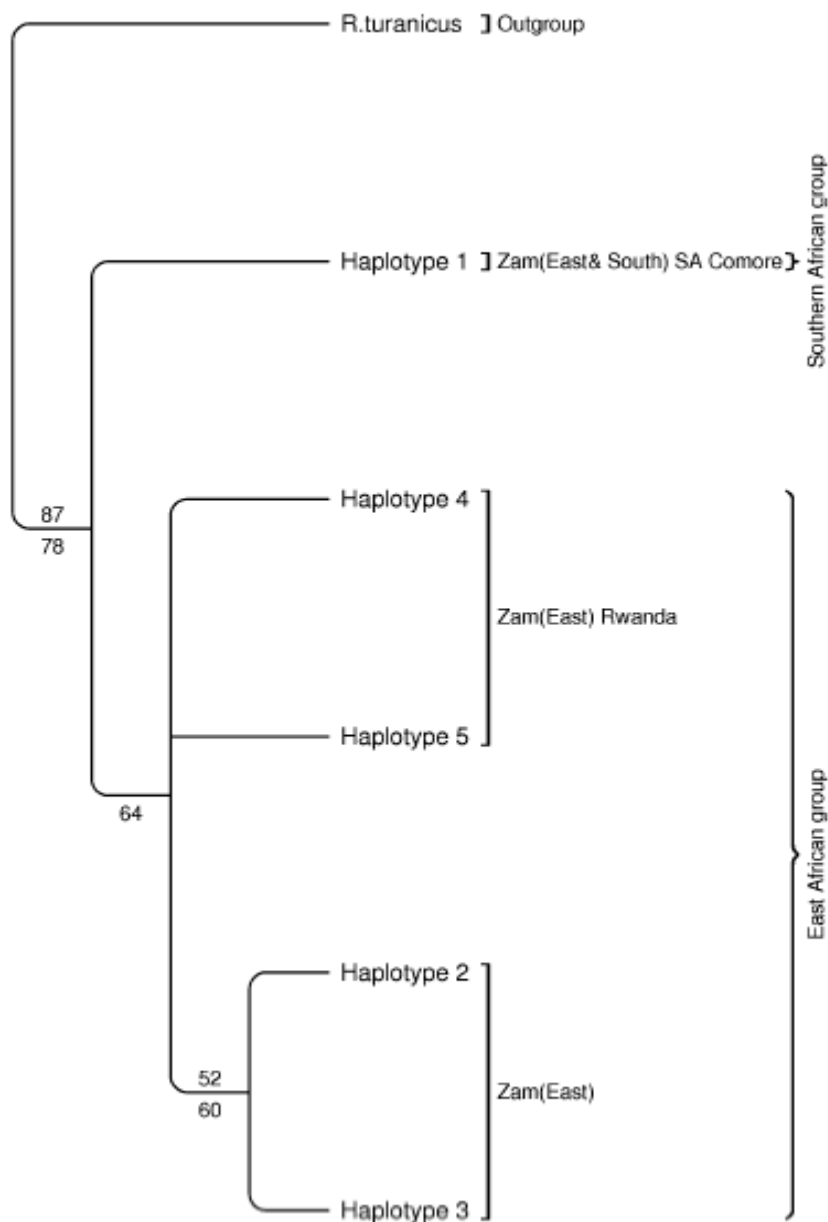

**Figure 6.2: A cladogram of 12S rDNA sequences with Bootstrap support values; Top = ML, Bottom= Neighbour Joining. Names after the braces refer to the area where haplotypes were found. SA=South Africa; Zam (south) = Southern province of Zambia; Zam (east) = Eastern province of Zambia; Zam (East & South) = Eastern and Southern province of Zambia; Comore= Grand Comore**

## 6.5 References

- Avise, J.C. 2000. Phylogeography: The history and formation of species. Harvard University Press, Cambridge and London.
- Ben Daoud, A. and E.B. Scheltens. 1985. Vegetable farming in the Comores; problems and prospects. *Acta Hort. (ISHS)* 153:109-114.
- Berkvens, D.L., R.G. Pegram and J.R.A. Brandt. 1995. A study of the diapausing behaviour of *Rhipicephalus appendiculatus* and *R. zambeziensis* under quasi-natural conditions in Zambia. *Medical and Veterinary Entomology*, 9, 307-315.
- Berkvens, D.L., D.M. Geysen, G. Chaka, M. Madder and J.R.A. Brandt. 1998. A survey of the ixodid ticks parasitizing cattle in the Eastern province of Zambia. *Medical and Veterinary Entomology*, 12, 234-240.
- Boom, R., C.J.A. Sol, M.M.M. Salimans, C.L. Jansen, P.M.E. Wertheim-van Dillen and J. Van Der Noordaa. 1990. Rapid and simple method of purification of nucleic acids. *Journal of Clinical Microbiology*, 28, 495-503.
- Boom, R., C. Sol, M. Beld, J. Weel, J. Goudsmit and P. M. E. Wertheim-van Dillen. 1999. Improved silica-guanidiniumthiocyanate DNA isolation procedure based on selective binding of bovine alpha-casein to silica particles. *Journal of Clinical Microbiology*, 37, 615-619.
- Chaka, G., M. Billiouw, D. M. Geysen and D. L. Berkvens. 1999. Spatial and temporal variation in *Rhipicephalus appendiculatus* size in eastern Zambia. *Tropical Medicine and International Health*, 4, A43-A48.
- James, A. C., R.B.R. Azevedo and L. Partridge. 1995. Cellular basis and development timing in a size cline of *Drosophila melanogaster*. *Genetics*, 140, 659-666.
- Kaiser, M.N., R.W. Sutherst, A.S. Bourne, L. Gorissen and R.B. Floyd. 1988. Population dynamics of ticks on Ankole cattle in five ecological zones in Burundi and strategies for their control. *Preventive Veterinary Medicine*, 6, 199-222.
- Madder, M., N. Speybroeck, J. Brandt and D. Berkvens. 1999. Diapause induction in adults of three *Rhipicephalus appendiculatus* stocks. *Experimental and Applied Acarology*, 23, 961-968.
- Madder, M., N. Speybroeck, J. Brandt, L. Tirry, I. Hodek and D. Berkvens. 2002. Geographic variation in diapause response of adult *Rhipicephalus appendiculatus* ticks. *Experimental and Applied Acarology*, 27, 209-221.
- Makala L.H., P. Mangani, K. Fujisaki and H. Nagasawa. 2003. The current status of major tick borne diseases in Zambia. *Veterinary Research*, 34, 27-45.
- McLain, D.K., D.M. Wesson, J.H. Oliver Jr. and F.H. Collins. 1995. Variation in ribosomal DNA internal transcribed spacer 1 among Eastern populations of *Ixodes scapularis* (Acari: Ixodidae). *Journal of Medical Entomology*, 32, 353-360.

- Minshull, J.I. and R.A.I. Norval. 1982. Factors influencing the spatial distribution of *Rhipicephalus appendiculatus* in Kyle Recreational Park, Zimbabwe. South African Journal of Wildlife Research, 12, 118-123.
- Mtambo, J., W. Van Bortel, M. Madder, P. Roelants and T. Backeljau. 2006. Comparison of preservation methods of *Rhipicephalus appendiculatus* (Acari: Ixodidae) for reliable DNA amplification by PCR. Experimental and Applied Acarology, 38, 189-199.
- Mtambo, J., M. Madder, W. Van Bortel, D. Berkvens and T. Backeljau. 2007a. *Rhipicephalus appendiculatus* and *R. zambeziensis* (Acari: Ixodidae) from Zambia: a molecular reassessment of their species status and identification. Experimental and Applied Acarology, 41, 115-128.
- Mtambo, J., M. Madder, W. Van Bortel, D. Berkvens, G. Chaka and T. Backeljau. 2007b. Further evidence for geographic differentiation in *R. appendiculatus* (Acari: Ixodidae) from Eastern and Southern provinces of Zambia. Experimental and Applied Acarology, 41: 129-138.
- Mukhebi, A.W., B.D. Perry and R. Kruska. 1992. Estimated economics of theileriosis control in Africa. Preventive Veterinary Medicine, 12, 73-85.
- Nicholas, K.B. and H.B. Nicholas Jnr. 1997. GeneDoc: a tool for editing and annotating multiple sequence alignments. Distributed by author. <http://www.psc.edu/biomed/genedoc/gddl.htm>
- Norval, R.A.I., J.A. Lawrence, A.S. Young, B.D. Perry, T.T. Dolan and J. Scott. 1991. *Theileria parva*: influence of vector, parasite and host relationships on the epidemiology of theileriosis in southern Africa. Parasitology, 102, 347-356.
- Norval, R.A.I., B.D. Perry and A.S. Young. 1992a. Chapter 4 (pp 99-130). Tick Vectors of Theileriosis *In: The epidemiology of theileriosis in Africa*, pp 481. Academic Press, London.
- Norval, R.A.I., B.D. Perry and A.S. Young. 1992b. Chapter 6 (pp 155-180). Vector Population Dynamics *In: The epidemiology of theileriosis in Africa*, pp 481. Academic Press, London.
- Paine, G.D. 1982. Ticks (Acari: Ixodoidea) in Botswana. Bulletin of Entomological Research, 72, 1-16.
- Pegram, R.G., B.D. Perry, F.L. Muisi and B. Mwanaumo. 1986. Ecology and phenology of ticks in Zambia: seasonal dynamics on cattle. Experimental and Applied Acarology, 2, 25-45.
- Pegram, R.G. and D.S. Banda. 1990. Ecology and phenology of cattle ticks in Zambia: development and survival of free living stages. Experimental and Applied Acarology, 8, 291-301.
- Posada, D. and K.A. Crandall. 1998. Modeltest: testing the model of DNA substitution. Bioinformatics, 14, 817-818.
- Short, N. J. and R.A.I. Norval. 1981. The seasonal activity of *Rhipicephalus appendiculatus*, Neumann 1901 (Acarina: Ixodidae) in the highveld of Zimbabwe. Journal of Parasitology, 67, 77-84.

- Silver, J.B and M. Renshaw. 1999. Are mosquitoes from lower latitudes smaller? *Medical and Veterinary Entomology*, 13, 219-223.
- Simon, C., F. Frati, A. Beckenbach, B. Crespi, H. Liu and P. Flook. 1994. Evolution, weighting and phylogenetic utility of mitochondrial gene sequences and a compilation of conserved polymerase chain reaction primers. *Annals of the Entomological Society of America*, 87, 651- 701.
- Smith, M.W. 1969a. Variations in tick species and populations in the Bugisu district of Uganda part I. *Bulletin of Epizootic Diseases of Africa*, 17, 55-75.
- Smith, M.W. 1969b. Variations in tick species and populations in the Bugisu district of Uganda part II. *Bulletin of Epizootic Diseases of Africa*, 17, 77-105.
- Speybroeck, N., M. Madder, P. Van Den Bossche, J. Mtambo, N. Berkvens, G. Chaka, M. Mulumba, J. Brandt, L. Tirry and D. Berkvens. 2002. Distribution and phenology of ixodid ticks in southern Zambia. *Medical and Veterinary Entomology*, 16, 430-441.
- Speybroeck, N., M. Madder, H.H. Thulke, J. Mtambo, L. Tirry, G. Chaka, T. Marcotty and D. Berkvens. 2004. Variation in body size in the tick complex *Rhipicephalus appendiculatus/Rhipicephalus zambeziensis*. *Journal of Vector Ecology*, 29, 347-354.
- Swofford, D.L. 2003. PAUP\* Phylogenetic Analysis using Parsimony (\*and other methods). Sinauer Associates, Sunderland, Massachusetts.
- Tatchell, R. J. and E. Easton. 1986. Tick (Acari: Ixodidae) ecological studies in Tanzania. *Bulletin of Entomological Research*, 76, 229-246.
- Thompson, J.D., T.J. Gibson, F. Plewniak, F. Jeanmougin and D.G. Higgins. 1997. The ClustalX windows interface: flexible strategies for multiple sequence alignment aided by quality analysis tools. *Nucleic Acids Research*, 25, 4876-4882.
- Walker, J.B., J.E. Keirans and I.G. Horak. 2000. Section 7 (pp59-316). Accounts of individual species occurring in the Afrotropical regions *In: The Genus Rhipicephalus (Acari: Ixodidae): A guide to the Brown Ticks of the world*, pp 643. Cambridge University Press.





**Chapter 7 - INTRASPECIFIC VARIATION IN  
*RHIPICEPHALUS ZAMBEZIENSIS* FROM SOUTHERN  
PROVINCE BASED ON MITOCHONDRIAL 12S rDNA**

## 7.1 Introduction

*Rhipicephalus zambeziensis* Walker, Norval, & Corwin, 1981 and the morphologically closely related *Rhipicephalus appendiculatus* Neumann 1901, the field vectors of *Theileria parva* the causative organism of East Coast fever (ECF) (Norval *et al.*, 1992) have been recognised as tick species that are most important economically through out eastern and southern Africa.

The ecology of *R. zambeziensis* has been described (Norval *et al.*, 1982; Berkvens *et al.*, 1995; Madder *et al.*, 2005). The description has mostly been in comparison with the ecology of *R. appendiculatus* due to their morphological closeness and because the latter was the first to be described. As a rule *R. zambeziensis* is less widely distributed and is found in hotter and drier areas than *R. appendiculatus* (Norval *et al.*, 1982). Generally it has a smaller adult body size than *R. appendiculatus* and does not exhibit a behavioural diapause (Walker *et al.*, 1981; Berkvens *et al.*, 1995).

*Rhipicephalus zambeziensis* was first reported in Zambia as “specimens near *R. appendiculatus*” in the valleys of the Zambezi and Luangwa rivers (MacLeod, 1970; MacLeod *et al.*, 1977). More reports have since been made in areas outside the valleys (Zivkovic *et al.*, 1986; Mulumba *et al.*, 2001; Speybroeck *et al.*, 2002; Mtambo *et al.*, 2007a).

Stocks of *R. zambeziensis* from southern province, exhibit differences in morphology between specimens collected from the valleys and on the plateau. Specimens collected from the valleys have morphological features that are more consistent with the classical morphological description of the species, i.e. small adult body size, dark brown in colour, heavily punctate and a broad U-shaped genital opening in the case of females (JM unpublished observations). On their part, specimens collected on the plateau tend to be less punctate, larger with varied form of the female genital aperture between U- and V forms. Further, we have observed (JM and MM unpublished) and Fivaz and Norval (1989) have reported feeding *R. zambeziensis* from South Africa and Zimbabwe respectively on rabbits. To the contrary adult *R. zambeziensis* specimens from Zambia feed reluctantly or not all when fed on rabbits (unpublished observation). This could not be put down to diapause as this phenomenon is yet to be demonstrated in this species (Berkvens *et al.*, 1995).

In the current work we compared mitochondrial 12S rDNA (mt12S rDNA) sequences for a collection of *R. zambeziensis* specimens from the valley, Livingstone and Plateau regions of the Southern province of Zambia for geographical and ecological differentiation in the presence of *R. appendiculatus* from Rietvlei (South Africa) as control stocks.

## **7.2 Materials and Methods**

### **7.2.1 Study Area**

The Southern province of Zambia is situated between longitudes 25°01'-28°40'E and latitudes 15°14' -17°42'S. Mitochondrial 12S rDNA sequences of ticks collected from three ecological regions i.e. the plateau (Keemba and Nteme) ( $\pm$  1200m), valley (Sinafala, Syabwengo and Mamba) (<1000m) and Livingstone (Simango) (<1000m) regions were obtained from earlier work (Mtambo *et al.*, 2007a). Livingstone is a valley region but the presence of the Victoria Falls confers a special microclimate of high humidity on the area (Speybroeck *et al.*, 2002). Also obtained were mt 12S rDNA sequences of *R. zambeziensis* from Rietvlei (29°10'60S, 30°16'60E) South Africa.

### **7.2.2 DNA sequences**

Five mt12S rDNA sequences representing five individual tick specimens were obtained for each of the three ecological areas of Zambia while six sequences of six individual specimens were obtained for Rietvlei South Africa. Finally a sequence each of *R. appendiculatus* from South Africa and Nkonkola, Zambia were obtained for use as outgroup species in the phylogenetic analysis. DNA extraction, amplification, sequencing and other molecular methods were described elsewhere (Mtambo *et al.*, 2006; Mtambo *et al.*, 2007a). GenBank submission numbers for these sequences are DQ849219 to DQ849228, DQ849238, DQ849205 and DQ849235.

### **7.2.3 Alignment and phylogenetic analysis**

Multiple alignments were generated in CLustalX 1.83 (Thompson *et al.*, 1997) using default settings. They were visualized and manually edited in GENEDOC (Nicholas and Nicholas, 1997) and redundant sequences were excluded. Using the program Modeltest (Posada & Crandall, 1998) the best fit model of evolution for the aligned 12s rDNA sequences was determined as K81uf (Kimura, 1981 with unequal base frequencies) based on the Akaike information criteria. Using the parameters of the

model maximum likelihood and distance (NJ= Neighbour Joining) analyses were performed with *R. appendiculatus* from Nkonkola (Zambia) and Rietvlei (SA) as outgroup species in PAUP\* version 4.0b10 (Swofford, 2003). Starting trees were obtained through random addition of input taxa with the heuristic search option and tree bisection-reconnection (TBR) branch swapping. Gaps were treated as missing data. The reliability of groups on the trees was assessed through bootstrap analysis by 1000 iterations with TBR branch swapping.

### **7.3 Results**

Phylogenetic assessment of their relationships did not show support for differentiation in any groups. The highest number of haplotypes per village was observed in the valley region where Maamba and Syabwengo villages had four haplotypes each (Table 7.1). Haplotype 2 was ubiquitous in all three ecological areas of southern Zambia. Rietvlei (SA) had a single haplotype i.e. haplotype 8.

**Table 7.1: Alignment of mitochondrial 12S rDNA for *R. zambeziensis* from South Africa and from villages falling under three ecological regions (valley, plateau and Livingstone\*) of southern Zambia**

HAPLOTYPE	No. OF SPECIMENS	VARIABLE BASE POSITIONS							Source	
		88	105	111	133	181	245	357	Village	Region
Haplotype 1	3	T	T	A	A	T	A	C	Keemba	Plateau
Haplotype 2	15	T	T	A	T	T	A	C	Nteme, Kemba, Sinafala, Maamba, Syabwengo, Simango	Plateau/valley/Livingstone
Haplotype 3	4	T	T	T	T	T	A	C	Mamba, Sinafala, Syabwengo	Valley
Haplotype 4	1	T	T	A	T	T	G	C	Mamba.	Valley
Haplotype 5	1	T	T	A	T	T	A	T	Syabwengo	Valley
Haplotype 6	2	T	T	A	T	C	A	C	Simango	Livingstone
Haplotype 7	4	T	C	A	T	T	A	C	Mamba, Syabwengo	Valley
Haplotype 8	6	A	T	A	T	T	A	C	Rietvlei	SA

\* See text for explanation of Livingstone as an ecological area

## 7.4 Discussion

Variation in the 12S mtrDNA did not reveal any particular ecological or regional patterning within the Southern province stocks and neither was there a geographical pattern between Southern province and the SA reference stock. The absence of an ecological /regional patterning within the Southern province could be a result of high inter-regional dispersal of the tick due to high host vagility brought about by human activity (Mtambo *et al.*, 2007b.) Ordinarily, however, high dispersal should lead to uniformity of the haplotypes due to increased gene flow (Avice, 2000a). This seems to be the case for *R. appendiculatus* from the same ecological areas that had only one 12S rDNA haplotype (Mtambo *et al.*, 2007a). Instead *R. zambeziensis* had seven haplotypes and whose distribution was near haphazard. This high and random variation of haplotypes may be due to what has been called high variances in reproductive success (Avice, 2000a). This is because the valleys in which *R. zambeziensis* is confined are characterized by highly variable seasonal rain patterns. These result in high variation in reproductive success of *R. zambeziensis* between drought and the good rainy year. The same explanation can be used for the higher number of haplotypes of *R. zambeziensis* observed in the valley regions compared to the plateau regions.

The stocks from South Africa had a single haplotype unique to that region at least with the current data. The existence of intervening populations of *R. zambeziensis* in Zimbabwe that were not included in this study prevents us to make any major conclusions. However, for the difference in feeding behaviour we speculate this could be a case of character displacement (Moynihan, 1968) where sibling species differ more in places where their ranges overlap (due to ecological competition) than in allopatry. Meaning *R. zambeziensis* and *R. appendiculatus* are more different, in as far as feeding behaviour is concerned, in Zambia (where their ranges overlap over bigger areas (Zivkovic *et al.*, 1986)) than in South Africa.

In conclusion, current 12S mtrDNA shows that there is no ecological differentiation in southern province stocks. The data further shows that the Southern province and South African stocks might not be geographically genetically differentiated. Therefore the phenotypic differences within the Southern province of Zambia stocks and between the Zambian and South African stocks are most likely due to climate and

other environmental and local factors. However, some of these differences are quite confounding. For example *R. zambeziensis* from South Africa (higher latitude) is smaller than that from Zambia (lower latitude) though the difference is not significant (Speybroeck *et al.*, 2004). There is need to investigate the apparent difference in feeding behaviour between South African and Zambian *R. zambeziensis* stocks using stocks from Zambia, Zimbabwe and South Africa.

## 7.5 References

- Avise, J.C. 2000. Chapter 2 (pp 37-108). Demography-Phylogeny connections *In*: Phylogeography: The history and formation of species, pp447. Harvard University Press, Cambridge and London.
- Berkvens, D.L., R.G. Pegram and J.R.A. Brandt. 1995. A study of the diapausing behaviour of *Rhipicephalus appendiculatus* and *R. zambeziensis* under quasi-natural conditions in Zambia. *Medical and Veterinary Entomology*, 9, 307-315.
- Fivaz, B.H. and A. Norval. 1989. Observations on successive infestations of the rabbit host by the ticks *Rhipicephalus appendiculatus* and *R. zambeziensis* (Acari: Ixodidae). *Experimental and Applied Acarology*, 7, 267-269.
- MacLeod, J. 1970. Tick infestation in the southern province of Zambia. *Bulletin of Entomological Research*, 60, 253-274.
- MacLeod, J., M.H. Colbo, M.H. Madbouly and B. Mwanaumo. 1977. Ecological studies of ixodid ticks (Acari, Ixodidae) in Zambia III. Seasonal activity and attachment sites on cattle with notes on other hosts. *Bulletin of Entomological Research*, 67, 161-173.
- Madder, M., N. Speybroeck, A. Bilounga, D. Helleputte and D. Berkvens. 2005. Survival of unfed *Rhipicephalus appendiculatus* and *Rhipicephalus zambeziensis* adults. *Medical and Veterinary Entomology*, 19, 245-250.
- Moynihan, M. 1968. Social mimicry: character convergence versus character displacement. *Evolution*, 22, 315-331.
- Mtambo, J., W. Van Bortel, M. Madder, P. Roelants and T. Backeljau. 2006. Comparison of preservation methods of *Rhipicephalus appendiculatus* (Acari: Ixodidae) for reliable DNA amplification by PCR. *Experimental and Applied Acarology*, 38, 189-199.
- Mtambo, J., M. Madder, W. Van Bortel, D. Berkvens and T. Backeljau. 2007a. *Rhipicephalus appendiculatus* and *R. zambeziensis* (Acari: Ixodidae) from Zambia: a molecular reassessment of their species status and identification. *Experimental and Applied Acarology*, 41, 115-128.
- Mtambo, J., M. Madder, W. Van Bortel, D. Berkvens, G. Chaka and T. Backeljau. 2007b. Further evidence for geographic differentiation in *R. appendiculatus* (Acari: Ixodidae) from Eastern and Southern provinces of Zambia. *Experimental and Applied Acarology*, 41, 129-138.
- Mulumba, M., N. Speybroeck, D.L. Berkvens, D.M. Geysen and J.R. Brandt. 2001. Transmission of *Theileria parva* in the traditional farming sector in the Southern province of Zambia during 1997-98. *Tropical Animal Health and Production*, 33, 117-125.
- Nicholas, K.B. and H.B. Nicholas jnr. 1997. GeneDoc: a tool for editing and annotating multiple sequence alignments. Distributed by author.
- Norval, R.A.I., J.B. Walker and J. Colborne. 1982. The ecology of *Rhipicephalus zambeziensis* and *Rhipicephalus appendiculatus* (Acarina, Ixodidae) with



- particular reference to Zimbabwe. Onderstepoort Journal of Veterinary Research, 49, 181-190.
- Norval, R.A.I., B.D. Perry and A.S. Young. 1992. Introduction (pp xi-xii). *In: The epidemiology of theileriosis in Africa*, pp 481. Academic Press, London.
- Posada, D. and K.A. Crandall. 1998. Modeltest: testing the model of DNA substitution. *Bioinformatics*, 14, 817-818.
- Speybroeck, N., M. Madder, P. Van Den Bossche, J. Mtambo, N. Berkvens, G. Chaka, M. Mulumba, J. Brandt, L. Tirry and D. Berkvens. 2002. Distribution and phenology of ixodid ticks in southern Zambia. *Medical and Veterinary Entomology*, 16, 430-441.
- Speybroeck, N., M. Madder, H.H. Thulke, J. Mtambo, L. Tirry, G. Chaka, T. Marcotty and D. Berkvens. 2004. Variation in body size in the tick complex *Rhipicephalus appendiculatus/Rhipicephalus zambeziensis*. *Journal of Vector Ecology*, 29, 347-354.
- Swofford, D.L. 2003. PAUP\* Phylogenetic Analysis using Parsimony(\*and other methods). Sinauer Associates, Sunderland, Massachusetts.
- Thompson, J.D., T.J. Gibson, F. Plewniak, F. Jeanmougin, D.G. Higgins. 1997. The ClustalX windows interface: flexible strategies for multiple sequence alignment aided by quality analysis tools. *Nucleic Acids Research*, 25:4876-4882.
- Walker, J.B., R.A.I. Norval and M.D. Corwin. 1981. *Rhipicephalus zambeziensis* Sp. Nov., a new tick from eastern and southern Africa, together with a redescription of *Rhipicephalus appendiculatus* Neumann, 1901 (Acarina, Ixodidae). *Onderstepoort Journal of Veterinary Research*, 48, 87-104.
- Zivkovic, D., R.G. Pegram, F. Jongejan and E.T. Mwase. 1986. The biology of *Rhipicephalus appendiculatus* and *R. zambeziensis* and production of a fertile hybrid under laboratory conditions. *Experimental and Applied Acarology*, 2, 285-298.



## **Chapter 8 - USING PHYLOGENETIC METHODS TO ASSESS RELATIONSHIPS BETWEEN THE DIFFERENT ECOLOGICAL STOCKS OF *R. APPENDICULATUS* AND *R. ZAMBEZIENSIS* FROM EASTERN AND SOUTHERN ZAMBIA**

### **Based on the Manuscript:**

Mtambo, J., M. Madder, W. Van Bortel, D. Berkvens and T. Backeljau. 2007. *Rhipicephalus appendiculatus* and *R. zambeziensis* (Acari: Ixodidae) from Zambia: a molecular reassessment of their species status and identification. *Experimental and Applied Acarology*, 41, 115-128.

## 8.1 Introduction

*Rhipicephalus appendiculatus* Neumann, 1901 and *R. zambeziensis* Walker, Norval & Corwin, 1981 are two closely related species that are the main vectors of *Theileria parva*, the causative agent of East Coast fever (ECF), a cattle disease in Eastern, Central and Southern Africa (Norval *et al.*, 1992). The most reliable morphological features by which adult specimens can be differentiated are the degree of punctation of the male conscutum and the female scutum, as well the shape of the female genital aperture. Both male and female adults of *R. zambeziensis* are more densely punctate than their *R. appendiculatus* counterparts. Female adults of *R. zambeziensis* have a genital aperture with posterior broad U-shaped lips compared to broad V-shaped lips in *R. appendiculatus* (Walker *et al.*, 2000). Immature stages of the two species differ in the proportions of their basis capituli. Based on these morphological differences and on the failure to cross-breed in captivity, Walker *et al.* (1981) considered *R. appendiculatus* and *R. zambeziensis* as two biological species. However, in areas where the two species co-occur their specific differences may be less pronounced. This appears to be the case in Zambia, where the two species co-occur over a large area (Zivkovic *et al.*, 1986).

In Zambia the biology and ecology of the two species are well documented (Pegram and Banda, 1990; Berkvens *et al.*, 1995; Berkvens *et al.*, 1998; Madder *et al.*, 1999; Chaka *et al.*, 1999; Madder *et al.*, 2002; Speybroeck *et al.*, 2002; Madder *et al.*, 2005). In the Southern province of Zambia *R. appendiculatus* and *R. zambeziensis* co-occur even on the same individual host (Speybroeck *et al.*, 2002), while in the Eastern province a high proportion of specimens morphologically intermediate between *R. zambeziensis* and *R. appendiculatus* have been reported (Berkvens *et al.*, 1998). This leads to difficulties in morphological identification which are likely to result in inaccuracies in the reported proportions and distribution of both tick species. Furthermore the existence of specimens with intermediate morphology brings into question the specific status of both taxa (Speybroeck *et al.*, 2002; Madder *et al.*, 2005) in this area.

Therefore this work had two aims: (1) to reassess the species status of both taxa. To this end, we surveyed DNA sequence variation in the complete nuclear second internal transcribed spacer (ITS2) of ribosomal DNA (rDNA) and a fragment of the

mitochondrial 12S rDNA in order to assess whether or not both nominal taxa represent well-defined taxa and; (2) to develop a PCR-RFLP assay for identification of both taxa.

## 8.2 Materials and Methods

### 8.2.1 Study area

The Southern province of Zambia is situated between latitudes (15°14-17°42S) and longitude (25°01- 28°40'E) while the Eastern province lies between latitudes (10°18-15°06S) and longitudes (29°56-33°42E).

### 8.2.2 Ticks

The reference material of *R. appendiculatus* and *R. zambeziensis* consisted of dried specimens from a colony in Onderstepoort Veterinary Institute (OVI) in Pretoria South Africa (SA) identified by Jane Walker (OVI, Pretoria). To take care of possible inbreeding effects of laboratory stock additional reference material of *R. appendiculatus* and *R. zambeziensis* were collected from the field in Hluhluwe (S28°08', E32°09) in KwaZulu Natal midlands and Rietvlei (29°10'60S, 30°16'60E) in SA respectively. Outgroup specimens and all the specimens from Southern province had been preserved in 70% ethanol at ambient temperature since 1997. Test specimens from the Eastern province were stored in the ultra-freezer (- 80°C) since 2003 (Table 8.1).

**Table 8.1: Morphological identification of ticks used in the study, their sources and years of collection**

Group	Morphological identity	Label	No.	Source & Year collected
Reference Specimens	<i>R. zambeziensis</i>	SARZ	3	Rietvlei, South Africa, 2004
	<i>R. zambeziensis</i>	SARZ	3	Colony, South Africa, 2000
	<i>R. appendiculatus</i>	SARA	3	Hluhluwe, South Africa, 2004
	<i>R. appendiculatus</i>	SARA	3	Colony, South Africa, 2000
Outgroup Specimens	<i>R. evertsi evertsi</i>	REE	5	Kazungula, Zambia, 1997
	<i>R. turanicus</i>	RT	5	Simonga, Zambia, 1998
Test Specimens	<i>R. appendiculatus</i>	RATEST	54	Southern province, Zambia, 1997 Eastern province, Zambia, 2003
	Morphological Intermediates	ITEST	15	Southern province, Zambia, 1997
	<i>R. zambeziensis</i>	RZTEST	7	Southern province, Zambia, 1997

### 8.2.3 Morphological identification

Morphological identification was carried out by means of a stereo microscope (Zeiss Stemi 2000) using the identification keys of Walker *et al.* (2000). Specimens whose degree of (con)scutal punctation relative to other specimens from the same area of collection was intermediate (on a scale of three) were deemed intermediate. In female specimens the shape of the genital aperture intermediate between U and V were used in combination with scutal punctation to define intermediate specimens.

### 8.2.4 DNA extraction, PCR amplification and nucleotide sequencing

DNA extraction was based on the method of Boom *et al.* (1990, 1999) as described in Mtambo *et al.* (2006). Two genes were targeted; the complete ITS2 and a fragment of the mitochondrial 12S rDNA. ITS2 generally shows low intra-specific variation but high inter-specific differentiation and may be therefore useful in delimiting species. The 12S rDNA was chosen for its expected high amount of intra-specific variation (Avisé, 2000), which may be useful in resolving recent speciation events (Beati and Keirans, 2001). PCR amplification of the ITS2 was done with the forward primer 3SAF (5'-CTA-AGC-GGT-GGA-TCA-CTC-GG-3') (Barker, 1998) and reverse primer ITS2R (5'-ATA-TGC-TTA-AAT-TCA-GCG-GG-3') (Domanico *et al.*, 1997). The primers SR-J-1499 (5'-TACTATGTTACGACTTAT-3') and SR-N-14594 (5'-AAACTAGGATTAGATACCC -3') (Simon *et al.*, 1994) were used to amplify the 12S rDNA. Conditions for PCR were described in Mtambo *et al.* (2006). Nucleotide sequencing was undertaken by the VIB genetic service facility (University of Antwerp), using the ABI PRISM® BigDye™ Terminator cycle sequencing kit and a capillary DNA sequencer (Applied Biosystems 3730 DNA Analyzer).

### 8.2.5 Sequence assembly, Blasting and Multiple Alignments

Sequences were assembled in ClustalX 1.83 (Thompson *et al.*, 1997), visually inspected and manually edited in GeneDoc version 2.6.001 (Nicholas and Nicholas, 1997). Sequences of the reference specimens were subjected to a BLAST search. Multiple sequences were aligned with ClustalX 1.83 with its default settings and the alignments were visually inspected with GeneDoc. The sequences were truncated to exclude unclear initial and terminal parts and to obtain uniform lengths for all sequences. Alignment files are available by anonymous FTP from <ftp.ebi.ac.uk> in directory pub/databases/embl/align under the accession numbers **ALIGN\_001058** (ITS2), **ALIGN\_001059** (12S rDNA) and **ALIGN\_001060**

(ITS2/12S rDNA). Basic DNA statistics were obtained from GeneDoc and/ or were manually calculated.

### **8.2.6 Phylogenetic analysis**

Phylogenetic analyses were performed on the ITS2 and 12S rDNA sequence data separately. The evolutionary models that best suited the 12S rDNA and ITS2 sequence data were selected with Modeltest (Posada and Crandall 1998) based on the Akaike Information Criterion. The parameters of the model were used to construct a 12S rDNA sequence data distance tree in PAUP\* version 4.0b10 (Swofford, 2003) using a Neighbour-Joining (NJ) analysis with F84 as the distance measure. The stability of the NJ tree was assessed via bootstrapping over 1000 replicates. The evolutionary model selected was then used in a Maximum Likelihood (ML) analysis using PAUP\* version 4.0b10 (Swofford, 2003). The stability of the ML tree was similarly assessed by bootstrapping over 1000 replicates. Finally the same parameters of the model selected were used in the MrBayes package (Ronquist and Huelsenbeck, 2003) to obtain a Bayesian tree. MrBayes runs two simultaneous, completely independent analyses. The starting tree for each run was random. We allowed for 1 cold chain and 3 heated chains (default settings). Stationarity was achieved after 600,000 cycles.

The analysis of the ITS2 was performed as in the 12S rDNA data. Stabilities of the NJ and ML trees so obtained were assessed via 1000 bootstrap replicates. Later the model parameters were used in MrBayes. The trees obtained from the ITS2 and 12S rDNA were not contradictory. Therefore, the two gene segments were combined and a suitable model of evolution selected in Modeltest. Phylogenetic analysis of the concatenated 12S rDNA and ITS2 data proceeded as in the individual fragments. In all the analyses gaps were treated as missing data.

### **8.2.7 Development of diagnostic PCR-RFLP markers**

The program Restrict from wEMBOSS (<http://oryx.ulb.ac.be>) which uses the REBASE database of restriction enzymes to predict cutting sites in a DNA sequence was used to search for a restriction endonuclease that would yield unique, species specific restriction digestion profiles for ITS2 and/or 12S rDNA in *R. appendiculatus* and *R. zambeziensis*. The following constraints were imposed on the program: minimum two and maximum 10 cuts per enzyme; minimum recognition sites four bp

long; blunt and sticky ends allowed; DNA is linear; and ambiguities not allowed. The restriction endonuclease *BauI* (*Bacillus aquaemaris* RFL1) was found to theoretically provide unique digestion profiles for ITS2 in the two species. This was then tested practically.

### 8.2.8 DNA template for PCR-RFLP

DNA from specimens whose identities were confirmed by phylogenetic sequence analysis was amplified by PCR. Restriction digestion was in a 25 $\mu$ L volume containing 17  $\mu$ L Mqw, 2.5  $\mu$ L 10X buffer (Tango™), 0.5  $\mu$ L Enzyme (0.1U; *BauI*), and 5  $\mu$ L amplicon. The mixture was incubated at 37°C for 150min. Fragment profiles were resolved by electrophoresis through 2% (w/v) agarose gel at 100 volts for 30 min and visualized after staining for 30min in ethidium bromide. All the seven *R. appendiculatus* and five *R. zambeziensis* ITS2 sequence types (Table 8.3) were digested for the PCR-RFLP. The digestion was repeated to ensure repeatability of the profiles obtained. In addition to the DNA from ticks already used in the phylogenetic analyses, DNA template of *R. appendiculatus* specimens from Kenya (Muguga), Rwanda (Kibungo) and Grand Comore was digested. This was to ensure that eventual specific PCR-RFLP markers had a wide geographic applicability. The Muguga specimens were third generation adults of a colony maintained at the Institute of Tropical Medicine, Antwerp (ITMA). Ticks from Rwanda were collected from cattle in 2004, killed in ethanol and later stored in the refrigerator. Only two Grand Comoro specimens were available for digestion. They were killed and maintained in ethanol, after collection from cattle in 2004. After the consistency of the digestion profiles was established 18 representative samples were digested (Fig.8.2).

## 8.3 Results

A total of 76 test specimens from the Southern and Eastern provinces in Zambia were examined, 54 of which were morphologically identified as *R. appendiculatus* (39 from the Southern province, 15 from the Eastern province), seven as *R. zambeziensis* (Southern province), and 15 as morphological intermediates (Southern province).

PCR amplifications of both the test and reference material yielded successful amplicons in 77 specimens for ITS2 (65 test and 12 reference specimens) and in 88 specimens for 12S rDNA (76 test and 12 reference specimens). A BLAST search involving the sequences of the 12 reference specimens, confirmed their morphological



identifications. The *R. zambeziensis* reference sequences had their best match with an *R. zambeziensis* sequence from Nuanetsi, Zimbabwe (ITS2 sequence accession No. **RZ U97709**; 12S rDNA sequence accession No. **AF031867**). The best match for the *R. appendiculatus* reference sequences was an *R. appendiculatus* sequence from Eastern province, Zambia (ITS2 sequence accession No. **RA U97706**; 12S rDNA sequence accession No. **AF031859**).

The 12S rDNA alignment comprised 372 bp, 24 of which were polymorphic and 21 were parsimony informative. Thirteen bp were species specific. One of the 15 intermediate specimens had a 12S rDNA haplotype that differed from the rest (Table 8.2). The Southern province *R. appendiculatus* haplotype was identical to the reference *R. appendiculatus* sequence. There were five haplotypes of *R. appendiculatus* in the Eastern province, one of which was identical to the single Southern province haplotype and was found in specimens from the Nyimba district of the Eastern province. The other four haplotypes were unique to the Eastern province.

The aligned ITS2 sequences comprised 1,116 bp, 34 of which were polymorphic, 29 were parsimony informative and 21 were species specific. Two of the 15 intermediate specimens each showed a different ITS2 sequence. There were two ITS2 sequences of *R. appendiculatus* in Eastern province. One was identical to the most common Southern province sequence and was from Nyimba district of the Eastern province. The second was unique to the Eastern province and was from the Petauke and Chipata (Table 8.3).

A summary of the sequence divergences for the two genes is given in Table 8.4. The South African *R. zambeziensis* reference specimens SARZ had identical ITS2 and 12S rDNA sequences respectively. The *R. zambeziensis* test specimen from Southern Province RZTEST showed more divergence (mean 0.0032) in 12S rDNA sequences than in ITS2 (mean=0.0008). The divergence in the ITS2 between SARZ and RZTEST was lower

**Table 8.2: Polymorphisms in the 12S rDNA of *R. appendiculatus* and *R. zambeziensis* test and reference specimens**

Sample ID.	Sequence No.	Specimens	VARIABLE BASE POSITIONS																							
			87	88	100	105	107	111	133	166	175	178	179	180	181	184	240	245	260	317	329	334	335	345	354	357
SARA	Sequence 1	6	A	T	T	T	T	A	T	A	-	T	G	T	T	T	G	A	A	T	G	T	A	T	T	C
RATEST SP	Sequence 1	3	-	-	-	-	-	-	-	-	-	-	-	-	-	-	-	-	-	-	-	-	-	-	-	-
RATEST EP	Sequence 1	3	-	-	-	-	-	-	-	-	-	-	-	-	-	-	-	-	-	-	-	-	-	-	-	-
RATEST EP	Sequence 2	3	-	C	C	-	C	-	A	-	-	-	-	-	-	A	-	-	-	A	-	-	-	-	-	-
RATEST EP	Sequence 3	4	-	-	T	-	-	-	-	-	-	-	-	-	-	-	-	-	-	G	-	-	-	-	-	-
RATEST EP	Sequence 4	2	-	-	C	-	-	-	T	-	-	-	-	-	-	-	-	-	-	A	-	-	-	-	-	-
RATEST EP	Sequence 5	1	-	-	T	-	-	-	T	-	-	-	-	-	C	-	-	-	-	G	-	-	-	-	-	-
SARZ	Sequence 6	6	T	A	T	T	C	A	T	T	A	A	A	A	T	T	G	A	T	C	A	C	T	A	C	C
RZTEST	Sequence 7	10	-	T	-	-	-	-	-	-	-	-	-	-	-	-	-	-	-	-	-	-	-	-	-	-
RZTEST	Sequence 8	4	-	-	-	C	-	-	-	-	-	-	-	-	-	-	-	-	-	-	-	-	-	-	-	-
RZTEST	Sequence 9	3	-	-	-	T	-	T	-	-	-	-	-	-	-	-	-	-	-	-	-	-	-	-	-	-
ITEST	Sequence 9	1	-	-	-	T	-	T	-	-	-	-	-	-	-	-	-	-	-	-	-	-	-	-	-	-
RZTEST	Sequence 10	1	-	-	-	-	-	A	-	-	-	-	-	-	-	-	-	-	-	-	-	-	-	-	-	T
ITEST	Sequence 11	1	-	-	-	-	-	-	-	-	-	-	-	-	-	-	G	-	-	-	-	-	-	-	-	C

**Key**

SARA = *R. appendiculatus* reference specimens; SARZ = *R. zambeziensis* reference specimens; RATEST = *R. appendiculatus* from Southern and Eastern provinces of Zambia; ITEST = Specimen of intermediate morphology from Southern province; RZTEST = *R. zambeziensis* from Southern province

**Table 8.3: Polymorphisms in the ITS2 rDNA of *R. appendiculatus* and *R. zambeziensis* test and reference specimens**

Sample ID	Sequence no.	Specimens	VARIABLE BASE POSITIONS																																		
			67	104	130	134	147	148	169	187	250	266	298	317	365	390	397	6	424	446	491	588	629	646	649	668	729	790	801	804	834	840	879	888	915	1113	
SARA	Sequence 1	5	G	C	A	A	G	A	G	G	A	A	C	A	A	G	G	G	T	C	T	A	A	T	C	C	A	C	T	G	A	A	T	A	T	T	
RATEST SP	Sequence 1	18	-	-	-	-	-	-	-	-	-	-	-	-	-	-	-	-	-	-	-	-	-	-	-	-	-	-	-	-	-	-	-	-	-	-	-
RATEST EP	Sequence 1	3	-	-	-	-	-	-	-	-	-	-	-	-	-	-	-	-	-	-	-	-	-	-	-	-	-	-	-	-	-	-	-	-	-	-	
ITEST SP	Sequence 2	2	-	-	-	-	-	-	-	-	-	-	-	-	-	-	-	-	-	-	C	-	-	-	-	-	-	-	-	-	-	-	-	-	-	-	
RATEST SP	Sequence 3	4	-	-	-	-	-	-	-	-	-	-	-	-	-	-	-	-	-	-	T	-	-	-	-	-	-	-	-	-	-	-	-	-	-	-	
RATEST EP	Sequence 4	9	-	-	-	-	-	-	-	-	-	-	-	-	-	-	-	-	-	-	-	-	-	-	-	-	-	-	G	-	-	-	-	-	-	-	
ITEST SP	Sequence 5	1	-	-	-	-	A	-	-	-	-	A	-	-	-	-	-	-	-	T	-	-	-	-	-	-	-	-	-	-	-	-	-	-	-	-	
RATEST SP	Sequence 6	4	-	-	-	-	G	-	-	-	-	C	-	-	C	-	-	-	C	-	-	-	-	-	-	-	-	-	T	-	-	-	-	-	-	-	
SARA	Sequence 7	1	-	-	-	-	-	-	-	-	-	-	-	-	-	-	-	-	-	-	-	-	G	-	-	-	-	-	-	-	-	-	-	-	-	-	
RATEST	Sequence 7	2	-	-	-	-	-	-	-	-	-	-	-	-	-	-	-	-	-	-	-	-	G	-	-	-	-	-	-	-	-	-	-	-	-	-	
SARZ	Sequence 8	6	A	T	G	T	A	G	-	A	-	G	-	G	G	-	-	A	C	A	-	G	A	C	T	G	T	T	-	C	-	G	C	T	C	-	
RZTEST	Sequence 8	6	-	-	-	-	-	-	-	-	-	-	-	-	-	-	-	-	-	-	-	-	-	-	-	-	-	-	-	-	-	-	-	-	-	-	-
RZTEST	Sequence 9	1	-	-	-	-	-	A	-	-	-	-	-	-	-	-	-	-	-	-	-	-	-	-	-	-	-	-	-	-	-	-	-	-	-	-	
RZTEST	Sequence 10	1	-	-	-	-	-	G	-	G	-	-	-	-	-	-	-	-	-	-	-	-	-	-	-	-	-	-	-	-	-	-	-	-	-	-	-
RZTEST	Sequence 11	3	-	-	-	-	-	-	-	A	-	-	-	-	-	-	C	-	-	-	-	-	-	-	-	-	-	-	-	-	-	-	-	-	-	-	-
RZTEST	Sequence 12	1	-	-	-	-	-	-	-	-	-	-	-	-	-	-	-	-	-	-	-	-	-	-	-	-	-	-	-	-	-	-	-	-	-	-	C

**Key**

SARA = *R. appendiculatus* reference specimens; SARZ = *R. zambeziensis* reference specimens; RATEST = *R. appendiculatus* test specimens from Southern and Eastern provinces of Zambia; ITEST = Test specimens of intermediate morphology from Southern province; RZTEST = *R. zambeziensis* test specimens from Southern province

0.0005) than within the RZTEST (0.0008) test specimens. However, in the 12S rDNA the divergence within the RZTEST was lower (0.0032) than that between SARZ and RZTEST (0.0042). The ITS2 mean sequence divergence between SARZ and RT was larger (0.0837) than that between the SARZ and REE (0.0782). A similar divergence pattern was observed between the two outgroup species and the SARZ in the 12S rDNA sequences.

The mean ITS2 sequence divergence within the *R. appendiculatus* reference group from South Africa (SARA) was 0.0016. There was no variation of the 12S rDNA in the SARA group. Both ITS2 and 12S rDNA sequence divergences between SARA and the two outgroups were smaller than the divergences between SARZ and the outgroup species. The pattern and extent of diversion was similar for the corresponding test specimen sequences. The intermediate test specimens from Southern Province ITEST had the highest within group mean divergence in both the ITS2 and 12S rDNA viz. 0.0152 and 0.0124 respectively.

**Table 8.4: Sequence divergence within and between *R. appendiculatus*, *R. zambeziensis*, intermediate, reference, test and outgroup material**

Tick Group	Gene	No. of Specimens		Morphologically Identified Group					Outgroups	
				SARZ	RZTEST	SARA	RATEST	ITEST	REE	RT
SARZ	ITS2	6	range	0.0000	0.0000-0.0018	0.0219-0.0239	0.0210-0.0248	0.0000-0.0229	0.0764-0.0792	0.0834-0.0845
			mean	<b>0.0000</b>	<b>0.0005</b>	<b>0.0231</b>	<b>0.0236</b>	<b>0.0117</b>	<b>0.0782</b>	<b>0.0837</b>
RZTEST	ITS2	7	range		0.0000-0.0008	0.0219-0.0258	0.0210-0.0267	0.0000-0.0248	0.0764-0.0814	0.0833-0.0866
			mean		<b>0.0008</b>	<b>0.0236</b>	<b>0.0240</b>	<b>0.0122</b>	<b>0.0788</b>	<b>0.0842</b>
SARA	ITS2	6	range			0.0000-0.0036	0.0000-0.0054	0.0009-0.0258	0.0709-0.0752	0.0791-0.0824
			mean			<b>0.0016</b>	<b>0.0015</b>	<b>0.0133</b>	<b>0.0735</b>	<b>0.0808</b>
RATEST	ITS2	54	range				0.0000-0.0054	0.0000-0.0267	0.0701-0.0762	0.07801-0.0825
			mean				<b>0.0014</b>	<b>0.0133</b>	<b>0.0740</b>	<b>0.0809</b>
ITEST	ITS2	9	Range					0.0000-0.0396	0.0712-0.0813	0.0791-0.0866
			mean					<b>0.0152</b>	<b>0.0764</b>	<b>0.0823</b>
SARZ	12s rDNA	6	range	0.0000	0.0027-0.0054	0.0396	0.0368-0.0397	0.0027-0.0396	0.1265	0.0957-0.0992
			mean	<b>0.0000</b>	<b>0.0046</b>	<b>0.0396</b>	<b>0.0396</b>	<b>0.0129</b>	<b>0.1265</b>	<b>0.0980</b>
RZTEST	12s rDNA	7	range		0.0000-0.0054	0.0366-0.0396	0.0366-0.0426	0.0000-0.0396	0.1260-0.1265	0.0922-0.0993
			mean		<b>0.0032</b>	<b>0.0387</b>	<b>0.0397</b>	<b>0.0121</b>	<b>0.1264</b>	<b>0.0972</b>
SARA	12s rDNA	6	range			0.0000	0.0000-0.0137	0.0000-0.0396	0.1126	0.0818-0.0852
			mean			<b>0.0000</b>	<b>0.0025</b>	<b>0.0286</b>	<b>0.1126</b>	<b>0.0841</b>
RATEST	12s rDNA	54	range				0.0000-0.0137	0.0000-0.0426	0.1126-0.1197	0.0818-0.0885
			mean				<b>0.0025</b>	<b>0.0297</b>	<b>0.1137</b>	<b>0.0848</b>
ITEST	12s rDNA	15	range					0.0000-0.0248	0.1126-0.1265	0.0818-0.0992
			mean					<b>0.0124</b>	<b>0.1215</b>	<b>0.0932</b>

**Key**

SARA: = morphologically identified *R. appendiculatus* reference specimens from South Africa; SARZ: = morphologically identified *R. zambeziensis* reference specimens from South Africa; RATEST: = morphologically identified *R. appendiculatus* from Southern and Eastern provinces; ITEST: = morphologically identified intermediate specimen from Southern province; REE: = *R. evertsi evertsi*; RT: = *R. turanicus*

Modeltest gave GTR +I as the evolutionary model of choice for the concatenated data. The parameters of the model were: base frequencies= freqA=0.2208, freqC=0.2561, freqG=0.2911, freqT=0.2319); Rmat= (1.2451, 4.5017, 5.8684, 0.9856, 6.4344); Rates=equal; and Pinvar=0.6956. The Ts/Tv ratio was 1.7. An ML tree of the concatenated ITS2 and 12S rDNA sequence data is presented (fig.8.1). The tree was well resolved with *R. appendiculatus* and *R. zambeziensis* each as well-supported monophyletic groups with high bootstrap support (BS) values (see fig.8.1 (A) for the BS values). The *R. appendiculatus* group was further subdivided in two groups: (1) an all Eastern province and well supported monophyletic group without ticks from Nyimba district and, (2) a polytomy of Southern province specimens, South African reference specimens and ticks from Nyimba district in the Eastern province.

The best fit model for the 12S rDNA sequences as determined by Modeltest was K81uf + G (Kimura 1981 with unequal base frequencies and a gamma shape rate distribution) which is equivalent to the GTR +G (General time reversible model with gamma distribution of sites) as. The parameters of this model were: Rate matrix (Rmat) = (1.0000, 16260659.0000, 9272497.0000, 9272497.0000, 16260659.0000); base frequencies; freqA=0.3675, freqC= 0.1208, freqG=0.0990, freqT= 0.4127; proportion of invariable sites (Pinvar) = 0; transition/transversion ratio (Ts/Tv) was 1.4 and; rates= gamma with a shape parameter ( $\alpha$ ) = 0.0750. The NJ 12S rDNA tree (not shown) was well resolved with *R. appendiculatus* and *R. zambeziensis* each as well-supported monophyletic groups with bootstrap support (BS) 93% and 100% respectively. The *R. appendiculatus* group was further subdivided in two monophyletic groups (1) with BS 78% and (2) with BS 95% as in the concatenated ML tree. The Bayesian tree for the 12S rDNA was not so well-resolved but had 100% clade credibility (CC) for the *R. zambeziensis* group while the *R. appendiculatus* group was a polytomy with 98% CC for group (1) and 96% CC for group (2). The ML tree had *R. zambeziensis* group (BS 61%) and *R. appendiculatus* (BS 99%). The two groups within *R. appendiculatus* were not supported i.e. BS 50% for group (1) and 42% for group (2).

The evolutionary model that best suited ITS2 data was the GTR + I (General time reversible model with a proportion of invariable sites). The parameters of the model were: Base frequencies; FreqA=0.1752, freqC= 0.2992, freqG= 0.3514 and freqT=

0.1742; Rmat= (1.0246, 2.4196, 1.6462, 0.5664, and 4.2570); Rates=equal; and Pinvar=0.6161 and Ts/Tv=1.66. The ITS2 tree's features (not shown) were very similar to the concatenated tree with higher bootstrap and clade credibility values than the 12S tree for all the two species groups and the two within *R.appendiculatus* groups.

Out of the 39 test specimens from the Southern province morphologically identified as *R. appendiculatus* i.e. RATEST, six grouped with *R. zambeziensis* on both the ITS2 and 12S rDNA phylograms. Based on the sequence data two of the 15 intermediate specimens ITEST were assigned to *R. appendiculatus* and 13 to *R. zambeziensis*. The seven specimens morphologically identified as *R. zambeziensis* i.e. RZTEST were confirmed by the DNA data.

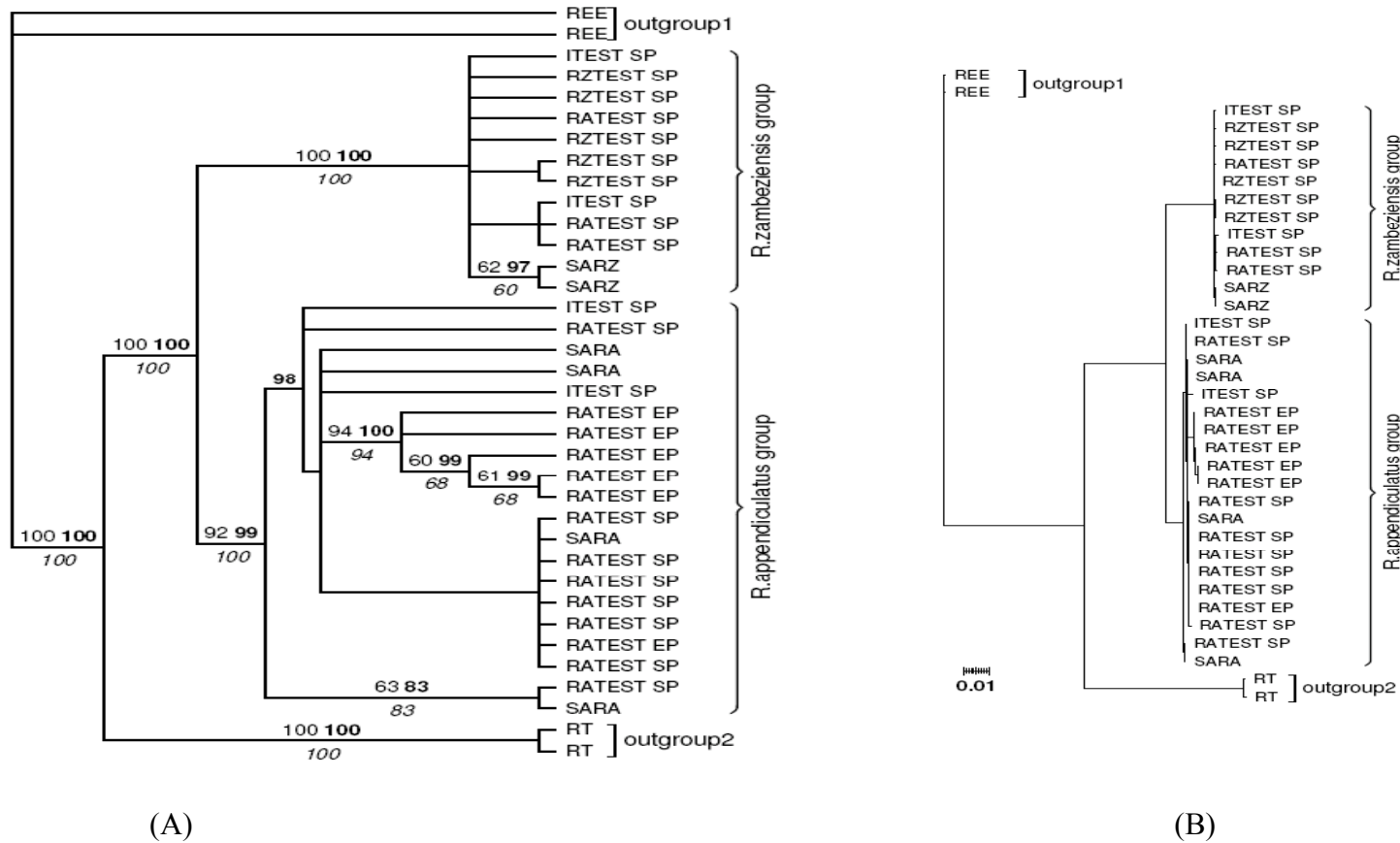
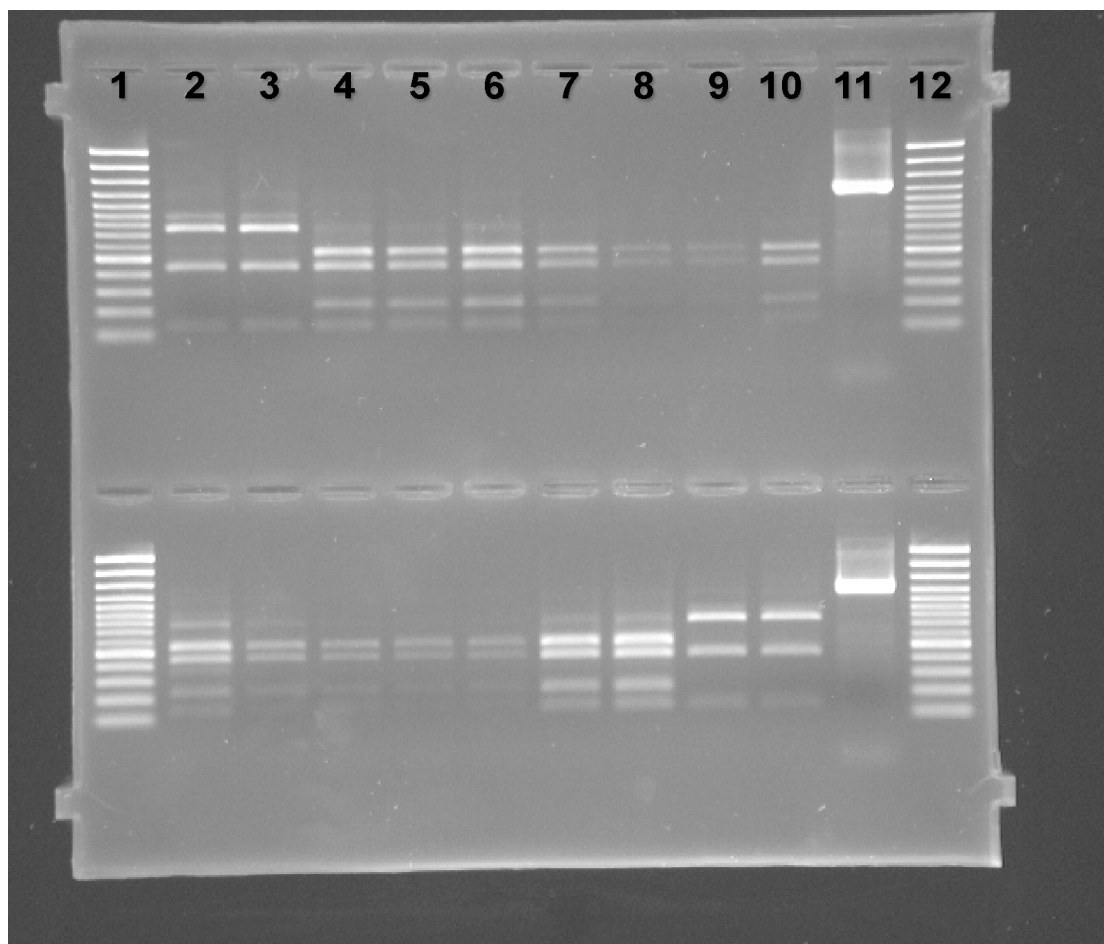

Figure 8.1: (A): Maximum Likelihood (ML) tree (cladogram) of combined ITS2 and 12S rDNA with Bootstrap support and clade credibility values Top left=ML (normal font); top right=Bayesian inference (Bold font); Bottom =NJ (Italics). Fig. 8.1 (B): ML tree (phylogram) of the combined ITS2 and 12S rDNA sequences



The restriction profile is presented in fig. 8.2. The reference and test specimens of *R. zambeziensis* had the same restriction profile. This profile was different from that of reference *R. appendiculatus* (SARA). The SARA profile was identical for all the specimens that were grouped with the SARA on the phylogenetic tree. The intermediates had profiles consistent with their grouping on the phylogenetic tree i.e. those that grouped with *R. appendiculatus* had an *R. appendiculatus* profile and those that grouped with *R. zambeziensis* had an *R. zambeziensis* profile. The restriction patterns for the two species were consistent for all geographic areas including areas outside Zambia i.e. Rwanda and Kenya.



**Figure 8.2: *BauI* Restriction digestion profile for variable sequences of the ITS2 PCR amplicon (1200bp) for *R. zambeziensis* and *R. appendiculatus*.**

Lanes 1, 12, 13 & 24 = 100+ ladder; Lane 2, Sequence 8= *R. zambeziensis* SARZ (Colony); Lane 3, Sequence 8= *R. zambeziensis* SARZ (Rietvlei); Lane 4, Sequence

1= *R. appendiculatus* SARA (Hluhluwe); Lane 5, Sequence 7 = *R. appendiculatus* SARA (Colony); Lanes 6, Sequence 3= *R. appendiculatus* RATEST; Lane 7, Sequence 4= *R. appendiculatus* RATEST EP; Lane 8, Sequence 6= *R. appendiculatus* RATEST SP; Lanes 9, Sequence 2= ITEST; Lane 10, Sequence 5= ITEST; Lanes 11 and 23, digestion control=1200bp undigested ITS2 amplicon; Lanes 14, 15 and 16, *R. appendiculatus*=Rwanda; Lanes 17 and 18, *R. appendiculatus*=Grand Comoro; Lanes 19 and 20, *R. appendiculatus*=Muguga, Kenya; Lane 21, Sequence 10= *R. zambeziensis* RZTEST; Lane 22, Sequence 11 =*R. zambeziensis* RZTEST.

## 8.4 Discussion

Vector identification is traditionally achieved by morphological criteria. Unfortunately, morphological criteria have little or no discriminatory power in the case of closely related species, such as *R. appendiculatus* and *R. zambeziensis* (Walker *et al.*, 2000). The present DNA sequence data, however, show convincingly that the two nominal taxa should be regarded as two separate species, at least in the phylogenetic sense. The consistently high bootstrap values for the two clades in the phylogenetic trees support the distinctiveness of the two groups. These results are in line with those of Barker (1998) and Murrell *et al.* (2001). The different glucose phosphate isomerase (GPI) isoenzyme zymograms for the two species (Wouters *et al.*, 1987) also support these results. Moreover, the two taxa further differ in their (1) behaviour, e.g. *R. appendiculatus* readily feeds on rabbits, while *R. zambeziensis* does not, (2) survival times under different temperature and humidity conditions, with *R. zambeziensis* surviving better under more extreme conditions than *R. appendiculatus* (Madder *et al.*, 2005), (3) life history characteristics with (a) *R. zambeziensis* showing generally longer development periods and higher egg production than *R. appendiculatus* (Zivkovic *et al.*, 1986), and (b) *R. appendiculatus* sometimes passing through a diapause, while *R. zambeziensis* never passes through a diapause (Madder *et al.*, 1999; Madder *et al.*, 2002) and, (4) the vectorial competence of their nymphs for *T. parva* (Mulumba, 1999) with *R. zambeziensis* being more competent than *R. appendiculatus*.

Since cross-breeding in the wild is not incompatible with phylogenetic species (Mayden, 1997), it is possible that *R. appendiculatus* and *R. zambeziensis* may do so. Cross-breeding of the two taxa in captivity has at least been demonstrated by

Zivkovic *et al.* (1986). Cross-breeding in captivity, however, does not necessarily confirm its occurrence in the wild. Nevertheless, evidence of the possible existence of natural hybrids was observed in a single field specimen with a GPI zymogram similar to the ones obtained from captive F<sub>1</sub> hybrids (Berkvens, 2002). Zivkovic *et al.* (1986) further demonstrated *T. parva* transmission by the F<sub>1</sub> progeny of the cross *R. zambeziensis* (female) X *R. appendiculatus* (male). However, the effect that such eventual natural hybrids may have on the epidemiology of ECF is still unknown. Therefore further studies on the possibility of inter-specific hybridisation in the field are needed.

Specimens of intermediate morphology have been reported in both taxa when exposed to suboptimal conditions during their life cycle (Nuttall, 1914; Walker *et al.*, 2000). They have been reported too in the F<sub>1</sub> progeny of the cross *R. appendiculatus* (female) X *R. zambeziensis* (male) (Zivkovic *et al.*, 1986). It is not clear which of these two possible origins apply to the intermediate specimens we observed.

The robust molecular evidence that *R. appendiculatus* and *R. zambeziensis* can be grouped according to their nominal taxonomic status is important for the control of ECF. Decision makers in the control of ECF in Zambia need therefore to correctly account for the two different components of the species complex. This is important because their roles in the epidemiology of ECF are different (Mulumba, 1999). Ignoring a component of the species complex may impact negatively on disease control decisions (Speybroeck *et al.*, 2002).

The two groups within *R. appendiculatus* could be broadly divided into the two provinces (Eastern and Southern) with the exclusion of samples from Nyimba. The Eastern province group was consistently supported as a monophyletic unit, while the Southern province group was an unresolved polytomy. A further study to explore and explain this phenomenon is envisaged.

Finally, the PCR-RFLP diagnostic assay developed proved to be applicable over a wide range of the distribution of the two tick taxa. It will be useful for confirming previous and current morphological identifications of *R. appendiculatus* and *R. zambeziensis*. It should likewise be useful in the determination of the presence or absence of *R. zambeziensis* in Eastern province where the overlap in both morphology and biology of the two taxa raises questions as to whether or not this taxon is present.

This PCR-RFLP assay is more practical than GPI electrophoresis (Wouters *et al.*, 1987) because the latter is only applicable to cryopreserved specimens. Specimens for use in PCR-RFLP, on the other hand, can be stored in a number of ways (Mtambo *et al.*, 2006). The PCR-RFLP assay has identical profiles for the two sub groups within the *R. appendiculatus* group and its use is therefore limited to confirmation of *R. appendiculatus* and *R. zambeziensis*. Accurate information about the distribution and dynamics of the two species in the field will facilitate effective planning for ECF control.

## 8.5 References

- Avise, J.C. 2000. Phylogeography: the history and formation of species. Harvard University Press, Cambridge and London.
- Barker, S.C. 1998. Distinguishing species and populations of Rhipicephaline ticks with ITS2 ribosomal RNA. *Journal of Parasitology*, 84, 887-892.
- Beati, L. and J.E. Keirans. 2001. Analysis of the systematic relationships among ticks of the genera *Rhipicephalus* and *Boophilus* (Acari: Ixodidae) based on the mitochondrial 12S ribosomal DNA gene sequences and morphological characters. *Journal of Parasitology*, 87, 32-48.
- Berkvens, D.L., R.G. Pegram and J.R.A. Brandt. 1995. A study of the diapausing behaviour of *Rhipicephalus appendiculatus* and *R. zambeziensis* under quasi-natural conditions in Zambia. *Medical and Veterinary Entomology*, 9, 307-315.
- Berkvens, D.L., D.M. Geysen, G. Chaka, M. Madder and J. R.A. Brandt. 1998. A survey of the ixodid ticks parasitizing cattle in the Eastern province of Zambia. *Medical and Veterinary Entomology*, 12, 234-240.
- Berkvens, N. 2002. Differentiatie van teken van het *Rhipicephalus appendiculatus/R. zambeziensis* complex uit Zambia. Scriptie voorgedragen tot het behalen van de graad van Bio-ingenieur in de Landbouw. Ghent University.
- Boom, R., C.J.A. Sol, M.M.M. Salimans, C.L. Jansen, P.M.E. Wertheim-van Dillen and J. Van Der Noordaa. 1990. Rapid and simple method of purification of nucleic acids. *Journal of Clinical Microbiology*, 28, 495-503.
- Boom, R., C. Sol, M. Beld, J. Weel, J., Goudsmit, P.M.E. Wertheim-van Dillen. 1999. Improved silica-guanidiniumthiocyanate DNA isolation procedure based on selective binding of bovine alpha-casein to silica particles. *Journal of Clinical Microbiology*, 37, 615-619.
- Chaka, G., M. Billiouw, D.M. Geysen and D. L. Berkvens. 1999. Spatial and temporal variation in *Rhipicephalus appendiculatus* size in eastern Zambia. *Tropical Medicine and International Health*, 4, A43-A48.
- Domanico, M.J., R.B. Phillips and T.H. Oakley. 1997. Phylogenetic analysis of Pacific salmon (genus *Oncorhynchus*) using nuclear and mitochondrial DNA sequences. *Canadian Journal of Fisheries and Aquatic Sciences*, 54, 1865-1872.
- Madder, M., N. Speybroeck, J. Brandt and D. Berkvens. 1999. Diapause induction in adults of three *Rhipicephalus appendiculatus* stocks. *Experimental and Applied Acarology*, 23, 961-968.
- Madder, M., N. Speybroeck, J. Brandt, L. Tirry, I. Hodek and D. Berkvens. 2002. Geographic variation in diapause response of adult *Rhipicephalus appendiculatus* ticks. *Experimental and Applied Acarology*, 27, 209-221.
- Madder, M., N. Speybroeck, A. Bilounga, D. Helleputte and D. Berkvens. 2005. Survival of unfed *Rhipicephalus appendiculatus* and *Rhipicephalus zambeziensis* adults. *Medical and Veterinary Entomology*, 19, 245-250.

- Mayden, R.L. 1997. A hierarchy of species concepts: the denouement in the saga of the species problem. In: Claridge, M.F., Dawah, H.A., Wilson, M.R. (Ed.), *Species: the units of biodiversity*, Chapman and Hall, London, pp. 382-425.
- Mtambo, J., W. Van Bortel, M. Madder, P. Roelants and T. Backeljau. 2006. Comparison of preservation methods of *Rhipicephalus appendiculatus* (Acari: Ixodidae) for reliable DNA amplification by PCR. *Experimental and Applied Acarology*, 38, 189-199.
- Murrell, A., N.J.H. Campbell and S.C. Barker. 2001. A total-evidence phylogeny of ticks provides insights into the evolution of life cycles and biogeography. *Molecular Phylogenetics and Evolution*, 21, 244-258.
- Mulumba, M. 1999. Epidemiology of *Theileria parva* theileriosis in the Southern province of Zambia. PhD thesis, Institute of Tropical Medicine, Antwerp, Belgium, 158pp.
- Nicholas, K.B. and H. B. Nicholas jnr. 1997. GeneDoc: a tool for editing and annotating multiple sequence alignments. Distributed by author. <http://www.psc.edu/biomed/genedoc/gddl.htm>.
- Norval, R.A.I., B.D. Perry and A.S. Young. 1992. The epidemiology of theileriosis in Africa, pp 99. Academic Press, London.
- Nuttall, G.H.F. 1913-1914. *Rhipicephalus appendiculatus*: variation in size and structure due to nutrition. *Parasitology*, 6, 195-204.
- Pegram, R.G. and D.S. Banda. 1990. Ecology and phenology of the cattle ticks in Zambia: development and survival of free-living stages. *Experimental and Applied Acarology*, 9, 291-301.
- Posada, D. and K.A. Crandall. 1998. Modeltest: testing the model of DNA substitution. *Bioinformatics*, 14, 817-818.
- Ronquist, F. and J.P. Huelsenbeck. 2003. MRBAYES: Bayesian phylogenies under mixed models. *Bioinformatics*, 19, 1572- 1574.
- Simon, C., F. Frati, A. Beckenbach, B. Crespi, H. Liu and P. Flook. 1994. Evolution, weighting and phylogenetic utility of mitochondrial gene sequences and a compilation of conserved polymerase chain reaction primers. *Annals of the Entomological Society of America*, 87, 651- 701.
- Speybroeck, N., M. Madder, P. Van Den Bossche, J. Mtambo, N. Berkvens, G. Chaka, M. Mulumba, J. Brandt, L. Tirry and D. Berkvens. 2002. Distribution and phenology of ixodid ticks in Southern Zambia. *Medical and Veterinary Entomology*, 16, 430-441.
- Swofford, D.L. 2003. PAUP\* Phylogenetic Analysis using Parsimony (\*and other methods). Sinauer Associates, Sunderland, Massachusetts.
- Thompson, J.D., T.J. Gibson, F. Plewniak, F. Jeanmougin and D.G. Higgins. 1997. The ClustalX windows interface: flexible strategies for multiple sequence alignment aided by quality analysis tools. *Nucleic Acids Research*, 25, 4876-4882.
- Walker, J.B., R.A.I. Norval and M.D. Corwin. 1981. *Rhipicephalus zambeziensis* sp. nov., a new tick from eastern and southern Africa, together with a

- redescription of *Rhipicephalus appendiculatus* Neumann, 1901 (Acarina, Ixodidae). Onderstepoort Journal of Veterinary Research, 48, 87-104.
- Walker, J.B., J.E. Keirans and I.G. Horak. 2000. The Genus *Rhipicephalus* (Acari: Ixodidae): a guide to the brown ticks of the world. Cambridge University Press, Cambridge.
- Wouters, G., J. Brandt and D. Berkvens. 1987. Species characterization of *Rhipicephalus appendiculatus* and *Rhipicephalus zambeziensis* (Ixodidae: Acarina) by enzyme-electrophoresis. Annales de la Société belge de médecine tropicale, 67, 267-270.
- Zivkovic, D., R.G. Pegram, F. Jongejan and E.T. Mwase. 1986. The biology of *Rhipicephalus appendiculatus* and *R. zambeziensis* and production of a fertile hybrid under laboratory conditions. Experimental and Applied Acarology, 2, 285-298.





**Chapter 9 - COMPARISON OF THE QUALITY OF DNA  
EXTRACTED FROM PRESERVED *RHIPICEPHALUS  
APPENDICULATUS* MATERIAL FOR PCR  
AMPLIFICATION**

**Based on the Manuscript:**

Mtambo, J., W. Van Bortel, M. Madder, P. Roelants and T. Backeljau. 2006.  
Comparison of preservation methods of *Rhipicephalus appendiculatus*  
(Acari: Ixodidae) for reliable DNA amplification by PCR. *Experimental and  
Applied Acarology*, 38, 189-199.

## 9.1 Introduction

DNA is a relatively stable molecule that may stay intact for an extremely long time under the right conditions. The time span over which DNA integrity of biological specimens is maintained is a function of the preservation conditions (Phillips and Simon, 1995)

For insects the most effective method for preserving specimens for DNA work is ultra-cold (-80°C) freezing of live specimens (Cruickshank, 2002). The second most effective method is killing and preserving insects in 100% ethanol and keeping them in a refrigerator (Cruickshank, 2002; Dillon *et al.*, 1996). Tick specimens for DNA work have been preserved in a number of ways including absolute ethanol stored at -20°C (Guglielmone *et al.*, 2003; Mangold *et al.*, 1998), ultracold freezing (Hernandez *et al.*, 1998; McLain *et al.*, 1995), TE buffer at -70°C (Murrell *et al.*, 2001; Crampton *et al.*, 1996), 70% ethanol/5% glycerol (Crosbie *et al.*, 1998) and 70% Ethanol (Crosbie *et al.*, 1998, Barker, 1998). However, no study has yet compared the quality of tick DNA isolated from samples preserved by different methods for subsequent PCR amplification.

A number of methods have been used to isolate DNA from ticks (Hubbard *et al.*, 1995; Hernandez *et al.*, 1998; Hill and Gutierrez, 2003). Different methods of DNA isolation may yield varying quality of DNA (Hill and Gutierrez, 2003).

In this study we compared the quality of DNA extraction from *R.appendiculatus* specimens preserved in five different ways. Three DNA extraction methods were applied to five sample preservation types. The quality of DNA obtained was compared by the PCR amplification success of their ribosomal second internal transcribed spacer (ITS2) and a fragment of their mitochondrial cytochrome c oxidase I (COI) genes. Finally we used the most successful of the three DNA extraction methods to explore the possibility of isolating DNA from legs of individual specimens of each of the five preservation groups.

## 9.2 Materials and Methods

### Ticks

These consisted of five groups of differently preserved adult *R. appendiculatus* from three countries namely, Rwanda, Zambia and South Africa collected at different

periods for studies other than the current. Thirty individuals were sampled from each of the five preservation types, except for material preserved in the refrigerator (4°C) of which only 28 specimens were used. The five preservation types were: (1) fresh, (2) dried, (3) 70% ethanol, (4) cryopreserved and (5) refrigerated tick specimens.

## 9.2.1 Ticks

### 9.2.1.1 Fresh ticks:

These were sixth generation specimens from a colony at the Institute of Tropical Medicine, Antwerp (ITMA). This colony was established in 2003 from adults (50 males and 50 females) of a colony maintained in Mazabuka, Zambia for ecological studies. All instars were fed on rabbits, and maintained at 20-22°C and 85%RH.

### 9.2.1.2 Dried ticks

These specimens were from a colony at Onderstepoort Veterinary Institute (Pretoria) collected from Rietvlei, in Mpumalanga, South Africa. The ticks were killed in the year 2000 by putting them in a refrigerator (4°C) and allowed to air dry. They were then put in sealed conical tubes and maintained at ambient temperature.

### 9.2.1.3 Ethanol (70%) preserved ticks

These specimens were collected from cattle in 1995 at Nega Nega village in Mazabuka district of southern Zambia (Speybroeck *et al.*, 2002). They were killed in 70% ethanol immediately upon collection from cattle and maintained in the same in sealed vacutainers at ambient temperature.

### 9.2.1.4 Cryopreserved ticks

These specimens were collected in 2002 at Nkonkola village in Mazabuka district. The specimens were killed and maintained in an ultracold refrigerator (-80°C) at Mazabuka Veterinary Research Station. They were transported to ITMA in a dry shipper (-150°C) and returned to the ultracold refrigerator upon arrival.

### 9.2.1.5 Refrigerator preserved ticks

These specimens were collected from Kibungo district in Rwanda 2004. They were killed immediately upon collection in 70% ethanol. At the laboratory in Kigali, the samples were washed in tap water and allowed to air dry to remove excess tap water. They were then put in Ziplock bags with silica gel and stored in the refrigerator (4°C).

Due to the limited numbers of these specimens, only the tick validated DNA extraction method (method 3) was applied to this group.

## 9.2.2 DNA extraction

### 9.2.2.1 Pre-treatment of samples

Specimens in 70% ethanol were washed in tap water, and rinsed in TE buffer (10mM Tris-HCl [pH 8.0], 1mM EDTA). Dried specimens were washed in alcohol first followed by tap water and re-hydrated in TE buffer for six hours. Individual specimens were blotted to remove excess TE buffer prior to cutting. Manipulation of cryopreserved specimens was done on ice.

### 9.2.2.2 Method 1: TE buffer

This method was chosen because it is very fast and simple. It has been used in the isolation of DNA from mosquito specimens (WVB unpublished). Individual specimens were cut into 6-8 pieces with a scalpel blade on a petri-dish. The pieces were put in 1.5ml microfuge tubes to which 30µl TE buffer was added. The DNA mixes were then stored at -20°C to be used as template when required.

### 9.2.2.3 Method 2: Collins *et al.* (1987)

This method has been used in isolating DNA from mosquitoes. The extraction process is completed within 3 hours. Individual specimens were cut into 6-8 pieces with a scalpel blade in a petri-dish and put in a 1.5ml microfuge tube to which 50µl heat inactivated (65°C for 30 min) extraction buffer (0.08M NaCl; 0.06M EDTA [pH 8.0], pH adjusted with NaOH; 0.10M Tris-HCl [pH 8.6]; 0.5% SDS; 0.16M sucrose) was added. The tubes were incubated in a thermoblock at 65°C for 30 min following which 7µl 8M KAc, was added to precipitate the protein SDS complex. The tubes were then placed on ice for 30 min. This was followed by cooled (4°C) centrifugation for 10 min at 12000g. The supernatant was transferred into clean tubes to which 100µl cold absolute ethanol was added. The tubes were again put on ice for 5 min after which they were centrifuged for 20 min at 16000g. The supernatant was discarded. The pellet was washed with 150µl cold (-20°C) 70% ethanol, centrifuged for 5 min and the supernatant discarded. Cold (-20°C) absolute ethanol (150µl) was added to the pellet and centrifuged for 5 min. Ethanol was then discarded gently by flipping the tube without disturbing the pellet. The pellet (often not visible to the naked eye) was

allowed to air dry, following which 25µl TE buffer was added to dissolve the pellet and the solution was stored at -20°C.

#### 9.2.2.4 Method 3: Boom *et al.* (1990, 1999)

This method is very similar to that of Hubbard *et al.* (1995) that allows for successful amplification of DNA from ticks preserved in ethanol for almost 100 years. Using a scalpel blade whole ticks were cut singly into 6-8 small pieces and transferred to 1.5ml microfuge tube to which 250µl lysis buffer (1M Tris-HCl, 0.5M EDTA, 6M guanidinium hydrochloride [GuHCl], 0.5% [w/v] Triton X-100) and 250µl milli-Q water were added. For DNA extraction from legs, the samples were crushed in lysis buffer using knotes pestles after which milli-Q water was added. Subsequently, 50µl Proteinase K was added and incubated overnight at 60°C in a thermoblock shaking at 1400 rpm. The following morning the process was continued by the addition of 40µl diatomaceous earth suspension and incubating at 37°C for 1 hour shaking at 1400 rpm. The tubes were then centrifuged for 20s and supernatant discarded. The pellet was washed two times with 900µl 70% ethanol (4°C) and centrifuged for 20s. Washing involved adding ethanol, mixing, centrifuging and discarding the supernatant. This sequence was repeated two times. This was followed by washing with 900µl acetone (once only). The pellet was dried at 50°C in the thermoblock for 20 min. TE buffer (90µl) was added to the pellet and incubated at 60°C in the thermoblock for 20 min shaking at 1000rpm. This was followed by centrifuging for 40s. Finally the supernatant was transferred by pipetting to new PCR tubes and stored at - 20°C.

### 9.2.3 Amplification

Successful PCR amplification of the target genes was used as a measure of the quality of DNA isolated. We defined amplification success as the production of a visible PCR amplification band of the expected size after agarose gel resolution. The entire ITS2 gene and a fragment of the COI were used to evaluate the quality for molecular work of the DNA extracted. These genes were selected because they have been used for assessing molecular variation and phylogenetic relationships in Rhipicephaline ticks (Barker, 1998; Murrell *et al.*, 2000).

### 9.2.3.1 Primers

ITS2 was amplified using the forward primer 3SAF (5'-CTA-AGC-GGT-GGA-TCA-CTC-GG-3') from Barker (1998) and the reverse primer ITS2R (5'-ATA-TGC-TTA-AAT-TCA-GCG-GG-3') from Domanico *et al.* (1997). COI was amplified with the forward primer CI-J-1718 (5'-GGA-GGA-TTT-GGA-AAT-TGA-TTA-GTT-CC-3') and the reverse primer CI-N-2191 (5'-CCC-GGT-AAA-ATT-AAA-ATA-TAA-ACT-TC-3'), both from Simon *et al.* (1994).

### 9.2.3.2 PCR

PCR for both the ITS2 and COI was set up in a 50µl volume in a thermal cycler (MJ Research; model PTC 100). The 50µl PCR mix contained 0.5pmoles of each of the respective primers, 3mM MgCl<sub>2</sub>, 0.1Units *Taq* polymerase (QIAGEN<sup>TM</sup>), and 0.2mM of each dNTP. Three µl DNA extract was used as template in the PCR mixture. Positive controls were established and validated for each preservation group. Negative controls (no template) were always run simultaneously. The temperature profile for the amplification of the ITS2 region was 94°C for 1 min, 55°C for 1 min and 72°C for 2 min for 35 cycles. For the COI fragment the profile was 94°C for 1 min, 50°C for 1 min and 72°C for 2 min for 35 cycles. For both profiles an initial denaturation step of 94°C for 3 min and a final extension step of 72°C for 10 min were added. In both cases a heated lid was enabled. After amplification a mixture of 5µl PCR product and 2µl loading buffer were resolved by electrophoresis through 2% (w/v) agarose gel in TAE buffer [pH 8.0] during 20 min at 100V in a Mini Gel migration trough (Cosmo Bio Co. LTD). DNA bands were visualised using the ImageMaster VDS<sup>®</sup> after staining with ethidium bromide for 30 min. Selected amplicons were sent for direct sequencing. This was done by the VIB genetic service facility (University of Antwerp), using the ABI PRISM<sup>®</sup> BigDye<sup>TM</sup> Terminator cycle sequencing kit and a capillary DNA sequencer (Applied Biosystems 3730 DNA Analyzer).

## 9.2.4 Statistical analysis

Data analysis was done in Stata SE/8.0 (StataCorp. 2003). Using logistic regression (LR) we related the success of amplification (response variable) to the independent variables namely, gene segment, extraction method, preservation and all the possible interactions of these variables. Starting from this saturated model, non significant interactions were removed and the simpler models were interpreted.

The first simpler LR analysis related amplification success (response variable) to the four sample preservation methods, two DNA extraction methods and two target genes as independent variables. Refrigerator samples were not included since these were not used with both extraction methods. In the second LR we related the amplification success of DNA template of specimens from all the five preservation methods isolated using DNA extraction method 3 to the two target genes. The last LR related the amplification success of the ITS2 to each of the five preservation methods for DNA template from legs obtained by extraction method 3.

### 9.3 Results

Results of the amplification success of ITS2 and COI for the five preservation methods are summarised in table 9.1.

**Table 9.1: PCR amplification success of the ITS2 and COI of adult *R. appendiculatus* for five preservation methods and two DNA extraction methods**

Extraction Method	Preservation Method	Gene					
		Amplification	ITS2 Total	% Amplification	Amplification	COI Total	% Amplification
<b>Method 2</b>	Fresh	28	30	93	30	30	100
	Cryopreserved	3	30	10	0	30	0
	70% Ethanol	11	30	37	4	30	13
	Dried	1	30	3	0	30	0
	Refrigerator	Not done	-	-	Not done	-	-
	<b>Total</b>	<b>43</b>	<b>120</b>		<b>34</b>	<b>120</b>	
<b>Method 3</b>	Fresh	30	30	100	30	30	100
	Cryopreserved	27	30	90	22	30	73
	70% Ethanol	26	30	87	22	30	73
	Dried	0	30	0	0	30	0
	Refrigerator	27	28	96	27	28	96
	<b>Total</b>	<b>110</b>	<b>148</b>		<b>101</b>	<b>148</b>	

The first LR analysis showed that fresh ticks had a significantly higher success of amplification than ticks preserved by 70% ethanol, cryopreservation and drying. There was no significant difference ( $p=0.061$ ) in amplification success between specimens preserved in 70% ethanol and cryopreserved specimens. Extraction method 1 failed with all preservation methods. Template obtained by extraction method 3 had a significantly higher success of amplification than that obtained by method 2. ITS2 had a significantly higher ( $p<0.001$ ) success of amplification than COI.

Results of the second LR showed that fresh ticks had the highest amplification success in both gene segments. This was followed by refrigerator samples. There was

no significant difference ( $P=0.814$ ) between cryopreservation and 70% ethanol preservation. There was no significant difference ( $P=0.051$ ) in success of amplification between ITS2 and COI.

The results of the legs only analysis (Table 9.2) showed that fresh ticks and refrigerator samples had the highest success of amplification followed by cryopreservation and 70% ethanol preserved specimens between which there was no significant difference.

**Table 9.2: PCR amplification success of the ITS2 from DNA template obtained by extraction method 3 from legs of adult *R. appendiculatus* preserved in five different ways**

Preservation Method	Number Amplified	Total	Percent Amplification
Fresh	15	15	100%
Refrigerator	15	15	100%
Cryopreservation	5	15	33.3%
70% Ethanol	4	15	26.7%
Dried	2	15	13.3%

Amplicons from legs like those from whole body yielded interpretable sequences (not presented) after sequencing.

## 9.4 Discussion

Preservation is critical in the study of variation as it allows for investigations over wider temporal and spatial ranges of the targeted species. However, preservation methods differ both in their effectiveness and practicality.

Fresh specimens yielded the highest quality of DNA for PCR. This was evidenced by consistent significantly higher amplification success for the two gene segments and extraction methods respectively. Nevertheless, the availability of specimens killed just before processing is not practical due to limitations like the large numbers of specimens that may have to be processed, the inherently low throughput of some of the methods of processing specimens, the large geographical area over which samples may have to be collected (making direct processing difficult), and the necessity of analysing preserved specimens from old museum collections. All these conditions require the use of preserved ticks. In the first LR, fresh specimens were followed by 70% ethanol and cryopreservation with no significant difference in the success of



amplification of the latter two. This was unexpected since, time of storage has been observed to be more critical for PCR success than storage conditions (Dean and Ballard, 2001). Ethanol (70%) samples were stored for about 10 years, while cryopreserved samples for approximately two years. In addition, our observation is at variance with observations in insects, where cryopreservation was reported to be the best preservation method for molecular work (Cruickshank, 2002). The apparent lack of superiority of cryopreservation over 70% ethanol may be due to the release of cellular endonucleases during thawing which might have resulted in degradation of some nucleic acids. Endonucleases are ubiquitous, difficult to inactivate especially in moist conditions and very minute quantities are sufficient to destroy nucleic acids. Freezing generates crystals which destroy cellular compartments where endogenous DNA-damaging nucleases are sequestered giving them access to nucleic acids during thawing (Dean and Ballard, 2001; Burgemeister *et al.*, 2003). Though manipulation of cryopreserved samples (-80°C) was done on ice (0-4°C) some thawing may have taken place.

Similar results were obtained in the second LR, which included samples from the refrigerator. In this analysis, however, refrigerator samples had the next highest success of amplification after the fresh samples. An earlier observation that specimens killed in 100% ethanol and stored at or below 4°C produce the best results (Dillon *et al.*, 1996) is consistent with this result. The relatively higher amplification success of refrigerator samples may be attributed to their shorter period of storage, approximately a year. However, going by this pattern alcohol preserved ticks should have had the least success since they were the oldest. Instead it was dried ticks that yielded the least amplification results. Drying as a preservation method for material for DNA work has been previously reported by Cruickshank (2002) to be unsuitable for another group of Acari, the mites. Our results with *R. appendiculatus* are congruent with that observation.

Generally there was higher PCR amplification success of ITS2 than COI. It is not clear why COI had lower amplification success. We speculate that this may be due to the wobble of the third codon positions in COI which may have resulted in more failures of primer annealing. The difference in amplification success between ITS2 and COI was significant ( $p < 0.001$ ) in the first LR. However, with extraction method 3

(i.e. second LR) there was no significant difference ( $p=0.051$ ) between the PCR amplification success of ITS2 and COI.

It has been reported that rRNA genes are present in all cells facilitating PCR from small or degraded samples (Barker, 1998). Indeed, successful PCR amplifications of the ITS2 from leg extracts was possible and the pattern of amplification success was similar to that of whole tick extractions. Fresh and refrigerator samples yielded the highest amplification success followed by cryopreservation and 70% ethanol preservation. Amplification of DNA from leg extracts could be useful in experiments involving e.g. fed ticks reducing the risk of having PCR inhibition due to presence of tick's blood meal. Secondly tick DNA extracted from legs could be used as (quality) controls during studies where *R. appendiculatus* intracellular pathogen DNA in other body parts from the same individual is the target. Lastly using legs could allow for preservation of taxonomically more important tick body parts (i.e. in type material and for future type designations).

Unlike extraction methods 2 and 3, method 1 did not yield any successful amplification not even in fresh ticks. The failure of method 1 to produce any successful PCR amplification could have been due to the absence of a step in the protocol to get rid of exoskeletal and cellular debris (Hill and Gutierrez, 2003) and PCR inhibitors especially blood constituents. According to Higuchi, (quoted in Hubbard *et al.*, 1995) whole blood (from tick blood meals) can inhibit DNA amplification even when present in very small quantities (1% v/v). In contrast, method 2 performed very well with fresh samples. However, the performance of this method reduced drastically when applied to preserved samples. This may be due to the yet unexplained susceptibility of tick DNA to degradation after ethanol precipitation (Hill and Gutierrez, 2003). This phenomenon, combined with some degree of degradation caused by the preservation method itself, may have resulted in reduced amplification success. The difficulty of re-dissolving the DNA pellets obtained by method 2 due to co-purification with glycogen, as reported by Hill and Gutierrez (2003), could also have contributed to the lower performance. Method 3 yielded a significantly higher amplification success than the other extraction methods with all preservation methods, except with dried specimens. This agrees with findings of Hubbard *et al.* (1995), and extends the usefulness of this method to preservation methods other than alcohol. The PCR amplification of template and subsequent

satisfactory sequencing of amplicons obtained is, nevertheless, not a reflection of the molecular weight and quantity of total genomic DNA obtained. Determination of these and an extraction method for obtaining high molecular weight genomic DNA for ticks have been described by Hill and Gutierrez (2003). PCR amplification success only confirms the suitability of DNA extracted for the purpose. The experiments with extraction methods 1 and 2 (validated for mosquitoes) confirm the observation that the usefulness of preservation and extraction methods may not simply be extrapolated between different taxa (Dillon *et al.*, 1996). Further, they showed that DNA extraction protocols should be evaluated and optimised in function of preservation methods of specimens.

Within the limits of this study we can conclude that different preservation methods vary in quality of DNA produced for PCR. Fresh ticks are the best but are logistically not easy to obtain. Killing ticks in alcohol and storing in the refrigerator may be equally a very effective mode of preservation for DNA work at least for shorter preservation periods. This was evident in both whole tick and tick legs extract. Ethanol preservation may be as good as cryopreservation. Since the latter is not always practicable (Cruickshank, 2002) the former could therefore be useful when ticks have to be collected in harsh field conditions in regions where the cold chain may not be guaranteed or even impossible to maintain. However, this may need confirming by comparing samples of similar storage age preserved by different methods for different storage periods. The effect of the target gene on the amplification success was not evident at least when the tick validated DNA extraction method was used. That the sequences of amplicons from leg DNA were as interpretable as those from whole body amplicons is significant and to our knowledge this is the first time DNA template from legs of ticks was amplified and sequenced.

## 9.5 References

- Barker, S.C. 1998. Distinguishing species and populations of Rhipicephaline ticks with ITS 2 ribosomal RNA. *Journal of Parasitology*, 84, 887-892.
- Boom, R., C.J.A. Sol, M. M. M. Salimans, C.L. Jansen, P.M.E. Wertheim-van Dillen and J. Van Der Noordaa. 1990. Rapid and simple method of purification of nucleic acids. *Journal of Clinical Microbiology*, 28, 495-503.
- Boom, R., C. Sol, M. Beld, J. Weel, J. Goudsmit and P. Wertheim-van Dillen. 1999. Improved silica-guanidiniumthiocyanate DNA isolation procedure based on selective binding of bovine alpha-casein to silica particles. *Journal of Clinical Microbiology*, 37, 615-619.
- Burgemeister, R., R. Gangnus, B. Haar, K. Schütze and U. Sauer. 2003. *Pathology Research and Practise*, 199, 431-436.
- Collins, F.H., M.A. Mendez, M.O. Rasmussen, P.C. Mehaffey, N.J. Besansky and V. Finnerty. 1987. A ribosomal RNA gene probe differentiates member species of *Anopheles gambiae* complex. *American Journal of Tropical Medicine and Hygiene*, 37, 37-41.
- Crampton, A., I. McKay and S.C. Barker. 1996. Phylogeny of ticks (Ixodida) inferred from nuclear ribosomal DNA. *International Journal of Parasitology*, 26, 511-517.
- Crosbie, P.R., W.M. Boyce and T.C. Rodwell. 1998. DNA sequence variation in *Dermacentor hunteri* and estimated phylogenies of *Dermacentor* spp. (Acari: Ixodidae) in the New world. *Journal of Medical Entomology*, 35, 277-288.
- Cruickshank, R.H. 2002. Molecular markers for the phylogenetics of mites and ticks. *Systematic and Applied Acarology*, 7, 3-14.
- Dean, M.D. and J.W.O. Ballad. 2001. Factors affecting DNA quality from museum preserved *Drosophila simulans*. *Entomology Experimental and Applied*, 98, 279-283.
- Dillon, N., A.D. Austin and E. Bartowsky. 1996. Comparison of preservation techniques for DNA extraction from hymenopterous insects. *Insect Molecular Biology*, 5, 21-24
- Domanico, M.J., R.B. Phillips and T.H. Oakley. 1997. Phylogenetic analysis of pacific salmon (genus *Oncorhynchus*) using nuclear and mitochondrial DNA sequences. *Canadian Journal of Fish and Aquatic Sciences*, 54, 1865-1872.
- Guglielmo, A.A., A. Estrada-Peña, A.J. Mangold, D.M. Barros-Battesti, M.B. Labruna, J.R. Martins, J.M. Venzal, M. Arzua and J.E. Keirans. 2003. *Amblyomma aureolatum* (Pallas, 1772) and *Amblyomma ovale* Koch, 1844 (Acari: Ixodidae): hosts, distribution and 16S rDNA sequences. *Veterinary Parasitology*, 113, 273-288.
- Hernandez, R., A.C. Chen, R.B. Davey, G.W. Ivie, G.G. Wagner and J.E. George. 1998. Comparison of genomic DNA in various strains of *Boophilus microplus* (Acari: Ixodidae). *Journal of Medical Entomology*, 35, 895-900.

- Hill, C.A and J.A. Gutierrez. 2003. A method for extraction and analysis of high quality genomic DNA from ixodid ticks. *Medical and Veterinary Entomology*, 17, 224-227.
- Hubbard, M.J., K.J. Cann and D.J.M. Wright. 1995. Validation and rapid extraction of nucleic acids from alcohol-preserved ticks. *Experimental and Applied Acarology*, 19, 473-478.
- Mangold, A.J., M.D. Barques and S. Mas-Coma. 1998. 18S rRNA gene sequences and phylogenetic relationships of European hard-tick species (Acari: Ixodidae). *Parasitology Research*, 84, 31-37.
- McLain, D.K., D.M. Wesson, J.H. Oliver Jr. and F.H. Collins. 1995. Variation in ribosomal DNA internal transcribed spacers 1 among eastern populations of *Ixodes scapularis* (Acari: Ixodidae). *Journal of Medical Entomology*, 32, 353-360.
- Murrell, A., N.J.H. Campbell and S.C. Barker. 2000. Phylogenetic analyses of the rhipicephaline ticks indicate that the genus *Rhipicephalus* is paraphyletic. *Molecular Phylogenetics and Evolution*, 16, 1-7.
- Murrell, A., N.J.H. Campbell and S.C. Barker. 2001. Recurrent gains and losses of large (84-109bp) repeats in the rDNA internal transcribed spacer 2 (ITS2) of rhipicephaline ticks. *Insect Molecular Biology*, 10, 587-596.
- Phillips, A.J. and C. Simon. 1995. Simple, efficient and non-destructive DNA extraction protocol for arthropods. *Annals of the Entomological Society of America*, 88, 281-283.
- Simon, C., F. Frati, A. Beckenbach, B. Crespi, H. Liu and P. Flook. 1994. Evolution, weighting and phylogenetic utility of mitochondrial gene sequences and a compilation of conserved polymerase chain reaction primers. *Annals of the Entomological Society of America*, 87, 651- 701.
- Speybroeck, N., M. Madder, P. Van Den Bossche, J. Mtambo, N. Berkvens, G. Chaka, M. Mulumba, J. Brandt, L. Tirry and D. Berkvens. 2002. Distribution and phenology of ixodid ticks in southern Zambia. *Medical and Veterinary Entomology*, 16, 430-441.
- StataCorp. 2003 *Stata/SE 8.0 for Windows statistical software*, Stata Corporation, College Station, Texas.



**Chapter 10 - Is *RHIPICEPHALUS ZAMBEZIENSIS*  
PRESENT IN EASTERN PROVINCE? APPLICATION OF  
THE PCR-*BAUI* IDENTIFICATION TOOL TO A  
COLLECTION OF SPECIMENS OF *RHIPICEPHALUS* SPP.  
FROM EASTERN PROVINCE**

## 10.1 Introduction

Expert opinion on the presence or absence of *R. zambeziensis* in Eastern province is divided. The species was reported in the province by early workers, for example Norval *et al.* (1982) has reports of the species in Chipangali of Chipata and MacLeod and Mwanaumo (1978) reported the species in the Luangwa Valley. On the contrary, Berkvens *et al.* (1998) are inclined to think some of these reports would be due to the misidentification of *R. zambeziensis* like specimens that are, however, *R. appendiculatus*. These *R. zambeziensis* like specimens are common on the Eastern province plateau especially at lower altitude. On average Eastern province *R. appendiculatus* ticks are of a smaller adult body size compared to the stocks from Southern province and generally southern African specimens (Speybroeck *et al.*, 2004). Also, by definition *R. zambeziensis* is a small tick compared to *R. appendiculatus*. This size complication coupled with increased punctation and intermediate forms (between V-form and U-form) of the female genital aperture in lower altitude specimens of *R. appendiculatus* may be the source of the confusion (Berkvens *et al.*, 1998). The picture is further complicated by the fact that, like *R. zambeziensis*, Eastern province *R. appendiculatus* specimens may not exhibit behavioural diapause (Berkvens *et al.*, 1995). However, since the general ecological conditions obtaining in the Eastern province are similar to those in the Southern province (Mtambo *et al.*, 2007a) it is therefore, a reasonable supposition that *R. zambeziensis* may be present in Eastern province just as in Southern province. The presence of *R. zambeziensis* in Eastern province has important ramifications on the epidemiology of East Coast fever, at least that is what has been observed in Southern province (Mulumba *et al.*, 2000).

Therefore the aim of this work was to identify, using the PCR-RFLP *BauI* tool any *R. zambeziensis* specimen in a collection of ticks morphologically identified as *Rhipicephalus* spp. from three Eastern province districts.

## 10.2 Materials and Methods

### 10.2.1 Study area

The Eastern province of Zambia is located at (10°18-15°06S; 29°56-33°42E). It falls into agro ecological zones 1 and 2a (Mtambo *et al.*, 2007a). Vegetation and climatic



conditions in the province have been described in (Berkvens *et al.*, 1998; Mtambo *et al.*, 2007a).

### 10.2.2 Ticks

Ticks in the Eastern province were collected in January of 2003 from the plateau districts of Chipata in villages of Kamulaza and Wafa, Petauke in the villages of Kalindawalo and Nyamphande and, Nyimba in the villages of Beni and Chipembi. Nyimba is a district bordering the Luangwa valley. These specimens were killed and preserved at  $-80^{\circ}\text{C}$ . For the current work a total of 300 ticks, 100 from each district and therefore 50 for each village were identified as *Rhipicephalus* spp. based on morphological keys of walker *et al.*, 2000. Morphological identification of the specimens and any other manipulations were done on ice to avoid thawing and hence breakdown of DNA.

### 10.2.3 Molecular techniques

Extraction of DNA and amplification by PCR were reported in Mtambo *et al.* (2006). Specimens were put on ice during DNA extraction manipulations. DNA for reference specimens was extracted from *R. appendiculatus* and *R. zambeziensis* material from a colony in Onderstepoort Veterinary Institute (OVI) in Pretoria identified by Jane Walker (OVI, Pretoria).

The digestion of the ITS2 amplicon was done with the restriction endonuclease *BauI* (see table 10.1 for details of *BauI*).

**Table 10.1: Details of the restriction endonuclease *BauI***

Full name	Abbreviated name	Recognition sequence	Cleavage Type
<i>Bacillus aquaemaris</i>	RFL1	5'-C <sup>^</sup> A C G A G-3' 3'-G T G C T <sup>^</sup> C-5'	Sticky end

Each sample (ITS2 PCR amplicon) for each specimen DNA was digested in a 25 $\mu\text{L}$  volume containing 17 $\mu\text{L}$  Mqw, 2.5 $\mu\text{L}$  10X buffer (Tango<sup>TM</sup>) (Fermentas, Life Sciences), 0.5 $\mu\text{L}$  enzyme (0.1U *BauI*) and 5 $\mu\text{L}$  of the sample amplicon in that order. When Mqw, buffer and enzyme were added, the mixture was gently vortexed before addition of the amplicon. After addition of the amplicon the mixture was short centrifuged and incubated at  $37^{\circ}\text{C}$  for 150 min. The fragment profiles were resolved by electrophoresis as reported in Mtambo *et al.* (2007b).

### 10.3 Results

All the 300 samples tested had a profile of *R. appendiculatus* upon resolution in 2% agarose gel of the *BauI* digested ITS2 amplicon.

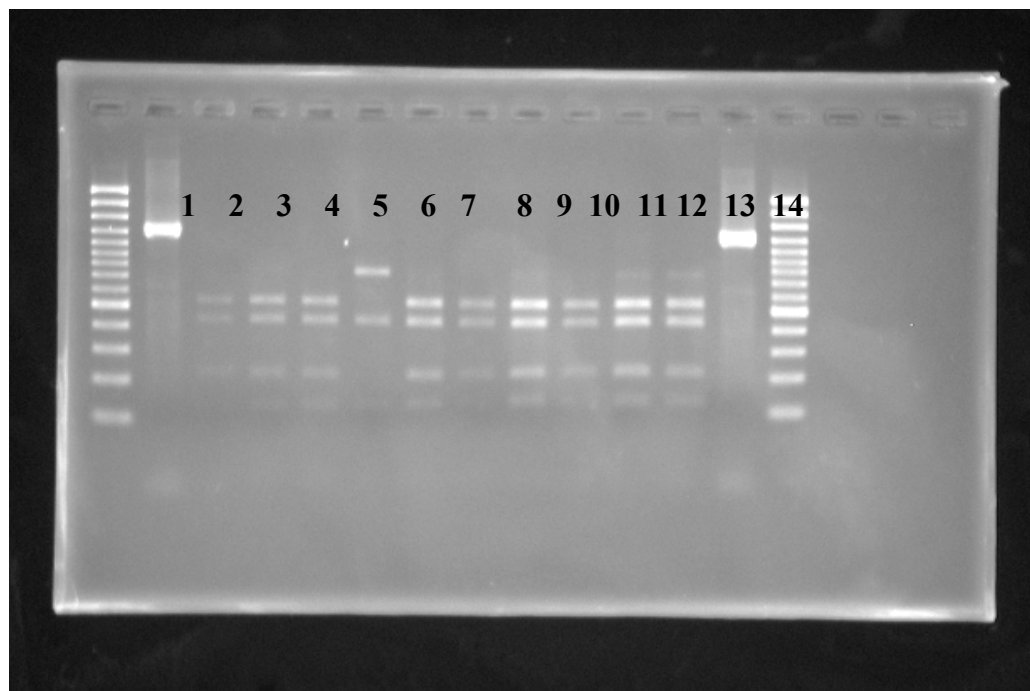

**Fig.10.1: Resolution of *BauI* digested ITS2 on 2% agarose gel for ticks from Eastern province. Lanes 1 and 14, 100+bp ladder; Lane 2 undigested ITS2 amplicon for *R. appendiculatus* (1150bp); Lane 13, undigested ITS2 amplicon for *R. zambeziensis* (1150bp); Lane 6, *R. zambeziensis* reference specimen restriction fragment pattern; Rest of Lanes, *R. appendiculatus* reference and test specimens restriction fragment profile.**

### 10.4 Discussion

The small adult body size of *R. appendiculatus* found in Eastern province (Speybroeck *et al.*, 2004) and the presence of *R. appendiculatus* specimens morphologically near *R. zambeziensis* (Berkvens *et al.*, 1998) makes for very difficult morphological discrimination of the two taxa in this area. In this study this morphological discrimination was made more difficult by the distortions in the morphology of the specimens by the preservation mode, cryopreservation. Firstly, cryopreservation tends or at least tended to shrink the specimens, making the already small specimens smaller. Secondly cryopreserved ticks were very fragile, resulting in loss of appendages in most specimens. These distortions in a sense worked as a blind because none of the specimens could with confidence be designated as, *R. appendiculatus*, or *R. appendiculatus* near *R. zambeziensis* (i.e. morphological

intermediates), the morphological groups that have been described in the area (Berkvens *et al.*, 1998).

Only *Rhipicephalus appendiculatus* profiles were observed in all the three hundred specimens examined pointing to the rarity, if present, of *R. zambeziensis* in the three districts (six villages) sampled. This is in agreement with observations of an earlier study (Mtambo *et al.*, 2007b) where, all specimens morphologically misidentified as *R. appendiculatus* and later re-identified as *R. zambeziensis* by molecular methods came from the Southern province. However, the presence of *R. zambeziensis* in the Eastern province cannot be ruled out by the current study as it is inconclusive since no specimens were collected from the areas like Chipangali where reports of the species exist. There is need for further sampling including the areas where reports of the species exist. Indeed the ecological conditions in Eastern province are comparable to those of the Southern province (Mtambo *et al.*, 2007a) that support this species. This is important first for the study of ecology of this tick as its presence in the province has been questioned. Secondly it is important that the presence or otherwise is determined because of the different influences this tick brings to the epidemiology of ECF.

## 10.5 References

- Berkvens, D.L., R.G. Pegram and J.R.A. Brandt. 1995. A study of the diapausing behaviour of *Rhipicephalus appendiculatus* and *R. zambeziensis* under quasi-natural conditions in Zambia. *Medical and Veterinary Entomology*, 9, 307-315.
- Berkvens, D.L., D.M. Geysen, G. Chaka, M. Madder and J.R.A. Brandt. 1998. A study of ixodid ticks parasitizing cattle in the Eastern province of Zambia. *Medical and Veterinary Entomology*, 12, 234-240.
- MacLeod, J. and B. Mwanaumo. 1978. Ecological studies of ixodid ticks (Acari, Ixodidae) in Zambia IV. Some anomalous infestations in the northern and eastern regions. *Bulletin of Entomological Research*, 68, 409-429.
- Mtambo, J., W. Van Bortel, M. Madder, P. Roelants and T. Backeljau. 2006. Comparison of preservation methods of *Rhipicephalus appendiculatus* (Acari: Ixodidae) for reliable DNA amplification by PCR. *Experimental and Applied Acarology*, 38, 189-199.
- Mtambo, J., M. Madder, W. Van Bortel, D. Berkvens, G. Chaka and T. Backeljau. 2007a. Further evidence for geographic differentiation in *R. appendiculatus* (Acari: Ixodidae) from Eastern and Southern provinces of Zambia. *Experimental and Applied Acarology*, 41, 129-138.
- Mtambo, J., M. Madder, W. Van Bortel, D. Berkvens and T. Backeljau. 2007b. *Rhipicephalus appendiculatus* and *R. zambeziensis* (Acari: Ixodidae) from Zambia: a molecular reassessment of their species status and identification. *Experimental and Applied Acarology*, 41, 115-128.
- Mulumba, M., N. Speybroeck, M. Billiouw, D.L. Berkvens, D.M. Geysen and J.R. Brandt. 2000. Transmission of *Theileria parva* in the traditional farming sector in the Southern province of Zambia during 1995-96. *Tropical Animal Health and Production*, 32, 303-314.
- Norval, R.A.I., J.B. Walker and J. Colborne. 1982. The ecology of *Rhipicephalus zambeziensis* and *Rhipicephalus appendiculatus* (Acarina, Ixodidae) with particular reference to Zimbabwe. *Onderstepoort Journal of Veterinary Research*, 49, 181-190.
- Speybroeck, N., M. Madder, H.H. Thulke, J. Mtambo, L. Tirry, G. Chaka, T. Marcotty and D. Berkvens. 2004. Variation in body size in the tick complex *Rhipicephalus appendiculatus/Rhipicephalus zambeziensis*. *Journal of Vector Ecology*, 29, 347-354.

## **Chapter 11 - GENERAL DISCUSSION**

## 11.1 Introduction

The current methods of ECF control rely heavily on reduction of the vector ticks through the use of acaricides. These have had limited efficacy on the control or eradication of the disease. To begin with, this is due to the inherent problems of acaricide use that include high cost and selection of acaricide resistant ticks (Dolan, 1999; de la Fuente and Kocan, 2003; Walker, 2007; Kivaria *et al.*, 2007) and creation of endemic instability (Billouw, 2005). The creation of endemic instability by acaricide is a very important problem especially in the cattle management system practised in the traditional livestock sector of Zambia where herds are mixed at pasture. Clean herds (endemically unstable) must inevitably get infested (infected) unless all the farmers practiced the tick control regimens with equal stringency. Secondly, the sheer complexity of the epidemiology ECF (Billouw *et al.*, 1999; Billouw *et al.*, 2002; Fandamu *et al.*, 2005a; Fandamu *et al.*, 2005b) condemns the use of acaricide to this limited efficacy, at least in the traditional management system practised in Zambia. This situation begs for alternative methods of control that are justifiably being considered that include, immunization by an infection and treatment method (ITM), immunization using antigens against *T. parva* e.g. circum-sporozoite antigen protein (p67) (Musoke *et al.*, 2005; Kaba *et al.*, 2005), development of vaccines against tick infestation (anti-tick vaccines) e.g. the 15kDa *Rhipicephalus appendiculatus* tick protective antigen 64P (Trimnell *et al.*, 2002). Genetic methods are used in the development of anti-tick vaccines using gene sequences encoding protective antigens as genetic markers for studying the phylogenetic relatedness of tick strains (de la Fuente and Kocan, 2003). Identification and development of genetic methods of control in general must be preceded by an appreciation of genetic variation in the taxa of concern. This is necessary for the purposes of identifying or eliminating errors arising from taxonomical uncertainties introduced by variation (Gooding, 1996).

Variation in many species and species complexes has been better resolved by the use of genetic tools and techniques (Mcmichael and Hall, 1996; Pascual *et al.*, 1997; Hernandez *et al.*, 1998; de la Fuente *et al.*, 2005; Le Goff *et al.*, 2006; Perrin *et al.*, 2006). Of these techniques it, has been observed that direct sequencing of DNA provides the highest detail of variation (Navajas and Fenton, 2000; Ridley, 2004). In addition, molecular data permits the use of more sophisticated methods of

phylogenetic reconstruction than morphological methods (Cruickshank, 2002). Phylogeny on the other hand provides a better principle for biological classification than any alternatives (Ridley, 2004). See Sokal (1994) for an alternative view. Therefore, the use of phylogenetic methods to analyse molecular data of *R. appendiculatus* and *R. zambeziensis* promises to shed more light on the extent of diversity in both taxa and consequently perhaps some insights into the epidemiology of ECF the disease they transmit.

The aim of the studies reported in this work was to describe genetic and phenotypic variation in *R. appendiculatus/zambeziensis* complex in eastern and southern Zambia where different morphological, ecological and ethological groups have been reported (Berkvens *et al.*, 1995; Berkvens *et al.*, 1998; Chaka *et al.*, 1999; Madder *et al.*, 2002; Speybroeck *et al.*, 2002). The different groups are associated with different epidemiology of ECF (Billiouw *et al.*, 1999; Mulumba *et al.*, 2001, 2000; Speybroeck *et al.*, 2002; Billiouw, 2005). The data were to be used in assessing the relatedness of the groups of the complex using phylogenetic methods.

To accomplish this aim we first assessed intra and interspecific phenotypic variations between *R. appendiculatus* and *R. zambeziensis* by comparing morphological characters and life cycle traits. Intraspecific genetic variation was investigated by comparing sequencing of the mitochondrial COI and mitochondrial 12S rDNA. On the other hand interspecific genetic variation was investigated analysis of the second internal transcribed spacer (ITS2) of the nuclear genes. The Phylogenetic species concept (see section 2.4.5) was chosen as the guiding concept in the event where a decision needed to be made as to whether the variation encountered was due to the crossing of a species boundary. If indeed evolution within a species may be defined as change within a lineage of a population between generations (Ridley, 2004), then any heritable diagnosable change in character state of important ecological or epidemiological consequence in comparable individuals must be accounted for. The practical aspects of what to call the revealed clusters need not be an issue as most specimens can be fitted into conventionally recognized species in the majority of cases (Ridley, 2004). Granted the revealed groups may later merge or even become further differentiated, still nothing is lost to the evolutionary biologists as the history of the organism will have been documented and the processes that accounted for that change investigated. Another aim of these studies was to develop a molecular tool for

the identification of *R. appendiculatus* and *R. zambeziensis* and groups within *R. appendiculatus*. It was important for us to do so because of the difficulty of morphologically distinguishing between the two species and between the different groups within *R. appendiculatus*, which nevertheless have different effects on the epidemiology of ECF. An identification tool would also help in settling the question of whether *R. zambeziensis* s.s. and not *R. zambeziensis*-like specimens are present in Eastern province. But a tool for the identification *R. zambeziensis* and *R. appendiculatus* exists already in the form of Glucosephosphate Isomerase (GPI EC.5.3.1.9) enzyme electrophoresis zymograms. But the Achilles' heel of the current tool is that it will only work with fresh or cryopreserved samples. Therefore before another tool could be developed, we explored the ability of ticks preserved by methods more practical than cryopreservation (in the Zambian context) to yield DNA useful in PCR techniques.

The following sections will discuss the main findings and implications of our studies which are mainly descriptive. By and large each section is discussed under two latent heads of ecology and evolution of the two vector ticks, and epidemiology of ECF. The first section (11.2) examines the results of the assessment of phenotypic variation in *R. appendiculatus* and *R. zambeziensis* from Zambia in the presence of two control stocks of the same species from South Africa. The section that follows (section 11.3) discusses the results of genetic intraspecific variation of different morpho-eco-ethological groups of *R. appendiculatus* from Zambia and suggests possible reasons for the variation observed. Section 11.4 discusses intraspecific genetic variation of *R. appendiculatus* group from Zambia to some stocks beyond the northern and southern borders of Zambia i.e. to the north and south of the distribution range of the tick species and provides possible colonization scenarios. The next section (section 11.5) is a summary of observations in the genetic intraspecific variation of *R. zambeziensis*. After exploration of intraspecific variation (sections 11.3 to 11.5) in the different groups, section 11.6 deals with the relationships of the different groups in the *R. appendiculatus/ zambeziensis* complex. The next section (11.7) is an intervening section before development of a molecular tool for discriminating between *R. appendiculatus* and *R. zambeziensis* (section 11.8). This section (11.7) discusses results of the comparison of different methods of preserving *R. appendiculatus* material for the quality of DNA isolated for PCR techniques. The



last section (11.9) is a report of the application of the PCR-RFLP tool to a collection of morphologically identified *Rhipicephalus* spp. specimens from Eastern province. The discussion ends with conclusions and prospects for future research.

## **11.2 Phenotypic variation in *R. appendiculatus* and *R. zambeziensis* stocks from Zambia**

Phenotypic characters of three stocks of *Rhipicephalus* spp. from Zambia were compared in the presence of two stocks from South Africa that were used as reference stocks. The first stock was *R. appendiculatus* from Wafa village in Chipata, an area where the tick shows two adult phenology (Berkvens *et al.*, 1995; Chaka *et al.*, 1999) and the epidemiology of ECF has been described as being at first level endemically stable state (Billiouw, 2005). The second stock came from Nkonkola village in Mazabuka where *R. appendiculatus* occurrence has been described as “pure” (that is not mixed with *R. zambeziensis*). The epidemiology of ECF is described as epidemic ((Billiouw, 2005). East Coast fever cases in pure *R. appendiculatus* areas tend to be restricted to the rainy season, the period of peak adult activity (Mulumba *et al.*, 2001). The third stock was *R. zambeziensis* from Keemba in Monze, an area described as mixed *R. appendiculatus*/*R. zambeziensis* area. The epidemiology of ECF in Keemba is epidemic, like in Nkonkola. Occurrence of cases of ECF in this area varies with amount and length of the rainy season. In wet years *R. appendiculatus* nymphal to adult transmission is more pronounced with peak of ECF cases occurring in the rainy season during adult activity (Mulumba *et al.*, 2001). In years with below average rainfall, higher vectorial competence of *R. zambeziensis* nymphs accounts for the main larva to nymph transmission with cases occurring in June-July (Mulumba *et al.*, 2000).

Morphology continues to be the first diagnostic tool that is used to discriminate species and groups within a species. Therefore, morphological features of the three ticks were compared for possible distinction while the life cycle traits were studied to compared for both identification purposes and understanding their ecologies.

The three stocks showed differences in their morphologies, chief of which was a difference in adult body size as inferred from scutal length. The Nkonkola stocks had the largest mean adult body size and Keemba the smallest. The Wafa stock had a mean adult body size intermediate between Nkonkola and Keemba. Body size is associated with a number of important ecological traits for a species (Esperk and

Tammaru, 2004). In mosquitoes, body size has been linked with fecundity, spatial dispersal and host attack rate (Gleiser *et al.*, 2000). Body size has also been associated with generation time and metabolism. Speybroeck *et al.* (2004) suspect a link between adult body size and diapause in *R. appendiculatus*. Large ticks are associated with diapause, the large body enabling them to survive hotter and drier environmental conditions obtaining during the period of diapause. Earlier, Madder (1999) surmised that the correspondence between body size and diapause in tick stocks from Zambia was a chance occurrence. Indeed Speybroeck *et al.* (2004) have cautioned on the effect of environmental conditions on body size variation in specimens collected from different localities. Variable as they were, the morphological characteristics we studied were not found to be good markers for the identification of the three tick stocks. Their usefulness is expected to be even lower in field stocks where the rearing conditions are highly variable and with them the morphological characteristics. Therefore, animal health providers and researchers in tick ecology in southern Zambia should always be aware of the fact that collections of morphologically identified *R. appendiculatus* or *R. zambeziensis* are likely to be a mixture of both species.

The life cycle traits of three stocks (Keemba, Nkonkola and Wafa) had varied adult engorgement periods, eclosion periods and duration of nymphal moults. We speculate that, among the life cycle stages we studied, the variable stages might be the ones that may be imbued with life cycle control mechanisms mainly concerned with risk averting. The control mechanisms may be genetically predetermined or prompted by the interaction between genotype and environmental factors. Such mechanisms might therefore be absent in the larval stage where both the engorgement and moulting periods were the same for the three stocks. The Keemba stock had the most extended adult engorgement and egg eclosion profiles. This is likely to lead to longer generation cycles. This consistent with other observations on *R. zambeziensis* in general (Zivkovic *et al.*, 1986) and Keemba stock in particular (Madder *et al.*, 2005).

Eclosion in the Keemba stock started the earliest and lasted the longest. It proceeded slowly with only a small proportion of eggs hatching per day. This, together with extended engorgement periods, might be the major points of modulation of the Keemba cycle in the absence of diapause. It is confounding though why the highly risk-prone eggs could “delay” that long before getting to the next instar. The extended engorgement and slow eclosion might partly explain why adult *R. zambeziensis*

infestation levels are low, and why they continue feeding well after adult *R. appendiculatus* activity has ended. This period might even be longer in nature because rearing conditions are not always optimal. This epidemiologically, may translate in low numbers (abundance) of ticks feeding for a more extended period and theoretically lowered *T. parva* challenge over a longer period (relative to *R. appendiculatus*). But it is also possible that the higher vectorial competence of the nymphs of *R. zambeziensis* may compensate for the low number of feeding adults (Mulumba, 1999).

On the contrary the Nkonkola engorgement and eclosion profile was short. This may translate into increased abundance of adult activity to a very short period within which there is a possibility for very high *T. parva* challenge resulting in increased cases of ECF. Again this period may be longer in nature for the same reasons given earlier. We therefore postulate that *R. zambeziensis* in Southern Zambia in mixed areas might be “a blessing” in disguise, providing a situation for more extended *T. parva* challenge at low doses due to its low abundance thus contributing to the pool of carrier state animals ( see Billiouw, 2005 on conditions for reaching endemic stability). The balance might be disturbed in dry years when climatic conditions favour *R. zambeziensis* survival. Even then we still think *R. zambeziensis* might still remain an “evil –for-good” since in its absence there would be very little challenge in dry years, much like what happens with acaricide control, creating conditions that are suitable for epidemic instability (Billiouw, 2005).

The nymphal moult was similar for all the three stocks. However, there was a cohort of Wafa nymphs that had an accelerated moult. The existence of a two profile nymphal moult for Wafa is consistent with the dichotomy observed in adult body size (Chaka *et al.*, 1999) bimodal phenology (Berkvens *et al.*, 1998) and mixed diapause response (Madder, 1999). We suspect the Wafa cohort that completed the nymphal moult earlier might be the diapausing phenotype and the last to complete the moult the non diapausing phenotype.

Taken together the phenotypic characteristics studied could discriminate between the three stocks.

### 11.3 Genetic intraspecific variation in *R. appendiculatus* stocks from Zambia

*Rhipicephalus appendiculatus* from Eastern and Southern provinces of Zambia have different ecologies. In Eastern province, *R. appendiculatus* have a two adult phenology and their adult body size is described as smaller than Southern province stocks (Berkvens *et al.*, 1998; Chaka *et al.*, 1999). In the Southern province *R. appendiculatus* have a single adult phenology. Their adult body size is described as big (relative to Eastern province) (Speybroeck *et al.*, 2002, 2004).

Sequence analysis of mitochondrial COI data for *R. appendiculatus* revealed two geographically genetically differentiated groups. The two groups did not, however, exactly coincide with the two administrative regions of Eastern and Southern province. Instead one group consisted of specimens from the Southern province and Nyimba, a district of the Eastern province at the south western edge of the province bordering the Luangwa valley. The second group consisted of ticks from the plateau region of the Eastern province.

The geographic genetic variation of the two groups suggests the two are demographically independent populations (Avisé, 2000a). Their demographic independence may be due to geographic or temporal isolation or behavioural differences or a combination of any of these factors. Current geographic isolation may be ruled out since there is neither a geographic nor an ecological “gulf” between their areas of endemicity (Berkvens *et al.*, 1998). Besides, there is free movement of hosts between the two areas (own unpublished observation). Temporal isolation is equally not possible since their phenologies (at least the first wave adults of Eastern province and Southern province adults) are almost the same. However, historical geographical isolation cannot be ruled out (Avisé, 2000; Norval *et al.*, 1991). Therefore a combination of possible historical geographical isolation and current behavioural differences may explain this geographical differentiation (Avisé, 2000). Because of the geographic genetic differentiation and the other ecological differences between these two stocks of *R. appendiculatus*, we suggest the two be considered distinct epidemiological management units (EMU) (Ovenden, 1990; Avisé, 2000b). That is to say, when control strategies of ECF are being considered, identical strategies might not do for both areas (Billiouw, 2005; Speybroeck *et al.*, 2002) because of the underlying difference of the vectors. This differentiation is consistent with their

difference in the competence for *T. parva* (Muguga and Boleni) (Ochanda *et al.*, 1998). It appears that *R. appendiculatus* from the Eastern province has an inherently higher vector competence for *T. parva* as neither Muguga nor Boleni stocks of *T. parva* are from the Eastern province (Norval *et al.*, 1992). In fact the opposite would have been expected, because Muguga has been used in Southern province and Boleni is a southern African stock. *Theileria parva* epidemiological studies done by Nambota *et al.* (1997) and Geysen *et al.* (1999) have shown that the prominent *T. parva* strains in Southern and Eastern provinces are different. This locally distinct nature of the vector parasite relationship gives further credence to for separate EMU status for these ticks. It further gives support for the study of genetic variation in the vector ticks, as this may be a step towards exploration of co-evolution of *T. parva* and *R. appendiculatus/zambeziensis* stocks in their appropriate epidemiological environments.

In addition to implementation of different strategies of ECF control in the two areas (Speybroeck *et al.*, 2002), strict tick control should be practised when moving hosts between the two EMU's areas of endemicity. It is a long established observation that interactions between *T. parva* and *R. appendiculatus* isolated from different geographical origins tend to result in higher infections in the ticks and therefore potentially more severe infections in cattle (Irvin *et al.*, 1989; Norval *et al.*, 1991; Ochanda *et al.*, 1998). However, the challenge in the control of tick on hosts is the control of ticks on wild hosts that move freely between areas. The impossibility to control ticks on wild hosts going by the current institutional and infrastructural set up in Zambia underpins the necessity and urgency with which to understand the biology and ecology of the progeny of the two EMUs in areas of possible contiguity or overlap.

Individual members of the two groups cannot be distinguished morphologically. Currently the two may be differentiated by comparing their mitochondrial COI sequences. However, an RFLP is cheaper and therefore more desirable. Such a tool may be used to both delineate their ranges and identify their areas of contiguity and/or overlap. Such may be used to study the biology and ecology of their progeny and the epidemiology of ECF. Areas of contiguity or overlap might also shed some light on the nature of their intra-species competition.

#### **11.4 Intraspecific genetic variation in *R. appendiculatus* from Zambia compared to stocks from eastern and southern Africa**

Based on their adult body size, phenology, and diapausing behaviour, *R. appendiculatus* stocks from southern Africa through to east Africa have been divided into three groups (Speybroeck *et al.*, 2004). One group consists of southern Africa stocks characterised as large adult body sized with a single adult phenology and an obligate diapause. Within the southern Africa stocks are included *R. appendiculatus* from Southern province of Zambia. The second group consists of the east African stocks that are described as small, with bimodal to multimodal phenologies, and absence of diapause. Between southern and east African stocks are *R. appendiculatus* stocks from the Eastern province described as transition. These are characterised by adult body size that is described as medium, a phenology consisting of two adult waves and a mixed response to diapause depending on climatic conditions (Berkvens *et al.*, 1998; Chaka *et al.*, 1999; Madder *et al.*, 2002).

Analysis of mitochondrial COI and 12S rDNA for *R. appendiculatus* from the three eco-ethological groups of *R. appendiculatus* suggested only two clusters. We have called these clusters the eastern Africa genetic group (eAGG) and the southern African genetic group (sAGG). The eAGG included two ecological groups; the east African and the transition ecological (Eastern province stocks) groups. The sAGG comprised the southern African ecological group.

The data shows that stocks from Eastern province and east Africa or in this case Rwanda are of the same origin, which origin is not known (Madder, 1999). But we can reasonably deduce that the origin of the stock of *R. appendiculatus* from Eastern province which has been a matter of much speculation (Berkvens *et al.*, 1989) is East Africa (See also Dolan, 1999).

If *R. appendiculatus* stocks from Eastern province originated from east Africa, then their ability to undergo a diapause might have been inherited from that stock. However, the diapause phenotype might be very rare in east Africa. This might be because it may not be “desirable”, or it is “costly” (Speybroeck *et al.* 2004) to undergo diapause in east Africa were the bi- or multi-modal rain patterns and temperatures may support all development stages through out the year. Individuals that inherit the diapausing characteristic in populations in east Africa will not contribute as many offspring to subsequent generations over time due to a longer life

cycle, hence their rarity. In Eastern province, the rain pattern is uni-modal. Frequent fluctuations in the length and amount of rain per season in this area might be resulting in the concomitant fluctuations of a comparably higher proportion of individuals that have the non diapausing phenotype than those of the diapausing phenotype. Meaning individuals of the non diapausing phenotype might have a higher variation in fitness in these conditions. Therefore a short rain season will result in reduced survival of non diapausing individuals and therefore less offspring towards the next generation, hence the absence of or non-prominence of one wave of adults the following season. Other things being equal the proportion of diapausing individuals on the other hand may only be reduced in this area by being out-competed by the non diapausing individuals if there are good (long) rainy seasons consecutively for many years.

The variable display of diapause in the Eastern province stock might be a case of genetic polymorphism (see fig.5.4 for partial support for subgroup within the Eastern province and number of haplotypes) and not bet-hedging as suggested by Madder (1999). Bet-hedging is the idea that unpredictably variable environments favour genotypes with lower variance in fitness at the cost of lower arithmetic mean fitness (Seeger and Brockman, 1987; Hopper, 1999). If bet-hedging is the situation in Eastern province then obligate diapausing phenotype should be the favoured phenotype (conservative risk-spreading) or a single genotype should be responsible for the multiple phenotypes (diapause and the non diapause) observed to hedge against the chance of seasonal variation (diversifying risk-spreading) (Hopper, 1999). Indeed, Madder (1999) ruled out the different diapause responses arising from a single genotype. It therefore seems year to year differences in favourable seasonal variation is too small to select for risk-spreading (bet-hedging). In Zambia the onset of harsh conditions is likely to be predicted from environmental cues (Madder, 1999). Natural selection might therefore be acting on the individual responsiveness to these cues (so called environmental-conditional phenotype). Further studies to establish the actual situation in eastern province are needed.

Furthermore, if *R. appendiculatus* stocks from Eastern province originated from east Africa, they are likely to be later arrivals (compared to southern province ticks) in Zambia. Their “arrival” could have been round about the first reported case of ECF in Nakonde in 1922 (Nambota *et al.*, 1994). This supposition might explain the near absence of this tick on the eastern plateau in the report of MacLeod and

Mwanaumo (1978). According to these authors, it was in spite of the high cattle density in the area. Indeed, this points to a population struggling to establish itself in an area with a climate (single rainy season) not exactly suitable to its life cycle trait (absence of diapause phenotype in a large proportion of individuals). MacLeod and Mwanaumo (1978) did observe another anomalous *R. appendiculatus* infestation pattern; the high frequency of occurrence of *R. appendiculatus* in the Luangwa valley on wild animals just adjacent to the eastern plateau where none was collected (except at Chipata and Lundazi). Chipata and Lundazi may have been holding areas of the animals imported from east Africa through Mozambique (Dolan, 1999). The Luangwa valley specimens reported by MacLeod and Mwanaumo (1978) might have been Southern province like ticks that undergo an obligate diapause that might have since spread to Nyimba, a district bordering the valley.

To the contrary, Southern province *R. appendiculatus* like other *R. appendiculatus* stocks from the southern Africa ecological group may have been present since before the first case of ECF in southern Africa at the beginning of last century (Koch, 1903, quoted by Norval *et al.*, 1991; Dolan, 1999). Indeed, Theiler (1904) quoted in Norval *et al.* (1991) did categorically state that *R. appendiculatus* had been present in southern Africa before the appearance of ECF. Unlike on the Eastern province plateau, MacLeod (1970) describes the frequency of infestation of *R. appendiculatus* in the Southern province as “dominating” which could be an indication of a well established population. The single haplotype of the mitochondrial COI (and mt12SrDNA results not shown) of this tick observed in all our southern Africa specimens might point the long establishment and adaptation in southern Africa.

Lastly these results might be used as further evidence for historical geographical isolation between *R. appendiculatus* stocks from Southern province and those from Eastern province (see section 11.4). When and how this isolation took place cannot be determined with the current data.

### **11.5 Intraspecific genetic variation in *R. zambeziensis* from Southern province**

No study has yet compared genetic variation within *R. zambeziensis*. A study of genetic differentiation among *R. zambeziensis* stocks throughout the range of the species in Africa using phylogenetic methods to assess their relationships could provide important insights in the history of the species.



Sequences of mitochondrial 12S rDNA of field stocks of *R. zambeziensis* from Zambia were analysed together with those of specimens from South Africa as reference specimens. The Mitochondrial 12S rDNA haplotypes of stocks from different ecological regions in Zambia did not show any regional patterning. To the contrary their distribution was haphazard. The number of haplotypes was higher than those of the closely related *R. appendiculatus* sampled from the same area at the same time. We attributed this feature to high variance in reproductive success in this species between different seasons (Awise, 2000b; Madder *et al.*, 2005).

Speybroeck *et al.* (2002), using morphological identification methods did not find *R. zambeziensis* in the Livingstone area. Unlike these authors we found *R. zambeziensis* in the Livingstone area. The Livingstone area is in a typical *R. zambeziensis* region, but its microclimate is modulated by the mist of the Victoria Falls leading to increased humidity. This makes the area unsuitable for this species while surrounded by areas suitable for *R. zambeziensis*. In fact, across the falls on the Zimbabwean side, the area is a pure *R. zambeziensis* area (Norval *et al.*, 1982). This is because the main trade winds in the cool dry season are dry south easterlies, blowing the Victoria Falls moisture to the Zambian side leaving the Zimbabwe side drier and thus suitable for the species. However, it is possible that, in years of low rainfall, hence reduced mist from the Victoria Falls and consequently low humidity, *R. zambeziensis* might be sourced through host movement from the surrounding *R. zambeziensis* suitable areas into the Livingstone area, creating some temporary sink populations (Awise, 2000b).

Haplotypes of mitochondrial 12S rDNA for field stocks of *R. zambeziensis* from Zambia and South Africa were different. However, they were not sufficiently differentiated to warrant separate clusters on phylogenetic analysis. Therefore morphological differences exhibited by these stocks may be due to climatic and other local environmental factors.

### **11.6 Phylogenetic relationships of the different *R. appendiculatus*/*R. zambeziensis* stocks from Zambia**

Following investigation of intra and interspecific genetic and phenotypic variation in and between *R. appendiculatus* and *R. zambeziensis* it was important to assess how the different genetic and phenotypic groups represent monophyletic units under the phylogenetic species concept. Firstly, because the species status of *R. appendiculatus*

and *R. zambeziensis* has recently been questioned (Seybroeck *et al.*, 2002; Madder *et al.*, 2005) and secondly because some intraspecific variation observed in *R. appendiculatus* seemed to suggest difference species. Molecular phylogenetic methods have been used to both clarify species relationships (Zahler *et al.*, 1995; Zahler *et al.*, 1997; Gotoh *et al.*, 1998) and identify species (Ehara and Gotoh, 1996; Anderson and Trueman, 2000). To achieve this we sequenced the ITS2 (refer section 2.6.5.1) of *R. zambeziensis* and *R. appendiculatus* from areas with the different ecological, morphological and behaviour groups (Berkvens *et al.*, 1998; Chaka *et al.*, 1999; Speybroeck *et al.*, 2002). The ITS2 has been used to investigate species relations because it has been found to be quite conserved within species and exhibits substantial variation between species (Barker, 1998). The mitochondrial 12SrDNA on the other hand has been found to be good for investigations of relationships at the infraspecies level (Cruickshank, 2002). Analysis of the two sequences showed that *R. appendiculatus* represented a monophyletic unit and so did *R. zambeziensis*. Specimens identified as morphologically intermediates were found in both the *R. zambeziensis* and *R. appendiculatus* groups. The two monophyletic groups were robustly supported (fig.8.1). As such they represented to separate species in the phylogenetic species context. Therefore *R. appendiculatus* and *R. zambeziensis* are not mere morphological variants (ecomorphs). The two species may be in divergence i.e. they might have come out of a speciation event “recently” and their ranges are not yet isolated and isolation mechanisms between them are not complete. They could be in convergence i.e. they underwent a speciation event and after some time their ranges have overlapped again (Zivkovic *et al.*, 1986). The fate of their encounter is likely to be determined by the extent of the isolation mechanisms acquired and their degree of ecological compatibility.

There is partial evidence of hybridization of the two in the wild (Berkvens, 2002). This evidence if validated would still not affect our conclusions, because species as determined by the PSC may interbreed.

The *R. appendiculatus* monophyletic unit was an unresolved assemblage in which *R. appendiculatus* from Eastern province forms a monophyletic group. This provides strong evidence for the geographic genetic differentiation discussed in section (11.3)

Speciation may have been due to expansion and contraction of *R. appendiculatus* at the periphery and within its favourable range into ecologically unfavourable areas in

alternating favourable and unfavourable climatic conditions. Indeed the range of *R. appendiculatus* is dynamic, expanding and contracting depending on climatic conditions (Berkvens *et al.*, 1998, Norval *et al.*, 1992). This contraction or expansion of the range might have resulted in isolation of small subpopulations in ecologically unfavourable areas within the range of the species distribution. The small size of these subpopulations could have enhanced the rate of speciation since as a rule speciation is faster in smaller populations (see peripatric speciation in 2.5.3). The barriers to gene flow in this case could have been ecological and physiographic barriers. It is apparent from the above that more than one model of speciation has been invoked to explain possible speciation of the species. Indeed speciation models are not either or alternatives, but can be a combination of many, though they need not necessarily coincide (Mayr, 1982).

### **11.7 Comparison of preserved *R. appendiculatus* material for quality of DNA isolated for use in PCR techniques**

After assessing the relationships of the different groups in the *R. appendiculatus* / *R. zambeziensis*, it was apparent that a tool was needed for the correct identification of the members. This was imperative because the two different species and groups within *R. appendiculatus* bring different influences to the epidemiology of ECF. However, a tool for the identification of *R. appendiculatus* and *R. zambeziensis* was already developed in the form of GPI (EC 5.3.1.9) isoenzyme zymograms (Wouters, *et al.*, 1987). A major disadvantage of enzyme electrophoresis based methods is that the technique requires fresh (sacrificed immediately before laboratory procedure) or frozen biological materials (Navajas and Fenton, 2000). Fresh specimens are not always available. This is true in cases where variation is to be studied over a long period of time and or over a large geographical area. Maintenance of the cold chain cannot be guaranteed in the context of studying variation in resource poor nations. This therefore rules out cryopreservation as a practical preservation method in such contexts, limiting the practicality of GPI electrophoresis. Therefore this part of the work was undertaken to compare how methods, other than cryopreservation, of *R. appendiculatus* material would fare in purification of DNA for use in PCR based techniques.

Ticks preserved as dried, cryopreserved, refrigerated, in 70% ethanol and fresh ticks were compared for the quality of DNA extracted from them based on the ability of such DNA to be amplified in PCR.

The results of this study showed that fresh tick materials are always superior for DNA isolation to any preserved material. It was further shown that preservation in 70% alcohol was just as good as cryopreservation.

While cryopreservation is the next best thing to having fresh tick materials (Cruickshank, 2000) and cryopreserved materials are useful for both DNA and for enzyme isolation there are, however, a number of problems with this preservation method. Firstly the success of isolation of DNA or Isoenzyme in some species depends on the killing process of the cryopreserved materials (Dean *et al.*, 2001). Ticks collected off cattle are likely to be stressed from wounds on the mouth parts as they are pulled off the host. We observed reduced success of amplification in cryopreserved specimens that were weak (low activity) at point of being killed in Liquid nitrogen (unpublished observation). It is possible that such ticks accumulated stress factors after some time due to the sheer termination of their feeding process and the changed environment e.g. ambient temperature. Indeed it has been observed that the physiological state of an organism before being killed may affect DNA yield (Rey *et al.*, 2004). Such stress may be avoided by killing the specimens at point of collection. This entails travelling with liquid nitrogen canisters during collection missions, a cumbersome feat. Maintenance of specimens in liquid nitrogen is expensive as it requires regular top up. If materials are eventually preserved in an ultra-freezer, power cuts may compromise the quality of materials by the freeze and thaw cycles. Continuous supply of power cannot be guaranteed in Zambia and in many so called resource poor nations. Thirdly and finally cryopreserved materials are very delicate and are therefore not easily amenable to a lot of manipulations after removal from the refrigerator. Any manipulations must be done on ice as thawing results in break down of DNA by endonucleases (Dean and Ballad, 2001).

With all the disadvantages, in the context of our study, of cryopreservation referred to above it is very significant that alcohol preservation of tick materials is as good as cryopreservation. The advantage of this is that ticks can be killed immediately in alcohol in specimen bottles at point of collection (before they accumulate stress factors or are about to die) since alcohol, unlike liquid nitrogen, does not require

sophisticated receptacles for its storage, but simple sealed sample bottles. Sealed sample bottles containing alcohol do not need topping up thus making it a relatively cheaper storage mode. Tick materials stored in alcohol need not necessarily be kept in a refrigerator. Therefore, there is no risk of compromising the samples due to failure of the cold chain. Tick samples that have been stored in alcohol can be manipulated in the absence of ice without fear of compromising their quality for DNA isolation.

Drying was found to be the least successful mode of preservation. This was in agreement with the observation of Cruickshank (2000). Finally PCR based methods are known to utilise small quantities of the biological materials for DNA extraction and amplification. We showed that tick legs could be used in DNA isolation just like in mosquitoes. The non-destruction of the whole specimen is important for later clarifications of identification as the source specimen of the DNA would still be available with taxonomically important morphological parts undisturbed. The technique for isolating DNA from legs of preserved tick specimens, however, will need to be improved upon to obtain higher success.

### **11.8 Development of PCR-RFLP tool for the discrimination of *R. appendiculatus* and *R. zambeziensis***

The current methods in use for identification of *R. appendiculatus* and *R. zambeziensis* either lack discriminatory power (morphology and diapause demonstration) (Walker *et al.*, 1981; Berkvens *et al.*, 1995; Madder and Berkvens, 1997) or are not compatible with different preservation processes (Isoenzyme electrophoresis) (Navajas and Fenton, 2000) or are just practically cumbersome (demonstration of diapause) (Madder and Berkvens, 1997). Morphological identification is naturally the most commonly used and the first step in correct species identification. Unfortunately, it is impossible at the morphological level to correctly allocate every specimen of *R. appendiculatus* and *R. zambeziensis* collected in southern Zambia to their correct nominal taxa due to close morphological similarities compounded by morphologically intermediate specimens. This difficulty in morphological identification creates problems and confusions in understanding the epidemiology and consequently control of ECF. An example of such confusion was reported by Mulumba *et al.* (2000, 2001). This observation was unusual in two ways. Firstly, the occurrence of ECF out breaks in southern Zambia corresponds to the period of peak adult tick activity. Only one peak adult activity has been documented

in Southern province. This meant nymphal activity was responsible for the cool dry season outbreaks. Therefore the second problem was why would the length of the rainy season vary the efficiency of larval to nymph transmission? Because, evidence from several studies is that nymph to adult transmission is more efficient (Ochanda *et al.*, 1996; Tempia, 1997) probably due to failure of larvae to pick up infection when fed on cattle with low parasitaemia (Tempia, 1997; Marcotty *et al.*, 2002) and the low number of acini available for *T. parva* during the initial moults (Walker, 1990). This epidemiological puzzle was investigated further by comparing *T. parva* infections in the ticks collected from the area during the season with below average rainfall and those collected from an area with pure *R. appendiculatus*. The results of laboratory infected tick dissections showed 20 times higher infection rates in nymphs of ticks collected during the dry years than in those collected during the wet year (Mulumba, 1999). The epidemiological puzzle unfolded further when the ticks collected during dry years were characterized as *R. zambeziensis* (Madder *et al.*, 2005).

It can be seen from the foregoing that availability of a high resolution tool for correctly identifying both species so as to have accurate estimates of their proportions, their phenologies and distribution and hence ascertain their role in the epidemiology of ECF is very important. Correct identification sets the stage for the devising appropriate vector/disease monitoring and intervention measures.

In recognition of the foregoing a high resolution PCR-RFLP tool based on the digestion of the ITS2 amplicon by a single restriction endonuclease *Bacillus aquaemaris* RFL1 (Baul) was developed to identify *R. appendiculatus* and *R. zambeziensis*. It was our intention to find a restriction endonuclease that would digest the ITS2 into fragments big enough to be resolved on agarose gel. Agarose gels are simpler and faster to run. The ITS2 amplicons of *R. appendiculatus* from Zambia, South Africa, Rwanda and the Comore were digested. Other ITS2 amplicons included those of *R. zambeziensis* and *Rhipicephalus evertsi evertsi* and *R. turanicus* the two species that were used as outgroup species in the assessment of the relatedness of the two species (*R. appendiculatus* and *R. zambeziensis*) in phylogenetic analysis (section 8.2.6). In all these, the ITS2 restriction profiles for *R. appendiculatus* and *R. zambeziensis* after resolution of the fragments in agarose gel were the same within each species and could be differentiated from each other and from those of *R.e. evertsi* and *R. turanicus*.

We recognize that PCR equipment may not be available in every laboratory especially in resource poor countries like Zambia. Since *BauI* PCR-RFLP tool is not for disease (ECF) diagnosis, it need not be invoked frequently. To the contrary it is a tool for determination of *R. appendiculatus* and *R. zambeziensis* patterns and therefore a planning tool in the control of ECF.

With this tool in our quiver, we suggest a revisit of the phenology of *R. zambeziensis* in Zambia. Since diapause in adults of *R. zambeziensis* has not been demonstrated its phenology might be slightly different from that of *R. appendiculatus*. Indeed, according to Madder (pers.comm) Horak has observed a slightly delayed peaking of adults of *R. zambeziensis* in South Africa compared to those of *R. appendiculatus*. In addition, a combination of improved sampling and application of this tool may be useful in further investigations of the presence or otherwise of *R. zambeziensis* from the Eastern province of Zambia where it is yet to be demonstrated undisputedly (Berkvens *et al.*, 1998).

Finally, the authors emphasize that despite the high resolution of the molecular tool, molecular identification methods cannot replace but rather are a complement to morphological identification methods which still remain the first step in correct species identification.

### **11.9 Preliminary search for *R. zambeziensis* in Eastern province using the *BauI* PCR-RFLP tool**

The presence of *R. zambeziensis* in Eastern province of Zambia has been disputed (Norval *et al.*, 1982; Berkvens *et al.*, 1998). The results of our application of the *BauI* PCR-RFLP on samples from Nyimba, Petauke and Chipata all in the Eastern province did not yield any *R. zambeziensis* like profiles in all the three hundred samples tested. This shows how rare this species is in the districts we sampled if it is there at all. However, its absence cannot be ascertained from the current data until better sampling including areas where this species was at one time reported like Chipangali (13°10'S., 32°46'E) (Norval *et al.*, 1982) and Luangwa valley (MacLeod and Mwanaumo, 1978) are included.

### **11.10 Conclusions and future prospects**

The results of our studies have contributed to an improved understanding of the variation found in *R. appendiculatus* and *R. zambeziensis* by revealing the source of

the variation and its nature in this tick vector complex. The development of an identification tool for *R. appendiculatus* and *R. zambeziensis* of higher resolution and wider practical use that may be used in studies to further understand this diversity is significant too. The significance and implications of the findings have been discussed under individual sections. These may now be condensed under two heads of tick ecology and evolution, and epidemiology.

### **11.10.1 Tick ecology and evolution**

We conclude from our studies that ecological differences observed in collections of *R. appendiculatus* from Zambia arise from a source that is both inter and intra-specific. Inter-specific variation is due to the mixed presence of the two species *R. appendiculatus* and *R. zambeziensis*. These are two separate phylogenetic species whose ranges may be diverging or converging. We further conclude that going by the situation in Zambia it might be impossible to morphologically place every specimen of *R. appendiculatus* or *R. zambeziensis* according to their nominal taxa. This difficulty arises particularly due to the presence of morphological intermediates whose real species status is not always one of the two species. Consequently, a PCR-RFLP tool has been developed to differentiate between the two species. This will be helpful in studying the ecology of especially *R. zambeziensis* in Zambia for which various aspects of the ecology tend to be generally lumped with that of *R. appendiculatus*. It will be useful too for studying the continually changing ecology (like happens in any species) of *R. appendiculatus*

Intra-specific variation arises from the geographic genetic differentiation of populations of *R. appendiculatus* from the Southern and Eastern provinces. We surmise that the genetic differentiation of the two *R. appendiculatus* populations might be due to historical geographic isolation and possibly current behavioural differences. We further infer that Eastern province stocks might be recent arrivals into Zambia that must have arrived about the time (early to mid 20<sup>th</sup> century) of the first reported cases of ECF in Eastern and Northern provinces of Zambia from east Africa while the Southern province stocks are an extension of the southern African stocks that had been present well before the first ECF cases. It might be for that reason that the latter seem to be well adapted to the single short rainy season of southern Africa through delayed feeding by diapause in order to synchronize oviposition with the availability of favourable climatic conditions. The former have a mixed diapause



response phenotype possibly arising from different genotypes in an area with a longer and variable, yet unimodal rainy season than the southern province compared to multimodal rain pattern of its putative area of origin. As a result we suggest that expression of diapause phenotype in this population might not be plastic. We are also inclined to think that the variable expression of diapause in these ticks is not a bet-hedging (risk-spreading) tactic, precisely because we think the variation in the length of the rainy season in eastern province might be too small to select for risk-spreading. We therefore suggest that the most likely mode of selection is on the ability to decipher environmental cues responsible for prediction of harsh conditions. We recommend that the ranges of the Southern and Eastern province populations be delimited and the biology and ecology of their progeny explored.

In addition we conclude that *Rhipicephalus zambeziensis* stocks from Zambia are not ecologically genetically differentiated despite variation in their morphology. The phenotypic differences are plastic variations due to differences in climatic and other local conditions. We attributed variability of 12S rDNA haplotypes in *R. zambeziensis* despite high host movement in the sampling area to the high variance in reproductive success in this species.

### **11.10.2 Epidemiology**

Difficult as it may be to morphologically differentiate *R. appendiculatus* and *R. zambeziensis*, the two are different species with different vector competences and other ecological differences (e.g. development periods) that are associated with marked differences in the epidemiology of ECF. We surmise that the presence of *R. zambeziensis* in Southern province helps in the maintenance of the current epidemiological epidemic state which might otherwise been close to epidemic unstable. The development of the PCR-RFLP tool is therefore important assessing the “contribution” of either vector to the epidemiological situation of ECF as climatic conditions vary, since the two species vary differently with fluctuating lengths in the rainy season. We have called the Eastern province and Southern province stocks of *R. appendiculatus* epidemiologically different management units (EMUs). This is to stress that despite these stocks being in the same *R. appendiculatus* as the ticks from Southern province they should be managed differently in as far as ECF control is concerned. Indeed the epidemiology of ECF in each stock’s area of endemicity is different and both stocks show differential susceptibility to the dominant circulating

*T. parva* strains in the other's area of endemicity. This has been rightly attributed to different geographical origin of parasite and vector, but we suggest might also include an inherent difference in vector competences. Stringent tick control should therefore be practised when moving hosts between different areas.

Therefore, with further improvements in the knowledge of diversity of the vectors and availability of a tool for their identification, better monitoring of the changing ecology of the tick and the epidemiology of ECF can be made.

### **11.11 Future research**

The following areas will need further investigations

- For ecological and evolutionary expedience it will be important to investigate the mechanisms *R. zambeziensis* uses to survive adverse environmental conditions in the hot valleys since it is not known to undergo diapause.
- With improved sampling a further search for *R. zambeziensis* should be undertaken in the eastern province including areas where it was previously reported.
- The current limits of the ranges of the two genetic groupings of *R. appendiculatus* should be determined both within and outside Zambia.
- Studying the biology of the progeny of these two geographically genetically differentiated stocks might be helpful in the prediction of the epidemiology of ECF in the likely event of their ranges overlapping.
- From the evidence of the COI and the combined evidence of the ITS2 12SrDNA there is partial support for two subgroups within the Eastern province *R. appendiculatus* group. It would be interesting to determine whether these groups correspond to the two different ecological groups of adults that are observed in Eastern province.

## 11.12 References

- Anderson, D.L. and J.W.H. Trueman. 2000. *Varroa jacobsoni* (Acari: Varroidae) is more than one species. *Experimental and Applied Acarology*, 24, 165–189.
- Avise, J.C. 2000a. Chapter 5 (pp215-284). Genealogical concordance. *In: Phylogeography: The history and formation of species*, pp 447. Harvard University Press, Cambridge and London.
- Avise, J.C. 2000b. Chapter 2 (pp37-108). Demography-Phylogeny connections. *In: Phylogeography: The history and formation of species*, pp 447. Harvard University Press, Cambridge and London.
- Barker, S.C. 1998. Distinguishing species and populations of Rhipicephaline ticks with ITS 2 ribosomal RNA. *Journal of Parasitology*, 84, 887-892.
- Berkvens, D.L., D.M. Geysen and G.M. Lynen. 1989. East Coast Fever immunisation in the Eastern Province of Zambia (pp83-86). *In: Dolan, T.T. (Eds.). Theileriosis in Eastern, Central and Southern Africa*. International Laboratory for Research on Animal disease, Nairobi.
- Berkvens, D.L., R.G. Pegram and J.R.A. Brandt. 1995. A study of the diapausing behaviour of *Rhipicephalus appendiculatus* and *R. zambeziensis* under quasi-natural conditions in Zambia. *Medical and Veterinary Entomology*, 9, 307-315.
- Berkvens, D.L., D.M. Geysen, G. Chaka, M. Madder and J.R.A. Brandt 1998. A study of ixodid ticks parasitizing cattle in the Eastern Province of Zambia. *Medical and Veterinary Entomology*. 12, 234-240.
- Berkvens, N. 2002. Differentiatie van teken van het *Rhipicephalus appendiculatus/R. zambeziensis* complex uit Zambia. Scriptie voorgedragen tot het behalen van de graad van Bio-ingenieur in de Landbouw. Ghent University.
- Billiow, M., L. Mataa, T. Marcotty, G. Chaka, J. Brandt and D. Berkvens. 1999. The current epidemiological status of bovine theileriosis in eastern Zambia. *Tropical Medicine and International Health*, 4, A28-A33.
- Billow, M. 2005. Analysis of the transmission dynamics of *Theileria parva* (pp85-105). *In: The epidemiology of bovine theileriosis in the Eastern province of Zambia*. PhD thesis.
- Billiow, M., J. Vercruysse, T. Marcotty, N. Speybroeck, G. Chaka and D. Berkvens. 2002. *Theileria parva* epidemics: a case study in eastern Zambia. *Veterinary Parasitology*, 107, 51-56.
- Chaka, G., M. Billiow, D.M. Geysen and D.L. Berkvens 1999. Spatial and temporal variation in *Rhipicephalus appendiculatus* size in eastern Zambia. *Tropical Medicine and International Health*, 4, A43-A48.
- Cruickshank, R.H. 2002. Molecular markers for the phylogenetics of mites and ticks. *Systematic and Applied Acarology*, 7, 3-14.
- De la Fuente, J. and K.M. Kocan. 2003. Advances in the identification and characterization of protective antigens for recombinant vaccines against tick infestations. *Expert Review of Vaccines*, 2, 583-593.

- De la Fuente, J., C. Almazán, R. A. Van Den Bussche, J. Bowman, J. H. Yoshioka and K. M. Kocan. 2005. Characterization of genetic diversity in *Dermacentor andersoni* (Acari: Ixodidae) with body size and weight polymorphism. *Experimental Parasitology*, 109, 16-26.
- Dean, M. D. and J.W.O. Ballad. 2001. Factors affecting DNA quality from museum preserved *Drosophila simulans*. *Entomologia Experimentalis et Applicata*, 98, 279–283.
- Dolan, T.T. 1999. Dogmas and misunderstandings in East Coast fever. *Tropical Medicine and International Health*, 4, PP A3-A11.
- Ehara, S. and T. Gotoh. 1996. Two new species of spider mites occurring in Japan (Acari; Tetranychidae). *Journal of Acarological Society of Japan*, 5, 17–25.
- Esperk, T. and T. Tammaru. 2004. Does the ‘investment principle’ model explain moulting strategies in lepidopteran larvae? *Physiological Entomology*, 29, 56-66.
- Fandamu, P., L. Duchateau, N. Seybroeck, T. Marcotty, V. Mbaio, J. Mtambo, M. Mulumba and D. Berkvens. 2005a. *Theileria parva* seroprevalence in traditionally kept cattle in southern Zambia and El Niño. *International Journal for Parasitology*, 35, 391-396.
- Fandamu, P., L. Duchateau, N. Speybroeck, M. Mulumba and D. Berkvens. 2005b. East Coast fever and Multiple El Niño Southern Oscillation Ranks. *Veterinary Parasitology*, 135, 147-152.
- Fivaz, B.H. and A. Norval. 1989. Observations on successive infestations of the rabbit host by the ticks *Rhipicephalus appendiculatus* and *R. zambeziensis* (Acari: Ixodidae). *Experimental and Applied Acarology*, 7, 267-269.
- Geysen, D., R. Bishop, R. Skilton, T.T. Dolan and S. Morzaria. 1999. Molecular epidemiology of *Theileria parva* in the field. *Tropical Medicine and International Health*, 4, A21-A27.
- Gleiser, R.M., J. Urrutia and D.E. Gorla. 2000. Body size variation in the floodwater mosquito *Aedes albifasciatus* in Central Argentina. *Medical and Veterinary Entomology*, 14, 38-43.
- Gooding, R.H. 1996. Genetic variation in arthropod vectors of disease-causing organisms: obstacles and opportunities. *Clinical Microbiology Reviews*, 9, 301-320.
- Gotoh, T., J. Gutierrez and M. Navajas. 1998. Molecular comparison of the sibling species *Tetranychus pueraricola* Ehara & Gotoh and *T. urticae* Koch (Acari: Tetranychidae). *Entomological Science*, 1, 55–57.
- Hernandez, R., A.C. Chen, R.B. Davey, G.W. Ivie, G.G. Wagner and J.E George. 1998. Comparison of genomic DNA in various strains of *Boophilus microplus* (Acari: Ixodidae). *Journal of Medical Entomology*, 35, 895–900.
- Hopper, K.R. 1999. Risk-spreading and bet-hedging in insect population biology. *Annual Review of Entomology*, 44, 535-560.
- Irvin, A.D., S.P. Morzaria, F.C. Munatswa and R.A.I. Norval. 1989. Immunization of cattle with *Theileria parva bovis* stock from Zimbabwe protects against

- challenge with virulent *T.p. parva* and *T.p. lawrencei* stocks from Kenya. *Veterinary Parasitology*, 32, 271-278.
- Kaba, S.A., A. Musoke, D. Schaap, T. Schettters, J. Rowlands, A.N. Vermuelen, V. Nene, J.M. Vlak and M.M van Oers. 2005. Novel baculovirus-derived p67 subunit vaccines efficacious against East Coast fever in cattle. *Vaccine*, 23, 2791-2800.
- Kivaria, F.M., M.R. Ruheta, P.A. Mkonyi and P.C. Malamsha. 2007. Epidemiological aspects and economic impact of bovine theileriosis (East Coast fever) and its control: A preliminary assessment with special reference to Kibaha district, Tanzania. *The Veterinary Journal*, 173, 384-390.
- Le Goff, G., J.-M. Léong, Pock Tsy and V. Robert. 2006. Molecular characterization of the malaria vector *Anopheles gambiae* s.s. in Madagascar. *Medical and Veterinary Entomology*, 20, 259-260.
- Lewontin, R.C. 1974. *The Genetic Basis of Evolutionary Change*. Columbia University Press, New York and London.
- MacLeod, J. 1970. Tick infestation in the southern province of Zambia. *Bulletin of Entomological Research*, 60, 253-274.
- MacLeod, J. and B. Mwanuemo. 1978. Ecological studies of ixodid ticks (Acari, Ixodidae) in Zambia IV. Some anomalous infestations in the northern and eastern regions. *Bulletin of Entomological Research*, 68, 409-429.
- Madder, M. and D. Berkvens. 1997. Evaluation of an *in vitro* method to measure behavioural diapause in the tick *Rhipicephalus appendiculatus* (Acarina, Ixodidae) in the laboratory. *Parasitology*, 155, 97-100.
- Madder, M. 1999. General Discussion (pp109-123). *In: Behavioural diapause in Rhipicephalus appendiculatus* Neumann (Acari, Ixodidae). PhD Thesis ,pp147. Ghent University, Belgium.
- Madder, M., N. Speybroeck, J. Brandt, L. Tirry, I. Hodek and D. Berkvens. 2002. Geographic variation in diapause response of adult *Rhipicephalus appendiculatus* ticks. *Experimental and Applied Acarology*, 27, 209-221.
- Madder, M., N. Speybroeck, A. Bilounga, D. Helleputte and D. Berkvens. 2005. Survival of unfed *Rhipicephalus appendiculatus* and *Rhipicephalus zambeziensis* adults. *Medical and Veterinary Entomology*, 19, 245-250.
- Marcotty, T., J. Brandt, M. Billiouw, G. Chaka, B. Losson and D. Berkvens. 2002. Immunisation against *Theileria parva* in eastern Zambia: influence of maternal antibodies and demonstration of carrier status. *Veterinary Parasitology*, 110, 45-56.
- Mayr, E. 1982. Mechanisms of speciation (pp1-19); proceedings from the International Meeting on Mechanisms of speciation. *In: Barigozzi, C (Eds.) Progress in clinical and Biological Research Vol 96*. Alan R. Liss inc. New York.
- Mcmichael, M. and H.G. Hall. 1996. DNA RFLPs at a highly polymorphic locus distinguish European and African subspecies of the honey bee *Apis mellifera*

- L. and suggest geographical origins of the New World honey bees. *Molecular Ecology*, 5, 403-416.
- Mulumba, M. 1999. Epidemiology of *Theileria parva* Theileriosis in Southern province of Zambia. PhD thesis, ITMA, Belgium.
- Mulumba, M., N. Speybroeck, M. Billiouw, D.L. Berkvens, D.M. Geysen and J.R. Brandt. 2000. Transmission of *Theileria parva* in the traditional farming sector in the Southern province of Zambia during 1995-96. *Tropical Animal Health and Production*, 32, 303-314.
- Mulumba, M., N. Speybroeck, D.L. Berkvens, D.M. Geysen and J.R. Brandt. 2001. Transmission of *Theileria parva* in the traditional farming sector in the Southern province of Zambia during 1997-98. *Tropical Animal Health and Production*, 33, 117-125.
- Musoke, A., J. Rowlands, V. Nene, J. Nyanjui, J.M. Katende, P.R. Spooner, S.N. Mwaura, D. Odongo, C. Nkonge, S. Mbongo, R. Bishop and S. Morzaria 2005. Subunit vaccine based on the p67 major surface protein of *Theileria parva* sporozoites reduces severity of infection derived from field tick challenge. *Vaccine*, 23, 3084-3095.
- Nambota, A., K. Samui, C. Sugimoto, T. Kakuda and M. Onuma. 1994. Theileriosis in Zambia: etiology, epidemiology, and control measures. *Japanese Journal of Veterinary Research*, 42, 1-18.
- Nambota, A.M., C.E.A. Lovelace, H. Chitambo, T. Kakuda, C. Sugimoto and M. Onuma. 1997. Characterization of some *Theileria parva* stocks from Zambia using monoclonal antibodies. *Journal of Veterinary Medical Science*, 59, 1-4.
- Navajas, M. and B. Fenton. 2000. The application of molecular markers in the study of diversity in acarology: a review. *Experimental and Applied Acarology*, 24, 751-774.
- Neargarder, G., E.P. Dahlhoff and N.E. Rank. 2003. Variation in thermal tolerance is linked to phosphoglucose isomerase genotype in a montane leaf beetle. *Functional Ecology*, 17, 213-221.
- Norval, R.A.I., J.B. Walker and J. Colborne. 1982. The ecology of *Rhipicephalus zambeziensis* and *Rhipicephalus appendiculatus* (Acarina, Ixodidae) with particular reference to Zimbabwe. *Onderstepoort Journal of Veterinary Research*, 49, 181-190.
- Norval, R.A.I., J.A. Lawrence, A.S. Young, B.D. Perry, T.T. Dolan and J. Scott. 1991. *Theileria parva*: influence of vector, parasite and host relationships on the epidemiology of theileriosis in southern Africa. *Parasitology*, 102, 347-356.
- Norval, R.A.I., B.D. Perry, A.S. Young. 1992. The epidemiology of theileriosis in Africa pp 481. Academic Press, London.
- Ochanda, H., A.S. Young, C. Wells, G.F. Medley and B.D. Perry. 1996. Comparison of transmission of *Theileria parva* between different instars of *Rhipicephalus appendiculatus*. *Parasitology*, 113, 243-253.

- Ochanda, H., A.S. Young, G.F. Medley and B.D. Perry. 1998. Vector competence of 7 rhipicephalid tick stocks in transmitting 2 *Theileria parva* parasite stocks from Kenya and Zimbabwe. *Parasitology*, 116, 539-545.
- Ovenden, J.R. 1990. Mitochondrial DNA and marine stock assessment: a review. *Australian Journal of Marine Freshwater Research*, 41, 835-853.
- Pascual, M., J. Balanya, A. La Torre and L. Serra. 1997. Diagnosis of the sibling species of *Drosophila* involved in the colonization of North America by *D. subobscura*. *Molecular Ecology*, 6, 293-296.
- Pegram, R.G., B.D. Perry, F.L. Musisi and B. Mwanaumo. 1986. Ecology and phenology of ticks in Zambia: seasonal dynamics on cattle. *Experimental and Applied Acarology*, 2, 25-45.
- Perrin, A., C. Cetre-Sossah, B. Mathieu, T. Baldet, J.-C. Delecolle and E. Albina. 2006. Phylogenetic analysis of *Culicoides* species from France based on nuclear ITS1-rDNA sequences. *Medical and Veterinary Entomology*, 20, 219-228.
- Rey, I., B.A. Dorda and A.G. Valdecasas. 2004. Traditional water mite fixatives and their compatibility with later DNA studies. *Experimental and Applied Acarology*, 34, 59-65.
- Ridley, M. 2004. *Evolution* (3<sup>rd</sup> Edition). Blackwell Publishing, Oxford, UK.
- Seger, J. and H.J. Brockman. 1987. What is bet-hedging? *Oxford Surveys in Evolutionary Biology*, 4, 182-211.
- Speybroeck, N., M. Madder, P. Van Den Bossche, J. Mtambo, N. Berkvens, G. Chaka, M. Mulumba, J. Brandt, L. Tirry and D. Berkvens. 2002. Distribution and phenology of ixodid ticks in southern Zambia. *Medical and Veterinary Entomology*, 16, 430-441.
- Speybroeck, N., M. Madder, H.H. Thulke, J. Mtambo, L. Tirry G. Chaka, T. Marcotty and D. Berkvens. 2004. Variation in body size in the tick complex *Rhipicephalus appendiculatus/Rhipicephalus zambeziensis*. *Journal of Vector Ecology*, 29, 347-354.
- Sokal, R. R. 1994. The continuing search for order (pp235-256). *In: Sober, E (ed). Conceptual issues in evolutionary biology*. MIT Press, Cambridge, Massachusetts.
- Tempia, S. 1997. Comparison of the vectorial capacity of *Rhipicephalus appendiculatus* (Acari: Ixodidae) nymphs and adults originating from Eastern and Southern provinces of Zambia infected by *Theileria parva* Katete stock. ITMA MSc Thesis No.65.
- Trimnell, A. R., R.S. Hails and P.A. Nuttall. 2002. Dual action ectoparasite vaccine targeting 'exposed' and 'concealed' antigens. *Vaccine*, 20, 3560-3568.
- Walker, A.R. 1990. Parasitic adaptation in the transmission of *Theileria* by ticks-a review. *Tropical Animal Health and Production*, 22, 23-33.
- Walker, A. R. 2007. Theileriosis and the tick control conundrum: a better way forward? *The Veterinary Journal*, 173, 248-249.
- Walker, J.B., R.A.I. Norval and M.D. Corwin. 1981. *Rhipicephalus zambeziensis* sp. nov., a new tick from eastern and southern Africa, together with a

- redescription of *Rhipicephalus appendiculatus* Neumann, 1901 (Acarina, Ixodidae). Onderstepoort Journal of Veterinary Research, 48, 87-104.
- Wouters, G., J. Brandt and D. Berkvens. 1987. Species characterization of *Rhipicephalus appendiculatus* and *Rhipicephalus zambeziensis* (Ixodidae: Acarina) by enzyme electrophoresis. Annales de la Société belge de médecine tropicale. 67, 267-270.
- Wouters, G. 1989. Hybridization model for *Rhipicephalus appendiculatus* and *R. zambeziensis* by glucose-p-isomerase isoenzymes. Onderstepoort Journal of Veterinary Research, 56, 235-238.
- Yeoman, G.H. and J.B. Walker. 1967. The Ixodid ticks of Tanzania. Commonwealth Institute of Entomology, London, pp215.
- Zahler, M., R. Gothe and H. Rinder. 1995. Genetic evidence against a morphologically suggestive conspecificity of *Dermacentor reticulatus* and *D. marginatus* (Acari: Ixodidae). International Journal of Parasitology, 25, 1413–1419.
- Zahler, M., N.A. Filippova, P.C. Morel, R. Gothe and H. Rinder. 1997. Relationships between species of the *Rhipicephalus sanguineus* group: a molecular approach. Journal of Parasitology, 83, 302–306.
- Zivkovic, D., R.G. Pegram, F. Jongejan and E.T. Mwase. 1986. The biology of *Rhipicephalus appendiculatus* and *R. zambeziensis* and production of a fertile hybrid under laboratory conditions. Experimental and Applied Acarology, 2, 285-298.



## **Chapter 12 - SUMMARY**

The first chapter presents the essentials of the species *Rhipicephalus appendiculatus* and *Rhipicephalus zambeziensis* that include their systematic relationships with other ticks, their life cycle and distribution in Africa in general and in Zambia in particular. The chapter further introduces *R. appendiculatus* and *R. zambeziensis* as vectors of *Theileria parva* the causative organism of East Coast fever in cattle. *Theileria parva* systematic relationships and life cycle are presented in this chapter and the economic importance of ECF is briefly stated. The chapter ends with a few facts about the Zambian climate and vegetation in as far as they affect the dynamics and distribution of *R. appendiculatus* and *R. zambeziensis* and the epidemiology of ECF. The different epidemiological states of ECF in the areas under study are stated which are attributed mainly to variation in the ecology of the vectors setting the stage for the second chapter. The initial part of chapter 2 introduces the whole concept of variation with emphasis on variation within species (intra-specific variation) and the puzzles it creates with respect to taxonomy and epidemiology. Dealing with taxonomical puzzles has led to a plethora of so called species concepts of which only, the morphological, biological, evolutionary, phylogenetic and ecological species concepts were reviewed. Species concepts inevitably have to grapple with speciation, the history of formation of species. Only geographic models of speciation deemed relevant to these studies were reviewed. The review then considered methods of reconstructing speciation. The review next outlined established facts, disagreements and gaps in the knowledge of variation within and between *R. appendiculatus* and *R. zambeziensis*. A range of phenotypes were considered, from the most visible like morphology and behaviour, to biochemical and microscopic characters. All the phenotypes considered have documented variation both within and between *R. appendiculatus* and *R. zambeziensis*. Variations in some phenotypes within *R. appendiculatus* were linked to the difference in epidemiology of ECF in eastern and southern Zambia. However, phenotypic variation between the two nominal taxa is not prominent resulting in the controversy of whether the two nominal taxa correspond to two good species. Finally the review considered genetic variation in *R. appendiculatus* and *R. zambeziensis* for which little information exists except that relating to the systematics of *R. appendiculatus* and *R. zambeziensis* at higher levels. The review concludes with a statement on the ubiquity of variation being found in gross morphology to the DNA of a species and the importance of linking genetic variation and the vectors' (*R. appendiculatus* and *R. zambeziensis*) important

phenotypes of vector competence, host preference, diapause, feeding behaviour and life cycle traits.

The objectives of this thesis are presented in chapter 3. To describe intra- and inter-population variation within and between *R. appendiculatus* and *R. zambeziensis* with the aim of improving our taxonomic understanding of this species complex and to assess how this variation may be affecting the epidemiology of East Coast fever. More specifically these studies were set to: 1) Describe phenotypic and genetic variation within and between *R. appendiculatus* and *R. zambeziensis* and use phylogenetic methods to assess how far both species and constituent stocks represent monophyletic units. 2) Compare methods of preserving tick material for DNA extraction for use in PCR techniques and, 3) to develop a molecular tool for the identification of *R. appendiculatus* and *R. zambeziensis*.

The fourth chapter presents the results of a study that compared the phenotypes (morphological and life cycle traits) of three stocks of ticks, two (Nkonkola and Keemba) from Southern and one (Wafa) from Eastern province. Morphological comparison was done in the presence of *R. appendiculatus* and *R. zambeziensis* from South Africa as control stocks. Results of morphological comparisons indicated a closer relationship between *R. appendiculatus* control stock and the Nkonkola - Southern province stock. This was also the case for the *R. zambeziensis* control stock and the Keemba-Southern province stock. The phenotypes of the Eastern province stock were by and large intermediate between the *R. appendiculatus* and *R. zambeziensis* clusters. Generally the three stocks from Zambia could be differentiated based on the morphological features considered. However, the differentiation might not be practical due to intermediate morphological forms. Besides, morphological variation in nature is likely to be greater due to varied rearing conditions. The Nkonkola tick fed very quickly. The epidemiological consequence of which is a sudden elevation in the abundance of adults feeding on cattle. And since ECF is dose dependent this could result in epidemics if other factors permitted. The Keemba stock's features and life cycle traits considered in this study and by other workers (Madder *et al.*, 2005) are consistent with it being *Rhipicephalus zambeziensis*. The extended generation time of Keemba (*R. zambeziensis*) ensures more continuous *T. parva* challenge in Southern province thus helping in stabilizing the existing "epidemic" epidemiological status. The Wafa

stock from Eastern province had an intermediate feeding period and showed a dichotomy in nymphal moult. A cohort of nymphs moulted earlier. Adults of these should therefore feed earlier than the second cohort. This agrees with reported spread out feeding of ticks in Eastern province compared to the Southern province and the presence of a second wave of adults. These have been implicated in the differences in the current epidemiological status of the two provinces i.e. first level endemic stable for the Eastern province versus epidemic for the Southern province. Further, this agrees with the dichotomy reported in other ecological features of this tick.

Chapter 5 presents results of intraspecific analysis of genetic variation within the *R. appendiculatus* using mitochondrial COI sequence data. There was strong bootstrap support (ML=99; NJ=100) and high Bayesian credibility values (100) for monophyly of the eastern and Southern province stocks. The two units were considered geographically genetically differentiated rather than ecologically differentiated due to the similarity of the ecological areas of their endemicity. Arising from this genetic distinction and other differences in known ecological features of these tick stocks, it was suggested they be considered different epidemiological management units (EMUs).

Chapter 6 was a cursory comparison of the two geographic genetically differentiated *R. appendiculatus* stocks from Zambia to stocks from Zimbabwe, South Africa and Rwanda. *Rhipicephalus appendiculatus* in the distribution range from east Africa through Zambia to South Africa have been ecologically divided into three groups; the small adult body size with multi-modal phenology of east Africa, medium adult body size with bi-modal phenology of Eastern province of Zambia and large adult body size with uni-modal phenology of southern Africa. Eastern province of Zambia stocks are ecologically considered a transition between the eastern and southern African stocks. The three group ecological characterization was reduced to a two group genetic classification. The east African ecological group and the Eastern province of Zambia transition group were included in one group that was called the eAGG. The Southern province of Zambia stocks were included in the sAGG. Therefore Southern province and Eastern province *R. appendiculatus* stocks from Zambia may be part of two geographic genetically differentiated stocks whose ranges extended beyond Zambia. The data permitted speculation of the origin of Eastern

province ticks, i.e. east Africa and that their introduction into Zambia is more recent than the Southern province ticks.

The seventh chapter was a consideration of intraspecific variation in the *R. zambeziensis* group based on diversity in their mitochondrial 12S rDNA. Neither ecological nor geographical differentiation was supported in these stocks. The number of haplotypes was more for *R. zambeziensis* (7) compared to *R. appendiculatus* for the same segment in the same areas. This high and random variation of haplotypes was attributed to higher variance in reproductive success in *R. appendiculatus* than *R. zambeziensis*. This in turn was attributed to the higher variance in climatic conditions in the areas (mainly valleys) in which *R. zambeziensis* is confined.

In chapter 8 the relationships of variants revealed by different ecological, morphological and molecular studies are assessed using phylogenetic methods on how far they represent monophyletic units especially since the species status of *R. appendiculatus* and *R. zambeziensis* has been questioned. The two main clusters were revealed where an *R. appendiculatus* and an *R. zambeziensis* group. This is consistent with their existing classification as separate species. Morphological intermediates were distributed in either cluster leading to the conclusion that it was impossible to morphologically place correctly every morphological intermediate in their correct nominal taxa and that morphologically identified specimens of *R. appendiculatus* and *R. zambeziensis* in places of mixed occurrence will always be a mixture of both species. Therefore a *BauI* digested ITS2 PCR-RFLP tool for identification of *R. appendiculatus* and an *R. zambeziensis* was unveiled. This could identify specimens to their correct species group an important realization for both taxonomical and epidemiological expediency. The epidemiological significance of this lies in the difference *R. appendiculatus* and *R. zambeziensis* have on the epidemiology of ECF that understandably demands their correct identification. Within the *R. appendiculatus* group the Eastern province ecological group was a monophyletic unit consistent with earlier observations made with the mitochondrial COI analysis.

Chapter 9 evaluates the suitability for PCR amplification of DNA isolated from *Rhipicephalus appendiculatus* material that had been preserved in five different ways, an assessment of tick legs as a source of DNA template and an evaluation of simpler DNA isolation techniques validated for mosquitoes. The *R. appendiculatus* material included fresh (sacrificed just before extraction procedure) and preserved ticks that included, dried, 70% ethanol, refrigerated and cryo-preserved materials. The simplest of the two mosquito validated DNA isolation method was associated with non amplification of DNA by PCR in all the materials. The tick validated method (Boom *et al.*, 1999) had a significantly higher success than the second mosquito validated method of Collins *et al.* (1987). Based on the results of the tick validated DNA isolation method it was concluded that fresh material of *R. appendiculatus* is superior to any preserved material. Drying was the least suitable of the preserved materials. On the other hand, there was no significant difference ( $p=0.814$ ) between cryopreserved material and those preserved in 70% ethanol. This finding was significant because the former has been commended to be the next best thing to fresh material, but material so preserved must be prevented from repeat freeze-thaw cycles, a task that is difficult in Zambia. The latter on the other hand presents the most practical preservation method in areas where maintenance of the cold chain is impossible. This is because materials preserved in alcohol need not necessarily be stored in a refrigerator and the receptacles involved in the storage are simple sample bottles. Tick legs could successfully yield DNA template for PCR amplification and sequencing.

Chapter 10 is an account of a search for *R. zambeziensis* in a collection of *Rhipicephalus* spp. species from Chipata, Petuake and Nyimba. The tool for the search was the *BauI* PCR-RFLP tool. None of the 300 samples of ITS2 amplicons digested with *BauI* gave an *R. zambeziensis* profile upon resolution in 2% agarose gel. The study concludes that if present *R. zambeziensis* must be very rare in the areas sampled. Its absence, however, cannot be confirmed because the areas for which collection reports exist were not sampled. Besides the ecological conditions in some parts of Eastern province resemble those of the Southern province that support *R. zambeziensis*.

Chapter 11 summarizes and discusses the main results of the thesis in broader perspective. This begins with a justification of the use of molecular techniques in combination with phylogenetic analyses in the study of variation, followed by an

emphasis on the taxonomical and epidemiological puzzles created by phenotypic variation in particular, the molecular resolution of the taxonomical tangle and the identification dilemma. With the taxonomical and identification problems having been overcome, the chapter considers the intra-species variation with explanations on the possible existence of such variation and epidemiological implications of the same. The chapter finally offers recommendations for further research on some questions and speculations arising from this work.





## **Chapter 13 - SAMENVATTING**

In het eerste hoofdstuk worden de basisbegrippen aangaande *Rhipicephalus appendiculatus* en *Rhipicephalus zambeziensis* besproken met inbegrip van hun systematische verwantschap met andere teken, hun levenscycli en hun verspreiding in Afrika en in Zambia in het bijzonder. Dit hoofdstuk leidt eveneens de rol in van *R. appendiculatus* en *R. zambeziensis* als vectoren van *Theileria parva*, het infectieuze agens van “East Coast fever” (ECF) bij het rundvee. Eveneens worden de systematische relatie en de cyclus van *T. parva* weergegeven met een korte schets van het economische belang van ECF. Tenslotte worden enkele kenmerken van het klimaat en de vegetatie van Zambia gegeven, in zoverre deze een bepalende rol spelen in de dynamiek en de verspreiding van *R. appendiculatus* en *R. zambeziensis* en in de epidemiologie van ECF.

De verschillende epidemiologische situaties van ECF in de gebieden ter studie worden weergegeven en toegeschreven aan de ecologische verscheidenheid van de vectoren, die de kern bepalen van het tweede hoofdstuk. Het eerste deel van hoofdstuk 2 geeft een inleiding van het concept variatie met de nadruk op intraspecifieke of variatie binnen de species met de taxonomische en epidemiologische vraagstukken ten gevolge daarvan. Pogingen tot het ontrafelen van taxonomische raadsels hebben geleid tot een plethora van zogenaamde species begrippen, van dewelke enkel de morfologische, biologische, evolutionaire, fylogenetische en ecologische species-concepten werden besproken. Begrippen over species worstelen onvermijdelijk met de geschiedenis van het ontstaan van nieuwe species. Enkel de geografische modellen van die ontstaansgeschiedenis met relevantie voor deze studies worden besproken. Vervolgens wordt een overzicht gegeven van vaststaande bewezen feiten, meningsverschillen en leemten in de kennis van de variatie binnen en tussen de species *R. appendiculatus* en *R. zambeziensis*.

Een reeks van fenotypes wordt overlopen, van de duidelijk waarneembare zoals morfologie en gedrag tot de moeilijker observeer- en meetbare zoals biochemische en microscopische karakteristieken. Bij al deze fenotypes werd variatie beschreven zowel binnen als tussen *R. appendiculatus* en *R. zambeziensis*. Enkele fenotypische variaties binnen de *R. appendiculatus* soort werden gekoppeld aan epidemiologische verschillen tussen ECF in oostelijk en in zuidelijk Zambia. Nochtans is de fenotypische variatie tussen de twee erkende soorten niet duidelijk wat resulteert in

een polemiek of deze twee species dan wel zouden behoren tot twee verschillende entiteiten.

Tenslotte wordt in de literatuurstudie de genetische variatie tussen *R. appendiculatus* en *R. zambeziensis* overlopen. Zeer weinig informatie is daar over te vinden, behalve dan wanneer het handelt over de systematiek van *R. appendiculatus* en *R. zambeziensis* op een hoger niveau. Het overzicht besluit met een vermelding over de alomtegenwoordige variatie die geobserveerd kan worden in de algemene morfologie en de DNA structuur van een soort en het belang van genetische variatie van de parasiet te koppelen aan de belangrijke fenotypes van de vector (*R. appendiculatus* en *R. zambeziensis*) zoals vectoriële bedrevenheid, voorkeur voor een gastheer, diapauze, voedingsgedrag en karakteristieken van hun cyclus.

De objectieven van de thesis zijn beschreven in hoofdstuk 3. De algemene doelstelling is een beschrijving te geven van de genetische variatie van *Rhipicephalus appendiculatus/R zambeziensis* en deze te relateren aan hun fenotypische variatie, gezien de vermoedelijke associatie tussen hun fenotypische variatie en de onderscheiden epidemiologische situaties in oostelijk en zuidelijk Zambia. Meer in het bijzonder werden de studies opgezet om:

(1) een beschrijving te geven van de fenotypische en genetische variaties tussen en binnen *R. appendiculatus* en *R. zambeziensis* en fylogenetische methoden toe te passen om uit te maken in hoeverre beide soorten en hun stammen monofyletische eenheden voorstellen.

(2) de best mogelijke bewaringsmethode te bepalen voor moleculaire studies van *R. appendiculatus/zambeziensis* materiaal.

(3) een moleculaire methode te ontwikkelen voor de identificatie van *R. appendiculatus* en *R. zambeziensis*.

In het vierde hoofdstuk zijn de resultaten beschreven van een fenotypische vergelijking (nml. morfologie en aspecten van de levenscyclus) tussen drie stammen van teken, twee van Southern Province (Nkonkola en Keemba) en een van Eastern Province (Wafa). Bij het morfologisch onderzoek werden ter controle *R. appendiculatus* en *R. zambeziensis* van Zuid Afrika gebruikt. De resultaten van deze morfologische studie duiden op een nauwere verwantschap tussen de *R. appendiculatus* controle stam en de Nkonkola stam, wat ook het geval bleek te zijn

tussen de *R. zambeziensis* controle stam en de Keemba stam. Fenotypes van Eastern Province blijken over het algemeen intermediaire vormen te zijn van de *R. appendiculatus* en de *R. zambeziensis* clusters.

Doorgaans kan men de drie zambiaanse stammen wel onderscheiden op basis van de bestudeerde morfologische karakteristieken, maar deze differentiatie is waarschijnlijk weinig praktisch gezien het voorkomen van morfologische tussenvormen. Bovendien is morfologische variatie in de natuur vermoedelijk nog groter door de verschillende levensomstandigheden.

Nkonkola teken voedden zich zeer snel met als epidemiologisch gevolg een plotse overvloed van volwassen voedende teken op het vee en aangezien ECF dosis gebonden is kan dat in bepaalde gevallen tot een epidemie ontaarden. De kenmerken en de levenscyclus van de Keemba stam, die in deze studie en door anderen (Madder *et al.*, 2005) bestudeerd werden doen vermoeden dat deze stam in feite *Rhipicephalus zambeziensis* is. De langere tijd die de ontwikkeling van een generatie Keemba (*R. zambeziensis*) vereist, zorgt voor een meer gelijkmatige *T.parva* bedreiging in de zuidelijke provincie en ondersteunt daardoor het stabiele ‘epidemische’ karakter van de bestaande epidemiologische status.

De Wafa stam van de oost provincie vertoonde een intermediair voedingspatroon met een dichotomie betreffende de nymfale vervelling. Een deel van de nymfen vervelt vroeger, bijgevolg zullen die volwassen ook vroeger voeden dan de rest en dit stemt overeen met het beeld van een meer verspreid voorkomen van voedende adulte teken en het voorkomen van een tweede golf van adulten in de oostelijke provincie en dit in tegenstelling tot de situatie in de zuidelijke provincie. Deze elementen dragen bij tot de verschillen in de huidige epidemiologische status van ECF in de twee provincies, namelijk endemische stabiliteit van het eerste niveau in de oost provincie tegenover een epidemische karakter in de zuidelijke provincie. Deze dichotomie is eveneens waargenomen in andere ecologische eigenschappen van deze teek.

Hoofdstuk 5 geeft de resultaten van een intraspecifieke analyse van genetische variatie binnen *R. appendiculatus* gebruik makend van mitochondriaal COI sequentie gegevens. Een sterke “bootstap support” (ML=99; NJ=100) en een hoge Bayesiaanse aannemelijkheid (100) duiden op monofylie van stammen afkomstig van de oostelijke en zuidelijke provincie. De twee entiteiten werden verondersteld geografisch

genetisch verschillend te zijn eerder dan ecologisch verschillend omwille van de criminaliteit in de ecologische gebieden van voorkomen. Voortvloeiend uit deze genetische verschillen en andere verschillen in ecologische eigenschappen van deze teken stammen, werd er voorgesteld om ze als “different epidemiological management units (EMUs)” te classificeren.

Hoofdstuk 6 geeft een oppervlakkige vergelijking weer van de twee geografische verschillende en genetische gedifferentieerde *R.appendiculatus* van Zambia met stammen afkomstig van Zimbabwe, Zuid Afrika en Rwanda. In zijn verspreidingsgebied gaande van Oost Afrika over Zambia naar Zuid Afrika wordt *R.appendiculatus* ecologisch verdeeld in 3 groepen op basis van hun fenologie en de lichaamsgrootte van het volwassen stadium, namelijk een Oost Afrikaanse kleine teek met multimodale fenologie, de teek van de Eastern Province (Zambia) van middelmatige grootte en met bimodale fenologie en de unimodale grote teek van zuidelijk Afrika. Stammen van Eastern Province worden beschouwd als een overgangsvorm tussen de oostelijke en zuidelijke stammen. Genetisch gezien zijn deze drie ecologische groepen gereduceerd tot twee: de oost Afrikaanse ecologische groep en de transitie groep van Eastern Province zitten samen in één groep, aangeduid als eAGG, stammen uit Southern Province behoren tot de zuidelijke groep, aangeduid als sAGG. Het is dus mogelijk dat *R.appendiculatus* stammen uit Southern Province en uit Eastern Province behoren tot twee geografisch en genetisch verschillende stammen met elk een verspreidingsgebied dat verder reikt dan Zambia. Onze data zijn suggestief voor de hypothese dat de teken van Eastern Province een oost Afrikaanse oorsprong zouden hebben en dat ze meer recentelijk in Zambia geïntroduceerd zouden zijn dan de teken van Southern Province.

Het zevende hoofdstuk handelt over de variatie in de *R. zambeziensis* groep gebaseerd op de verscheidenheid van het mitochondriaal 12S rDNA. Differentiatie in die groep kon noch op ecologische, noch op geografische basis ondersteund worden. Het aantal haplotypes bleek hoger te zijn voor *R. zambeziensis* (7) in vergelijking met *R. appendiculatus* voor hetzelfde segment van dezelfde streek. Deze eerder hoge en willekeurige variatie van haplotypes werd toegeschreven aan de hogere variatie in reproductief succes bij *R. appendiculatus* vergeleken met *R. zambeziensis*, wat op zijn beurt het gevolg is van de sterk variërende klimaatsomstandigheden in die streken (voornamelijk valleien) tot dewelke *R.zambeziensis* beperkt is.

Hoofdstuk 8 geeft de fylogenetische relatie weer van verschillende ecologische en morfologische varianten en een moleculaire techniek wordt beschreven ter identificatie van de twee belangrijke clusters die de fylogenetische analyse aantoonde. Die belangrijkste clusters onderscheidde de *R. appendiculatus*/*R. zambeziensis* groepen, op basis van morfologische, ecologische en ethologische karakteristieken, als afzonderlijke groepen, wat de bestaande classificatie als twee gescheiden species ondersteunt.

Aangezien morfologische tussenvormen in beide clusters gevonden werden, moet men besluiten dat het op morfologische basis onmogelijk is om die tussenvormen correct te identificeren en daar waar ze voorkomen zullen op morfologische basis geïdentificeerde specimen van *R. appendiculatus* en *R. zambeziensis* steeds als een mengeling van beide soorten moeten beschouwd worden. Dit maakt een *BauI* digested ITS2 PCR-RFLP techniek, die dit onderscheid wel kan maken, een belangrijk hulpmiddel voor zowel voor taxonomische als epidemiologische studies. Immers de epidemiologie van ECF is verschillend naargelang de vector *R. appendiculatus* of *R. zambeziensis*, wat de correcte identificatie zo belangrijk maakt. In de *R. appendiculatus* groep van Eastern Province bleek er een monofyletische eenheid te bestaan wat consistent is met eerder gevonden resultaten van COI analyses.

In hoofdstuk 7 worden de resultaten van een verdere analyse van de variatie binnen de groep weergegeven, naar aanleiding van de indicaties van het bestaan van een monofyletische eenheid binnen in de *R. appendiculatus* groep van de twee belangrijkste clusters beschreven in hoofdstuk 6. Het eerste deel van dit hoofdstuk handelt over het aantonen van die entiteit aan de hand van mitochondriaal COI.

In hoofdstuk 9 wordt de geschiktheid voor PCR amplificatie geëvalueerd van materiaal geïsoleerd van *R. appendiculatus* en bewaard op vijf verschillende manieren. Ook wordt het gebruik van teken pootjes als een bron voor een DNA-sjabloon en een evaluatie van eenvoudigere DNA-isolatie technieken beschreven. Deze laatste werden gunstig geëvalueerd op extracties uit muggen. Het *R. appendiculatus* materiaal was ofwel vers (i.e. net vóór de extractie, gedode teken), gedroogd, in 70% ethanol bewaard, gekoeld of cryo-bewaard. De eenvoudigste techniek, gevalideerd voor muggen materiaal, bleek geen amplificatie te geven voor teken DNA ongeacht de bewaring. De voorheen gebruikte extractie methode voor

teken materiaal (Boom *et al.*, 1999) gaf significant betere resultaten dan een tweede methode die positief geëvalueerd werd voor muggen door Collins *et al.*, (1987). Vers materiaal bleek de beste resultaten te leveren, gedroogd materiaal was het slechtste; er was echter geen significant verschil ( $p=0.814$ ) tussen cryopreservatie en bewaring op 70% ethanol. Deze laatste observatie is wel belangrijk want cryopreservatie werd verondersteld het beste te zijn na vers materiaal, echter herhaald vriezen en ontdooien vermindert de kwaliteit. Dit is moeilijk te vermijden in zambiaanse omstandigheden, bewaring op alcohol is er heel wat praktischer bovendien vergt het ook geen bewaring in een ijskast en kunnen eenvoudige monsterflesjes gebruikt worden. Tenslotte bleken tekenpootjes zeer geschikt materiaal voor PCR amplificatie en sequentiëring.

Hoofdstuk 10 geeft een relaas van de zoektocht naar *R.zambeziensis* in verzamelingen van *Rhipicephalus* spp. uit Chipata, Petauke en Nyimba (Eastern Province, Zambia). Tot dit doel werd de *BauI* PCR-RFLP techniek gebruikt. Geen enkele van de 300 monsters van ITS2 amplicons bewerkt met *BauI* gaf een *R. zambeziensis* profiel na resolutie in 2% agarose gel. Deze studie concludeert dat indien dan toch aanwezig in Eastern Province, *R. zambeziensis* maar zelden voorkomt, althans in de bemonsterde gebieden. We kunnen echter niet besluiten dat deze teek er helemaal niet voorkomt, enerzijds werden de streken waar hij gerapporteerd werd niet door ons bemonsterd en anderzijds zijn de ecologische omstandigheden in sommige streken van de provincie wel geschikt voor *R. zambeziensis*.

In hoofdstuk 11 worden de belangrijkste resultaten van dit werk kritisch besproken in een ruimere context. Het begint met een rechtvaardiging van het gebruik van moleculaire technieken in combinatie met fylogenetische analyses ter studie van de variaties, vervolgens wordt het accent gelegd op de taxonomische en epidemiologische raadsels van fenotypische variatie in het bijzonder met het moleculaire antwoord op het taxonomisch kluwen en het identificatie vraagstuk.

Na de behandeling van de taxonomische en identificatieproblemen wordt de intra-species variatie besproken met toelichtingen bij het mogelijke bestaan van die variatie en de epidemiologische gevolgen ervan. Tenslotte worden aanbevelingen gegeven voor verder onderzoek op enkele vragen en hypothesen die door deze studie geopend werden.





## *Curriculum vitae*

Jupiter Mtambo was born on the 16<sup>th</sup> of June 1966 in Chingola, Zambia. He completed five years of high school at Kasama Boys' secondary school in 1985. He proceeded to pursue a degree in Veterinary Medicine at University of Zambia in 1988, which he completed in 1994. The following year he did internship with private practises, one in Zambia and another in Ireland. In 1996, he joined the government service in the Agriculture Food and Fisheries ministry as a veterinary officer responsible for a district. This position was in Solwezi district in the North Western province of Zambia. In 1998 he moved to Mazabuka (in Southern province), on secondment to the Belgian Government funded Project "Assistance to the Veterinary Services of Zambia (ASVEZA) that ended in 2002, as a counter part tick ecologist. It was in the context of that project that this PhD programme was started.

Jupiter Mtambo is a member of the Veterinary Association of Zambia and is registered with the Zambian board of veterinary surgeons.

## **Publications**

- Mtambo, J., W. van Bortel, M. Madder, P. Roelants and T. Backeljau. 2006. Comparison of preservation methods of *Rhipicephalus appendiculatus* (Acari: Ixodidae) for reliable DNA amplification by PCR. *Experimental and Applied Acarology*, 38, 189-199.
- Mtambo, J., M. Madder, W. van Bortel, D. Berkvens and T. Backeljau. 2007. *Rhipicephalus appendiculatus* and *R. zambeziensis* (Acari: Ixodidae) from Zambia: a molecular reassessment of their species status and identification. *Experimental and Applied Acarology*, 41, 115-128.
- Mtambo, J., M. Madder, W. van Bortel, G. Chaka, D. Berkvens and T. Backeljau. 2007. Further evidence for geographic differentiation in *R. appendiculatus* (Acari: Ixodidae) from Eastern and Southern provinces of Zambia. *Experimental and Applied Acarology*, 41, 129-138.
- Mtambo, J., M. Madder, W. van Bortel, D. Geysen, D. Berkvens and T. Backeljau. 2007. **Genetic variation in *Rhipicephalus appendiculatus* (Acari: Ixodidae) from Zambia: correlating genetic and ecological variation with *Rhipicephalus appendiculatus* from eastern and southern Africa. *Journal of Vector Ecology*, 32, 168-175.**
- Speybroeck, N., M. Madder, P. Van Den Bossche, J. Mtambo, N. Berkvens, G. Chaka, M. Mulumba, J. Brandt, L. Tirry and D. Berkvens. 2002. Distribution and phenology of ixodid ticks in southern Zambia. *Medical and Veterinary Entomology*. 16, 430-441.

- Speybroeck, N., M. Madder, H.H. Thulke, J. Mtambo, L. Tirry G. Chaka, T. Marcotty and D. Berkvens. 2004. Variation in body size in the tick complex *Rhipicephalus appendiculatus/Rhipicephalus zambeziensis*. *Journal of Vector Ecology*, 29, 347-354.
- Fandamu, P., L. Duchateau, N. Seybroeck, T. Marcotty, V. Mbao, J. Mtambo, M. Mulumba and D. Berkvens. 2005. *Theileria parva* seroprevalence in traditionally kept cattle in southern Zambia and El Niño. *International Journal for Parasitology*, 35, 391-396.