

Lorenzo Benedetti

**Probabilistic design and upgrade  
of wastewater treatment plants in the  
EU Water Framework Directive context**

Thesis submitted in fulfilment of the requirements for the degree of Doctor (Ph.D.)  
in Applied Biological Sciences

*Dutch translation of the title:*

Probabilistisch ontwerp en aanpassing van afvalwaterzuiveringsinstallaties in de context van de Kaderrichtlijn Water.

*Please refer to this work as follows:*

Benedetti L. (2006). Probabilistic design and upgrade of wastewater treatment plants in the EU Water Framework Directive context. PhD thesis, Ghent University, Belgium, pp. 304.

ISBN-number: 978-9-059891-45-6

The author and the promoter give the authorisation to consult and to copy parts of this work for personal use only. Every other use is subject to the copyright laws. Permission to reproduce any material contained in this work should be obtained from the author.

*Let yourself be open and life will be easier.  
A spoon of salt in a glass of water makes the water undrinkable.  
A spoon of salt in a lake is almost unnoticed.*

Buddha

*to Franciska and Viktor*

Promoter: Prof. P.A. Vanrolleghem (Ghent University)

Ph.D. Review Committee: Prof. Willi Gujer (EAWAG, Switzerland)  
Prof. Ulf Jeppsson (Lund University, Sweden)  
Prof. Wolfgang Rauch (Technical University of Innsbruck, Austria)  
Prof. Willy Verstraete (Ghent University)

Other Jury Members: Prof. Niels De Pauw (Ghent University, Chairman)  
Prof. Henri Spanjers (Ghent University)  
Prof. Ann van Griensven (Ghent University)

Dean: Prof. Herman Van Langenhove  
Rector: Prof. Paul Van Cauwenberge

# TABLE OF CONTENTS

ACKNOWLEDGEMENTS.....	5
LIST OF ABBREVIATIONS.....	7
GENERAL INTRODUCTION.....	11
<b>PART A. LITERATURE REVIEW.....</b>	<b>19</b>
<b>1. Wastewater treatment regulation.....</b>	<b>21</b>
1.1 Europe.....	21
1.1.1 Legislative framework.....	21
Immission-based regulation.....	22
Emission-based regulations.....	23
Design standards.....	24
1.2 USA.....	26
1.2.1 Legislative framework.....	26
Immission-based regulation.....	26
Emission-based regulation.....	28
Design standards.....	29
1.3 Conclusions.....	29
<b>2. Systems analysis.....</b>	<b>31</b>
2.1 Introduction.....	31
2.1.1 The DPSIR framework.....	31
2.1.2 Sustainability of wastewater systems.....	32
Sustainability.....	32
Sustainable technology.....	34
Integrated wastewater systems.....	34
2.2 Substance flow analysis.....	35
2.2.1 Description.....	35
2.2.2 Previous studies.....	36
2.2.3 Handling uncertainty.....	38
2.3 Indicators.....	40
2.3.1 Indicators and DPSIR.....	40
2.3.2 Benchmarking of wastewater systems.....	41
2.4 Conclusions.....	41
<b>3. Modelling the urban wastewater system.....</b>	<b>43</b>
3.1 Models.....	44
3.1.1 Rainfall/runoff.....	44
3.1.2 Sewer.....	44
3.1.3 Wastewater treatment plant.....	45
Steady state modelling.....	45
Dynamic modelling.....	45
3.1.4 River water quality.....	47
3.1.5 Model integration.....	47
3.2 Software.....	48
3.2.1 Integrated Catchment Simulator.....	48
3.2.2 OpenMI.....	49

3.2.3 REBEKA.....	50
3.2.4 SIMBA.....	50
3.2.5 SYNOPSIS.....	50
3.2.6 WEST.....	50
3.3 Problems in integrated modelling.....	51
3.4 Conclusions.....	51
<b>PART B.    WHERE TO IMPROVE THE UWWS.....</b>	<b>53</b>
<b>4. Case study – The Nete River basin.....</b>	<b>55</b>
4.1 Description.....	55
4.2 Data collection.....	57
4.2.1 Meteorological data.....	57
4.2.2 Households’ data.....	57
4.2.3 Industries data.....	59
4.2.4 Agriculture data.....	60
4.2.5 Sewer catchments data.....	60
4.2.6 WWTPs data.....	62
4.2.7 Receiving water data.....	67
4.3 Conclusions.....	67
<b>5. Substance flow analysis.....</b>	<b>69</b>
5.1 Method.....	69
5.2 Problem definition.....	70
5.3 Substance flows.....	73
5.3.1 Calculations.....	73
5.3.2 Results.....	74
5.3.3 Discussion.....	86
5.4 Conclusions.....	87
<b>6. Indicators.....</b>	<b>89</b>
6.1 Adopted indicators.....	89
6.2 Results and discussion.....	92
6.2.1 Values of indicators.....	92
6.2.2 Uncertainties and information gaps.....	99
6.3 Conclusions.....	100
<b>PART C.    HOW TO IMPROVE THE UWWS.....</b>	<b>103</b>
<b>7. Pre-selection of alternatives.....</b>	<b>107</b>
<b>8. Modelling the WWTP influent.....</b>	<b>111</b>
8.1 Tools.....	112
8.1.1 Case with some data available.....	112
8.1.2 Case with no data available.....	113
8.2 Scenarios.....	115
8.3 Conclusions.....	121
<b>9. Modelling WWTP alternatives.....</b>	<b>123</b>
9.1 Tools.....	124
9.1.1 WWTP Models.....	124
9.1.2 Simulation software – WEST and Tornado.....	126
9.2 Scenarios.....	127
9.2.1 WWTP design.....	127
Process configurations and general layout.....	127

Dimensioning.....	131
9.2.2 WWTP upgrade.....	131
Process configurations.....	132
9.3 Conclusions.....	133
<b>10. Modelling for immission-based evaluation.....</b>	<b>135</b>
10.1 Tools.....	136
10.1.1 River model.....	136
10.1.2 Model interfaces.....	137
ASM to RWQM1 interfacing.....	137
The continuity-based interfacing method (CBIM).....	143
Formulation of elemental mass fractions and charge density.....	143
Set- up of the composition matrices.....	143
Definition of the transformation matrix.....	144
Implementation of the transformation equations.....	145
10.2 Scenarios.....	145
10.2.1 The ASM2d to RWQM1 interface.....	145
10.2.2 Integrating WWTP and river.....	150
Investigated scenarios.....	151
10.3 Conclusions.....	153
<b>11. Probabilistic analysis.....</b>	<b>155</b>
11.1 Tools.....	156
11.1.1 Monte Carlo simulation.....	156
11.1.2 Distributed simulations – Typhoon.....	157
Requirements.....	158
Architecture.....	159
Typhoon versus Grid Computing.....	159
11.1.3 Probabilistic descriptors.....	160
Percentile polygons.....	162
The relative reliability index (RRI).....	162
Concentration-duration curves.....	163
11.2 Scenarios.....	164
11.3 Methodology evaluation.....	166
11.3.1 Convergence.....	166
11.3.2 Sensitivity to probability density function.....	167
11.3.3 Calculation burden of simulations.....	170
11.4 Conclusions.....	170
<b>12. Emission-based evaluation of alternatives.....</b>	<b>171</b>
12.1 Evaluation framework.....	172
12.1.1 Environmental performance.....	172
12.1.2 Economic performance.....	173
12.2 Results.....	175
12.2.1 WWTP design.....	175
Volume comparison.....	176
Discussion.....	176
Conclusions.....	176
Process comparison.....	186
Economic performance.....	186
Environmental performance.....	193
Reliability analysis.....	194
Conclusions.....	198

Sensitivity to season.....	199
Sensitivity to cost parameters.....	202
12.2.2 WWTP upgrade.....	205
Economic performance.....	205
Environmental performance.....	208
Conclusions.....	212
12.3 Conclusions.....	213
<b>13. Immission-based evaluation of alternatives.....</b>	<b>215</b>
13.1 Evaluation framework.....	215
13.2 Results.....	216
13.3 Conclusions.....	223
GENERAL CONCLUSIONS.....	225
PERSPECTIVES.....	229
REFERENCES.....	231
SUMMARY.....	243
SAMENVATTING.....	245
APPENDIX A – WWTP DESIGN CONFIGURATIONS.....	249
APPENDIX B – INFLUENT TRANSFORMER.....	259
APPENDIX C – WWTP UPGRADE CONFIGURATIONS.....	265
APPENDIX D – WWTP DIMENSIONED VOLUMES.....	295
CURRICULUM VITAE.....	301



## ACKNOWLEDGEMENTS

My greatest gratitude goes to Peter for all he did for me, from giving me the privilege to work with him being part of BIOMATH, to his constant support with enthusiasm and humour. I recall with delight the meetings we had in antelucan hours, or by finding the right timing to open the office door and get him by deriving his position in the corridor from the Doppler-effect of his noisy shoes, or by following his run to have a technical discussion where people usually do not have...

I express my gratitude to Stefano Marsili-Libelli for his introduction to environmental modelling and for his role in establishing the first contact between me and Peter.

The person from which I learned most of what I know about wastewater treatment is Davide Bixio from Aquafin, for both the scientific and technical aspects. His commitment and kindest help increased substantially the quality of this work.

The other person without whom this work would have not been possible, is Filip Claeys. He provided the precious tools that I needed to run all the simulations I wanted in no time... and always following my whims in terms of nice new features... And thank you Gaspard for having put up with all my bothering about IT problems and requests !

I would like to especially mention my colleagues with which I worked on the CD4WC project both here (Veronique, Webbey, Péter, Anne-Marie, Andrea G., Andrea C., Geert, Chris and Martijn) and abroad (Peter, Frank, Thilo, Gerold, Wolfgang, Sara, Carolina, Stefan, ...).

A special thought to my colleagues and friends, in very sparse order: Ingmar, Ann, Eveline, Katrijn, Frederik, Veerle, Gurkan, Dirk, Kris, Tao, Masha, Jo, Lieven, Klaas and many others...

Many thanks to the members of the reading committee for the time spent to improve the quality of this work.

I want to thank my parents, which first allowed me to spend my MSc thesis period in Ghent some years ago, and then understood that the best thing for me would have had as a consequence to be far away, for who knows how long...

Well, I could not end but expressing my deepest love and gratitude to Franciska and Viktor, my strongest driving force, source (and sink) of energy, and my reason for everything...

Lorenzo Benedetti

Ghent, 19 November 2006



## LIST OF ABBREVIATIONS

A2O – anaerobic-anoxic-oxic

AEC – aeration energy cost

AMINAL – Administratie Milieu,- Natuur-, Land- en Waterbeheer (Flanders' Environment, Nature, Land and Water Management Administration)

AO – anaerobic-oxic

ASM – activated sludge model

BBI – Belgian biotic index

BDN – Biodenitro

BDNP – Biodenipho

BOD<sub>5</sub> – biological oxygen demand after five days

CBIM – continuity-based interfacing method

COD – chemical oxygen demand

CSO – combined sewer overflow

CWA – Clean Water Act

DAE – differential algebraic equation

DO – dissolved oxygen

DOF – degree of freedom

DPF – discharge pollution fee

DPSIR – driving forces, pressures, states, impacts and responses

DS – dry solids

DWF – dry weather flow

EC – energy cost

EQI – effluent quality index

KMI – Koninklijk Meteorologisch Instituut (Royal Meteorological Institute)

HLAS – high loaded activated sludge

HRT – hydraulic retention time

## List of abbreviations

---

LHS – Latin hypercube sampling  
LLAS – low loaded activated sludge  
LLAS\_PS – LLAS with primary settler  
MC – Monte Carlo  
MLSS – mixed liquor suspended solids  
MSL – model specification language  
MWWWE – municipal wastewater effluent  
NPDES – national pollutant discharge elimination system  
OCP – oxygen consumption potential  
OD\_bioP – oxidation ditch with bio-P removal  
OD\_simP – oxidation ditch with simultaneous P precipitation  
ODE – ordinary differential equation  
PAO – phosphorous accumulating organism  
PDF – probability density function  
PE – population equivalent  
PHA – polyhydroxyalkanoate  
PP – polyphosphate  
PPI – Prati index for oxygen  
RBMP – river basin management plans  
RRI – relative reliability index  
RTC – real-time control  
RWQM – river water quality model  
SC – sludge cost  
SFA – substance flow analysis  
SRT – sludge retention time  
SVI – sludge volume index  
SWTP – storm water treatment plant  
TC – total cost  
TKN – total Kjeldahl nitrogen  
TN – total nitrogen  
TMDL – total maximum daily load  
TP – total phosphorous  
TSS – total suspended solids  
TU – toxic unit

UCT – University Cape Town

USEPA – United States Environmental Protection Agency

UWWS – urban wastewater system

VC – variable cost

VE – virtual experiment

VMM – Vlaamse Milieu Maatschappij (Flamish Environmental Agency)

WET – whole effluent toxicity

WFD – Water Framework Directive

WQBEL – water quality-based effluent limit

WQS – water quality standard

WWTP – wastewater treatment plant



## GENERAL INTRODUCTION

### On the problem of where and how to improve the urban wastewater system

The EU Water Framework Directive (WFD) has introduced a crucial change in European policy on protection of water resources, shifting the focus from the control of point sources of pollution (emission-based regulations) to integrated pollution prevention and control at river basin level, setting quality objectives for the receiving waters (immission-based regulations), which are the basis to set the upstream emission limits (see Figure 1). This new approach results in more freedom in basin management – due to the expansion of the boundaries of the managed system, increasing the number or sub-systems to be considered as well as the interactions between them – which can lead on the one hand to a better allocation of economic resources in pollution abatement and introduces on the other hand complexity in the analysis, due to the synergies emerging from the implementation of different measures to different components of the river basin system.

In particular, in order to be able to prioritise interventions, the WFD explicitly requires the development of basin management plans, where the major pressures and impacts on the receiving water are revealed and the measures to reach the water quality objectives are decided. Such plans may be realised by using mostly qualitative analyses of experts, therefore lacking objectivity (quantification) and lacking efficiency in terms of time and costs, possibly failing in identifying the best alternatives and neglecting reliability and uncertainties in the analysis, by just introducing heuristic safety factors.

This work has been carried out in the framework of the EU project CD4WC – acronym for “Cost-effective Development of urban wastewater systems for Water Framework Directive Compliance” – (see [www.cd4wc.org](http://www.cd4wc.org) and Benedetti *et al.*, 2004c). The CD4WC project dealt with optimising the efficiency of the urban wastewater system with regard to ecological consequences in natural water bodies and with regard to investment and operation costs. Criteria to assess the ecological consequences are – besides the water quality – also secondary resource inputs such as energy, materials and chemicals. Various options and strategies to develop the wastewater system were evaluated. Main emphasis was put on the dynamic interactions between the sewer system, the wastewater treatment plant (WWTP) and the receiving water, as well as on the possibilities of taking measures in the receiving water and at the sources. The methods applied were analysis of river basin managers' data to gain insight in experience, the performance of measurement campaigns to close information gaps, numerical modelling to assess systems changes and extensions and economic balancing to evaluate alternative pollution control instruments, such as permits, fees and pollution trading.

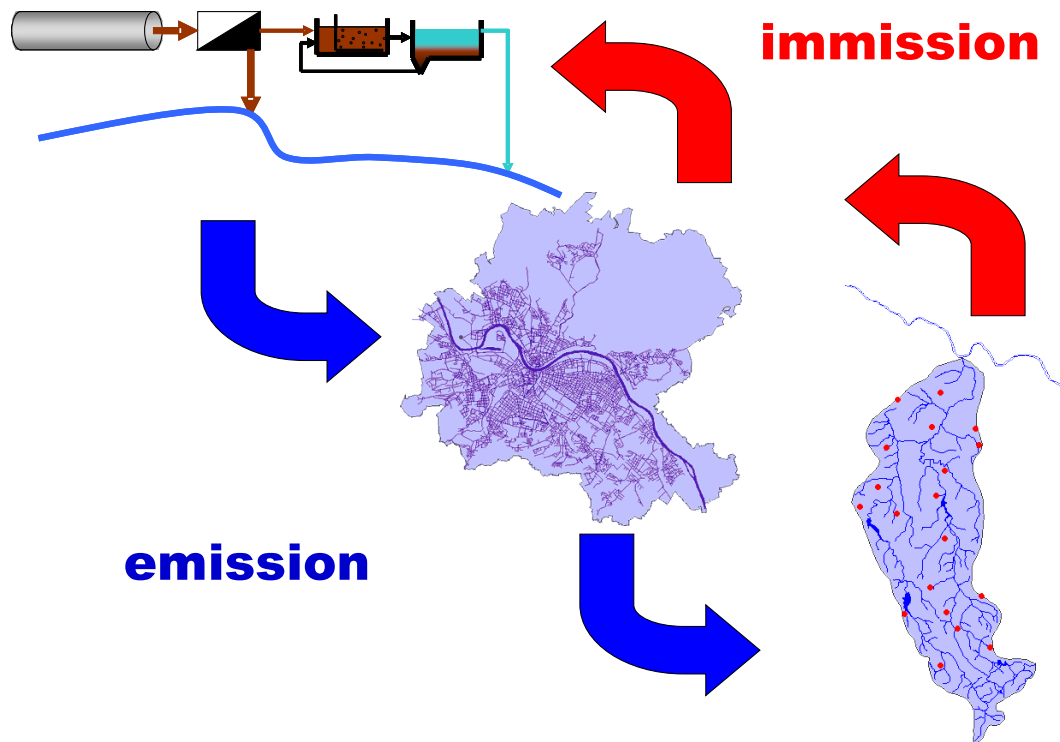

Figure 1: Immission- vs. emission-based approach (Krebs, 2000).

The overall objective of this dissertation is to develop and illustrate a methodology that allows:

1. to identify the critical areas and technical sub-systems in a river basin to prioritise investments, by means of systems analysis;
2. to compare and design wastewater treatment alternatives cost-effectively, by means of dynamic modelling and probabilistic analysis.

As a particular case, the tools developed for the methodology are focussed on the urban wastewater system (UWWS) and specifically for wastewater treatment plants (WWTPs). It is recognised that urban environments may not always be regarded as the major sources of pollution in a river basin (especially in developed countries, where intensive agriculture plays a major role in systems with already strongly reduced point source pollution), nevertheless they still represent a powerful, flexible and responsive “control handle” in river basin governance.

Concerning the terminology used in this dissertation, “basin” refers to the river basin and includes all the area draining water to the closing section of the river. “Catchment” refers to the area (part of the basin) which drains water to a single UWWS, constituted by urban catchment, sewer, WWTP and urban river stretch. “Technical sub-systems” refer to urban catchment, sewer, WWTP, industry, households and agriculture.

Figure 2 and Figure 3 show the flow chart of the proposed methodology for the planning process, which can be divided in two main phases: Systems Analysis and Systems Design.

Systems Analysis (see Figure 2) – intended as the analysis of complex, large scale systems and the interactions within those systems – starts with the problem definition in which the state of the receiving water is assessed and the objectives are set by defining the water uses and the water quality standards.



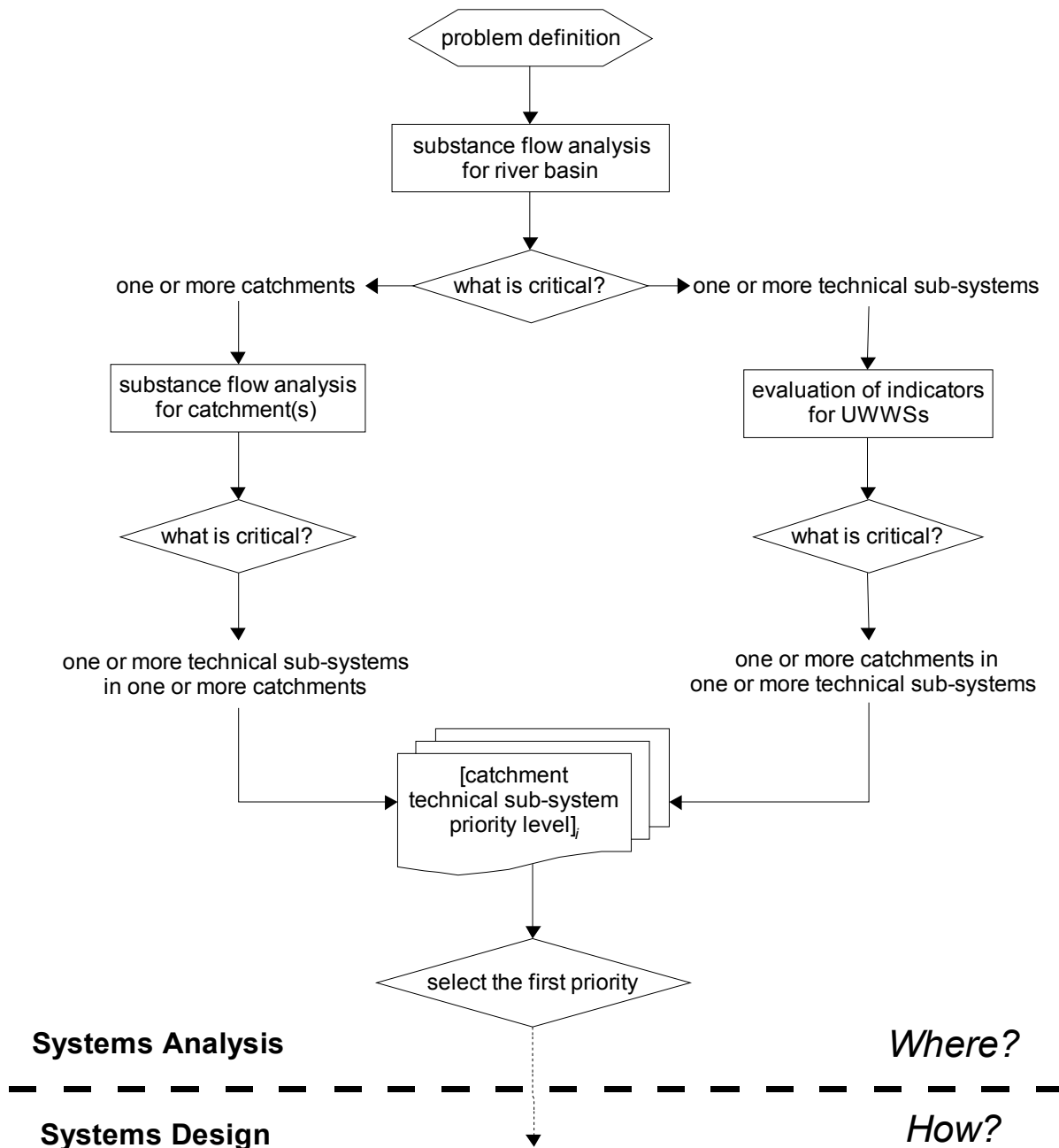

Figure 2: Flow chart of the methodology to plan where and how to improve the UWWs; Systems Analysis.

Then, the interventions in the basin are prioritised, by identifying where (in which catchment, in which technical sub-system and with which priority level) measures have to be implemented. Substance flow analysis (SFA) – which consists of accounting for the flows of a substance to, through and from a system over a determined time period – combined with mass balances are appropriate tools to highlight pressures on the environment, i.e. on the receiving water and to pinpoint information gaps.

After having performed SFA for the river basin, the planner can choose:

- a) to further investigate the catchments which present the more critical situations by refining the SFA at catchment scale, in order to identify which technical sub-systems should be addressed in those catchments;
- b) to further investigate the technical sub-systems which present more critical situations, by evaluating a list of indicators which help to characterise in environmental and economic terms the behaviour of the sub-system in each catchment; this would lead to identify in which catchments there is more need to improve the sub-system system under study; in this dissertation a specific list of indicators was developed for the wastewater collection and treatment system.

These two parallel investigation paths can in certain situations lead to the same list of priorities (list of certain sub-systems in certain catchments which need to be improved, with a defined priority level) or in other situations to a different/overlapping list of priorities. The priority with the highest level is selected from the list to be improved by means of Systems Design (see Figure 3).

At this point, the most interesting alternatives have to be selected among the wide set of measures that can be implemented to improve the state of the receiving water, by gathering and elaborating qualitative information on their feasibility, benefits and cost-effectiveness for the specific situation at hand.

Once the most interesting alternatives are selected to be further investigated, the design phase can begin. With the water quality based approach introduced with the WFD, the design of the systems is by far less predetermined and the options to meet the goals become much more numerous. Therefore new design methodologies must be developed in order to be able to cope with such increased complexity in a cost-efficient way. To be able to quantitatively evaluate the selected set of alternatives, they should be modelled and the simulation results be compared according to defined criteria. As an alternative or complement to modelling, experiments and pilot implementations can be used.

In this dissertation, a specific probabilistic design methodology for WWTP design and upgrade was developed. The assessment is based on environmental performance (emission- and immission-based evaluation) and on economic performance. The probabilistic analysis has been introduced to assess how model input uncertainties are propagated to model outputs, in order to evaluate the reliability of processes under uncertain conditions. In general, with the same average behaviour and the same input uncertainties, a process which has a more stable output is preferable to another one with large uncertainty in its output. Methodologies regarding other technical sub-systems have been developed within the CD4WC project.

The design methodology begins by modelling the WWTP influent, since the length and frequency of (possibly) existing influent data is typically not sufficient to appropriately feed the WWTP models with the desired dynamics which express the natural variability of the influent characteristics. Such available data usually consist of grab or composite samples collected with a frequency varying between daily and monthly, while the systems dynamics have time constants that vary from one month (e.g. sludge age) to a few minutes (e.g. dissolved oxygen variations in the activated sludge tanks, hydraulic and pollutant peaks in rain events). Therefore, the modelled WWTP influent has a data frequency of 15 minutes and a length of one year to cover short-term effects and seasonal variations.

The simulation results (WWTP effluent and operational data, e.g. chemicals dosage and air flows) are elaborated to assess the environmental (emission-based) and economic performance of the alternatives.

In case the immission-based evaluation is required as well, the receiving water (river) has to be modelled and then integrated with the WWTP model by means of a model interface. If necessary, also the uncertainties of the river model are to be characterised. More generally, also rainfall-runoff and sewer models can be integrated for the evaluation. After the Monte Carlo simulation, the effect of the alternative measures on the receiving water quality is assessed.

With the information provided by the performance evaluation (only emission-based or immission-based as well) a decision can be taken on which alternative measure should be implemented.

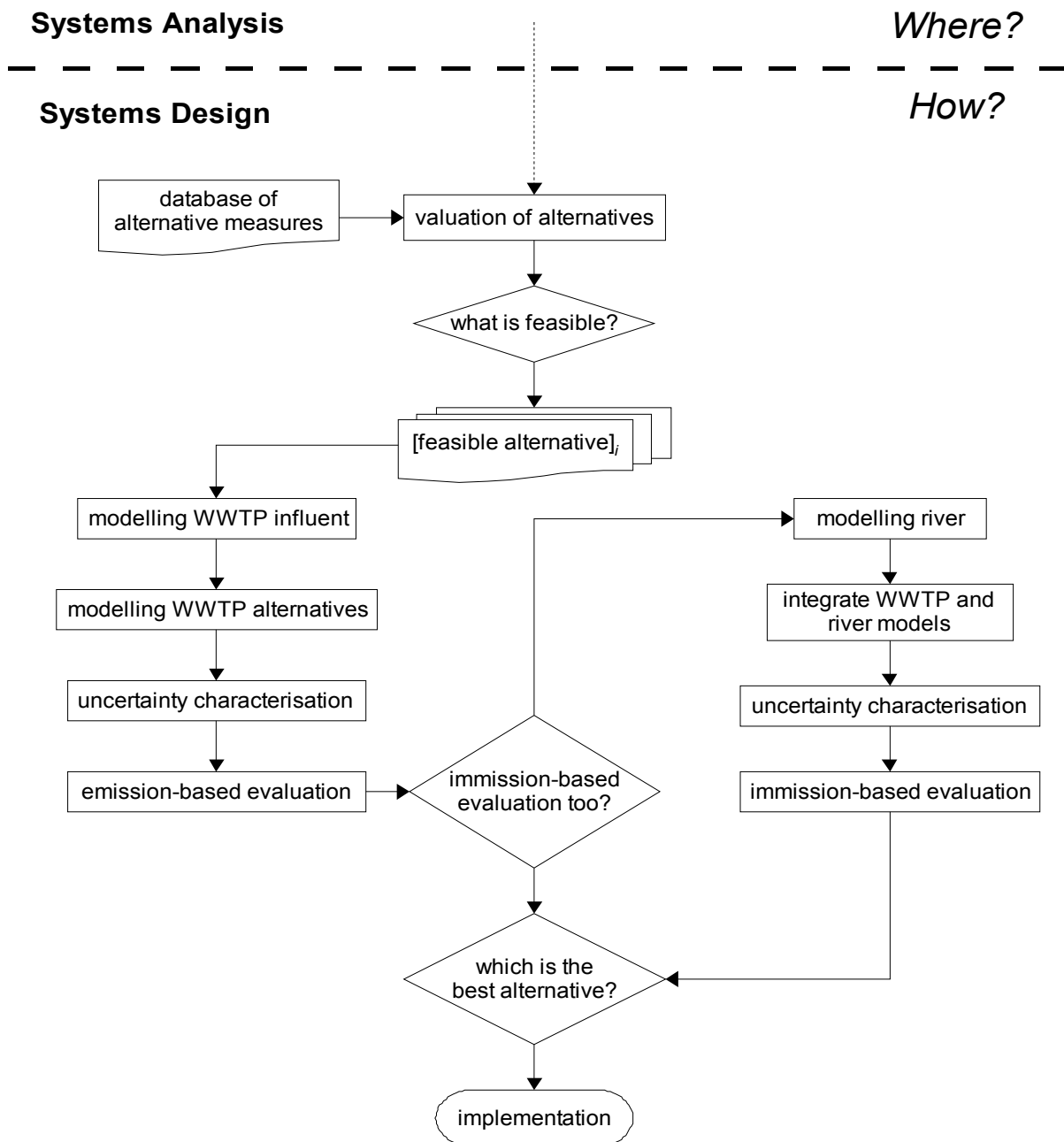

Figure 3: Flow chart of the methodology to plan where and how to improve the UWWS; Systems Design.

Part A of this dissertation (a literature review) opens by setting the problem in its legislative framework (Chapter 1), by illustrating the emission- and immission-based regulations in Europe and in the USA. Systems Analysis is then introduced in Chapter 2 and in particular the tools used in the proposed methodology, which are SFA and the use of indicators. Chapter 3 includes a review of the current models and software used in modelling the UWWS and on the information required to develop the tools used in Systems Design.

Part B aims to answer the question “Where to improve the UWWS?” by means of Systems Analysis. It starts with Chapter 4 by describing the case study – the Nete river basin in Belgium – and the data which have been collected for further analysis. Chapter 5 illustrates the SFA performed for the Nete basin and for its catchments, while Chapter 6 deals with the performance indicators calculated for the sewer collection and treatment systems present in the Nete basin.

The question of “How to improve the UWWS?” is tackled in Part C, which illustrates the process of Systems Design. It starts in Chapter 7 with the valuation of alternative corrective measures to be selected and then compared. The next step is the description of the models realised to generate the WWTP influent time series (Chapter 8) providing two alternatives, one for cases with some influent measurements available and another one for cases with no influent data available at all. The influent characterisation actually used to illustrate the methodology belongs to the second case and its implementation is described in detail. In Chapter 9, the alternative process configurations and the models and software used to implement them are described and the dimensioning/characterisation of them in the scenarios of WWTP design/upgrade is illustrated. Chapter 10 describes the additional modelling (and model interfacing) efforts required in this work to also perform the immission-based evaluation of alternatives. The probabilistic analysis – performed by Monte Carlo simulation – is described in Chapter 11 with the software used to make the methodology feasible and with the descriptors introduced. An evaluation of the validity of this uncertainty assessment is also included for the investigated scenarios. Chapter 12 and Chapter 13 deal with emission- and immission-based evaluations of the alternatives respectively, explaining the adopted evaluation frameworks and the results obtained.

This dissertation ends with the conclusions that can be drawn from this work and with a perspective outlook on the research opportunities to develop the proposed methodology.

### **Contributions of the author to the different chapters and publications that resulted from the work**

In this overview, General introduction, Literature Review (Part A), General conclusions and Perspectives are excluded, since they do not imply specific scientific/technical work for their production. Anyway, they were completely carried out by the author. Publications that have been the result of the work that is described in the different chapters, are provided and also indicate, through the order of authors, the extent of contribution by the author.

#### **Chapter 4 - Case study - The Nete River basin**

The author organised the data gathering from the several data holders (Aquafin, VMM, KMI). The author checked the data for quality and consistency.

#### **Chapter 5 - Substance flow analysis**

The author framed the problem, defined the method, performed all calculations and made all

graphs and interpretation of results.

**Benedetti, L., Dirckx, G., Bixio, D., Thoeye, C. and Vanrolleghem, P.A. (2006)** *Substance flow analysis of the wastewater collection and treatment systems. Urban Water Journal 3(1), 33-42.*

## Chapter 6 - Indicators

The author framed the problem, defined the method, performed all calculations and made all graphs and interpretation of results.

**Benedetti, L., Dirckx, G., Bixio, D., Thoeye, C. and Vanrolleghem, P.A. (2006).** *Environmental and economic performance assessment of the integrated urban wastewater system. Journal of Environmental Management (resubmitted).*

## Chapter 7 - Pre-selection of alternatives

The author initially framed the problem and partially contributed to the compilation of the list.

*Vandenbergh, V., Benedetti, L. and Vanrolleghem, P.A. (2004). Synergetic use of the degrees of freedom to improve the urban wastewater system, In: Proceedings of IWA WWC 2004, Marrakech, Morocco, 19-24 September 2004.*

## Chapter 8 - Modelling the WWTP influent

For the case with some data available, the author contributed to the framing of the problem and to the discussion on the implementation. For the case with no data available, he contributed to the framing of the problem and to the implementation. For the generation of scenarios, he gathered the data, defined the scenarios, ran all simulations and produced all tables and graphs and interpretation of results.

*Devisscher, M., Ciacci, G., Fè, L., Benedetti, L., Bixio, D., Thoeye, C., De Gueldre, G., Marsili-Libelli, S. and Vanrolleghem, P.A. (2006). Estimating costs and benefits of advanced control for wastewater treatment plants - the MAGIC methodology. Water Science and Technology 53(4-5), 215-223.*

*Gernaey, K., Rosen, C., Benedetti, L. and Jeppsson, U. (2005). Phenomenological modelling of wastewater treatment plant influent disturbance scenarios, In: Proceedings of 10<sup>th</sup> International Conference on Urban Drainage (ICUD), Copenhagen, Denmark, 21-26 August 2005.*

## Chapter 9 - Modelling WWTP alternatives

The author implemented all models not already present in the WEST modelbase. He was the first and main tester for Tornado. For plant design, he carried out all dimensioning and implemented all configurations in WEST. For plant upgrade, he framed the problem, carried out some dimensioning and implemented some configurations in WEST. The author He the work of the other contributor to this section.

*Claeys, F., De Pauw, D.J.W., Benedetti, L. and Vanrolleghem, P.A. (2006). Tornado: A versatile and efficient modeling & virtual experimentation kernel for water quality systems, In: Proceedings of iEMSs 2006, Burlington, VT, USA, 10-13 July 2006.*

## Chapter 10 - Modelling for immission-based evaluation

The author implemented all models not already present in the modelbase. He implemented the interface in the modelbase, ran all simulations and produced all graphs and tables and interpretation of results. He contributed to the development of the CBIM interfacing method. He supervised the work of the other contributor for the implementation of the interface with the CBIM method. He implemented the river model, the plant upgrades and integrated them.

**Benedetti, L., Meirlaen, J., Sforzi, F., Facchi, A., Gandolfi, C. and Vanrolleghem, P. A. (2004).** *Dynamic integrated modelling: A case study on the river Lambro. In: Proceedings of the NOVATECH 2004, Lyon, France, 6-10 June 2004.*

**Benedetti, L., Meirlaen, J. and Vanrolleghem, P.A. (2004).** *Model connectors for integrated simulations of urban wastewater systems. In: Sewer Networks and Processes within Urban Water Systems. Bertrand-Krajewski, J.-L., Almeida, M., Matos, J. and Abdul-Talib, S. (eds), pp. 13-21, IWA Publishing, London, UK.*

**Vanrolleghem, P.A., Rosen, C., Zaher, U., Copp, J., Benedetti, L., Ayesa, E. and Jeppsson, U. (2005).** *Continuity-based interfacing of models for wastewater systems described by Petersen matrices. Water Science and Technology 52(1-2), 493-500.*

**Solvi, A.-M., Benedetti, L., Vandenberghe, V., Gillé, S., Schlosseler, P., Weidenhaupt, A. and Vanrolleghem, P.A. (2006).** *Implementation of an integrated model for optimised urban wastewater management in view of better river water quality: A case study. In: Proceedings of IWA World Water Congress 2006, Beijing, China, 10-14 September.*

### Chapter 11 - Probabilistic analysis

The author promoted the development of parallel computing, implemented MC simulation into Typhoon and was the first and main tester of the software. He developed the probabilistic descriptors. He defined and implemented the scenarios based on literature information. He performed all simulations and produced all graphs and interpretation of results.

**Benedetti, L., Bixio, D., Claeys, F. and Vanrolleghem, P.A. (2006).** *Tools to support a model-based methodology for benefit/cost/risk analysis of wastewater treatment systems, In: Proceedings of iEMSs 2006, Burlington, VT, USA, 10-13 July 2006.*

**Claeys, F., Chtepen, M., Benedetti, L., Dhoedt, B. and Vanrolleghem, P.A. (2006).** *Distributed virtual experiments in water quality management. Water Science and Technology 53(1), 297-305.*

**Claeys, F., Chtepen, M., Benedetti, L., De Keyser, W., Fritzson, P. and Vanrolleghem, P.A. (2006).** *Towards transparent distributed execution in the Tornado framework, In: Proceedings of Environmental Applications and Distributed Computing 2006, Bratislava, Slovakia, 16-18 October 2006.*

### Chapter 12 - Emission-based evaluation of alternatives

The author adopted and modified the existing evaluation methods and gathered all data needed for the calculations. For plant design, he ran all simulations, wrote Matlab scripts for data post-processing, produced all graphs and interpretation of results. For plant upgrade, he ran some simulations, wrote Matlab scripts for data post-processing, produced all graphs and interpretation of results.

**Benedetti, L., Bixio, D. and Vanrolleghem, P.A. (2006).** *Assessment of WWTP design and upgrade options: balancing costs and risks of standards' exceedance. Water Science and Technology 54(6-7), 371-378.*

**Benedetti, L., Bixio, D. and Vanrolleghem, P.A. (2006).** *Benchmarking of WWTP design by assessing costs, effluent quality and process variability. Water Science and Technology 54(10), 95-102.*

### Chapter 13 - Immission-based evaluation of alternatives

The author ran all simulations, wrote Matlab scripts for data post-processing, produced all graphs and interpretation of results.

# **PART A**

## **LITERATURE REVIEW**





## WASTEWATER TREATMENT REGULATION

This chapter reviews the design standards and the driving legislative frameworks in Europe and in the USA. In Europe, particular attention is given to Germany, where a specific (stricter) implementation of EU legislation is into force and where one of the most used wastewater treatment design guidelines has been developed.

The legislative context is sub-divided into immission-based regulations (water quality standards) and emission-based regulations (effluent limits).

### 1.1 Europe

#### 1.1.1 LEGISLATIVE FRAMEWORK

The Water Framework Directive establishes a framework for water policy based on the principle of integrated river basin management (Directive 2000/60/EC) which is currently in the initial phase of implementation in the Member States. Linked to this Directive are the Directives relating to :

- Ground water (a new proposal and an existing Directive 80/68/EEC)
- Strategies against chemical pollution of surface water under the Water Framework Directive (including Priority substances under Article 16 of the Water Framework Directive as well as the existing legislation on Discharges of Dangerous Substances Directive (76/464/EEC))

Water pollution coming from urban wastewater and certain industrial sectors is regulated by the Urban wastewater Treatment Directive (91/271/EEC).

The quality of bathing waters in rivers, lakes and coastal waters are regulated by the Bathing

Water Quality Directive (Council Directive 76/160/EEC concerning the quality of bathing water and the new Directive 2006/7/EC).

The quality of drinking water is regulated by the Drinking Water Directive (98/83/EC).

A very recent development is the Commission's proposal for a Directive on the assessment and management of floods.

### **Immission-based regulation**

The EU Water Framework Directive (CEC, 2000) sets ecosystem-based objectives and planning processes at the level of the hydrographic basin and has a major impact on water resources management in Europe (Kallis and Butler, 2001; Griffiths, 2002).

One advantage of the framework directive approach, is that it will rationalise the Community's water legislation by replacing seven of the older directives: the one on surface water and its two related directives on measurement methods and sampling frequencies and exchanges of information on fresh water quality; the fish water, shellfish water and groundwater directives; and the directive on dangerous substances discharges. The operative provisions of these directives will be taken over by the framework directive, allowing them to be repealed.

The WFD introduces an integrated and coordinated approach to and represents an important step forward for, water management in Europe. It rationalises and updates existing water legislation by setting common EU-wide objectives for water. Its key objectives, as set out in Article 1 are to:

- prevent further deterioration and protect and enhance the status of aquatic ecosystems and associated wetlands;
- promote sustainable water use based on long-term protection of available water resources;
- aim at enhanced protection and improvement of the aquatic environment;
- ensure the progressive reduction of pollution of groundwater and prevent its further pollution;
- contribute to mitigating the effects of floods and droughts.

The aim of the WFD is to take a holistic approach to water management, as water flows through a catchment from lakes, rivers and groundwater towards estuaries and thence the sea. Surface and groundwater are to be considered together, in both qualitative and quantitative terms (they are anyway separate in the evaluation procedure).

The objective, as set out in Article 4, is that Member States will be required to achieve by 2015 “good surface water status” and “good groundwater status” and also to prevent deterioration in the quality of those waters, which are already “good”. The definition of “good status” for surface water results from a set of criteria concerning the biological and the physico-chemical statuses, which will be specified with their monitoring approaches and threshold values by the Member States. For this dissertation, the water quality variables taken into account to evaluate the status of the receiving water are described in Chapter 13. No definition of “good” status has been provided, but a comparison of the status induced by different treatment options. The major change of approach in this Directive is that ecological quality is a key means by which, surface waters in particular, will be assessed against “good status” as well as the more traditional assessment of chemical quality. There will be limited exceptions to, or derogation from, achieving these objectives. In particular bodies of water which are artificial in construction or where the physical structure has been irrevocably and

heavily modified will be required to achieve a status of “good ecological potential”. This status is equivalent to achieving good status given the constraints of the physical structure of the water body. Derogation from “good status” is also allowed in unforeseen or exceptional circumstances, such as floods or droughts. In these circumstances Member States must take “any practical means” to restore the water body to its previous status.

The WFD also provides for protection to higher standards through the designation of Protected Areas, for example for water supply, recreational waters, nutrient sensitive waters or nature conservation or economically important aquatic species.

These improvements in water status are to be achieved through a system of analysis and planning based upon the river basin, called River Basin Management Plan (RBMP), which have to be approved by 2009. RBMP is the key administrative mechanism identified in Article 13 of the Directive for the delivery of environmental objectives. RBMP sets out a Programme of Measures for the achievement of “good status” and are to be subject to public consultation by 2008, thus introducing an element of social participation and transparency.

Economic considerations are also an important element of the Directive; Article 9 requires Member States to take account of the costs recovery principle in water services and to make judgements about the most cost-effective combination of measures in respect of water use.

The Directive includes new provisions to regulate pollution from Dangerous Substances. These provisions include the establishment of a Combined Approach, which permits the use of both Environmental Quality Standards and fixed Emission Limit Values.

The provisions of the WFD will apply to all inland surface waters, ground waters, transitional water (including estuaries and coastal lagoons) and coastal waters (to one nautical mile from the baseline).

Up to today, no practical regulation has stemmed from the definition of “good” ecological status of the WFD. The Urban wastewater Directive will still be in force and probably more stringent effluent limits will be introduced where and when necessary. On the other hand, it is also argued that in some cases less stringent effluent limits should be set in case this is allowed by the state and resilience of the receiving water, in order to use the limited economic resources more effectively (De Toffol *et al.*, 2005).

## **Emission-based regulations**

In the European context, the performance of wastewater treatment has to fulfil the EU Urban wastewater Directive (91/271/EEC, later amended by 98/15/EEC), implemented by Member States in national legislation. The objective of the Directive is to protect the environment from the adverse effects of discharges of urban wastewater and of wastewater from industrial sectors of agro-food industry. This EU Directive outlines universal standards for end-of-pipe compliance at all secondary treatment facilities. The standards are expressed as either numerical limits or percentage reduction values for COD, BOD<sub>5</sub> and TSS parameters.

Alternate/additional end-of-pipe limits are also applied to facilities that discharge into waters at high elevation and/or into waters classified as ‘sensitive areas’ and ‘less sensitive areas’. For these areas, population equivalent (PE) provisions for each parameter may be implemented. ‘Sensitive areas’ include water bodies that are eutrophic or are susceptible to eutrophication, as well as water bodies from which potable water is collected. In addition to the aforementioned parameters, total nitrogen (TN) and total phosphorus (TP) limits that take PE into account are applied to treatment

facilities that discharge to sensitive areas. Less stringent limits (including the complete absence of limits) may apply to large water bodies (i.e., estuaries, coastal areas) that exhibit high water exchange and are not susceptible to eutrophication (or likely to become eutrophic) or do not experience oxygen depletion due to the discharge of urban wastewater. These areas are referred to as ‘less sensitive’.

Apart from identification of ‘sensitive’ and ‘less sensitive’ water bodies, the end-of-pipe limits do not take receiving environment conditions and/or dilution ratios into account for derivation of the limits.

See Table 1 for the numerical values of effluent limits throughout Europe.

### Design standards

No European-wide design standards have been drafted so far for wastewater treatment plant design. Most of the Member States have their own standards or guidelines providing advice for good design practice, but they are usually just suggesting broad ranges of design parameters (e.g. ANPA, 2001).

However, one of the most adopted guideline all over Europe is the German “Standard ATV-DVWK-A 131E, Dimensioning of Single-Stage Activated Sludge Plants” (ATV, 2000), or “ATV-A 131” in short. This standard gives clear guidance on how to estimate influent flow and loads, the biological reactors and the secondary settling tank. The objective is to dimension plants treating domestic (or equivalent) wastewater by means of biological BOD, COD, N and P removal, which meet the achievable minimum effluent requirements of the German Wastewater Ordinance (AbwV, see Table 1) and the associated sampling regulations.

ATV-A 131 derives the dimensioning of the fundamental aerated volume of nitrifying plants from the following parameters:

- sludge volume index (SVI) which implies a certain TSS concentration in the tank
- sludge age, function of temperature and plant size
- sludge production, function of sludge age, temperature and ratio of total and biodegradable COD in the influent

To be noted is that to the sludge age, a safety factor is applied to the aerated sludge retention time (SRT) according to the plant size, equal to:

- 1.8 for plants < 20,000 PE
- 1.6 for plants > 20,000 PE and < 100,000 PE
- 1.45 for plants > 100,000 PE

The denitrification volume is given as a function of the ratio between N to be denitrified and influent BOD. The anaerobic volume for P-removal is suggested on the basis of a minimum contact time. The secondary clarifier is dimensioned assuming a SVI and a thickening time, which is a function of the plant type.

Given the rather strict German effluent standards – requiring effluent limits to be respected on 2-h composite samples, for at least 4 out of 5 samples with the 5<sup>th</sup> one not surpassing the limit by more than 100% – the ATV-131 design results to be highly conservative, leading to large volumes, which are very likely to meet the treatment requirements, but also to be very expensive.

Country	Legislation	Category	BOD				COD		Total Nitrogen		Total Phosphorous		Ammonia		
			General	Monthly	Weekly	Removal	General	Removal	General	Removal	General	Removal	General	Monthly	Weekly
			[mg/l]	[mg/l]	[mg/l]	[%]	[mg/l]	[%]	[mg/l]	[%]	[mg/l]	[%]	[mg/l]	[mg/l]	[mg/l]
general	EU UWWTD 91/271/EEC	2 000 – 10 000 PE	25			70 – 90	125	75							
		10 000 – 100 000 PE	25			70 – 90	125	75	15	70 – 80	2	80			
		> 100 000 PE	25			70 – 90	125	75	10	70 – 80	1	80			
Germany	wastewater Ordinance June 2004 (Federal Law Gazette I p. 1106)	Size Category 1 Less than 60 kg/d BOD <sub>5</sub>	40				150								
		Size Category 2 60 to 300 kg/d BOD <sub>5</sub>	25				110								
		Size Category 3 300 to 600 kg/d BOD <sub>5</sub>	20				90						10		
		Size Category 4 600 to 6,000 kg/d BOD <sub>5</sub>	20				90		18		2		10		
		Size Category 5 larger than 6,000 kg/d BOD <sub>5</sub>	15				75		10		1		10		

Table 1: Emission limits in Europe.

Another crucial aspect of ATV-A 131 is that it cannot take into account and therefore adapt to different effluent requirements or other local factors like climate, water quality standards, social and economic constraints, etc. Therefore, it may not be the most suitable tool to design WWTPs in the complex and flexible water management domain introduced by the WFD.

## 1.2 USA

### 1.2.1 LEGISLATIVE FRAMEWORK

Authorized by the Federal Water Pollution Control Act (33 U.S.C. 1251 *et seq.*, 1972), better known as the Clean Water Act (CWA) after its major amendment in 1977, point source discharges to surface waters, including municipal wastewater effluents (MWWE), are regulated under the National Pollutant Discharge Elimination System (NPDES) permit programme. In most cases, the USEPA has delegated the responsibility for NPDES permits (and therefore, regulation of MWWE) to each State while retaining oversight of the programme. Minimum water quality standards (WQS) are set by the EPA, but states with delegated authority can set more stringent requirements.

The Clean Water Act requires each State to identify those waters for which existing required pollution controls are not stringent enough to implement State water quality standards. For these waters, States are required to establish total maximum daily loads (TMDLs) according to a priority ranking.

NPDES permits are typically issued at five-year intervals on a site-specific basis, taking into consideration the impact of the proposed discharge on the quality of the receiving water relative to the State WQS. Effluent limits are specified in the NPDES permit to ensure that receiving water discharges do not exceed the State WQS criteria.

### Immission-based regulation

The CWA requires that every State develops WQS applicable to all water bodies within the State. Guidance for WQS is provided in the USEPA (1994) Water Quality Standards Handbook. The WQS, which must be reviewed/ revised on a three year basis, must be approved by the USEPA and should:

1. include provisions for restoring and maintaining the chemical, physical and biological integrity of State waters;
2. provide, wherever attainable, water quality for the protection and propagation of fish, shellfish and wildlife and recreation in and on the water (“fishable/swimmable”);
3. consider the use and value of State waters for public water supplies, propagation of fish and wildlife, recreation, agriculture, industrial purposes and navigation.

The WQS are composed of three key parts. The first part of the WQS involves use designations for water bodies based on an assessment of beneficial uses of those water bodies. The CWA describes various “desirable” uses for water bodies that should be protected, including public water supply, recreation and propagation of fish and wildlife. More specific uses (e.g., cold water aquatic life, agricultural and other sub-classifications) or uses not indicated in the CWA may be designated according to State values, as long as they support the defined “fishable/ swimmable” goals.

The second part of the WQS includes numerical and/or narrative water quality criteria sufficient to protect each of the designated uses assigned to the specific receiving water body. Numerical criteria define the magnitude (the allowable concentration of a specific parameter), duration (the period of time over which the in-stream concentration is averaged for comparison with criteria concentrations) and frequency (how often criteria may be exceeded) for each of up to 126 priority parameters as summarized in the USEPA *Gold Book* (i.e., Quality Criteria for Water, USEPA 1986; 2002) and other site-specific parameters, as required. States may establish numerical criteria using EPA guidance (e.g., USEPA, 1991) modified to reflect site-specific conditions or other scientifically defensible methods, or use EPA derived limits. The WQS numerical water quality criteria may be values expressed as levels (e.g., pH), constituent concentrations or mass loadings (e.g., metals, organic compounds), toxicity units (e.g., whole effluent toxicity) or numbers deemed necessary to protect designated uses (e.g., biological indices). The EPA criteria for the protection of aquatic life address both short-term (acute) and long-term (chronic) effects on both freshwater and saltwater species. Human health criteria are designed to protect people from exposure resulting from consumption of water or fish/shellfish.

The WQS narrative criteria may supplement numerical criteria or provide the basis for limiting discharge of specific parameters where the State has no numerical criteria for the parameter or to limit toxicity where the toxicity cannot be traced to a specific pollutant. In general, the narrative criteria are statements that describe the desired water quality goal (e.g., requiring that discharges be “free from toxics in toxic amounts” or “free of objectionable colour, odour, taste and turbidity”). The use of toxicity testing and whole effluent toxicity (WET) limits is generally based upon narrative water quality criteria and/or in some cases a numerical criterion for toxicity (either expressed as a threshold toxic effluent concentration or as toxic units (TU)) may be incorporated into the WQS. The WQS criteria may vary from jurisdiction to jurisdiction, but derivation of the water quality-based effluent limits (WQBEL) has generally followed guidance outlined in the Technical Support Document for Water Quality-based Toxics Control (USEPA, 1991). Inclusion of additional biological, sediment and wildlife criteria is currently encouraged by the USEPA and these criteria are likely to be incorporated as part of the NPDES permitting programme in the future.

The third part of the WQS includes adoption of an antidegradation policy that includes the methods used to implement the policy. Antidegradation policies generally provide three tiers of protection from degradation of water quality:

- Tier 1 includes protection of water uses in existence as of November 28, 1975, the date of EPA’s first WQS regulation.
- Tier 2 includes protection of water quality necessary to support propagation of fish, shellfish, wildlife and recreation in waters that currently meet the applicable criteria. Before water quality in Tier 2 waters can be lowered there must be an antidegradation review to ensure adequate management, technology and controls have been applied and to ascertain the degradation is justified and in the public best interest based on economic or social considerations. In these cases, site-specific alternative criteria may be established for the receiving water body.
- Tier 3 antidegradation protects the quality of outstanding national resources (e.g., waters of national or State parks, wildlife refuges, water of exceptional recreational or ecological significance). With the exception of short-term and temporary changes in water quality, no new or increased discharges are permitted to Tier 3 waters or their tributaries.

### Emission-based regulation

Section 301 of the US Clean Water Act required all publicly owned treatment works (POTW) to achieve effluent limits based on secondary treatment by 01/07/1977 and additional requirements based on Best Practicable Wastewater Treatment had to be met by 01/07/1983.

Effluent limits specified in the NPDES permit consider both the technology available to treat the effluent (i.e., technology-based effluent limits) and protection of designated uses of the receiving water (water quality-based effluent limits). Technology-based regulations apply to all MWW treatment plants and represent the minimum level of effluent quality attainable by secondary treatment. If, after technology-based limits are applied, the permit writer projects that a point source discharge may exceed any WQS criterion in the receiving water, a water quality-based effluent limit (WQBEL) must be imposed. WQBELs involve a site-specific evaluation/characterization of the MWW itself and its effect on the receiving water.

The technology-based regulations provide secondary treatment standards as well as provisions for special considerations regarding combined sewers, less concentrated influent wastewater for combined and separate sewers, industrial wastes, trickling filters, waste stabilization ponds and discharges to marine environments.

Secondary treatment standards include limitations for BOD<sub>5</sub>, TSS, pH, etc.. Equivalent-to-secondary treatment limits, which are less restrictive than the secondary treatment standards, may be applied to facilities with trickling filters or waste stabilization ponds (in part, to prevent costly treatment plant upgrades) and secondary treatment plants under various geographical, climatic or seasonal conditions that cannot meet secondary treatment efficiencies. However, receiving water quality must not be adversely affected by the discharge.

In some cases, alternative State requirements (ASRs) may be established (based on climatic or geographic location, the type of technology used, or any other supportable criteria) allowing higher limits than either the secondary treatment standards or the equivalent-to-secondary limits.

The general process for determining whether technology-based regulations are sufficient or whether WQBEL are required is described in the Technical Support Document for Water Quality-based Toxics Control (USEPA, 1991) and the NPDES Permit Writers' Manual (USEPA, 1996). This is briefly summarized here.

The need for determining WQBEL permit limits for the protection of aquatic life or human health may not require facility-specific effluent monitoring data. In these cases, dilution ratios, type of treatment facility, existing data (either historical data applicable to the specific facility or other similar treatment facility data may be used), compliance problems or toxic impact history and the type of receiving water body and its designated uses must be taken into consideration to determine whether the discharge will exceed, has the reasonable potential to exceed, or contributes to exceeding an ambient (WQS) criterion.

In cases in which effluent characterization is utilized, pollutants of concern are identified (based on historical effluent monitoring data and reports, knowledge of industry discharges to the facility, etc.) and analytical effluent monitoring data (8 to 12 samples analysed for *Gold Book* parameters is the recommended minimum) are collected. The State WQS may require that chemical-specific, whole effluent toxicity (WET) and biological criteria be utilized.

Based on the effluent concentration of each pollutant of concern and the effluent dilution at the edge of the mixing zone, models are used to produce estimates of the receiving environment parameter concentration under various flow regimes (e.g. 7Q10 (the lowest stream flow for seven



consecutive days that would be expected to occur once in ten years), annual average). Generally, the applicant is responsible for providing the characteristics of the discharge (e.g., effluent flows, effluent characterization data, mixing zone details, WET values) to the appropriate regulatory authority in determining WQBEL.

The regulatory authority then determines the expected concentration of each effluent parameter in the receiving water. Each resulting parameter concentration is then compared to the numerical and/or narrative WQS based on the most restrictive human health (reference ambient concentration) and/or aquatic life (acute and chronic toxicity) criteria. If this evaluation projects that a criterion (or criteria) exceeds or has reasonable potential to cause or contribute to exceeding the WQS criterion, WQBEL permits are required. If no reasonable potential for exceeding the WQS criteria exists, no WQBEL are required for the NPDES permit period. However, technology-based effluent limits must still be applied. For those parameters requiring WQBEL, waste-load allocations (WLA) or total maximum daily loads (TMDL) are determined and permit limits are developed for the facility.

A TMDL is a calculation of the maximum amount of a pollutant that a water body can receive and still meet water quality standards and an allocation of that amount to the pollutant's sources. A TMDL is the sum of the allowable loads of a single pollutant from all contributing point and non-point sources. The calculation must include a margin of safety to ensure that the water body can be used for the purposes the State has designated it for. The calculation must also account for seasonal variation in water quality. A TMDL provides a detailed water quality assessment that provides the scientific foundation for an implementation plan. An implementation plan outlines the steps necessary to reduce pollutant loads in a certain body of water to restore and maintain human uses or aquatic life. The development of TMDLs and implementation plans are often the best method to improve water quality.

## Design standards

The Water Environment Federation (WEF) has published a comprehensive textbook on the design of municipal wastewater treatment plants (WEF, 1998). In contrast to ATV-A 131, it provides design parameters for biological nutrient removal configurations (e.g. UCT, A2O, Bardenpho, etc.) which slightly differ as a function of the configuration, instead of being unique. Other commonly accepted references are the books of Tchobanoglous *et al.* (2002) and Vesilind (2003).

In the USA too, design guidelines are just suggesting rather broad ranges of design parameters, like in most of European Member States.

## 1.3 Conclusions

Emission-based regulation is a firmly established reference for effluent quality of WWTPs. In the USA it is already from about 30 years accompanied by immission-based regulation, which require to apply water quality standards according to the specificity of the receiving water body. Such standards allow to derive – by means of the TMDL calculation – effluent limits for the pollution sources in a river basin.

The recent introduction of the WFD makes the “combined approach” of emission- and immission-based regulation the legislative framework to set effluent limits to discharges in the receiving waters. RBMPs are the planning instruments to achieve the goals set by the Directive.

Their first implementation is only required by 2009, so no examples of water quality based emission standards are available so far in Europe.

The design practice for WWTPs in Europe is mostly influenced by the German ATV-131 guidelines, which are rather conservative (with large safety factors) and not flexible to adapt to complex instruments like RBMPs, with case-specific emission limits, climate, social and economical contexts. Neither in the USA there are universally adopted guidelines, but rather a few commonly accepted references.

## SYSTEMS ANALYSIS

In this dissertation, Systems Analysis lays the foundation for the subsequent phase of Systems Design by performing a thorough and wide-focused study of the integrated wastewater system, by describing the fluxes going through the system and by identifying critical paths of pollution, energy consumption as well as operational and investment costs.

This chapter puts the activities to be performed in order to achieve the above mentioned objectives in a general framework (the DPSIR model) and introduces the concept of sustainable wastewater systems. Then the investigation tool used – Substance Flow Analysis – is described together with the evaluated indicators and the methodology adopted to reach the goal of the present study.

### 2.1 Introduction

#### 2.1.1 THE DPSIR FRAMEWORK

The DPSIR framework (EEA, 1999) is a general framework for organising information the about the state of the environment and it is recommended for reporting on environmental issues.

As shown in Figure 4, this framework consists of five components, namely Driving forces, Pressures, States, Impacts and Responses.

The framework assumes cause-effect relationships between interacting components of social, economic and environmental systems, which are:

- Driving forces of environmental change (e.g. increase of population)
- Pressures on the environment (e.g. discharges of wastewater)

- State of the environment (e.g. water quality in rivers and lakes)
- Impacts on population, economy, ecosystems (e.g. water unsuitable for drinking water production)
- Response of the society (e.g. watershed protection)

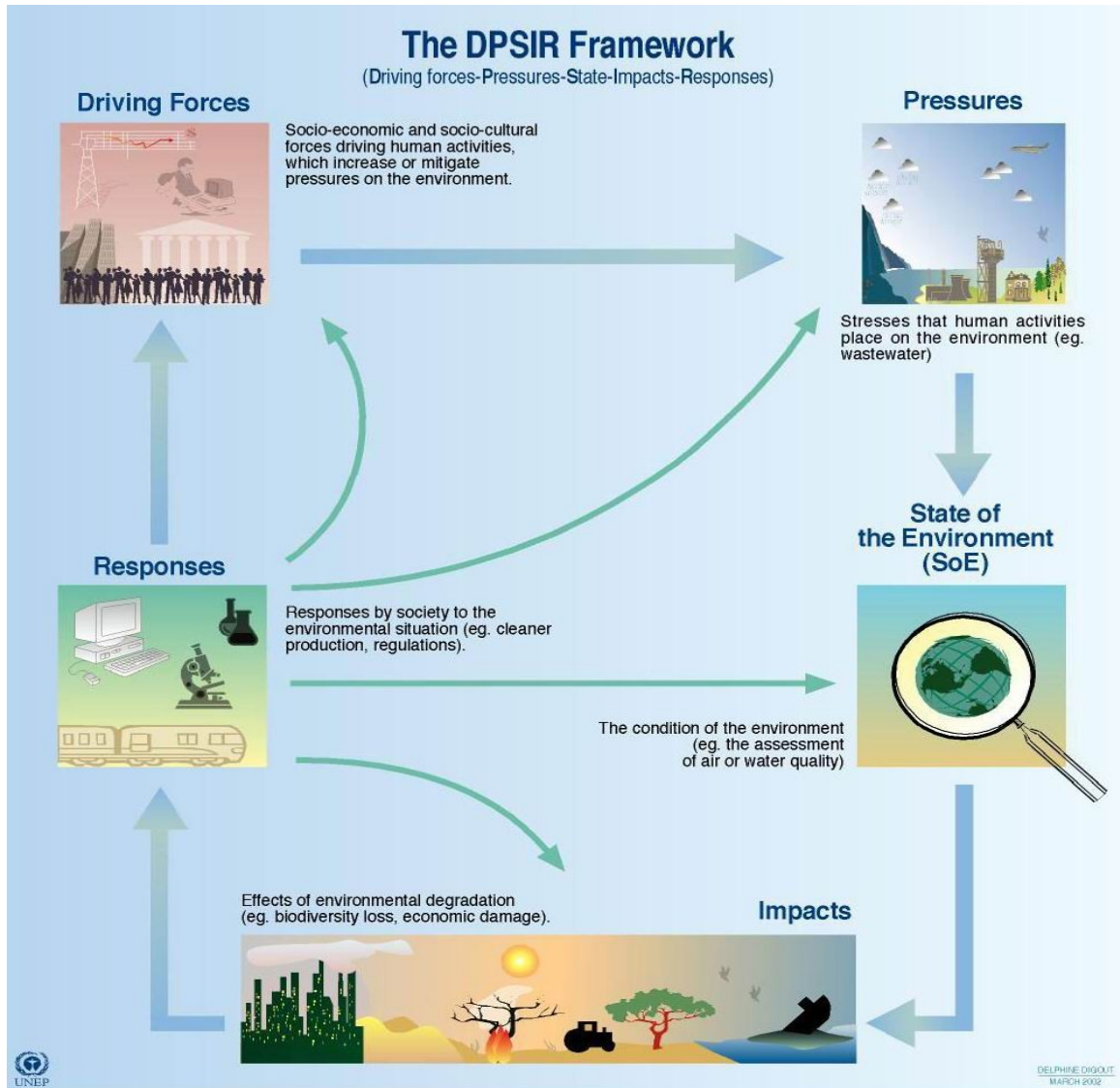

Figure 4: The DPSIR framework (source: UNEP Vital Water Graphics).

## 2.1.2 SUSTAINABILITY OF WASTEWATER SYSTEMS

### Sustainability

Sustainability provides a useful concept, forcing people to think about where development is leading us.

The concept of sustainable development is based on the observation that economy, environment and well-being can no longer be separated.

The definition of sustainable development is often quoted from the World Commission on Environment and Development: “development that meets the needs of the present generation without compromising the ability of future generations to meet their own needs”. The fundamental principle behind this definition is to accept that all human individuals have equal rights, whether living today or in the future. This sketches a concept rather than giving a rigid rule that can be applied right away. Therefore, sustainability can and will be interpreted differently by different people, evoking the critique that the term sustainability could mean almost anything. However, the room left for interpretation proves to be valuable as ideas about sustainability are destined to be discussed over time and place, since different generations will have to deal with different problems and different cultures and local circumstances will give different perspectives on these problems.

The multi-dimensional character of sustainability is fundamental. Three dimensions can be defined, namely economic, environmental and social-cultural (Balkema *et al.*, 2002):

- *Economic*: economic sustainability implies paying for itself, with costs not exceeding benefits. Mainly focussing on increasing human well-being, through optimal allocation and distribution of scarce resources, to meet and satisfy human needs. This approach should, in principle, include all resources: also those associated with social and environmental values (e.g. in environmental economics). However, in practice most analyses include only the financial costs and benefits.
- *Environmental*: the long-term viability of the natural environment should be maintained to support long-term development by supplying resources and taking up emissions. This should result in protection and efficient utilisation of environmental resources. Environmental sustainability refers to the ability of the functions of the environment to sustain the human ways of life. The latter mainly depends upon the ethical basis: to what extent should policies be anthropocentric and to what extent does nature have endogenous qualities. Although public opinion goes further, public policies mainly remain limited to so-called use-values, which can be incorporated in economic analysis relatively easily.
- *Social-cultural*: the objective is to secure people’s social-cultural and spiritual needs in an equitable way, with stability in human morality, relationships and institutions. This dimension builds upon human relations, the need for people to interact, to develop themselves and to organise their society. It can be suggested that sustainable development is an interaction between the biological, economical and social systems, with the goal to optimise across these systems by taking into account the trade-offs. The difficulty to express and weigh these trade-offs suggests that the optimisation is a political process rather than a scientific one. When implementing the concept of sustainability, uncertainties and mutual dependencies between environment and society cannot be ignored. The forthcoming risks for environment and for economy will have to be balanced.

The multidimensionality expressed by the definition of sustainable development emphasizes that thinking in terms of economic costs and benefits is no longer sufficient; social, cultural and environmental aspects have to be incorporated into the decision-making process, especially with regard to long-term effects. Since the most common definitions of sustainability are rather vague and imprecise, it is beneficial to use sets of criteria – like health and hygiene, social-cultural, environmental, economic, functional – to make the concept of sustainability more operational and practically useful (Hellström *et al.*, 2000).

## Sustainable technology

In analysing the sustainability of technology, the different dimensions mentioned above should be taken into account. To avoid export of the problem over time or space, the solution should be based on a long and global view (Balkema *et al.*, 2002).

Realising that the solution is embedded in a complex entirety, one must aim at an integrated solution. Furthermore, a diversity of sustainable solutions must be available for different situations, preferably flexible to adapt to future changes.

The demands of the end user are translated into functional criteria that must be fulfilled by the technology. In order to fulfil its function the technology draws from resources in its environment and affects this environment through contamination.

Sustainable technology is technology that does not threaten the quantity and quality (including diversity) of the resources. As the quantity and quality of the resources and the resilience of the environment to emissions change over time and space, the most sustainable technological solution will change accordingly.

## Integrated wastewater systems

Conventional wastewater solutions, including water-flush toilets, combined sewerage and centralised treatment, did not lead to an integrated solution (Balkema *et al.*, 2002). The mixing of the different wastewater streams makes recovering of the different resources such as water, energy and nutrients, difficult. In addition, dilution of wastewater streams containing pathogens and toxic compounds, such as heavy metals and organic micropollutants, makes treatment more complex and requires higher levels of resources such as energy, money, space and expertise, while still posing pressure on the environment through emissions.

Technology offers a wide range of alternative solutions, for instance storage of rainwater in the sewerage system, rainwater infiltration, usage of rainwater for toilet flushing, vacuum toilets, urine separation, anaerobic digestion, etc. These may be interesting constituents of more sustainable wastewater treatment systems. However, probably the most important question today is whether it is possible to attain more sustainable urban water management through improving the existing centralised systems or whether it is necessary to switch to new decentralised systems.

Some authors (Schertenleib and Gujer, 2000) suggest that environmental sanitation problems should be solved with priority in the context in which they arise (e.g. local treatment for a small settlement); only when it is not possible and when it is sensible to do otherwise, the problems are transferred to a wider context (e.g. centralised collection and treatment system). The output of solid and liquid waste can be minimized within the considered context by (a) the specific reduction of waste-producing inputs such as water, materials and goods and by (b) systematic recycling and reuse within each nested context.

It is extremely important for professionals and decision-makers (especially in developing countries) to realise that even in industrialized countries conventional approaches in urban water management are questioned and new strategies and concepts are developed. One big obstacle to actually implement such new approaches, is that it is politically easier to justify construction costs than to receive financial support for creative efforts to analyse and optimize existing installations (Larsen and Gujer, 1997). Extensive reviews of problems identified in the process of developing sustainable water management are available (e.g. Huang and Xia, 2001; Brunner and Starkl, 2004; Starkl and Brunner, 2004; Starkl *et al.*, 2005).

On the other hand, it should also be recognised that centralised systems are still the best option in some cases and – most important issue – they already exist; therefore they require constant efforts in terms of maintenance and performance optimisation.

## 2.2 Substance flow analysis

### 2.2.1 DESCRIPTION

One of the most general and fundamental ways of analysing a process or a system of processes is by means of substance flow analysis. The approach is based on the law of mass conservation. Substance flow analysis (SFA) refers to accounts in physical units (usually in terms of mass) comprising the extraction, production, transformation, consumption, recycling and disposal of materials (e.g. substances, raw materials, base materials, products, manufactures, wastes, emissions to air, water or soil). Consequently, it provides a way to include the entire urban water system (wastewater, storm water and drinking water) in one general framework where the effects of other associated systems, such as solid waste handling, may also be included when necessary (Jeppsson and Hellström, 2002).

Different substance flows are associated with different environmental impacts. Substance flows can exert eco-toxic, nutritional, mechanical, physico-chemical, structural and energetic effects on the environment. SFA has the advantage that substance flows can be accounted for without knowing all direct and indirect, short-term and long-term, local and global effects.

Substance flow analysis provides information that goes beyond singular indicators by monitoring the inter-linkages of different flows and their interdependencies with human activities. Especially the integrated environmental and economic accounting will profit from the further establishment of SFA. The value of those integrated accounts could be used for the design and control of an effective substance flow management in order to increase the environmental performance of economic activities.

SFA studies the fluxes of resources used and transformed as they flow through a region, through a single process or via a combination of various processes (Belevi, 2002). It analyses the flux of different substances through a defined space and within a certain time. An SFA is a systematic inventory of the way a chemical element, a compound or a substance is passing through its natural and/or economic cycle.

Usually an SFA is based upon the physical balance principles:

- law of conservation of mass;
- law of conservation of energy;
- biological and chemical conversion of molecules.

SFA allows planners and decision makers to identify the key processes for environmental protection and resource recovery in a region. This method allows assessing the critical emissions to air, water and soil and an early detection of possible hazards. Based on this information, the most effective measures and strategies can be chosen. An optimum resource recovery system can be designed by using a combination of relevant mass and substance fluxes.

The goals of an SFA can be to:

- observe raw substances through the system;
- demonstrate linkages in the process;
- retrace waste and emissions back to the place where they were produced;
- demonstrate weak points (inefficiencies);
- elaborate the basis of evaluation;
- present data in view of decision making;
- give priority to sensible measures for waste and emission minimization.

The main limit of SFA is the uncertainty usually lying underneath the data used, which are also of different nature and origin (Danus and Burström, 2001). Therefore, using SFA as a tool for priority setting and follow-up is associated with considerable difficulties. However, SFA is still a useful tool for screening in order to identify areas for further and more detailed investigation.

For an extensive and detailed overview on available tools for systems analysis see (Balkema *et al.*, 2002) and (Finnveden and Moberg, 2005).

### 2.2.2 PREVIOUS STUDIES

In this paragraph, some results and comments found in literature on flow analysis of nutrients in wastewater systems are presented. It is important to note that the results of such studies depend heavily on the system boundaries assumed in the analysis.

High nutrient loads and their consequences are recognised as one of the most severe pollution problems in rivers, lakes and the sea. Additionally, the resource “nutrient” can be limited either by their availability in minerals (P) or the energy needed to produce mineral fertilisers (N). Therefore, nutrients have to be managed in view of environmental protection and of resource management. The basis to develop a nutrient emission control policy for a river basin is to understand nutrient cycling in the environment and the anthroposphere. This means that one must know the major sources, stocks, sinks and pathways of nutrients within the catchment area (Lampert and Brunner, 1999).

Environmentally relevant N and P emissions from traditional centralised municipal water systems are only released into aqueous environments. There are no atmospheric emissions: ammonia (NH<sub>3</sub>) is not released from wastewater (essentially a dilute solution) and emissions of nitrous oxide (N<sub>2</sub>O) do not play a significant role (Larsen, 1999).

Nitrogen is released into aquatic environments predominantly in the form of nitrate (NO<sub>3</sub><sup>-</sup>). Emission loads from agriculture and municipal wastewater systems are usually of the same order of magnitude. Nitrate from agriculture is mainly released into the groundwater (which eventually contributes to pollution in rivers), while inputs from municipal wastewater mainly end up directly in surface waters (Larsen, 1999).

In a wastewater treatment plant, three distinct mass fluxes can be represented: wastewater, outgasing (stripping) and sewage sludge.

During the degradation of organics, the biological treatment step typically immobilises 20% of the nitrogen and 40% of the phosphorus by incorporation into biomass. Depending on the subsequent treatment of the sludge, more than half of the nitrogen can be released again and fed back into the biological treatment stage via the digester supernatant. Any phosphorus released is



typically retained in the concentrated sludge because of precipitation reactions (Larsen, 1999; Battistoni *et al.*, 2000).

In chemical P-elimination treatment systems, 80-95% of the influent phosphorus can be retained in the sludge by addition of iron or aluminium salts. When strict effluent limits apply, an additional filtration step may be necessary at an additional cost. Biological N-elimination (denitrification) typically removes 30-40% of the input nitrogen and can be achieved by relatively simple means (i.e. small preceding denitrification zone). If further denitrification is required, larger basins are needed and the cost increases faster than the degree of nitrogen elimination.

An obvious alternative to phosphorus elimination is phosphorus recycling to agriculture. A few arguments in favour of this solution are (Larsen, 1999):

- phosphorus reservoirs are limited; current estimates predict depletion in a few hundreds years;
- the quality of phosphorus reservoirs is decreasing; the concentration of heavy metals and the cost of production will increase;
- sooner or later, phosphorus will have to be recycled and it could, therefore, be economically advantageous to simultaneously recycle other nutrients;
- the minimization of material fluxes is one of the main strategies in reducing anthropogenic impacts on the environment and, at the same time, fits into the concept of ecological agriculture.

Another study on nutrient cycles (Lampert and Brunner, 1999) shows the importance of the agricultural sector in the Danube basin: more than half of the nutrient emissions (P and N) originate from farming, about 20% stems from private households and about 10-13% from industry. They also point out that wastewater is the second most important input from the viewpoint of future emission reduction strategies. About 65% of the N and P in wastewater stems from private households and the remaining 35% originate mainly from industrial wastewater. Manure is also treated in agricultural wastewater treatment plants in that region.

In the Danube basin, the overall removal efficiency from wastewater is only 15% for N and between 15-20% for P. This is calculated as the sum of nutrient removal through sewage sludge, the content of septic tanks applied on agricultural soils and emissions to the “troposphere” (i.e. denitrification, but this is of negligible importance in the Danube basin) divided by the total input. It is evident that the Danube basin can be considered as a particular case, because of the low nutrient removal achieved.

From the remaining N and P, about 40-45% of the N and 55% of the P are discharged into surface waters via effluents from sewage treatment plants (including treated manure), about 20-25% of the N and P are discharged directly into surface waters and about 30% of the N and 15% of the P percolate into the groundwater. Hence, the nutrient removal efficiency of wastewater management is rather low and far from any optimised nutrient management. The present wastewater management emits large amounts of N and P to the environment (groundwater, surface waters) causing negative impacts and wasting nutrients.

Lampert and Brunner (1999) conclude that the balances of individual processes indicate that resource management needs to be improved, especially in agriculture, but also in the wastewater management sector. Improvement in the management is needed if nutrients are accumulated or if they are transferred into other environmental compartments or into compounds unavailable for plants.

Another important remark is that the observation of stocks is crucial. Measures taken in agricultural practice or in wastewater management in order to reduce nutrient losses into surface waters (erosion) or into groundwater (percolation from soils or from septic tanks) will show delayed effects due to the stocks built up in the soils and the groundwater in the last decades.

An interesting study of SFA in urban water context was performed by Ahlman (2006). He developed and calibrated a dynamic model to predict substance fluxes (including nutrients) in urban wastewater systems to evaluate strategies for stormwater management.

### 2.2.3 HANDLING UNCERTAINTY

Interpretation through SFA may as well include a discussion about the uncertainties involved. The quality of the data used in order to quantify stocks and flows often is not uniform (Lindqvist-Östblom *et al.*, 2001). Some data could be based on actual measurements of the substance studied, while others are more or less qualified estimations of the content e.g. in a certain product. Accordingly, this implies a wide range regarding the certainty of the results. Besides, in order to calculate the stock or flow of a substance, different data are often combined, which could imply a loss in transparency regarding the quality of the data.

The uncertainty of emission estimates of individual countries is around 50% (Lampert and Brunner, 1999). It is smaller on the total scale of large rivers and in countries with abundant data sets. Reasons for these large uncertainties are first the presence of large interacting fluxes which limits the strength of cross-checking. Second, data are used, in which country emissions are basically “conventional wisdom” estimates derived by using simplified computational procedures and a number of assumptions for flows of goods (erosion, base flow, denitrification, etc.), as well as various factors influencing material flows (fertiliser application, manure production, their losses, estimation of stocks, nutrient content of soil, tightness of septic tanks etc.). In addition, good data is scarce in several sectors. Consequently, due to the lack of data, probably some of the assessments can be biased. As a result, for instance, the uncertainty in the quantification of the effects of management strategies for the agricultural sector on erosion/runoff and base flow is quite high.

Available data on nutrient concentrations in surface waters is generally insufficient for estimating annual nutrient loads and therefore to verify the results stemming from materials accounting estimates. From the view of materials accounting total nitrogen and total phosphorus concentrations would be needed.

The transport of total nutrients at high flow conditions might be important but is hardly known. Thus, for water quality monitoring it is recommended to put a much stronger focus on monitoring under various flow conditions at important sites (large tributaries, high emission zones, before and after river stretches with high sedimentation rates, country borders and at final discharge points).

The method used in this work to investigate data uncertainty (Danius and Burström, 2001) was originally designed to evaluate data uncertainties in urban heavy-metal metabolism and is based on uncertainty intervals. The aim was to find the maximum upper limit of the confidence region since the project focused on potentially toxic substances. The level of uncertainty is determined for each collected data set. These data are then added and/or multiplied and the uncertainties are calculated for the results with specific formulas. In this uncertainty calculation approach, uncertainty increases when data are multiplied and decreases when added (see formulas below).

$$m_{a \times b} = m_a \times m_b$$

$$f_{a \times b} = 1 + \sqrt{(f_a - 1)^2 + (f_b - 1)^2}$$

$$m_{a+b} = m_a + m_b$$

$$f_{a+b} = 1 + \frac{\sqrt{[m_a \times (f_a - 1)]^2 + [m_b \times (f_b - 1)]^2}}{m_a + m_b}$$

m = likely value

f = uncertainty factor

Instead of defining the uncertainty interval as  $\pm X$ , it is defined as  $*/X$ . This interval shows the magnitude of variation for the entity. For example, the interval  $100*/2$  is 50-200. For some examples of uncertainty intervals related to the origin of data, see Table 2.

Table 2: Uncertainty factors with examples in a nitrogen flow study (Danus and Burström, 2001)

Uncertainty factor	Source of information	Example
interval $*/1$	Values in general (from literature).	Molecular weight.
interval $*/1.1$	Official statistics on local, regional and national levels.	Number of households, apartments and small houses.
	Values in general (from literature).	Nitrogen content in products.
	Information from facilities subject to permit requirement.	Nitrogen emissions from facilities.
interval $*/1.33$	Official statistics on regional and national levels.	Amount of harvest per hectare.
	Values in general for content (from literature or on request).	Nitrogen content in products (e.g. wood, organic waste)
interval $*/1.5$	Modelled data from the municipality.	Emissions of $\text{NO}_x$ from vehicles.
	Information on request from authorities.	Emissions of $\text{NO}_x$ from traffic.
interval $*/2$	Official statistics on national level downscaled to local level.	Amount of harvest per hectare.
	Information on request from authorities.	Nitrogen emissions from facilities.
interval $*/4$	Values in general for flows (from literature or on request).	Emissions of $\text{NH}_3$ from livestock farming.

When the flows that constitute the nitrogen metabolism are analysed without consideration of data uncertainties, it appears that certain conclusions can be drawn concerning the relative importance of pollution sources to the total load on the environment. But when data uncertainty is considered, the conclusions are not so easily made. In the situation where SFA is used as a tool for priority setting, it can happen that two flows that earlier seemed to be of the same importance, can in extreme situations have such a large uncertainty that the real value of one of the two flows is twice as large as the real value of the compared flow. On the other hand, flows that seemed to be

very different may turn out to be equal.

There are also difficulties when comparing emissions from point sources with emissions from diffuse sources since the difference in data uncertainty more or less hinders the comparison.

## 2.3 Indicators

Within this dissertation, extensive use was made of indicators to facilitate the decision process which the study itself is supporting.

Indicators are widely used to summarize knowledge about the environment, so that the information can be exploited in policy and decision making.

Particular attention should be paid to the creation and use of indicators for environmental-human interactions, considering the points of view provided by the various disciplines dealing with this topic (Hukkinen, 2003).

### 2.3.1 INDICATORS AND DPSIR

The main properties and functions of parameters in the DPSIR framework are presented below (Jesinghaus, 1999):

- Driving force indicators are not very responsive (“elastic”), in fact the monitored phenomena, e.g. road traffic, are driven by powerful economic forces and therefore it can hardly be expected that these trends will change drastically in the future. However, driving force indicators are useful to:
  - calculate a variety of pressure indicators, e.g. by multiplying the mileage of cars with specific coefficients like “average CO<sub>2</sub> per car and km”;
  - help decision-makers to plan actions (“responses”) needed to avoid future problems (“pressures”), for example the capacity of roads;
  - serve as a basis for scenario development and long-term planning.
- Pressure indicators point directly at the causes of problems. One specific feature of pressure indicators is that they should be responsive, that is, a decision-maker has indeed a chance to reduce the indicator (and thus the problem) by launching appropriate actions. They will also serve as an incentive for rational solutions, since they demonstrate the effectiveness of political action early enough to hold those responsible that launched the action. Examples: toxic emissions, parking space required by cars, amount of waste produced by scrap cars.
- State indicators, in contrast, are often too slow. For example, a state indicator showing the acidity of forest soils points back to the NO<sub>X</sub> and SO<sub>2</sub> emissions of the last ten years. On the other hand, state indicators can serve to make a first assessment of the situation (what is the current state of the forest soils? where could corrective measures be applied?) and they are certainly appropriate tools to plan habitat restoration and similar clean-up activities.
- Impact indicators react even slower than state indicators. When the impacts are felt, it is usually too late for action. In addition, it is rarely possible to establish solid statistical

correlations between pressures, state and impacts, due to the enormous delays and the influence of non-environmental variables. The main purpose of impact indicators is to demonstrate DPSIR patterns, in particular cause-effect chains and to facilitate informed discussions about actions to avoid negative impacts in the future. In this sense, they are not statistical “indicators”, but scientific “decision models”. Example: the number of people starving due to climate-change induced crop losses.

- Response indicators are very fast, since they monitor the measures which are intended to make the slow socio-economic system move. Examples:
  - rising energy prices due to the introduction of an energy tax can be observed immediately, while the full effects of this measure (decreasing energy use and CO<sub>2</sub> emissions due to behavioural, technological and other adjustments) will be noted only five to ten years later;
  - the volume of money spent by public authorities and industry for environmental protection measures can serve as a quick indication whether appropriate actions have been launched.

There is no a priori guarantee, however, that political responses (actions, measures, instruments, budget increases...) will be useful and efficient; the monitoring of success can be performed only through Pressure and State indicators.

### 2.3.2 BENCHMARKING OF WASTEWATER SYSTEMS

Indicators are widely used to compare the performance of existing wastewater collection and treatment systems, an activity usually referred as “benchmarking”. Several studies have been carried out in different countries, sometimes using commonly adopted indicators, sometimes introducing new indicators according to the specific requirement of the study. Some examples can be found in: Balmér (2000); Bode and Grünebaum (2000); Stemplewski *et al.* (2001); Lindtner *et al.* (2004).

A broader effort to provide a systematic framework to performance indicators for wastewater utilities – under the umbrella of IWA – has generated a book containing a comprehensive list of indicators, guidance on how to produce them and a software to facilitate the process (Matos *et al.*, 2003).

## 2.4 Conclusions

SFA and performance indicators are described in this chapter and were used in this dissertation as the tools to evaluate where an integrated urban wastewater system would benefit more from applying corrective measures.

Concerning SFA – as for the other available tools of systems analysis – there is not yet a wide and long experience in studying wastewater systems. The use of performance indicators is also a recent practice, but it is having large success especially to benchmark WWTPs and sewer systems due to the increasing pressure on utilities to cost-effectively provide high levels of service.



## MODELLING THE URBAN WASTEWATER SYSTEM

Mathematical modelling of complex systems like sewers, WWTPs or rivers is useful for several reasons. A mathematical model can serve as a compilation of knowledge available about the system; it might be used as a training tool for plant operators, in planning and management of the system or for testing several upgrading options. Mathematical modelling in the integrated urban wastewater system has a long history, especially the modelling of the separate subsystems. Recently, integrated modelling studies were carried out to evaluate the effect of certain measures on other parts of the system.

Integrated models consist of several submodels. The integration of the different components of the urban drainage system in a single model allows for better understanding of (1) the working of the system as a whole and (2) the mutual interaction between its components. This is clearly essential for the evaluation of the system performance as well as for the detection of the system's weak points, in the context of the development of environmentally and economically sustainable planning and management practices.

However, as appeared from many studies conducted in the last few years, a major challenge in water quality management is the application of an integrated approach to the management of municipal water systems, in view of the increasing knowledge of dynamic interactions. Indeed, the expansion of system boundaries allows to determine and potentially model interactions with bordering subsystems which may uncover new management options (Krebs, 1996; Rauch *et al.*, 1998; Rauch *et al.*, 2002a) or possible problems in meeting water quality standards (e.g. for the presence of mixing zones, as illustrated by Jirka *et al.*, 2004).

Two approaches are available to develop an integrated model: a sequential approach and a simultaneous approach. The first implies the use of the three models (sewer, WWTP, river) that are run one after the other over the whole simulation period, using the output of one model to feed the next model. In this case, fluxes proceed in the forward direction. Conversely, in a simultaneous approach all elements in the system are computed simultaneously. Parallel simulations are necessary as soon as feedback fluxes appear (e.g. information used upstream within real-time

control applications or backwater effects from one subsystem to another (Pleau *et al.*, 2001)). Evidently, simultaneous model simulations are much heavier from a computational point of view and, as a consequence, they are generally only carried out when such an effort is required, e.g. when real-time control is applied.

The approach to the software implementation of the integrated model is related to the two approaches mentioned above. One can either merge different software tools in such a way that sequential simulation of the integrated system is possible. When simultaneous simulation is necessary, some coordinating software is necessary to exchange information (either directly or via files) between the different tools used. Another possibility is to use a common simulation platform where the complete UWWS is created by assembling a set of elements (pipes, structures, basins, river reaches, etc.).

### 3.1 Models

#### 3.1.1 RAINFALL/RUNOFF

The main source of water in the urban drainage system is not wastewater, but stormwater or rainwater. During a rain event, rain falls on surfaces and a part of it enters the sewer system via overland flow. Modelling the integrated urban wastewater system hence requires rainfall data as model input. Models that calculate the runoff take into account several basic phenomena like infiltration, interception, evaporation and storage in depressions. Runoff is also influenced by the permeability of surfaces. Different types of models can be used to describe the overland flow process ranging from very detailed (kinematic wave description) to more simple (reservoir models, time-area relations or unit hydrographs) Refer to Butler and Davies (2000) and Chow *et al.* (1988) for extensive information of rainfall/runoff models.

#### 3.1.2 SEWER

There are two different ways to model sewer systems: deterministic models and conceptual models. Deterministic models are based on the de Saint-Venant equations. Several commercial software packages have implemented these equations and dedicated numerical methods to solve them. Moreover, hydraulic equations for manholes, overflows, weirs and other structures present in the sewer system are provided. Usually, a GIS interface is provided to enter information (connections, dimensions, slopes, locations, etc.) about pipes and other structures and to show results. The database containing all this information is the actual model of the sewer system and might be used to simulate the behaviour of the real system. In this way, the model may be used to gain insight in the system, to test renovation options or to test control strategies. Examples of software packages are SWMM (USEPA), Infoworks (Wallingford Software), HYSTEM-EXTRAN (ITWH) and Mouse (DHI).

The deterministic modelling of sewer hydraulics has, as mentioned above, several drawbacks, e.g. long calculation time and the need for detailed information about the system. Moreover, it might not always be necessary to calculate the flow in every single pipe in the system. Often the simulation of input-output behaviour at certain important points might be sufficient. In this case, simplified conceptual models are useful. Most conceptual models are based on the Nash cascade,



which models the flow in sub-catchments by conceptually routing it through a series of linear reservoirs. In this cascade, the input of the downstream tank is the output of the previous tank. Some software packages, like KOSIM in Germany, are based on this principle.

### 3.1.3 WASTEWATER TREATMENT PLANT

#### Steady state modelling

There are several software products on the market that facilitate the dimensioning of WWTPs by using steady state models like the ones described in ATV-A 131 or in other design guidelines (e.g. Bohnke, 1989). Some examples are:

- Aqua Designer (<http://www.bitcontrol.info>)
- CAPDET Works (<http://www.hydromantis.com>)
- Plan-It STOAT (<http://www.wrcplc.co.uk/software>)

They support the whole design process as a function of influent characteristics and desired effluent, allowing to choose for a wide range of treatment processes from pre-treatment to polishing. The software calculates volumes, flow rates, hydraulic dimensioning, piping and cost estimates in very short calculation times, since only simple algebraic equations have to be solved. They provide great flexibility and detailed information for planning and preliminary dimensioning of WWTPs.

Thanks to the low computational requirements, these models can easily be used in complex design tools using artificial intelligence, which require the models to be run many times, but allows to rank different options, to reuse design records, etc. (Roda *et al.*, 2000).

The major drawback of such tools is that they cannot incorporate any dynamic information on the influent and climate characteristics, nor to provide dynamic information on the effluent of the plant.

#### Dynamic modelling

WWTP models are the ensemble of activated sludge biodegradation model, hydraulic model, oxygen transfer model and sedimentation tank model needed to describe an actual WWTP. The term activated sludge model is used to indicate a set of equations that represent the biological (and chemical) reactions taking place in one activated sludge tank.

At the moment, the modelling of activated sludge systems is widely practised, both in research and practical applications. With the introduction of ASM1 (activated sludge model n°1) in the 1980s, a first “standard” model was introduced to describe carbon removal and nitrification/denitrification processes. This model has been widely used as a basis for further model development (Henze *et al.*, 2000). In the mid-1990s, ASM2 and its later extension ASM2d were introduced. This model describes, next to the carbon and nitrogen removal of ASM1, also processes related to biological phosphorus removal. In 1998, ASM3 was developed to overcome some defects of the ASM1 model, which became apparent during the intensive research performed on the basis of ASM1. For a comprehensive review on the state of the art and use of such models, see Gernaey *et al.* (2004b).

As stated by Gujer (2006), activated sludge modelling is a mature technology and more efforts should be directed towards actually using such models in practice rather than developing new models with very small marginal return on (intellectual) investment.

WWTP dynamic models are implemented in software simulators which vary from general-purpose environments to specific tools (Olsson and Newell, 1999; Copp *et al.*, 2002). Some examples of simulators used for wastewater treatment modelling are:

- AQUASIM (<http://www.aquasim.eawag.ch>)
- BioWin (<http://www.envirosim.com>)
- GPS-X (<http://www.hydromantis.com>)
- SIMBA (<http://www.ifak-system.com>)
- STOAT (<http://www.wrcplc.co.uk/software>)
- WEST (<http://www.hemmis.com>)

These software tools allow to run simulations of process layouts, to calibrate (manually or automatically) the models, to test control strategies and alternative configurations, with the great advantage of considering the dynamic behaviour of the processes involved.

The advantages of dynamic models over steady-state models are:

- possibility to explore process characteristics which are intrinsically dynamic (e.g. in alternating systems or in different seasons or in plant start-up);
- evaluation of the effect of control strategies;
- identification of operational problems;
- comparison of effluent concentrations with time-dependent effluent limits posed by some regulations (e.g. 2 hour composite sampling in Germany).

The main disadvantage is that usually the calculation time is very long. In case of evaluation of yearly time series, one run can be several hours long on a new PC. This may limit the use of simulators in the preliminary design phase, where the screening of a range of available process options and operational parameters may involve a large number of runs.

Another aspect that must be noted concerning dynamic biological models, is that their complexity leads to the introduction of considerable uncertainties (Reichert and Vanrolleghem, 2001). Such uncertainties are usually taken into account by means of Monte Carlo simulations (Saltelli *et al.*, 2005), which imply a large number of simulations. An approach to handle such uncertainties has been undertaken by building a risk assessment tool based on the WEST simulator (Rousseau *et al.*, 2001; Bixio *et al.*, 2002a), which has strongly inspired the work of this Ph.D. dissertation. A similar approach was adopted by Neumann *et al.* (2005).

A particular case of “design” is the upgrade of an existing plant (plant extension, process optimisation, real-time control). For this application, the use of dynamic models is already largely diffused both in academia and industry. Some examples are mentioned in Gernaey *et al.* (2004b) and other recent interesting ones are the work of Bixio *et al.* (2004), Jobbágy *et al.* (2004), Kroiss *et al.* (2004).

These studies are characterised by model-based tests of pre-defined upgrade options, usually only one and in some cases two or three options are compared. Due to the long calculation time, only a few alternatives of design/operational parameter values (volumes, recycle rates, controller

set-points, etc.) are evaluated, so that that the optimisation of the process relies substantially on the expert performing the study.

### 3.1.4 RIVER WATER QUALITY

During the 1980s and 1990s the standard model in water quality was QUAL2E (Brown and Barnwell 1987; Shanahan *et al.*, 1998). QUAL2E is an example of a multiconstituent river ecosystem model. This model is able to predict a variety of water quality constituents including conservative substances, algal biomass and Chlorophyll-a, ammonia, nitrite, nitrate, phosphorus, carbonaceous BOD, sediment oxygen demand, dissolved oxygen, coliforms and radionuclides. Shanahan *et al.* (1998) point toward problems with the use of QUAL2E, like non-closed mass balances.

In order to overcome some of the problems with QUAL2E, a new model has recently been developed, the River Water Quality Model No.1 (RWQM1) (Reichert *et al.*, 2001). The main goal of this effort, however, was to formulate a suite of standardised, consistent river water quality models and guidelines for their use. Moreover, RWQM1 was aimed to be compatible with the existing ASM models since they are both COD-based models. RWQM1 introduced bacterial biomass as a component. In this way, bacterial concentration can vary in time, allowing a better description of the observed water quality changes without modifications of the parameters. It also introduces some new processes that were not included in QUAL2E like pH equilibrium reactions, precipitation and predation processes. No anaerobic processes are included in the general model structure. RWQM1 is designed to have closed mass and elemental balances. For every organic component a fixed composition is given, described by the mass fractions  $\alpha^C$  (carbon),  $\alpha^H$  (hydrogen),  $\alpha^O$  (oxygen),  $\alpha^N$  (nitrogen),  $\alpha^P$  (phosphorus) and  $\alpha^X$  (all the other elements), which moreover sum to one. With the aid of the chemical oxidation reaction and a choice of a reference compound for every element considered, the COD of each form of organic matter can be determined. For all reactions the ionic charge balance is closed as well.

### 3.1.5 MODEL INTEGRATION

One of the main problems when developing an integrated model is the incompatibility between state variables, processes and parameters used in the different sub-models. An example of the difference between state variables is given by the treatment plant model and the river model, the former being typically based on COD and the latter on BOD, like QUAL2E. Maryns and Bauwens (1997) tried to avoid the problem by using the ASM1 model in riverine conditions but this approach did not give satisfactory results. To tackle this problem more fundamentally, the IWA (International Water Association) task group on river water quality has developed a new COD based model, RWQM1. The states of this model are more like the ASM states, but some differences still remain. This is due to the fact that the full RWQM1 model has to describe more components than the ASM1 model (e.g. algae growth).

The environmental conditions in the sub-systems being rather different, the main processes will also differ due to the fact that the same group of organisms behaves differently depending on the environment. For instance, nitrifying bacteria in an activated sludge system are confronted with a high competition for oxygen due to the presence of heterotrophic organisms in high concentrations, while in the river system this competition is not that strong.

Therefore, when using two models with different state variables, a connector needs to be

developed in order to ‘translate’ the state variables of the original model to the state variables of the destination model in a consistent way. This connector needs to contain all available knowledge about the different states in the two models, different environmental conditions in origin and destination and requires closed elemental balances; in most cases the considered elements are C, N, P, O and H. This elemental balancing feature is one of the basic principles in all types of models and it is hence important to adhere to these principles. This can also be seen from the evolution of activated sludge models, where ASM2 and ASM3 models (Henze *et al.*, 2000) have closed elemental mass balances as well. Unlike a few years ago, when all in-sewer process models were BOD-based (Fronteau *et al.*, 1997), recent models for this sub-system follow the same tendency and are COD-based as well, which makes integration and connection of models for the urban wastewater system easier (Huisman *et al.*, 2003; Mourato *et al.*, 2003).

A few approaches to link models can be found in literature. One example applied to connect ASM1 to an anaerobic digestion model was presented by Copp *et al.* (2003). Their primary aim was to maximise the flux into some components with respect to the total COD and nitrogen contents. Another solution is to adapt and extend the individual models to create a “supermodel” that includes all state variables of all submodels (Jones and Takacs, 2004). However, this is often not desirable because it increases model complexity as the behaviour of all state variables must be described in each subsystem and it results in the addition of unused state variables to submodels.

More recently, a systematisation and refinement of the approach in connecting models has been developed (Vanrolleghem *et al.*, 2005b), which allows the use of a general methodology to consistently connect any model expressed with the Petersen matrix format and to solve some problems affecting the above described method, like negative outputs. This approach is referred to as the continuity-based interfacing method (CBIM) and examples of its application can be found in Zaher *et al.* (2007) and in Volke *et al.* (2006).

The CBIM approach has been adopted in this work and it is explained in Chapter 10 by means of the description of the connector developed and used in this study.

## 3.2 Software

### 3.2.1 INTEGRATED CATCHMENT SIMULATOR

The Danish Hydraulic Institute (DHI) and the Water Research Centre (WRC) in the UK developed an “Integrated Catchment Simulator (ICS)” (Clifforde *et al.*, 1999; Taylor *et al.*, 2000) linking together widely known commercial tools (MOUSE for sewers, STOAT for treatment plants and MIKE11 for rivers) both in a sequential and in a simultaneous way. The ICS had the following functional requirements:

- a strong graphical capacity of the user interface to provide a user-friendly working environment, including the visualisation of the modelled catchment, individual models and the model interaction points;
- the model integration to be done intuitively through the user’s response to simple dialogues and graphics, i.e. without the need for an in-depth understanding of the underlying data processing techniques and transfer of flow and pollution components between different models;

- the system to be capable of sequential and simultaneous simulations, in order to cover the full range of applications, including hydraulic and real-time control (RTC) feedback in the upstream direction;
- the system to allow integrated modelling at various scales (i.e. levels of detail), in order to match actual study requirements;
- the system to be as open as possible, in order to enable the integration of various models within the same generic framework.

### 3.2.2 OPENMI

OpenMI ([www.openmi.org](http://www.openmi.org)) stands for Open Modelling Interface and is the product of the EU HarmonIT project ([www.harmonit.org](http://www.harmonit.org)). The key requirements of the OpenMI are to:

- link models from different domains (hydraulics, hydrology, ecology, water quality, economics etc.) and environments (atmospheric, freshwater, marine, terrestrial, urban, rural etc.)
- link models based on different modelling concepts (deterministic, stochastic etc.)
- link models of different dimensionality (0, 1, 2, 3D)
- link models working at different scales (e.g. a regional climate model to a catchment runoff model)
- link models operating at different temporal resolutions (e.g. hourly to monthly or even annual)
- link models operating with different spatial representations (e.g. networks, grids, polygons)
- link models using different projections, units and categorizations
- link models to other data sources (e.g. databases, user interfaces, instruments)
- link new and existing (legacy) models with the minimum of re-engineering and without requiring unreasonably high level IT skills
- not impair performance, especially of large models
- be based on proven and available technologies (and, in particular, the architecture must be component-based and multi-layered)
- link models running on different platforms (e.g. Windows, Unix and Linux)
- be 'open' (the interface specification should be placed in the public domain)
- allow components to be developed using at least the following programming languages: C/C++, C#, Fortran, Delphi/Pascal, Java and Visual Basic.

The OpenMI defines a standard interface that has three functions:

- **Model definition:** To allow other linkable components to find out what items this model can exchange in terms of quantities simulated and the locations at which the quantities are simulated.
- **Configuration:** To define what will be exchanged when two models have been linked for a specific purpose.

- Runtime operation: To enable the model to accept or provide data at run time.

### 3.2.3 REBEKA

REBEKA is a recent software tool described by (Rauch *et al.*, 2002b) that uses simplified models to describe the effect of the urban drainage system on alpine rivers. It can be used to predict both hydraulic stress (erosion) and acute water pollution (high concentration of ammonia).

### 3.2.4 SIMBA

Another platform created to simulate integrated models which is based on commercial existing tools is SIMBA (Alex *et al.*, 1999). This software package uses the widely used Matlab/Simulink™ tools to allow for simultaneous simulations. It can be seen as a network of interlinked elements that are computed at the same time:

- PLASKI for the urban catchment;
- SIMBA SEWER for the sewer system quantity and quality;
- SIMBA for the WWTP;
- SIMBA SEWER is used for the simulation of the river system with an adapted conversion model;
- Simulink for the use of control items in any of the subsystems or across them.

### 3.2.5 SYNOPSIS

Schütze *et al.* (1999; 2002) carried out the assembly and the implementation of the integrated simulation and optimisation tool SYNOPSIS. The authors created an integrated model in which:

- the sewer system was modelled as a reservoir cascade and assumed complete mixing of pollutants. It consists of the software package EWSIM, which is an extended version of the commercial KOSIM package;
- the biological treatment was based on the model of (Lessard and Beck, 1991);
- the river quality model mainly encompassed dissolved oxygen and organic matter (expressed in terms of BOD) in two fractions (slowly and readily biodegradable matter). The water quality was simulated using DUFLOW (Aalderink *et al.*, 1995).

### 3.2.6 WEST

WEST (World-wide Engine for Simulation, Training and automation) is a multi-platform modelling and experimentation system (Vanhooren *et al.*, 2003). It allows one to construct models and conduct virtual experiments on any kind of system that can be represented by differential algebraic equations. The WEST simulator was originally used mainly for simulation of wastewater treatment plants and an extensive WWTP modelbase is available (Vanhooren *et al.*, 2003). The model base plays a central role in WEST. In this model base, models are described in a high level object-oriented declarative language specifically developed to incorporate models. The modelbase

is aimed at maximal reuse of existing knowledge and is therefore structured hierarchically. This indicates that WEST has an open structure in that the user is allowed to change existing models and define new ones as needed. Next to the ASM models, a runoff/sewer model based on KOSIM (Solvi *et al.*, 2005) and the RWQM1 are now implemented in this package and run in simultaneous simulations mode e.g. for integrated RTC investigations (Meirlaen *et al.*, 2001).

### 3.3 Problems in integrated modelling

The real-life application of such models and software encounters several problems due to their complexity. First of all, it is very difficult to obtain the data required to calibrate models with a large number of parameters. The inputs to these models are very uncertain because of the difficulty and price of collecting the data, the extensive periods needed to cover seasonal variability and the scattered responsibilities in collecting the data.

Another issue is the large number of equations involved, which makes simulations of integrated models very time consuming. This can be caused also by the fact that the many different time-scales of the modelled process make the model stiff, therefore slower to be integrated with most of the numerical solvers.

On top of that, the already heavy calculation burden increases by several orders of magnitude in the case of uncertainty assessment performed by means of Monte Carlo simulation.

The software WEST was chosen to perform this study since it is the one that minimises the above mentioned problems, allowing fast simulation, model integration in one single platform and possibility to run Monte Carlo simulations with the aid of distributed computing.

### 3.4 Conclusions

Many years of experience in modelling the components of the urban wastewater system – with a consistent increase of development and use in the last decade, due to the advent of more and more powerful personal computers – makes a wide library of models available to be applied. Due to the intrinsically time-varying behaviours, particular attention was devoted to develop dynamic mechanistic models, implemented in a number of software platforms.

More recently, particular attention was given to the integration of such models to be able to model the whole urban wastewater system, in order to understand and predict the interactions between the sub-systems. Several software tools were used or developed to allow the use of this approach. Nevertheless, not many applications on real cases have been published so far.

Several problems are implicit in integrated modelling, like large and stiff models, and many input parameters. The use of the software WEST allowed in this study to overcome most of such problems.





## **PART B**

### **WHERE TO IMPROVE THE UWWS**



## CASE STUDY - THE NETE RIVER BASIN

In this chapter, the Nete river basin – used to illustrate the proposed methodology with a case study – is characterised and the data collected for the analysis are described.

### 4.1 Description

The methodology used implies as a first indispensable step a comprehensive collection of data and general information from wastewater operators, environmental agencies and authorities. The Nete river basin in Flanders (Belgium) was chosen as case study. This basin is named after its main river, a tributary of the Schelde and it is composed of 29 sewer catchments.

The aim of the illustrative case study was to give an example of systems analysis in a basin with fairly good river water quality and also to take advantage of the fact that this basin is the one with the largest water quality data set available in Flanders, Belgium. The systems analysis is formed by the analysis of all single municipal sewer catchments constituting the basin on a yearly time scale and includes the description of the main sewers (collectors) and WWTPs and their performance in environmental and economical terms.

The Nete river basin, located in the eastern part of Flanders (Belgium) was chosen for systems analysis since it is the basin with most available data in Flanders, due to specific studies regularly performed by VMM (the Flemish Environmental Agency) (VMM, 2001). The Nete basin comprises the Kleine Nete, the Grote Nete and their tributaries which, after merging, form the Beneden-Nete (Lower-Nete) (see figure 2.1). In the North, the area is bordered by the river basin of the Maas, to the East by the Dutch border and the river basin of the Maas, to the South by the basins of the Demer and the Dijle and Zenne and to the West by the basin of the Beneden-Schelde. The total surface area of the Nete basin is 1,673 km<sup>2</sup>.

Hydrographically, the Kleine Nete rises in the North of the municipality of Mol, on the Southern

incline of the Campine microcuesta. Downstream, the main tributaries are the Wamp, the Aa and the Molenbeek-Bollaak. The Grote Nete rises at the Southwest slope of the Campine High Plateau and flows through the sandy lowland plain in a more or less South-West direction. The Grote Nete receives the Mol Nete, the Wimp and the Grote Laak as main tributary watercourses. In Lier, the Kleine and Grote Nete join to form the Beneden-Nete, which drains water into the Schelde via the Rupel. The main tributaries of the Beneden-Nete are the Itterbeek and the Lachenebeek.

Administratively, the river basin is located entirely within the Flemish Region (see Figure 9). It is almost completely situated in the province of Antwerp. However, the upper course of the Grote Nete rises in the province of Limburg and the most Southern branches of the watercourse network go beyond the border with the province of Flemish Brabant.

The topography of the basin is definitively flat, as most of Flanders. The basin is characterised by the presence of extensive agriculture and farming and scattered urbanisation with some small towns (see Figure 9).

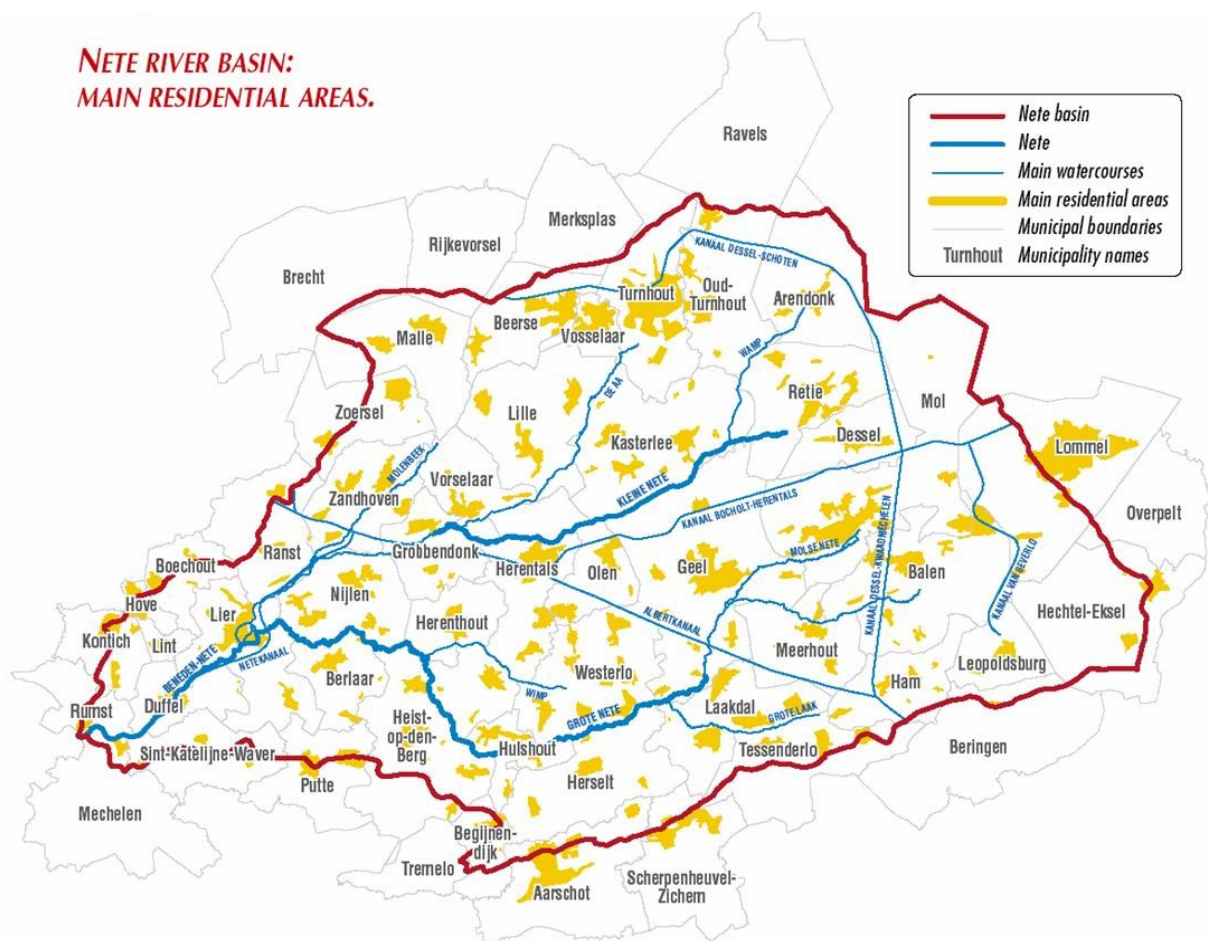

Figure 5: Nete river basin, administrative division and main residential areas.

Key figures of the Nete basin are:

- surface area within Flanders: 1,673 km<sup>2</sup>
- provinces: Antwerp, Limburg and Flemish Brabant
- municipalities: 54 (27 entirely and 27 partially)

- total length of water courses: 2,224 km
- total length of Grote and Kleine Nete: 151 km
- number of inhabitants: 595,823
- number of companies sampled: 83
- number of companies: 4,121
- number of water column measuring sites: 377
- number of water bottom measuring sites: 30
- number of existing WWTPs: 29

The Flemish principal wastewater infrastructure (WWTPs and trunk sewers) is operated by Aquafin, which was founded by the Flemish Government in 1990 as the licence holder for the sewage treatment infrastructure in Flanders. All other conduits are owned and operated by municipalities or other governing bodies such as the Belgian Railway company, private institutions (e.g. hospitals), Provinces, etc.

Substance flows and indicators were calculated on a yearly basis for the year 2002, which was a rather wet year in Flanders (1006mm, while the average precipitation is around 750mm/year) but did not lead to any flooding or malfunctioning of technical infrastructures. The substances selected to be used for the calculation of substance flows and indicators were water, BOD, COD, TN, TP and Zn.

## 4.2 Data collection

### 4.2.1 METEOROLOGICAL DATA

Rainfall data were acquired from the Belgian Royal Meteorological Institute (KMI). They consist of monthly rainfall recorded at the 11 stations present in the Nete basin. A summary of the data is presented in Figure 6.

For this study, no spacial nor temporal variation was considered. The monthly average rainfall on the whole basin has been used for all municipal sewer catchments, since no sophisticated hydrological tools were used, given the rather small standard deviation and the long time scale of the study (yearly, no detailed rainfall dynamics were needed).

### 4.2.2 HOUSEHOLDS' DATA

Data regarding households have been obtained from VMM and they consist in inhabitants living and inhabitants discharging in all residential areas in which municipalities are subdivided. These data are from year 2001, but are considered valid also for year 2002, since it was assumed that no significant changes occurred in the residents distribution in the Nete basin. It is to be noticed that a significant difference exists between the number of inhabitants connected to sewers (as provided by VMM) and the same figure resulting from the Aquafin database, the latter suggesting a higher percentage of connections. The daily movement of people from one catchment to another one was not considered, since it is mostly a rural area. Therefore, people are not expected to move during the day to a large industry or service centre.

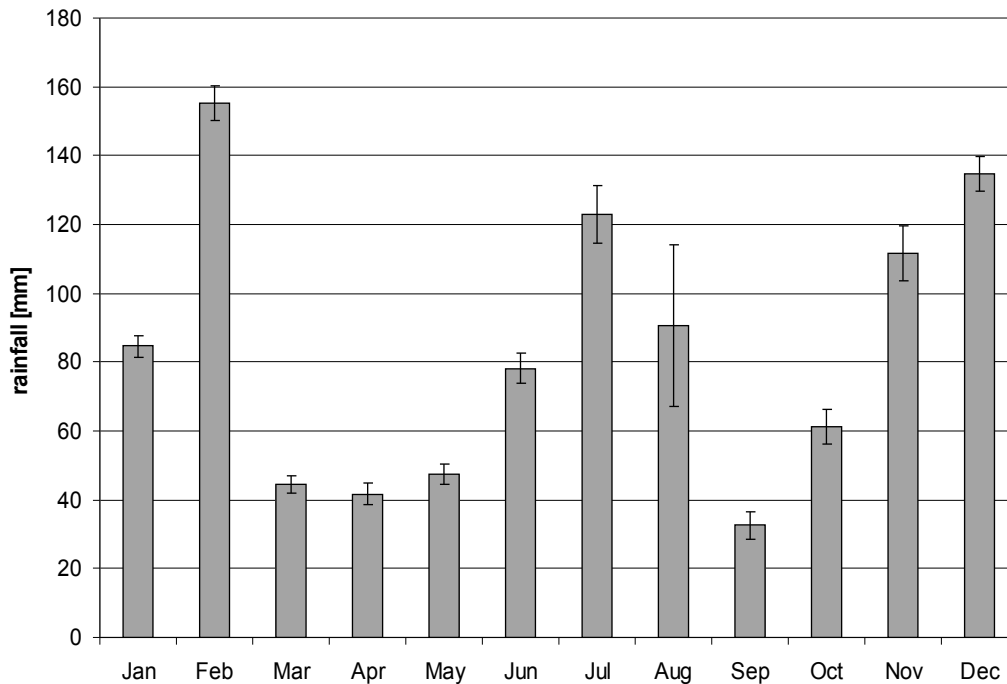

Figure 6: Average monthly rainfall data for the 11 stations in the Nete basin in year 2002; error bars show standard deviations.

In Table 3 an excerpt of the table containing data on households is displayed. Each row represents a residential area. Differences in inhabitants living and discharging for some residential areas are due to the connection of some households situated in one area to be discharging to the WWTP of another area. There are four categories of areas:

- **A:** all households are connected to a sewer collector and wastewater is conveyed to a WWTP; each municipality has a WWTP; therefore, if several A areas are present in a municipality, the number of inhabitants discharging in each of them is zero except in the one which hosts the WWTP.
- **B:** all households are connected to a sewer collector and wastewater is discharged in a water body, but the connection of the collector to a WWTP is already planned.
- **C:** all households are connected to a sewer collector and wastewater is discharged in a water body and the connection of the collector to a WWTP is not planned.
- **OW:** all households are discharging directly in a water body.

Table 3: Excerpt of households' data base.

Area	Inhabitants living	Inhabitants discharging	Municipality
151 A	59	0	Arendonk
151 A	7,872	7,931	Arendonk
151 OW	7	7	Arendonk
151 OW	94	94	Arendonk
151 OW	3,440	3,440	Arendonk
151 OW	119	119	Arendonk

In order to calculate the amount of water, BOD, COD, TN, TP and Zn released by households, the values in Table 4 have been assumed for production of substance per inhabitant per day. Such values have been found in the report of VMM (2001) and are valid for the whole Nete basin; they come from a measurement campaign performed in a sewer pipe collecting wastewater from a small residential catchment (around 100 people) in controlled conditions, therefore the values are considered to be measured at source. The values in Table 4 are well in the range of values presented in other studies (see Zessner and Lindtner, 2005).

Table 4: Production of substances per inhabitant per day, from VMM (2001).

Water	COD	BOD	TN	TP	Zn
112 L·inh <sup>-1</sup> ·d <sup>-1</sup>	94 g·inh <sup>-1</sup> ·d <sup>-1</sup>	44 g·inh <sup>-1</sup> ·d <sup>-1</sup>	10 g·inh <sup>-1</sup> ·d <sup>-1</sup>	1.7 g·inh <sup>-1</sup> ·d <sup>-1</sup>	30.7 mg·inh <sup>-1</sup> ·d <sup>-1</sup>

Households' loads have been obtained for all municipalities for the four categories of discharge destination (A, B, C and OW) multiplying the values in Table 4 by the number of inhabitants in each category in each municipality. Categories B and C have been lumped since the paths of discharge are exactly the same, for the time being.

For later calculations it has been assumed that no conversions take place in the sewer network (e.g. BOD removal). The fact that septic tanks are common in the Nete basin has been considered in some scenarios, by assuming some figures for their removal of BOD, COD and TP.

### 4.2.3 INDUSTRIES DATA

Data on industrial discharges have been obtained from VMM and are comprehensive of all monitored industries in the Nete basin until the year 2002. An excerpt of the table containing data on industrial discharges is shown in Table 5. The column "zone" refers to the category of discharge (A, B, C or OW).

Table 5: Excerpt of table containing data on industrial discharges.

Year	Name	Municipality	Zone	Discharging days	Q [m <sup>3</sup> /d]	BOD [kgO <sub>2</sub> /d]	COD [kgO <sub>2</sub> /d]	TN [kgN/d]	TP [kgP/d]	Zn [g/d]
1993	*****	HERENTALS	A	243	1,130	2	32	6	1	42
1994	*****	HERENTALS	A	230	1,752	6	69	5	1	76
1995	*****	HERENTALS	A	225	1,695	6	47	15	1	114
1996	*****	HERENTALS	A	230	448	4	11	5	0	7

Industrial loads have been obtained for all municipalities for the four categories of discharge destination (A, B, C and OW) summing the loads of all industries for water, BOD, COD, TN, TP and Zn in each category in each municipality. Categories B and C have been lumped since the paths of discharge are exactly the same.

It is important to note that data are available only for monitored major industries; no data are available for medium and small industries and for some major industries that were not monitored.

#### 4.2.4 AGRICULTURE DATA

For the study VMM provided data on manure use in the Nete basin for the year 2001. No significant changes are assumed to have occurred in the year 2002; therefore, these data were used in the analysis for the year 2002.

The nitrogen and phosphorus content of manure applied on land by farmers is available in kilograms per year for all hydrographic zones of the basin. Coefficients are available that estimate the percentage of applied nutrients that end up in the receiving water body (VMM, 2001):

- Nitrogen: 6.3%
- Phosphorus: 2.2%

Since the subdivision of the basin in hydrographic zones is not compatible with the subdivision in municipalities, these data were used only in the flow analysis of the whole basin and not for single municipalities.

#### 4.2.5 SEWER CATCHMENTS DATA

Aquafin provided data concerning the sewer catchments in all 29 municipalities discharging in the Nete basin. Each municipality has a WWTP to which the sewer system conveys the collected wastewater.

The following data were available for all catchments for the year 2002:

- drained surface area;
- catchment imperviousness;
- average surface slope;
- number of inhabitants connected;
- number of pumping stations;
- number of combined sewer overflows (CSOs);
- pumping energy;
- pumping cost;
- personnel cost;
- capital cost;
- other costs;
- length of pipes for different diameters classes;
- slope of pipes for different diameters classes;
- materials of pipes used.

Information common to all datasets in all catchments:

- no controlled variables;
- no on-line measurements;
- no off-line measurements;
- no chemicals used.

It is important to be able to interpret the size of catchments in Figure 7, which shows the length of pipes in the sewer networks for different diameter classes. These data are derived from the



available models of the different catchments, which do not include the whole catchments' areas. An estimation of the missing areas is reported in Figure 8.

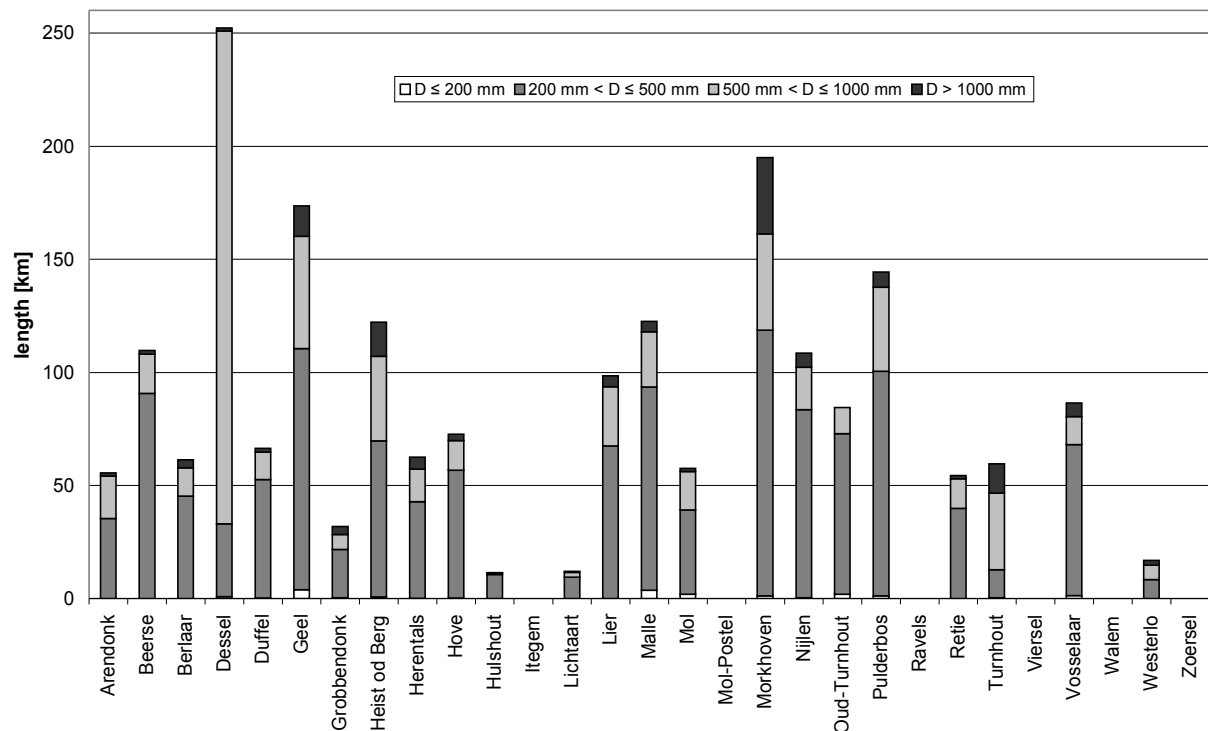

Figure 7: Length of pipes in sewer for classes of diameters; data from available Aquafin network models.

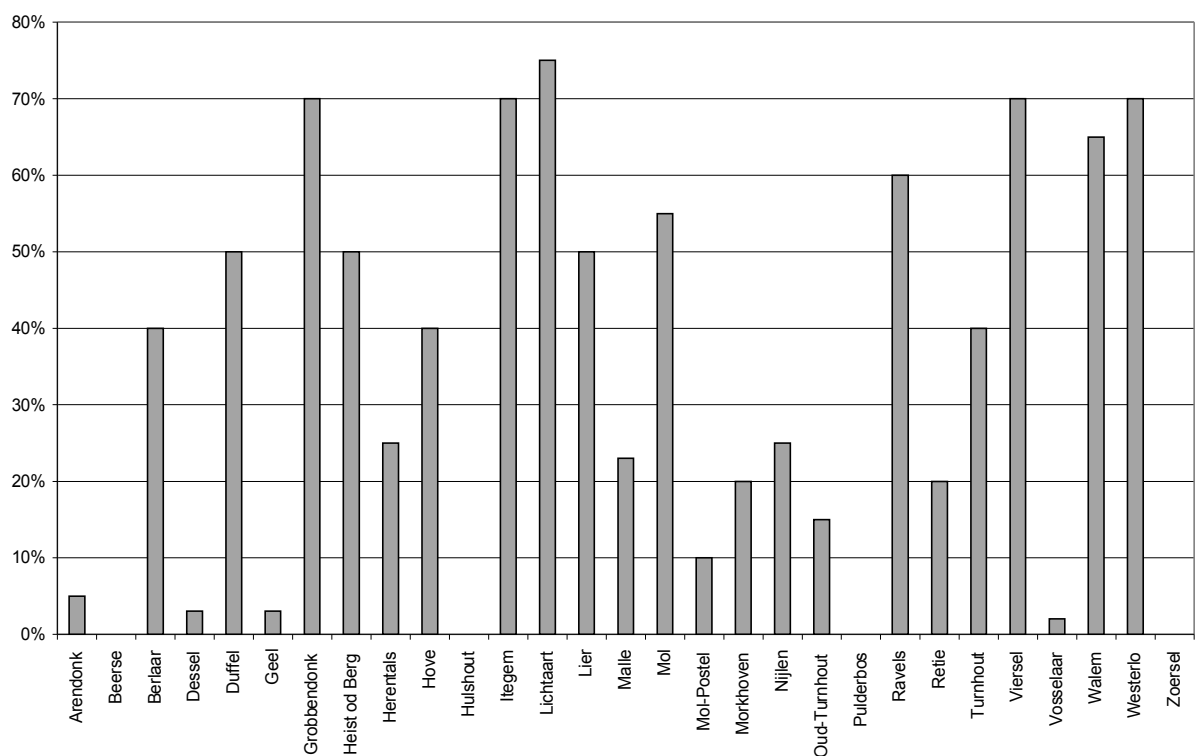

Figure 8: Percentage of catchment area not covered by Aquafin sewer network models.

#### 4.2.6 WWTPS DATA

Aquafin provided extensive datasets on all WWTPs in the Nete basin, which included the following information:

- year of construction;
- population equivalent;
- surface occupied;
- description of process type, with main volumes and surfaces;
- controlled variables;
- on-line measurements;
- off-line measurements;
- daily flow rates;
- sludge retention time (SRT), hydraulic retention time (HRT);
- process measurements (DO, MLSS, SVI);
- basic water quality measurements (COD, NH<sub>4</sub>, TKN, NO<sub>3</sub>, TN, TP, PO<sub>4</sub>), from VMM;
- heavy metals measurements (As, Cd, Cr, Cu, Hg, Ni, Pb, Zn), from VMM;
- chemicals used;
- sludge production quantity;
- heavy metals (As, Cd, Cr, Cu, Hg, Ni, Pb, Zn) in sludge, from VMM;
- type of sludge disposal;
- volume of incoming septic material;
- pumping and aeration energy;
- pumping and aeration cost;
- sludge disposal cost;
- dewatering cost;
- chemical cost;
- personnel cost;
- capital cost;
- other costs.

Table 6 and Figure 9 to Figure 14 include the information available to describe the 29 WWTPs present in the Nete basin. It is apparent that in the range of small to medium plant size (<100,000PE) several types of plants are present, with rather different characteristics. In some graphs, values corresponding to small-scale WWTPs are omitted since not reliable.

Table 6: Processes and dimensions of WWTPs.

WWTP	Process and volumes
Arendonk	Low loaded oxidation ditch (3,700m <sup>3</sup> ) + 2 secondary clarifiers (2 x 490m <sup>2</sup> )
Beerse	2 lanes after primary clarifier (362m <sup>2</sup> ): [1] pre-denitrification system (anoxic tank (300m <sup>3</sup> ) + aeration tank (2 x 280m <sup>3</sup> ) + secondary clarifier (881m <sup>2</sup> )); [2] 2 trickling filters (2 x 750m <sup>3</sup> ) to aeration tank of lane [1]
Berlaar	Low loaded oxidation ditch (3,200m <sup>3</sup> ) + 2 secondary clarifiers (2 x 1,210m <sup>2</sup> )
Dessel	Pre-denitrification system (anoxic tank: 700m <sup>3</sup> + Lubecker tank: 400m <sup>3</sup> ) + 1 secondary clarifier (314m <sup>2</sup> )
Duffel	2 primary clarifiers (2 x 314m <sup>2</sup> ) + 3 trickling beds (3 x 950m <sup>3</sup> ) + 1 secondary clarifier (314m <sup>2</sup> )
Geel	Pre-denitrification tank (1,740m <sup>3</sup> ) + oxidation ditch (8,600m <sup>3</sup> ) + 3 secondary clarifiers (3 x 598m <sup>2</sup> )
Grobbendonk	Low loaded oxidation ditch (1,200m <sup>3</sup> ) + 1 secondary clarifier (653m <sup>2</sup> )
Heist op den Berg	Low loaded oxidation ditch (3,300m <sup>3</sup> ) + 2 secondary clarifiers (2 x 491m <sup>2</sup> )
Herentals	Low loaded activated sludge (5,170m <sup>3</sup> ) + 1 secondary clarifier (1,385m <sup>2</sup> )
Hove	2 Primary clarifiers (2 x 205m <sup>2</sup> ) + activated sludge tank (2,500m <sup>3</sup> ) + 2 secondary clarifiers (2 x 531m <sup>2</sup> )
Hulshout	Activated sludge (150m <sup>3</sup> ) + 2 secondary clarifiers (Dortmund tanks) (2 x 27m <sup>2</sup> )
Itegem	Imhoff tank (81m <sup>2</sup> ) + trickling filter (672m <sup>3</sup> ) + 2 secondary clarifiers (2 x 38m <sup>2</sup> )
Lichtaart	Primary clarifier (1,075m <sup>2</sup> ) + trickling filter (1,159m <sup>3</sup> ) + intermediate clarifier (1,075m <sup>2</sup> ) + plug flow (1,752m <sup>3</sup> ) + 2 secondary clarifiers (2 x 908m <sup>2</sup> )
Lier	Low loaded oxidation ditch (9,600m <sup>3</sup> ) + 3 secondary clarifiers (707m <sup>2</sup> )
Malle	Activated sludge (1,052m <sup>3</sup> ) + secondary clarifier (350m <sup>2</sup> )
Mol	2 lanes: [1] oxidation ditch with pre-denitrification (2 x 570m <sup>3</sup> ) + secondary clarifier (908m <sup>2</sup> ); [2] primary clarifier (227m <sup>2</sup> ) + 2 trickling filters (2 x 1,317 m <sup>3</sup> ) to line [1]
Mol-Postel	Two-stage reed bed (step 1: 600m <sup>2</sup> ; step 2: 300m <sup>2</sup> ) with primary clarifier (20m <sup>2</sup> )
Morkhoven	2 lanes: [1-households]: primary clarifier (480m <sup>2</sup> ) + plug flow (5,850m <sup>3</sup> ) + secondary clarifier (480m <sup>2</sup> ); [2-industry]: primary clarifier (480m <sup>2</sup> ) + trickling filter (1,820m <sup>3</sup> ) + secondary clarifier (480m <sup>2</sup> )
Nijlen	2 primary clarifiers (2 x 151,5m <sup>2</sup> ) + 4 trickling filters (4 x 628m <sup>3</sup> ) + 2 secondary clarifiers (2 x 100m <sup>2</sup> )
Oud-Turnhout	Low loaded oxidation ditch (2,700m <sup>3</sup> ) + 2 secondary clarifiers (2 x 314m <sup>2</sup> )
Pulderbos	2 Low loaded oxidation ditches (1,745m <sup>3</sup> ) + 1 secondary clarifier (512m <sup>2</sup> )
Ravels	Activated sludge (2x1,350m <sup>3</sup> ) + secondary clarifier (314m <sup>2</sup> )
Retie	2 Oxidation ditches (2 x 1,250m <sup>3</sup> ) + 1 secondary clarifier (380m <sup>2</sup> )
Turnhout	1 primary clarifier (854m <sup>2</sup> ) + 2 low loaded oxidation ditches (9,000m <sup>3</sup> ) + 3 secondary clarifiers (3 x 972m <sup>2</sup> )
Viersel	Aerated lagoon (850 + 562m <sup>3</sup> ) + secondary clarifier (pond) (920m <sup>2</sup> )
Vosselaar	Low loaded oxidation ditch (860m <sup>3</sup> ) + 1 secondary clarifier (314m <sup>2</sup> )
Walem	2 Imhoff tanks (2 x 63m <sup>2</sup> ) + trickling filter (320m <sup>3</sup> ) + 1 secondary clarifier (Dortmund tank) (38m <sup>2</sup> )
Westerlo	Primary clarifier (866m <sup>2</sup> ) + trickling filter (2,428m <sup>3</sup> ) + intermediate clarifier (866m <sup>2</sup> ) + plug flow (2,500m <sup>3</sup> ) + 2 secondary clarifiers (2 x 866m <sup>2</sup> )
Zoersel	Activated sludge (aeration tank) (28m <sup>3</sup> ) + 2 secondary clarifiers (Dortmund tanks) (10m <sup>2</sup> )

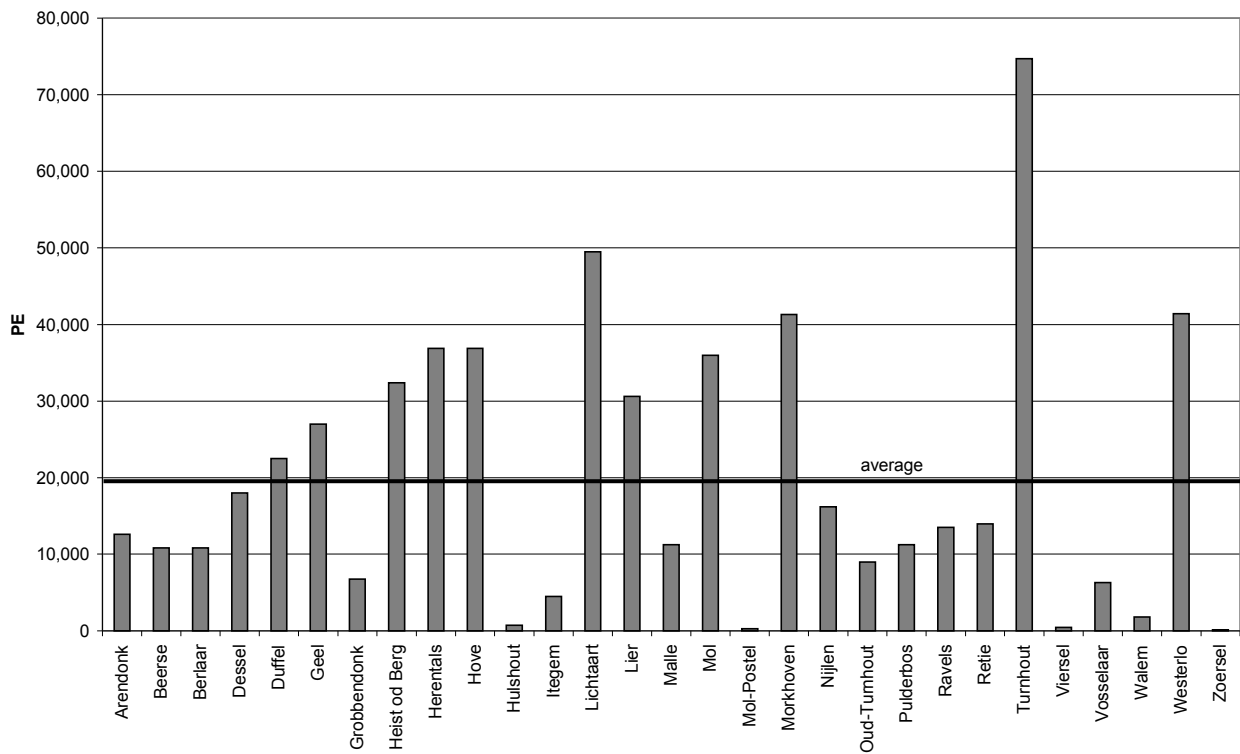

Figure 9: Design PE of WWTPs, on the basis of 54 gBODinh<sup>-1</sup>d<sup>-1</sup>.

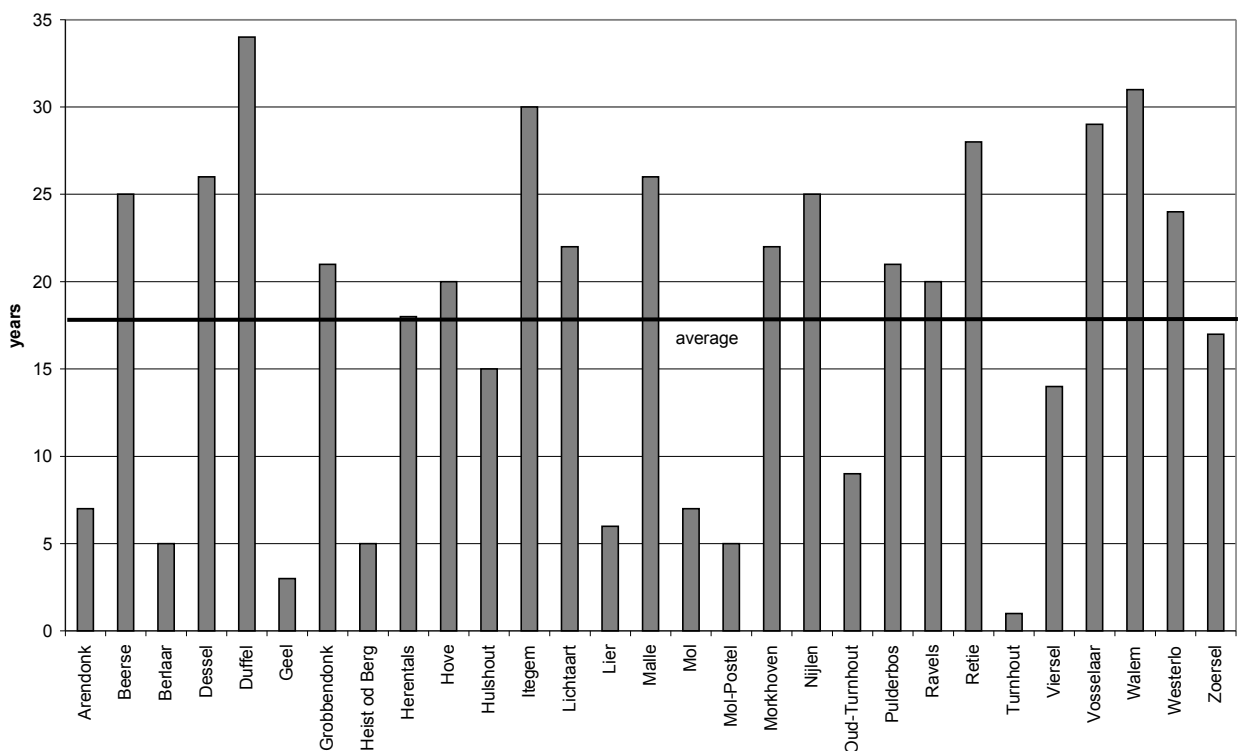

Figure 10: Age of WWTPs; based on the year of last renovation.

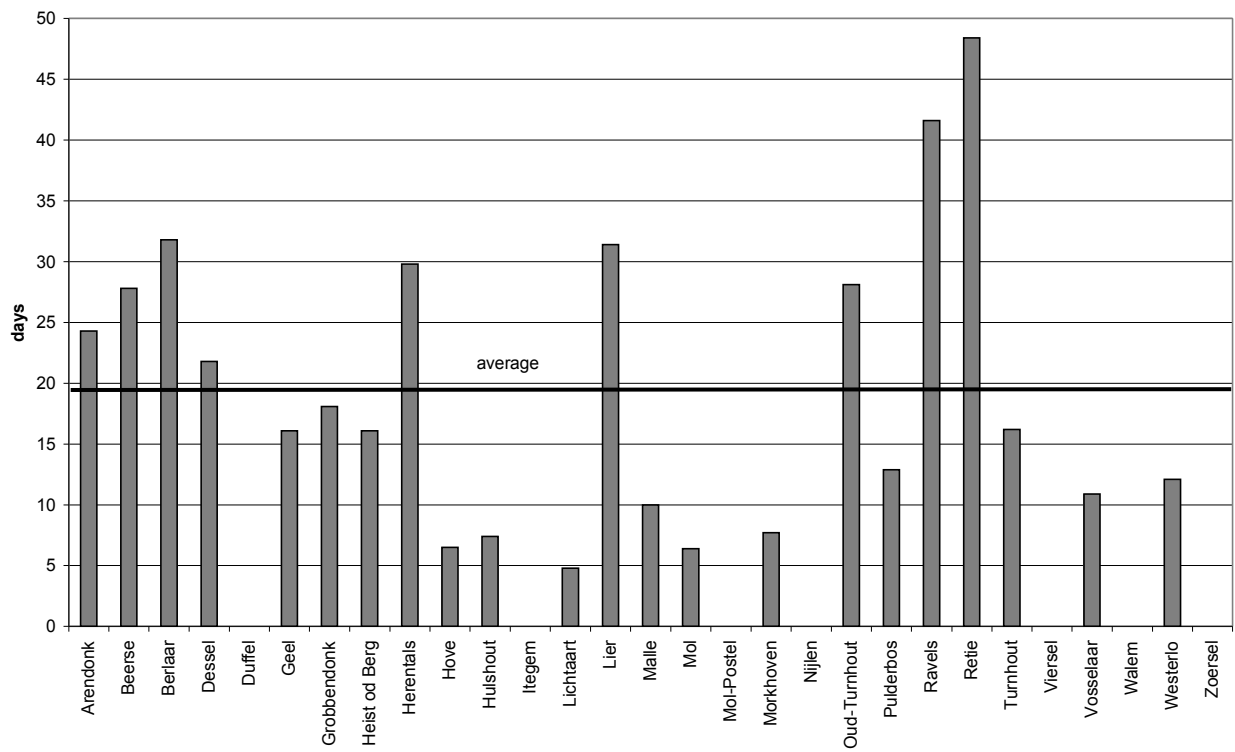

Figure 11: SRT of WWTPs.

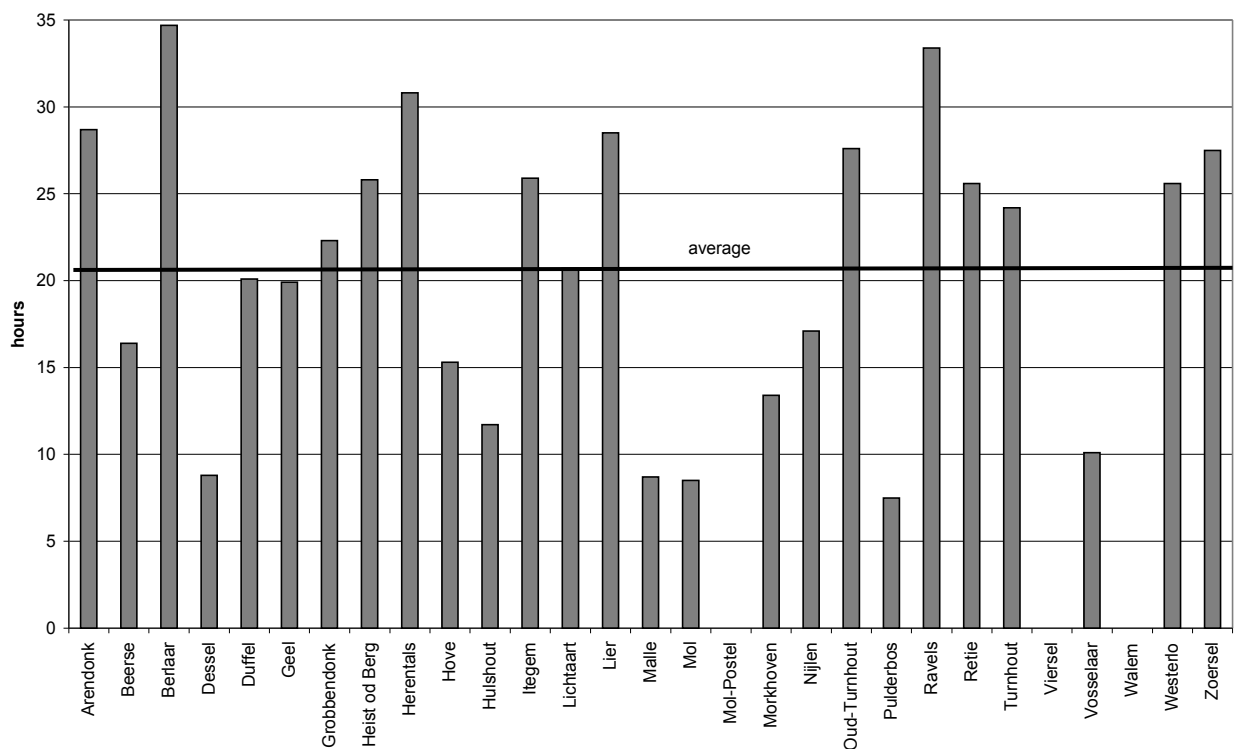

Figure 12: HRT of WWTPs.

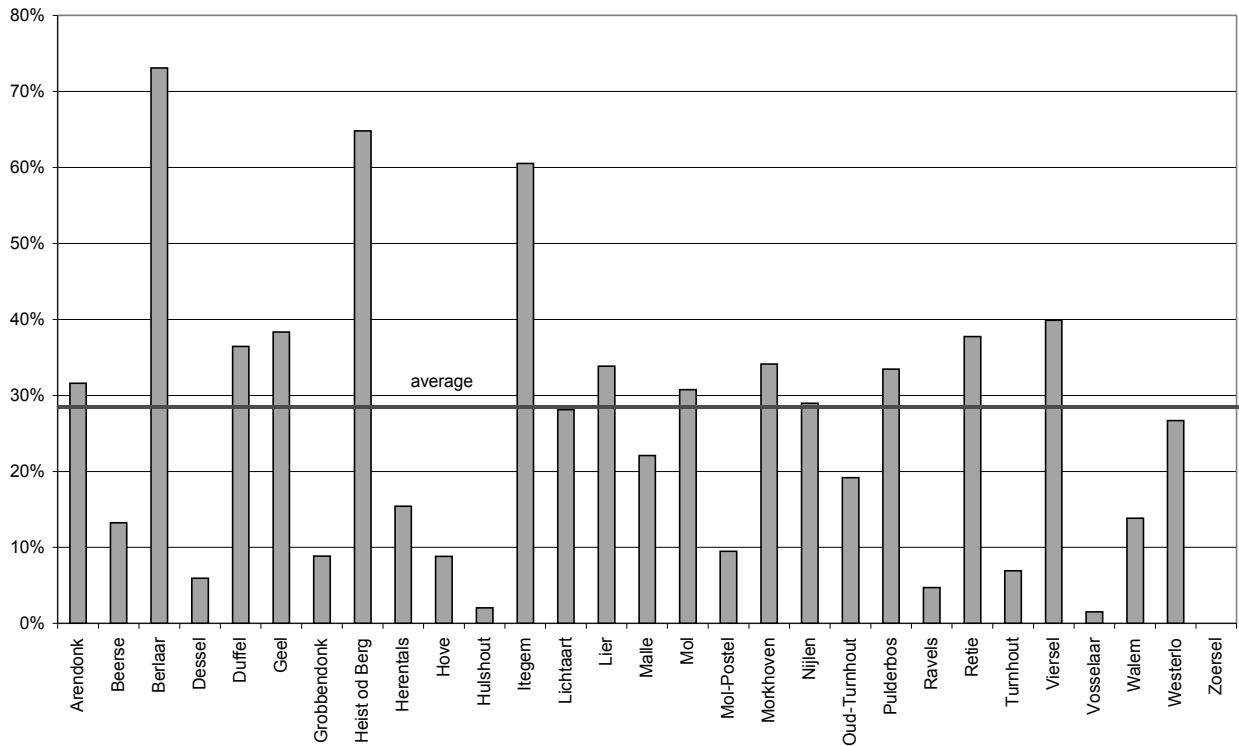

Figure 13: Fraction of inhabitants not connected to WWTPs.

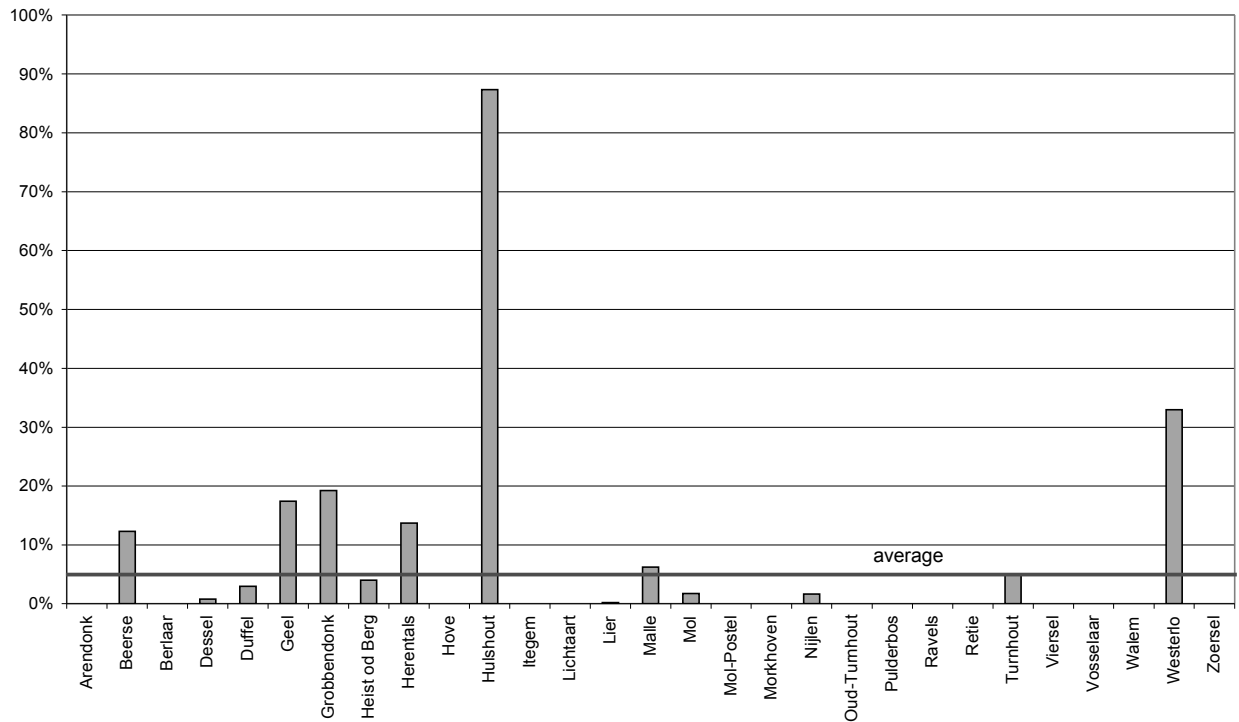

Figure 14: Fraction of industrial water entering WWTPs.

#### 4.2.7 RECEIVING WATER DATA

Concerning the river Nete, VMM provided values of the Prati index for oxygen (PPI) – based on the percentage of oxygen at saturation (Prati *et al.*, 1971) – and the Belgian biotic index (BBI) – based on macroinvertebrates (De Pauw and Vanhooren, 1983) – for year 2002 for 377 measurement stations.

AMINAL (Flanders' Environment, Nature, Land and Water Management Administration) provided hydraulic data regarding the Nete river and its tributaries for the year 2002 for the 9 existing measurement stations. Because of the incompatibility between the location of the measurement stations and municipality boundaries, only data from the closing section of the river basin has been used for the water flow analysis of the whole Nete basin.

### 4.3 Conclusions

The data used to perform the systems analysis of the Nete river basin was presented in this chapter. All the collected data for the year 2002 were presented, concerning the possible sub-systems interacting within the river basin and directly affecting the urban wastewater system (sewer, WWTP, river).





## SUBSTANCE FLOW ANALYSIS

*Parts of this chapter have been published as:*

**Benedetti, L., Dirckx, G., Bixio, D., Thoeye, C. and Vanrolleghem, P.A. (2006) Substance flow analysis of the wastewater collection and treatment systems. *Urban Water Journal* 3(1), 33-42.**

The first step in the systems analysis of the river basin is the substance flow analysis (SFA) of the whole basin, eventually followed by the SFA of urban catchments (see Figure 15).

### 5.1 Method

The development of a substance flow analysis basically comprises:

- a. problem definition: definition of goals, selection of substances and processes to be included, definition of system boundaries and choice of time span to be considered, choice of indicators and evaluation instruments;
- b. calculation of mass fluxes of substances;
- c. analysis of uncertainty.

The term “process” denotes the transport, transformation or storage of substances. While in most cases transport does not change the chemical composition of substances, it requires energy and involves other substances. The same applies to storage.

Through transformation, substances are changed into new substances with new qualities and usually new chemical composition. In systems analysis it is convenient to link substances and processes. Each substance has at least one origin and one destination process. Consequently, each process is linked to other processes by means of substances.

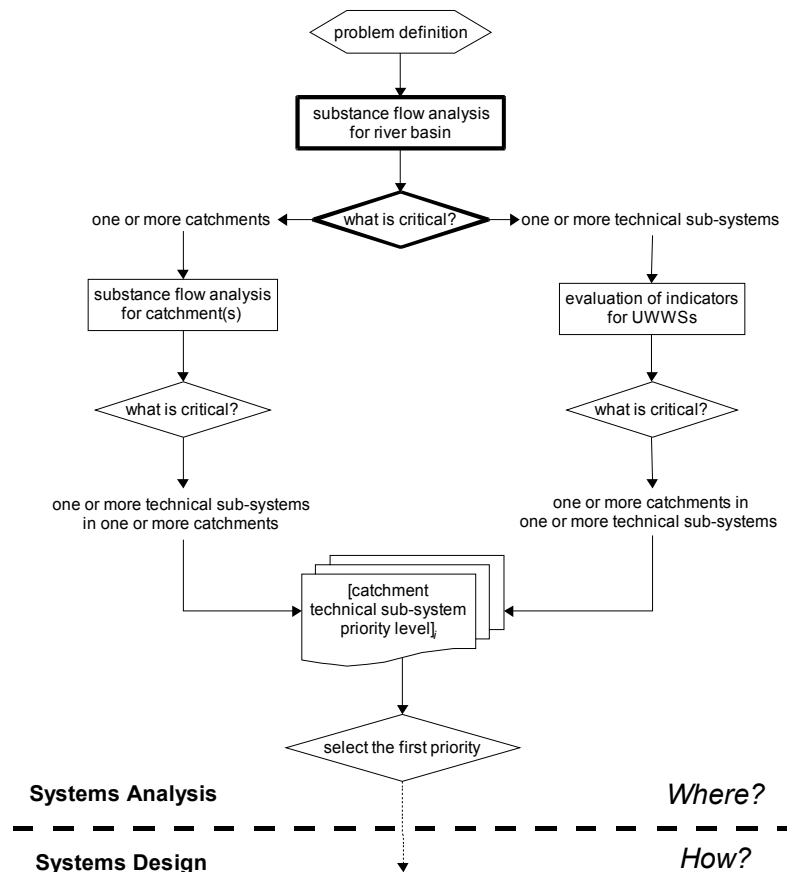

Figure 15: Substance flow analysis within Systems Analysis.

## 5.2 Problem definition

The focus of this study was on identification of critical paths of pollution, evaluation of indicators for energy consumption, for operational and investment costs and for environmental performance.

Another objective was to recognize the information gaps in the system owed to the typical methods of collecting data in the urban catchment.

In this SFA, an attempt was made to close the balances and track the movements of water, BOD, COD, TN, TP and Zn, which were also used to derive most of the indicators analysed in Chapter 6:

- **Water** was selected since the analysis of its flows can reveal problems like infiltration, exfiltration, WWTP overload, hydraulic stress to receiving water body.
- **BOD** and **COD** indicate organic pollution leading to oxygen depletion and CO<sub>2</sub> emission.
- **TN** and **TP** reveal eutrophication potential in the receiving water.
- **Zn** is the most detectable heavy metal (therefore measurements are fairly reliable) and is representative of toxic contamination.

The processes included are presented in Table 7 (see also Figure 16). For the rationale of the

system boundaries definition, see the next paragraph.

Within the wide set of components being part of the water cycle or interacting with it, only elements concerning the urban wastewater system were taken into account. Among this sub-set, the studied processes were the ones related to technical structures on which a water utility can act to improve the receiving water quality, including the receiving water itself.

As shown in Figure 16, all possible interactions were considered for the processes included in this systems analysis. In this study the other compartments were assumed to be flux sources or sinks, so only the interactions with processes in the system were taken into account. These source/sink compartments are described in Table 8 and were considered as boundary conditions.

The water supply system was excluded from the study since the concerning information needed (quantity of water used and entering the wastewater system) is contained in the information associated to water consumers, i.e. households and industry.

Within the scope of the Ph.D. work, sludge is only considered as a boundary condition for the wastewater system. This means that no technical details about sludge treatment and its interaction with the wastewater system are considered, but only the costs associated to the treatment and disposal of the amount of waste sludge produced by the WWTP.

Data were evaluated on a yearly time basis. Systems dynamics are not considered in this study, only average performances.

*Table 7: Processes included in the present study.*

Process	Description
Source control device	It is any device that intercepts rain water and recharges the groundwater, or separates household contributions and reroutes them.
Storm sewer	Pipes network that conveys rainwater; in combined sewer its functions are combined with foul sewer.
Foul sewer	Pipes network that conveys black and/or grey water from households and industries; in combined sewer its functions are combined with storm sewer.
WWTP	Any type of wastewater treatment plant.
SWTP	Any type of storm water treatment plant.
Receiving water	In this study it is mostly a river stretch, but it can be a lake or the sea.

*Table 8: Compartments outside the system – boundary conditions.*

Compartment	Description
Atmosphere	It provides rain to the system and receives gases and energy (heat losses).
Households	They introduce water, nutrients and pollutants.
Industry	It introduces water, nutrients and pollutants.
Agriculture	It is a source of nutrients and pollutants (e.g. pesticides).
Groundwater	It exchanges water and other substances with several system elements.
Surface water	It receives the output of the receiving water; it can be another river stretch, a lake or reservoir, coastal water, transitional water.
System administration	It exchanges energy and money with the requiring processes.
Residuals disposal	Sink for any other outflow from the system, e.g. sludge.

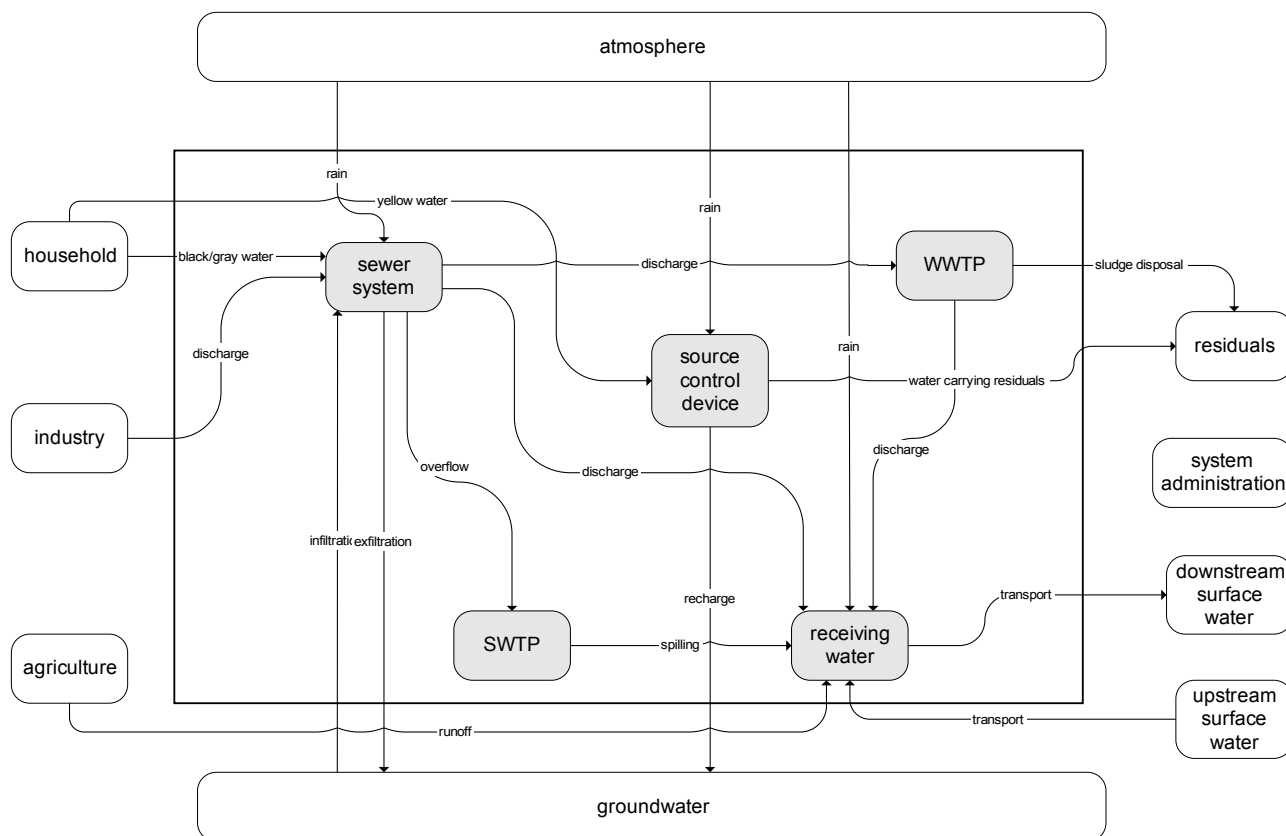

Figure 16: Example of possible flow diagram for water.

The list below contains the description of the major indicators and the evaluation instruments adopted in this study. Relatively to the DIPSIR framework, they are mostly pressure indicators.

- Pollutants: BOD, COD, TN, TP, Zn. They are considered as the most important pollutants for which data are commonly available, indicative of organic pollution (BOD and COD), of eutrophication (TN and TP) and of toxic contamination (Zn). Zinc was selected among other heavy metals since its loads in the case study basin are much higher than for the others and it is the only one which has a concentration almost always above the detection limit, also in the effluent of WWTPs. Other substances like xenobiotics, endocrine disruptors, etc. are also relevant to assess the state of an urban river catchment and they could be analysed applying the tools presented in this work.
- Sewer mass balances for water, BOD, COD, TN, TP, Zn. They are calculated as the substance flow coming out of the sewer minus the flow entering the sewer, all divided by the inflow. Such mass balances are not likely to be closed due to the data-poor conditions, but they give indications on the quality of measurements and estimations and can suggest the presence of unconsidered substance flows.
- Discharges in receiving water by industries, households, sewers, WWTPs and agriculture. It highlights which are the main stressors on receiving water bodies and their relative pressure on them. A ranking of intervention priorities can be made at basin scale to tackle problems more efficiently.
- Parasite water entering the sewer. Mainly function of the sewer network age and materials, parasite water negatively affects treatment performance by dilution and hydraulic

overloading. It can also reveal the presence of possible exfiltration, cause of sanitary risk of groundwater contamination.

- Stormwater discharged in the receiving water. It is a direct pollutants discharge in the receiving water body from combined sewage and surface wash-off, entailing hydraulic stress as well.

## 5.3 Substance flows

Fluxes of substances are calculated from available data and in order to allow the comparison of catchments with different sizes, values are normalized by inhabitants connected to the sewer network. The derived fluxes are represented in a diagram by means of arrows with thickness proportional to the flux value (Sankey diagram). The specific tasks necessary to perform the calculations are illustrated with the case study.

### 5.3.1 CALCULATIONS

**Water** – The measured water flows in the system are from sewer to WWTP (from WWTP to receiving water it is assumed to be the same), at the closing section of the river basin and the effluents of monitored industries.

Water from households is estimated knowing the number of inhabitants (connected and not connected) and assigning a *pro capita* water use.

A fraction of the rainfall – the yearly rainfall in the basin was 1005.6mm, average of 11 measurement stations – function of the impervious area in the basin, was routed through the sewer system (stormwater) and the remaining rainfall was considered to end up directly in the receiving water body or to drain into the water table or to evaporate. The impervious area connected to the sewer system was estimated to be 26.26 km<sup>2</sup>, resulting from analysis of available maps of the municipalities; this corresponds to 24% of the connected urban areas.

Infiltration was calculated by subtracting water flows from households and industries from the dry weather flow (DWF) entering the WWTP. The dry weather flow for each day of the year was calculated as the minimum of the daily inflows within a range of 10 days before and 10 days after that day (in total 21 days) and it expresses the flow without rainwater, with the assumption that at least one day of twenty-one is a dry day (Jardin, 2003).

The water flow discharged directly into the receiving water body (CSO) was calculated as the total stormwater entering the sewer network minus the amount of stormwater treated in WWTPs. The flow of treated stormwater is the total water flow entering WWTPs minus the dry weather flow (Jardin, 2003).

**Pollutants** – No pollutant loads have been estimated for stormwater since no data are available on this regard for the Nete basin and any estimation would have entailed unacceptably large uncertainties. Only the zinc content of stormwater coming from roofs and gutters washing has been calculated according to Sörme and Langerkvist (2002).

Pollutant loads from households (Table 4) were estimated from the number of inhabitants and from the assigned daily substance release, which includes grey water as well (VMM, 2001).

The TN and TP loads from agriculture were obtained from data concerning manure application

and the modelling of nutrients release (VMM, 2001). No data exist on agricultural release of BOD and COD.

Pollutant loads from WWTPs and industries were calculated from water flow and pollutant concentration measurements available approximately every 10 days.

### 5.3.2 RESULTS

Mass balances and flows of substances were calculated for each sewer catchment. The analysis at basin level is based on the figures obtained for the individual sewer catchments, except for the data of TN and TP release from agriculture, that were available at basin level only. Referring to the evaluation instruments mentioned in the methodology section, the following results have been obtained.

Water and pollutants (BOD, COD, TN, TP, Zn). Sankey diagrams and associated uncertainties in flows (from Figure 17 to Figure 28) show the substance flows entering, leaving and circulating in the system, by means of arrows whose thickness are proportional to the flows; the bar charts with error bars allow to better visualise the flow estimation uncertainties calculated with the method of Danius and Burström (2001). The substance flowing downstream was calculated for water only (see Figure 17 and Figure 18), due to the absence of water quality measurements in the closing section of the river.

From these figures, it can be seen that some BOD is removed in the sewer and that in the WWTP almost all the entering BOD is treated, while for COD the removal reaches a lesser extent given its non-biodegradable fraction. Concerning nutrients, most TN entering the system ends in the receiving water (~78%), while more than half of the TP entering the system is eliminated by the WWTP (~60%). The nutrient removal performance of the WWTPs is high because all of the plants >10,000PE are equipped with N and P removal and most of the plants with <10,000PE also have P removal.

Sewer mass balances for water, BOD, COD, TN, TP, Zn. Gaps in mass balances ((out-in)/in) were only calculated for the sewer network, with households and industry as inputs (rainfall and parasite water were also considered for the water balance) and WWTP and receiving water as outputs. Figure 29 shows the gaps in the sewer mass balance for the whole Nete basin for the substances taken into account. The chart shows that, for instance for water, the flow measured at the outflow of the sewer system is 6% larger than the water flow estimated to enter the sewer system.

Discharges in receiving water by industries, households, sewers, WWTPs and agriculture. Concerning pressures directly impacting on the receiving water, Figure 30 to Figure 35 show the relative contributions of the different substance loads discharged in the Nete. In those Figures, “sewer ind” and “sewer hh” indicate the loads discharged in the receiving water via the sewer network by industry and household respectively; the other loads are directly discharged in the receiving water.

Parasite water entering the sewer. Infiltration (see Figure 36) is calculated as previously explained. The average is weighed by the volume of wastewater treated by the plant. Except for a few cases, most sewer catchments show values relatively close to the average (~44%), which is in the expected range of values for the sewer network conditions and topography and from the estimations of operators. Negative and very high values can be explained by the poor reliability of imperviousness data for some catchments; also, the small scale of some sewer catchments influences the calculations, since inaccurate data have a larger impact on the consequent

calculations.

Stormwater discharged in the receiving water. The calculated water flows directly discharged into the receiving water body via CSOs (in Figure 37 as percentage of total flow and in Figure 38 compared to the flow treated in the WWTP) show a large variance.

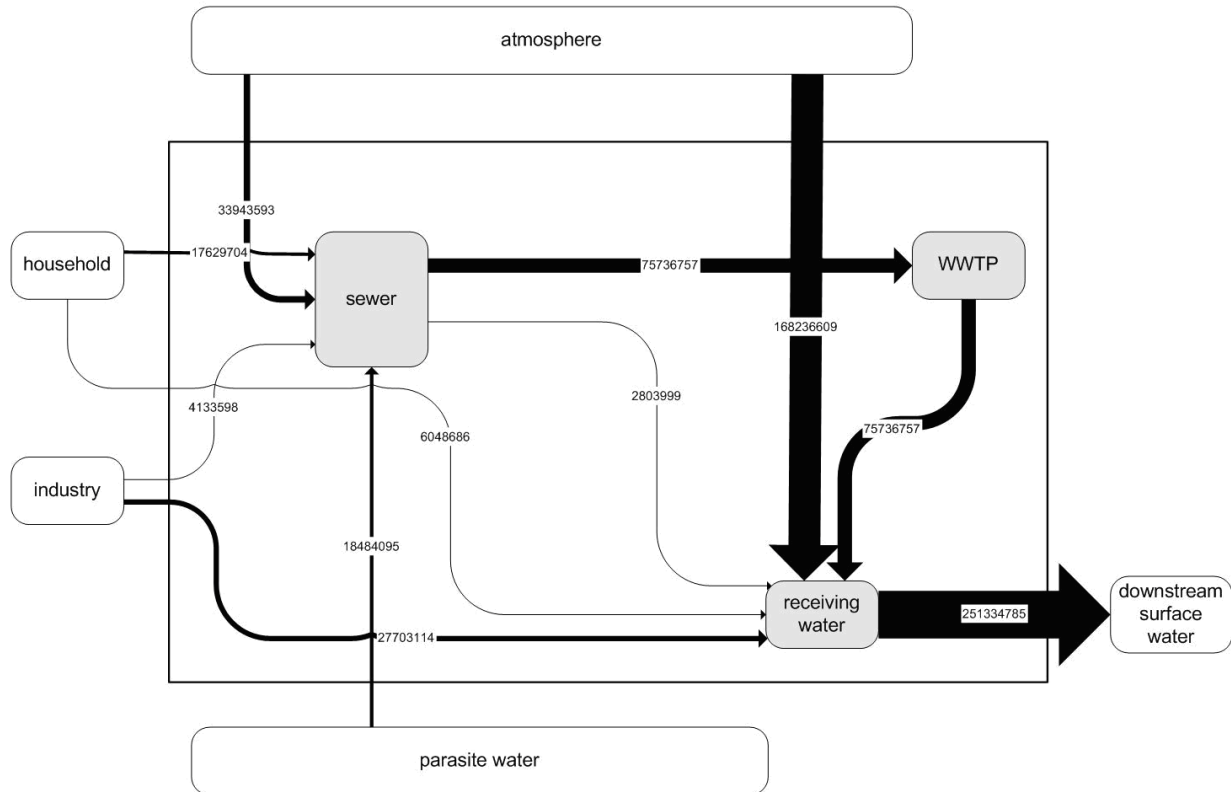

Figure 17: Sankey diagram – Nete basin – water [m³/y].

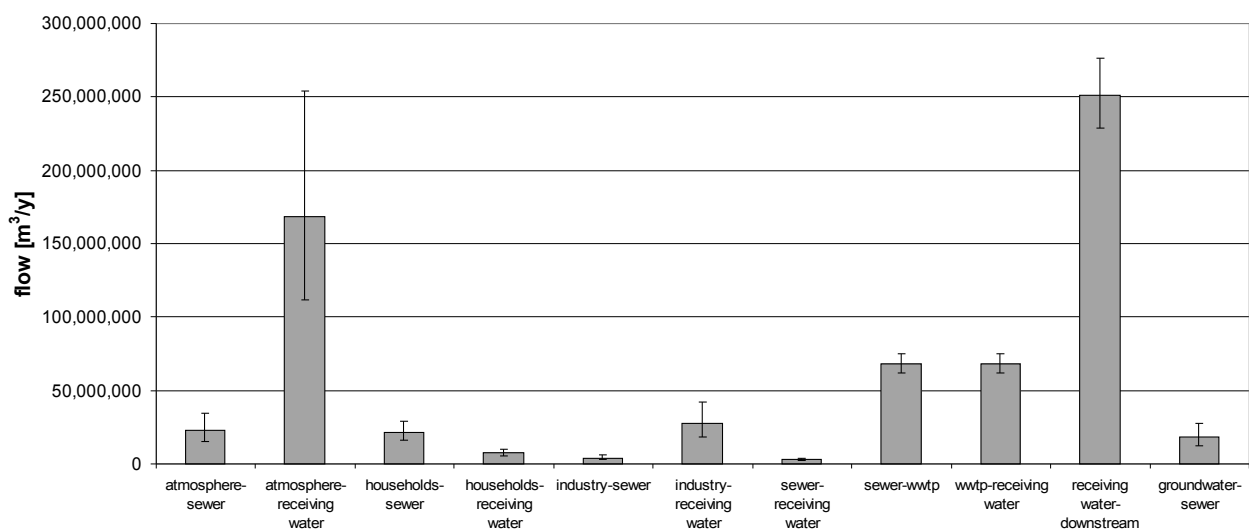

Figure 18: Uncertainty in flow estimation – Nete basin – water [m³/y].

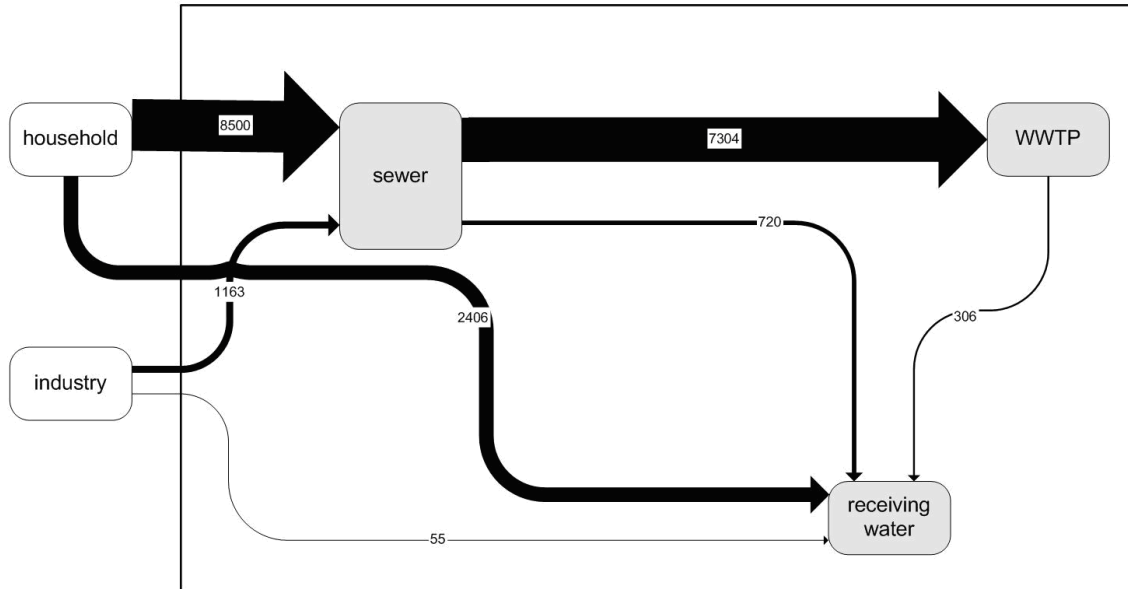

Figure 19: Sankey diagram – Nete basin – BOD [ton/y].

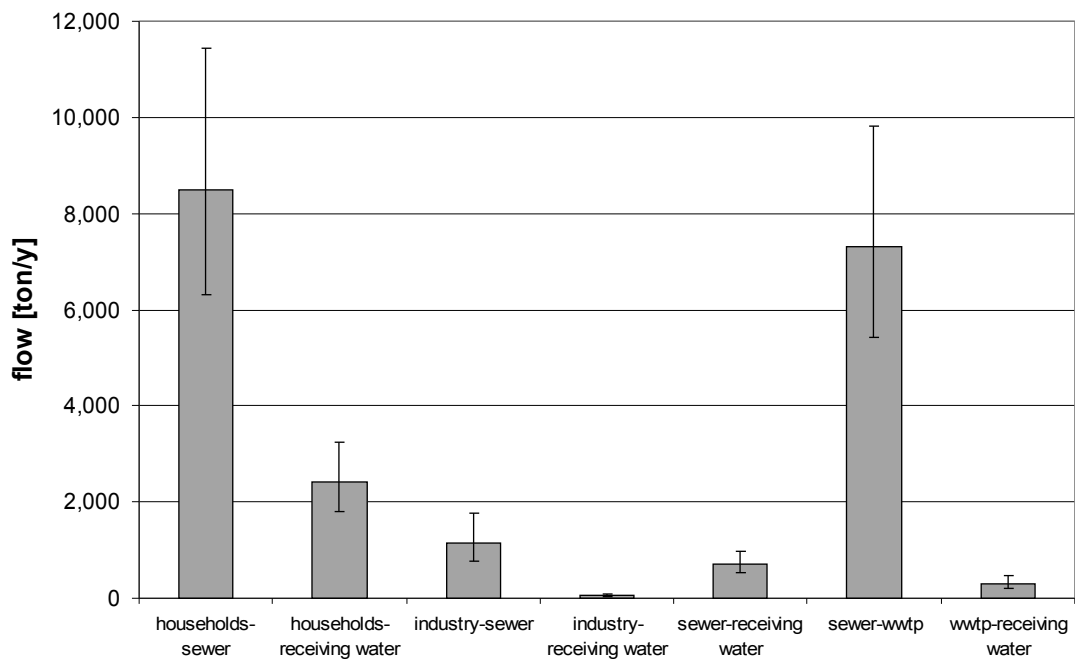

Figure 20: Uncertainty in flow estimation – Nete basin – BOD [ton/y].



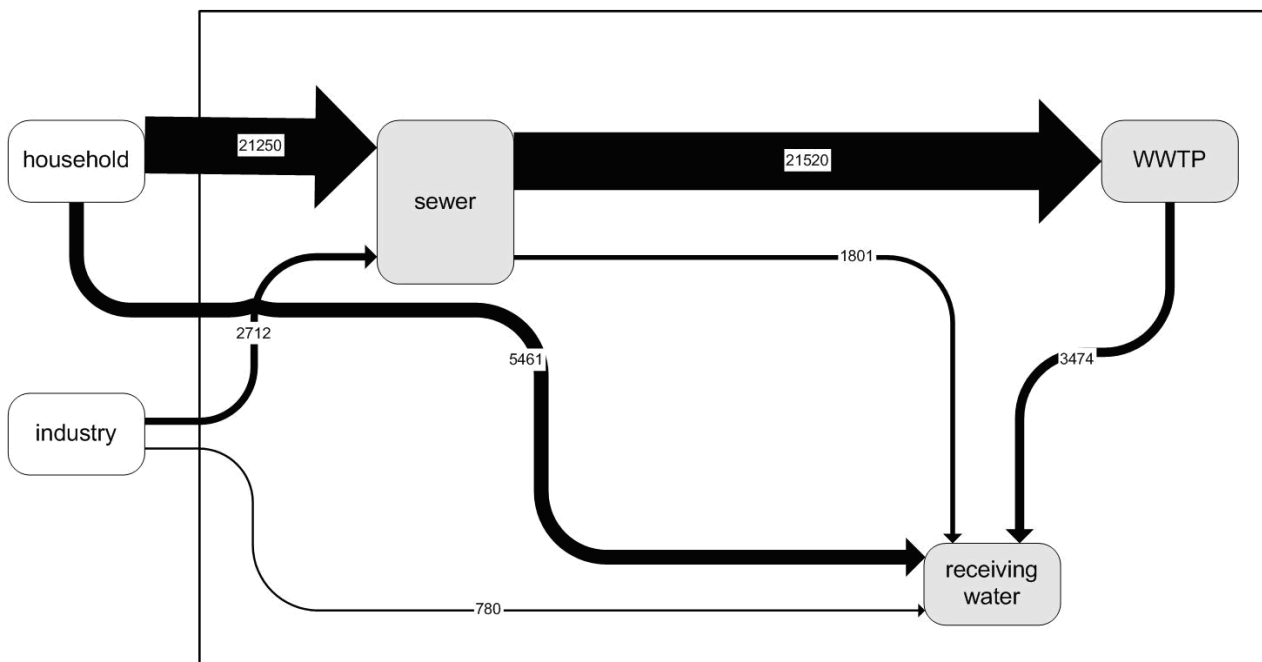

Figure 21: Sankey diagram – Nete basin – COD [ton/y].

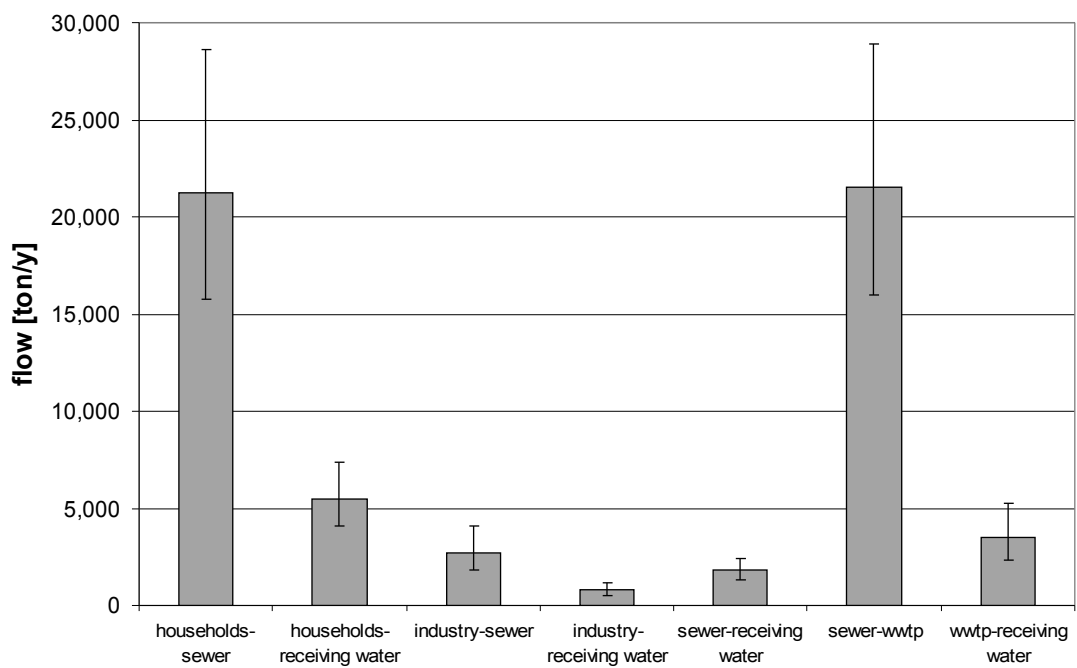

Figure 22: Uncertainty in flow estimation – Nete basin – COD [ton/y].

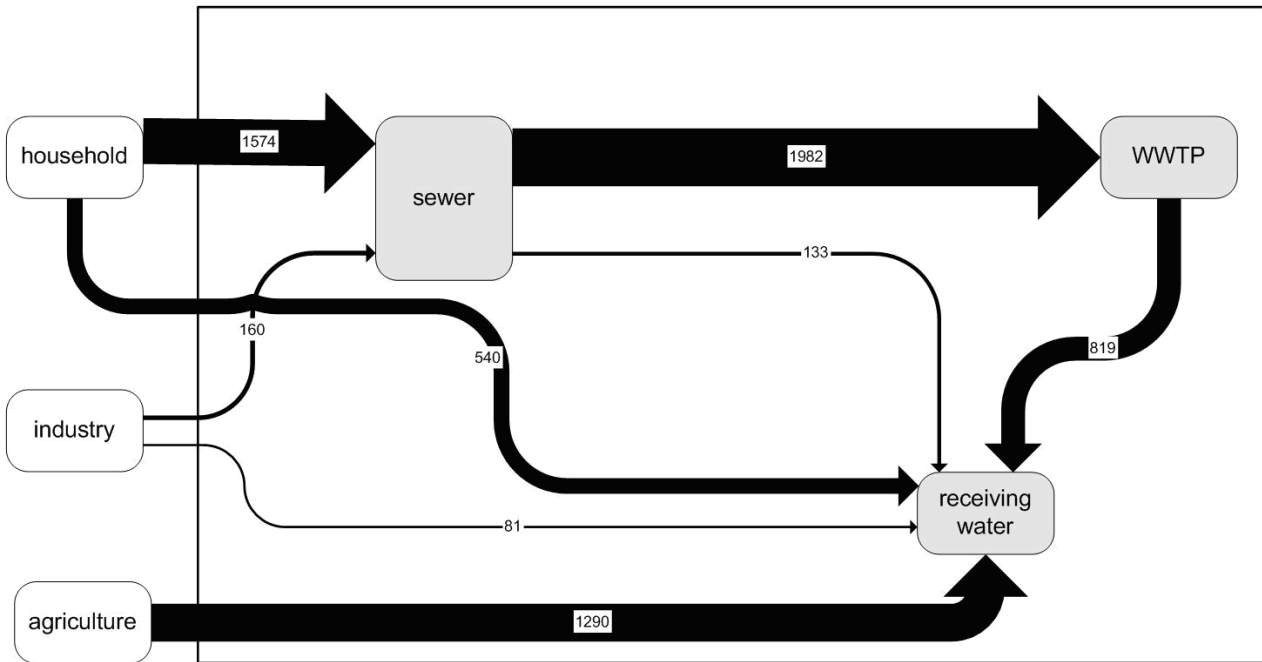

Figure 23: Sankey diagram – Nete basin – TN [ton/y].

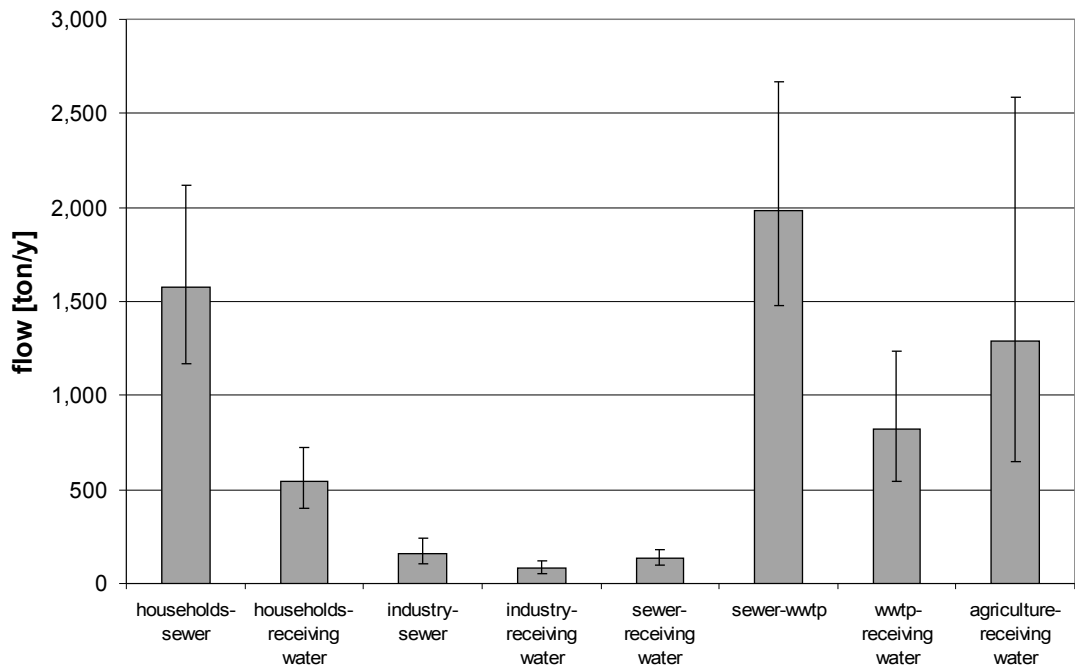

Figure 24: Uncertainty in flow estimation – Nete basin – TN [ton/y].

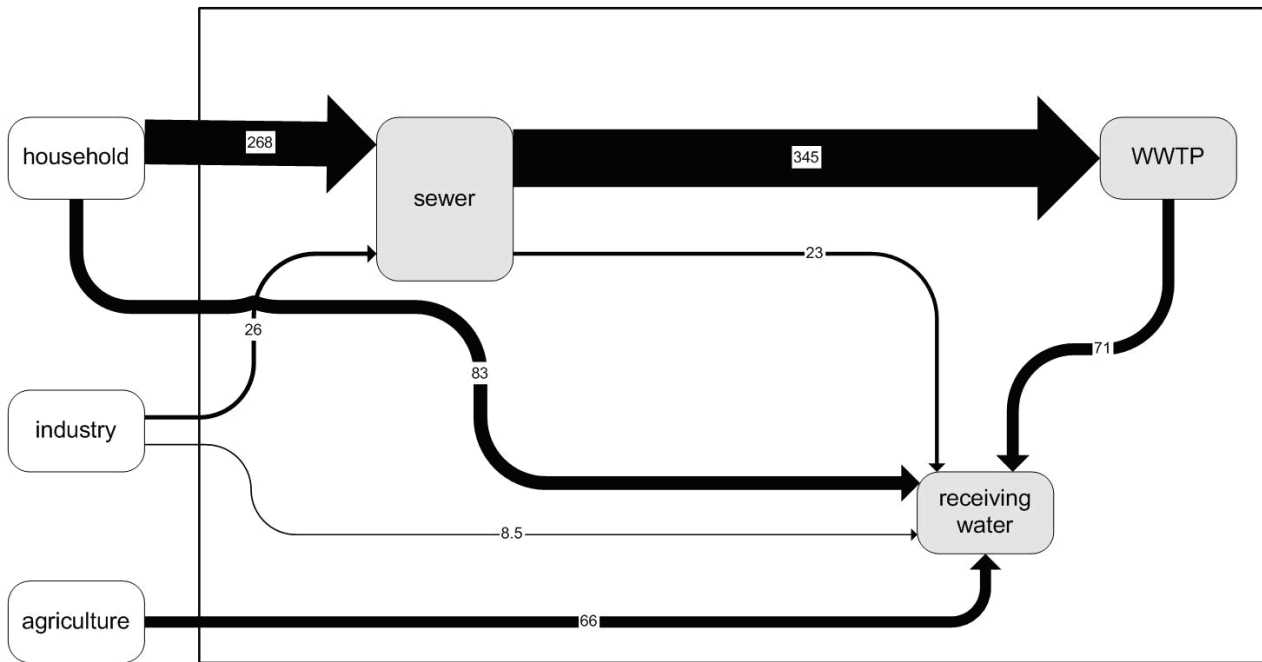

Figure 25: Sankey diagram – Nete basin – TP [ton/y].

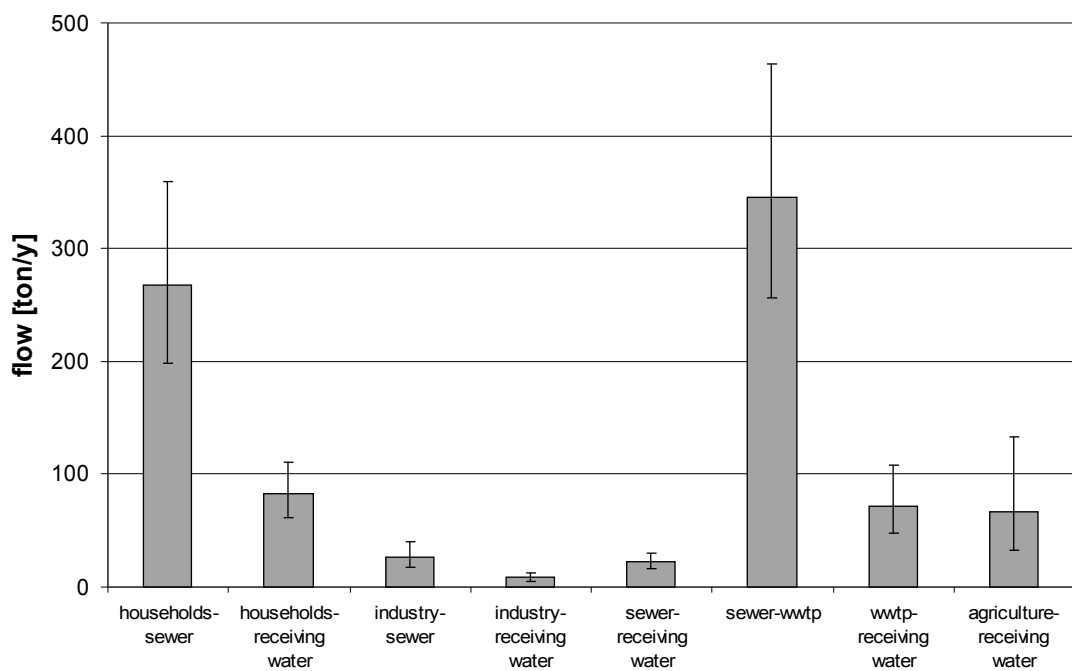

Figure 26: Uncertainty in flow estimation – Nete basin – TP [ton/y].

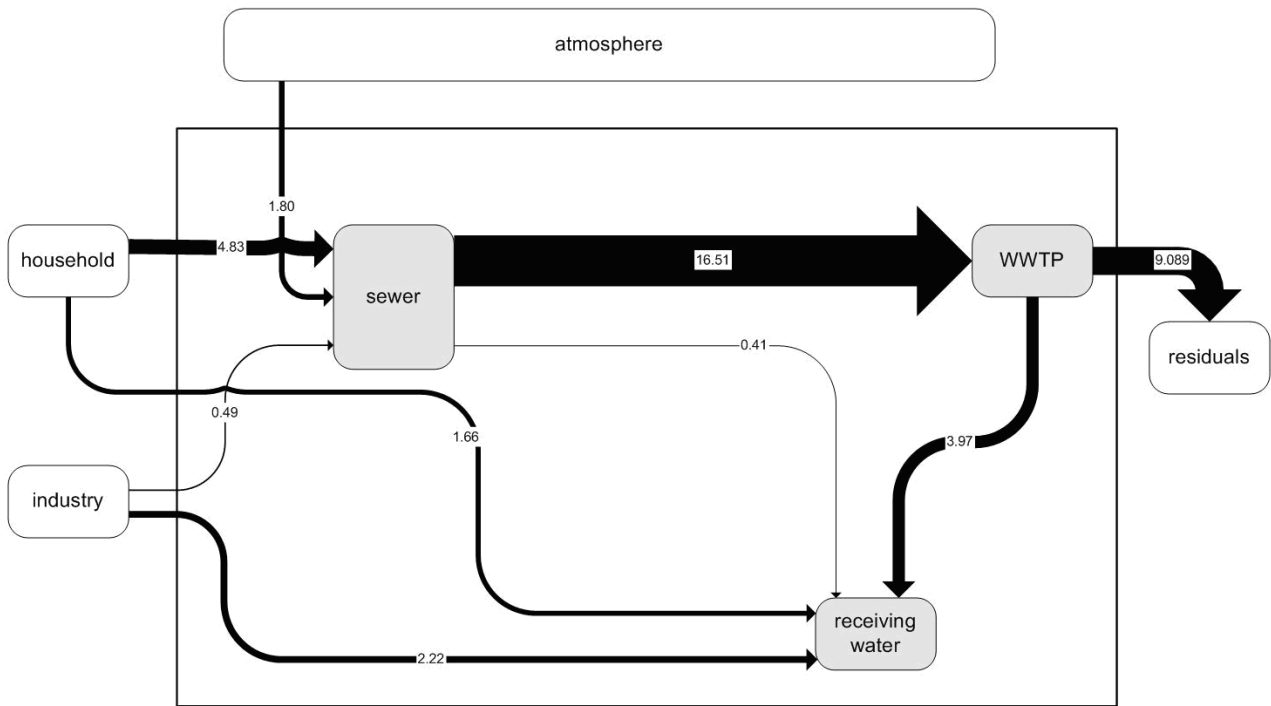

Figure 27: Sankey diagram – Nete basin – Zn [ton/y].

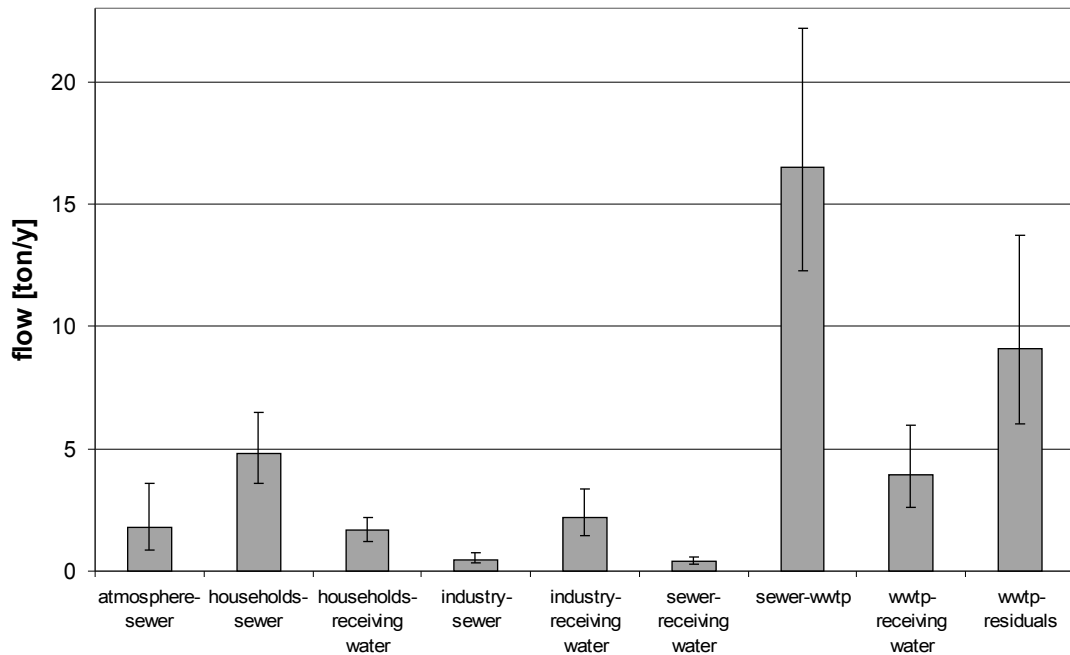

Figure 28: Uncertainty in flow estimation – Nete basin – Zn [ton/y].

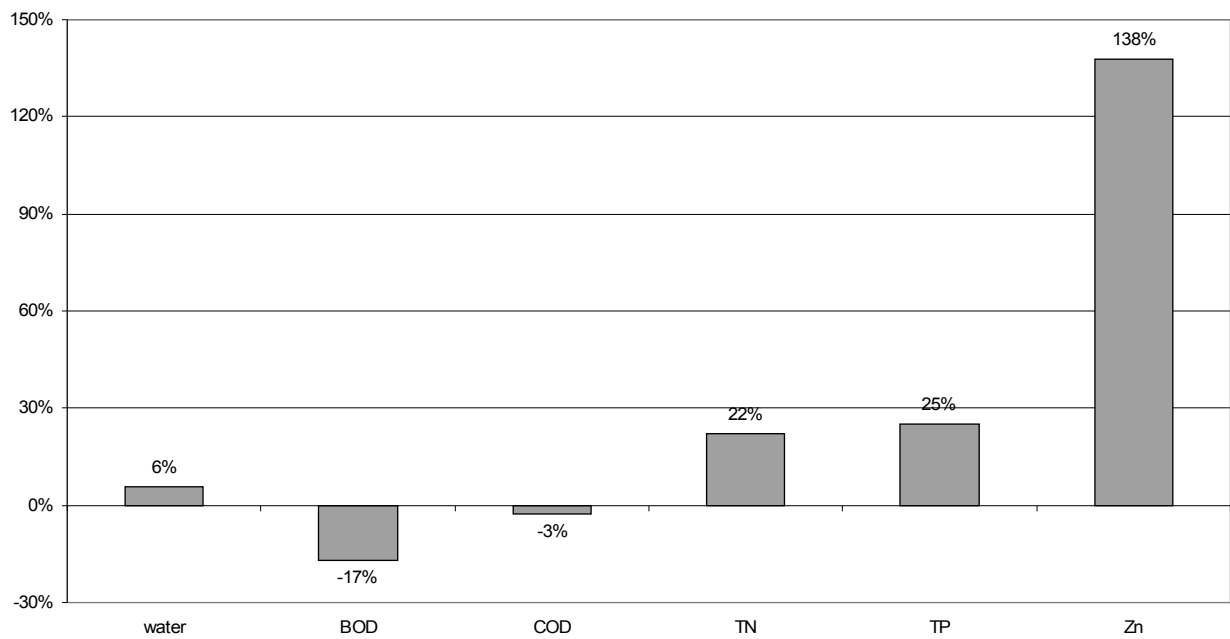

Figure 29: Gaps in the sewer mass balances – Nete basin.

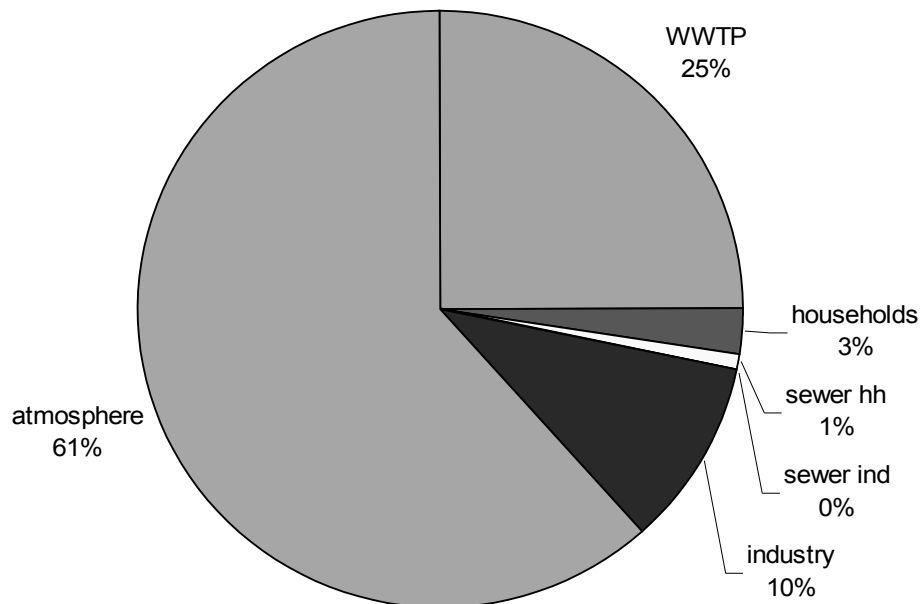

Figure 30: Relative loads into the Nete river – water.

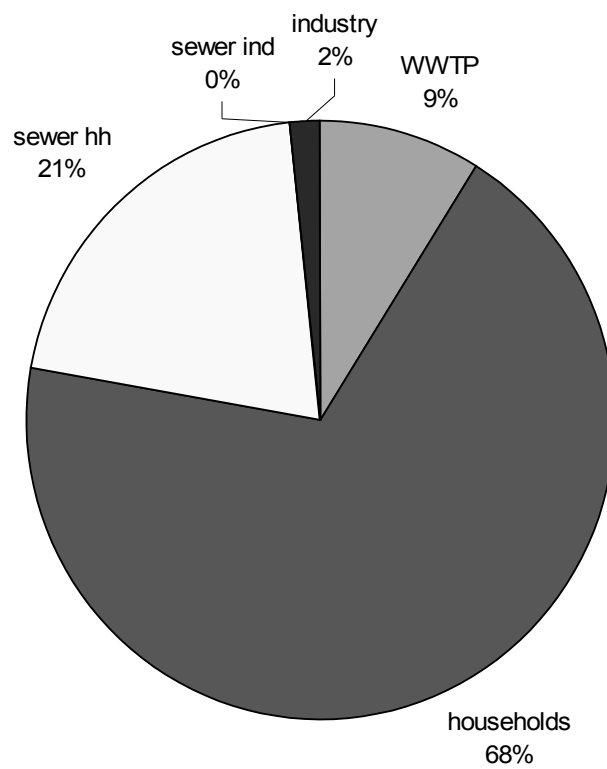

Figure 31: Relative loads into the Nete river – BOD.

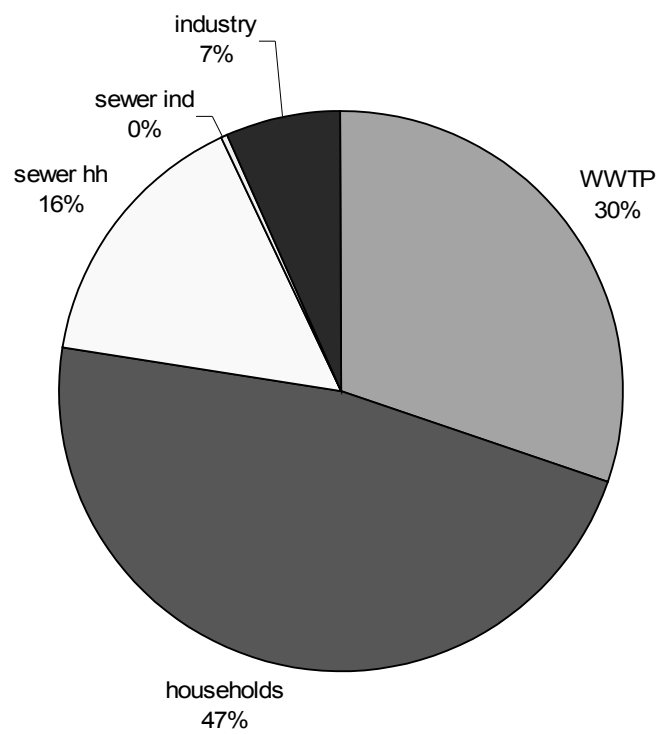

Figure 32: Relative loads into the Nete river – COD.

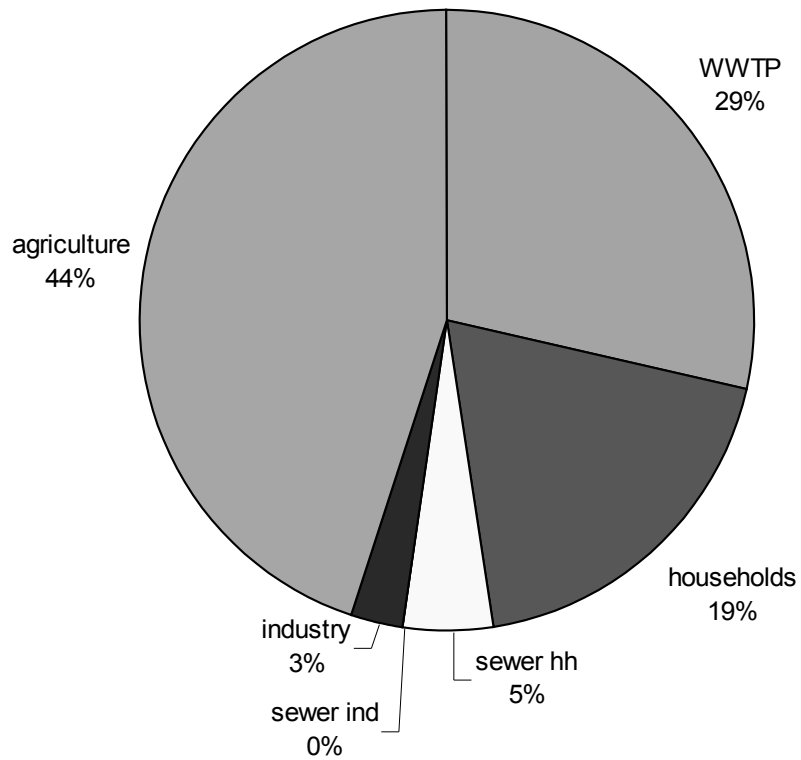

Figure 33: Relative loads into the Nete river – TN.

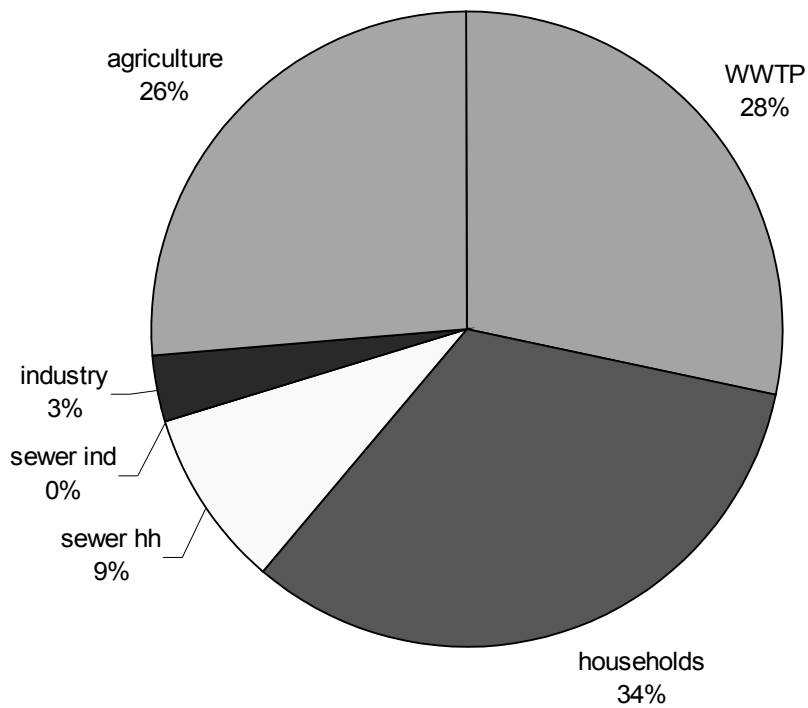

Figure 34: Relative loads into the Nete river – TP.

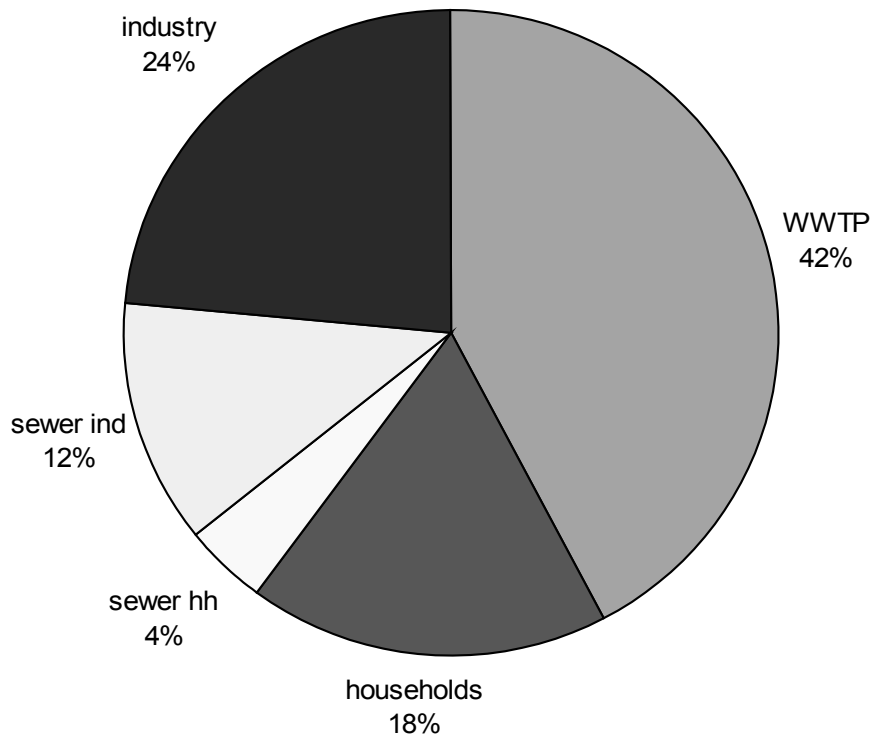

Figure 35: Relative loads into the Nete river – Zn.

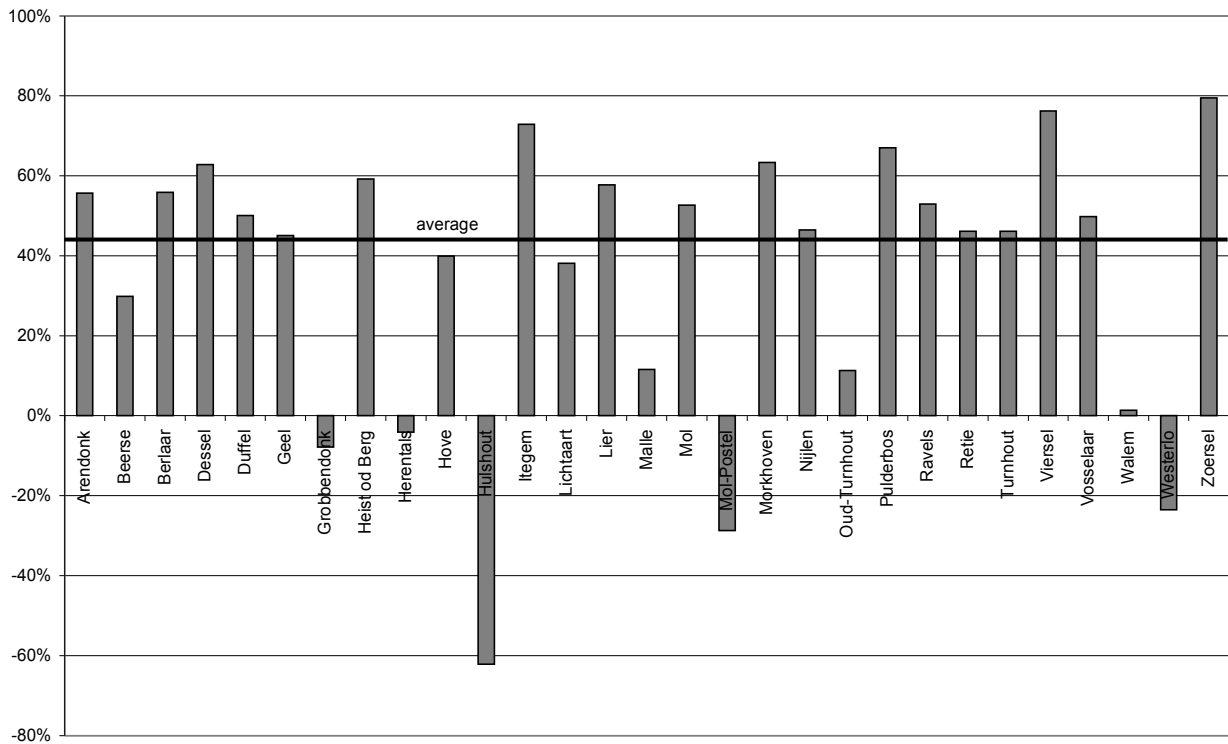

Figure 36: Infiltration water as percentage of DWF.



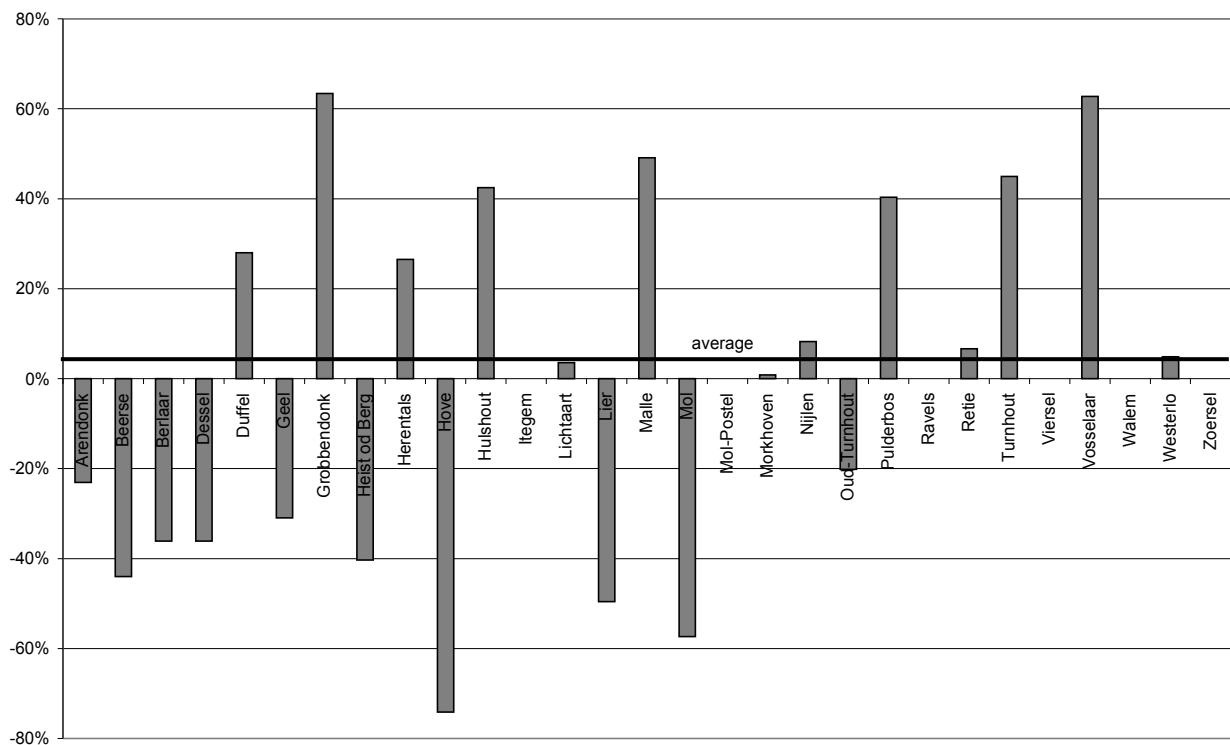

Figure 37: Percentages of estimated CSOs relative to the total flow entering the sewer.

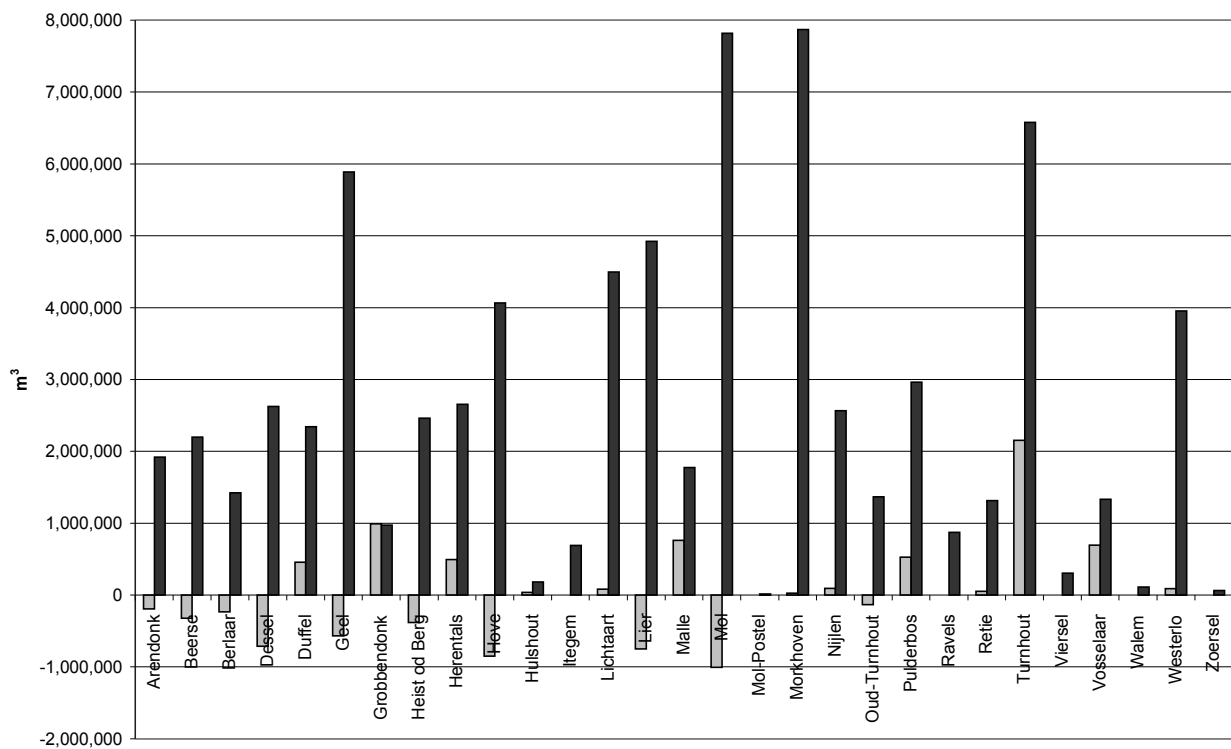

Figure 38: Estimated CSOs (light grey) compared to WWTP inflows (dark grey).

### 5.3.3 DISCUSSION

Combining the information obtained from substance flow calculations and from mass balances with information provided by Aquafin, the following conclusions can be drawn:

*Water* (Figure 17 and Figure 30) – In the Nete basin the groundwater table is rather high (causing infiltration) and several ditches are connected to the sewer system, contributing to loads of parasite water (Figure 36) and of pollutants, especially in rural areas. Furthermore, some CSO outlets are sometimes letting river water in the sewer system, for lack of flap valves and high water levels in river and ditches.

*Pollutants* – The mass balances of TN (+22%) and TP (+25%), as shown in Figure 23, Figure 25 and Figure 29, suggest that the unaccounted ditches connected to the sewer network introduce significant loads from agriculture, to which BOD and COD loads should also be associated. This, together with the mass balances for BOD (-17%) and COD (-3%) shown in Figure 19, Figure 23 and Figure 29, leads to the conclusion that organic pollution is degraded in the sewer. As expected, BOD is removed to a larger extent than COD. Concerning zinc (see Figure 27 and Figure 29) the main zinc sewer inflow that are not taken into account are probably the zinc content of stormwater (only the contribution coming from roof wash-off was considered in the balance) and of tap water; this leads to a 138% gap in the zinc mass balance.

Another interesting aspect to be noted is that the ratio between the flux from the sewer to the WWTP and the flux from the sewer to the receiving water is much higher for water than for pollutants. This can be due to the fact that the pollution from sewer to receiving water comes from collected but untreated wastewater, which is much less diluted than the wastewater going to the WWTP. Indeed, in these calculations no rainwater goes to the untreated discharge (as there was no information on the draining catchment) while for the input to the WWTP rainwater and infiltration are included since the data are measured at the WWTP influent.

From Figure 30 to Figure 35 it appears that untreated wastewater from households is the main stressor for acute oxygen depletion (BOD, 89% of load) for delayed oxygen demand (COD, 63%) and for eutrophication (TP, 43% and TN, 24%). Agriculture also has a relevant impact on eutrophication (TN, 44% and TP, 26%); note that no data were available on BOD and COD loads from agriculture. WWTPs contribute substantially to all loads but are in no case the main stressor; they are for zinc, but only apparently because zinc contained in stormwater is significantly underestimated and other sources are not considered in this study.

Concerning the calculated water flows directly discharged into the receiving water body via CSOs (Figure 37), negative figures possibly indicate stormwater entering the sewer system via CSO due to a combination of a high water level in the river (higher than the sewer water level) and a lack of flap valve. However, the average value of 4% (relative to the total water entering the sewer) for the whole Nete basin is not far from percentages found in literature (e.g. Schlütter and Mark, 2003). The same behaviour – i.e. large variance for individual basins, but average in agreement with literature – was found for sewer mass balances.

This underlines an important aspect in this type of studies: the spatial scale chosen. For large areas like a river basin, results are likely to fall in the narrow range of results found in similar studies, since several different contributions compensate each other, producing an average typical for a certain kind of large area. However, for small catchment areas with sewer catchments of small WWTPs, local boundary conditions and uncertainties play a major role and results vary to a large extent in seemingly similar areas.

It is expected that also the temporal scale of such studies has a similar influence on the results,

with assessments over short periods showing high variability and long periods producing results closer to typical values.

However, the large uncertainty associated to the water flows (see Figure 18) does not allow to draw definitive conclusions on such delicate issues as CSOs, where small changes in flow calculations have large consequences on CSO volume estimations.

## 5.4 Conclusions

SFA allowed to identify the pollution paths and the pressures on the receiving water. The most significant stressors in the Nete basin appear to be the discharge of unconnected households, followed by agriculture (limited to nutrient emissions) and WWTPs. Limited data availability and low detection limits make the evaluation of other pollutants (e.g. heavy metals) very difficult.

A hypothetical list of actions to reduce the pressure on the Nete river would be:

1. treat the wastewater collected by the sewer systems but still discharged untreated in the receiving water;
2. introduce best management practices in the agricultural sector; it is to be noted that, on the other hand, reducing emissions from agriculture appears to be a much more complex (socio-economic) issue than from the UWWS;
3. improve the performance of the UWWS by upgrading the WWTPs and by reducing infiltration; the high percentages of infiltration water entering the sewer systems may be seen as one of the most important problems to be solved in the Nete basin, leading to hydraulic overloading of WWTPs, excessive pumping costs and potential health risk. However, it is a problem with both well established and innovative solutions available.

Concerning the quality of the results, the choice of the spatial scale of the study is crucial. Data availability and local factors should be carefully accounted for in that regard. Uncertainty analysis reveals difficulties in properly assessing quantities like CSOs, which are relatively small numbers derived from several larger, uncertain quantities.



## INDICATORS

*Parts of this chapter have been published as:*

**Benedetti, L., Dirckx, G., Bixio, D., Thoeye, C. and Vanrolleghem, P.A. (2006).** *Environmental and economic performance assessment of the integrated urban wastewater system. Journal of Environmental Management (resubmitted).*

Once the critical sub-systems exerting the stronger pressure on the receiving water are identified by using substance flow analysis, further investigation has to be carried out to reduce the set of possibilities to implement measures to improve the water quality. In case this analysis has to be performed on the wastewater collection and treatment systems present in a river basin, the evaluation of performance indicators can help in assigning priorities for intervention (Figure 39).

### 6.1 Adopted indicators

The substances analysed in the study were: water, BOD, COD, total nitrogen (TN), total phosphorus (TP) and Zn. Water was selected since the analysis of its flows can reveal problems such as in- and exfiltration, WWTP overload and hydraulic stress to WWTP, sewers and receiving water body; BOD and COD are indicators of organic pollution leading to oxygen depletion and CO<sub>2</sub> emission; TN and TP reveal the eutrophication potential in the receiving water; Zn is the most detectable heavy metal (therefore measurements are fairly reliable) and is representative of toxic contamination.

The following list describes the major indicators adopted in this study. Note that costs and energy consumptions are the lumped values for WWTPs and sewers. The indicators are calculated on a yearly basis.

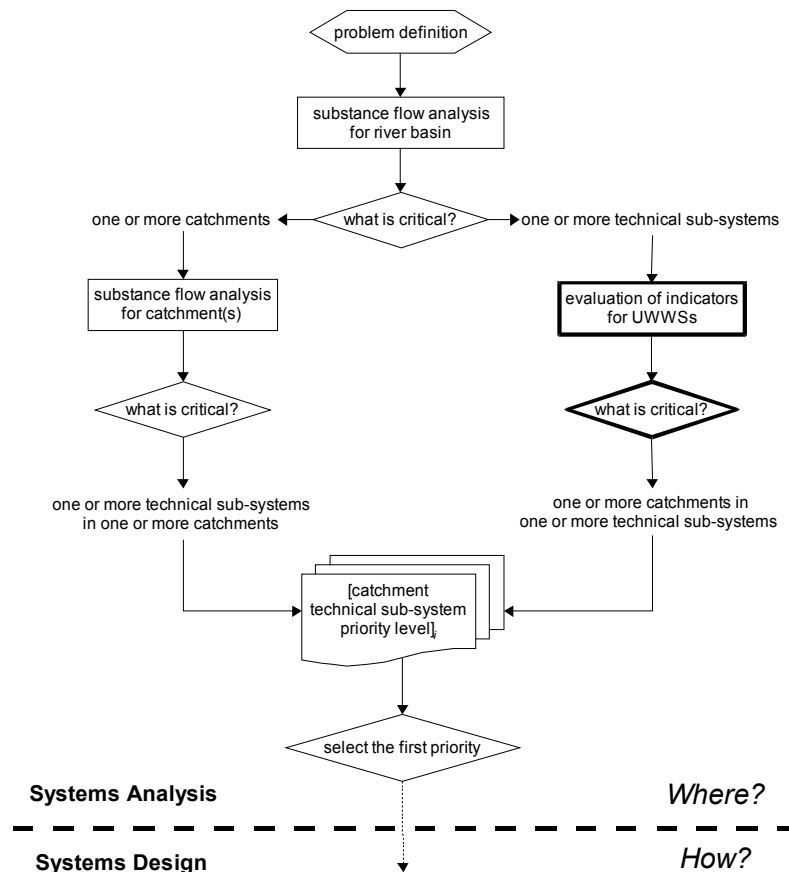

Figure 39: The evaluation of indicators within Systems Analysis.

- Loads of pollutants entering WWTPs per inhabitant connected [ $g \cdot d^{-1} \cdot inh^{-1}$ ] and per drained area [ $g \cdot d^{-1} \cdot m^{-2}$ ]: they provide an indication of the presence of industrial discharges in sewer catchments and on other structural characteristics, like type of urbanisation, presence of local treatment devices (e.g. septic tanks), etc.
- COD and TN based population equivalent (PE) load [ $g \cdot d^{-1} \cdot PE^{-1}$ ]; comparison with inhabitants connected, design PE and percentage of industrial flow: TN should be favoured as a basis to calculate PE load because it is more conservative than COD in the sewer system. Comparing these parameters can reveal cases of plant overload or underload, or excessive industrial connections.
- WWTP removal efficiencies of pollutants [% of incoming load]: they express the capacity of WWTPs to prevent pollutants to enter the water body from the sewer system. Still, pollutants are not actually removed, but their path is altered so that they can be disposed of with less harm to the environment (e.g. nutrients contained in waste sludge can be used as fertilizers).
- Total, operational and variable cost, also expressed per unit of (equivalent) total pollutants mass removed [ $€ \cdot kg^{-1}$ ]: it indicates the economic efficiency of the wastewater treatment. In this study, total costs include all accounted costs, operational costs are total costs without capital costs and variable costs are operational costs without personnel costs. Capital costs are annualised assuming a depreciation period of 30 years for civil works and of 15 years for electro-mechanical equipment and a yearly discount rate of 4%. Costs are

normalised by the equivalent mass removed and are calculated by weighting several pollutants differently. The equivalent mass is obtained by summing the pollutant masses removed, each multiplied by a weight, with two different sets of weights (see Table 9):

1. the first set is derived from the Flemish legislation for industrial discharge pollution fees (hereafter indicated as DPF)
  2. the second is the oxygen consumption potential (OCP) (Balmér, 2000).
- e. *Costs per PE load [ $\text{€}\cdot\text{PE}^{-1}$ ]*: they express the economic efficiency of wastewater systems as a function of population and industry served. It is a typical benchmarking indicator when data are clustered for PE load classes of WWTPs (Bode and Lemmel, 2001).
- f. *Energy consumption per volume of treated wastewater [ $\text{kWh}\cdot\text{m}^{-3}$ ]*: it indicates the energetic efficiency of treatment. The energy consumed (due to aeration, to wastewater pumping and to sludge treatment) is considered to be closely linked to the amount of wastewater treated, given the assumption that pollutant concentrations do not have significant variations between plants with mostly municipal influent.
- g. *WWTP plant footprint compared to wastewater treated [ $\text{m}^2\cdot\text{m}^{-3}$ ]*: it represents the efficiency of surface occupation of WWTPs, specific for the volume of treated wastewater. In densely urbanised areas the plant footprint can be a critical factor for process selection. This can be an issue also in open land, where larger processes use agricultural space and ultimately destroy natural habitat.
- h. *WWTP effluent concentration for pollutants [ $\text{g}\cdot\text{m}^{-3}$ ]*: it is an emission-based indicator; it is compared with legislative limits.
- i. *Infiltration water entering the sewer systems [% of DWF]*: it is mainly a function of the sewer network age and materials. Infiltration negatively affects treatment performance by dilution and overloading. It can also reveal the presence of possible exfiltration and be a cause of sanitary risks (groundwater contamination).
- j. *Stormwater discharged in the receiving water [% of DWF]*: it is a direct pollutants discharge in the receiving water body from combined sewers and surface run-off, entailing hydraulic stress as well. It is commonly addressed as combined sewer overflow (CSO).
- k. *Ratio of pollutants measured per pollutants discharged in the receiving water [-]*: it is a measure of the self-purification capacity of the river. Low values indicate high capacity, high values indicate low capacity. This indicator is calculated as the ratio of measured concentrations on estimated pollutant loads per volume of water flowing in the river. It was calculated only for the whole Neter river basin given the relative data scarcity of water flow and quality in hydrologic sub-basins; furthermore, generally sewer catchments and hydrologic sub-basins do not match geographically.
- l. *Water quality indexes*: Prati Index for Oxygen (PIO) – based on the ratio of the concentration of dissolved oxygen and its saturation concentration (Prati *et al.*, 1971) – and Belgian Biotic Index (BBI) – based on species counting (De Pauw and Vanhooren, 1983). They have up till now been used in Flanders to report on the physico-chemical and biological status of the surface waters, respectively.

Concerning the exploitation of such proposed indicators by a decision maker, from the environmental point of view the water quality indicators, the effluent concentrations and the EQI removed are the most important, and where they do not conform to predefined standards they should be improved. From the economic point of view, the variable cost efficiency and the energy

efficiency should be improved for the plants with the higher values. Information like the over- or under-loading of plants, the presence of infiltration etc. can be used to find how problems might be solved.

Table 9: Cost weights for pollutants; DPF refers to the Discharge Pollution Fee calculation, while OCP refers to the Oxygen Consumption Potential calculation.

	BOD	COD	SS	KjN	NO <sub>3</sub>	TN	TP
Weight (DPF)	2	1	2	0	0	20	100
Weight (OCP)	1	0	0	18	4	0	100

## 6.2 Results and discussion

### 6.2.1 VALUES OF INDICATORS

This section discusses the obtained values for the indicators. The indicators are available for all pollutants studied, but are presented for COD and TN only, considered as representative for organic pollution and eutrophication potential.

- Loads of pollutants entering WWTPs per inhabitant connected and per drained area.* Figure 40 (left) shows COD, BOD, TN, TP and Zn average loads to the plants and their standard deviations, expressed in grams (milligrams for Zn) per inhabitant per day. Averages and standard deviations are weighted on the basis of the inhabitants connected to the plant. From this chart it can be seen that loads have a rather small variance in the basin. Such small variance – also for indicator c) – is due to the very similar conditions and performances of the biggest plants. Low values could be due to biodegradation in the sewer and to pre-treatment devices (such as septic tanks) at household level. High(er) values could be an indicator of a larger industrial wastewater contribution. Note that the average loads are all higher than the values estimated by VMM for households (Table 4); the only exception is BOD, which is lower than the value by VMM.
- COD and TN based PE load; comparison of inhabitants connected, design PE and percentage of industrial flow.* In Figure 41, the design PE of WWTPs (on the basis of the value  $54\text{gBOD}\cdot\text{inh}^{-1}\cdot\text{d}^{-1}$  used by Aquafin for design) is compared to the actual number of inhabitants connected to the WWTPs and to the load actually entering the WWTPs on a TN basis ( $10\text{gTN}\cdot\text{inh}^{-1}\cdot\text{d}^{-1}$ ), which is less subject to conversion processes in the sewer system than COD. From this chart it emerges that the majority of the studied WWTPs are underloaded, so that more households and/or industries can be connected to them.
- WWTP pollutant removal efficiencies.* Figure 40 (right) shows COD, BOD TN, TP and Zn average removals in the plants and their standard deviations, expressed in percentage. Averages and standard deviations are weighted on the inhabitants connected to the plant. COD and BOD removal are larger than the TN removal, indicating that COD removal is present in all systems, while TN removal is not required in WWTPs smaller than 10,000PE; furthermore, the large dilution in the influents implies that effluent concentrations below the regulatory limits do not result in large removal percentages. Also TP removal is rather high, due to very good removal in all of the bigger plants and to the



presence of chemical phosphorous removal in most of the plants smaller than 10,000PE.

- d. *Total, operational and variable costs, also expressed per unit of (equivalent) total pollutant mass removed.* As Figure 42 shows, capital costs are prevailing especially for sewers, since most of the wastewater collection and treatment systems have been realised or upgraded fairly recently, after the creation of Aquafin in 1990 by the Flemish government. Figure 43 puts in evidence that for the studied systems total costs of WWTPs exceed the ones for sewers and this is due to the fact that only the main collectors and pumping stations are considered, while the extensive municipal sewers have not been included. Figure 44 to Figure 46 present comparisons for all catchments (sewer system plus treatment plant) of total, operational and variable costs in Euro per equivalent kilogram removed (the DPF and OCP). Total costs show a larger variance than operational and variable costs since the prevailing capital costs depend on the year of construction and not on the efficiency of the plant. Another element that clearly emerges from the charts is that the two weighting sets of DPF and OCP give quite similar values for most of the plants, with slightly larger values corresponding to the OCP. Large differences appear only for very small plants, e.g. for Mol-Postel (design capacity 270PE) the combination of no TP removal in the plant and high weight attributed to TP removal in the OCP calculation, leads to a very high costs/OCP value for that plant. According to this indicator (in particular for variable costs), room for improvement is available for the plants in Berlaar, Lichtart, Malle, Morkhoven and Westerlo.

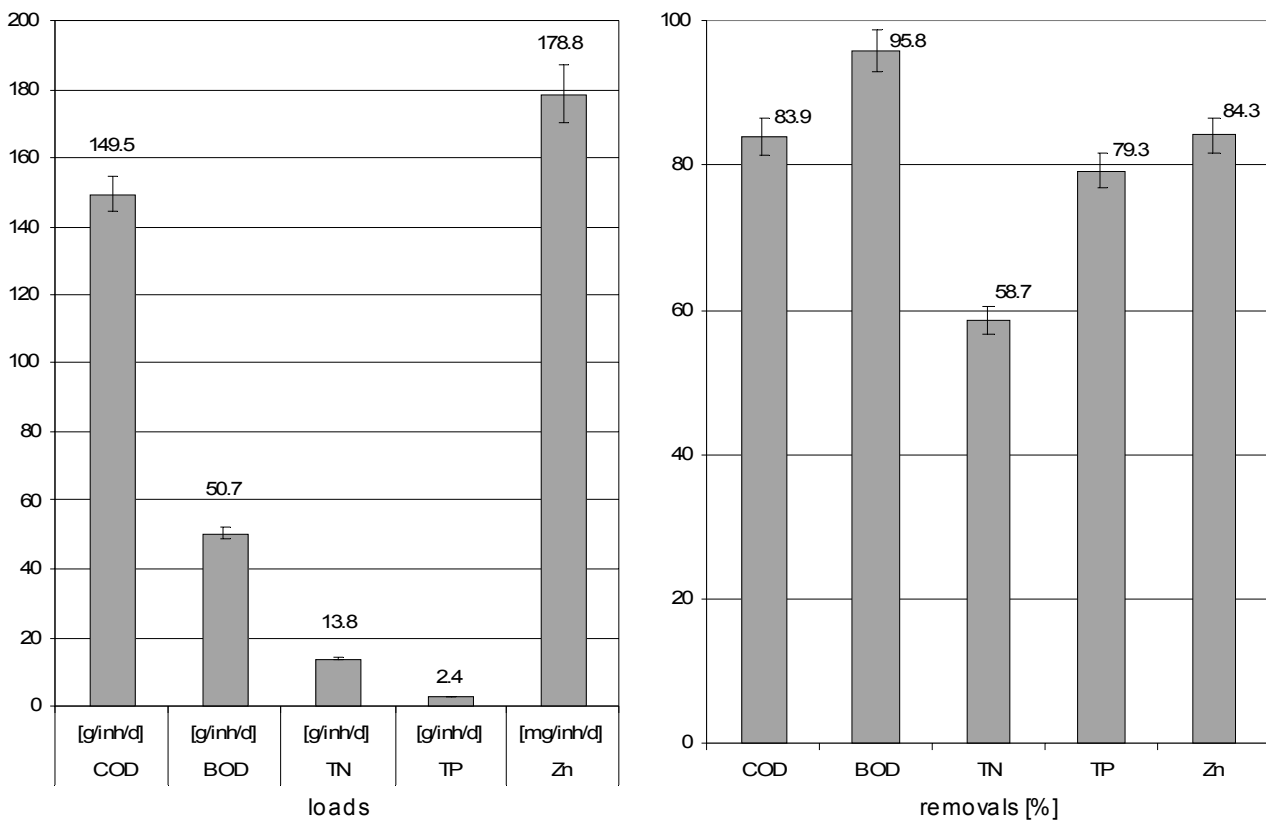

Figure 40: COD, BOD, TN, TP and Zn average loads (left) and removals (right) of WWTPs with standard deviations; averages and standard deviations are weighted on the inhabitants connected to the plant.

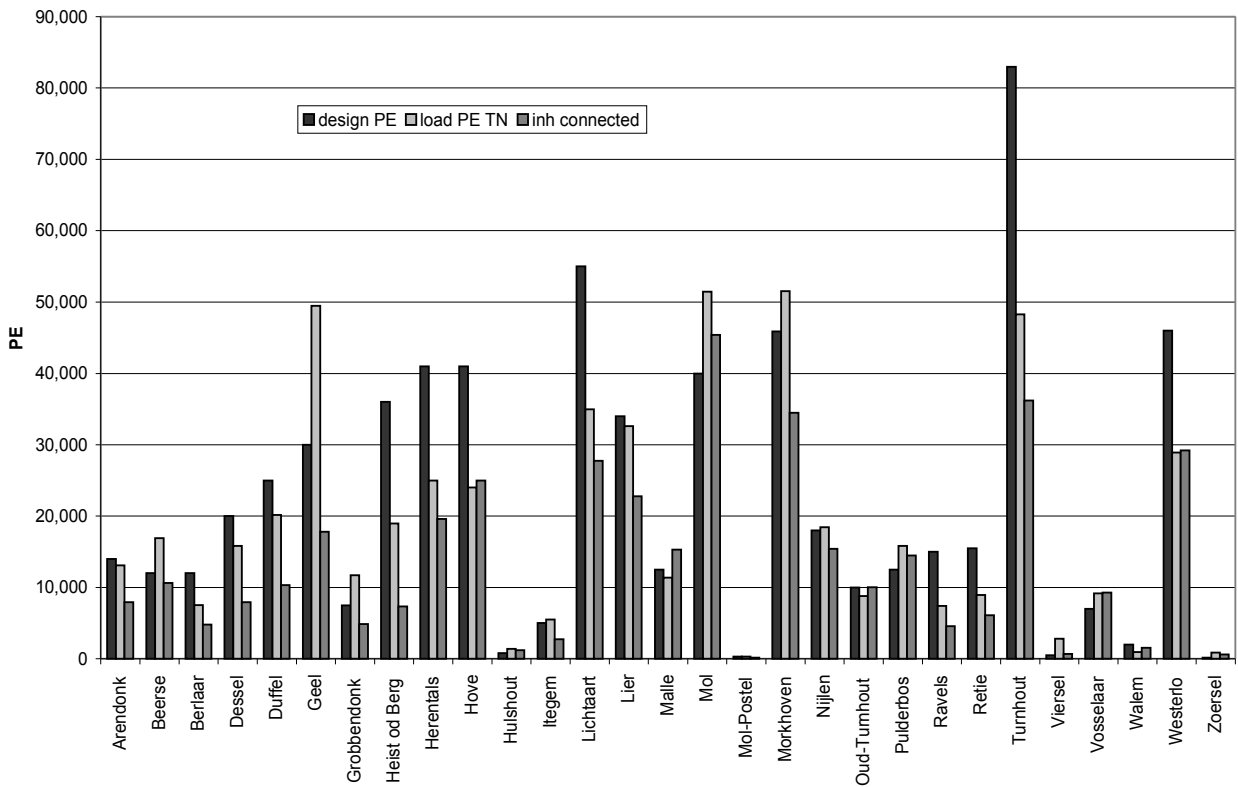

Figure 41: Design PE (on BOD basis), load PE (on TN basis) and actual inhabitants.

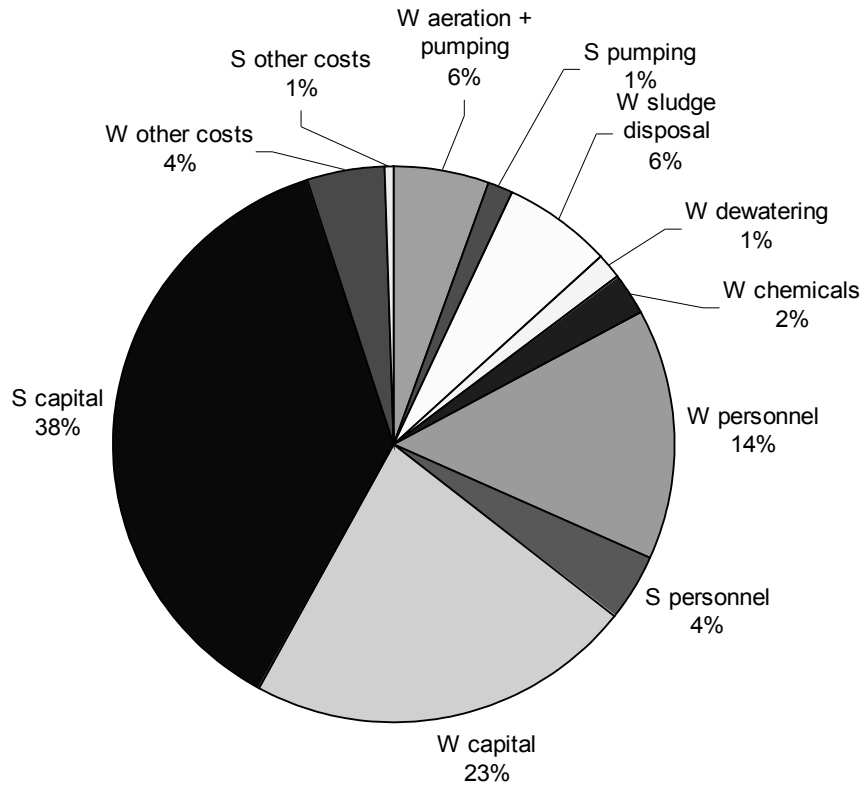

Figure 42: Percentages of total costs for cost categories in sewers (S) and WWTPs (W).

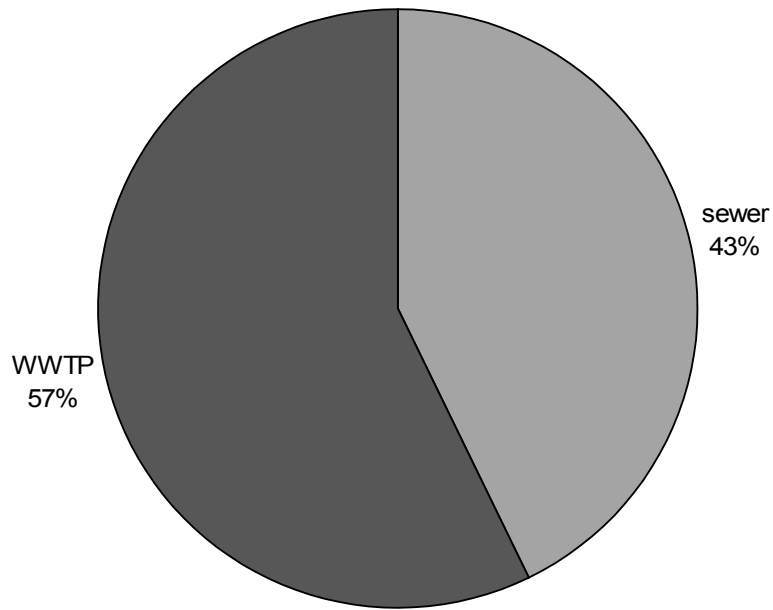

Figure 43: Total costs chart for WWTP and sewers.

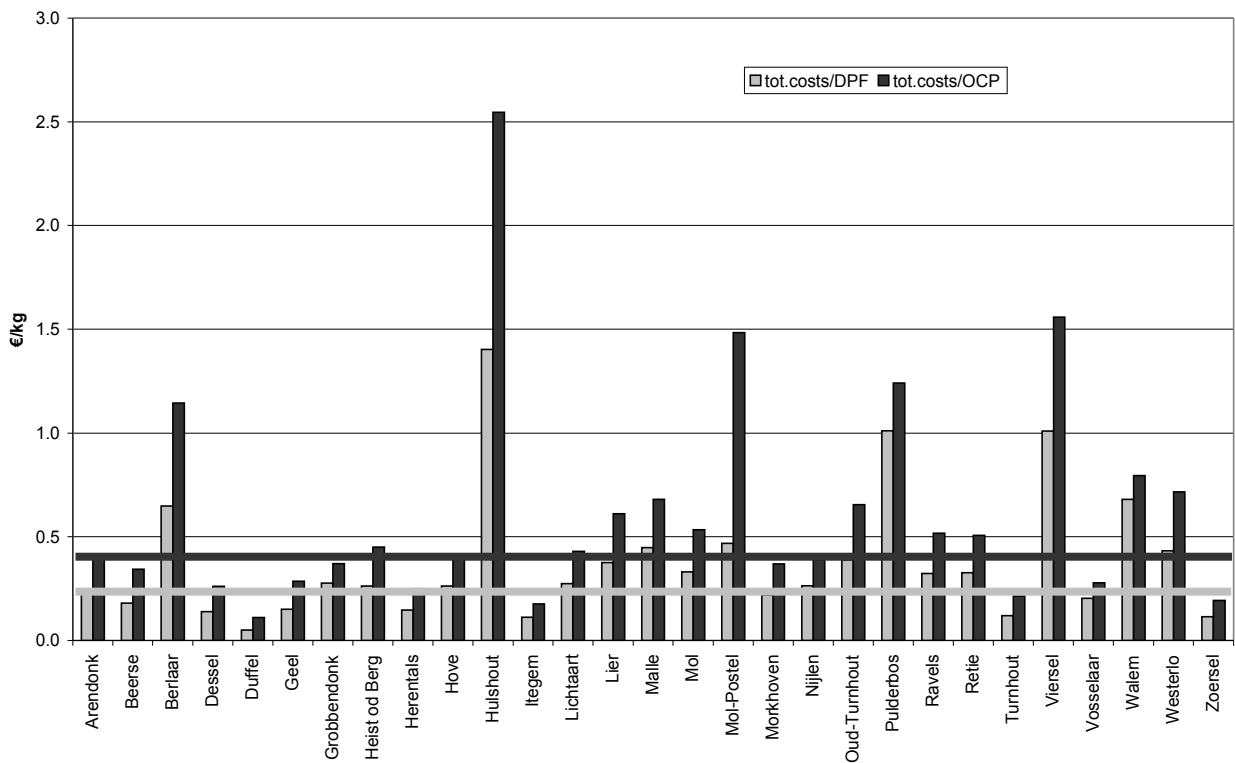

Figure 44: Total costs specific to equivalent pollutant mass removed; horizontal lines show average values.

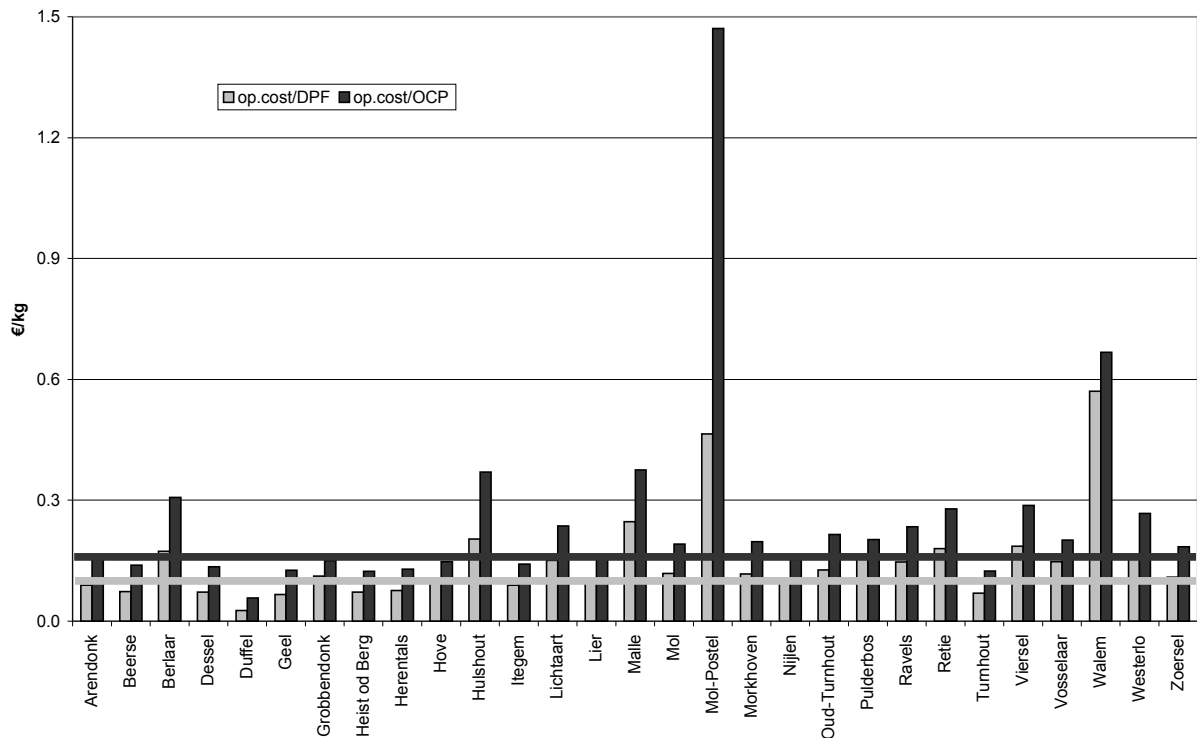

Figure 45: Operational costs specific to equivalent pollutant mass removed; horizontal lines show average values.

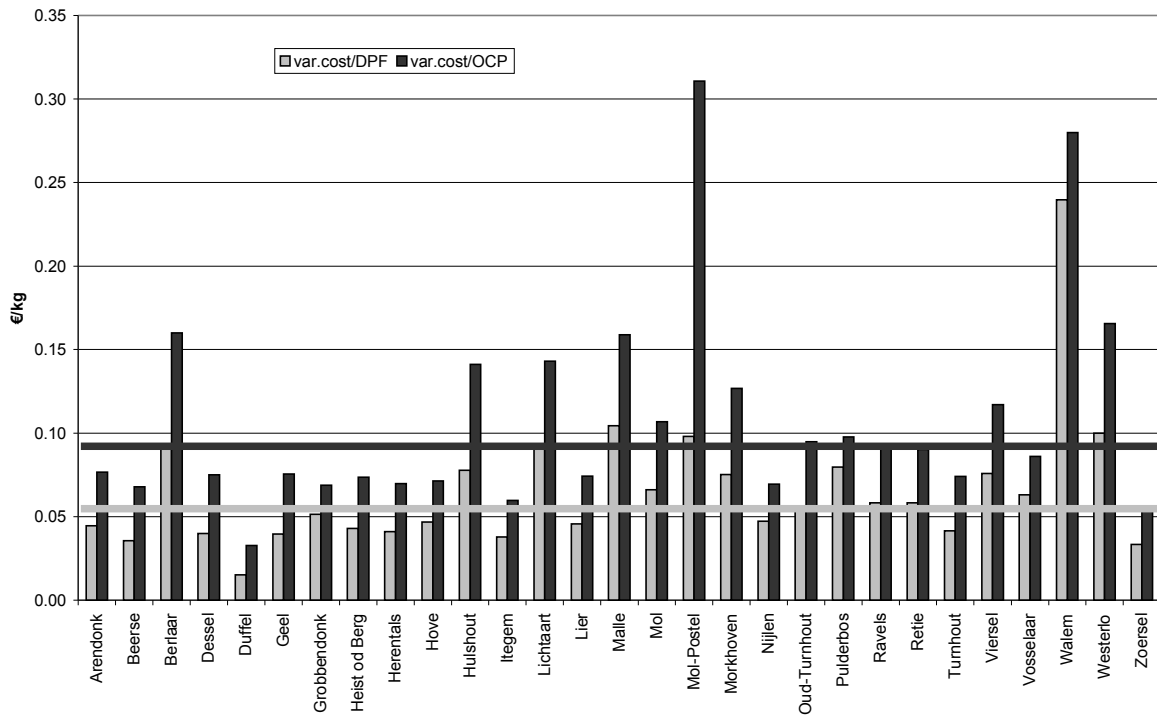

Figure 46: Variable costs specific to equivalent pollutant mass removed; horizontal lines show average values.

- e. *Costs per PE load.* Concerning the costs per PE (see Figure 47), the values are comparable to other similar studies, e.g. (Balmér, 2000; Bode and Grünebaum, 2000; Stemplewski *et al.*, 2001; Lindtner *et al.*, 2004). Note that costs here include both the plant and the main sewer network. As expected, for very small plants (<2,000PE) costs per PE are higher, especially for capital and staff expenditures, but no clear difference emerges when comparing the other two classes. This is probably due to the fact that all plants are anyway rather small, not exceeding 80,000PE in terms of design load. It is important to mention that the capital costs relative to the sewer works under the responsibility of municipalities (from households to the main collectors under the responsibility of Aquafin) were not included in this data analysis.
- f. *Energy consumption per volume of treated wastewater.* Figure 48 shows energy consumption specific to volume of treated wastewater. The average is weighed by the volume of wastewater treated by the plant. Lower values are associated to trickling filters and reed-beds, while higher values are found for low loaded oxidation ditches, reflecting the fact that most of the energy is consumed by the aeration process. For this indicator – as well as for indicators g) and i) – the average value is strongly influenced by the very similar conditions and performances of the biggest systems. Geel and Lichtart are the WWTPs (>20.000PE) which show the worst performance concerning this indicator.
- g. *WWTP plant footprint compared to wastewater treated* (see Figure 49). The average is weighted by the volume of wastewater treated by the plant. Higher values correspond to small-scale plants, especially reed-beds and lagoons, which are therefore often unsuitable for urban areas. Lower values correspond to large-scale plants, especially with the presence of primary clarifiers. Herentals, Pulderbos and Wosselaar show the largest footprint, excluding the very small WWTPs.
- h. *WWTP effluent concentration for pollutants.* All plants comply with the Flemish legislation on discharge concentrations. This respect for the environmental performance constraints makes the comparison of the plants on the basis of all the other indexes more consistent.
- i. *Infiltration water entering the sewer systems.* Results for infiltration (see Figure 36) were already shown and discussed in Chapter 5.
- j. *Stormwater discharged in the receiving water.* Results for CSOs (see Figure 37 and Figure 38) were already shown and discussed in Chapter 5.
- k. *Ratio of pollutants measured per pollutants discharged in the receiving water.* The ratios were calculated for COD, BOD, TN, TP and Zn, see Table 10. The values show good self-purification capacity of the river Nete, for which BOD is the major indicator, while COD is of course less degraded due to the limited retention time of the river. Concerning TP and Zn, the values higher than 1 might indicate an underestimation of the discharges in the river; possibly from agriculture for TP since the loads estimated to come from that source are the most uncertain, not being derived from measurements but from modelling using estimated data (manure application) as inputs; for Zn the cause might be that not all industry effluents are monitored.
- l. *Water quality indexes.* From Figure 50 (the Prati Index for Oxygen) it appears that oxygen levels are quite high in most headwaters except in the northern (densely populated) and southern areas of the basin and decrease downstream without reaching the worst quality class but in some intermediate stretches. Figure 51 (the Belgian Biotic Index) shows a

generally good situation, with exceptions in the most downstream area and in the north-west of the basin.

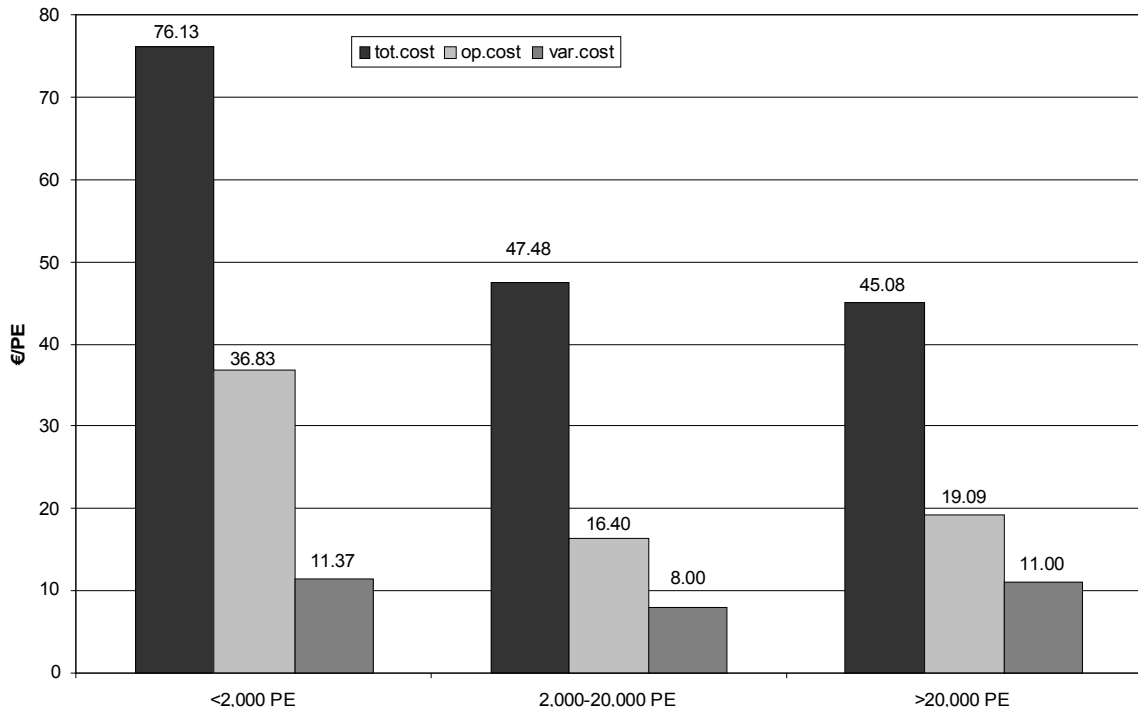

Figure 47: Costs in Euro per PE per year on the base of  $10\text{gTN}\cdot\text{inh}^{-1}\cdot\text{d}^{-1}$  for three classes of WWTPs.

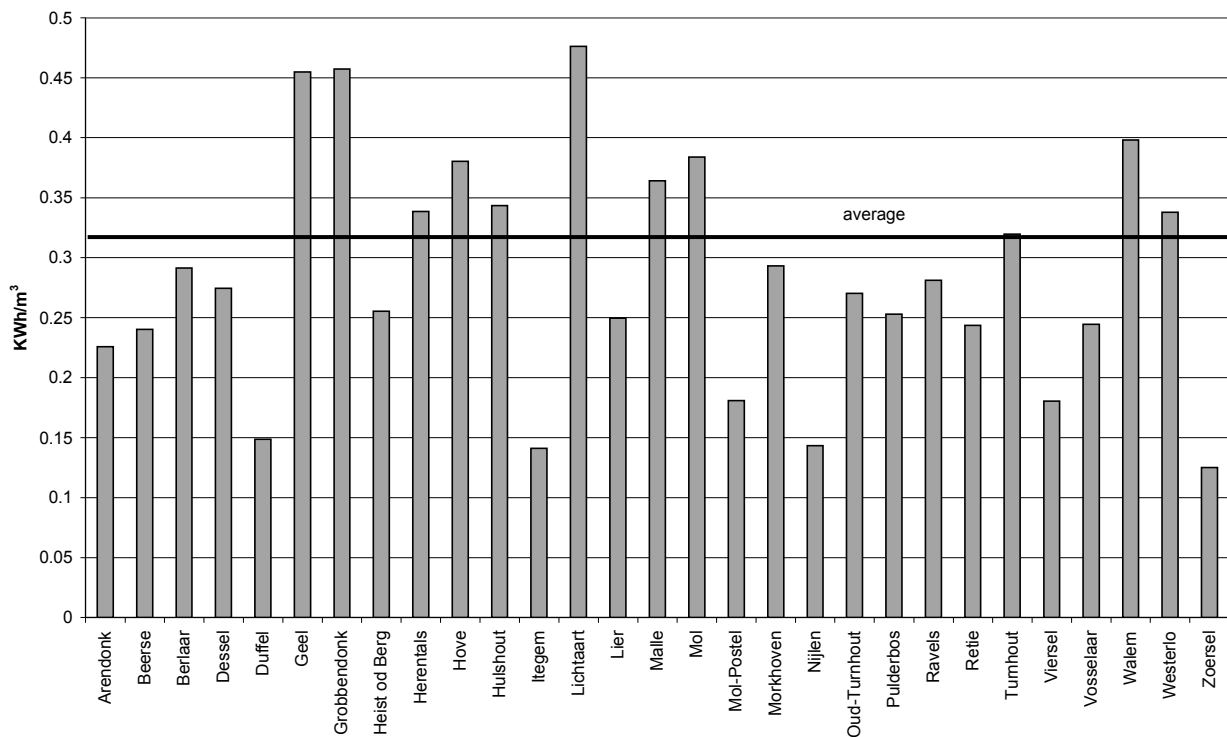

Figure 48: Energy consumption specific to volume of treated wastewater; averages are weighted by the plants' treated wastewater volume.

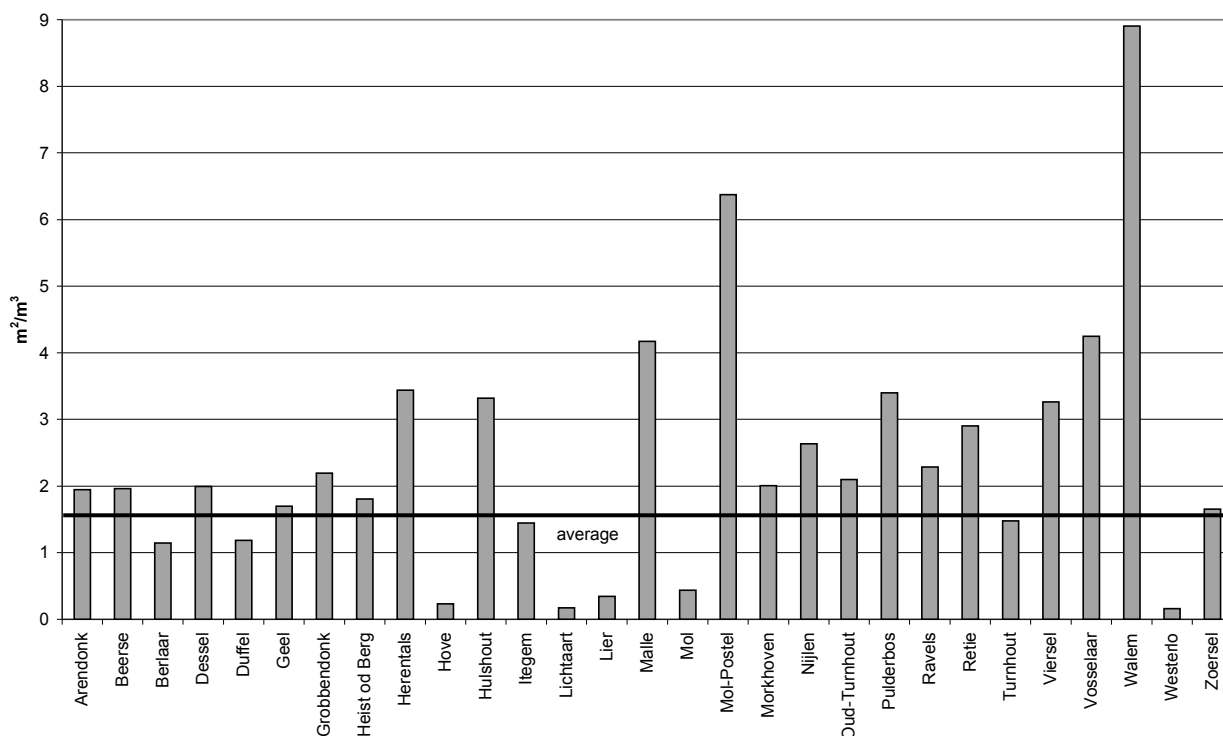

Figure 49: Footprint specific to volume of treated wastewater; averages are weighted by the plants' treated wastewater volume.

Table 10: Ratio of pollutants measured on pollutants discharged in the receiving water.

	COD	BOD	TN	TP	Zn
<b>measured concentration</b>	25.1 g·m <sup>-3</sup>	2.9 g·m <sup>-3</sup>	9.3 g·m <sup>-3</sup>	1.8 g·m <sup>-3</sup>	0.061 g·m <sup>-3</sup>
<b>loads/flow</b>	45.8 g·m <sup>-3</sup>	13.9 g·m <sup>-3</sup>	11.4 g·m <sup>-3</sup>	1.0 g·m <sup>-3</sup>	0.033 g·m <sup>-3</sup>
<b>ratio</b>	0.55	0.21	0.82	1.80	1.86

## 6.2.2 UNCERTAINTIES AND INFORMATION GAPS

Several uncertainties and information gaps have to be taken into account in this kind of studies. The most significant ones are the following:

- Some data come from estimations and other from measurements, making integration and comparison of data difficult; for example, the quantities entering the sewer system are estimated while its effluent is measured.
- Data for this study all correspond to the year 2002, except for households, for which data were available only from year 2001. The assumption has been made that no significant changes in the number of residents occurred from 2001 to 2002.
- The numbers of connected inhabitants are inconsistent: there are differences in the data provided by Aquafin and VMM.

- Small industries are not monitored since only major industries are obliged to self-monitor regularly and are on top of that occasionally monitored by VMM. In this study only major industries were considered.
- Septic tanks are very common in the Nete basin; they are present at approximately 50% of the households. Such treatment devices remove on average 35% of BOD by biodegradation, 20% of TP by adsorption and settling and 50% of COD by both mechanisms (Aquafin, personal communication); they are periodically emptied by trucks which bring the septic material to WWTPs with spare treatment capacity; in case the emptying frequency is not sufficient, the tanks overflow causing groundwater contamination and further reduction of load to the sewer system.
- Septic material delivered to the WWTPs was not included in calculations for loads and removals since no data were available for it.
- It was assumed that no transformations or removal occur to pollutants in the sewer network during transport from the source (households, industries) to the WWTP.
- Rainfall data was not available locally for the 29 sewer catchments, so the data available from 11 stations were averaged and used uniformly over the whole basin.
- Impervious areas were not always known with sufficient precision. Therefore, all calculations with respect to surface runoff are rather unreliable.
- CSO loads were not measured but roughly estimated; the main sources of error are: imprecise impervious area, presence of connected open ditches, high water level in the receiving water body leading to reverse flow into the sewers, infiltration.

Another aspect important when assessing the quality of the results is the scale at which some indicators are evaluated. Values of some indicators at sewer catchment scale are showing a large variability but the average values are within the range of values found in literature. This issue was already identified and discussed in Chapter 5.

### 6.3 Conclusions

Keeping in mind which difficulties were encountered when calculating the indicators due to the typical lack of data – introducing considerable uncertainties and giving relevance to the choice of the geographic scale of the study – it is still possible to identify the systems with higher improvement potential.

The indicators presented in this chapter allowed to identify the critical wastewater collection and treatment systems in the Nete river basin. In this case, with the receiving water quality being generally satisfactory and with all WWTPs respecting effluent limits, particular focus was given to the economic efficiency of the systems. Some plants clearly show room for improvement of their variable costs per unit of pollution removed (especially energy). Reduction of the pollution loads into the river can be obtained at reasonable costs by directing untreated wastewater to under-loaded plants.



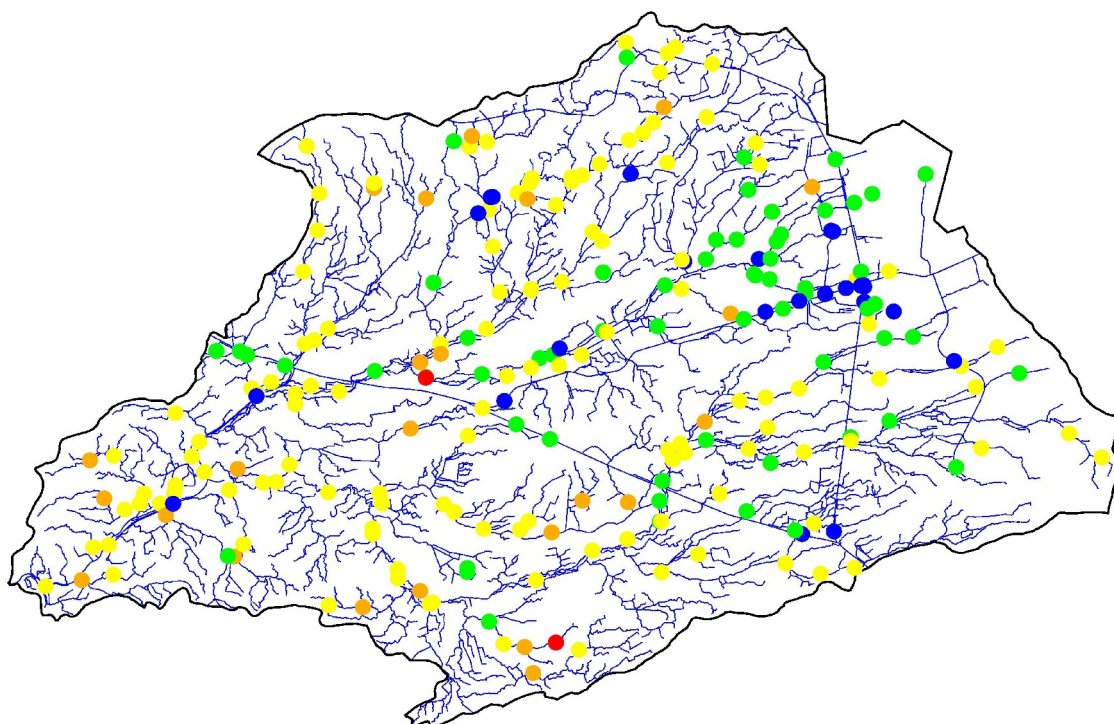

Figure 50: Prati index for oxygen (PIO) in the Nete basin in 2002; the index values are divided in five classes with increasing water quality: red, orange, yellow, green and blue.

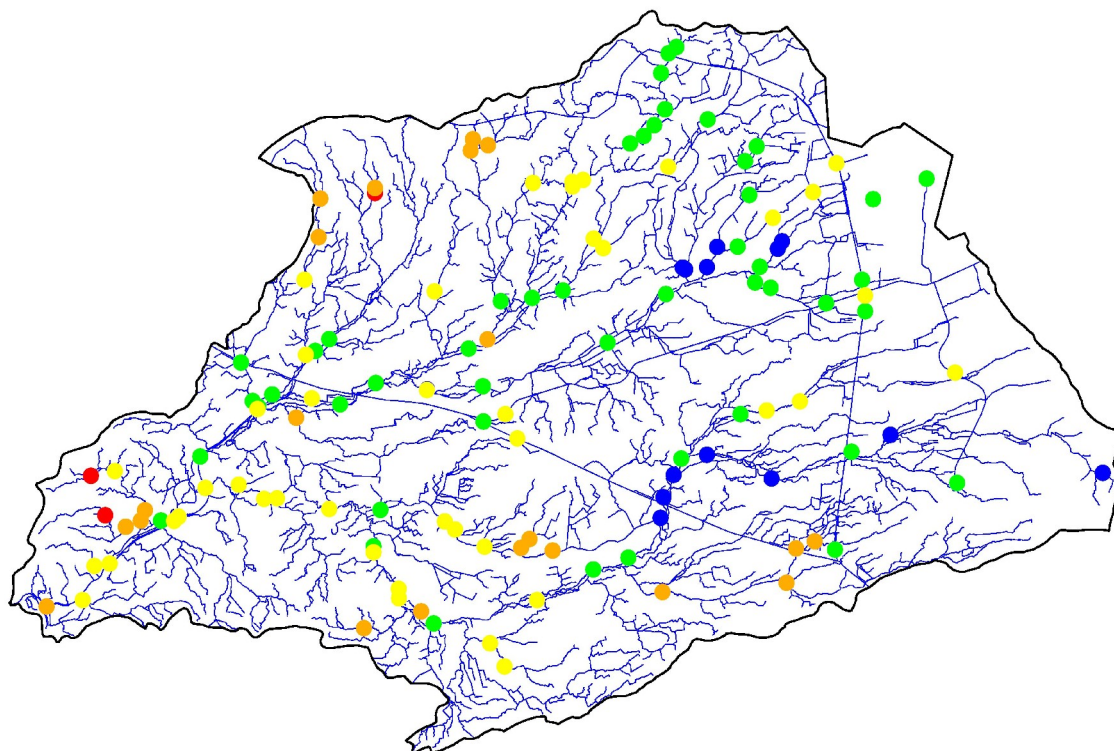

Figure 51: Belgian Biotic Index (BBI) in the Nete basin in 2002; the index values are divided in five classes with increasing water quality: red, orange, yellow, green and blue.



## **PART C**

### **HOW TO IMPROVE THE UWWS**



The European Water Framework Directive (WFD) requests to achieve good quality for ground and surface waters by organising water management on a river-basin scale and – with regard to impacts on natural water bodies originating from wastewater release – applying a combined emission and water quality based approach. There is therefore a need to evaluate and quantify what potential costs and benefits could result from the WFD approach, which is setting water quality goals in the natural water bodies instead of prescribing the design of urban wastewater systems. With this new water quality based approach, the design of the systems is by far less predetermined and the options to meet the goals become much more numerous. Therefore new design methodologies must be developed in order to be able to cope with such increased complexity.

This part of the thesis describes a new methodology to identify and quantify the costs and benefits for the development of the urban wastewater system resulting from the WFD approach, with regard to its environmental and economic consequences. Criteria to assess the environmental consequences are – besides the water quality – also secondary resource inputs such as energy, materials and chemicals.

The developed methodology is illustrated by a case of WWTP design and upgrade, with comparisons between several process options. Traditionally, treatment plants have been designed using empirical steady-state equations or “rules of thumb”, introducing conservative safety factors. Such approaches have led to the construction of over-dimensioned, expensive and not always properly functioning plants. It is recognised that traditional design procedures are not sufficient to produce WWTP designs which incorporate uncertainties about the boundary conditions influencing the plant performance (Dominguez and Gujer, 2006) To design or upgrade a treatment plant, deterministic models can be used, since their parameters have a straightforward physical meaning and can be directly measured in the system or applied to it (in case of obtained volumes, recycle rates, etc.).

The proposed methodology has been introduced in the General Introduction and is described in detail in this Part C of the dissertation.



## PRE-SELECTION OF ALTERNATIVES

*Parts of this chapter have been published as:*

*Vandenbergh, V., **Benedetti, L.** and Vanrolleghem, P.A. (2004). Synergetic use of the degrees of freedom to improve the urban wastewater system, In: Proceedings of IWA WWC 2004, Marrakech, Morocco, 19-24 September 2004.*

After having decided on a list of priorities by means of Systems Analysis (Part B of this dissertation) – with substance flow analysis and mass balances (Chapter 5) and with the evaluation of indicators (Chapter 6) –, the most critical technical sub-system (located in a certain catchment) is further considered to appropriately design the most suitable measure to improve the performance of the system. The first step in this process of Systems Design is the qualitative pre-selection of the alternative measures that can be implemented in the studied system (see Figure 52).

In every subsystem of the UWWS possibilities exist to improve the receiving water quality. In this context, those possibilities, the measures that can be taken, are called the “degrees of freedom” (DOFs). It is impossible to formulate and describe every possible action in detail, but several measures can be collected in more general descriptions of degrees of freedom.

A list with the most important DOFs is given in Table 11, corresponding to the database of alternative measures in Figure 52. A division is made according to subsystems. In the next chapters, only the options of WWTP design and upgrade are considered, as examples of measures that can be designed by dynamic modelling with probabilistic analysis of the performance.

The list of Table 11 is based on literature and experience of the technical partners involved in the CD4WC project. In order to focus on the most important measures, a priority list of DOFs was selected based on five criteria: compliance with new legislation; experience and acceptance; novelty; related costs (investment, operation and maintenance); easiness of measure implementation. Twenty-eight degrees of freedom were selected and they are marked in bold in

Table 11. They are described in detail and linked to case studies and literature in the deliverable D1.2 of the CD4WC project (CD4WC, 2004).

This qualitative evaluation of different measures can be a helpful tool in screening the different options and in the search for a measure that can solve the specific problem at hand. Once the most promising alternatives are selected by means of expert elicitation, they can be further evaluated by means of modelling their implementation and assessing their impact in the system under study (Blumensaat *et al.*, 2006a; Blumensaat *et al.*, 2006b).

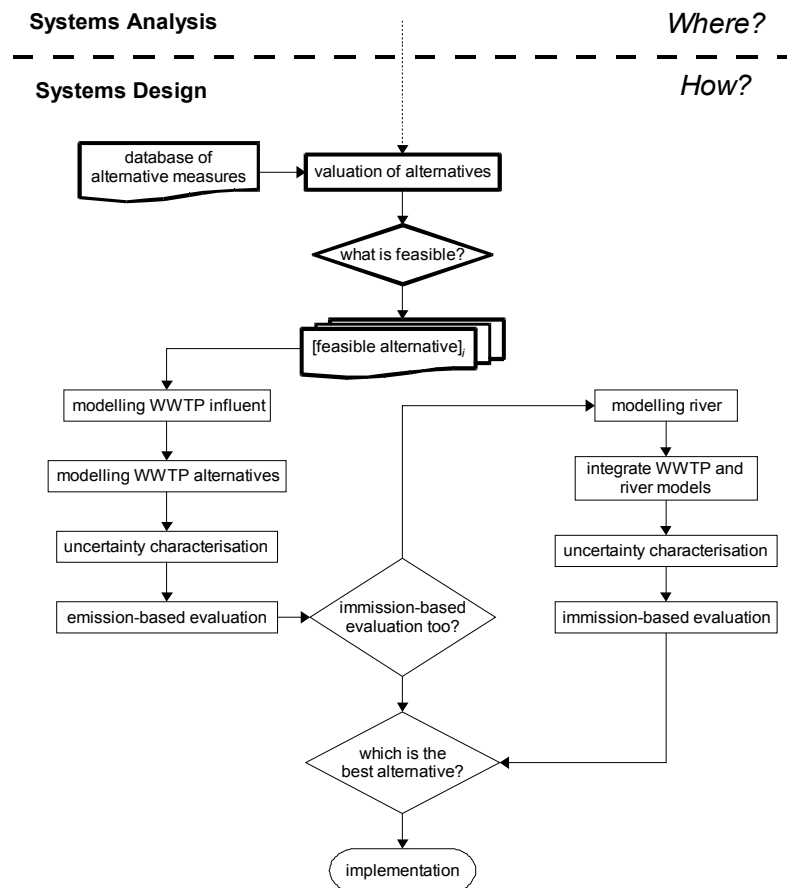

Figure 52: Pre-selection of alternatives within Systems Design.

Table 11: List with degrees of freedom for the urban wastewater system; in bold, the most important ones documented in CD4WC (2004).

Sub-system	Degree of freedom
Catchment	<b>Rainwater (stormwater) infiltration</b>
	<b>Toilet systems: dry, composting, vacuum and separation toilets</b>
	<b>Wastewater stream management: controlled discharge to the sewer, black water separation, yellow water separation, individual treatment</b>
	<b>Reduction of runoff</b>
	<b>Grey and rainwater reuse</b>
	Street cleaning



	Erosion control
	Placement of oil/waste-separators
	Nutrient management (e.g. phosphate substitute products)
	Measures to avoid metal emissions from roofs and gutters
	Measures in agriculture to avoid overfertilisation – change in cultivation strategy
	Decontamination of medium and highly endangered polluted areas
	Vacuum systems
	Anaerobic digestion systems
Sewer	<b>Reduction of in- and ex-filtration</b>
	<b>Methods of CSO storage/discharge/treatment</b>
	<b>Combined sewer overflow reduction: inflow reduction, sewer separation, control / maximisation of sewer storage capacity, pollution prevention</b>
	<b>Separate vs. combined systems, disconnection of industries</b>
	<b>Sediment management</b>
	<b>Real time control in the sewer system</b>
	<b>Retention tanks</b>
	Pond infiltration systems at Storm Sewer Systems
	Reduction of pipe clogging/pipe roughness due to ageing
	Decentralised solutions
	Change or eliminate discharge points
	Elimination of misconnections
	Chemicals use
Use of oversized pipes	
WWTP	<b>Optimisation of biological treatment processes: nitrogen removal, phosphorus removal, aerobic heterotrophic conversion of organic matter (aeration)</b>
	<b>Chemicals use in WWTPs: disinfection, chemical precipitation, dechlorination, dewatering and thickening, Fenton's reagent for oxidation</b>
	<b>Increase of WWTP loading</b>
	<b>Real time control of WWTPs</b>
	<b>New processes for wastewater treatment: the SHARON and Anammox processes, biological removal of hazardous chemicals at trace levels, upflow anaerobic sludge blanket granules, powdered activated carbon treatment / ultrafiltration, constructed wetland, sorption/anaerobic stabilisation treatment, membrane technology, bioaugmentation, enhanced primary settling</b>
	Effluent reuse
	Wastewater from industry: separate treatment vs. transport to existing WWTPs
	Cyclic treatment systems
	Natural treatment (reedbeds)
	Introducing new volumes
	Introducing different systems
	Anaerobic treatment
Receiving water	<b>Plants for natural bank reinforcement and shading</b>
	<b>Structural measures / meandering / bottom structure</b>
	<b>Base flow variation</b>

## Chapter 7 - Pre-selection of alternatives

	<b>Aeration</b>
	Dredging (polluted sediments)
	Structures to enable fish to overcome weirs, etc. and to travel upstream sluices
	Sedimentation areas
	Reroute receiving water around structures
Whole system	<b>Connection and extension of floodplains</b>
	<b>Integrated RTC</b>
	<b>Implementation of energy-efficient equipment</b>
	Energy load management
	Point sources allocation
	Education
	Material/substance substitution
	Energy production
Economic instruments	<b>Legal directives</b>
	<b>Charges or taxation</b>
	<b>Water pricing</b>
	<b>Tradable permits</b>
	Pollution trading

## MODELLING THE WWTP INFLUENT

*Parts of this chapter have been published as:*

*Devisscher, M., Ciacci, G., Fé, L., **Benedetti, L.**, Bixio, D., Thoeye, C., De Gueldre, G., Marsili-Libelli, S. and Vanrolleghem, P.A. (2006). Estimating costs and benefits of advanced control for wastewater treatment plants - the MAgIC methodology. *Water Science and Technology* 53(4-5), 215-223.*

*Gernaey, K., Rosen, C., **Benedetti, L.** and Jeppsson, U. (2005). Phenomenological modelling of wastewater treatment plant influent disturbance scenarios, In: *Proceedings of 10<sup>th</sup> International Conference on Urban Drainage (ICUD)*, Copenhagen, Denmark, 21-26 August 2005.*

Having decided that in a certain catchment a new WWTP has to be built or an existing WWTP has to be upgraded, the first step to adequately simulate the WWTP behaviour and effects, is to properly characterise the plant influent (see Figure 53).

A weak point in many simulation studies is the limited availability of long time series representing realistic dynamic influent disturbance scenarios. There is a necessity to have adequate influent time series because the natural diurnal, weekly and seasonal variations and episodic events (e.g. “first flush”) represent the main process disturbance (Jeppsson *et al.*, 2006).

In absence of these data, influent time series can be reconstructed, using available measurements and making assumptions on the influent properties (e.g. as in Bixio *et al.* (2002a) and in Devisscher *et al.* (2006)) or, in case of the absence of data, generated by a phenomenological model of the sewer catchment (Gernaey *et al.*, 2005a).

In this chapter, both approaches are presented and the influent characterisation used for the simulated scenarios is illustrated.

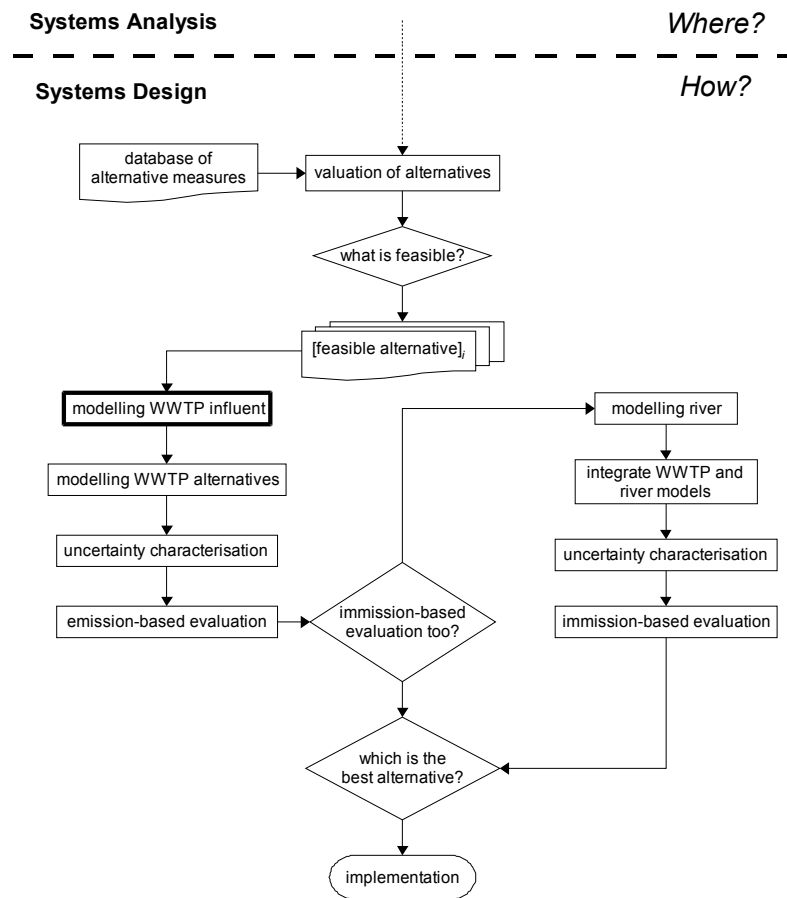

Figure 53: Modelling WWTP influent within Systems Design.

## 8.1 Tools

### 8.1.1 CASE WITH SOME DATA AVAILABLE

The aim was to provide an influent file for one year, with characteristics representative of reality, like a stochastic element, a daily pattern (two peaks), a weekly pattern (week-end effect), first-flush effect (identified by checking whether a rain event appears after a number of dry days or another rain day), dilution effect, a seasonal pattern.

If sufficient daily measured flow rate values are available, they are used directly and classified into dry and wet days (with flows larger than the 90<sup>th</sup> percentile they were assumed as wet days). Given the scarcity of water quality data, the pollutant load is computed from seasonal averages. A daily pattern is applied to the flow rate by means of a double sinus function – derived from the influent file of the EU COST-Action (Copp *et al.*, 2002) – and concentrations are calculated from load and flow rate. An example is shown in Figure 54.

If daily flow rate values are not available, they are generated from a Poisson distribution as a function of the season, after which the generated flow rate data undergo the same treatment as the

flow rate values taken from data.

This approach has been used to evaluate control strategies on existing WWTPs in Flanders (see Ciacci, 2004; Devisscher *et al.*, 2006).

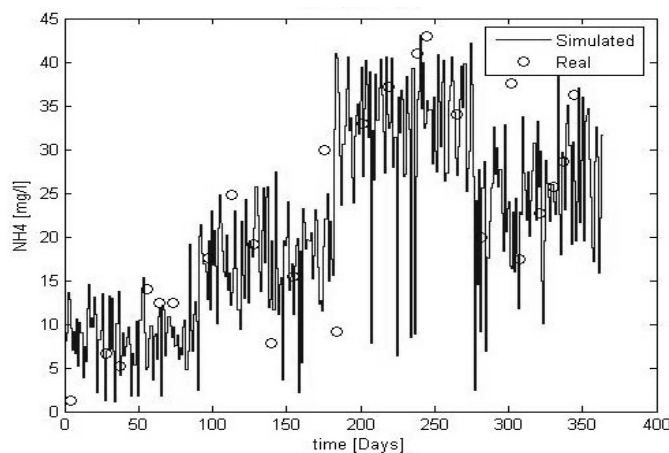

Figure 54: Example of a synthetically generated influent series and real data

### 8.1.2 CASE WITH NO DATA AVAILABLE

A simple phenomenological model was implemented, aimed at providing realistic WWTP influent dynamics without pretending at any point to provide a basis for studying urban drainage system mechanisms in detail.

Three basic modelling principles were applied:

1. model parsimony, limiting the number of model parameters as much as possible;
2. model transparency, for example by using model parameters that still have a physical meaning;
3. model flexibility, such that the proposed influent model can for example be extended easily for other applications where long influent time series are needed.

The proposed influent model produces dynamic influent flow rate and pollutant concentration trajectories. An example of the model structure relative to flow rate is shown in Figure 55.

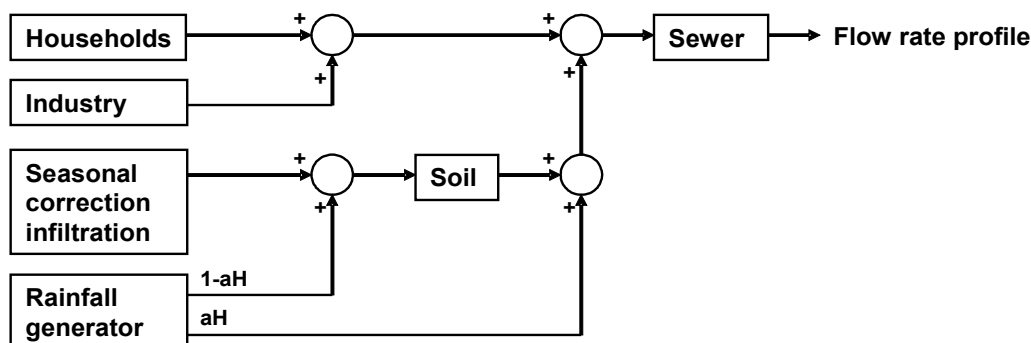

Figure 55: Schematic representation of the influent flow rate model;  $aH$  is the fraction of impervious surface.

Water flows are generated by adopting per capita discharges in households and industry (with daily, weekly and seasonal profiles), by rainfall-runoff on impervious surfaces connected to the sewer and by infiltration in the sewer from the soil compartment.

The soil is modelled as a variable volume tank with the level function of rainfall on pervious area and of an influent with seasonal variation representing the upstream aquifer. If the water level in the soil tank is higher than the invert level at which the sewer is placed, infiltration occurs at a rate function of such water level.

Rainfall can be either given as measured data (input file) or generated by a simple rainfall model.

The sewer is modelled as a series of tanks with variable volume. The size of the sewer system can be selected, assuming that a relatively small sewer system will result in sharp diurnal concentration peaks, whereas a large sewer system will result in smooth diurnal concentration variations.

The example given in Figure 56 shows how that effect is achieved. In case of very small sewer networks, all the inflow passes only through the line with one block (each block consists of three tanks in series), while with a large sewer network the inflow will be evenly distributed to the four parallel lines. The model actually allows to choose to have up to eight parallel lines.

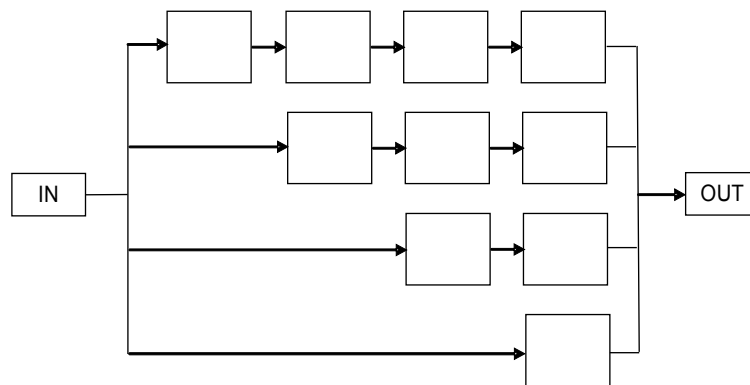

Figure 56: Schematic representation of the sewer model.

As inputs, the model requires *per capita* discharges in households and industry (with daily and weekly variations) for:

- water;
- soluble COD;
- particulate COD;
- total Kjeldahl nitrogen;
- total phosphorous.

The same variables are generated as output of the model.

Sedimentation and resuspension equations are included in the sewer model, to obtain a “first flush” effect under the appropriate conditions.

Stormwater pollution was not included in the model, as a simplifying assumption.

Noise is added to all generated quantities in order to reproduce the variability of the phenomena.

The model was implemented in the Matlab/Simulink platform. The production of a yearly

influent file with data every 15 minutes for a system with large a sewer network takes less than 5 minutes on a Pentium 4 machine with a 3GHz processor.

For a full description of this dynamic influent generation model, see Gernaey *et al.* (2005b).

## 8.2 Scenarios

For this study, no influent data were available. Therefore the WWTP influent had to be generated with the phenomenological model.

The natural variability of WWTP influents in space was explored by selecting four different climatic conditions for catchments representative of European situations. The four climates are:

- Alpine
- Continental
- Mediterranean
- Oceanic

The four influent types vary according to:

- rainfall data (real rainfall data collected at rain gauges belonging to the climatic area with high frequency, e.g. 5 minutes, see Figure 57 and Table 12);
- water temperature (e.g. colder for Alpine area and warmer for Mediterranean area, daily values, see Figure 58);
- slope of the catchment (e.g. steep for Alpine area and flat for Oceanic area).

All other potential sources of differences were neglected in order to make the comparison of processes more feasible.

This approach would help in stressing how different boundary conditions (rainfall, temperature and slope) affect the performance of treatment processes.

The variability in time is assumed to be captured by generating one-year time series with data every 15 minutes. The measured temperature and rainfall data required by the model should come from a representative year for the specific climate. The four locations and years taken as representative for the climates were:

- Innsbruck 2003 (Alpine)
- Dresden 2000 (Continental)
- Palermo 1996 (Mediterranean)
- Brussels 1982 (Oceanic)

Three catchment sizes, considered as representative sizes for treatment plants in Europe, have been chosen:

- 3,000 PE
- 30,000 PE
- 300,000 PE

Therefore, a total of  $4 \times 3 = 12$  combinations of climate and size were used to test the performance of the process alternatives for design.

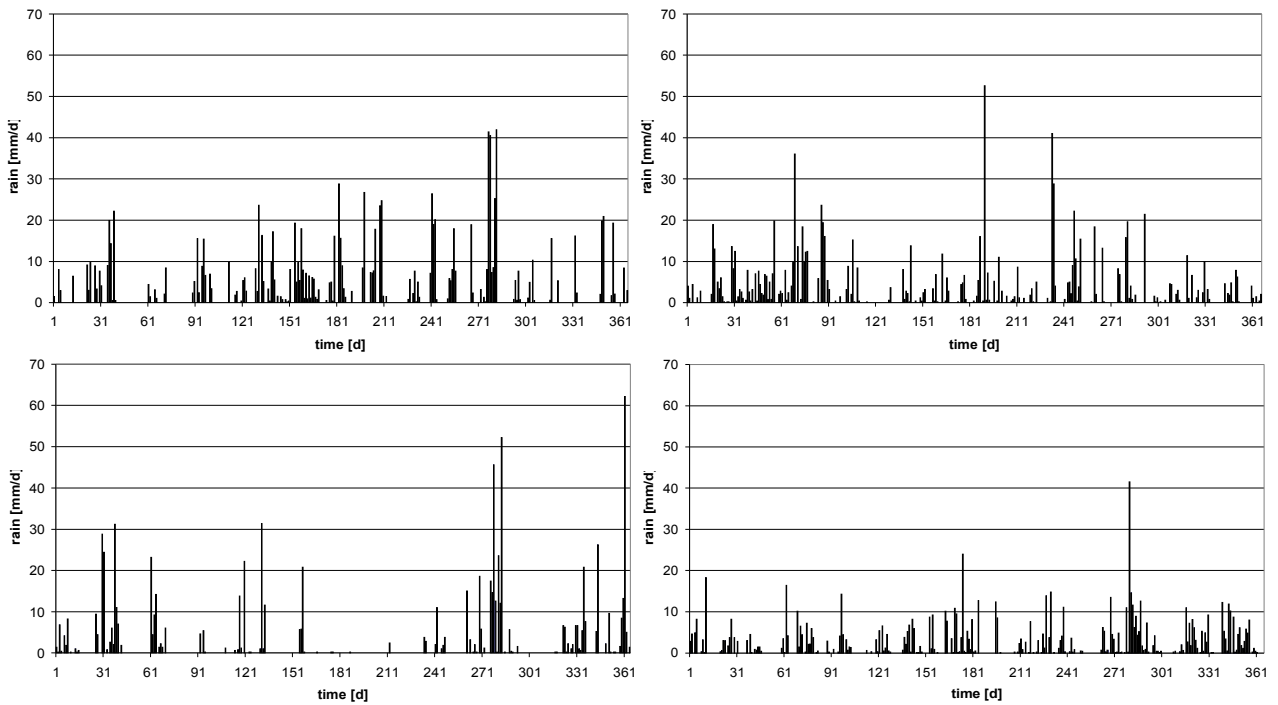

Figure 57: One year time series of rainfall (January to December); from left to right and from top to bottom: Alpine, Continental, Mediterranean and Oceanic climate.

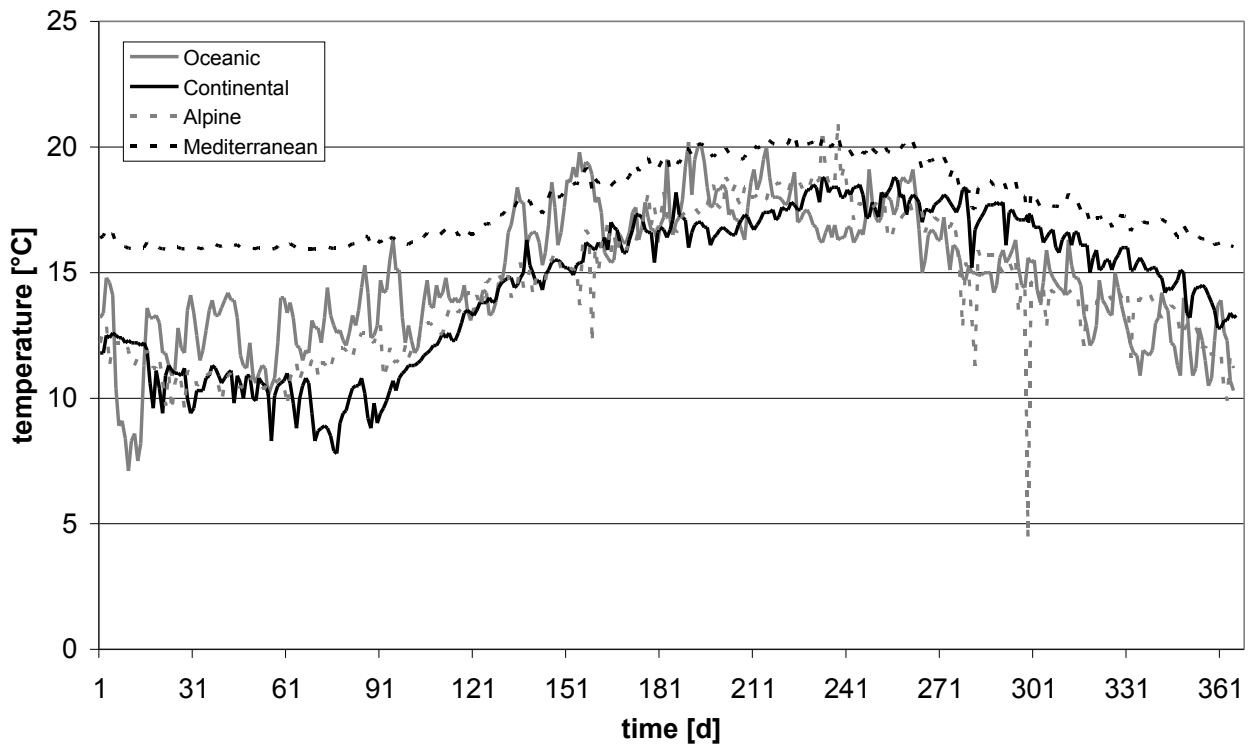

Figure 58: Influent water temperature profile for the four climates (January to December).



Table 12: Year for data series and total rainfall in that year for the four climates.

climate	Alpine	Continental	Mediterranean	Oceanic
year	2003	2000	1996	1982
rainfall [mm/y]	1154	1015	809	801

In case of upgrade, only the combinations of the largest size with Continental and Mediterranean climates have been considered. The necessity of upgrading was given by an assumed increase in catchment size and population connected from 300,000PE to 400,000PE.

The influent generator model requires a set of inputs (provided by Aquafin as personal communication, except for rainfall), among which the more important are:

- rainfall measurements (see Figure 57);
- average loads for households and industry (see Table 13 from Aquafin, personal communication); for households, different values from Table 3 were used since in Table 13 the values refer to WWTP influent data because no degradation occurs in the sewer system model, while Table 3 refers to values at source.
- daily, weekly and yearly dynamic patterns for households (see Figure 59 to Figure 62);
- weekly and yearly dynamic patterns for industry (see Figure 61 and Figure 63).

Concerning the weekly and yearly pattern, assumptions have been made on the main vocation of urbanisations on the base of climate and size, as shown in Table 14. According to Table 14, the assumed weekly and yearly patterns applied to the household loads are presented in Figure 60 and Figure 62 respectively.

Concerning industry, it has been assumed that it is absent for 3,000PE, it consists of small industries closing during holidays for 30,000PE and of a mixture of small and large industries (not closing during holidays) for 300,000PE. The weekly patterns (see Figure 61) are the same for both 30,000 and 300,000PE. The yearly patterns (see Figure 63) have been created considering a bigger fraction of smaller factories for 30,000PE and of larger factories (working also in summer) for 300,000PE.

Patterns with different time scales (daily, weekly, yearly) are multiplied to obtain the overall pattern.

In order to fully capture the effect of low temperature on nitrification, the evaluation period was set to start the 1<sup>st</sup> of July and finish the 30<sup>th</sup> of June to include the winter period until complete nitrification capacity recovery. The one-year evaluation period is preceded by 50 days of dynamic influent to have the processes and especially controllers (when present in the configuration) completely accustomed to dynamic conditions. A first period of 50 days with steady state input were added to reach steady state in the processes. Therefore, the total simulation period for every configuration evaluated is 50 days with steady state input plus 415 days with dynamic input.

Table 13: Average loads for households and industry.

Parameter	Value	Description
Q hh [l/d/PE]	150	water per PE per day for households
CODs hh [gCOD/d/PE]	30	soluble COD per PE per day for households
CODp hh [gCOD/d/PE]	70	particulate COD per PE per day for households
TKN hh [gN/d/PE]	11	TKN per PE per day for households
TP hh [gP/d/PE]	1.8	TP per PE per day for households
Q ind [l/d/PE]	15	water per PE per day for industry
CODs ind [gCOD/d/PE]	30	soluble COD per PE per day for industry
CODp ind [gCOD/d/PE]	70	particulate COD per PE per day for industry
TKN ind [gN/d/PE]	4.4	TKN per PE per day for industry
TP ind [gP/d/PE]	0.72	TP per PE per day for industry
ind/hh [%]	15	percentage of industrial load based on COD
inf [%]	30	percentage of infiltration based on dry weather flow

Table 14: Assumed vocation of urbanisations.

	Alpine	Continental	Mediterranean	Oceanic
3,000 PE	tourism	agriculture	tourism	tourism
30,000 PE	tourism	agriculture	tourism	suburb
300,000 PE	city	city	city	city

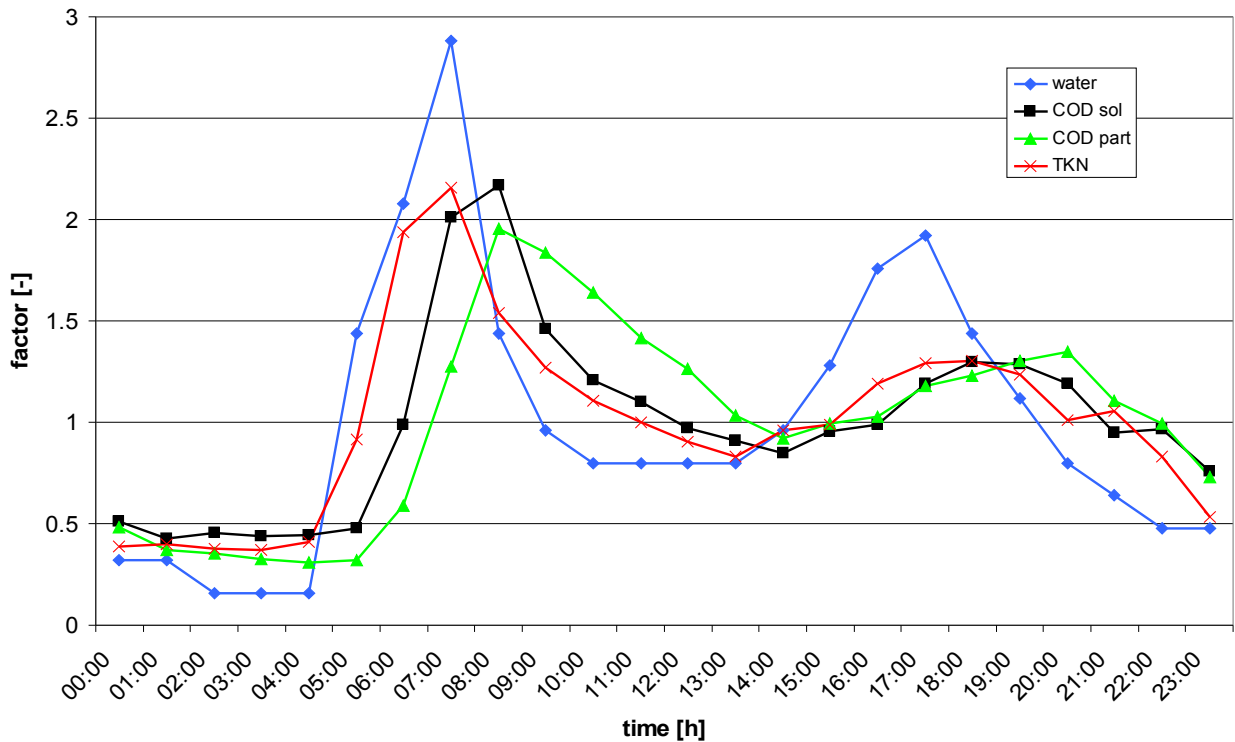

Figure 59: Daily dynamic load patterns for households; TP is assumed to have the same pattern as particulate COD.

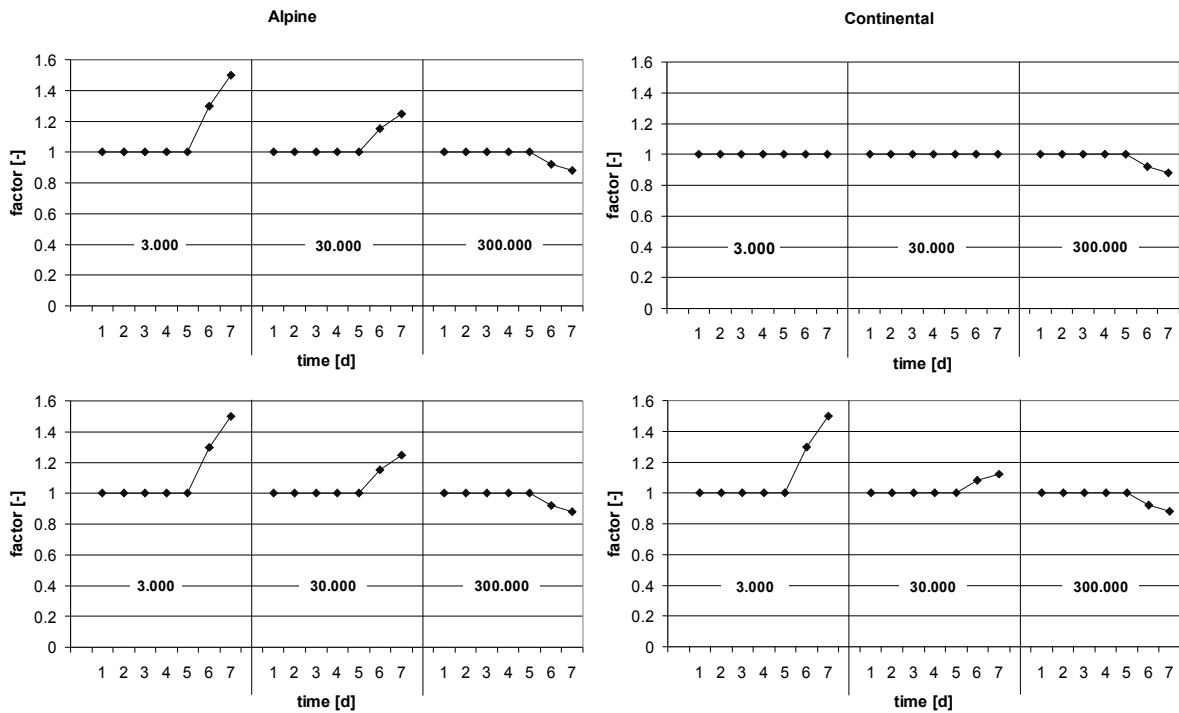

Figure 60: Weekly patterns for household loads (Monday to Sunday); from left to right and from top to bottom: Alpine, Continental, Mediterranean and Oceanic climate.

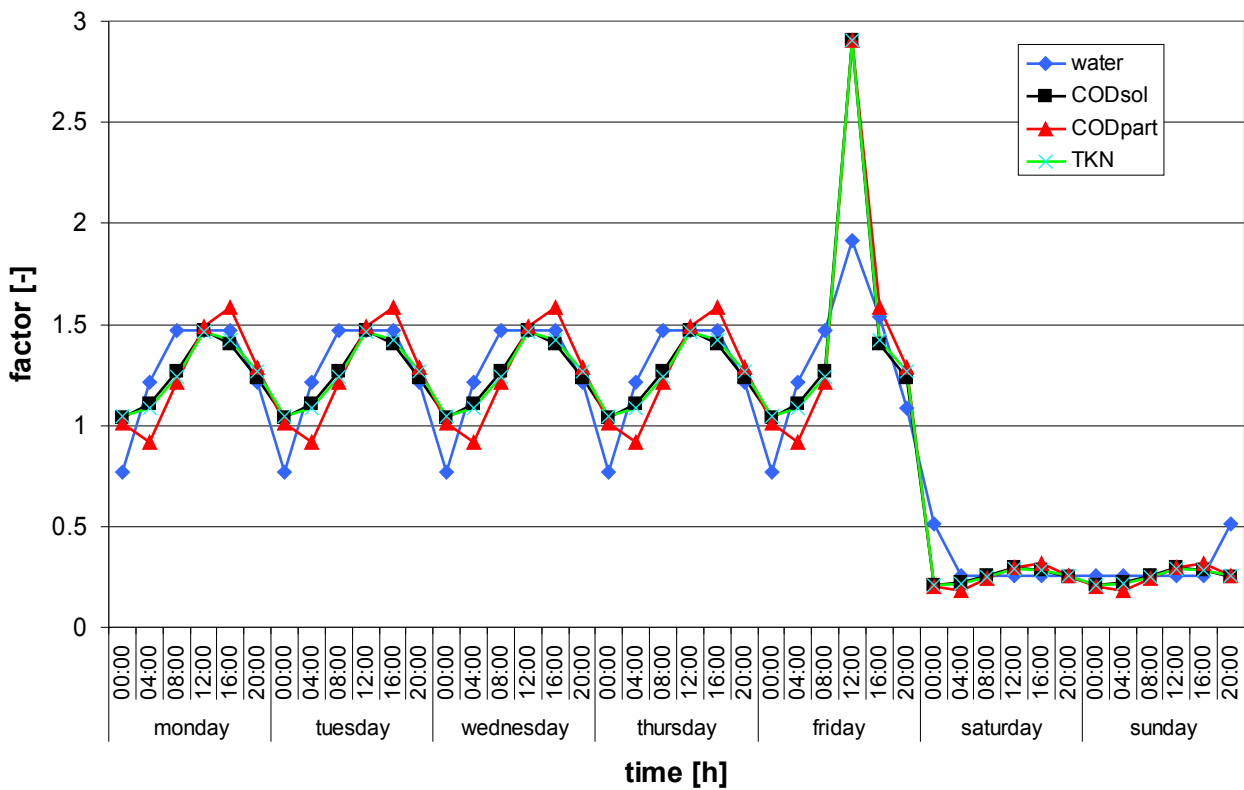

Figure 61: Weekly dynamic load patterns for industry.

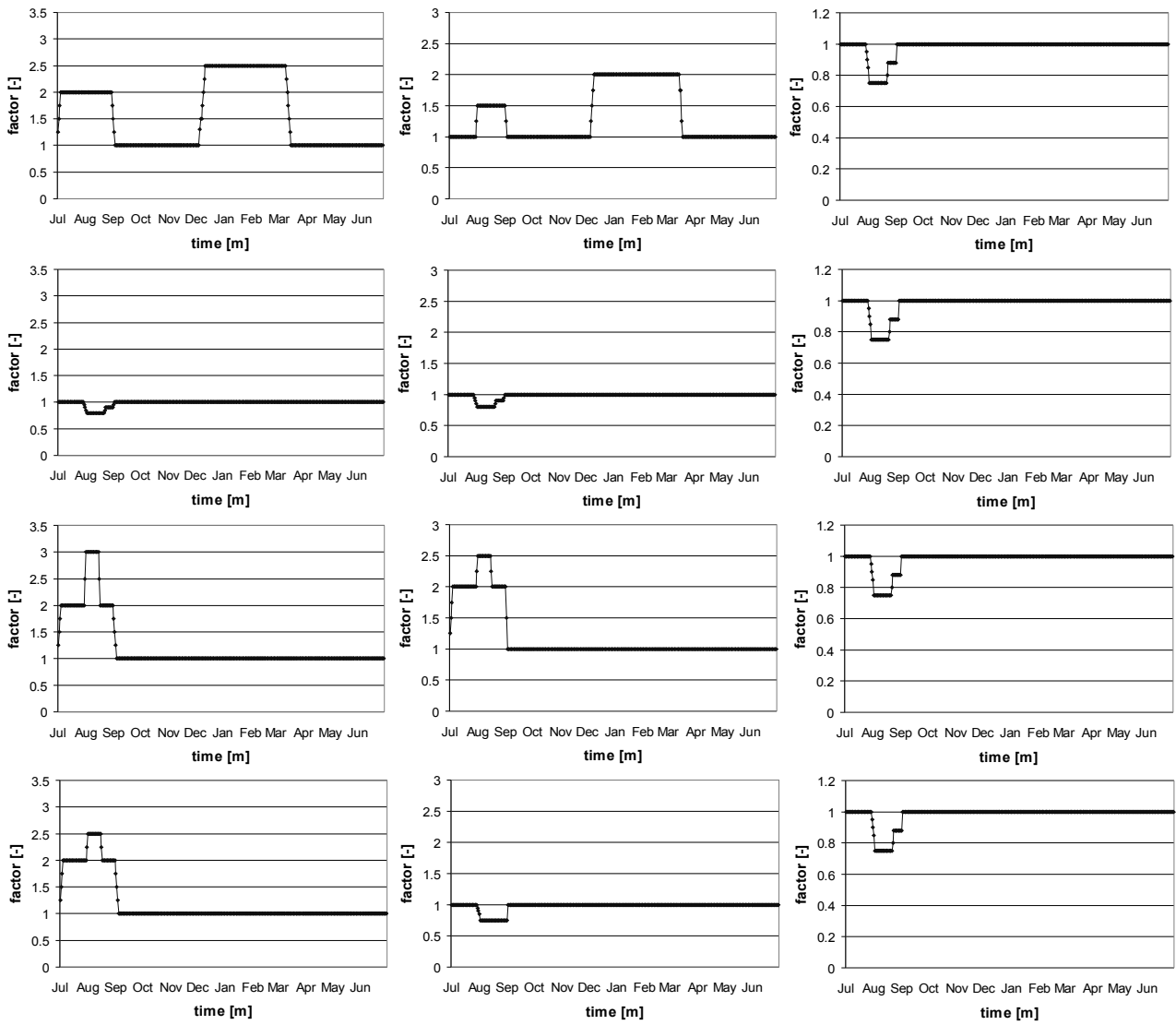

Figure 62: Yearly patterns for household loads (July to June); top to bottom Alpine/Continental/Mediterranean/Oceanic, left to right 3,000PE/30,000PE/300,000PE.

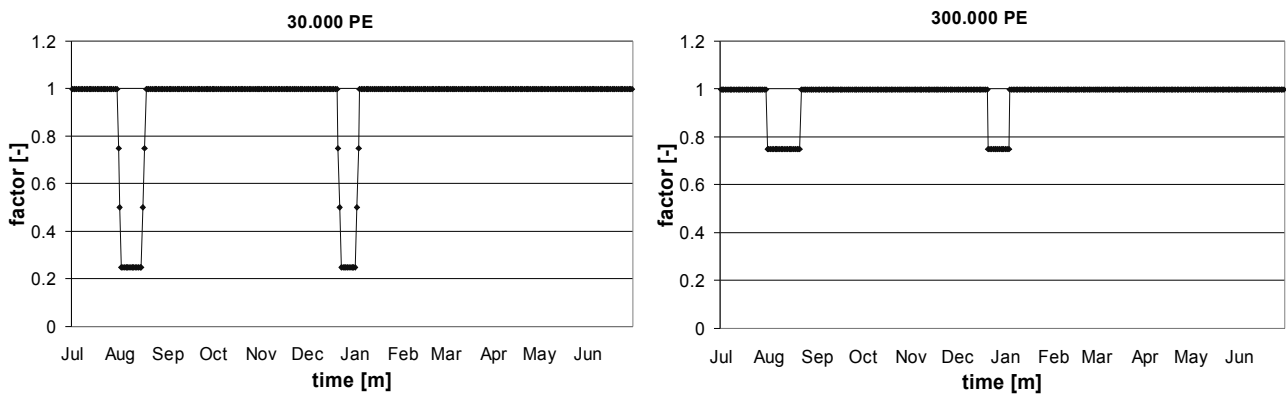

Figure 63: Yearly dynamic patterns for industry (July to June).

## 8.3 Conclusions

In this chapter two approaches to generate long-term dynamic WWTP influent data have been presented, one for cases with some data available and one for cases without data available, both implemented in Matlab/Simulink. The latter approach has been used in this work to produce the influent for the simulated scenarios of WWTP design and upgrade. Households and industrial discharges have been characterised for three catchment sizes, as well as four different climate conditions representative for Europe, defining a total of twelve different combinations of size and climate, constituting the input data for the simulated scenarios.



## MODELLING WWTP ALTERNATIVES

*Parts of this chapter has been published as:*

*Claeys, F., De Pauw, D.J.W., **Benedetti, L.** and Vanrolleghem, P.A. (2006). Tornado: A versatile and efficient modeling & virtual experimentation kernel for water quality systems, In: Proceedings of iEMSs 2006, Burlington, VT, USA, 10-13 July 2006.*

After having obtained the WWTP input data, the WWTP process configurations have to be dimensioned and implemented in a modelling and simulation software (see Figure 64).

In the case of a renovation or upgrade, relevant information how to build and calibrate these models is often available, e.g. influent and process data. For such situations, calibration methodologies (Sin *et al.*, 2005) can be found in a large number of publications, e.g. among the most comprehensive (Hulsbeek *et al.*, 2002; Langergraber *et al.*, 2003; Melcer *et al.*, 2003; Vanrolleghem *et al.*, 2003). This calibration should be performed by experienced modellers to limit the possibility of misinterpretation of the model results. After having obtained a calibrated model of the plant, several upgrade options can be implemented by modifying and/or extending the plant configuration, by increasing or adding volumes, modifying flow paths, adding or changing processes, etc.

In the case of a design (i.e. no infrastructure is in place yet), standard parameter values should be applied for the used models, while operational variables are decided by the modeller and optimal values for them will be identified by performing several simulations with different values, or applying an optimisation algorithm. In this case there is no calibration of the model to be performed, but only some adjustments to parameter values; e.g. if for any reason (temperature, influent characteristics, etc.) the expected Sludge Volume Index is higher than average, some parameters in the secondary settling model should be modified. An alternative to the use of modelling using default parameters is the use of a pilot plant. The analysis of uncertainty should improve the confidence in the model, which remains an approximation of reality.

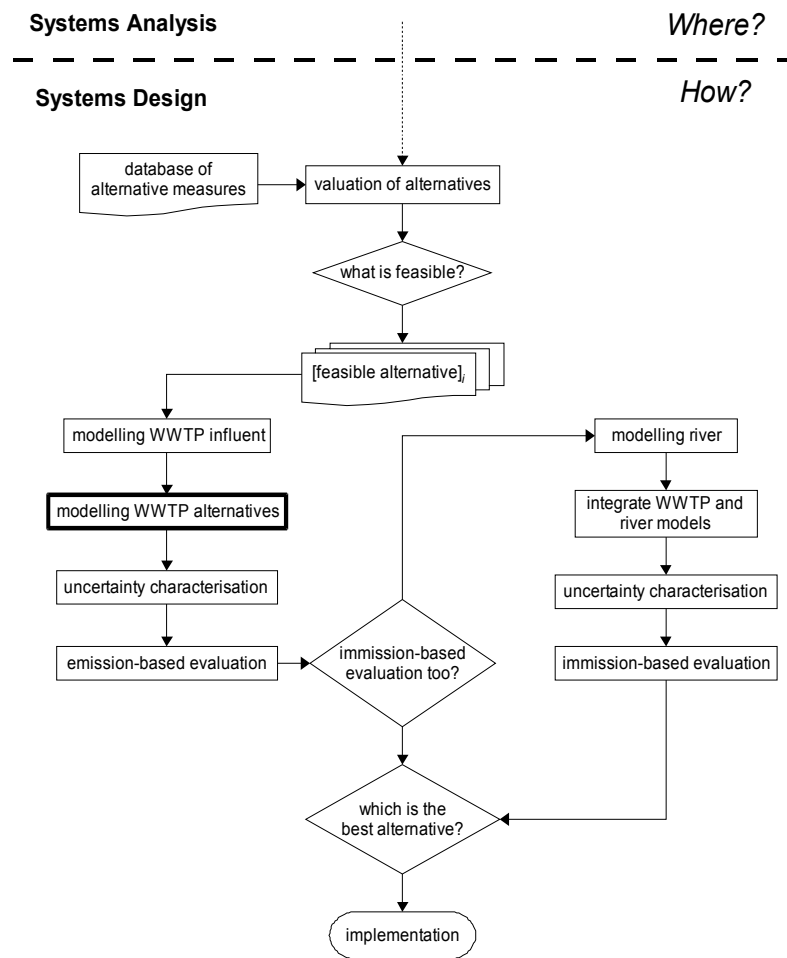

Figure 64: Modelling WWTP alternatives within Systems Design.

## 9.1 Tools

### 9.1.1 WWTP MODELS

For the activated sludge units (aerobic, anoxic and anaerobic tanks), ASM2d (Henze *et al.*, 2000) was chosen, in its modified version which takes into account different values for the decay rates of biomass according to the electron acceptor in the tank (Gernaey *et al.*, 2004a); see Table 15 for the decay rate modifications in purely aerobic, anoxic and anaerobic conditions. This model is applied in all the process configurations tested, even the ones not removing phosphorous, since it was easier to perform a thorough comparison of effluent quality.

The parameters most sensitive to temperature were considered as temperature-dependent according to the following equation:

$$P_T = P_{T_{ref}} \cdot \theta_P^{(T-T_{ref})}$$

where  $P_T$  is the value of parameter  $P$  at temperature  $T$ ,  $P_{T_{ref}}$  is the value of parameter  $P$  at the



reference temperature  $T_{ref}$  (20°C) and  $\theta_P$  is the temperature correction factor for parameter  $P$ . The temperature-dependent parameters and their associated temperature correction factors are listed in Table 16 and are derived from Henze *et al.* (2000).

Also the concentration of dissolved oxygen at saturation ( $DO_{sat}$ ) was calculated as a function of temperature as follows (Bowie *et al.*, 1985):

$$DO_{sat} [^\circ\text{C}] = 14.65 - 0.41022 \cdot T + 0.007991 \cdot T^2 - 0.000077774 \cdot T^3$$

Table 15: ASM2d decay process rate modifications in purely aerobic, anoxic and anaerobic conditions (adapted from Gernaey *et al.*, 2004a).

Process	Decay rate		
	Aerobic	Anoxic	Anaerobic
Decay of heterotrophs	$b_H$	$0.5 \cdot b_H$	0
Decay of PAOs	$b_{PAO}$	$0.33 \cdot b_{PAO}$	0
Decay of PP	$b_{PP}$	$0.33 \cdot b_{PP}$	0
Decay of PHA	$b_{PHA}$	$0.33 \cdot b_{PHA}$	0
Decay of autotrophs	$b_A$	$0.33 \cdot b_A$	0

Table 16: Temperature-dependent parameters and their associated temperature correction factors  $\theta$ .

Parameter	Description	$\theta$
$\mu_H$	Maximum heterotrophic growth rate	1.072
$b_H$	Rate constant for heterotrophic lysis and decay	1.072
$\mu_{PAO}$	Maximum growth rate of PAOs	1.041
$b_{PAO}$	Rate constant for lysis and decay of PAOs	1.072
$\mu_{AUT}$	Maximum autotrophic growth rate	1.111
$b_{AUT}$	Rate constant for autotrophic lysis and decay	1.116
$Q_{PHA}$	Rate constant for storage of PHA	1.041
$b_{PHA}$	Rate constant for lysis of PHA	1.072
$Q_{PP}$	Rate constant for storage of PP	1.041
$b_{PP}$	Rate constant for lysis of PP	1.072
$k_h$	Hydrolysis rate constant	1.041
$K_X$	Saturation coefficient for particulate COD	0.896
$Q_{fe}$	Maximum rate for fermentation	1.072

A heat balance model in the WWTP was added, based on the work of Gillot and Vanrolleghem (2003), to calculate the temperature in the tanks as function of incoming water and ambient air temperature, tank characteristics and aeration intensity, applying the default parameters. The completely mixed hypothesis supposes that the water temperature is uniform over the basin and equals the outlet temperature. The energy balance over the reactor implies that the net heat exchange (see Figure 65) equals the enthalpy change between the influent and the effluent streams. The model actually implemented neglects the contributions of  $H_b$  and  $H_{tw}$  since they are deemed to be of minor relative importance (Gillot and Vanrolleghem, 2003).

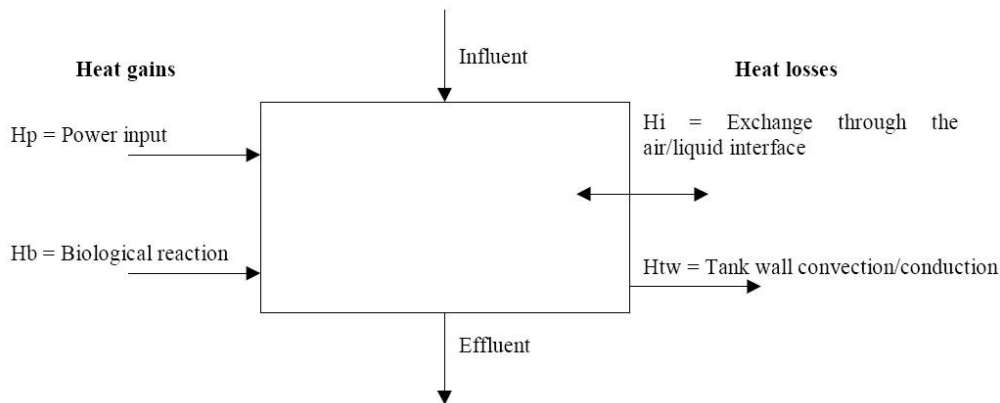

Figure 65: Overview of the heat exchanges over the basin.

For the primary settlers (where present) the model of Otterpohl and Freund (1992) was used with its standard parameter values.

The model of Takacs *et al.* (1991) was adopted for the secondary settlers, with a modification to express the settling characteristics as a function of the sludge volume index (SVI) as modelled by Daigger and Roper (1985), with standard parameter values and assuming an SVI of 100mL/g.

### 9.1.2 SIMULATION SOFTWARE - WEST AND TORNADO

A new modelling and virtual experimentation kernel for water quality systems has been developed in order to be able to cope with the large computational load implied by the one-year simulations of complex WWTP layouts. This kernel was named “Tornado” and will be included in the new generation of the WEST product family (HEMMIS, Kortrijk, Belgium), as well as in several other products and projects. Most important issues during development were versatility and efficiency. It is argued that classical approaches such as the adoption of Matlab/Simulink, custom FORTRAN codes and/or domain-specific simulators all have specific disadvantages. Therefore, a need arose for a kernel that offers a compromise between versatility and efficiency.

Tornado was developed in C++ using advanced language features, yielding a code base that offers fast execution, portability and increased readability. The software is composed of strictly separated environments for modelling and virtual experimentation. The modelling environment allows for the specification of complex ODE and DAE models in object-oriented, declarative languages such as MSL (Vanhooren *et al.*, 2003) and Modelica. A model compiler translates these high-level models into efficient, flattened code. The experimentation environment allows for running single virtual experiments (such as simulations and steady-state analyses) as well as compound experiments (optimizations, scenario analyses, etc.) on the basis of flattened models.

Details on Tornado can be found in Claeys *et al.* (2006b).

As an example of the improved performance: a WWTP model, running for 50 days in steady state and 415 days in dynamic conditions, with input and output data every 15 minutes, required only 31 minutes to execute on a Pentium 4 machine with a 3GHz processor. Using state of the art commercial software (WEST version 3.7.2), it took 140 minutes. The solver used for the integration was the Runge-Kutta solver with variable step.

Tornado is now already included in WEST 3.7.3 as a batch simulator and will be fully incorporated in a new version of WEST.

Still the WEST software was used to build the process configurations and experiments, since it has a powerful graphical user interface which allows easy model development, configuration building and experiment set-up. The obtained configurations and experiments were then translated into files readable by Tornado, by means of *ad hoc* scripts.

WEST (Vanhooren *et al.*, 2003) is a versatile yet powerful modelling and simulation system, which so far has mainly been applied to water quality management. The system consists of a clearly separated Modelling Environment and Experimentation Environment. Both environments are self-contained and consist of a graphical front-end, a computational back-end and control logic. The Modelling Environment allows for the creation of executable models on the basis of high-level model descriptions, through the application of model compiler techniques. These executable models are subsequently used as a basis for the creation of virtual experiments (VEs) in the Experimentation Environment. The reason why the term “VE” was adopted is related to the fact that WEST goes beyond plain simulation. In fact, the types of VEs that are currently supported are: Simulation, Steady-state Analysis, Parameter Estimation, Confidence Analysis, Scenario Analysis, Sensitivity Analysis and Uncertainty Analysis.

## 9.2 Scenarios

### 9.2.1 WWTP DESIGN

#### Process configurations and general layout

For this study, 10 process configurations have been selected to represent the most common plant layouts in Europe (see Table 17). A detailed description of the 10 processes can be found in Appendix A, including illustration of the process layout in WEST and a description of the configurations' characteristics for operation.

In all plant layouts (see a general layout implemented in WEST in Figure 66, with legend in Table 18) the influent is first transformed (block "T") from the output variables of the influent generator model (soluble and particulate COD, TKN and TP) to ASM2d state variables (see Appendix B). Then the concentrations and flow rate are combined into mass fluxes (block "CF\_in").

Before entering the plant, the flow exceeding 5 times dry weather flow (DWF) is diverted out of the system by the block “CSO”, representing a combined sewer overflow. Then, the flow exceeding 2.5 DWF is diverted to the storm tank which is modelled by an ideal separator (block “st\_treatment”) and its corresponding volume (block “st\_volume”) whose pump is regulated by the flow sensor

“s\_array\_in” and by the controller “c\_buffer” in order not to exceed a pumped volume of 2.5 DWF. The same blocks also regulate the flow splitter “sp\_bp” in a way that the flow coming out of “cm\_rec\_bp” never exceeds 2.5 DWF. The underflow of the storm tank leaves the system and is not considered for further data treatment since it is constant for all process configurations.

Table 17: Plant configurations tested for WWTP design.

Short name	Long name	Description
A2O	anaerobic-anoxic-oxic	low loaded system, performs biological N and P removal
AO	anaerobic-oxic	high loaded system, performs biological P removal
BDNP	Biodenipho	low loaded system, performs biological N and P removal
BDN	Biodenitro	low loaded system, performs biological N removal
HLAS	high loaded activated sludge	high loaded system
LLAS	low loaded activated sludge	performs biological N and chemical P removal
LLAS_PS	LLAS with primary settler	performs biological N and chemical P removal
OD_bioP	oxidation ditch with bio-P removal	low loaded system, performs biological N and P removal
OD_simP	oxidation ditch with simultaneous P precipitation	low loaded system, performs biological N and chemical P removal
UCT	modified University of Cape Town	low loaded system, performs biological N and P removal

The flow to be treated biologically passes through a mixed tank (block “buffer”) that simulates the hydraulic retention time (HRT) of the preliminary treatment units, assumed to be 30 minutes.

Then the flow reaches the activated sludge process (in Figure 66 it is indicated by the block “PROCESS” but in general it is a combination of several blocks, see Appendix A) followed by a secondary settling tank (SST), constituted by a clarifier (“SST”) and by an activated sludge tank “SST\_react” which takes into account the volume of thickened sludge in the settler in which reactions take place in anoxic conditions, assumed to be 1/3 of the settler volume.

The underflow of the storm tank is controlled by “c\_sst” proportionally to the flow entering the biological treatment line (measured by “s\_flow”) with maximum and minimum flow values, additionally controlled by “c\_Q\_min” which prevents the underflow to be zero to avoid numerical problems.

Part of the underflow of the settler is wasted according to the action of the controller “c\_mlss”, which keeps a constant mixed liquor suspended solids (MLSS) concentration in the activated sludge tanks. This controller simulates an operator that, on the basis of MLSS measurements made every  $n$  days (where  $n$  is an integer), decides how many hours per day the waste sludge pump has to be switched on. The value of  $n$  is 3 days for 3,000PE, 2 days for 30,000PE and 1 day for 300,000PE. Concerning the MLSS concentration in the activated sludge tanks, it was set for configurations with primary settler to 3g/l in summer and 4g/l otherwise and for configurations without primary settler it was set to 3.5g/l in summer and 4.5g/l otherwise. For this purpose, summer has been defined as the period with mixed liquor temperature above 16°C.

The overflow of the settler is the effluent of the biological treatment line and is combined with the effluent of the storm tank before being converted from fluxes to concentrations (block “FC\_out”) and leaving the treatment plant.

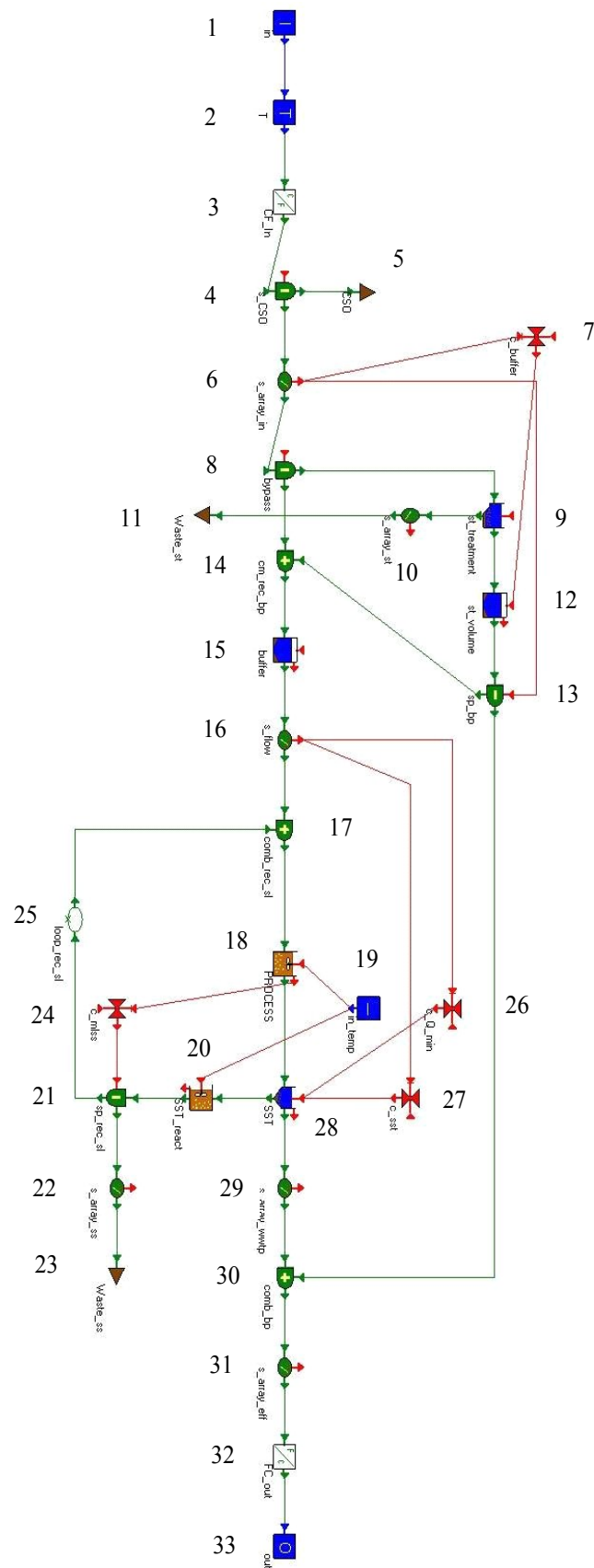

Figure 66: General plant layout in WEST; for node numbers explanation see Table 18.

Table 18: Legend for nodes of Figure 66.

Number	Name	Description
1	in	Influent data input in terms of COD, TN, etc. concentrations.
2	T	Data transformer (influent fractionator) from COD, TN, etc. to ASM2d state variables.
3	CF_In	Data transformer from concentrations to fluxes.
4	s_CSO	Splitter for CSO structure.
5	CSO	“Dump” output for CSO spilling.
6	s_array_in	Array of sensors, in this case measuring flow.
7	c_buffer	Controller for buffer tank pump.
8	bypass	Splitter for by-pass of water line to storm tank.
9	st_treatment	Point settler (no volume) for the sedimentation in the storm tank.
10	s_array_st	Array of sensors, measuring flow and TSS flux from storm tank sedimentation.
11	Waste_st	“Dump” output for storm tank sediment.
12	st_volume	Variable volume buffer tank with pump to account for the volume of the storm tank.
13	sp_bp	Splitter to treatment line and WWTP effluent.
14	cm_rec_bp	Combiner of flow returning from storm tank to treatment line.
15	buffer	Fixed volume buffer tank to account for the HRT of pre-treatments.
16	s_flow	Flow sensor.
17	comb_rec_sl	Combiner of secondary sludge recirculation to treatment line.
18	PROCESS	Represents a generic process, combination of several tanks, controllers, recirculations, etc.
19	in_temp	Data input for air temperature.
20	SST_react	AS tank accounting for the anoxic part of the sludge blanket in the clarifier.
21	sp_rec_sl	Splitter for secondary sludge to wastage.
22	s_array_ss	Array of sensors, measuring flow and TSS flux to wasted secondary sludge.
23	Waste_ss	“Dump” output for wasted secondary sludge.
24	c_MLSS	Controller of waste sludge as a function of TSS measured in the process tanks.
25	loop_rec_sl	Loop breaker; required for numeric integration.
26	c_Q_min	Controller for minimum flows; required to avoid numeric problems.
27	c_sst	Controller for clarifier underflow as a function of measured treatment line inflow.
28	SST	Secondary clarifier.
29	s_array_wwtp	Array of sensors, measuring COD, TN, etc. in the treatment line effluent.
30	comb_bp	Combiner of treatment line effluent and storm tank effluent.
31	s_array_eff	Array of sensors, measuring COD, TN, etc. in the combined effluent.
32	FC_out	Data transformer from fluxes to concentrations.
33	out	Effluent data output in terms of COD, TN, etc. concentrations.

## Dimensioning

The process volumes for single stage processes were dimensioned according to the ATV guidelines (ATV, 2000). The other processes were dimensioned according to Vesilind (2003). The requirements for nitrification volumes, anaerobic retention time and hydraulic load to the secondary clarifier were followed. In particular for nitrification, the suggested solids retention time (SRT) for different plant sizes at the temperature of 10°C was calculated using the sludge production figures obtained from steady state simulations of the processes. Such simulations were performed with the plants implemented in WEST using a constant input created following the influent characterisation suggested in the ATV guidelines.

For the tourist areas, the storm tanks were dimensioned on the basis not of the average dry weather flow during the year, but of the highest dry weather flow lasting for at least one sludge age (see yearly profiles in Figure 62), which is hereby referred as hydraulic peak load. The biological treatment lines were dimensioned by multiplying such hydraulic peak loads by a temperature factor (included in the ATV guidelines) to take into account the nitrification capacity at the temperature at which the hydraulic peaks occur. The values of such peaks are shown in Table 19. Appendix D shows the volumes calculated for all combinations of plant layout, size and climate.

Table 19: Load factors for tourist areas.

	Hydraulic peak load	ATV temperature factor	Biological peak load
<b>3.000PE Alpine</b>	2.5	1.2	3
<b>3.000PE Mediterranean</b>	3	0.5	1.5
<b>3.000PE Oceanic</b>	2	0.5	1
<b>30.000PE Alpine</b>	2	1.2	2.4
<b>30.000PE Mediterranean</b>	2	0.5	1

### 9.2.2 WWTP UPGRADE

From the 10 WWTP configurations assessed for plant design, the low loaded activated sludge plant (LLAS) was chosen as the basic layout to study several upgrade scenarios since it is one of the most widespread configurations in Europe.

The upgrades were implemented for the 300,000PE plant size, because this large sized plant is more likely to show beneficial effects than the smaller ones. The upgrade scenarios were simulated for the Continental and Mediterranean climate types since they are assumed to be the two most divergent types, in order to show the wider range of different performance of upgrades. An increase of loads of 33% (from 300,000PE to 400,000PE) has been applied to the influent of the plant to justify the need of upgrades.

Compared to the 300,000PE LLAS plant dimensioned for design, some changes were made in order to obtain the basic configuration called U0 (“upgrade zero”, not upgraded). This was necessary because the potential benefits of the different upgrade scenarios would not be obvious if they were applied to the originally over-dimensioned plant that was already complying with the effluent standards.

The safety margins built in the ATV dimensioning guidelines were removed by reducing the

plant size to 60% of its original volume. With this reduced tank volume, the plant effluent was still complying with the standards set in the EU Urban wastewater Directive (UWWD) (CEC, 1991) with the influent for 300,000PE, but not complying with the influent for 400,000PE (+33%). This means that to have the plant designed with ATV guidelines not complying with the UWWD it was necessary to more than double the load ( $1.33/0.6 > 2$ ).

It is to be noted that the compliance was checked for yearly averages on UWWD limits only; some Member States (e.g. Germany) have applied in their regulations stricter limits and/or limits based on effluents concentrations measured in short periods (e.g. 2-h composite samples) which require an analysis on the exceedance frequencies and lengths of the given concentration thresholds. Such restrictions challenge the treatment performance of WWTPs.

### Process configurations

The list of possibilities for upgrading a WWTP is extensive and case dependent. The upgrades that were chosen for evaluation seemed to be the most applicable scenarios for LLAS. Four of the upgrades are pure real time control (RTC) upgrades and therefore only require the installation of sensors, cables and controllers. The other eight upgrades also require constructions and equipment like pumping, piping and building of volumes.

In the following text, the upgrade scenarios will be referred to as U1, U2, ..., U12. Table 20 provides an overview of the studied upgrade scenarios. A description of the twelve upgrades can be found in Appendix C, including illustrations of the process layouts in WEST (when necessary). The reference case without upgrade is called U0, for which it is assumed that DO control is already implemented.

In RTC options, controller tuning is extremely important because an ill-tuned controller can be the cause for disadvantageous results, while the same controller with well-tuned parameter values could allow savings in operational costs and/or improvements in effluent quality. Tuning of controllers was conceived as a two step iterative process:

1. once a particular control strategy has been chosen, tuning of the constants is carried out by trial and error until the performance of the controller satisfies the a priori defined targets;
2. the definition of the target can be modified according to an evaluation of the operational costs or overall effluent quality.

An example illustrates this: if the chosen strategy is to keep a certain nitrate concentration at a pre-set value of  $2\text{mgNO}_3\text{-N/l}$ , parameter values have to be adjusted until the controller succeeds in maintaining that nitrate concentration in the range between e.g.  $1.5$  and  $2.5\text{mgNO}_3\text{-N/l}$ . The second step consists of an evaluation of the controller's performance in terms of operational costs and effluent quality. This second evaluation level may reveal that the set-point of  $2\text{mgNO}_3\text{-N/l}$  would better be lowered to  $1\text{mgNO}_3\text{-N/l}$ .

In many cases, WWTP upgrades turn out to be a trade-off between investment costs and effluent quality, which makes it hard to decide the endpoint of the iteration. In this work, the end target has been defined as making the plant comply with the effluent standards if those were not met without any upgrades. In case the plant already complied with the standards, the aim was to reduce operating costs without exceeding the effluent quality limits.



Table 20: Overview of the upgrade scenarios.

Sort name	Description	Requires construction	Requires RTC
U0	Reference case with no upgrade		
U1	Increase of aerated tank volume by 33%	X	
U2	U1 + increase of final clarifier area by 33%	X	
U3	U1 + pre-anaerobic tank + C dosage to denitro + lower DO set-point	X	X
U4	Dosage of external carbon source	X	X
U5	DO control based on ammonia		X
U6	Internal recycle control based on nitrate		X
U7	U4 + U6	X	X
U8	Spare sludge storage	X	X
U9	Sludge wastage control		X
U10	Dynamic step feed	X	X
U11	Increase in anoxic volume, decrease in aerated volume		X
U12	Buffering ammonia peak loads with the storm tank	X	X

### 9.3 Conclusions

In this chapter, the set of alternative process configurations for WWTP design and upgrade was described. The dimensioning of the activated sludge tanks and of the settlers was done by following the ATV guidelines and taking into account the load characteristics of the plant influent according to the climate and catchment type.

Concerning the upgrades dimensioning, it is to be noted that to be able to have process volumes not able to comply with the UWWD (limits on yearly averages), it was necessary to more the double the loading of the plant dimensioned according to ATV guidelines. Stricter regulations setting other than yearly averages (e.g. exceedance of concentration thresholds) would change this, requiring larger volumes, closer to the ones from ATV guidelines.

The models of the configurations were implemented in WEST and the simulations were performed in Tornado, a recently developed simulation kernel which allows flexibility of use and fast simulation speed.



## MODELLING FOR IMMISSION-BASED EVALUATION

*Parts of this chapter have been published as:*

**Benedetti, L., Meirlaen, J., Sforzi, F., Facchi, A., Gandolfi, C. and Vanrolleghem, P. A. (2004).** *Dynamic integrated modelling: A case study on the river Lambro. In: Proceedings of the NOVATECH 2004, Lyon, France, 6-10 June 2004.*

**Benedetti, L., Meirlaen, J. and Vanrolleghem, P.A. (2004).** *Model connectors for integrated simulations of urban wastewater systems. In: Sewer Networks and Processes within Urban Water Systems. Bertrand-Krajewski, J.-L., Almeida, M., Matos, J. and Abdul-Talib, S. (eds), pp. 13-21, IWA Publishing, London, UK.*

*Vanrolleghem, P.A., Rosen, C., Zaher, U., Copp, J., Benedetti, L., Ayesa, E. and Jeppsson, U. (2005).* *Continuity-based interfacing of models for wastewater systems described by Petersen matrices. Water Science and Technology 52(1-2), 493-500.*

**Solvi, A.-M., Benedetti, L., Vandenberghe, V., Gillé, S., Schlosseler, P., Weidenhaupt, A. and Vanrolleghem, P.A. (2006).** *Implementation of an integrated model for optimised urban wastewater management in view of better river water quality: A case study. In: Proceedings of IWA World Water Congress 2006, Beijing, China, 10-14 September.*

In case also an immission-based evaluation of the alternative measures is required (see Figure 67), the models of the involved sub-systems (catchment, sewer network, WWTP, river stretch) must be implemented and integrated. Each component of the systems under analysis needs to be appropriately modelled, then the sub-models must be linked to be able to simulate the behaviour of the whole system. In this study, the components making up the studied system are the WWTP – composed of activated sludge tanks and settlers – and a river stretch. This chapter describes the river model used and the interfacing approach used to link it with the WWTP model introduced in Chapter 9.

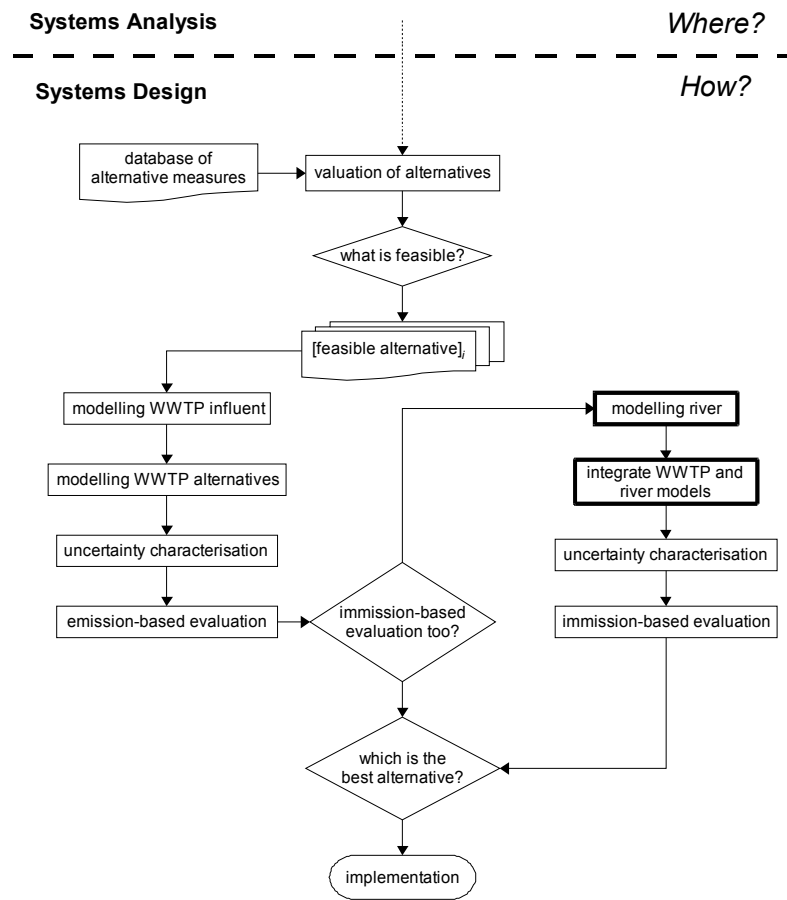

Figure 67: Integrated modelling for immission-based evaluation within Systems Design.

## 10.1 Tools

### 10.1.1 RIVER MODEL

A sub-model of the RWQM1 (Reichert *et al.*, 2001) has been implemented, based on the work of Solvi *et al.* (2006) to model the river Sure in Luxembourg. This sub-model does not include processes and state variables for which there were no data available or were of no relevance for the river Sure. This is the case for all chemical pH-dependent reactions and for the state variable “consumers” (and connected processes). An RWQM1 sub-model similar to the one adopted in this study had been successfully tested on a South African basin (Deksissa *et al.*, 2001) and on an Italian basin (Benedetti *et al.*, 2004a).

Hydrolysis, bacterial and algal growth are functions of water temperature. A heat balance model was implemented in the river model to consider the effect of atmospheric changes on water temperature. Based on the model (see Figure 68) of Talati and Stenstrom (1990), the model includes the effects of solar radiation, atmospheric radiation, surface evaporation and surface convection as a function of water surface and time series of daily incoming water temperature, radiation intensity, air temperature, wind speed, relative humidity. An addition was made to include the contribution of

base flow coming from groundwater, characterised by quantity and temperature of incoming groundwater. In the actual implementation of the model,  $H_p$ ,  $H_b$  and  $H_{tw}$  were neglected since they are of minor relative importance (Gillot and Vanrolleghem, 2003).

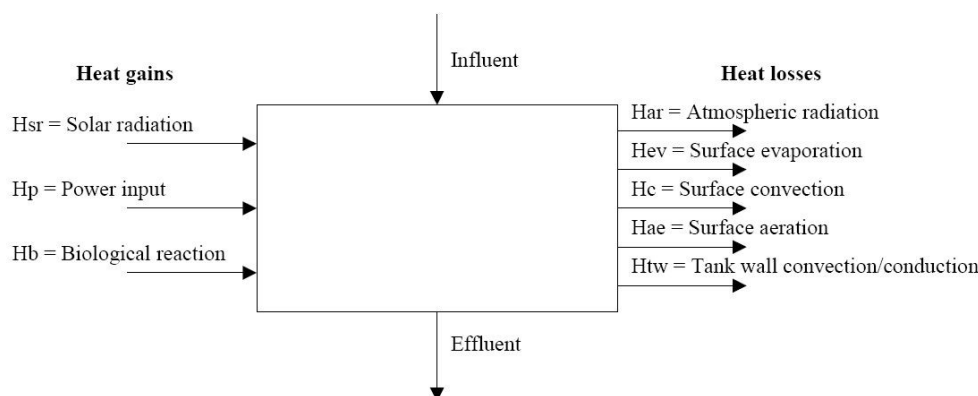

Figure 68: Overview of the heat exchanges over the river.

Note that a rainfall/runoff and sewer model was made available too in the adopted software platform (Solvi *et al.*, 2005), but it was not used for this illustration of the methodology.

## 10.1.2 MODEL INTERFACES

### ASM to RWQM1 interfacing

A model interface to connect the activated sludge model to the river model had to be built to evaluate the effect of WWTP effluent to the river water quality. The principles of its functioning are illustrated by an example of ASM1-RWQM1 connection.

The interface is a list of algebraic equations expressing concentration inputs in the river in terms of concentration outputs from the sewer or WWTP.

RWQM1 uses COD as a measure for organic pollution, which is in contrast with the more traditional river water quality models. This makes integration with the also COD-based ASM models easier. Moreover, RWQM1 has closed mass balances for COD and closed elemental balances for C, N, P, O and H. Since these are important properties, the goal was to keep these in the new connector.

Due to the modelling approach used in RWQM1, some state variables can be very easily transformed from the activated sludge to the river conditions. Slowly and readily biodegradable substances will probably remain biodegradable when entering the river. One could also suppose that the active biomass coming from the sewer or activated sludge system would remain active biomass in the river. However, this is probably not completely true since the environmental conditions in the sewer or treatment plant and the river are usually very different in terms of temperature, food, light intensity, etc. (as a consequence these three variables may also vary with the period of the year), probably causing inactivity of at least part of the biomass. In the connector, biomass is split into a part that remains active and a part that is transformed into inert and slowly biodegradable organic matter. This active fraction can be assumed to be larger for biomass from sewage than from activated sludge.

Autotrophic biomass is modelled as first step and second step nitrifiers in RWQM1, but only as one group of organisms in the ASM1. In the connector the incoming autotrophic biomass is split into two active groups, first and second step nitrifiers (with respective surviving fractions  $f_{N1}$  and  $f_{N2}$ ), while the remaining (dead) part is split into slowly biodegradable and inert particulate organic matter. Parameters for the fractions are to be found by calibration, since so far no values are available in literature, only the relationship  $f_{N1} = 3 \cdot f_{N2}$  (Focht and Verstraete, 1977) can be useful as a first approximation. Dead biomass is split in two particulate fractions, one biodegradable and one inert, calculated by means of the parameter  $f_i$ , that is likely to be similar to the parameter  $f_p$  present in ASM1, since the concept is exactly the same, even if it has to be considered that environmental conditions are different.

The way in which particulate matter and soluble components is transformed when going from the treatment plant to the river is shown in Figure 69.

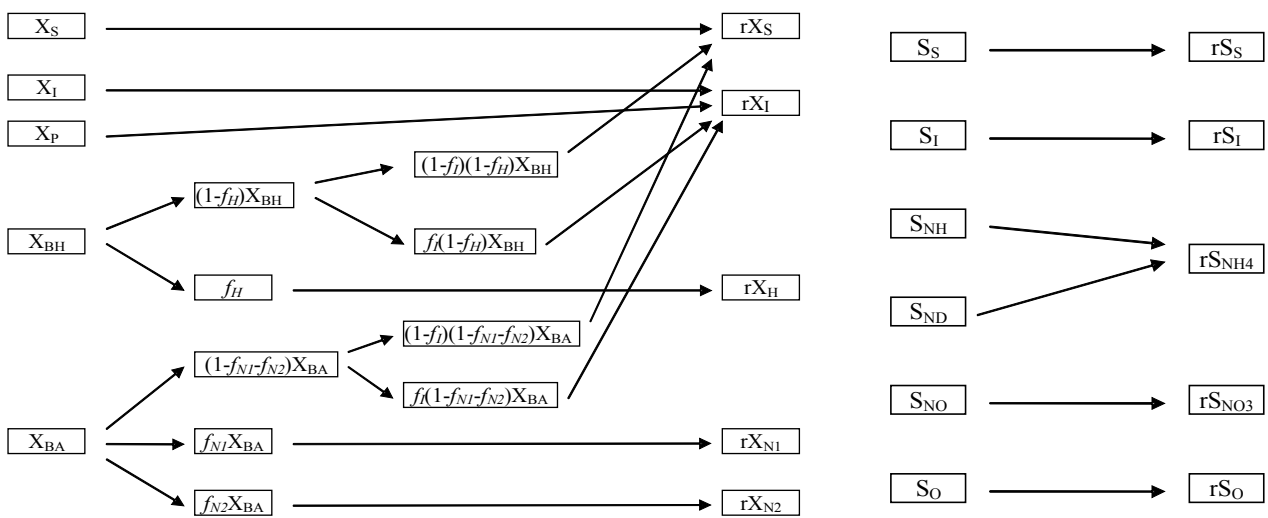

Figure 69: Fate of particulate biomass (left) and of soluble components (right) from state variables of ASM1 to RWQM1.

To calculate the output concentrations of the three species of carbonates ( $\text{CO}_2$ ,  $\text{HCO}_3^-$  and  $\text{CO}_3^{2-}$ ) in the river model, the carbonate equilibrium equations have been implemented. They are a function of incoming alkalinity (state variable in ASM1) and pH, which has been considered as a parameter of the connector. pH is assumed to be fixed since no large variations are expected in a WWTP effluent and because the modelled river has large buffering capacity.

Soluble organic nitrogen ( $S_{ND}$  in ASM1) is added to  $\text{NH}_4$  in the output, since the ammonification process is usually fast and no similar state is present in the river model.

Variables that are used in the RWQM1, but not in the ASM1, like nitrite, particulate phosphate or algae, are set by fixed connector parameters, which need to be estimated for the system under study.

After finishing all these logical transformations that close the COD balance, elemental balances still need to be closed. This is done using compensation terms, which are used to compensate for a lack or surplus of elements. To this end, the elemental flux calculated in ASM1 state variables should be compared to the elemental flux calculated in RWQM1 state variables. For each element (e.g. N), the difference between these two fluxes (either negative or positive) is the compensation

term and needs to be added to the state variable in RWQM1 (e.g.  $rS_{NH_4}$ ) chosen to serve as a balance term for the element. In an ideal set of models and connectors, compensation terms should always be zero.

A balance term serves as a sink or source of elements in the organic compounds, e.g. if more nitrogen is present in the organic matter entering the river than is coming from the treatment plant, then the amount of ammonia going into the river is artificially decreased in order to close the nitrogen balance over the connector. The following equation illustrates the use of a compensation term for nitrogen, which in the connector is added to the outgoing  $rS_{NH}$  balance term.

$$N\_comp = \begin{bmatrix} i_{N\_SS} \cdot S_S + i_{N\_SI} \cdot S_I + i_{N\_XS} \cdot X_S + i_{N\_XI} \cdot X_I \\ + i_{N\_XBH} \cdot X_{BH} + i_{N\_XBA} \cdot X_{BA} + i_{N\_XP} \cdot X_P \\ - i_{N\_rSS} \cdot rS_S - i_{N\_rSI} \cdot rS_I - i_{N\_rXH} \cdot rX_H - i_{N\_rXN1} \cdot rX_{N1} \\ - i_{N\_rXN2} \cdot rX_{N2} - i_{N\_rXS} \cdot rX_S - i_{N\_rXI} \cdot rX_I \end{bmatrix}$$

or

$$N\_comp = \sum_J^{ASM1} i_{N\_J} \cdot J - \sum_J^{RWQM1} i_{N\_J} \cdot J$$

in which  $i_{N\_J}$  is the nitrogen content of component J

$S_i, X_i$  are components of the ASM1 model (gCOD/m<sup>3</sup>)

$rS_i, rX_i$  are components of RWQM1 (gCOD/m<sup>3</sup>)

The balance terms chosen in the river model are carbonates ( $rS_{CO_2}$ ) for carbon,  $NH_4^+$  ( $rS_{NH_4}$ ) for nitrogen,  $HPO_4^{2-}$  ( $rS_{HPO_4}$ ) for phosphorus, DO ( $rS_O$ ) for oxygen and  $H^+$  ( $rS_H$ ) for hydrogen. To calculate the flux of the five elements one needs to fix the composition of the different model components in both ASM1 and RWQM1. For ASM1 (see Table 21), the nitrogen and phosphorus content were taken according to Henze *et al.* (2000) (N from ASM1 and P from ASM2), while carbon, oxygen and hydrogen content were taken according to Reichert *et al.* (2001). For RWQM1 (see Table 22), the components' compositions came from Reichert *et al.* (2001); note that in Table 22 the values are in grams of element per gram of organic mass (OM) and are then transformed into grams of element per gram of COD by using the conversion factors in Table 23 according to Reichert *et al.* (2001).

Table 21: Elemental composition of ASM1 state variables.

	$S_S$	$S_I$	$X_{BH}$	$X_{BA}$	$X_S$	$X_I$	$X_P$	Unit
$i_C$	0.31	0.31	0.33	0.33	0.31	0.31	0.31	gC/gCOD
$i_H$	0.06	0.06	0.05	0.05	0.06	0.06	0.06	gH/gCOD
$i_O$	0.29	0.29	0.16	0.16	0.29	0.29	0.29	gO/gCOD
$i_N$	0.04	0.04	0.08	0.08	0.04	0.03	0.03	gN/gCOD
$i_P$	0.01	0.01	0.02	0.02	0.01	0.01	0.01	gP/gCOD

Table 22: Elemental composition of RWQMI state variables.

	$rS_S$	$rS_I$	$rX_H$	$rX_{N1}$	$rX_{N2}$	$rX_{ALG}$	$rX_{CON}$	$rX_S$	$rX_I$	Unit
$\alpha_C$	0.43	0.43	0.52	0.52	0.52	0.355	0.355	0.43	0.43	gC/gOM
$\alpha_H$	0.09	0.09	0.08	0.08	0.08	0.07	0.07	0.09	0.09	gH/gOM
$\alpha_O$	0.40	0.40	0.25	0.25	0.25	0.50	0.50	0.40	0.40	gO/gOM
$\alpha_N$	0.06	0.06	0.12	0.12	0.12	0.06	0.06	0.06	0.06	gN/gOM
$\alpha_P$	0.02	0.02	0.03	0.03	0.03	0.015	0.015	0.02	0.02	gP/gOM

Table 23: Organic mass to COD conversion factors for RWQMI state variables.

$rS_S$	$rS_I$	$rX_H$	$rX_{N1}$	$rX_{N2}$	$rX_{ALG}$	$rX_{CON}$	$rX_S$	$rX_I$	Unit
1.390	1.390	1.610	1.610	1.610	0.923	0.923	1.390	1.390	gCOD/gOM

A number of simulations have been performed to test the influence of several factors on the connector performance. To represent the behaviour of a combined sewer overflow discharging directly in a river reach, the dry weather influent file for the ‘benchmark’ (Copp *et al.*, 2002) has been used as input to the connector between the sewer system and a river stretch. The values of the adjustable parameters in the connector are specified in Table 24.

Table 24: Values for adjustable connector parameters.

Parameter	Description	Value
$f_H$	fraction of active heterotrophs	0.5
$f_{N1}$	fraction of active first step nitrifiers	0.15
$f_{N2}$	fraction of active second step nitrifiers	0.45
$f_I$	fraction of biomass that becomes inert particulate	0.08
pH	pH	7

In Figure 70 the magnitude and evolution of the compensation terms are presented. It can be noticed that only carbon has a positive mass balance, while all other elements have a rather negative balance. This is due to the strong influence of the elemental composition of state variables on the elemental balances. A consequence is that, as evident in Figure 71, the concentration of some river state variables coming out of the connector is calculated to be negative (in this case  $S_{H+}$ ), which should in general be avoided.

As an example, the influence of the parameters indicating oxygen and nitrogen contents in inert particulate matter ( $i_{O_{XI}}$  and  $i_{N_{XI}}$ ) on oxygen and nitrogen balances has been simulated. Results are shown in Figure 72. It is to be noticed that assuming the reference value of  $i_{N_{XI}}$  in ASM2 (0.03gN/gCOD) or in ASM2d (0.02gN/gCOD) leads to a difference in the nitrogen balance of almost 0.5gN/m<sup>3</sup>. It is evident from the oxygen balance that small changes in this type of



parameters have effects of paramount importance on the elemental mass balances (Takacs and Vanrolleghem, 2006). A consequence is that the fractionation in model state variables of measurements of COD, BOD, TN, TP and similar data, coming from routine monitoring or special laboratory analyses, may also be considered from the point of view of elemental mass balances. This is especially true in the case of integrated modelling with conversion of state variables from one model to another.

The most influencing parameter in the connector is probably  $f_H$  (fraction of active heterotrophs), the effect of which on elemental balances and connector relevant outputs is shown in Figure 73 and Figure 74 respectively. Since the oxygen content in the benchmark influent is close to zero,  $f_H$  is the only connector parameter responsible for the variations of oxygen in the connector output. Some influence on elemental balances is also exerted by  $f_{N1}$  and  $f_{N2}$  (fractions of active autotrophs), but negligible compared to  $f_H$  since the concentration of autotrophs in sewage is usually very small.

Applications of this connector can be found in Meirlaen *et al.* (2001), Benedetti *et al.* (2004a) and Benedetti *et al.* (2004b).

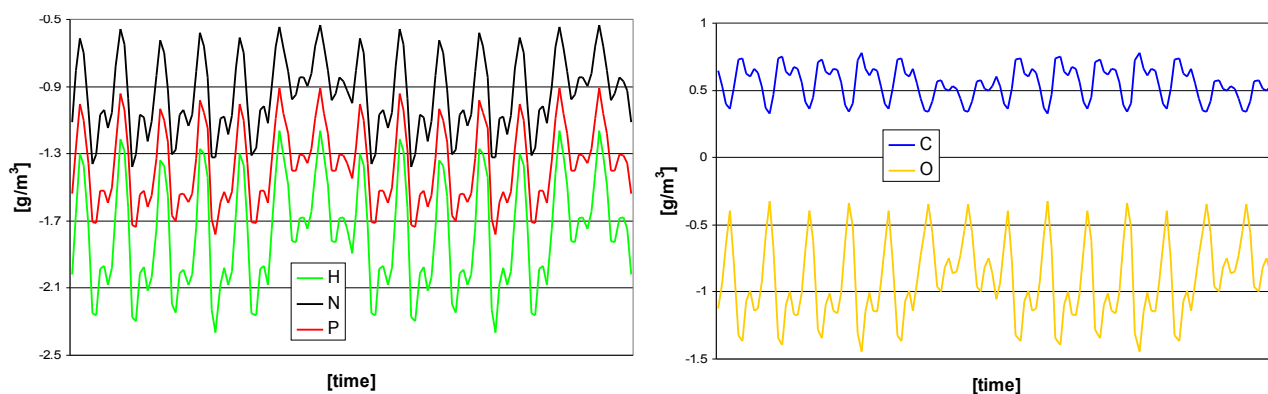

Figure 70: Dynamic profiles of compensation terms.

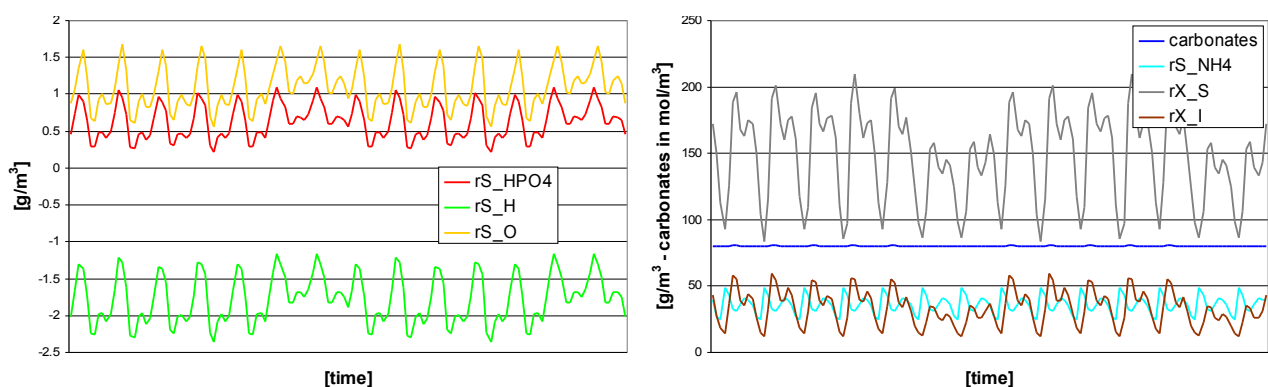

Figure 71: Dynamic profiles of relevant connector outputs.

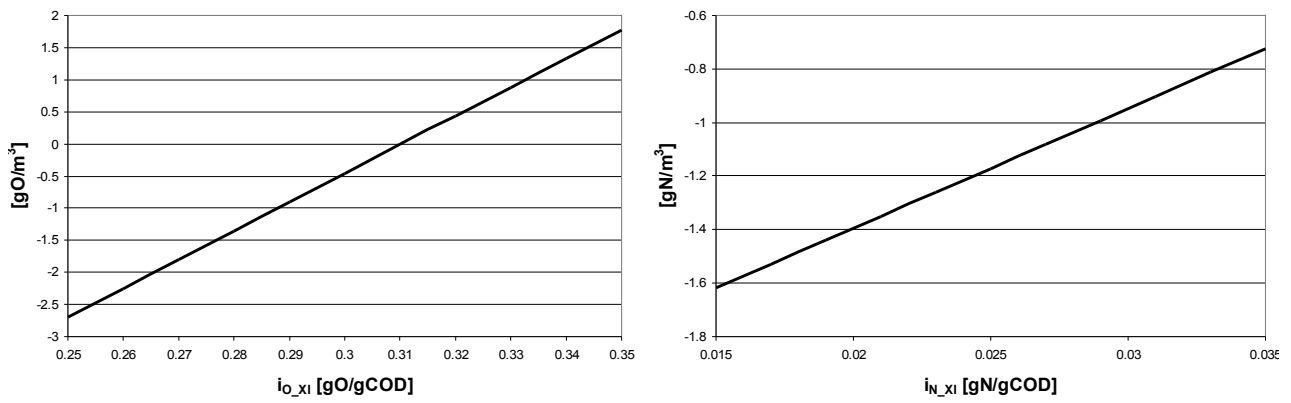

Figure 72: Influence of  $i_{O,XI}$  and  $i_{N,XI}$  on O (left) and N (right) balances.

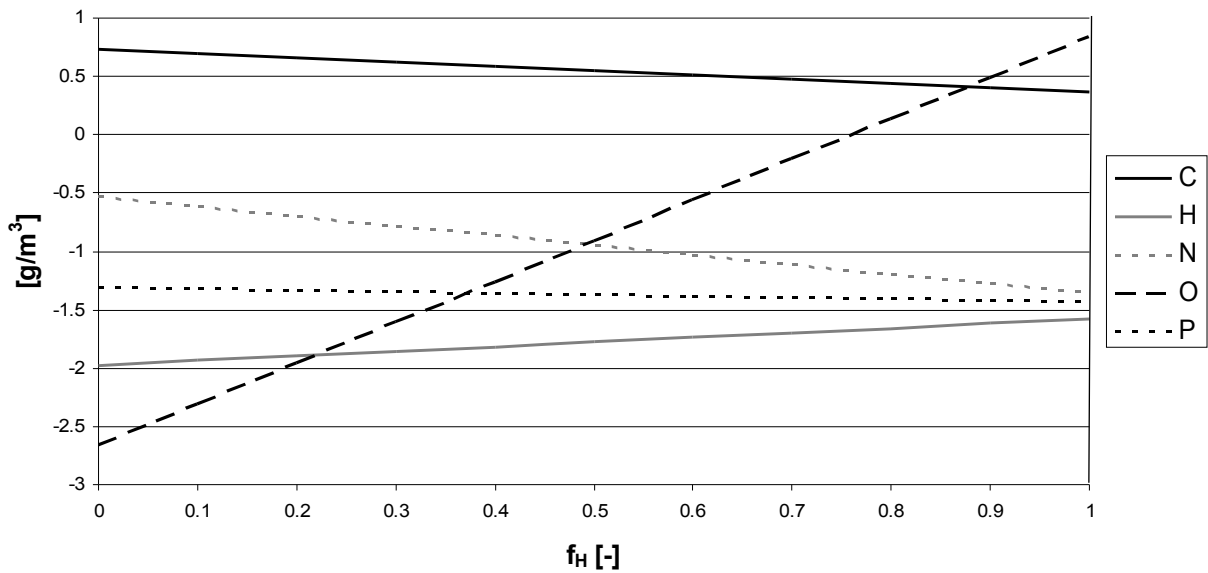

Figure 73: Influence of  $f_H$  on the elemental mass balances.

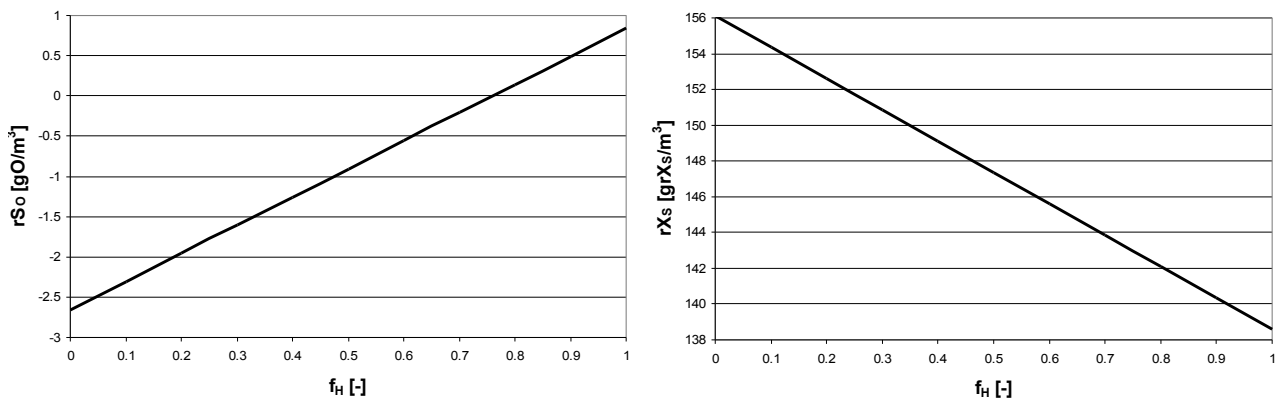

Figure 74: Influence of  $f_H$  on the most sensitive connector outputs,  $rS_O$  (left) and  $rX_S$  (right).

## The continuity-based interfacing method (CBIM)

By applying the CBIM – compared to the method described above, from which CBIM was developed – it is possible to have a much more formalised frame and it has the advantage of minimising compensation terms.

Through this approach it is possible to build an interface between the two models, maintaining the continuity of C, H, N, P, O, charge and COD, while the two models remain unaltered.

The followed methodology consists of the following steps:

1. Formulation of elemental mass fractions and charge density.
2. Set-up of the composition matrices.
3. Definition of the transformation matrix.
4. Implementation of the transformation equations.

### *Formulation of elemental mass fractions and charge density*

The main hypothesis in this phase is that the mass of each component is made up of constant fractions of the elements C, N, O, H and P. The elemental mass fractions  $\alpha^C, \alpha^H, \alpha^O, \alpha^P, \alpha^N$  are in grams of element per gram of component; as a result, the sum of all fractions must be unity. Then also  $\alpha^{COD}$  and  $\alpha^{Ch}$  (*Ch* stands for “charge”) can be calculated.

The COD equivalent of a component is defined as the grams of oxygen that are consumed during oxidation of a mass unit of the component to  $\text{NH}_4^+$ ,  $\text{CO}_2$ ,  $\text{H}_2\text{O}$ ,  $\text{H}^+$  and  $\text{PO}_4^{3-}$ . The COD equivalent of a component is related to the mass fractions of elements and charge through the relationship (Reichert *et al.*, 2001):

$$\alpha^{COD} = 32 \cdot \frac{\alpha^C}{12} + 8\alpha^H - 16\frac{\alpha^O}{16} - 24\frac{\alpha^N}{14} + 40\frac{\alpha^P}{31} - 8\alpha^{Ch}$$

For the components for which the elemental composition is known, the calculation of the mass fractions and of the charge density is straightforward, since the molecular weight is known. Hence also the calculation of the COD content is possible by using the given formula.

For the components for which the elemental composition is not known, it is necessary to make some assumptions and to use data provided by literature (e.g. by Reichert *et al.*, 2001).

### *Set- up of the composition matrices*

Once the composition of each state variable in terms of elements, charge and COD content is known, the set up of the matrix is straightforward. An element of the composition matrix –  $i_k^E$  where  $k$  is the component and  $E$  is the “element” (N, O, P, H, C, charge or COD) – is the elemental fraction of a component per mass unit of the component. The relationship between  $i_k^E$  and  $\alpha_k^E$  is:

$$i_k^E = \alpha_k^E \cdot M_k$$

where  $M_k$  is the mass of the component  $k$  expressed in gram per mass unit. Thus, as the represent the grams of element  $E$  per gram of component  $k$ , the  $i_k^E$  represent the grams of element  $E$  per mass unit.

### Definition of the transformation matrix

The main concept behind the transformation matrix is that the components of the original model are transformed completely into the variables of the destination model. To ensure this, a number of transformations have to be specified. The definition of these equations depends on the knowledge available on the processes. Usually the number of transformations to be defined is equal to the number of state variables of the origin model. Each transformation converts a number of components of the origin model to a number of components of the destination model.

Every transformation  $j$  for component  $k$  is characterized by its stoichiometry  $v_{j,k}$ . While stoichiometry coefficients of the origin components are set to an arbitrary value (with negative sign in order to maintain the right direction of the transformation) the of the destination state variables are set as each transformation maintains the COD content. Each transformation is also characterized by its rate  $\rho_j$  which, together with the stoichiometry coefficient, specifies the amount of the component  $k$  transformed per unit of time, equal to  $v_{j,k} \cdot \rho_j$ .

For each of the  $n$  transformation equations elemental continuity (N, O, P, C, H, charge and COD) must be guaranteed. To close all balances, the compensation terms must be defined, which are components which act as source or sink for a certain element.

The H balance is automatically closed since the balances are linearly independent. The COD balance is closed by the transformation equations. The stoichiometric coefficients can be calculated at once, by solving the matrix equation (where  $m$  is the number of components):

$$\begin{bmatrix} i_{HPO4-}^P & i_{H+}^P & i_{H2O}^P & i_{NH4}^P & i_{HCO3-}^P \\ i_{HPO4-}^{Ch} & i_{H+}^{Ch} & i_{H2O}^{Ch} & i_{NH4}^{Ch} & i_{HCO3-}^{Ch} \\ i_{HPO4-}^O & i_{H+}^O & i_{H2O}^O & i_{NH4}^O & i_{HCO3-}^O \\ i_{HPO4-}^N & i_{H+}^N & i_{H2O}^N & i_{NH4}^N & i_{HCO3-}^N \\ i_{HPO4-}^C & i_{H+}^C & i_{H2O}^C & i_{NH4}^C & i_{HCO3-}^C \end{bmatrix} \cdot \begin{bmatrix} v_{j,HPO4} \\ v_{j,H+} \\ v_{j,H2O} \\ v_{j,NH4} \\ v_{j,HCO3-} \end{bmatrix} = \begin{bmatrix} - \sum_m i_m^P \cdot v_{j,m} \\ - \sum_m i_m^{Ch} \cdot v_{j,m} \\ - \sum_m i_m^O \cdot v_{j,m} \\ - \sum_m i_m^N \cdot v_{j,m} \\ - \sum_m i_m^C \cdot v_{j,m} \end{bmatrix}$$

Hence, the unknown array of the  $v_{j,m}$  of the compensation components can be calculated.

For each transformation  $j$  the elemental continuity must be guaranteed, which is easily checked by the equation (where  $k$  are the components and  $E$  the elements):

$$\sum_k v_{j,k} \cdot i_{k,E} = 0$$

## Implementation of the transformation equations

The set of interface unknowns consists of the stoichiometric coefficients  $v_{j,k}$  and the transformation rates. Together they enable the calculation of the outflux from the destination model. In order to solve the unknowns it is necessary to set up a system of two equations taking into account the fluxes in and out from the interface.

$$\begin{cases} \Phi_k^{in} = -\sum_{j=1}^N v_{jk} \cdot \rho_j & k = 1, \dots, P \\ \Phi_k^{out} = \sum_{j=1}^N v_{jk} \cdot \rho_j & k = P+1, \dots, P+Q \end{cases}$$

where  $\Phi_k^{in}$  is the known positive influx of a component of the origin model,  $\Phi_k^{out}$  is the unknown outflux of a component of the destination model,  $P$  is the number of origin state variables and  $Q$  is the number of destination state variables.

It is important to check that all transformation rates are positive, in order to assure that the transformations are in the right direction (origin model to destination model). In case this is not verified, the transformation equations should be modified.

## 10.2 Scenarios

### 10.2.1 THE ASM2D TO RWQM1 INTERFACE

The model interface realised for this work – connecting ASM2d to the simplified RWQM1 – was developed using the CBIM approach, following the principles explained above regarding the connection of a river and an activated sludge model.

In this study the following assumptions have been made (see Table 25 and Table 26 for the values):

- in ASM2d,  $X_{PAO}$  and  $X_{AUT}$  have the same composition as  $X_H$ ;
- in RWQM1,  $X_P$  has the same composition as  $S_{HPO_4}$ ;
- in RWQM1, only  $S_{HPO_4}$  was considered as inorganic dissolved phosphorous.

To be able to use the appropriate compensation terms, two more state variables were added to both origin and destination models:  $S_{H^+}$  and  $S_{H_2O}$ . The following is the choice made for this study:

- The N balance is closed with  $NH_4^+$
- The O balance is closed with  $H_2O$

- The P balance is closed with  $\text{HPO}_4^{2-}$
- The C balance is closed with  $\text{HCO}_3^-$
- The charge balance is closed with  $\text{H}^+$

Since the state variables in the two models are not the same, or do not have the same meaning or the same composition, some assumptions have to be taken. Some state variables have the same meaning and elemental composition and for these the transformation is straightforward (e.g.  $S_1$  and  $S_{\text{NO}_3}$ ). Other state variables are not passed on, while other needs to be split or merged, when setting up the interface. Below the main assumptions made defining the transformation equations can be found (see Table 24 for parameter values):

- $X_{\text{PAO}}$ , the phosphate accumulating organisms, are assumed to live only in the activated sludge tank environment and since environmental conditions are very different in the river, they are no longer active in the second model. They were split into two fractions by means of the parameter  $f_S$ :  $X_{\text{I}}$ , inert particulate organic material and  $X_{\text{S}}$ , slowly biodegradable substrate;
- $X_{\text{PHA}}$ , a cell internal storage product of PAOs; since PAOs are no longer active in the river, it was assumed that  $X_{\text{PHA}}$  is completely transformed in  $S_{\text{S}}$ ;
- $X_{\text{PP}}$ , polyphosphate, is a cell internal inorganic storage product of PAOs; since it occurs only associated to PAOs, it was assumed that  $X_{\text{PP}}$  is completely transformed in phosphate,  $S_{\text{HPO}_4}$ ;
- $X_{\text{H}}$ , heterotrophic organisms, are affected by the conditions in the river which are different then in the activated sludge tank, so  $X_{\text{H}}$  was split into two fractions by means of the parameter  $f_H$ : one active and one inactive. The inactive part is then divided by means of the parameter  $f_S$  into  $X_{\text{S}}$  and  $X_{\text{I}}$ ;
- $X_{\text{AUT}}$ , nitrifying organisms, have the same fate as  $X_{\text{H}}$ , thus they are split into an active part (divided in first and second step nitrifiers  $X_{\text{N1}}$  and  $X_{\text{N2}}$  by means of the parameters  $f_{\text{N1}}$  and  $f_{\text{N2}}$ ) and into an inactive part ( $X_{\text{S}}$  and  $X_{\text{I}}$ );
- for  $S_{\text{N}_2}$ ,  $X_{\text{MeOH}}$  and  $X_{\text{MeP}}$ , it is assumed that they are not passed on when entering the interface: nitrogen gas is not consumed in any reaction and is considered free to leave the system at the water-atmosphere interface, while for  $X_{\text{MeOH}}$  and  $X_{\text{MeP}}$  no transformations occur in the river system.

Table 27 and Table 28 show the transformation matrix for the connector.

Table 25: Composition matrix of ASM2d.

	1	2	3	4	5	6	7	8	9	10	11	12	13	14	15	16	17	18	19	20
	S <sub>A</sub>	S <sub>ALK</sub>	S <sub>F</sub>	S <sub>I</sub>	S <sub>N2</sub>	S <sub>NH4</sub>	S <sub>NO3</sub>	S <sub>O2</sub>	S <sub>PO4</sub>	X <sub>AUT</sub>	X <sub>H</sub>	X <sub>I</sub>	X <sub>MOH</sub>	X <sub>MeP</sub>	X <sub>PAO</sub>	X <sub>PHA</sub>	X <sub>PP</sub>	X <sub>S</sub>	S <sub>H+</sub>	S <sub>H2O</sub>
	(gCOD m <sup>-3</sup> )	(mol m <sup>-3</sup> )	(gCOD m <sup>-3</sup> )	(gCOD m <sup>-3</sup> )	(gN m <sup>-3</sup> )	(gN m <sup>-3</sup> )	(gN m <sup>-3</sup> )	(-gCOD m <sup>-3</sup> )	(gP m <sup>-3</sup> )	(gCOD m <sup>-3</sup> )	(gCOD m <sup>-3</sup> )	(gCOD m <sup>-3</sup> )	(gFe(OH) <sub>3</sub> m <sup>-3</sup> )	(gFePO <sub>4</sub> m <sup>-3</sup> )	(gCOD m <sup>-3</sup> )	(gCOD m <sup>-3</sup> )	(gP m <sup>-3</sup> )	(gCOD m <sup>-3</sup> )	(gH m <sup>-3</sup> )	(gH m <sup>-3</sup> )
Balance (g/gMatter)																				
α C	0.407	0.197	0.570	0.610	0.000	0.000	0.000	0.000	0.000	0.520	0.520	0.610	0.000	0.000	0.520	0.558	0.000	0.570	0.000	0.000
α H	0.051	0.016	0.080	0.070	0.000	0.222	0.000	0.000	0.010	0.080	0.080	0.070	0.059	0.000	0.080	0.070	0.000	0.080	1.000	0.111
α O	0.542	0.787	0.280	0.280	0.000	0.000	0.774	1.000	0.667	0.250	0.280	0.941	0.674	0.250	0.372	0.608	0.280	0.280	0.000	0.889
α N	0.000	0.000	0.060	0.030	1.000	0.778	0.226	0.000	0.000	0.120	0.120	0.030	0.000	0.000	0.120	0.000	0.000	0.060	0.000	0.000
α P	0.000	0.000	0.010	0.010	0.000	0.000	0.000	0.000	0.323	0.030	0.030	0.010	0.000	0.326	0.030	0.000	0.392	0.010	0.000	0.000

Table 26: Composition matrix of simplified RWQM1.

	1	2	3	4	5	6	7	8	9	10	11	12	13	14	15	16	17
	S <sub>s</sub>	S <sub>i</sub>	S <sub>NH4</sub>	S <sub>NO2</sub>	S <sub>NO3</sub>	S <sub>HPO4</sub>	S <sub>O2</sub>	S <sub>H</sub>	S <sub>GH</sub>	X <sub>H</sub>	X <sub>N1</sub>	X <sub>N2</sub>	X <sub>ALG</sub>	X <sub>S</sub>	X <sub>I</sub>	X <sub>P</sub>	S <sub>H2O</sub>
	(gCOD m <sup>-3</sup> )	(gCOD m <sup>-3</sup> )	(gN m <sup>-3</sup> )	(gN m <sup>-3</sup> )	(gN m <sup>-3</sup> )	(gP m <sup>-3</sup> )	(-gCOD m <sup>-3</sup> )	(gH m <sup>-3</sup> )	(gH m <sup>-3</sup> )	(gCOD m <sup>-3</sup> )	(gCOD m <sup>-3</sup> )	(gCOD m <sup>-3</sup> )	(gCOD m <sup>-3</sup> )	(gCOD m <sup>-3</sup> )	(gCOD m <sup>-3</sup> )	(gP m <sup>-3</sup> )	(gH m <sup>-3</sup> )
Balance (g/gMatter)																	
α C	0.570	0.610	0.000	0.000	0.000	0.000	0.000	0.000	0.000	0.520	0.520	0.520	0.360	0.570	0.610	0.000	0.000
α H	0.080	0.070	0.222	0.000	0.000	0.010	0.000	1.000	0.059	0.080	0.080	0.080	0.070	0.080	0.070	0.010	0.111
α O	0.280	0.280	0.000	0.696	0.774	0.667	1.000	0.000	0.941	0.250	0.250	0.250	0.500	0.280	0.280	0.667	0.889
α N	0.060	0.030	0.778	0.304	0.226	0.000	0.000	0.000	0.000	0.120	0.120	0.120	0.010	0.060	0.030	0.000	0.000
α P	0.010	0.010	0.000	0.000	0.000	0.323	0.000	0.000	0.000	0.030	0.030	0.030	0.060	0.010	0.010	0.323	0.000







## 10.2.2 INTEGRATING WWTP AND RIVER

In order to give an example of immission-based evaluation of upgrade options, a model of a hypothetical river was linked to the LLAS model for 300,000PE (see Figure 78).

The river model is constituted by 5 tanks in series each representing a river stretch 1000m long and 30m wide, for a total length of 5000m. The first tank receives an input from the upstream river which is adapted from real river measurement data (Solvi *et al.*, 2006) by rescaling flow to have a ratio (dilution factor) of 5 between yearly river flow and yearly WWTP flow and another input from the effluent of the LLAS treatment plant model, which includes the biological treatment effluent, the storm tank effluent and the CSO effluent. The river stretch investigated by Solvi *et al.* (2006) is located in North-West Luxembourg and is characterised by gentle slopes meandering and by the presence principally of agriculture and industries (especially mines) along its banks.

Figure 75 to Figure 77 show time series of the river upstream influent. Such influent time series were generated by using reliable flow measurements, but only sparse data concerning pollutant concentrations (monthly grab samples). The flow peak in April (Figure 75) is due to the snow melt in the catchment. In Figure 76, the long time-scale oscillations are due to the matching with the available data, while the short time-scale oscillations are generated by the presence of algae in the river (increasing in the warm period) which amplifies the daily cycles.

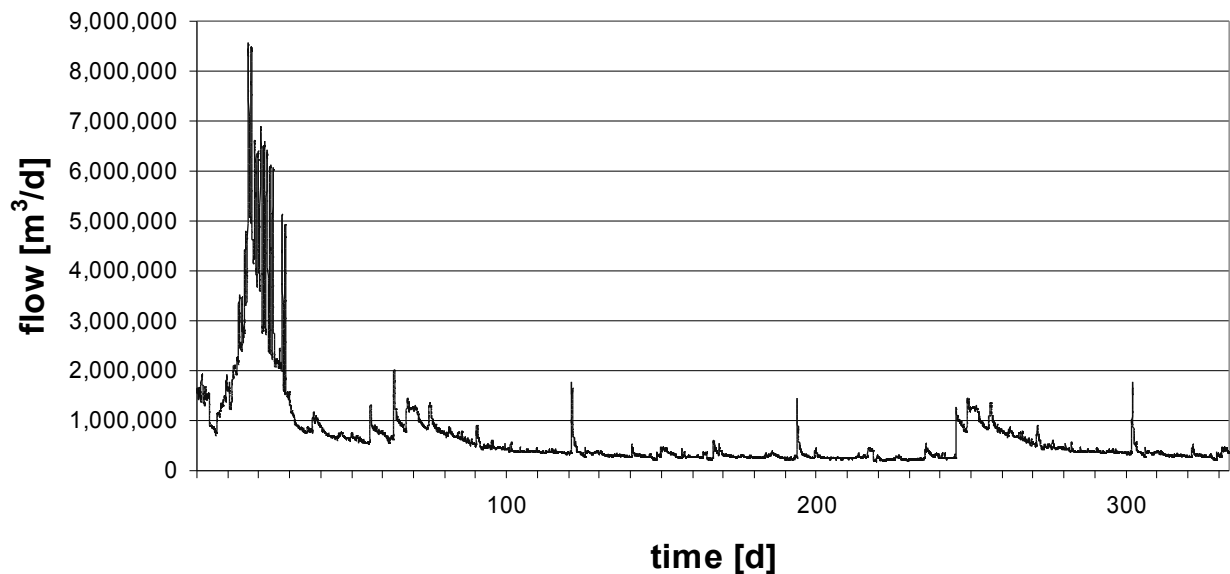

Figure 75: River upstream influent flow; from April to November.

The model used for river water quality processes is the one described above, with the default parameter values indicated in Reichert *et al.* (2001). Temperature dependency was introduced for some parameters by the following equation:

$$P_T = P_{T\_ref} \cdot e^{\beta_P \cdot (T - T\_ref)}$$

where  $P_T$  is the value of parameter  $P$  at temperature  $T$ ,  $P_{T\_ref}$  is the value of parameter  $P$  at the reference temperature  $T\_ref$  (20°C) and  $\beta_P$  is the temperature correction factor for parameter  $P$ . The temperature-dependent parameters and their associated temperature correction factors are listed

in Table 29 and are derived by Reichert *et al.* (2001).

The WWTP effluent – expressed in ASM2d state variables – is linked to the river model by means of the model interface described in Section 10.2.1.

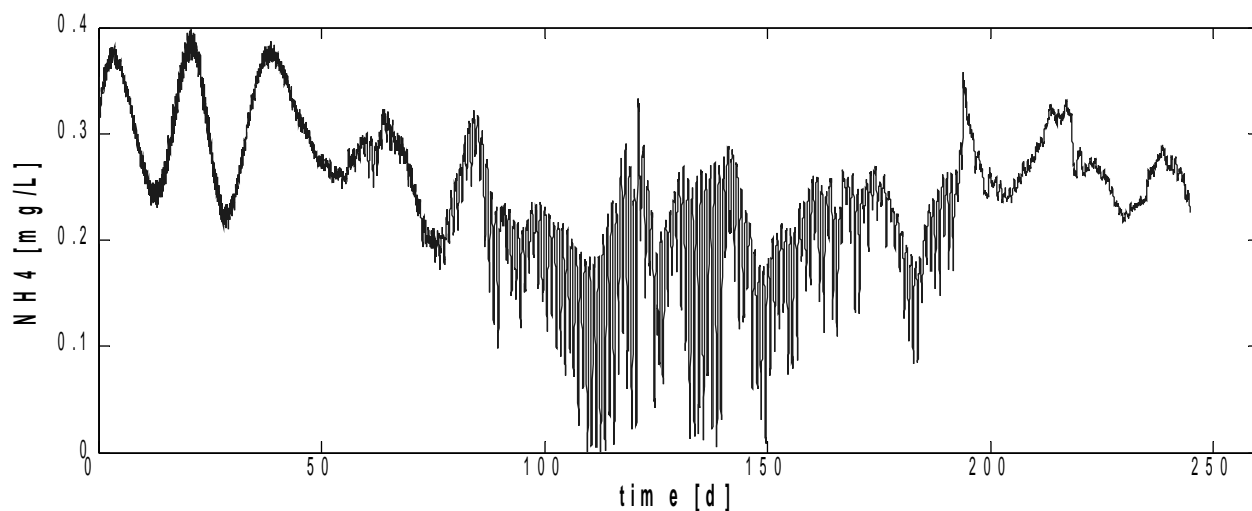

Figure 76: River upstream influent  $\text{NH}_4$  concentration; from April to November.

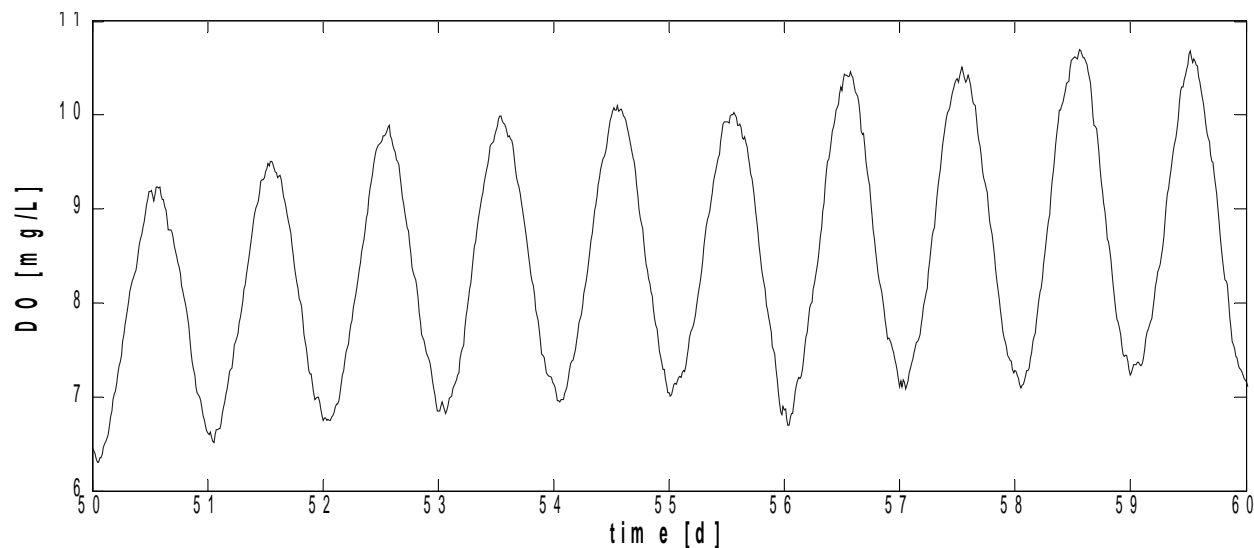

Figure 77: River upstream influent DO concentration; 10 days in May.

### Investigated scenarios

The investigated upgrade options were U0 (the reference case without upgrade), U2 (33% increase of activated sludge tanks and secondary settler) and U13, an upgrade option developed on purpose for the immission-based evaluation since its positive effects can only be seen with this

approach. It consists of an increase of treated flow in the activated sludge line from 2.5 to 5 times the DWF and an increase of the CSO threshold from 5 to 10 times DWF, so that the wastewater treated by the storm tank also increases. See Chapter 9 for information on U0 and U2 and Chapter 13 for the results of the investigation.

Table 29: Temperature-dependent parameters and their associated temperature correction factors  $\beta$ .

Parameter	Description	value [d <sup>-1</sup> ]	$\beta$ [-]
k_gro_H	Maximum heterotrophic aerobic growth rate	2	0.070
k_gro_N1	Maximum first-step nitrifiers growth rate	0.8	0.098
k_gro_N2	Maximum second-step nitrifiers growth rate	1.1	0.069
k_gro_ALG	Maximum algae growth rate	0.1	0.046
k_hyd	Hydrolysis rate	3	0.070

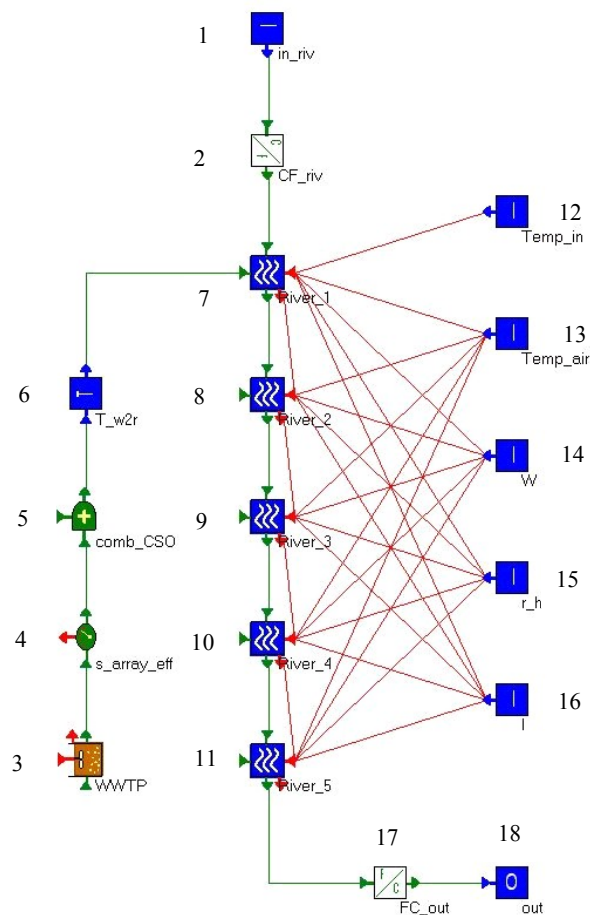

Figure 78: Integrated model of LLAS treatment plant and river; for node numbers explanation see Table 30.

Table 30: Legend for nodes of Figure 78.

Number	Name	Description
1	in_riv	Influent data input in terms of RWQM1 state variables.
2	CF_riv	Data transformer from concentrations to fluxes.
3	WWTP	It refers to the WWTP layout in Figure 66 until node 30 included.
4	s_array_eff	Array of sensors, measuring COD, TN, etc. in the combined effluent.
5	comb_CSO	Combiner of WWTP and storm tank effluents with the CSO spilling which in Figure 66 was “dumped” in node 5.
6	T_w2r	Data transformer from ASM2d to RWQM1 state variables.
7	River_1	Variable volume tank for river stretch.
8	River_2	Variable volume tank for river stretch.
9	River_3	Variable volume tank for river stretch.
10	River_4	Variable volume tank for river stretch.
11	River_5	Variable volume tank for river stretch.
12	Temp_in	Data input for water temperature.
13	Temp_air	Data input for air temperature.
14	W	Data input for wind speed.
15	r_h	Data input for relative humidity.
16	I	Data input for solar radiation.
17	FC_out	Data transformer from fluxes to concentrations.
18	out	Data output in terms of RWQM1 state variables.

### 10.3 Conclusions

In this chapter the modelling tools necessary to perform an immission-based evaluation of alternatives have been introduced and the implementation in WEST was described. A hypothetical river stretch – with a simplified version of RWQM1 for the water quality processes – was linked to the WWTP model – running ASM2d – by means of a model interface developed following the CBIM method. This integrated model was implemented for the evaluation (see Chapter 13) of three different upgrade options for the WWTP on the base of the receiving water quality.



## PROBABILISTIC ANALYSIS

*Parts of this chapter have been published as:*

**Benedetti, L., Bixio, D., Claeys, F. and Vanrolleghem, P.A. (2006).** *Tools to support a model-based methodology for benefit/cost/risk analysis of wastewater treatment systems, In: Proceedings of iEMSs 2006, Burlington, VT, USA, 10-13 July 2006.*

**Claeys, F., Chtepen, M., Benedetti, L., Dhoedt, B. and Vanrolleghem, P.A. (2006).** *Distributed virtual experiments in water quality management. Water Science and Technology 53(1), 297-305.*

**Claeys, F., Chtepen, M., Benedetti, L., De Keyser, W., Fritzson, P. and Vanrolleghem, P.A. (2006).** *Towards transparent distributed execution in the Tornado framework, In: Proceedings of Environmental Applications and Distributed Computing 2006, Bratislava, Slovakia, 16-18 October 2006.*

It is an increasingly common practice to use deterministic dynamic models to evaluate design and renovation scenarios of WWTPs. One of the remaining issues when dealing with these deterministic models is the degree of uncertainty linked to their predictions (see Figure 79).

Probabilistic design, which is the combination of probabilistic modelling techniques with the currently available deterministic models, provides a solution to this issue (Bixio *et al.*, 2002b). By building a probabilistic shell around the deterministic models one can quantify the uncertainty of the model predictions. For example, a goal can be to determine the probability of exceeding the legal effluent standards of a WWTP. This percentage of exceedance should be accompanied by confidence intervals indicating the uncertainty due to the variability of influent characteristics and to the uncertainty in model parameters.

This probabilistic analysis can be carried out by means of Monte Carlo simulation, which implies that large numbers of simulations and of output data need to be interpreted and summarised.

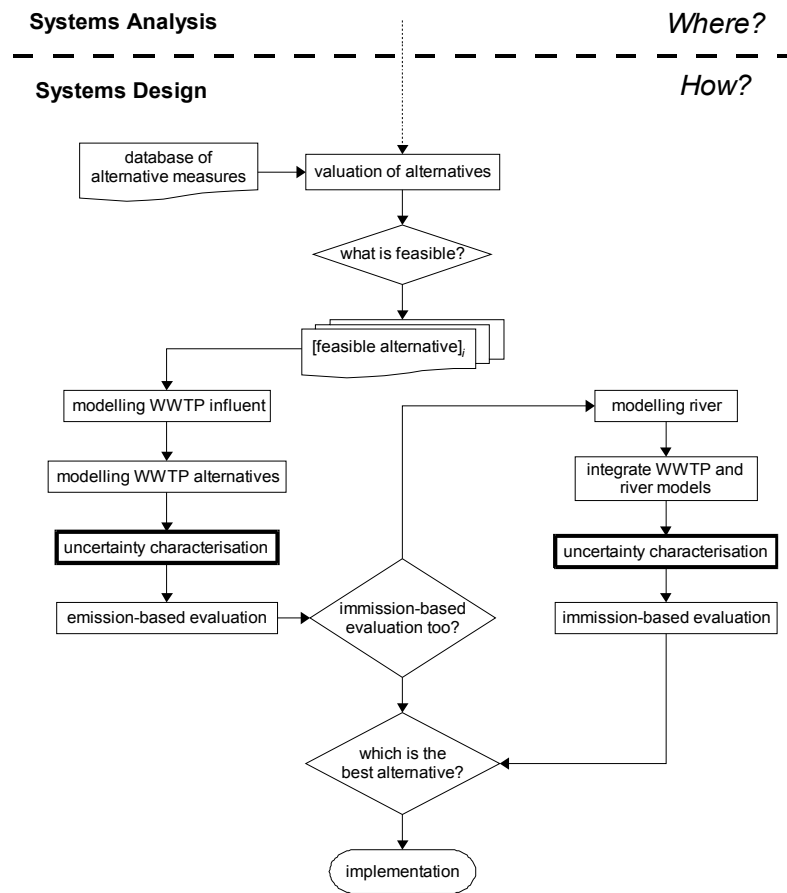

Figure 79: Uncertainty characterisation within Systems Design.

## 11.1 Tools

### 11.1.1 MONTE CARLO SIMULATION

The quantification of the uncertainty of the system as a whole by using Monte Carlo (MC) simulation may be carried out by the following procedure (Rousseau *et al.*, 2001), as illustrated in Figure 80:

1. assigning information about the probability distribution of each parameter and input variable in the system;
2. for every simulation with deterministic values, the simulator uses a specific value for each parameter and input variable (a “shot”) that is randomly selected by a MC engine from the appropriate probability density function (PDF). Over multiple simulations, the MC engine produces a range of values for the parameters and input variables that cover the probability density function;
3. the deterministic model is solved for each shot, as it would be for any deterministic analysis; all these simulations are independent from each other and can thus be run in



parallel.

This iterative process generates a probability density function or cumulative density function of the output. Based on the distribution of the output, a risk level representing the high end (e.g. 95<sup>th</sup> percentile), central tendency (median or mean), or any other desired level of probability can be evaluated.

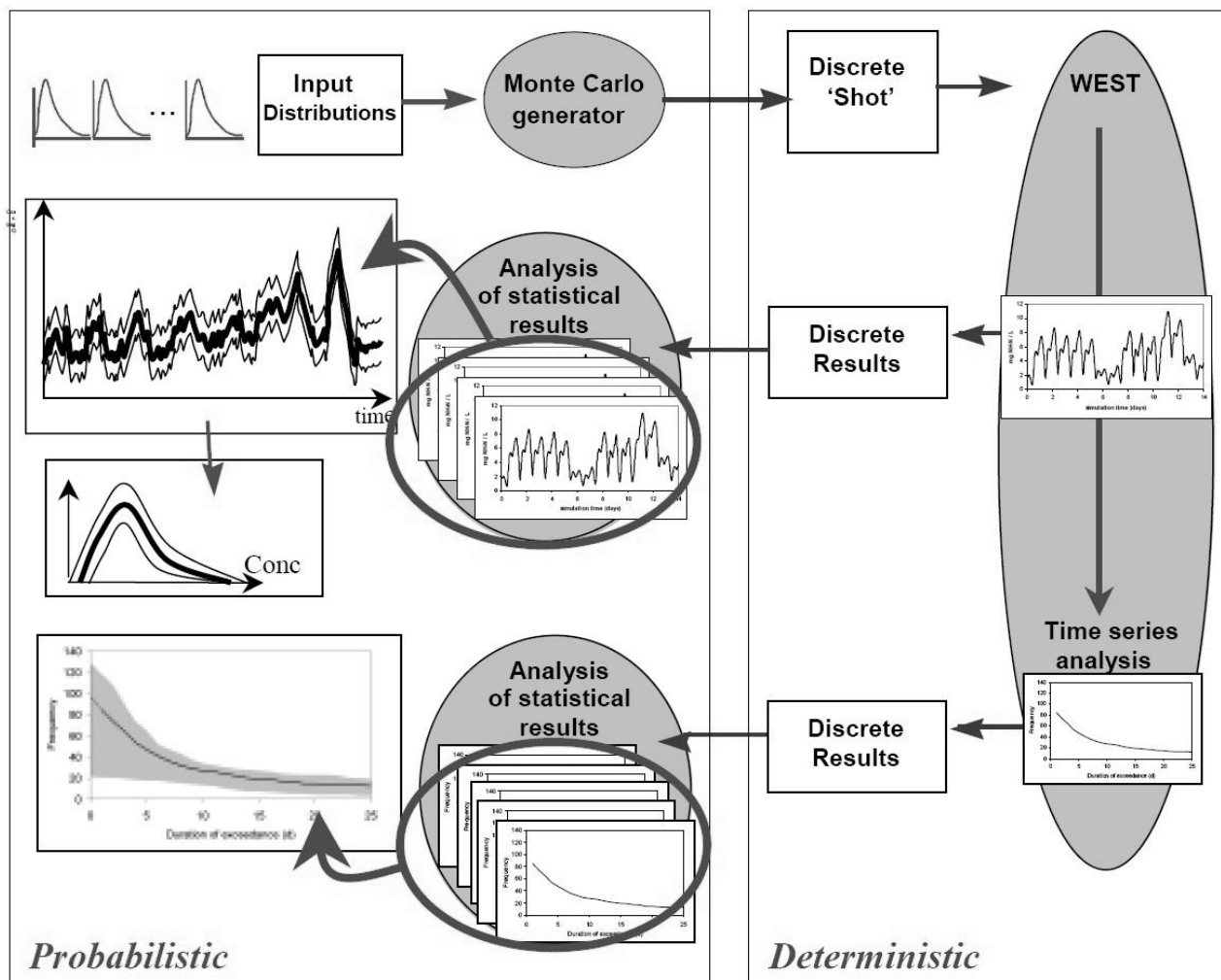

Figure 80: Monte Carlo simulation procedure.

### 11.1.2 DISTRIBUTED SIMULATIONS - TYPHOON

The number of necessary simulations with Monte Carlo-based uncertainty assessment tends to be large and each simulation of a treatment plant over one year under highly dynamic conditions may take considerable computation time. To reduce this computational burden, tools that distribute simulations over idling PCs available in a local network are under development and were used in this study (Claeys *et al.*, 2006a).

Historically, complex computational problems have often been tackled in a centralized manner, using super-computer infrastructures. However, with the advent of personal computers, interest in distributed architectures (such as clusters and peer-to-peer networks) has been steadily growing. It

was therefore suggested to take on the computational problem of virtual experiments (VEs) in a distributed manner.

A framework for the distributed execution of simulations on a potentially heterogeneous pool of work nodes (Linux/Windows) has been implemented. It was named “Typhoon” and has been built on top of technologies such as C++, XML (Extensible Markup Language, it is a text-based means to describe and apply a tree-based structure to information) and SOAP (Simple Object Access Protocol, it is a protocol for exchanging XML-based messages over a computer network). It was designed for stability, expandability, performance, platform-independence and ease of use.

### Requirements

The following are the requirements that were taken into account during the design and implementation of the Typhoon system:

- In order to be able to use distributed virtual experimentation – single virtual experiments (e.g. simulations) or compound experiments (e.g. optimizations, scenario analyses) – in several applications, it was to be conceived as a library (which offers the desired functionality to encapsulate applications) rather than as a stand-alone program.
- In practice, Typhoon will be mainly used to distribute the load of a complex VE over a number of (unused) work nodes that one has available at one’s organization. Most often (especially in the case of scientific/academic organizations), this pool of work nodes will be heterogeneous, in the sense that different hardware and operating systems will be used. Typhoon therefore had to be conceived as a cross-platform system that allows for interoperability.
- All types of VEs (single as well as composite experiments like MC simulation) should be remotely executable.
- During the remote execution of experiments, progress monitoring should be possible.
- As for any kind of distributed system, fail-safety is a key issue.
- Dynamic registration of work nodes is required. This means that additional work nodes should be able to register with Typhoon at run-time. Also, work nodes should be able to de-register at will. The latter may imply that experiments have to be rescheduled.
- Intelligent selection of experiments and work nodes is required.
- Since Typhoon is targeted towards a non-computer science user community, easy installation and use are very important. In fact, this requirement may in many cases outweigh the obvious performance requirement.
- In order to guarantee easy installation and use as well as cross-platform support, it is important for Typhoon to be based on as few third-party components as possible. Vendor and product independence can therefore also be stated as a requirement.
- The last requirement is one that has far-reaching consequences. In fact, it concerns the fact that – even if primarily intended for the execution of Tornado VEs – it should also be possible to apply the Typhoon framework to other types of problems (not necessarily related to water management or even simulation as such) leading to a need for application independence.

## Architecture

Typhoon consists of two main modules: Master and Slave. A Master receives requests for the execution of a number of Jobs from the user connected to the Application front-end (see Figure 81). The Master buffers the Jobs it receives and distributes them to a number of Slaves that have registered with the Master. Slaves perform the actual (possibly concurrent) execution of Jobs received from one or more Masters. The entity within the Master that performs the distribution of Jobs to Slaves was named Dispatcher. The entity within the Slave that awaits incoming Jobs was labelled Acceptor. For the actual transfer of data over the wire, traditional middleware solutions can be used. In order for the specifics of the middleware (software that connects software components or applications) not to be visible by the rest of the code, an abstraction layer was introduced.



Figure 81: High-level architecture of Typhoon.

## Typhoon versus Grid Computing

There are some obvious similarities between the Grid Computing paradigm (Fujimoto, 2000), which is recently receiving widespread attention and Typhoon. These similarities include the high-

level functionality (the distribution of a number of tasks over a number of work nodes), the importance of the fail-safety aspect and the fact that work nodes should be able to dynamically register and de-register.

However, there are also a number of differences between Grid Computing and Typhoon, which are important enough to justify the development of Typhoon. These differences include the following:

- Extent: Grid software is highly complex and goes far beyond what Typhoon attempts to deliver. As a result, the Typhoon code base is less than 50,000 lines of code whereas Grid software code bases are most often many times larger. The latter of course imposes a serious threat to the manageability and maintainability of Grid projects.
- Consistency: Typhoon was developed in a consistent manner, using as few third-party components as possible. Grid software on the other hand is built on top of a large number of external tools, thereby again hampering its manageability and maintainability.
- Installation: Typhoon installs in a matter of minutes. Installing Grid software is currently a lengthy and cumbersome experience.
- Intelligence: The intelligence claimed by Typhoon when distributing Jobs is quite limited at this point, but work is ongoing. In this respect Grid software – at least in theory – goes much further.
- Authentication: Typhoon is mainly intended for deployment within one organization. Issues such as security and confidentiality of data have therefore not been taken into account. Also in this respect, Grid software goes much further since it has a wider scope.
- Integration: Typhoon is conceived as a library that allows for straightforward integration into applications. Grid software is usually based on stand-alone servers and executables.
- Portability: Although most Grid software is intended to be portable, this proves not to be the case in practice (because of the many restrictions imposed by the external components that are used, security aspects, system performance monitoring aspects, etc.). Typhoon, however, was proven to be portable.

### 11.1.3 PROBABILISTIC DESCRIPTORS

The most immediate way to visualise the effluent dynamics is by means of time series. Because of the very pronounced dynamic behaviour of the simulation output time series – data every 15 minutes for one year – the picture can be difficult to interpret, but can also show features which are not otherwise evident. As can be seen in the ammonia time series of Figure 82, not much can be drawn from the picture. However, one can deduce for example that in winter (October to March, i.e. days from 90 to 230)  $\text{NH}_4$  has higher effluent peaks. On the other hand, zooming into the time series (see Figure 83) the daily dynamics and the associated uncertainty bounds can be clearly identified.

Better ways to interpret and summarise the large amount of data generated by the MC simulation have been developed and applied. Particularly suited to illustrate the uncertainty features of the results, are percentile polygons, the relative reliability index and concentration-duration curves, all described in the following.

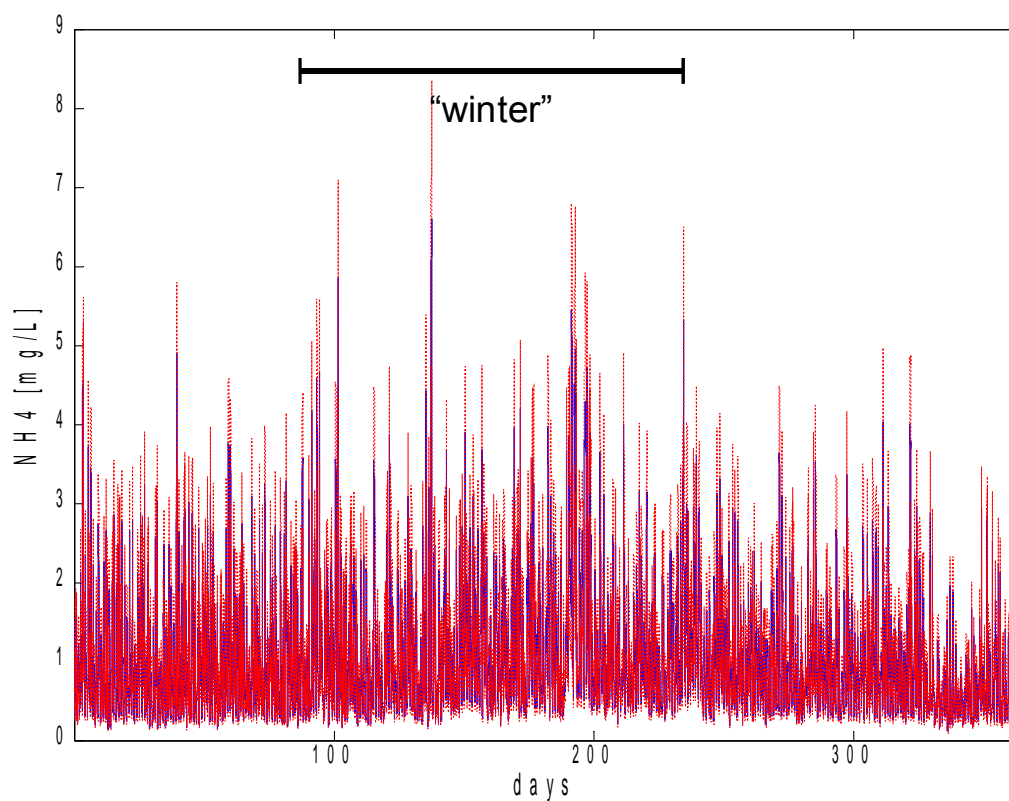

Figure 82: Time series for one year (July to June) of  $\text{NH}_4$  effluent for LLAS 30,000PE in Oceanic climate with 100% of ATV volume; 50<sup>th</sup> percentile (solid line) and 5<sup>th</sup> and 95<sup>th</sup> percentiles (dotted line).

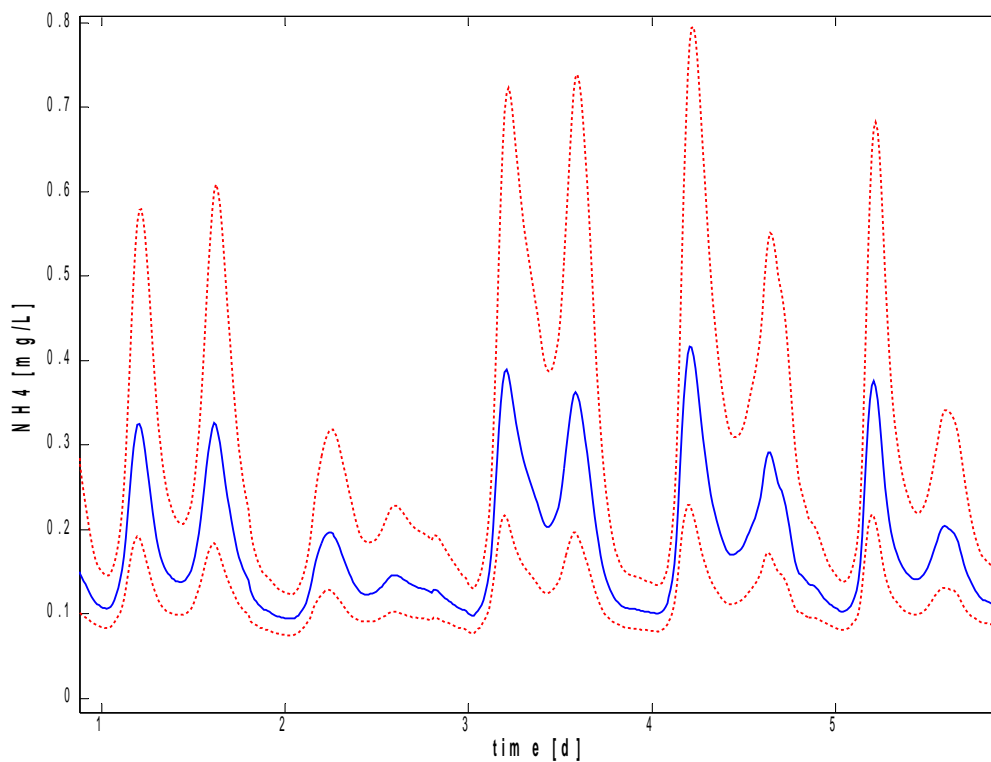

Figure 83: Time series for some days of  $\text{NH}_4$  effluent for LLAS 30,000PE in Oceanic climate with 100% of ATV volume; 50<sup>th</sup> percentile (solid line) and 5<sup>th</sup> and 95<sup>th</sup> percentiles (dotted line).

### Percentile polygons

One possibility to analyse the simulation output data is to calculate for each simulation the average (in this case over one year) for the interesting variables. For example, in Figure 84 (left side) the yearly averages of  $\text{NH}_4$  and of aeration energy cost (AEC) are plotted for each of the 100 MC simulations executed for each of the three different configurations, in this case LLAS for 30,000PE in Oceanic climate with three different aerated sludge volumes. Since the comparison does not appear straightforward due to the overlapping of the three clouds of 100 dots, it has been facilitated by the derivation of figures like Figure 84 (right side). Each of the polygons has been created by joining the 5<sup>th</sup> and 95<sup>th</sup> percentiles of the 100 data points calculated along the two principal axes found by using principal component analysis (PCA). The markers represent the 50<sup>th</sup> percentiles.

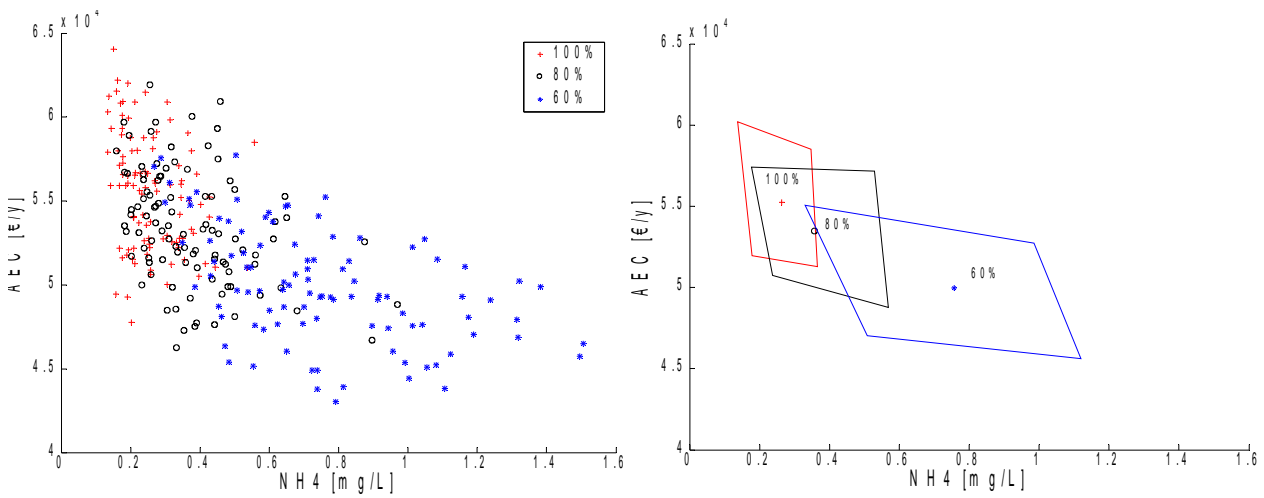

Figure 84: Two options to visualise Monte Carlo simulation results: all results as a cloud of markers (left) and polygons joining the 5<sup>th</sup> and 95<sup>th</sup> percentiles for the two variables and the 50<sup>th</sup> percentile as a marker (right); the data show effluent  $\text{NH}_4$  and aeration energy costs for different tank volumes for LLAS 30,000PE in Oceanic climate (for three percentages of ATV dimensioning volume: 60%, 80% and 100%).

### The relative reliability index (RRI)

An important criterion that has also been introduced is a measure to summarize the model output uncertainties: the relative reliability index (RRI). Starting from the yearly averages of a variable (e.g. 100 values as in the left side of Figure 84), the RRI is the average of that variable for all the configurations in the comparison divided by the standard deviation of the 100 values, to normalise the magnitude of the standard deviation. It is further normalised by dividing it by the average RRI for all configurations, so that the final values of the RRI have an average of 1:

$$RRI_{X^c} = \frac{\sum_{i=1}^n X_i^c / n}{\sigma_{X^c}} \bigg/ \frac{\sum_{j=1}^p \frac{\sum_{i=1}^n X_i^j / n}{\sigma_{X^j}}}{p}$$

where  $X$  is a variable (e.g. yearly average of COD),  $c$  is a configuration,  $n$  is the number of MC samples (100),  $\sigma_X^c$  is the standard deviation of variable  $X$  for configuration  $c$ , and  $p$  is the number of configurations (10).

It gives a measure of how stable the performance of the configuration is when it is subjected to variations in model parameters. It can be calculated for every single variable or for a combination of them (just by summing the RRI for the studied variables), e.g. in case of two variables the RRI is (inversely) related to the perimeter of the polygons in Figure 84 (right side) as can be seen in Figure 85.

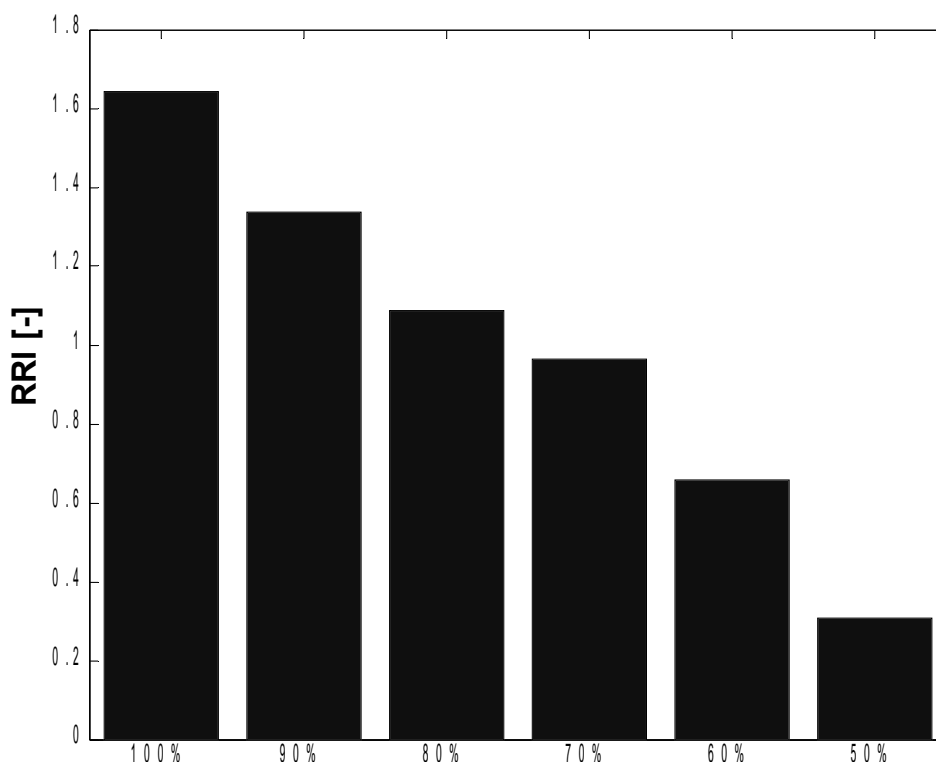

Figure 85: RRI for for  $\text{NH}_4$  and aeration energy cost for six different volumes of LLAS for 30,000PE in Oceanic climate.

### Concentration-duration curves

An instrument to assess the dynamic behaviour of the effluent (rather than only its average), is the concentration-duration curve. It allows to evaluate, for any given concentration value, the duration (in percentage of the total simulation period) for which that value has been exceeded. The use of MC simulations gives extra information on the uncertainty of such durations, as shown in Figure 86 (Rousseau *et al.*, 2001). An example of the information provided by Figure 86 is that one can say to be 50% sure that 15mgTN/l will be exceeded for not more than 13.7% of the total period (one year). To reach a confidence of 95%, the period of exceedance is estimated to be not more than 32.4% of the total period. While one can be only 5% sure that that threshold for TN will not be exceeded for more that only 6.3% of the total period.

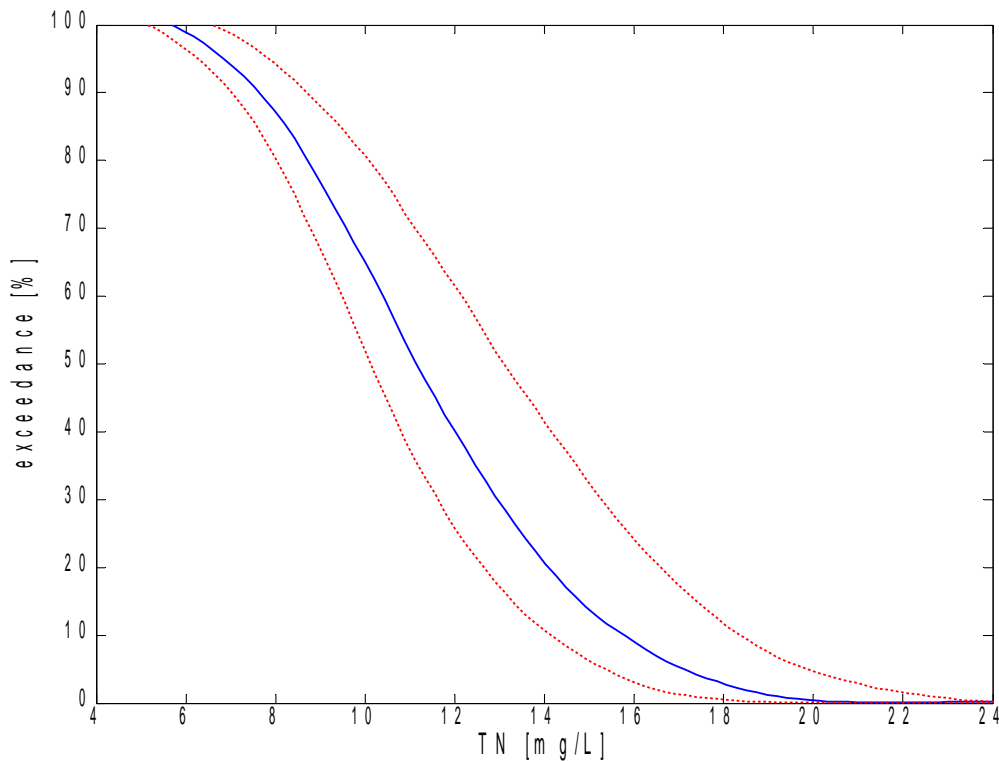

Figure 86: Concentration-duration curve of TN for LLAS 30,000PE in Oceanic climate with 60% of ATV volume; 50<sup>th</sup> percentile (solid line) and 5<sup>th</sup> and 95<sup>th</sup> percentiles (dotted line).

## 11.2 Scenarios

In this study, the modified ASM2d parameters considered as uncertain were chosen according to (Rousseau *et al.*, 2001) and to expert knowledge. Also, some parameters of the influent fractionation model are uncertain since the influent composition is considered as uncertain. The following parameters are listed with their statistical properties given in in Table 31:

- $f_{X_S}$ : fraction of particulate COD becoming slowly biodegradable particulate matter (in the influent fractionation model)
- $f_{S_F}$ : fraction of soluble COD becoming fermentable substrate (in the influent fractionation model)
- $\mu_H$ : maximum growth rate of heterotrophs
- $\mu_{AUT}$ : maximum growth rate of autotrophs
- $\mu_{PAO}$ : maximum growth rate of phosphorus accumulating organisms (PAOs)
- $\mu_H \_ b_H$ : ratio of maximum growth rate and decay coefficient for heterotrophs
- $\mu_{AUT} \_ b_{AUT}$ : ratio of maximum growth rate and decay coefficient for autotrophs
- $\mu_{PAO} \_ b_{PAO}$ : ratio of maximum growth rate and decay coefficient for PAOs
- $\eta_{NO3\_Hyd}$ : anoxic hydrolysis reduction factor
- $\eta_{NO3\_Hei}$ : reduction factor for denitrification



- $\eta_{NO3\_PAO}$ : reduction factor for anoxic activity for PAOs
- $K_{O\_AUT}$ : half saturation constant for oxygen of autotrophs
- $Y_{PO}$ : poly-phosphate requirement per PHA stored
- $\eta_{NO3\_Het\_d}$ : anoxic decay rate reduction factor for heterotrophs
- $\eta_{NO3\_P\_d}$ : anoxic decay rate reduction factor for PAOs
- $\eta_{NO3\_Aut\_d}$ : anoxic decay rate reduction factor for autotrophs

The parameters  $\mu_H\_b_H$ ,  $\mu_{AUT}\_b_{AUT}$  and  $\mu_{PAO}\_b_{PAO}$  have been introduced to take into account the correlation which is known to exist between the biomass maximum growth rate and the decay rate. The  $b$  parameters being calculated by dividing the  $\mu$  parameters by the  $\mu\_b$  parameters are also uncertain but correlated to the  $\mu$  parameters. No other parameter correlations have been considered in this study.

For each combination of plant configuration, size and climate, 100 parameter combinations were sampled from the parameter space using Latin Hypercube Sampling (LHS) (McKay, 1988) to perform the MC uncertainty assessment. This number of simulations was found to be sufficient to reach convergence of the simulation output distributions, being more than 7 times larger than the number of uncertain parameters. The minimum number of simulations to perform LHS is usually set as 4/3 of the number of parameters (McKay, 1988).

Table 31: Uncertain parameters listed with their statistical properties.

Name	Probability density function (PDF)	Mean (median)	Minimum	Maximum	Standard deviation	Unit
$f_{S\_F}$	triangular	0.375	0.3	0.45	-	-
$f_{X\_S}$	triangular	0.68	0.544	0.816	-	-
$\mu_H$	normal	6	4.8	7.2	0.4	d <sup>-1</sup>
$\mu_{AUT}$	normal	1	0.8	1.2	0.067	d <sup>-1</sup>
$\mu_{PAO}$	normal	1	0.8	1.2	0.067	d <sup>-1</sup>
$\mu_H\_b_H$	uniform	-	9.2	11.4	-	-
$\mu_{AUT}\_b_{AUT}$	uniform	-	4.6	5.7	-	-
$\mu_{PAO}\_b_{PAO}$	uniform	-	4.6	5.7	-	-
$\eta_{NO3\_Hyd}$	triangular	0.6	0.48	0.72	-	-
$\eta_{NO3\_Het}$	triangular	0.8	0.64	0.96	-	-
$\eta_{NO3\_PAO}$	triangular	0.6	0.48	0.72	-	-
$K_{O\_A}$	triangular	0.5	0.25	0.75	-	gO <sub>2</sub> m <sup>-3</sup>
$Y_{PO}$	triangular	0.4	0.32	0.48	-	gPgCOD <sup>-1</sup>
$\eta_{NO3\_Het\_d}$	triangular	0.5	0.4	0.6	-	-
$\eta_{NO3\_P\_d}$	triangular	0.33	0.264	0.396	-	-
$\eta_{NO3\_Aut\_d}$	triangular	0.33	0.264	0.396	-	-

## 11.3 Methodology evaluation

### 11.3.1 CONVERGENCE

In Figure 88, the convergence of the  $\text{NH}_4$  effluent for LLAS 30,000PE in Oceanic climate is shown. To obtain that graph, for each of the 100 simulations the  $\text{NH}_4$  concentration effluent time series (data each 15 minutes) is divided in 20 concentration intervals (classes) and the occurrences (frequencies) in each class are counted (see Figure 87 for a histogram for one of the 100 simulations). Then the average frequency in each of the 20 classes for the first  $i$  simulations is plotted against  $i$  (the lines in Figure 88), with  $i$  from 1 to 100. When the average frequencies stabilise around some values, convergence is reached. In our case, this appears to have already happened with less than 100 simulations except for the least frequent classes. The 20 classes are centred at values from  $1.2\text{gNH}_4/\text{m}^3$  (class 1 and most frequent) to  $5.1\text{gNH}_4/\text{m}^3$  (class 20 and least frequent).

The discontinuities – evident especially with low-frequency classes (high values of  $\text{NH}_4$ ) and with small number of simulations (left side of the graphs in Figure 88) – are caused by simulations which are characterised by particularly high  $\text{NH}_4$  average throughout the year, which strongly increase the frequency of medium and low frequency classes when the average is calculated on a small number of simulations.

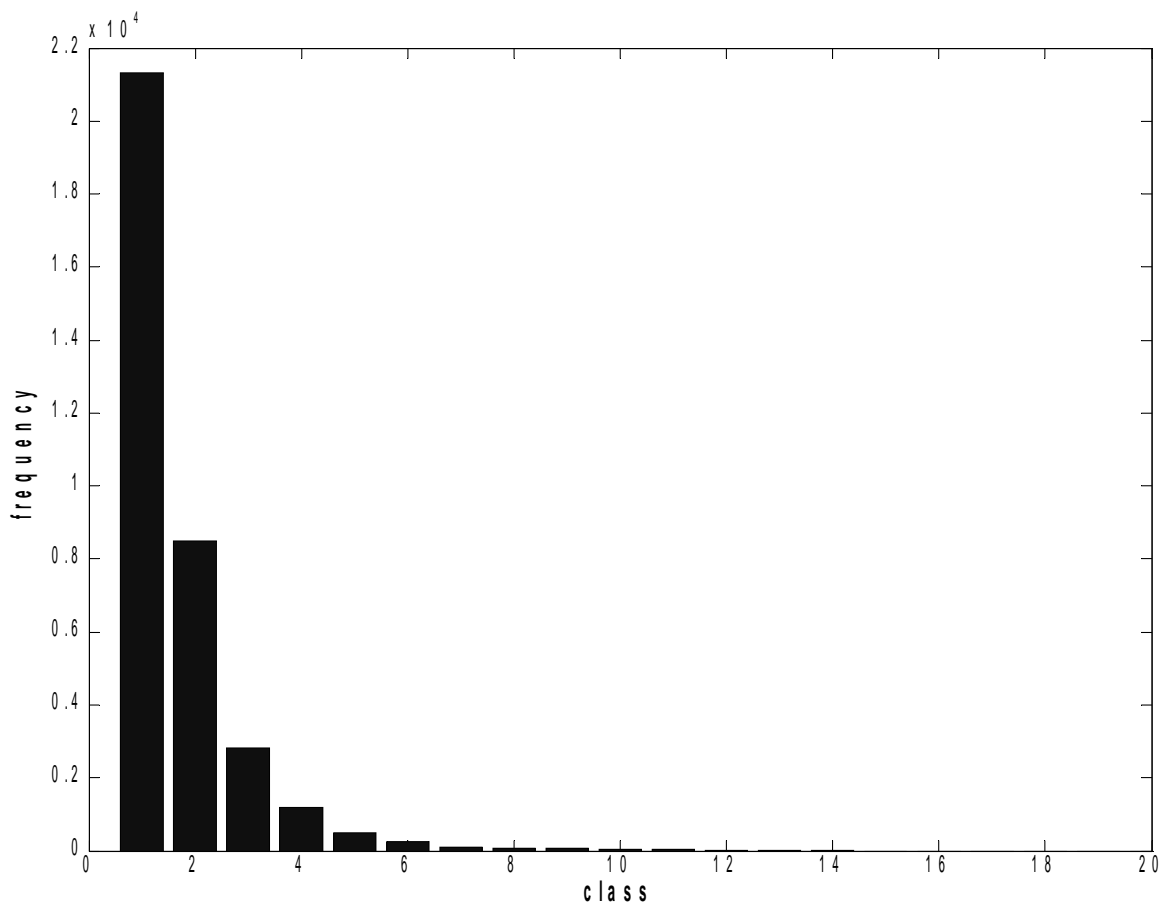

Figure 87: Histogram for frequencies of  $\text{NH}_4$  in one of the 100 simulations for LLAS 30,000PE in Oceanic climate.

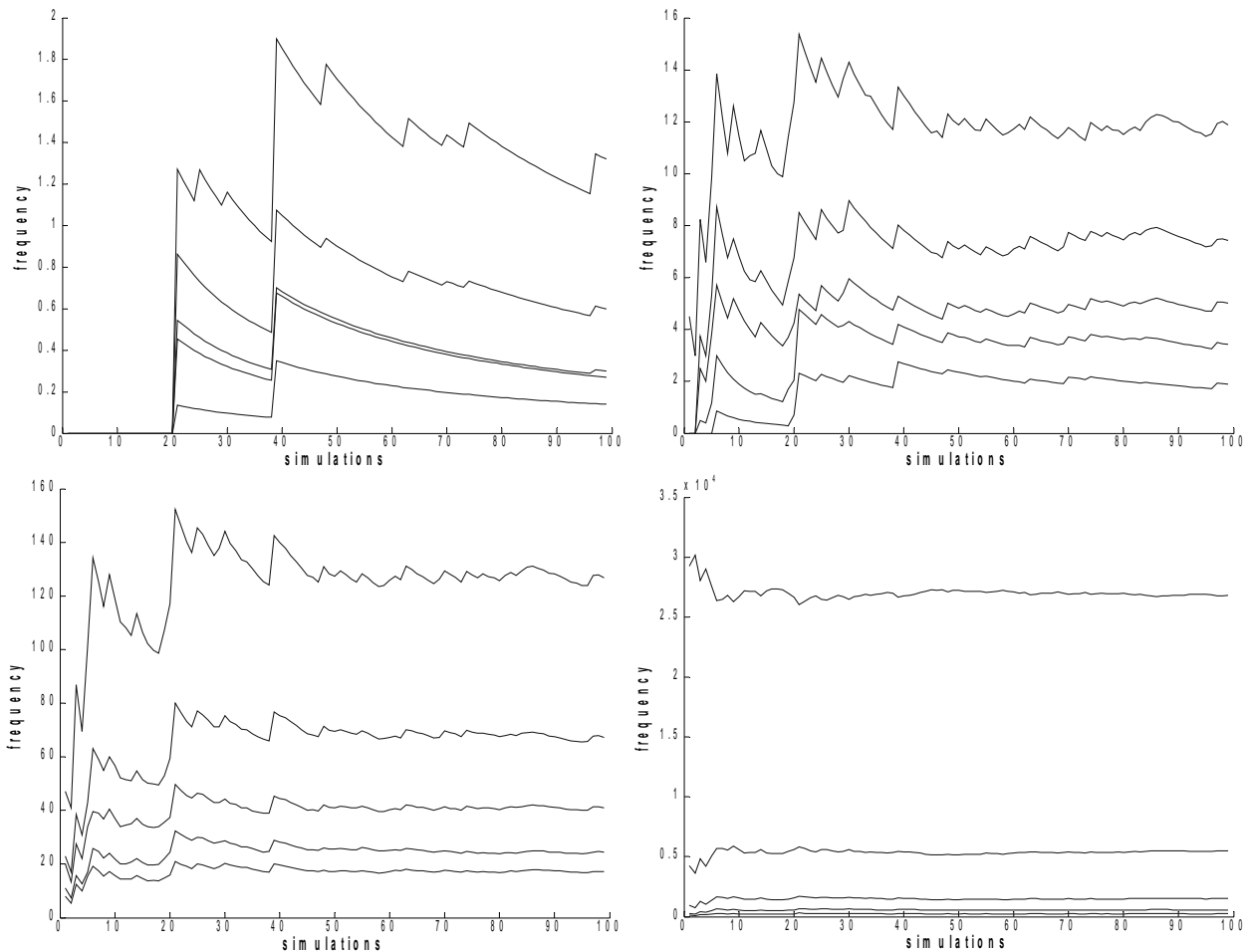

Figure 88: Convergence for 20 classes of  $\text{NH}_4$  output for LLAS 30,000PE in Oceanic climate; from left to right and from top to bottom: classes 16-20, 11-15, 6-10 and 1-5.

### 11.3.2 SENSITIVITY TO PROBABILITY DENSITY FUNCTION

Another issue is the choice of the probability density function (PDF) for each of the uncertain parameters. To assess the importance of this issue, a MC uncertainty analysis was performed for the Biedenipho configuration for 300,000PE in Oceanic climate with two different PDFs (Table 31 and Table 32). From Figure 89 to Figure 91 the results of the comparison between the two MC analyses with two different PDF sets are shown.

It is evident that the alternative PDF set leads to more uncertain outputs. This result was expected since in the alternative PDF set there are more uniform distributions than in the original set. Uniform distributions contain less information (more uncertainty) than triangular or normal distributions, therefore more uncertainty is propagated in the simulation outputs. This leads to conclude that care should be taken in choosing the PDFs for the MC analysis and that in general in case of little information on the parameters, it is advisable to adopt uniform distributions in order not to underestimate the model prediction uncertainties.

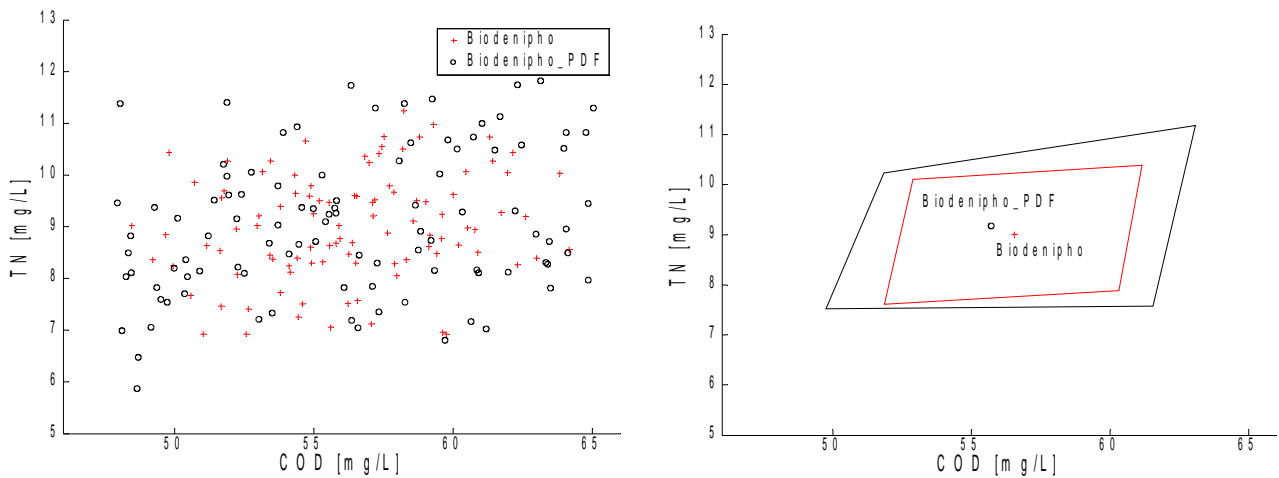

Figure 89: COD and TN average concentrations for two different PDF sets for BIODENIPHO 300,000PE in Oceanic climate as cloud of dots (left) and as percentile polygons (right); in the legend, Biodenipho is with the normal PDF set and Biodenipho\_PDF with the alternative PDF set.

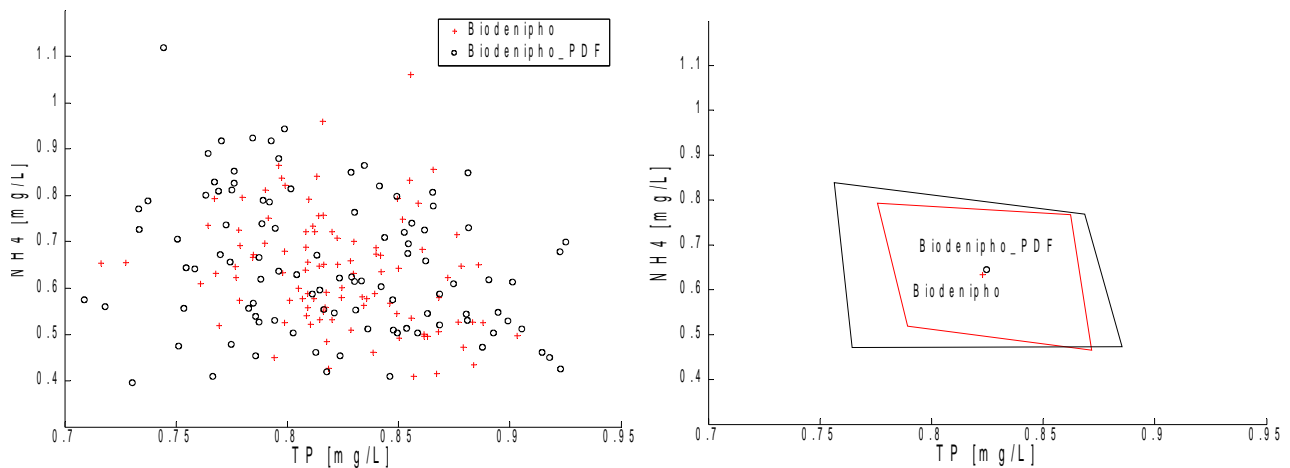

Figure 90: TP and NH<sub>4</sub> average concentrations for two different PDF sets for BIODENIPHO 300,000PE in Oceanic climate as cloud of dots (left) and as percentile polygons (right); in the legend, Biodenipho is with the normal PDF set and Biodenipho\_PDF with the alternative PDF set.

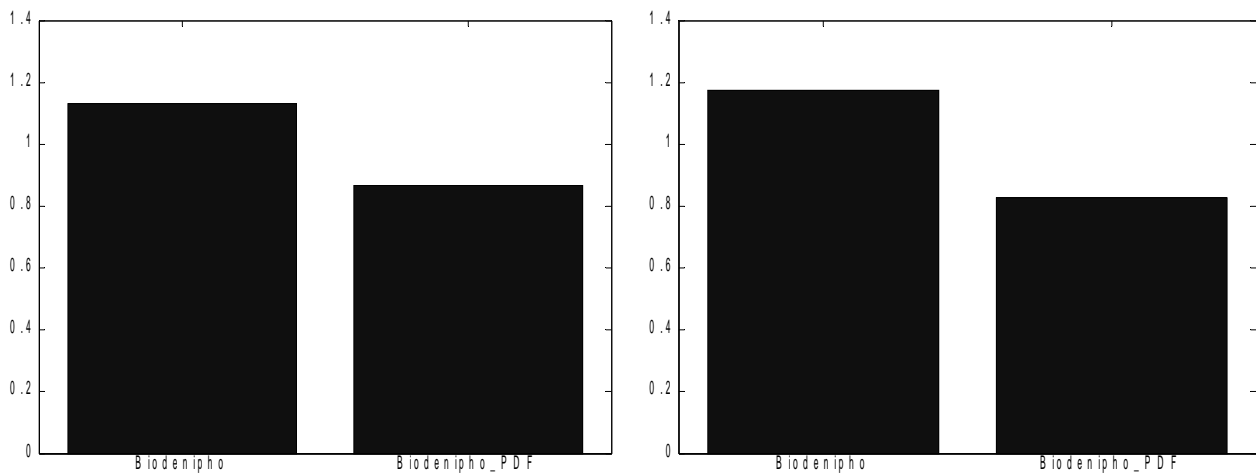

Figure 91: RRI for two different PDF sets for Biodenipho 300,000PE in Oceanic climate for all variables (left) and for COD only (right); Biodenipho is with the normal PDF set and Biodenipho\_PDF with the alternative PDF set.

Table 32: Uncertain parameters with alternative PDFs.

Name	Probability density function (PDF)	Mean (median)	Minimum	Maximum	Standard deviation	Unit
$f_{S\_F}$	uniform	-	0.3	0.45	-	-
$f_{X\_S}$	uniform	-	0.544	0.816	-	-
$\mu_H$	triangular	6	4.8	7.2	-	$d^{-1}$
$\mu_{AUT}$	triangular	1	0.8	1.2	-	$d^{-1}$
$\mu_{PAO}$	triangular	1	0.8	1.2	-	$d^{-1}$
$\mu_H b_H$	triangular	10	9.2	11.4	-	-
$\mu_{AUT} b_{AUT}$	triangular	5	4.6	5.7	-	-
$\mu_{PAO} b_{PAO}$	triangular	5	4.6	5.7	-	-
$\eta_{NO3\_Hyd}$	uniform	-	0.48	0.72	-	-
$\eta_{NO3\_Het}$	uniform	-	0.64	0.96	-	-
$\eta_{NO3\_PAO}$	uniform	-	0.48	0.72	-	-
$K_{O\_A}$	uniform	-	0.25	0.75	-	$gO_2m^{-3}$
$Y_{PO}$	uniform	-	0.32	0.48	-	$gPgCOD^{-1}$
$\eta_{NO3\_Het\_d}$	uniform	-	0.4	0.6	-	-
$\eta_{NO3\_P\_d}$	uniform	-	0.264	0.396	-	-
$\eta_{NO3\_Aut\_d}$	uniform	-	0.264	0.396	-	-

### 11.3.3 CALCULATION BURDEN OF SIMULATIONS

A cluster of 16 Linux machines with 3GHz processors at BIOMATH with Typhoon and the Ghent University Grid with 52 nodes – with the software LGC-2 used to distribute the simulations – were available for this work.

To show how the feasibility of the proposed methodology of probabilistic analysis is dramatically increased by the development and use of Typhoon, Figure 92 shows the comparison of the execution of a batch of 100 Monte Carlo simulations of the LLAS model for 30,000PE with the latest version of WEST used in this study, Tornado, with the BIOMATH cluster using Typhoon and on the Ghent University grid using LGC-2.

It is apparent that the distribution of parallel simulations to a group of available PCs gives a major reduction in calculation time. The use of a large grid with many nodes is of course beneficial, but the above mentioned disadvantages of using grid software instead of Typhoon should also be taken into account in the choice of the distribution tool.

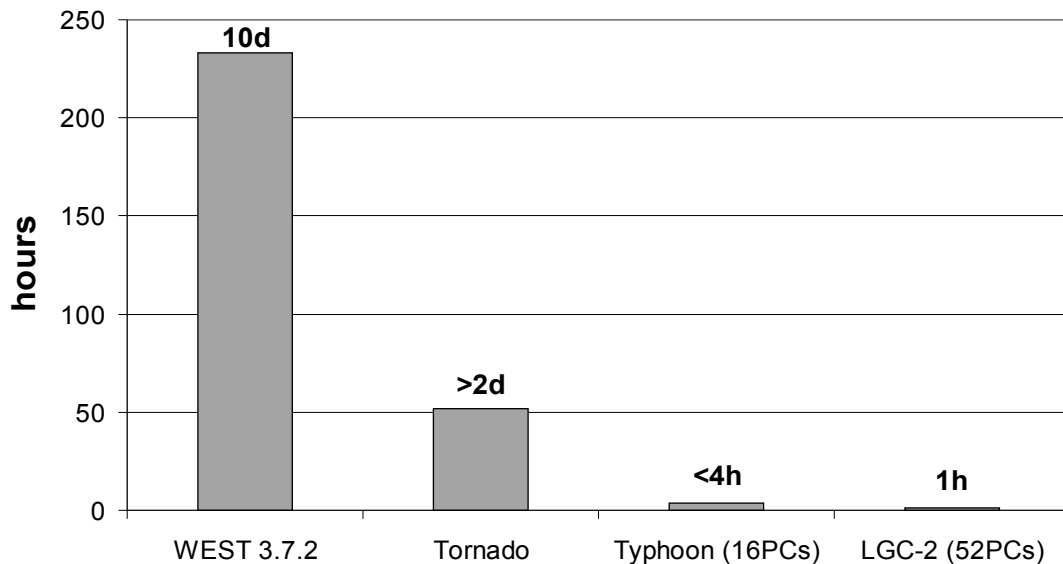

Figure 92: Execution time for an MC simulation using different tools.

## 11.4 Conclusions

In this chapter, the probabilistic analysis approach by means of MC simulation was introduced. Several tools and methods have been developed for the purpose, including a set of descriptors for uncertainty analysis. Typhoon – a software that distributes parallel simulations to computers in a grid or cluster and dramatically reduces the execution time of parallel simulations – was tested and adapted to perform MC simulation.

The parameter uncertainty characterisation and propagation adopted in this study to design and upgrade WWTPs was presented and the methodology proved to be feasible, after evaluation of the required simulation time, the convergence of the MC simulation with the adopted number of samples and the sensitivity of the results due to different assumptions on the probability density functions of the model parameters.

## EMISSION-BASED EVALUATION OF ALTERNATIVES

*Parts of this chapter have been published as:*

**Benedetti, L., Bixio, D. and Vanrolleghem, P.A. (2006).** *Assessment of WWTP design and upgrade options: balancing costs and risks of standards' exceedance. Water Science and Technology 54(6-7), 371-378.*

**Benedetti, L., Bixio, D. and Vanrolleghem, P.A. (2006).** *Benchmarking of WWTP design by assessing costs, effluent quality and process variability. Water Science and Technology 54(10), 95-102.*

A necessary step in the performance assessment of treatment alternatives (see Figure 93) in any present-day regulation is the evaluation of the effluent quality (emissions). In the WFD, this is part of the so-called “combined approach”, completed by the evaluation of water quality (immission).

This chapter deals with the presentation of the emission-based evaluation framework – divided in environmental and economic performance – and shows the results of the comparison of alternatives for WWTP design and upgrade carried out for this dissertation. Several contexts are investigated, starting with the comparison of different activated sludge volumes for a single process configuration.

Afterwards, the performance of ten configurations is studied to quantify which process types perform better for the different purposes and which is their performance reliability (uncertainty). For the comparison of the ten configuration, an analysis is also carried out concerning the sensitivity of the results towards a restriction of the simulated time period from one year to the winter season only and towards the adoption of a different set of cost parameters.

The last comparison is made between twelve different upgrade options for a single process configuration, involving both construction of treatment volumes and implementation of real-time control systems.

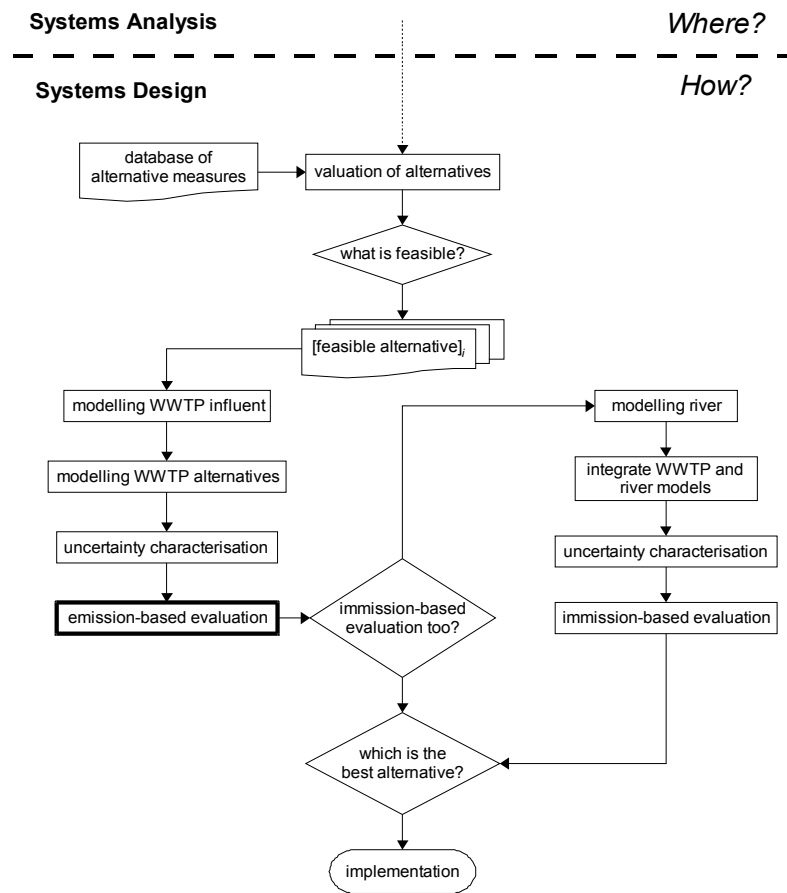

Figure 93: Emission-based evaluation within Systems Design.

## 12.1 Evaluation framework

The comparison of alternative scenarios is based on performance criteria that are grouped into two categories: environmental and economic criteria. The weight attributed to them in the decision making process depends on the specific situation of the case at hand and should be left to the decision maker (e.g. the politician), not to the decision facilitator (e.g. the engineer).

### 12.1.1 ENVIRONMENTAL PERFORMANCE

The proposed methodology is based on the approach set out by IWA and the EU COST-Action (Copp *et al.*, 2002). It consists of the evaluation of the effluent quality index (EQI) and of the COD, TN, TP and NH<sub>4</sub> effluents independently. The EQI is meant to quantify the effluent pollution load to a receiving water body in a single variable. The EQI is the weighted sum over one complete year of the pollution loads due to:

- total suspended solids (TSS)
- chemical oxygen demand (COD)



- biological oxygen demand after 5 days (BOD<sub>5</sub>)
- total nitrogen (TN)
- total phosphorus (TP)

The used weights (see Table 33) are based on (Vanrolleghem *et al.*, 1996) that cited a Flanders' effluent quality formula for calculating fees (Copp *et al.*, 2002).

Table 33: Weights for EQI calculation.

	TSS	COD	BOD <sub>5</sub>	TN	TP
weight	2	1	2	20	100

The EQI was used to derive percentile polygons and RRI (see Section 11.1.3), while for the four analysed pollutants also the exceedance of certain thresholds was calculated.

Effluent violations were calculated for TN and TP assuming the limits contained in the EU wastewater directive (CEC, 1991):

- TN: limit to 15mg/l for 3,000PE and 30,000PE and 10mg/l for 300,000PE;
- TP: limit to 2mg/l for 3,000PE and 30,000PE and 1mg/l for 300,000PE.

The percentage of time that the constraints are not met is calculated from the output data generated at 15-minute intervals.

## 12.1.2 ECONOMIC PERFORMANCE

The evaluation of costs for wastewater treatment is very complex. In a European context, costs can differ among countries or regions because of different specific conditions and also because of differences in planning and building procedures (Bode and Lemmel, 2001). This complexity makes the approach to calculate costs in order to compare different plant configurations and operational strategies very difficult.

Detailed cost calculations should in general be preferred over the use of cost functions, which can only be useful for rough estimations. Most WWTPs are tailored to specific conditions/needs, i.e. plants with the same treatment performances do not inevitably lead to the same costs. The use of cost functions is feasible only for process options screening (Gillot *et al.*, 1999), i.e. as it is the case here. In this work, operating costs have been estimated with the benchmark assessment procedure (Copp *et al.*, 2002) and with prices representative for northern Europe, while the capital costs were calculated with cost functions.

A detailed description about the way calculations were performed makes the assessment more transparent and comparable with other studies or available data. The main focus of this study is the water treatment line, while sludge treatment was considered with less detail.

The cost categories used in this study are:

- aeration energy cost (AEC);
- energy cost (EC) including aeration, pumping and mixing costs;
- sludge cost (SC) which comprises sludge treatment and disposal;

- variable cost (VC) incorporating energy, sludge and chemicals cost;
- total cost (TC) which includes variable, personnel, maintenance and annualised capital costs.

All the cost figures provided below and not clearly referenced, were provided by Aquafin as personal communication. Since capital costs information was available for Germany, also the operational costs were given for the same country.

Capital costs for the construction of tanks and for the associated mechanical equipment were calculated as function of the volume and of purpose (aeration, settling, etc.), using cost functions valid for Germany (Bohn, 1993; ATV, 1995; Günthert and Reicherter, 2001). Such capital costs were annualised using a service life of 30 years for the civil works and 15 years for the mechanical equipment and an interest rate of 4%. Associated to capital costs are annual maintenance costs for civil works and mechanical equipment, estimated as 0.5% and 3% per year respectively.

The personnel requirement was estimated to be 1, 3 and 8 people for the 3,000PE, 30,000PE and 300,000PE plants respectively (ATV, 1995), with an associated cost of 50,000€ per person per year. Personnel costs are the same for all configurations, since they were assumed to be a function only of plant size and not of plant type.

Operational costs are considered through the following items (ATV, 1995; MURL, 1999):

- sludge treatment;
- pumping energy;
- aeration energy;
- mixing energy;
- chemicals consumption.

For sludge production some assumptions have been made on the sludge treatment and disposal for the three plant sizes, estimating operational costs on the basis of the cubic meters of sludge pumped out of the water line for sludge treatment and on the tons of dry solids for sludge disposal (see Table 34). Capital costs for sludge treatment are not considered.

Table 34: Sludge costs; VC = variable cost.

Size [PE]	Treatment	VC [€/m <sup>3</sup> ]	Disposal	VC [€/tonDS]
3,000	gravity thickener	0.1	treatment in bigger plant + incineration	200
30,000	thickening table + centrifuge	1.2	incineration	100
300,000	thickening table + centrifuge	0.6	incineration	100

The aeration energy (AEn) in kWh/y was calculated as:

$$AEn = kLa \cdot S^* \cdot V / AEf / 1000 \cdot 365$$

where  $kLa$  is the oxygen transfer rate (obtained from the simulations) in  $d^{-1}$ ,  $S^*$  is the difference between the oxygen concentration at saturation and the one in the aerated tank (both obtained from the simulations) in  $gDO/m^3$ ,  $V$  is the tank volume in  $m^3$  and  $AEf$  is the aeration efficiency of the equipment at process conditions, assumed to be  $1.5kgDO/kWh$  (for fine bubble aeration); it is

known that the latter parameter varies as a function of other quantities (e.g. temperature), but it was decided to keep it constant throughout the year to simplify the evaluation and to be consistent with the overall level of complexity in the cost calculations.

Pumping energy resulted from the simulated flows to be pumped, assuming a head loss of 0.8m for mixed liquor recirculation and 2m for secondary sludge recirculation.

Mixing energy was assumed to be  $2W/m^3$  of volume to be mixed.

The cost of energy has been fixed to 0.1€/kWh.

As for chemicals, the cost associated to P-precipitant was assumed to be 100€/m<sup>3</sup> for 3,000PE and 65€/m<sup>3</sup> for 30,000 and 300,000PE; for C-source the cost was 70€/m<sup>3</sup>. It is to be noted that the cost of C-source can vary significantly as a function of which industries with C-based by-products are close to the WWTP and could provide such substances at low price.

To investigate how the above mentioned cost factors affect the comparison of configurations, also an alternative set of costs has been used for the 300,000PE in Continental climate, with costs that would be representative of Eastern European countries. The different factors in the two sets are shown in Table 35. All other costs are left the same. It is expected that capital costs are also different in the two areas, but no information was available on the issue.

Table 35: Two different cost sets for 300,000PE.

	Germany	Eastern Europe	
personnel units	8	20	[-]
personnel cost	50,000	15,000	[€/unit/y]
sludge disposal	100	30	[€/tonDS]
energy cost	0.1	0.07	[€/kWh]
interest rate	4	6	[%]

## 12.2 Results

### 12.2.1 WWTP DESIGN

As a first context for evaluation of alternatives, taking the LLAS plant for the 30,000PE in Oceanic climate as an example, a comparison of different activated sludge volumes is performed.

Then, one of the 12 combinations of climate and plant size is examined in detail (30,000PE for Oceanic climate) to illustrate the options for process comparison, while for the others only a general comparison is provided.

An example of seasonal analysis is given, limiting the investigated period to winter for the 300,000PE in Continental climate, to focus on the performance during the most difficult period for nitrification.

The sensitivity to cost parameters is then explored by comparing the two alternative set of values mentioned above for the 300,000PE in Continental climate.

## Volume comparison

### *Discussion*

The first type of comparison made consisted of choosing a process and evaluating its performance with different dimensioning or operational parameters, e.g. volumes, recycle rates, controllers set-points, etc.

In this section, the LLAS process for 30,000PE in Oceanic climate has been chosen as an example, showing the effect of different activated sludge volumes. The reference case is taken by dimensioning the volumes according to the ATV guidelines (ATV, 2000), referred as 100%, while the other volumes were just 90%, 80%, 70%, 60% and 50% of the ATV volume, leading to smaller capital costs. It is important to note that the MLSS in the tanks is kept constant, so that by decreasing the volume the SRT is decreased as well.

In the box plots (Figure 104 to Figure 111), the lower and upper lines of the box are the 25<sup>th</sup> and 75<sup>th</sup> percentiles of the sample. The distance between the top and bottom of the box is the interquartile range. The line in the middle of the box is the sample median. If the median is not centred in the box, that is an indication of skewness. Values that are more than 1.5 times the interquartile range away from the top or bottom of the box are represented by markers.

From Figure 94, the EQI of the six design volumes is approximately the same, while total costs are lower for smaller volumes and uncertainties do not appear to vary significantly, as confirmed by the RRI results shown in Figure 100 and Figure 101 for EQI and TC respectively and by the efficiency of TC for quality index removed in Figure 104. The QI removed is derived as the influent quality index minus the EQI. The influent quality index is calculated by summing the WWTP influent pollutant loads by using the same weights as for the EQI (Table 33).

Also COD removal does not have a significant trend (Figure 95 and Figure 108), while variable costs increase with decreasing volume (Figure 105). This is due only to the increased sludge production with smaller volumes (Figure 97 and Figure 107) while energy costs are smaller with smaller volumes (Figure 96 and Figure 106) since most of the energy costs (aeration) is proportional to the volume of a specific aerated tank. Figure 102 and Figure 103 summarise the results regarding costs.

TN removal tends to decrease with smaller volume (Figure 96 and Figure 109), because of the smaller nitrification capacity of the plant, which is very evident in Figure 98 and in Figure 111. On the other hand, TP removal improves with smaller volumes (Figure 97 and Figure 110), due to the larger TP quantity removed with sludge.

As for the overall stability of the process (Figure 99), the RRI for all variables is smaller with decreasing volumes, but only for the 50% volume it looks significantly smaller especially due to the lower stability of the NH<sub>4</sub> removal (Figure 98 and Figure 111).

### *Conclusions*

It can be concluded that building activated sludge volumes smaller than the ones traditionally calculated by applying design guidelines leads to considerable total cost reductions, while it entails only a small increase in the risk of not complying with emission standards for yearly averages. The reduction can in this case go down to 60% of the ATV volume, which actually corresponds to the safety factor implicit in the ATV guidelines for that plant size.

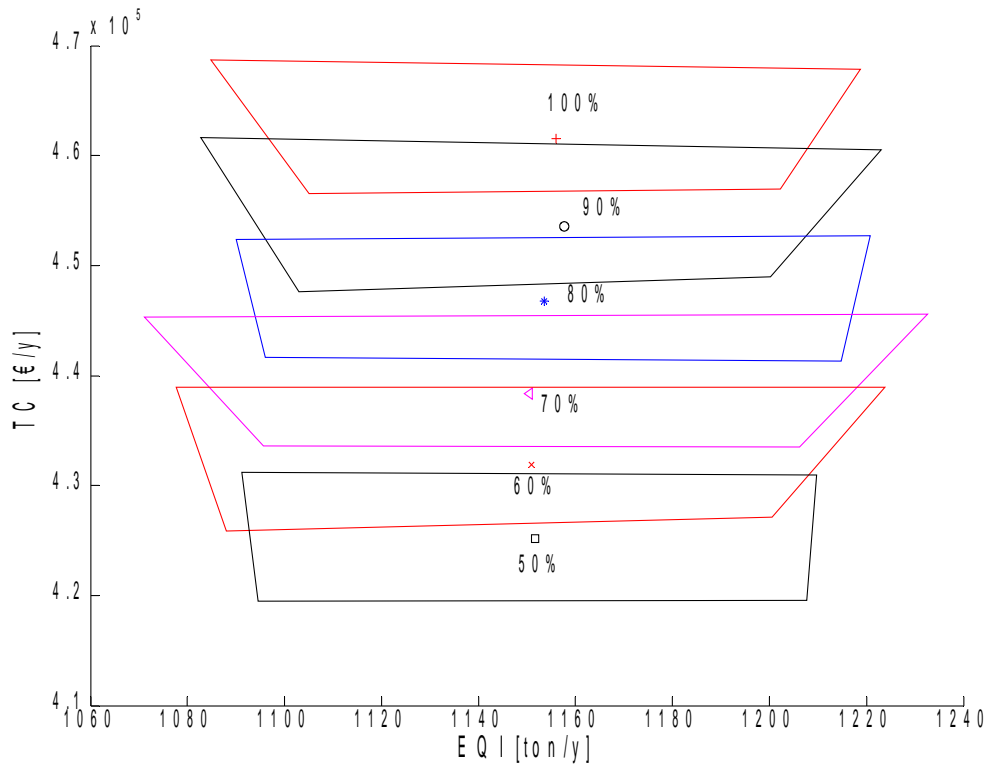

Figure 94: EQI and TC for LLAS 30,000PE in Oceanic climate for different volumes (as % of ATV volume).

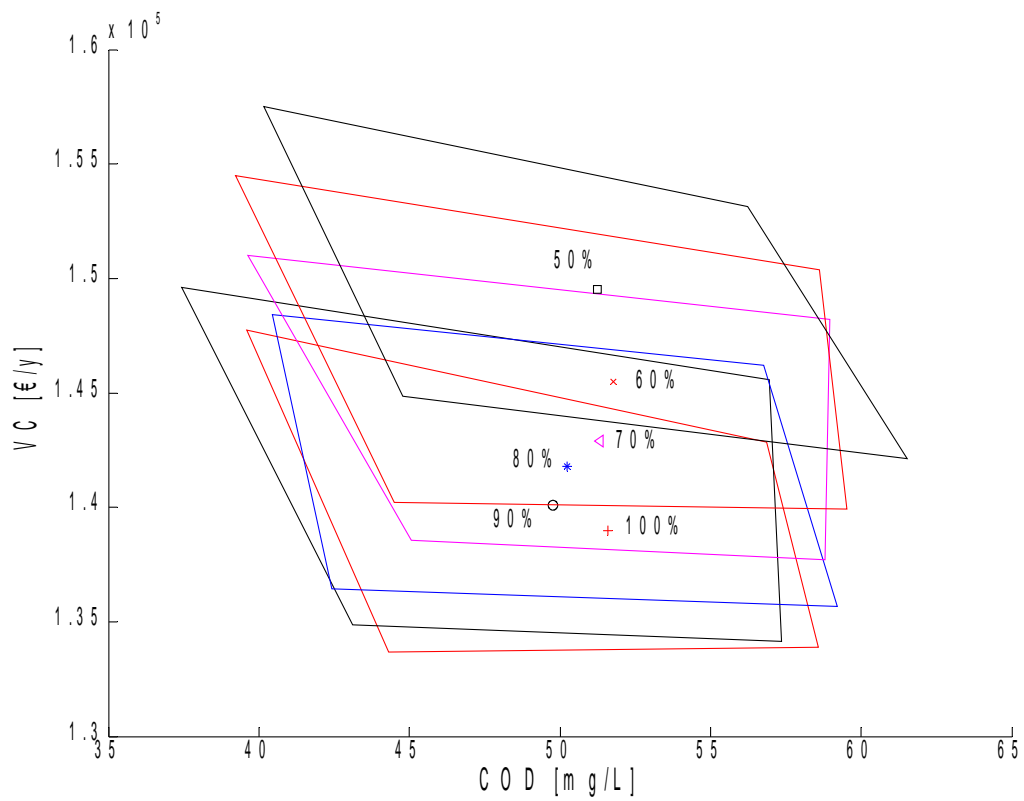

Figure 95: COD and VC for LLAS 30,000PE in Oceanic climate for different volumes (as % of ATV volume).

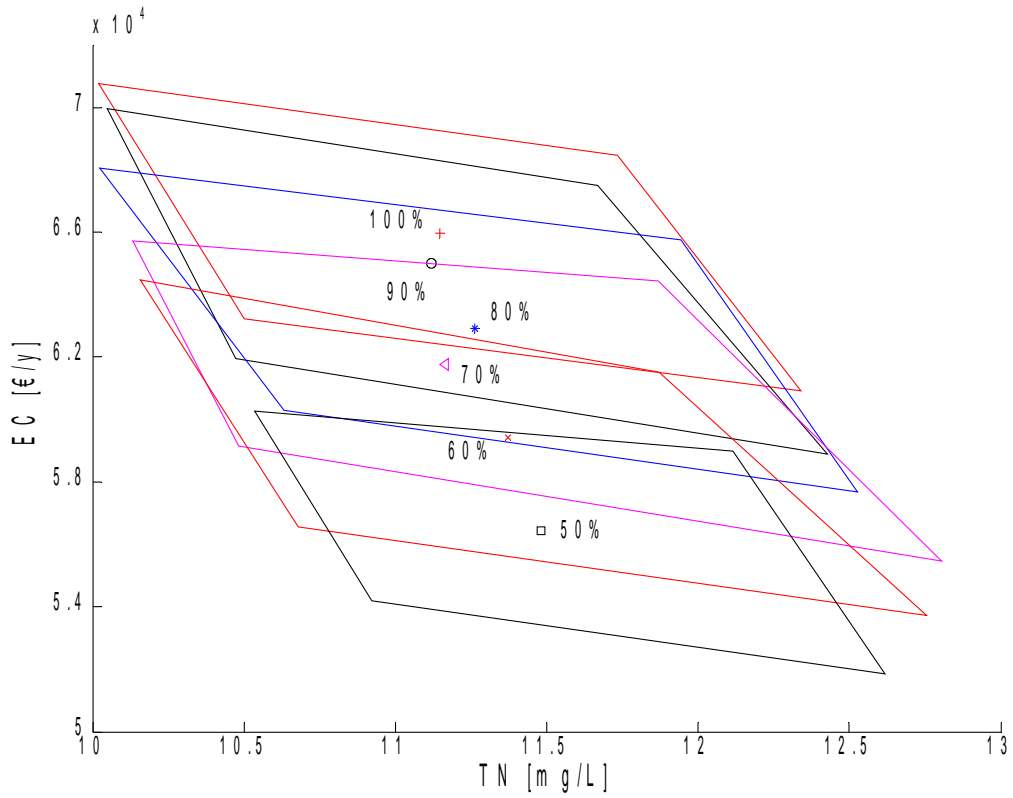

Figure 96: TN and EC for LLAS 30,000PE in Oceanic climate for different volumes (as % of ATV volume).

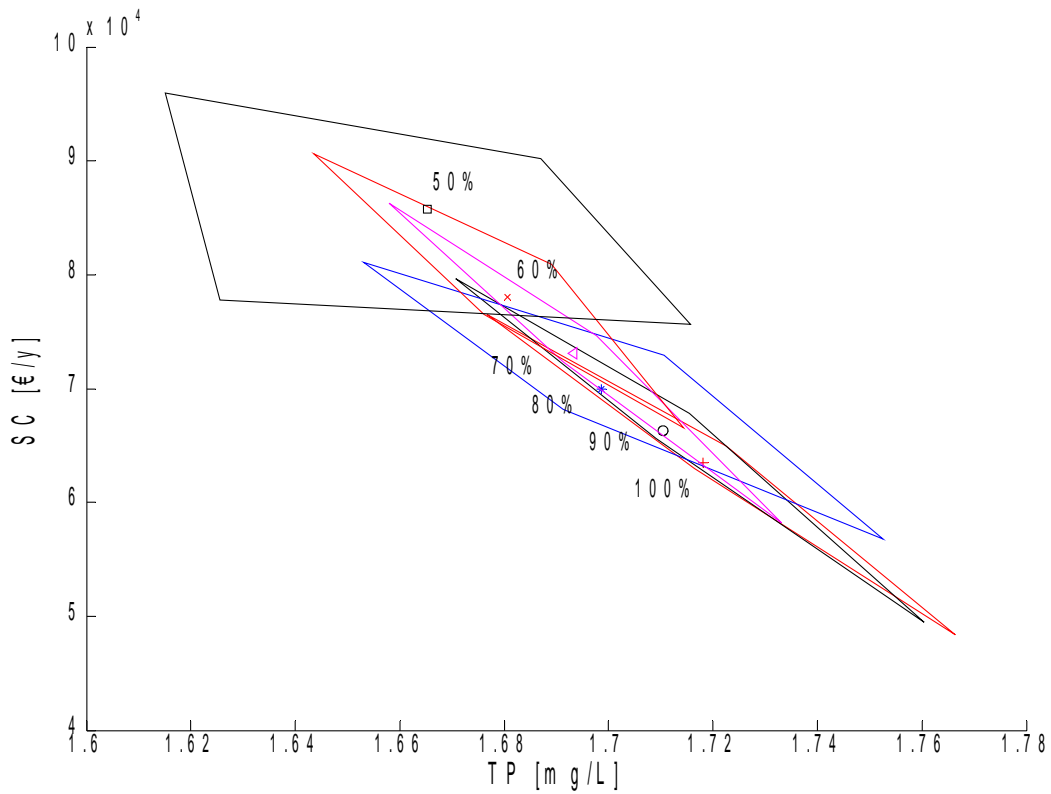

Figure 97: TP and SC for LLAS 30,000PE in Oceanic climate for different volumes (as % of ATV volume).

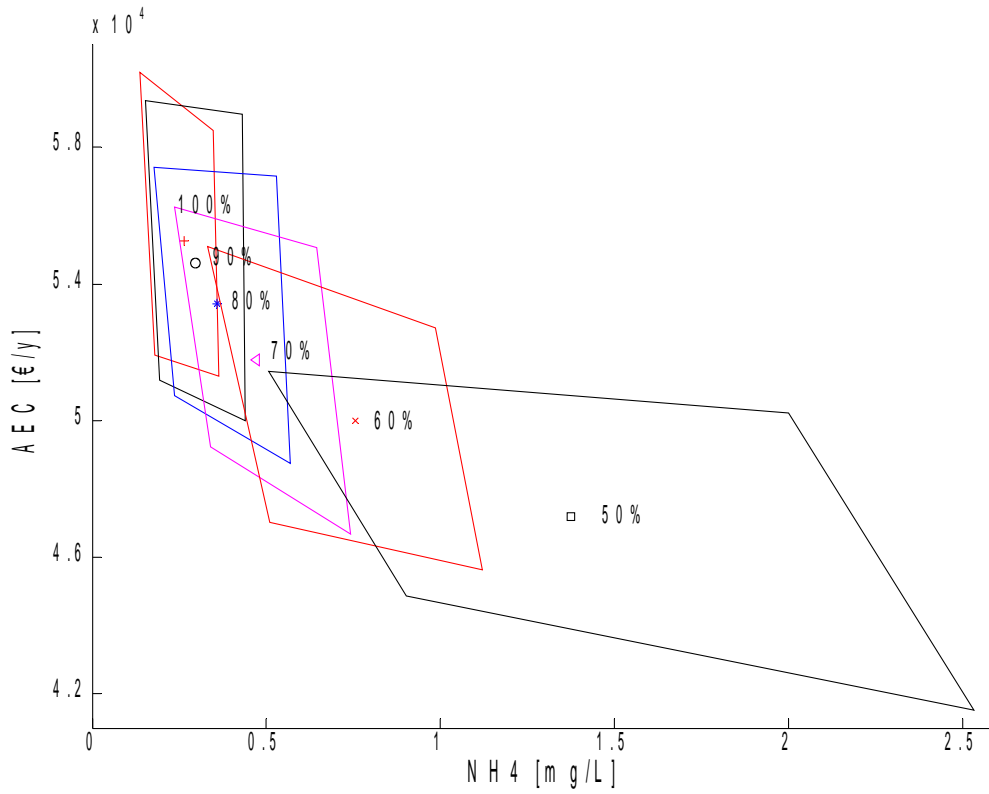

Figure 98: NH<sub>4</sub> and AEC for LLAS 30,000PE in Oceanic climate for different volumes (as % of ATV volume).

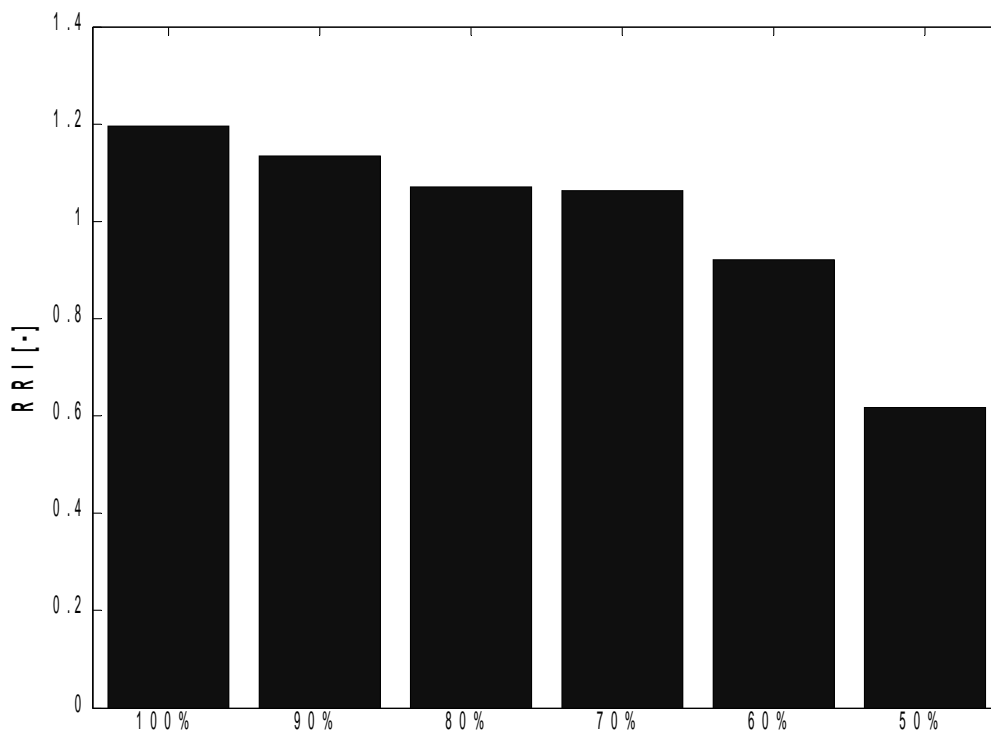

Figure 99: RRI of all variables for LLAS 30,000PE in Oceanic climate for different volumes (as % of ATV volume).

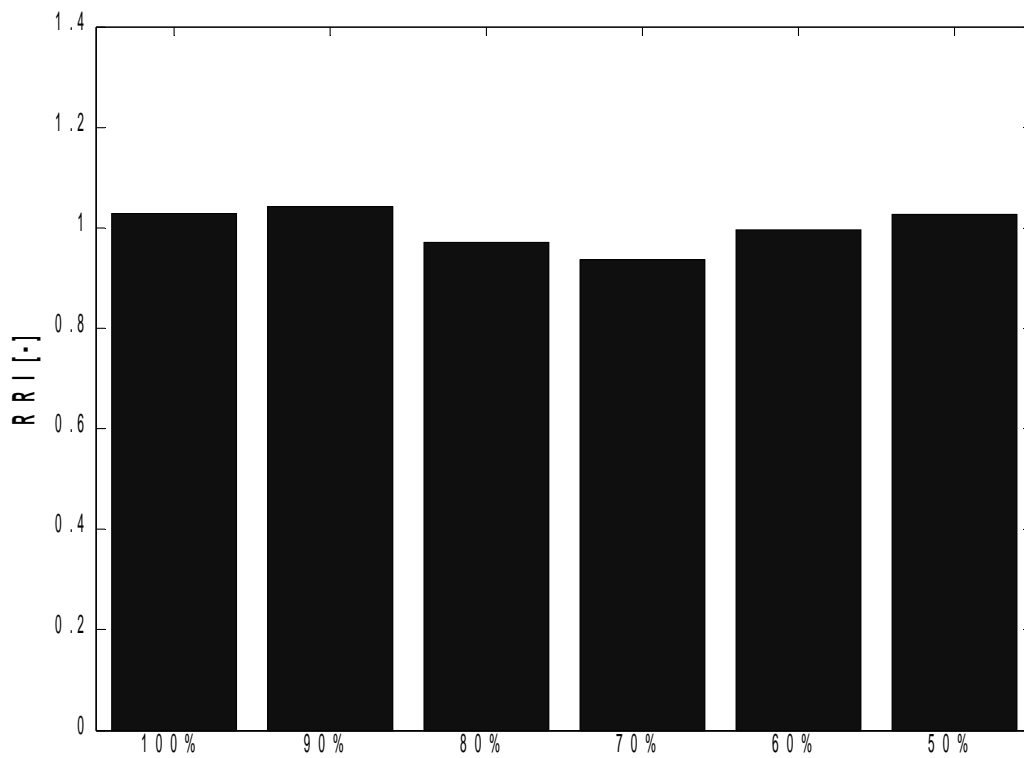

Figure 100: RRI of EQI for LLAS 30,000PE in Oceanic climate for different volumes (as % of ATV volume).

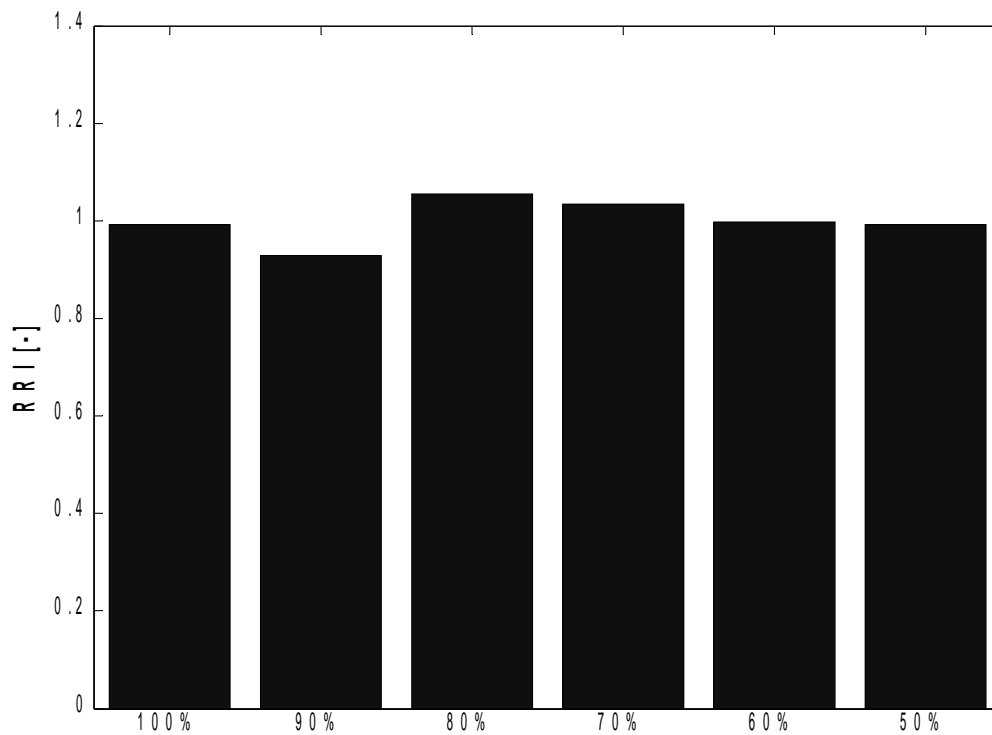

Figure 101: RRI of TC for LLAS 30,000PE in Oceanic climate for different volumes (as % of ATV volume).



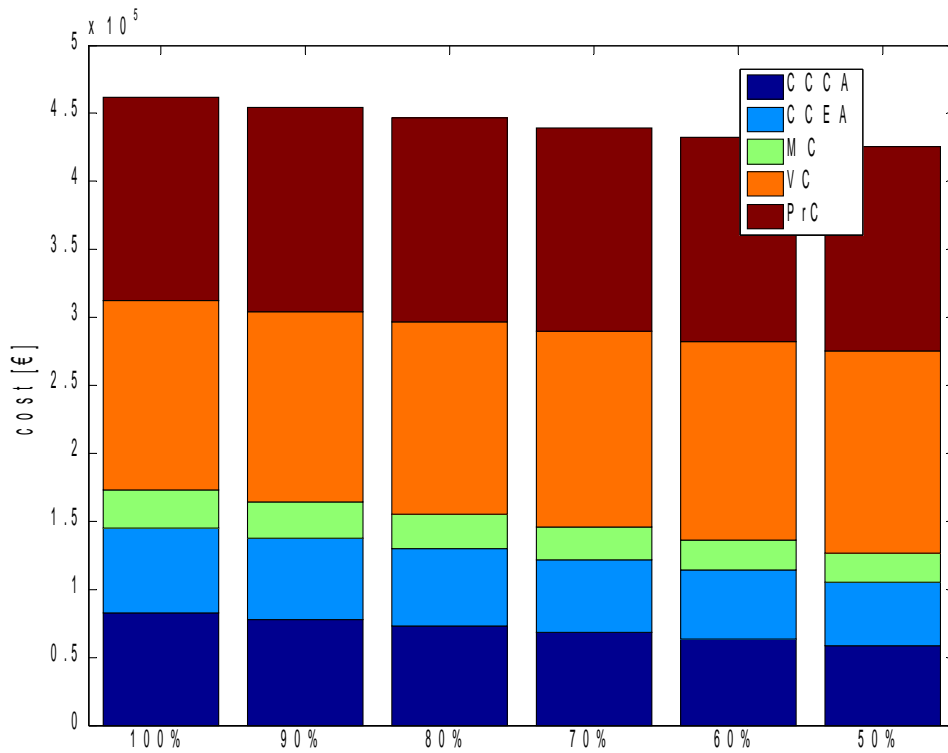

Figure 102: Total costs for LLAS 30,000PE in Oceanic climate for different volumes (as % of ATV volume); CCCA=capital cost for construction annualised, CCEA=capital cost for equipment annualised, MC=maintenance cost, VC=variable cost, PrC=personnel cost.

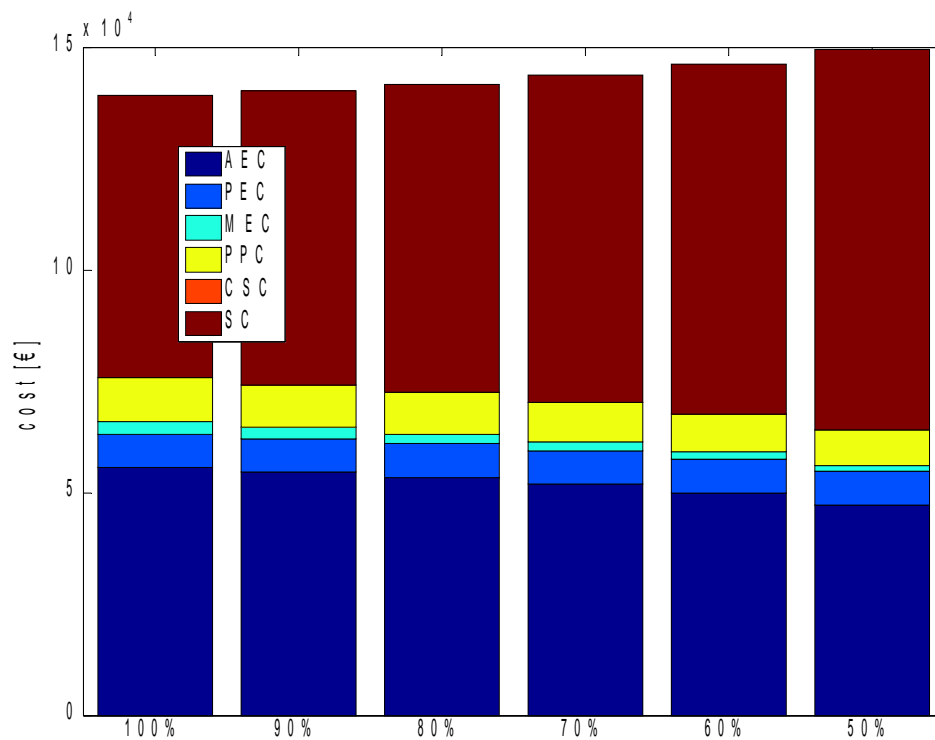

Figure 103: Variable costs for LLAS 30,000PE in Oceanic climate for different volumes (as % of ATV volume); AEC= aeration energy cost, PEC=pumping energy cost, MEC=mixing energy cost, PPC=P-precipitant cost, CSC=C-source cost, SC=sludge cost.

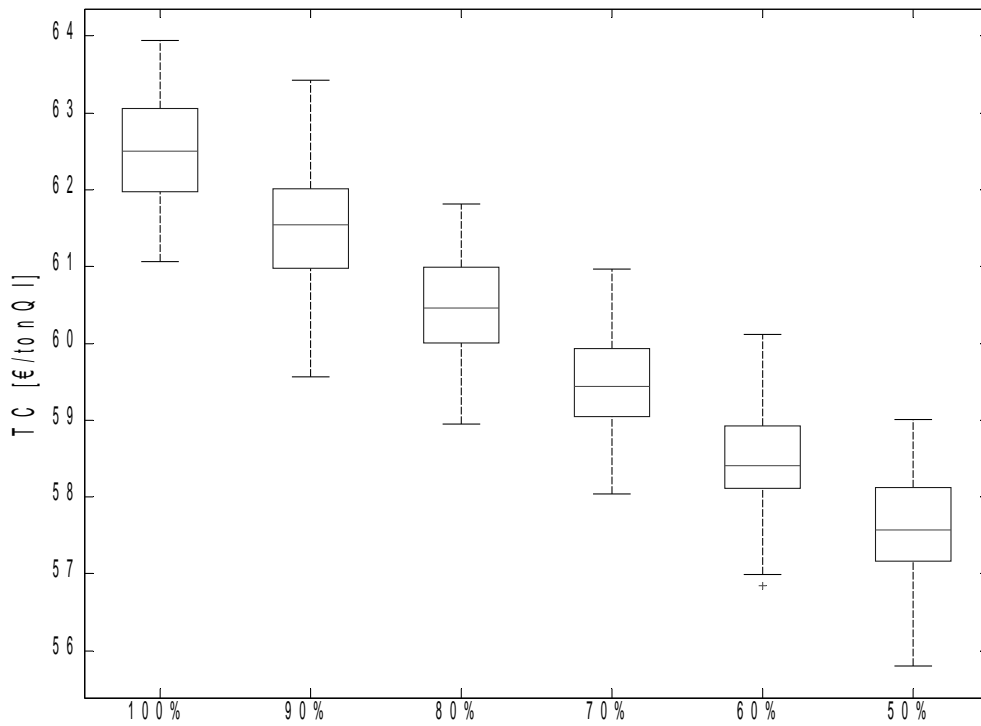

Figure 104: Efficiency of QI removal per TC for LLAS 30,000PE in Oceanic climate for different volumes (as % of ATV volume).

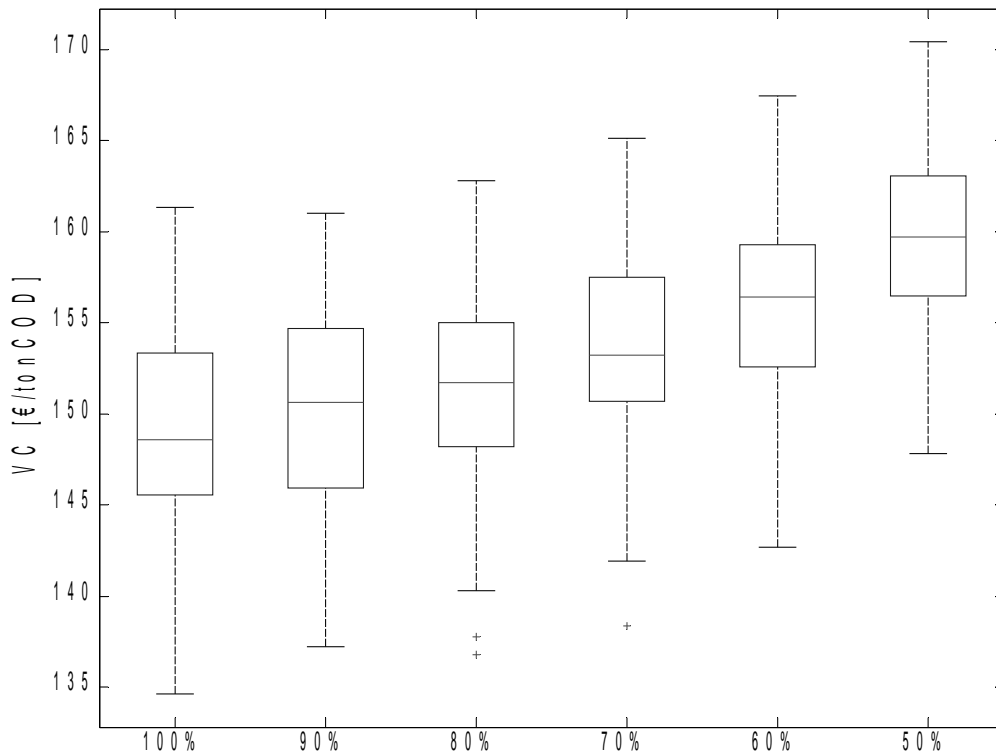

Figure 105: Efficiency of COD removal per VC for LLAS 30,000PE in Oceanic climate for different volumes (as % of ATV volume).

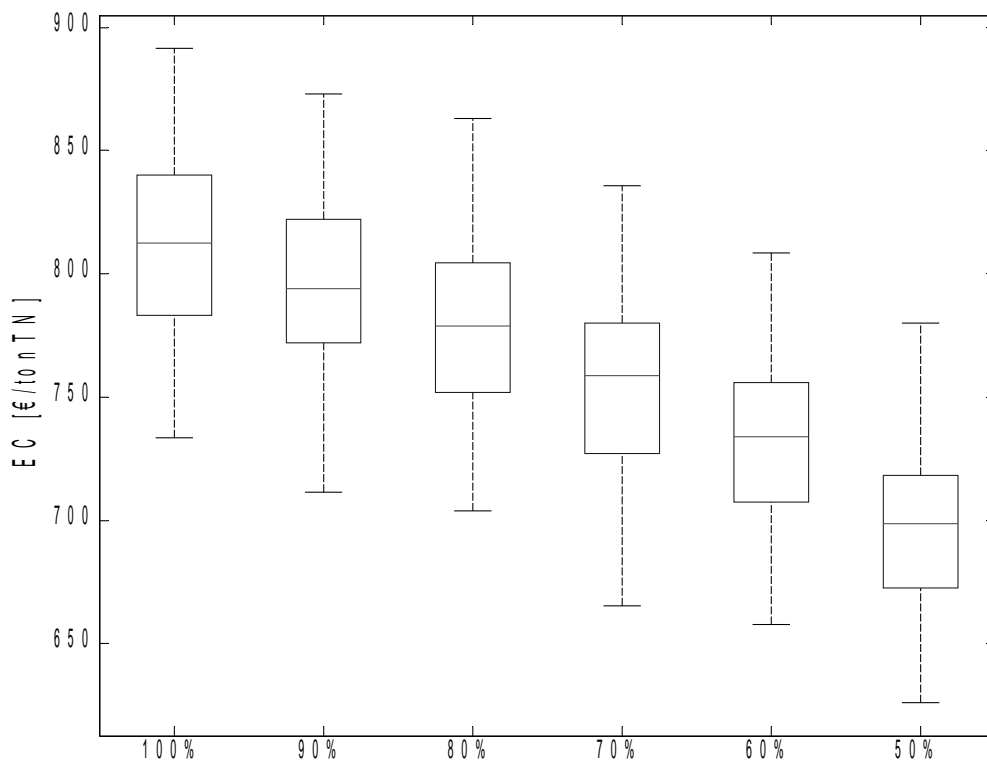

Figure 106: Efficiency of TN removal per EC for LLAS 30,000PE in Oceanic climate for different volumes (as % of ATV volume).

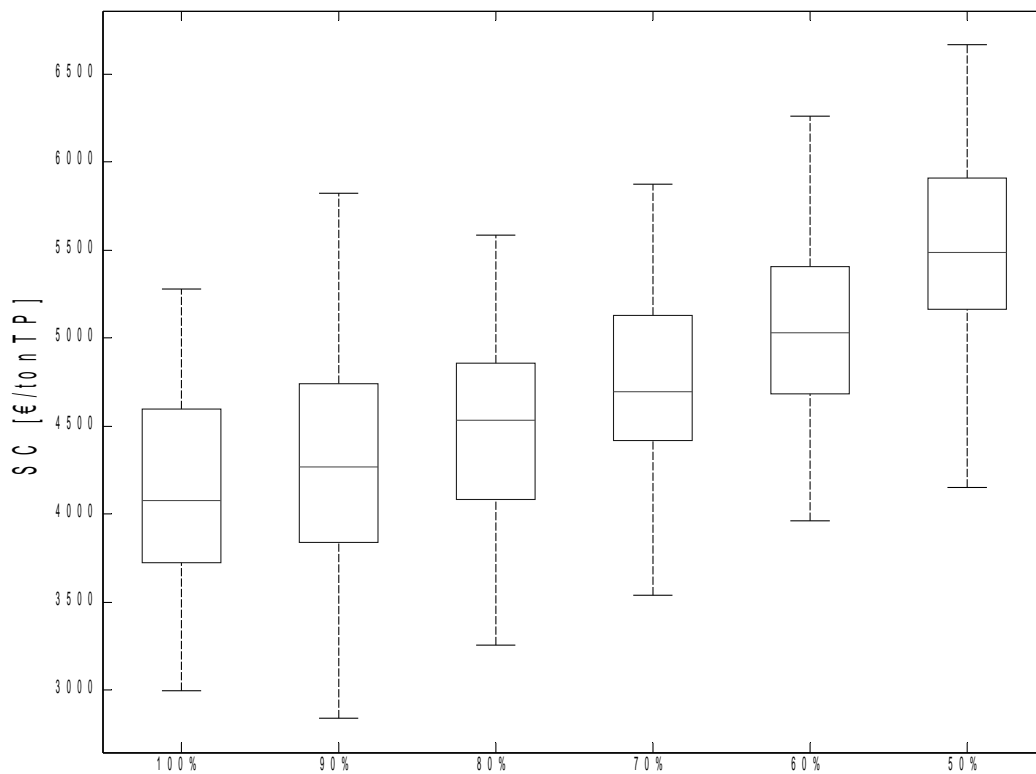

Figure 107: Efficiency of TP removal per SC for LLAS 30,000PE in Oceanic climate for different volumes (as % of ATV volume).

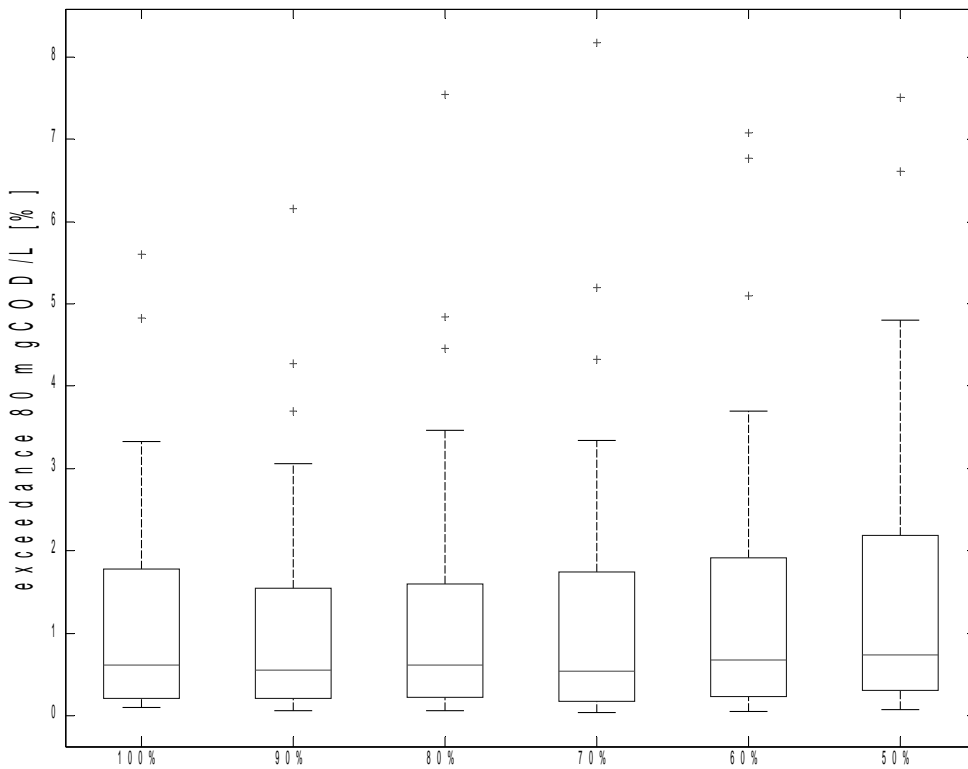

Figure 108: Exceedance time of 80mgCOD/l for LLAS 30,000PE in Oceanic climate for different volumes (as % of ATV volume).

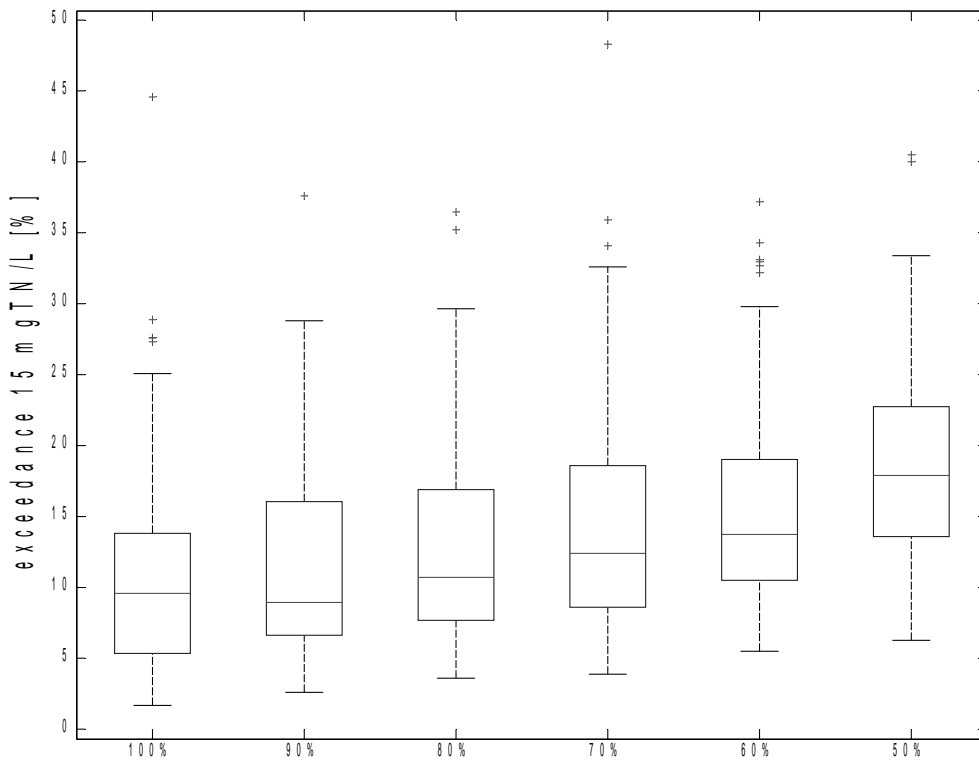

Figure 109: Exceedance time of 15mgTN/l for LLAS 30,000PE in Oceanic climate for different volumes (as % of ATV volume).

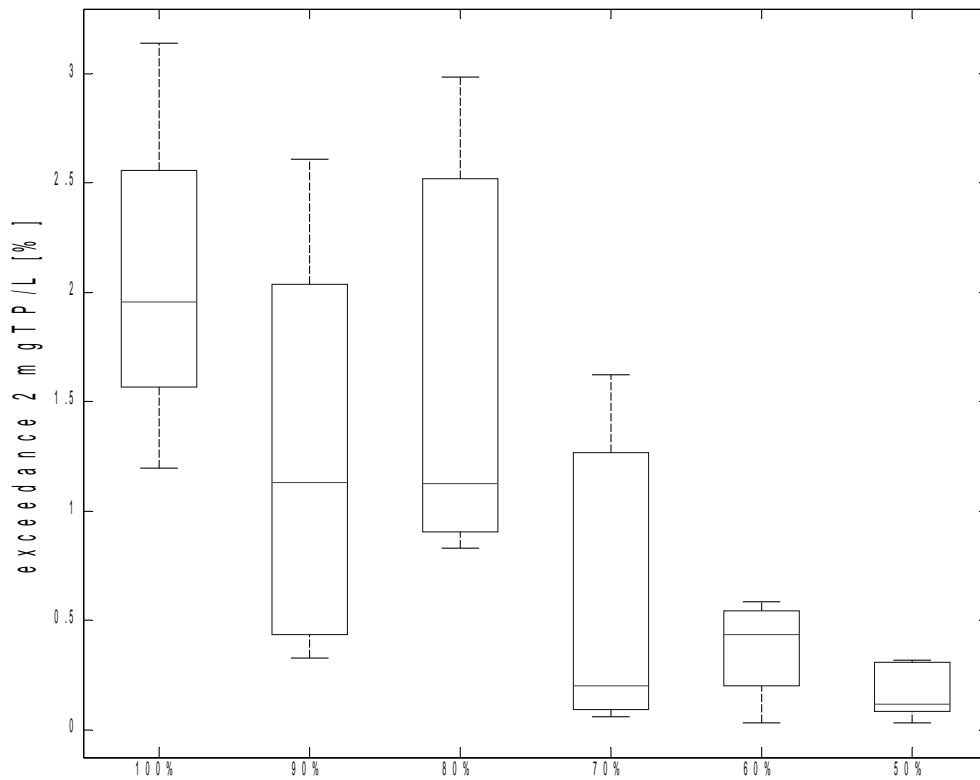

Figure 110: Exceedance time of 2mgTP/l for LLAS 30,000PE in Oceanic climate for different volumes (as % of ATV volume).

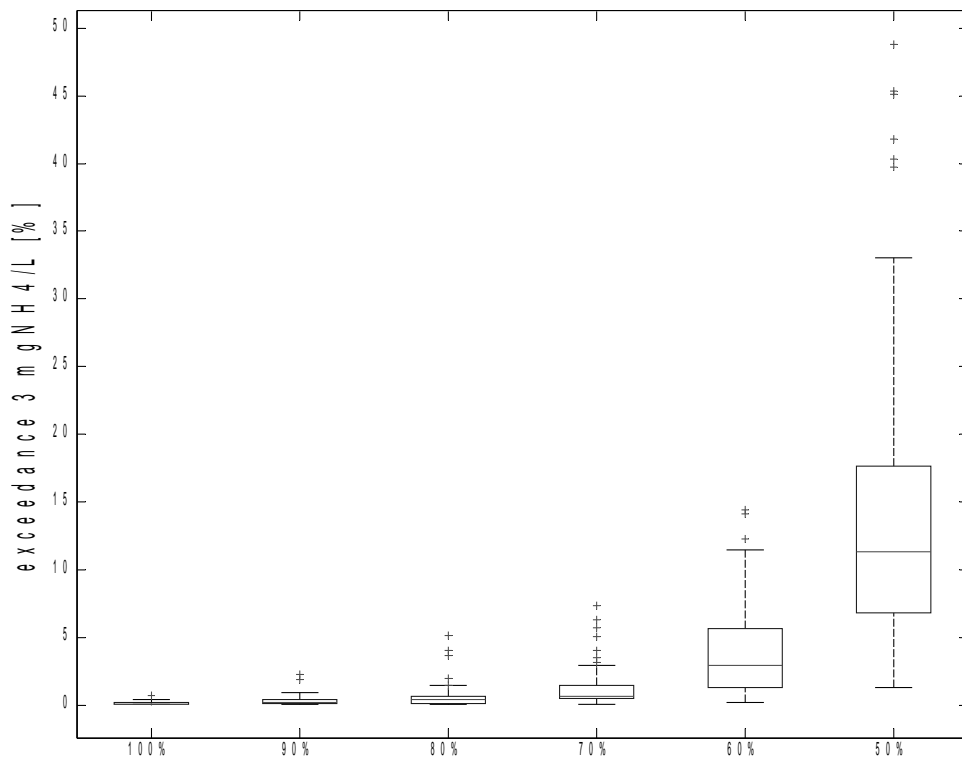

Figure 111: Exceedance time of 3mgNH<sub>4</sub>/l for LLAS 30,000PE in Oceanic climate for different volumes (as % of ATV volume).

## Process comparison

From Figure 112 to Figure 128, the graphs used for the detailed analysis of 30,000PE WWTP size in Oceanic climate are shown. In some figures the configurations Biedenipho, Biedenitro, OD\_bioP and OD\_simP are referred as BDNP, BDN, OD\_b and OD\_s respectively.

## Economic performance

Figure 112 is the most comprehensive performance graph, since it includes information on total costs, on the effluent quality index (see Table 33 for the weights used in the index) and on the uncertainty associated with those two quantities. A Pareto-optimal line appears to be formed by OD\_bioP, A2O, Biedenipho, AO and HLAS, in decreasing order for TC and increasing for EQI. Total costs are low for HLAS since smaller volumes are involved and less aeration energy is required (Figure 116), while sludge costs (Figure 115) are the highest because of the higher production rate of that system. Similar considerations can be made for AO.

A side-effect of the high sludge production of HLAS and AO is the TP removal by sludge wastage, which is the explanation of the lower TP in HLAS than in Biedenitro, which has low sludge production. Biedenitro therefore has low variable costs (Figure 113) due to low sludge cost and moderate aeration cost.

Biedenipho shows the lowest costs among the nutrient removing configurations, with low costs in all categories and good effluent quality in all effluent variables.

LLAS\_PS has the highest TC because of the extra capital costs of the primary settler and for the larger sludge quantity produced. On the other hand it has the best nitrification performance (similar to LLAS, but more reliable) and still has the lowest aeration cost.

Energy costs for OD\_simP (see Figure 114) are higher – in particular in comparison with the similar configuration OD\_bioP – because of the DO set-point slightly higher than the one for OD\_bioP, required to achieve the same nitrification in the two configurations.

All the other configurations have very similar performance concerning EQI and TC.

Looking at the total cost stacks (Figure 117), one can see that personnel, capital and variable costs are on average quite similar, with VC slightly lower. To be noted are the higher capital and variable costs of LLAS\_PS (primary settler and sludge production), the low capital cost of HLAS and AO (low SRT) and the low VC of Biedenipho and Biedenitro (low sludge production).

For the variable cost stacks (Figure 118), it is clear that on an average sludge cost is the major contributor, followed by aeration cost. To be noted are the very high SC and low AEC of HLAS and the very low SC of Biedenipho and Biedenitro.

Figure 119 shows the removal efficiency of the configurations, expressed as the ratio between TC and quality index (QI) removed. It appears that the best efficiency (lowest cost per unit of removed quantity) is found for AO, which combines low costs with more or less good performance for all variables in the EQI. The best nutrient removal configuration is again Biedenipho, while good efficiency is also shown by A2O, OD\_bioP and UCT.

Limiting the analysis on COD removal efficiency per VC (Figure 120), Biedenitro is definitively the best option, followed by Biedenipho. Considering TN removal per EC (Figure 121) again Biedenitro prevails, this time followed by LLAS\_PS. As expected, Biedenipho has the best efficiency of TP removal per SC (Figure 122), while the second best (as median value, but with very large variation) is Biedenitro due to the very low sludge production. AO, LLAS\_PS and HLAS

pay for their high sludge production with low efficiency as shown in Figure 122.

It should be noted that with other assumptions for sludge treatment and disposal the results would have been different, e.g. with anaerobic digestion with energy recovery by bio-gas production, LLAS\_PS (producing primary settling sludge with high bio-gas yield) would perform economically better.

In Figure 123, TC and VC (values averaged for the 10 configurations) are shown relative to the plant PE, for all climates and plant sizes. It appears that TC is highly influenced by the plant size, while VC is influenced only to a lesser extent. Considering that the obtained cost figures do not include all cost items (e.g. land purchase, piping, external services, etc. are missing from the analysis), they are in the range of benchmarking studies performed on actual WWTPs (Balmér, 2000; Bode and Grünebaum, 2000; Lindtner *et al.*, 2004; Stemplewski *et al.*, 2001) and in accordance with the results of the systems analysis (Figure 38), giving confidence in using the proposed methodology to benchmark wastewater systems without the need to perform extensive and detailed data collection on existing systems.

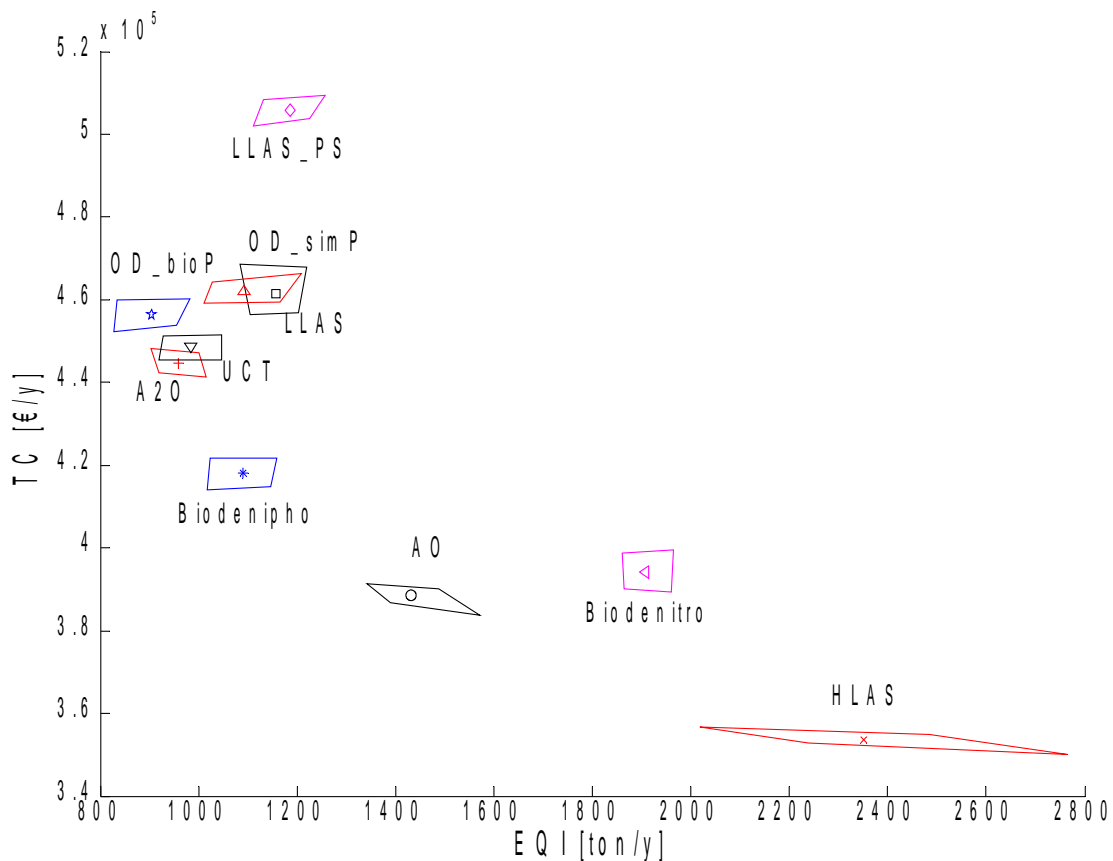

Figure 112: Percentile polygons of EQI and TC for ten 30,000PE configurations in Oceanic climate.

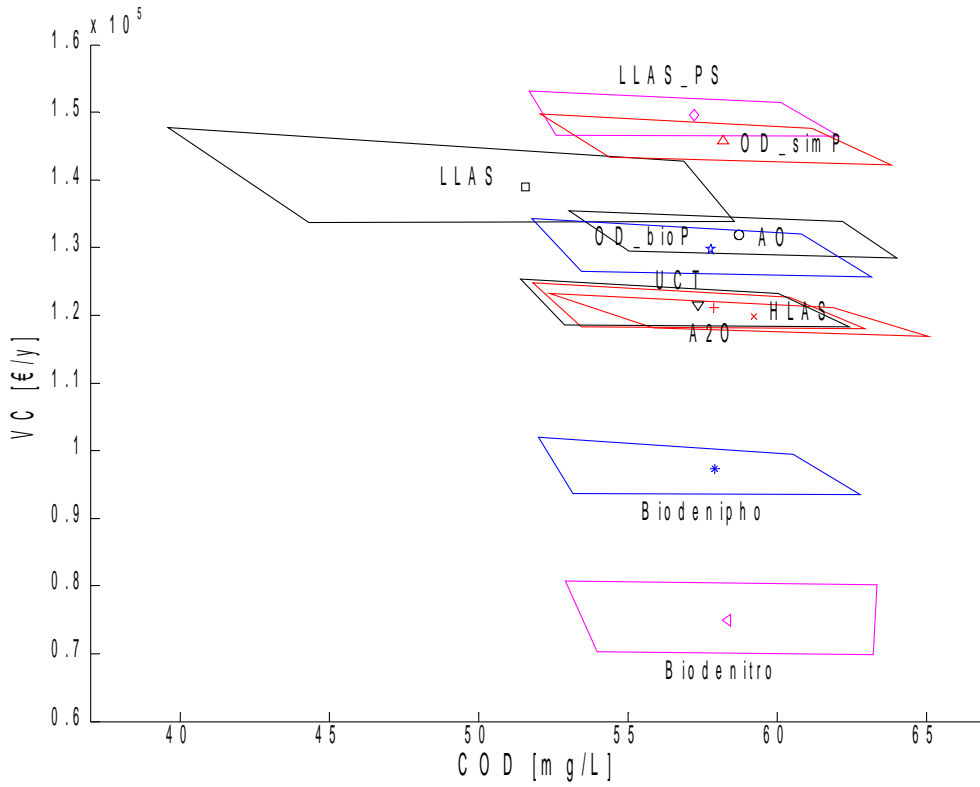

Figure 113: Percentile polygons of COD and VC for ten 30,000PE configurations in Oceanic climate.

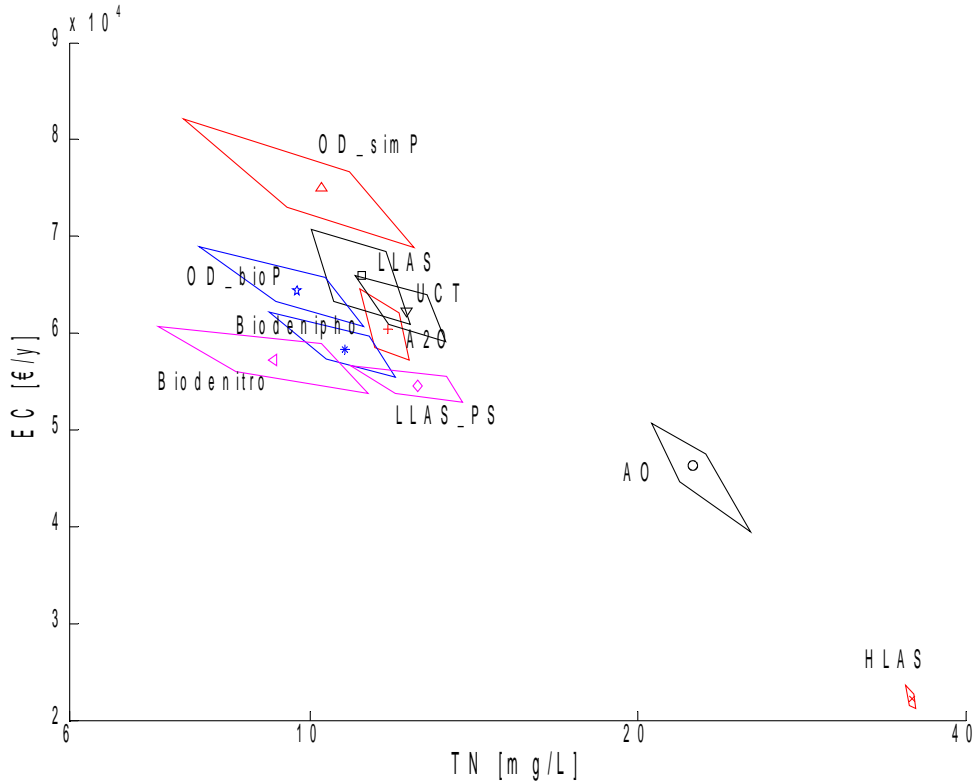

Figure 114: Percentile polygons of TN (log scale) and EC for ten 30,000PE configurations in Oceanic climate.



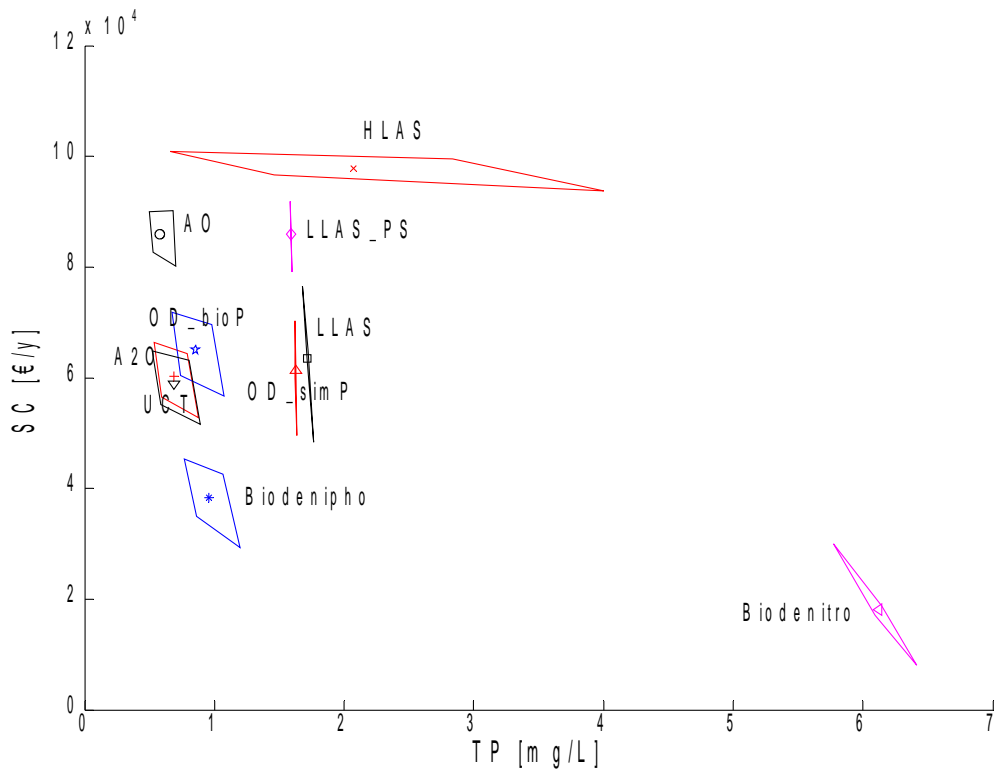

Figure 115: Percentile polygons of TP and SC for ten 30,000PE configurations in Oceanic climate.

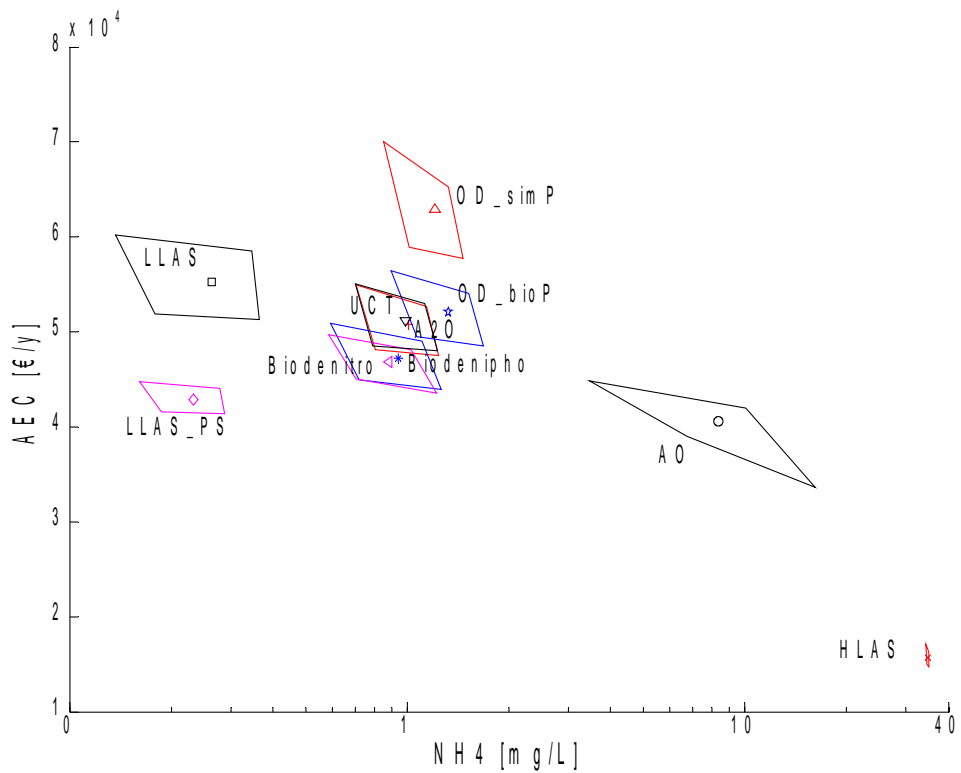

Figure 116: Percentile polygons of NH<sub>4</sub> (log scale) and AEC for ten 30,000PE configurations in Oceanic climate.

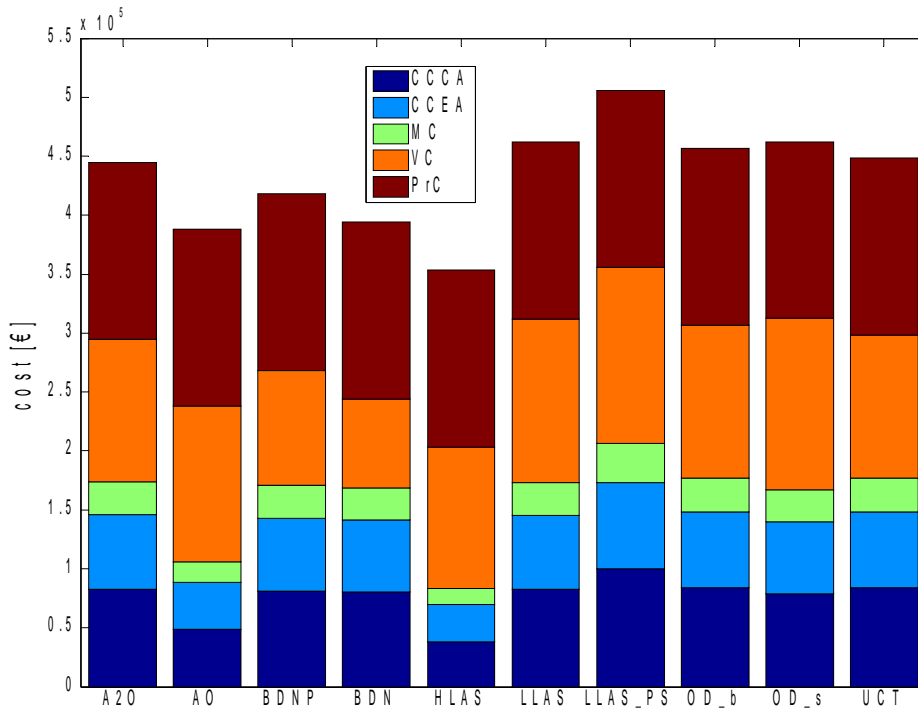

Figure 117: Total costs for ten 30,000PE configurations in Oceanic climate; CCCA=capital cost for construction annualised, CCEA=capital cost for equipment annualised, MC=maintenance cost, VC=variable cost, PrC=personnel cost.

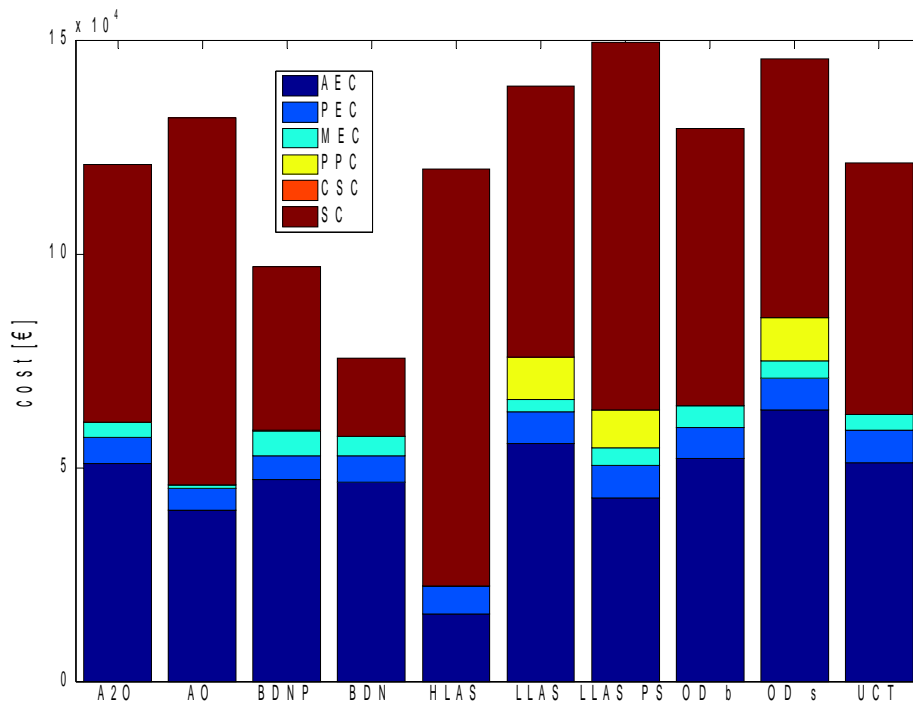

Figure 118: Variable costs for ten 30,000PE configurations in Oceanic climate; AEC= aeration energy cost, PEC=pumping energy cost, MEC=mixing energy cost, PPC=P-precipitant cost, CSC=C-source cost, SC=sludge cost.

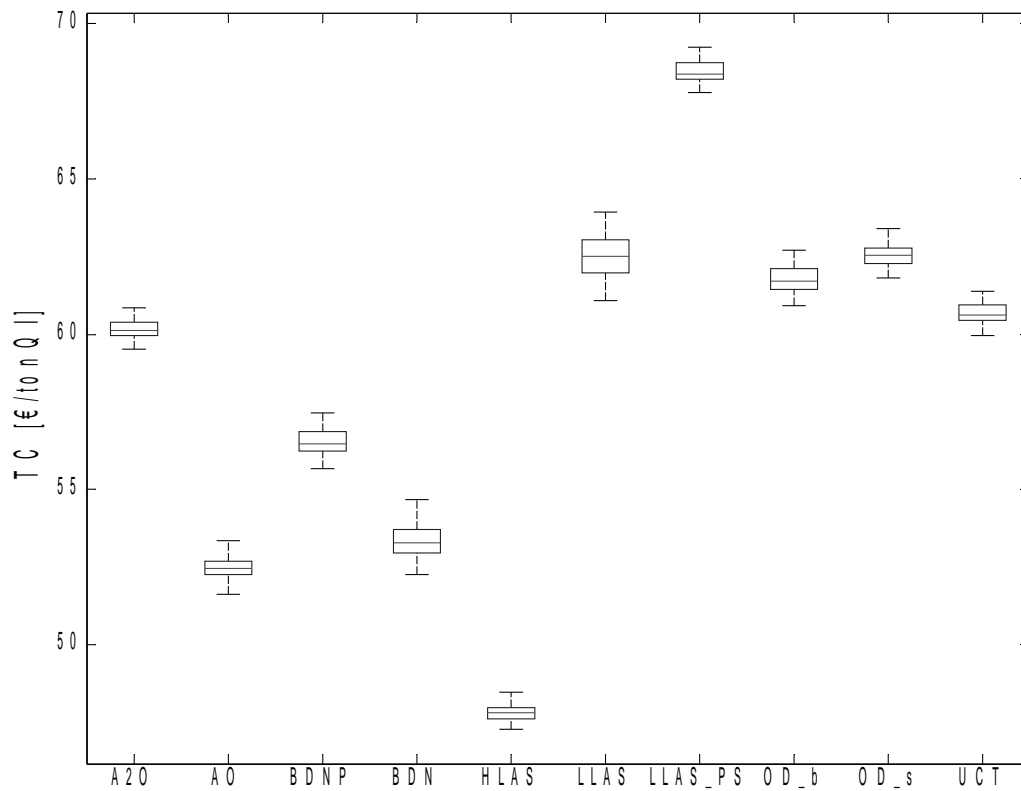

Figure 119: Efficiency of QI removal per TC for ten 30,000PE configurations in Oceanic climate.

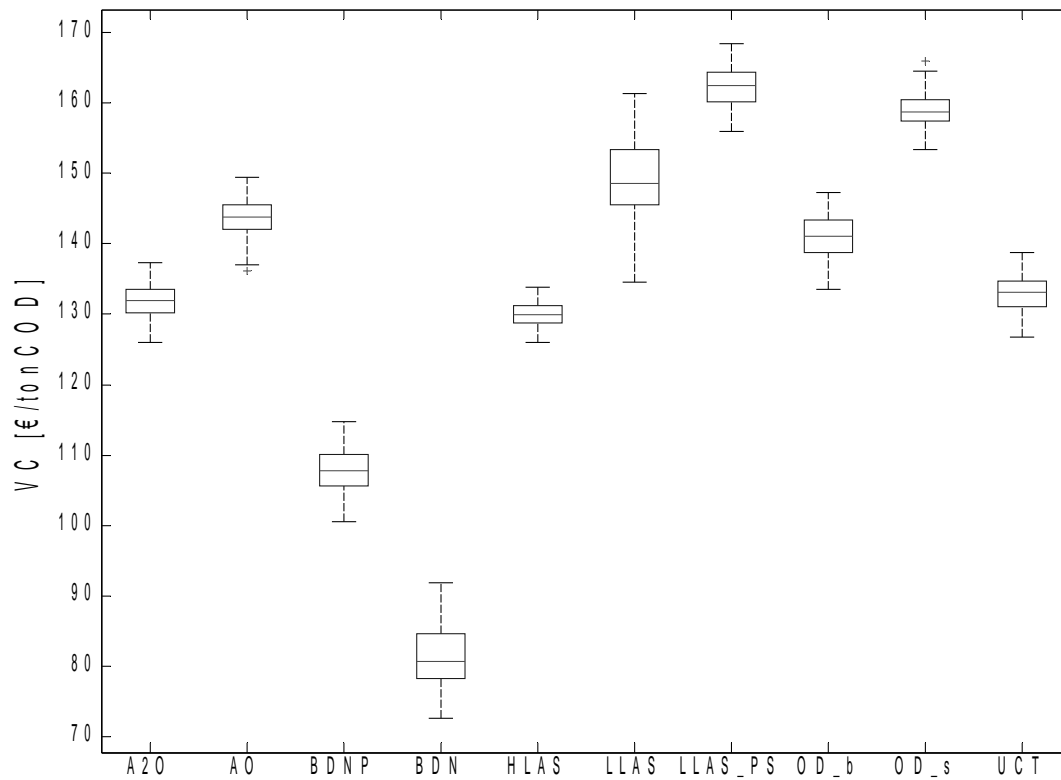

Figure 120: Efficiency of COD removal per VC for ten 30,000PE configurations in Oceanic climate.

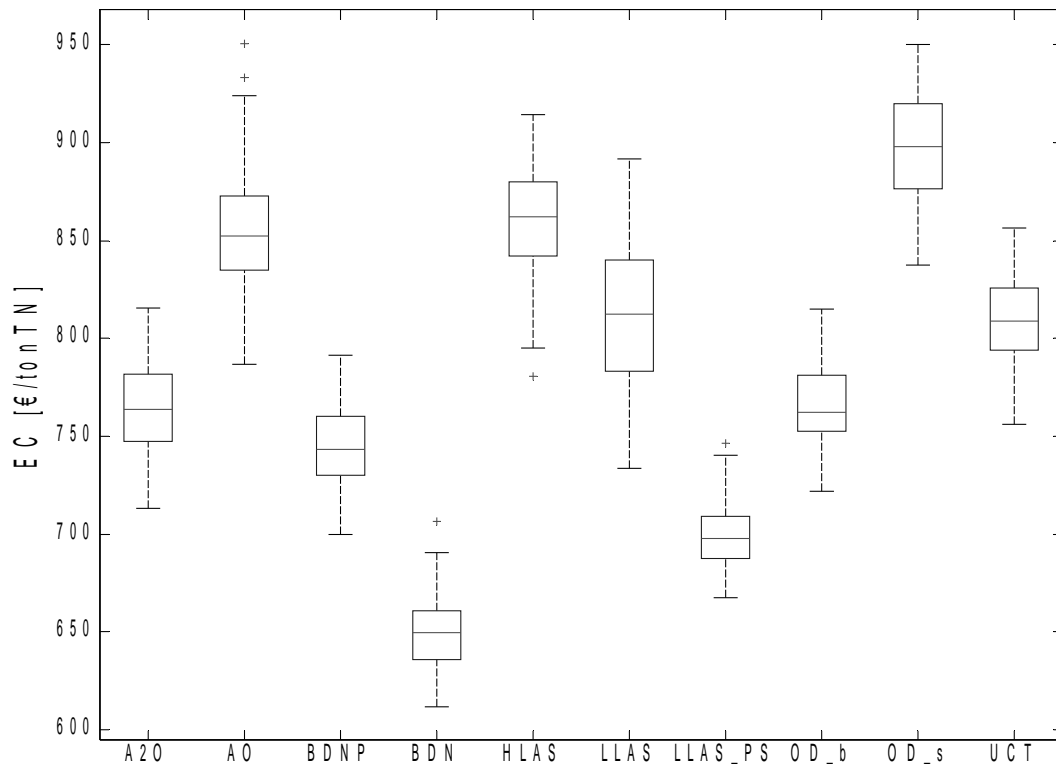

Figure 121: Efficiency of TN removal per EC for ten 30,000PE configurations in Oceanic climate.

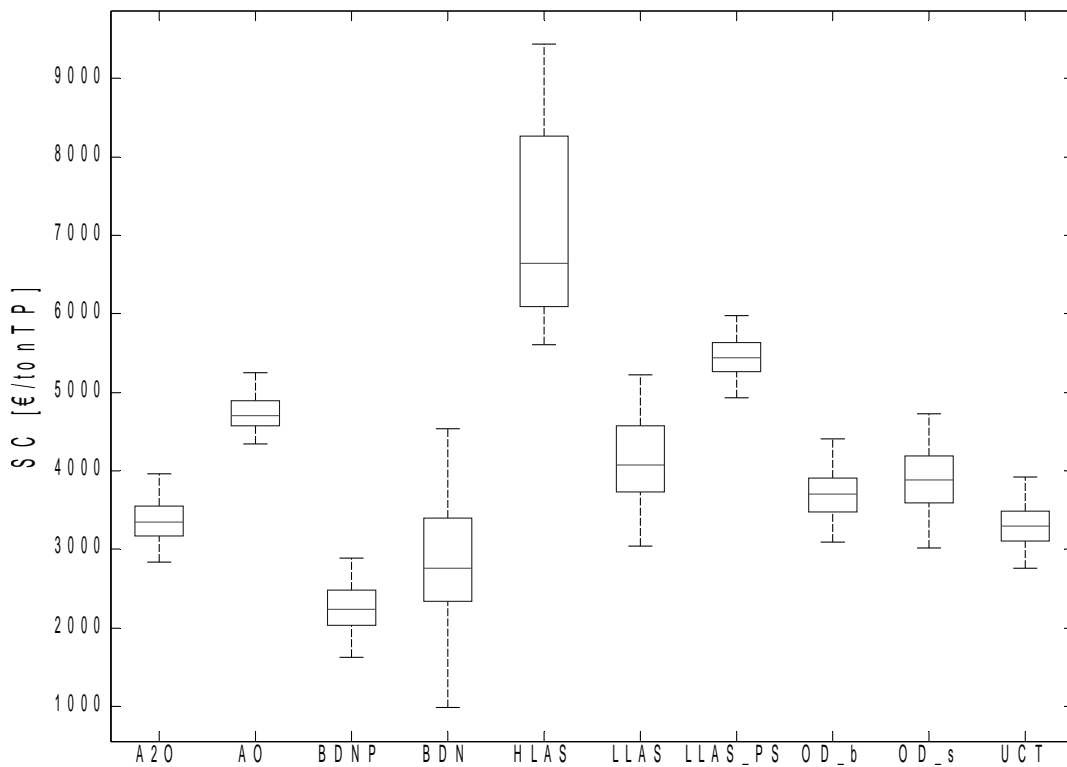

Figure 122: Efficiency of TP removal per SC for ten 30,000PE configurations in Oceanic climate.

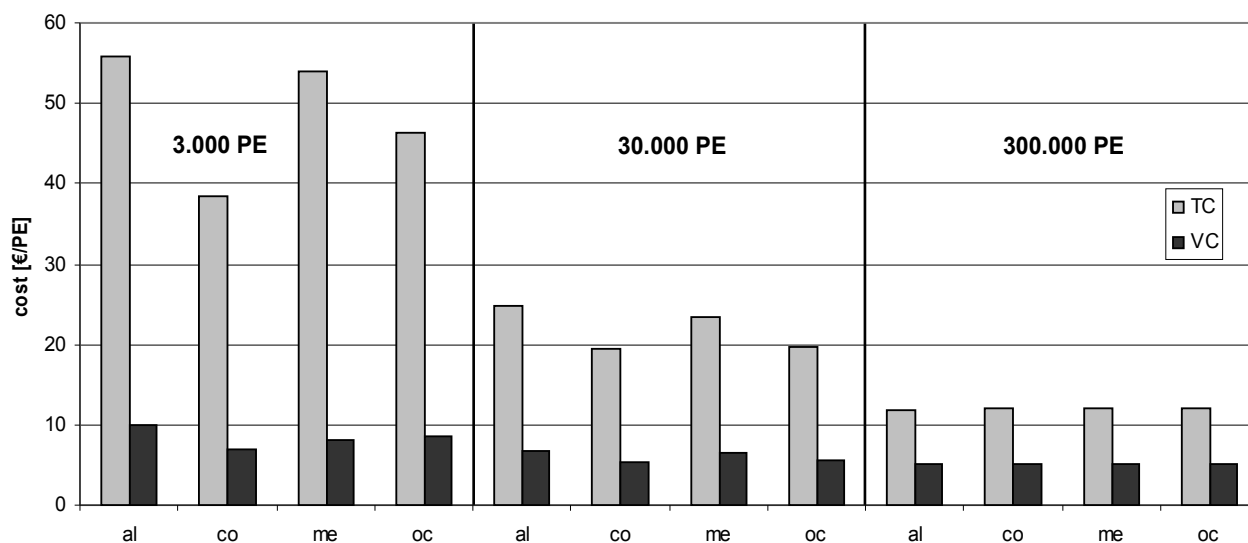

Figure 123: TC and VC per PE for different plant sizes and climates; al=Alpine, co=Continental, me=Mediterranean, oc=Oceanic.

### Environmental performance

The bad EQI for HLAS (Figure 112) is due to the high  $\text{NH}_4$  and TN effluent (Figure 114 and Figure 116) and to the rather high TP effluent (Figure 115) which also causes the large variation in EQI. This can also be seen in Figure 124, where the single contributions to the EQI are put in evidence.

As for COD (Figure 113) all configurations have very good and similar performance, never approaching the regulatory limit of 125mgCOD/l (CEC, 1991), due to the generous dimensioning of the adopted ATV guidelines.

Biodenitro has the lowest TN effluent for its good denitrification performance (Figure 116).

The TP removal of LLAS, LLAS\_PS and OD\_simP is extremely reliable (small polygon along the TP axis) since they are equipped with chemical removal by controlled dosage of P-precipitant.

The TP effluent of AO is the best amongst all configurations thanks to its excellent bio-P removal that does not suffer from disturbances through  $\text{NO}_3$  recirculation. Some nitrification takes place and the combination of lower TN and TP effluent leads to a better EQI than the one of HLAS.

The exceedance of certain thresholds has also been investigated. For COD (Figure 125) the value of 80mgCOD/l has been chosen since the regulatory limit (CEC, 1991) of 125mgCOD/l was never reached by any configuration. The best performing configuration is LLAS\_PS, for which one can be 50% sure that the threshold is exceeded for less than 1% of the year, while the least performing are the high rate systems AO and HLAS for which the exceedance is between 2% and 4% of the year.

With the threshold of 15mgTN/l (yearly average requirement for 30,000PE; CEC, 1991), Biodenitro and OD\_bioP seems to be the most stable (as shown in Figure 126, there is 50% certainty that the value is exceeded only 5% of the year), while of course HLAS and AO have very poor performance (90%-100% exceedance). LLAS is able to reach a lower TN effluent thanks to its better denitrification, that is due to the absence of the COD-removing primary settler.

For 2mgTP/l (yearly average requirement for 30,000PE; CEC, 1991), Biedenitro does not appear in the graph because it always has a higher effluent TP concentration (as shown in Figure 127, there is 100% certainty to always exceed the threshold), while LLAS\_PS and OD\_simP are also not shown since they always have an effluent TP concentration below the limit (100% sure to be always below the threshold). HLAS has the largest TP effluent variability.

Considering the arbitrary limit of 3mgNH<sub>4</sub>/l, one can be 100% sure to be always above the threshold with HLAS and AO also has a very probable value exceedance (Figure 128). The most reliable configurations are LLAS and LLAS\_PS, for which one can be 95% sure that the threshold is exceeded only 0.6% and 0.1% of the year respectively.

**Reliability analysis**

Concerning the reliability of the different configurations, the highest RRI calculated for all variables together (Figure 129) is attributed to LLAS\_PS, which means that the addition of a primary clarifier significantly increases the stability of the process. The lowest values are found for the biological nutrient removal systems, probably due to the inherently higher instability of biological processes. Slightly higher reliability is found for Biedenipho, which suggests a positive influence of alternating cycles.

The RRI calculated for the EQI (Figure 130) does not show much variations, except for LLAS\_PS, which is clearly more stable in its environmental performance and for HLAS, which suffers from its high TP removal performance variability.

The RRI of TC (Figure 131) shows again higher stability for LLAS\_PS and slightly lower RRI for LLAS and Biedenitro, due to their higher variations in all variable cost categories.

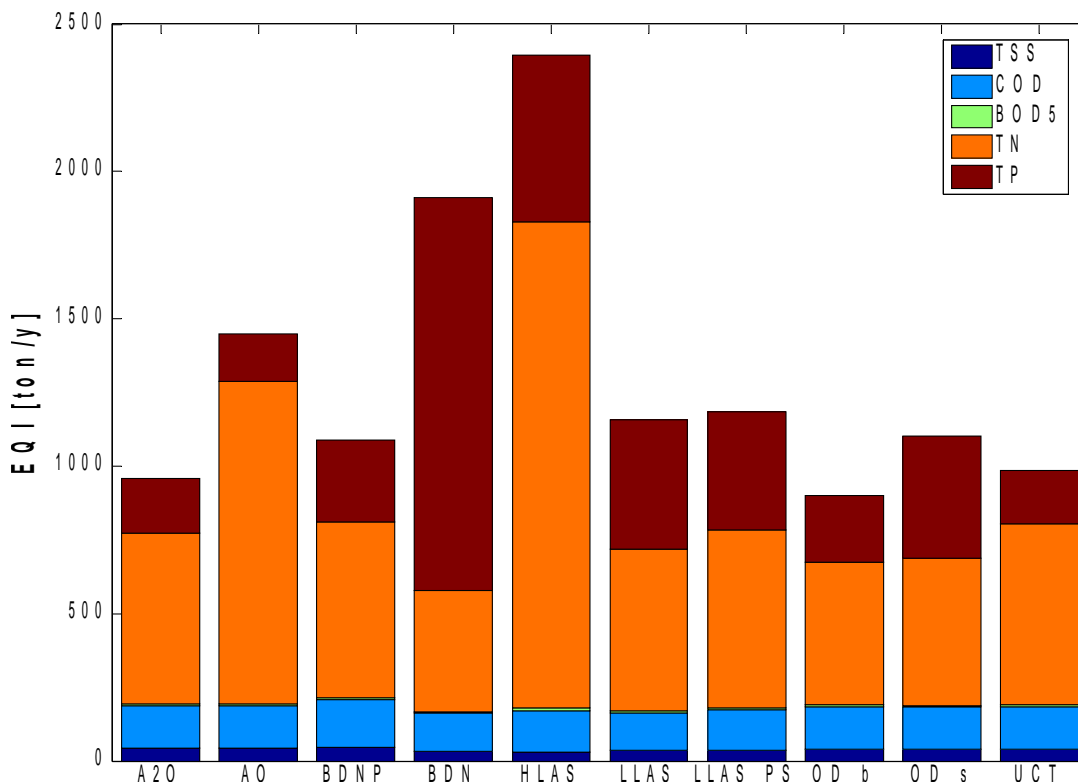

Figure 124: Contributions to EQI for ten 30,000PE configurations in Oceanic climate.

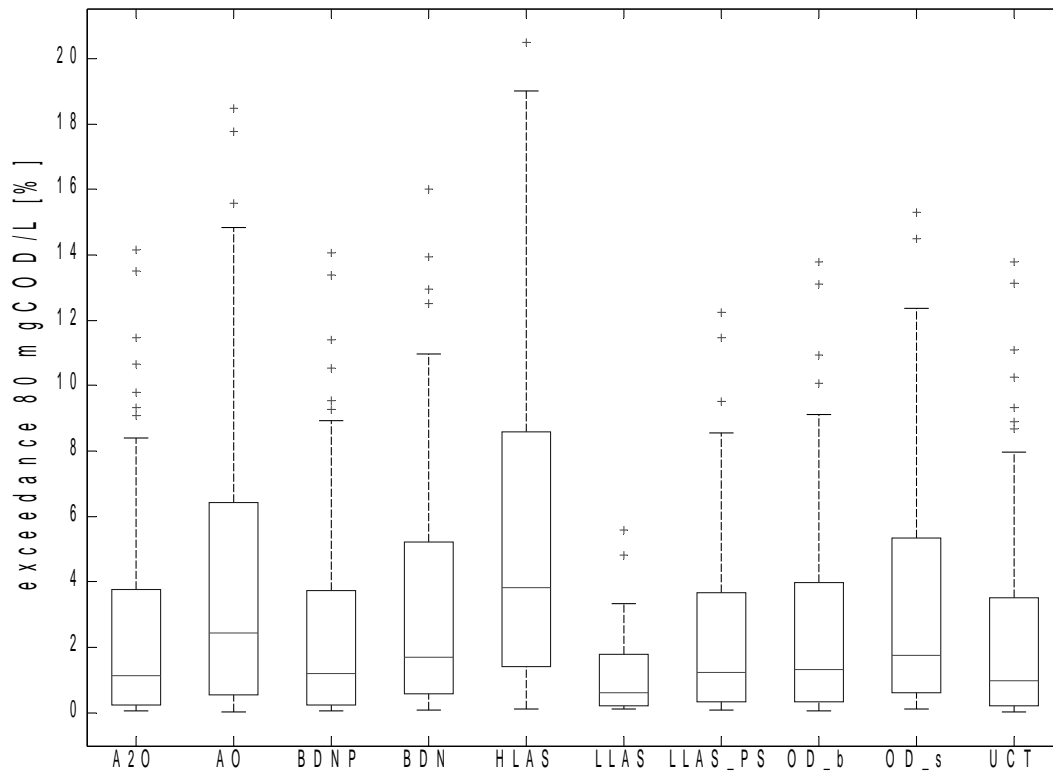

Figure 125: Exceedance time of 80mgCOD/l for ten 30,000PE configurations in Oceanic climate.

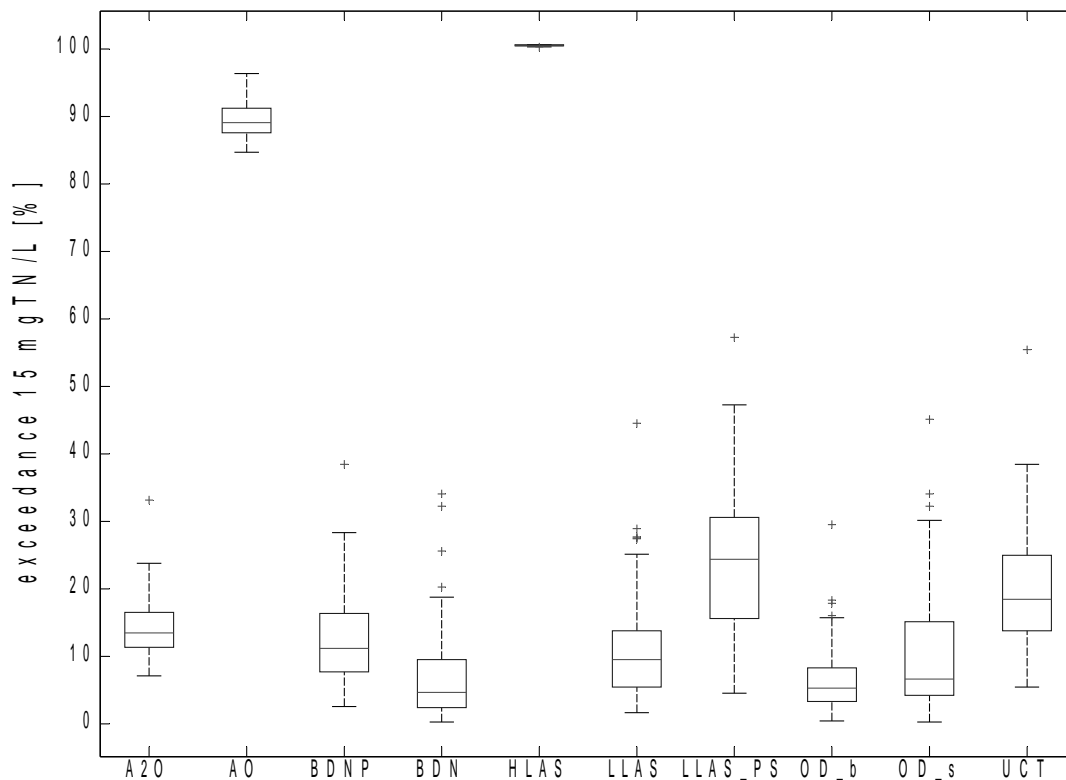

Figure 126: Exceedance time of 15mgTN/l for ten 30,000PE configurations in Oceanic climate.

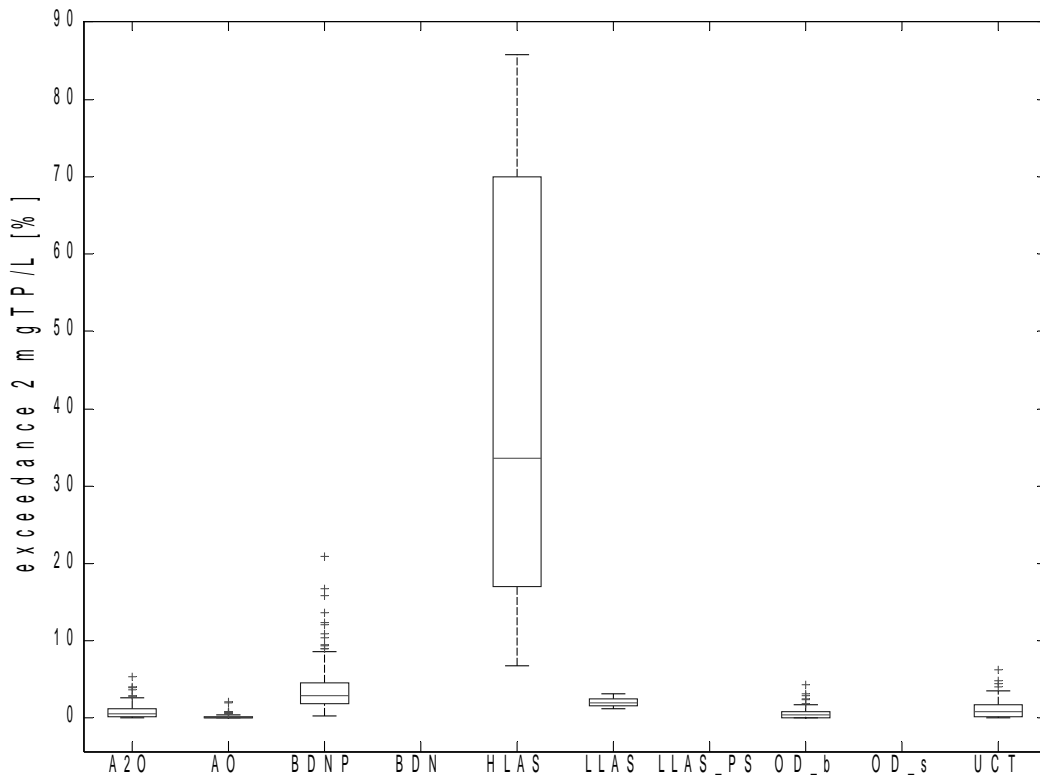

Figure 127: Exceedance time of 2mgTP/l for ten 30,000PE configurations in Oceanic climate.

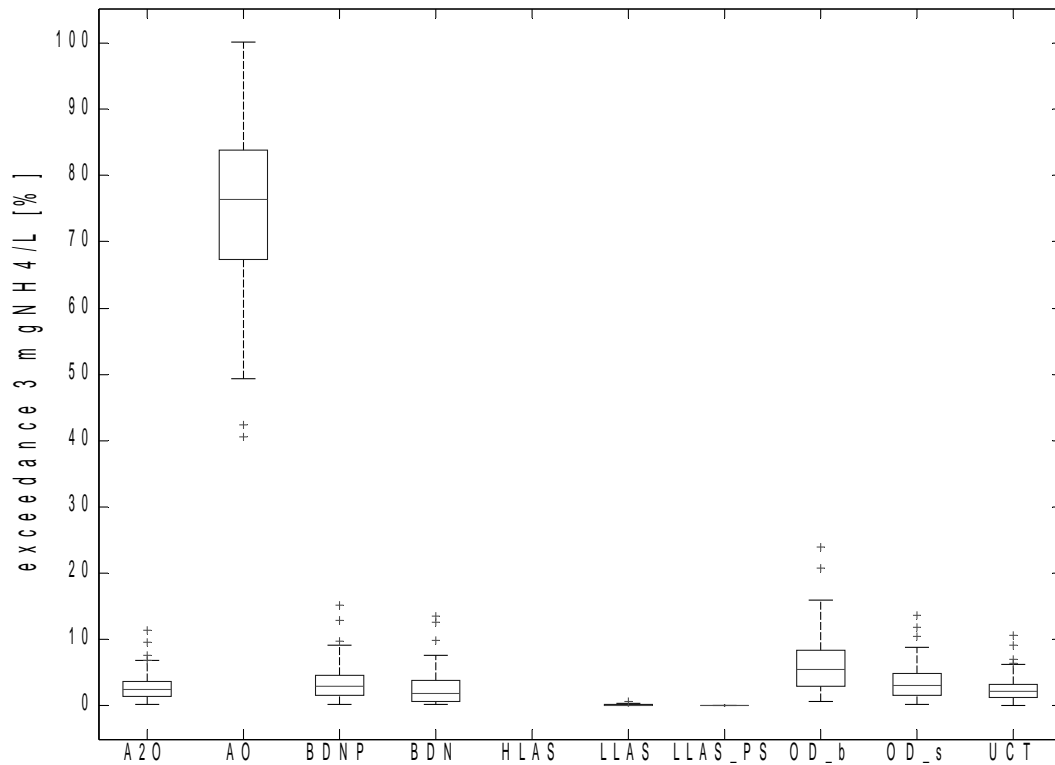

Figure 128: Exceedance time of 3mgNH4/l for ten 30,000PE configurations in Oceanic climate.



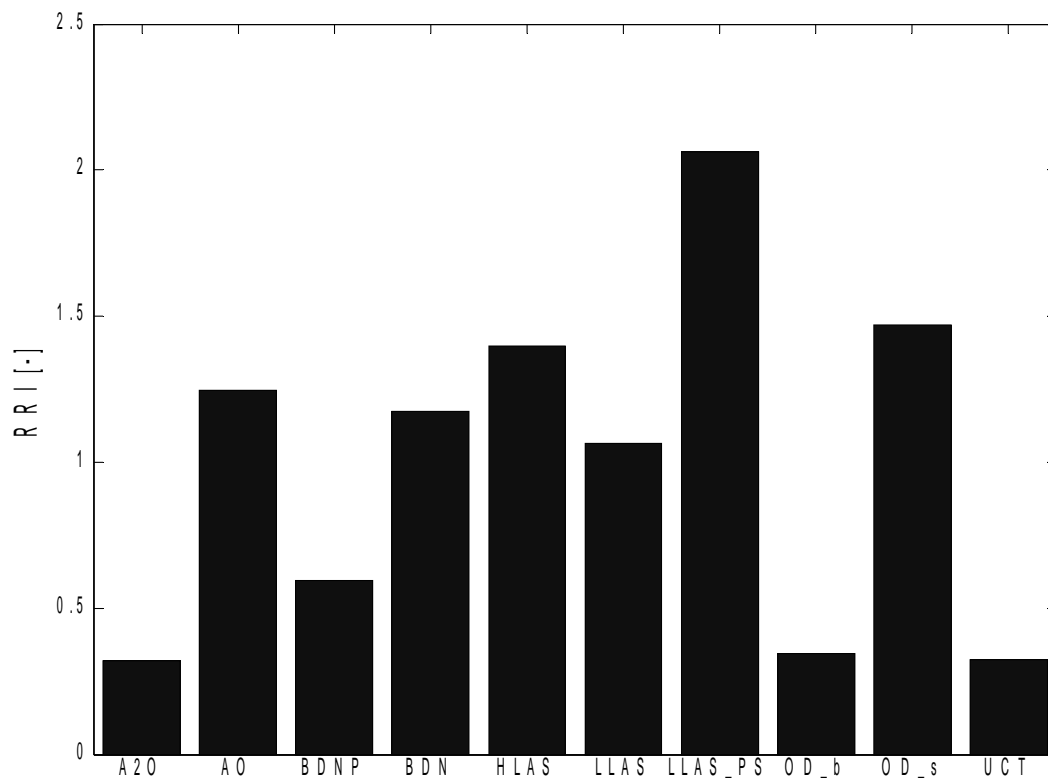

Figure 129: RRI of all variables for ten 30,000PE configurations in Oceanic climate.

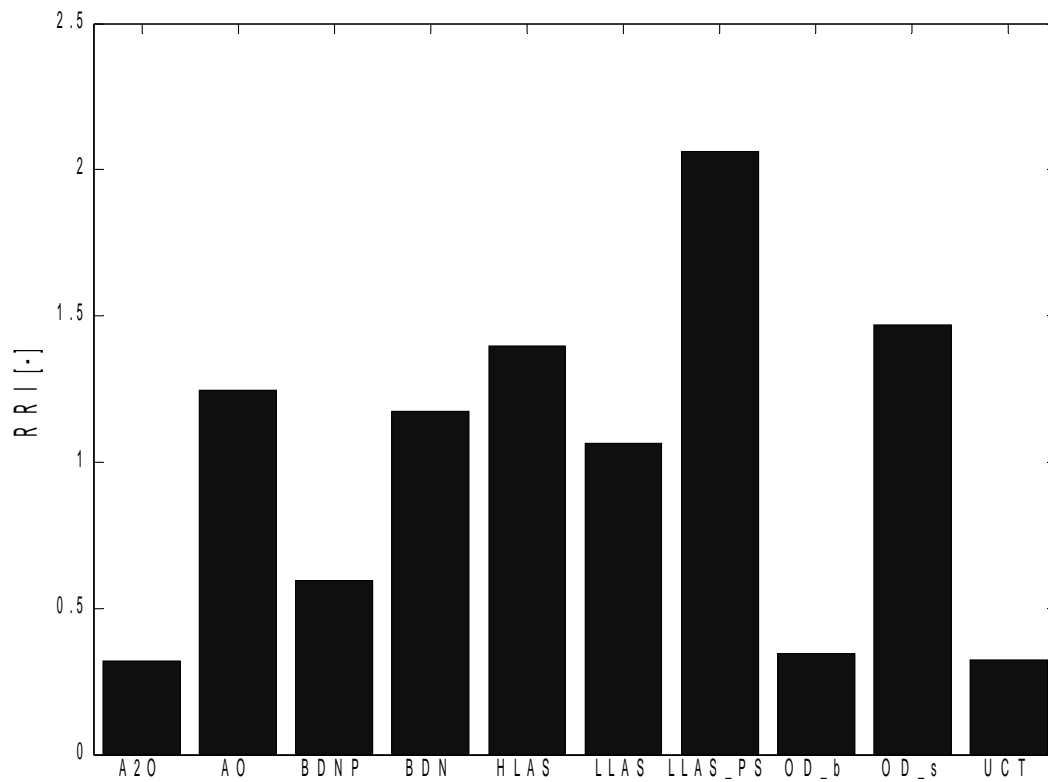

Figure 130: RRI of EQI for ten 30,000PE configurations in Oceanic climate.

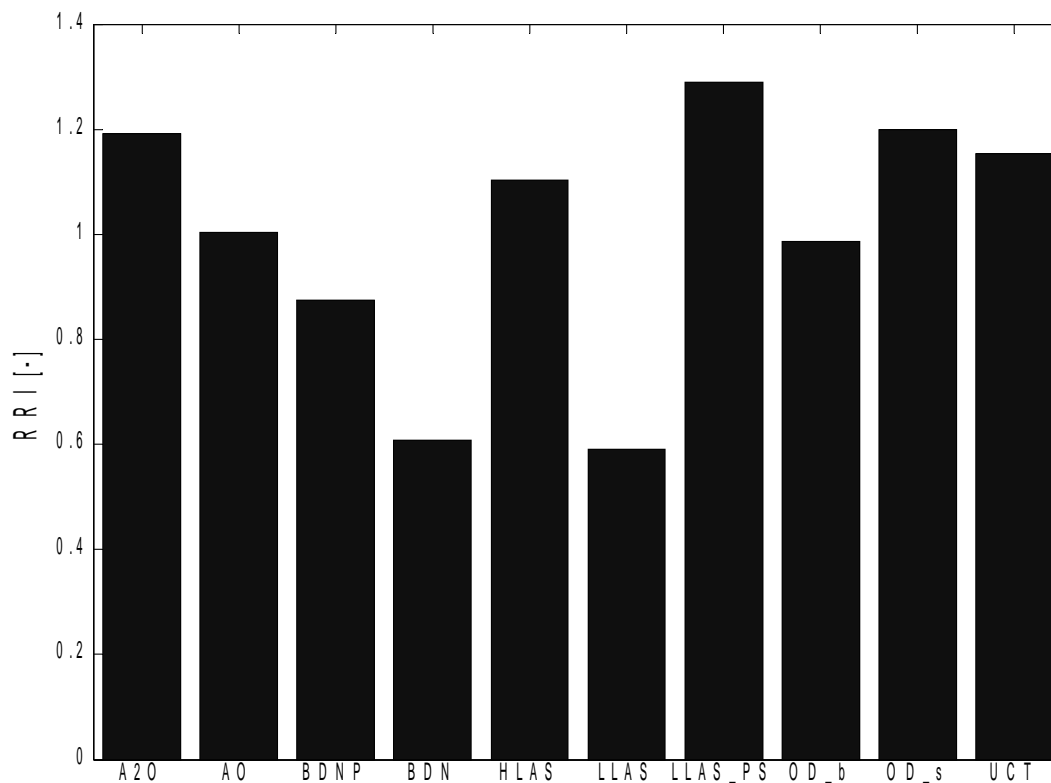

Figure 131: RRI of TC for ten 30,000PE configurations in Oceanic climate.

## Conclusions

The first conclusion is that the HLAS has full costs comparable to nutrient removing systems, but poorer environmental performance. There is therefore no use to implement such system. The second conclusion is that the Biodenitro system shows the lowest TC but relatively high EQI, i.e. lower effluent quality. So it is a question of receiving water quality requirements whether the savings can be better invested in more cost-effective measures, as possible in the flexible context of the WFD. With the conventional emission limits approach, like the one introduced by the EU Urban Wastewater Directive, this configuration would have been discarded from further consideration. Thirdly, it can be noticed that the P-removal plant (AO) has total costs similar to the N- and P-removal plants and only slightly worse environmental performance.

Concerning the environmental performance, all configurations achieve excellent levels due to their generous dimensioning. For all configurations large variability appears in effluent TN and the performance in TN removal is inversely proportional to the performance in  $\text{NH}_4$  removal, due to the difference in effluent nitrate.

Looking at the economic performance of nutrient removal plants, the lowest TC is associated to Biodenitro, which has both low VC and capital costs. The lowest VC is achieved by N- and P-removing plants using the Biodeniphos configuration. These two configurations have both low EC and SC.

## Sensitivity to season

To evaluate the performance of process configurations in critical periods, the case of limited nitrification with cold temperature was chosen. The time window for cold temperature was defined as the period with influent wastewater temperature lower than 12°C. The case of 300,000PE in Continental climate was taken as an example. The results are shown from Figure 132 to Figure 138.

For COD (Figure 132) there is a clear improvement of effluent COD concentrations in the cold period for all configurations. This is due to the larger influent dilution in winter time caused by the higher infiltration in the sewer system. This is confirmed by looking at the COD removal in terms of load (Figure 133) for which slightly lower removal is found for all configurations with cold temperature, with equal incoming load in the two periods.

TN removal almost shows no difference in the two periods, both expressed as exceedance of effluent concentration threshold (Figure 134) and as load removal (Figure 135).

As for TP threshold exceedance (Figure 136), there are small differences, but the direction of change is not the same for all configurations. For example, Biodenitro and OD\_bioP perform better in the cold period, while LLAS, Biodenitro and A2O are better in the warm period, as confirmed by the TP load removal (Figure 137).

As expected, in the cold period all configurations slightly decrease their nitrification in winter time (especially OD\_bioP), but they still achieve good ammonia removal rates thanks to the safety factors included in ATV design (Figure 138). The fact that this effect is not visually detected in the TN effluent analysis, is that the changes in NH<sub>4</sub> effluent are too small compared to the TN effluent.

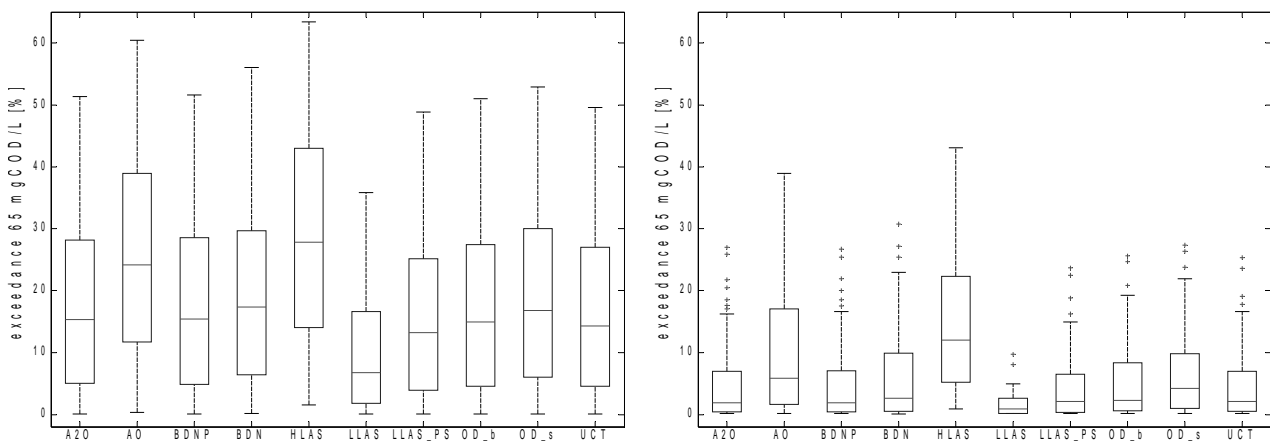

Figure 132: Exceedance time of 65mgCOD/l for ten 300,000PE configurations in Continental climate; full year (left) and cold period (right).

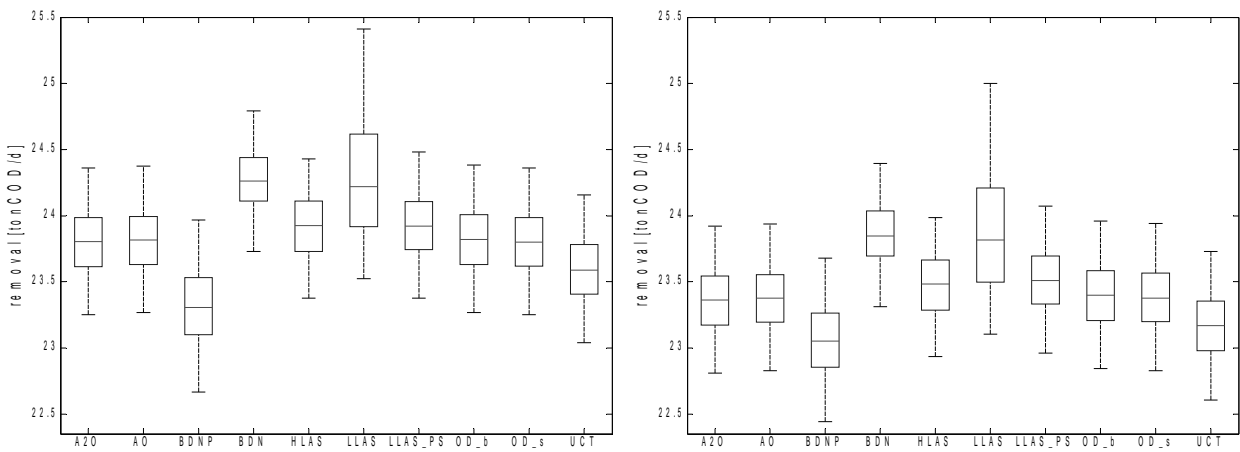

Figure 133: COD load removal for ten 300,000PE configurations in Continental climate; full year (left) and cold period (right).

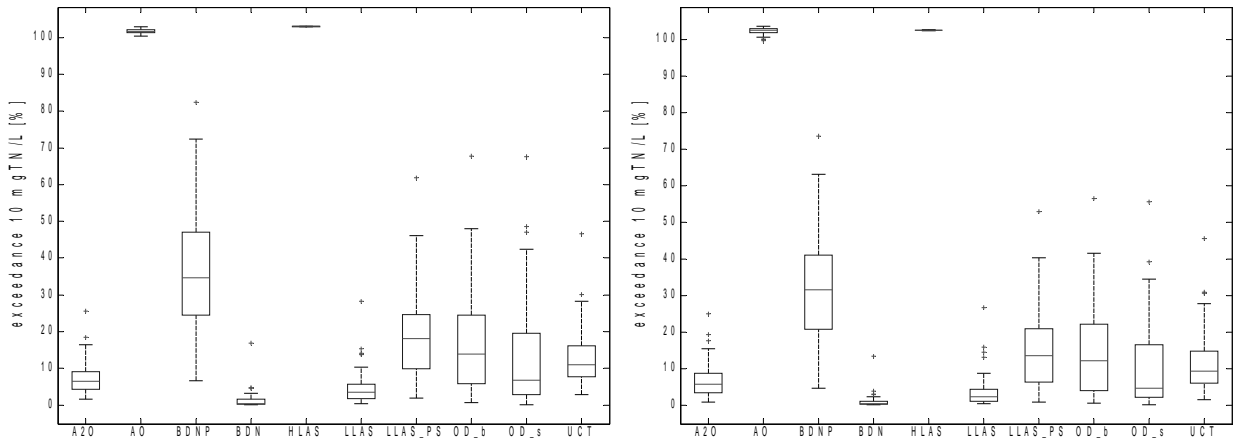

Figure 134: Exceedance time of 10mgTN/l for ten 300,000PE configurations in Continental climate; full year (left) and cold period (right).

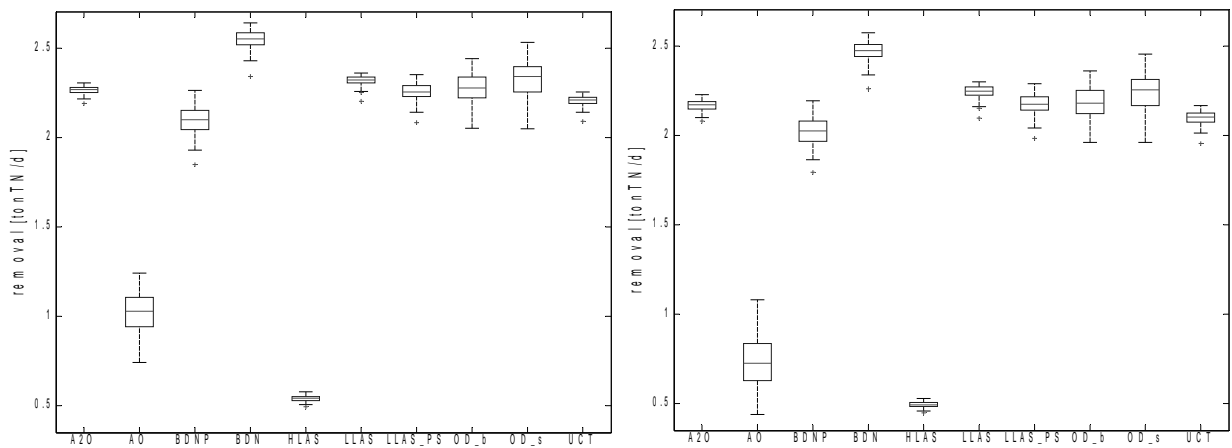

Figure 135: TN load removal for ten 300,000PE configurations in Continental climate; full year (left) and cold period (right).

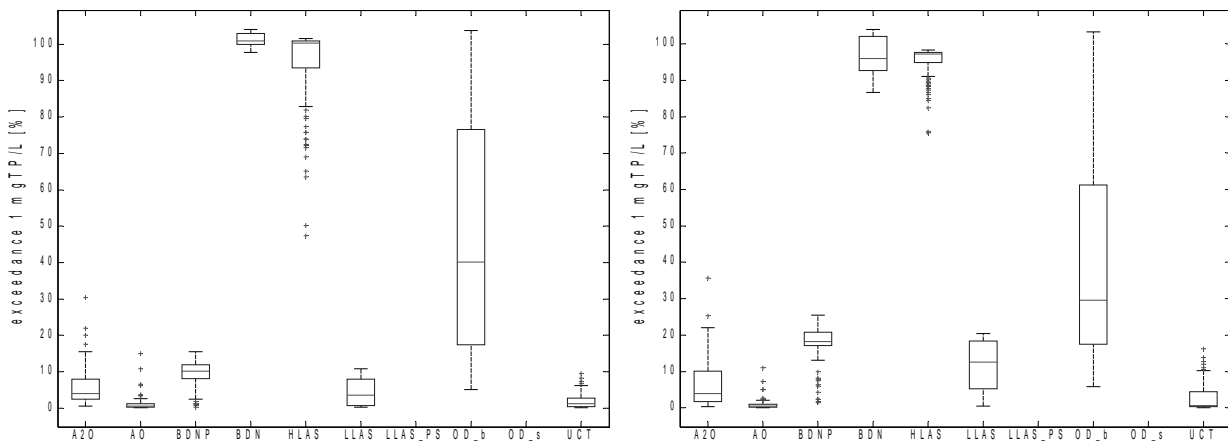

Figure 136: Exceedance time of 1mgTP/l for ten 300,000PE configurations in Continental climate; full year (left) and cold period (right).

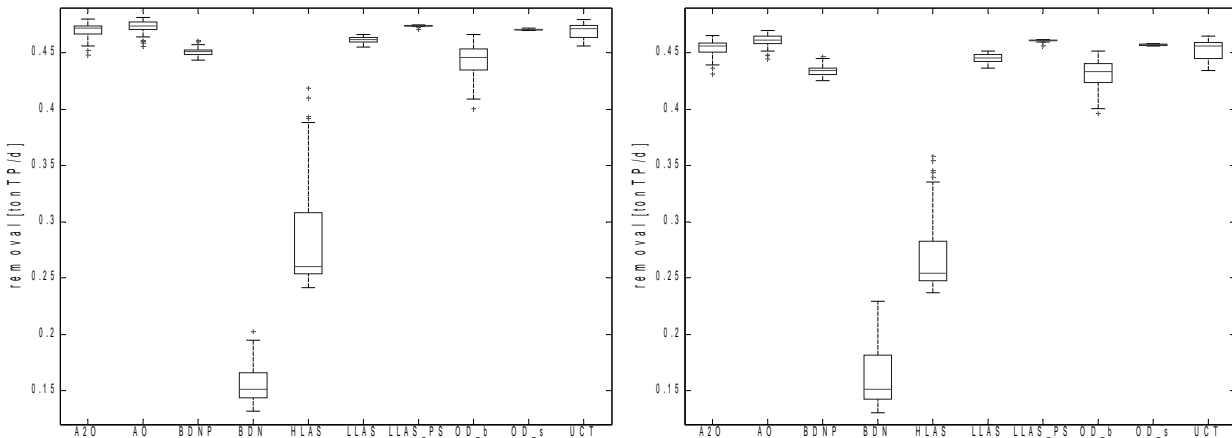

Figure 137: TP load removal for ten 300,000PE configurations in Continental climate; full year (left) and cold period (right).

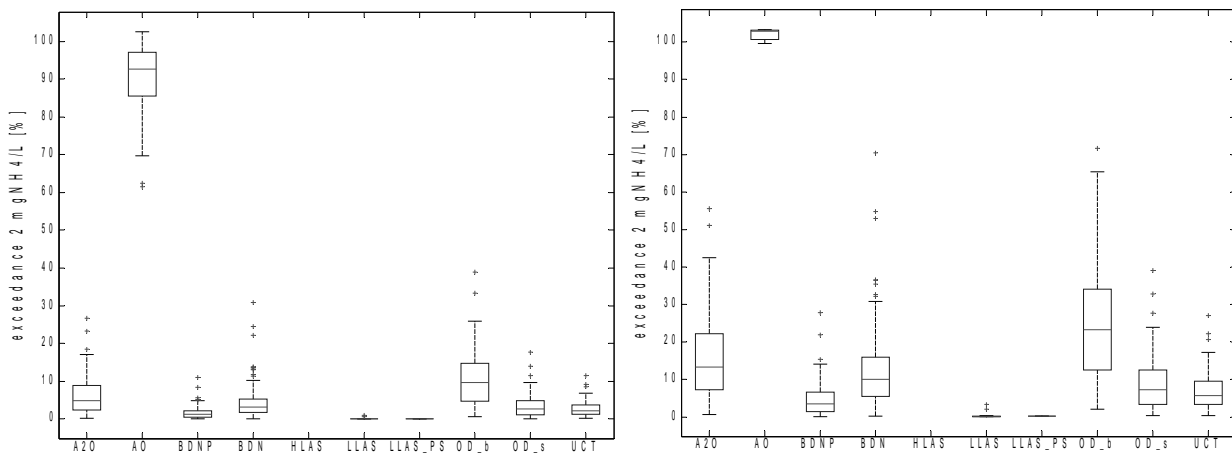

Figure 138: Exceedance time of 2mgNH<sub>4</sub>/l for ten 300,000PE configurations in Continental climate; full year (left) and cold period (right).

### Sensitivity to cost parameters

By comparing the configurations' assessment obtained with the two different cost parameter sets given in Table 35 for 300,000PE in Continental climate, a few conclusions can be drawn.

Looking at the percentile polygons in Figure 139, it can be observed that the Pareto-optimal line changes: Biodenipho is no longer optimal and AO replaces Biodenitro along the cost axis. This is mostly caused by the large difference in sludge costs, which for Eastern Europe reduces the TC of high rate systems (AO and HLAS) and penalises the alternating systems (Biodenitro and Biodenipho), which produce smaller amounts of sludge.

Comparing the left side of Figure 139 with Figure 112 (same cost parameter set but different climate and size), it can be noted that the optimal line is not the same; Biodenitro outperforms AO and OD\_simP substitutes A2O as the configuration with the lowest EQI, but Biodenipho remains the nutrient removing option with the lowest costs.

Concerning the removal efficiencies (Figure 140 to Figure 143), in all charts a general cost decrease for all configurations is evident for the Eastern European cost set, with no difference in the relationships between the configurations' performance, except for the TC/QI ratio (Figure 140) in which the AO and HLAS clearly improve their ranking.

The cost stack charts (Figure 144 and Figure 145) confirm the above analysis.

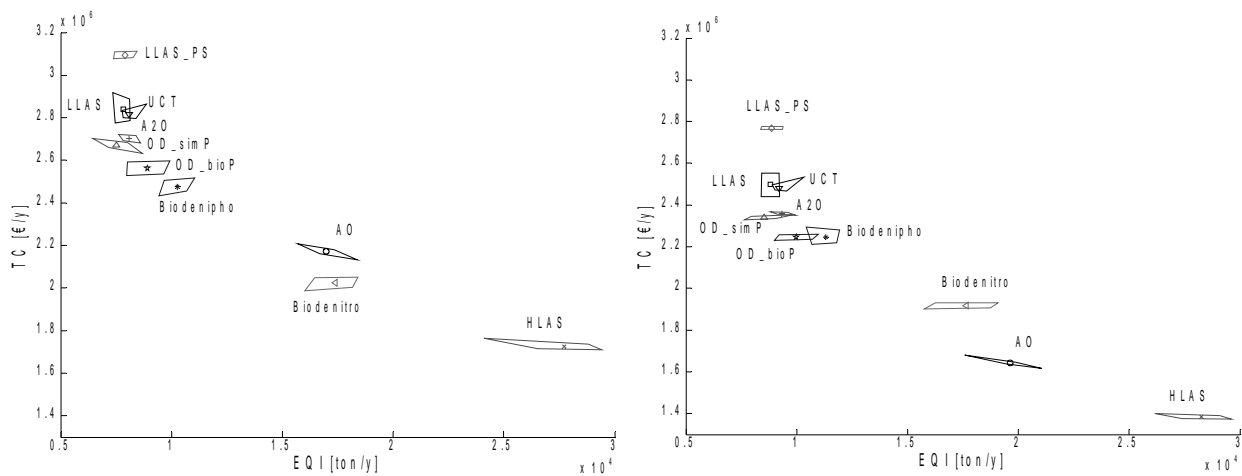

Figure 139: Percentile polygons of EQI and TC for ten 300,000PE configurations in Continental climate; for German cost parameters (left) and for Eastern European ones (right).

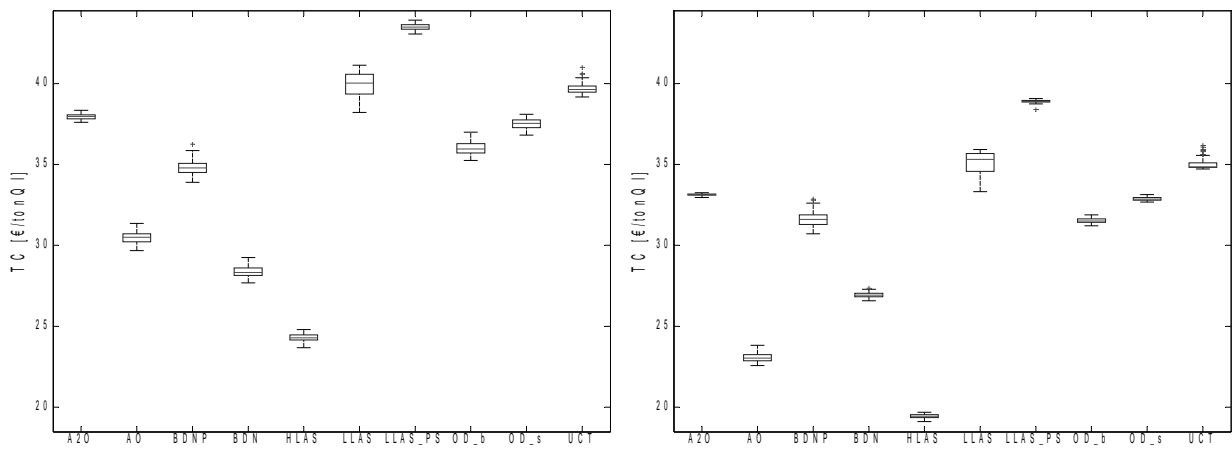

Figure 140: Efficiency of QI removal per TC for ten 300,000PE configurations in Continental climate; for German cost parameters (left) and for Eastern European ones (right).

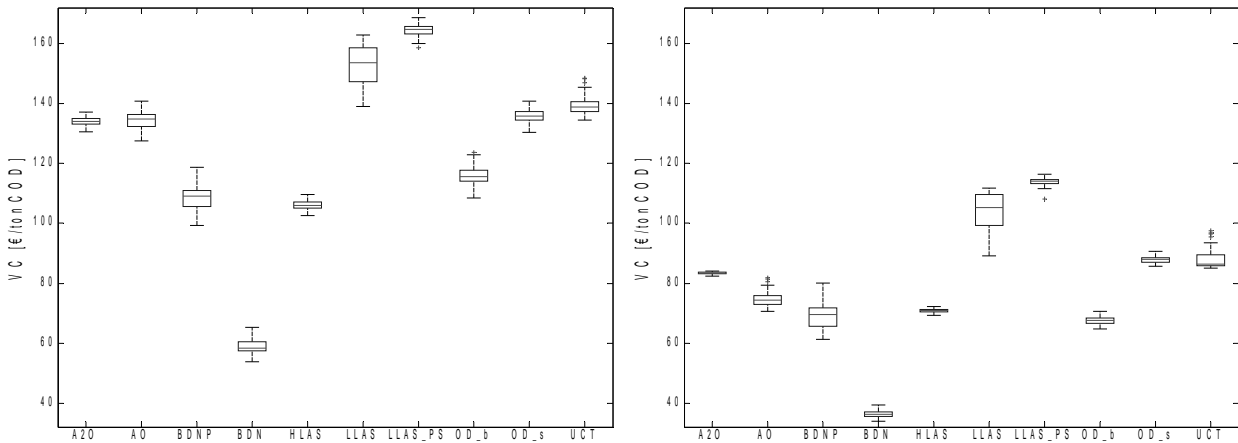

Figure 141: Efficiency of COD removal per VC for ten 300,000PE configurations in Continental climate; for German cost parameters (left) and for Eastern European ones (right).

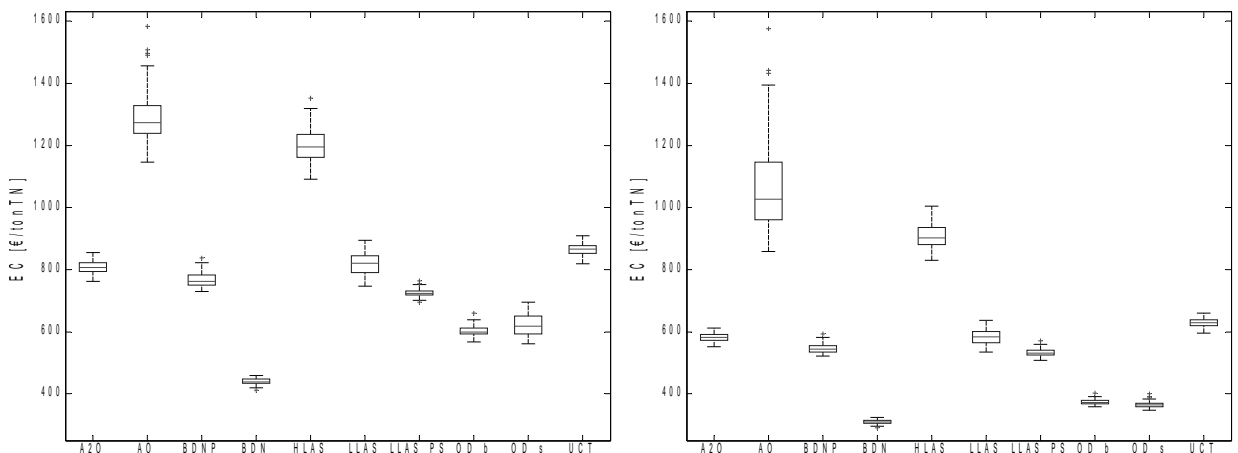

Figure 142: Efficiency of TN removal per EC for ten 300,000PE configurations in Continental climate; for German cost parameters (left) and for Eastern European ones (right).

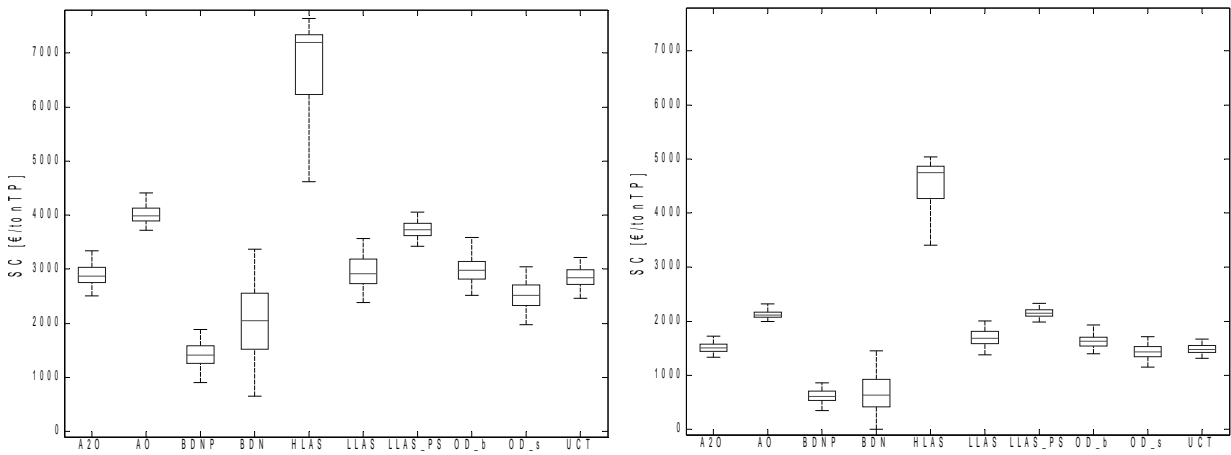

Figure 143: Efficiency of TP removal per SC for ten 300,000PE configurations in Continental climate; for German cost parameters (left) and for Eastern European ones (right).

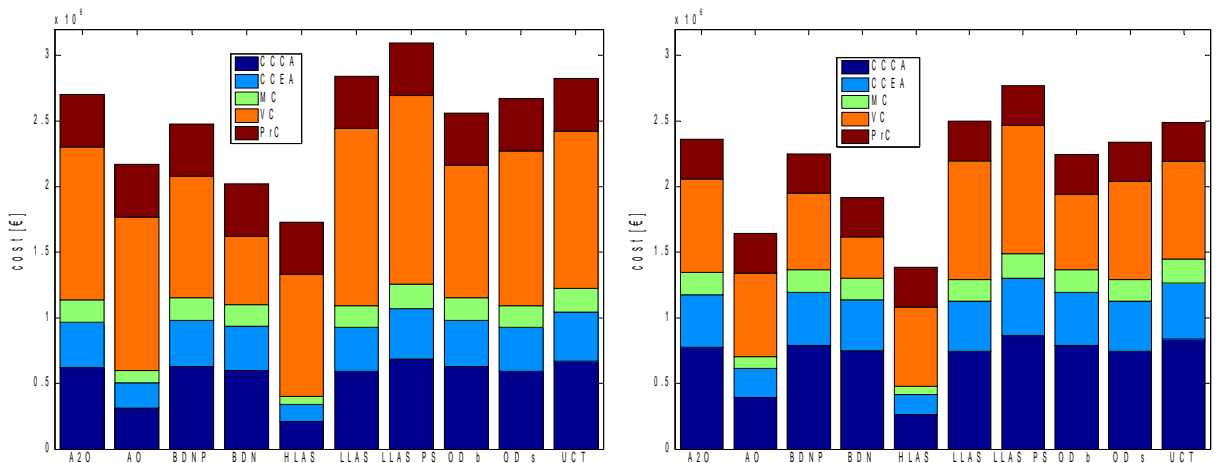

Figure 144: Total costs for ten 300,000PE configurations in Continental climate; for German cost parameters (left) and for Eastern European ones (right); C C C A=capital cost for construction annualised, C C E A=capital cost for equipment ann., M C=maintenance cost, V C=variable cost, P r C=personnel cost.

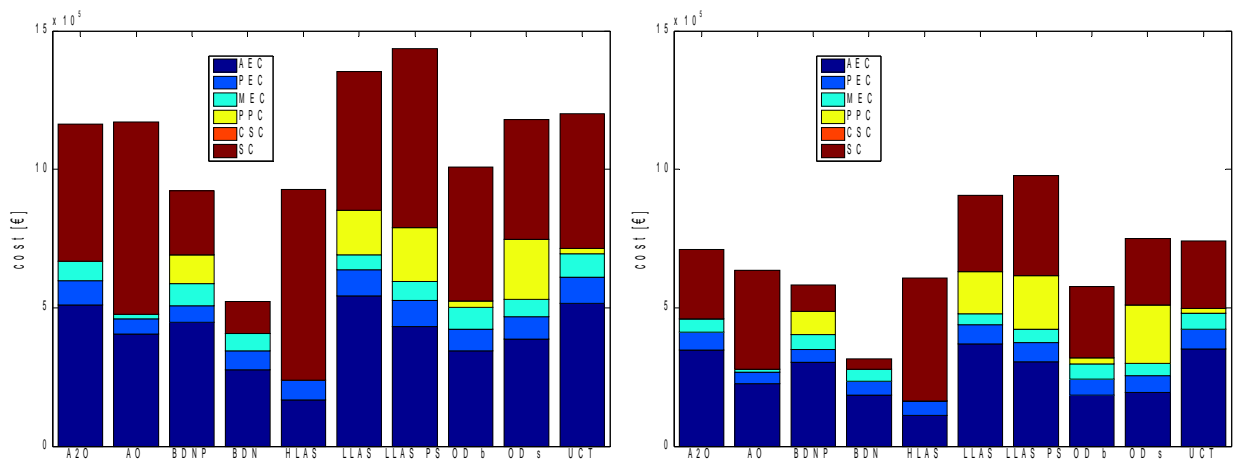

Figure 145: Variable costs for ten 300,000PE configurations in Continental climate; for German cost parameters (left) and for Eastern European ones (right); A E C= aeration energy cost, P E C=pumping energy cost, M E C=mixing energy cost, P P C=P-precipitant cost, C S C=C-source cost, S C=sludge cost.



### 12.2.2 WWTP UPGRADE

The performance of the different upgrade scenarios presented in Section 9.2.2 and Appendix C was evaluated using the NH<sub>4</sub>, TN and TP effluent concentration and the EQI and the effluent violations for COD (>80mg/l), NH<sub>4</sub> (>2mg/l), TN (>10mg/l) and TP (>1mg/l). The percentage of time that the constraints were not met was calculated from the simulation output data generated at 15-minute intervals. The same operational costs as for WWTP design evaluation have been adopted.

The effect of climate on the efficiency of upgrades is also compared in this section, by performing the evaluation in both Continental and Mediterranean climate conditions.

Figure 146 to Figure 158 show the results of the simulations. The meaning of the upgrade abbreviations can be found in Table 20 and is repeated here:

- **U0**: Reference case with no upgrade
- **U1**: Increase of aerated tank volume by 33%
- **U2**: U1 + increase of final clarifier area by 33%
- **U3**: U1 + pre-anaerobic tank + C dosage to denitro + lower DO set-point
- **U4**: Dosage of external carbon source
- **U5**: DO control based on ammonia
- **U6**: Internal recycle control based on nitrate
- **U7**: U4 + U6
- **U8**: Spare sludge storage
- **U9**: Sludge wastage control
- **U10**: Dynamic step feed
- **U11**: Increase in anoxic volume, decrease in aerated volume
- **U12**: Buffering ammonia peak loads with the storm tank

In terms of variable costs, U4 is quite expensive due to the consumption of C-source. Therefore it should only be applied if effluent nitrogen levels are higher than the applicable standards. For the Mediterranean climate, this is not the case when the yearly average nitrogen and ammonia concentrations in the effluent are evaluated. For this reason, U4 was only incorporated into the comparison of different upgrade scenarios for the Continental and not for the Mediterranean climate. U11 was only included in the comparison for the Mediterranean climate, since in Continental climate it was not able to nitrify sufficiently.

Concerning the MLSS concentration in the activated sludge tanks, it was set for all upgrades to 3.5g/l in summer and 4.5g/l otherwise, with summer defined as the period with mixed liquor temperature above 16°C.

#### Economic performance

The economic performance was evaluated on the basis of the difference in costs of the upgrade (including U0) associated to the 400.000PE influent minus the costs of U0 fed by the 300.000PE influent.

In terms of total costs (Figure 146), the “hard” upgrades U1, U2 and U3 (together with U7 in Mediterranean climate, as explained below), which involve mainly constructional intervention, are

clearly more expensive than the RTC upgrades. For the variable cost plots (Figure 147), U3 is almost double than most of the other upgrade options, due to the addition of external carbon source.

Figure 151 illustrates that the majority of total costs is due to variable costs and that capital costs are definitively minor. Figure 152 shows that variable costs are mostly constituted by aeration, that P-precipitant and sludge costs are of similar magnitude and that the main differences are due to the presence of C-source dosage. Although it might seem from these figures that all upgrade options have total annual costs that are nearly the same as U0, it should be stressed that the difference between the most and the least expensive scenarios is about € 500,000 per year, which means that in absolute terms there is certainly a difference that is worth some consideration.

The larger volumes of “hard upgrades” entail also higher energy costs (Figure 148) mostly due to higher aeration costs as shown in Figure 150, where a general trend can be noticed with lower NH<sub>4</sub> effluent concentrations related to higher aeration costs.

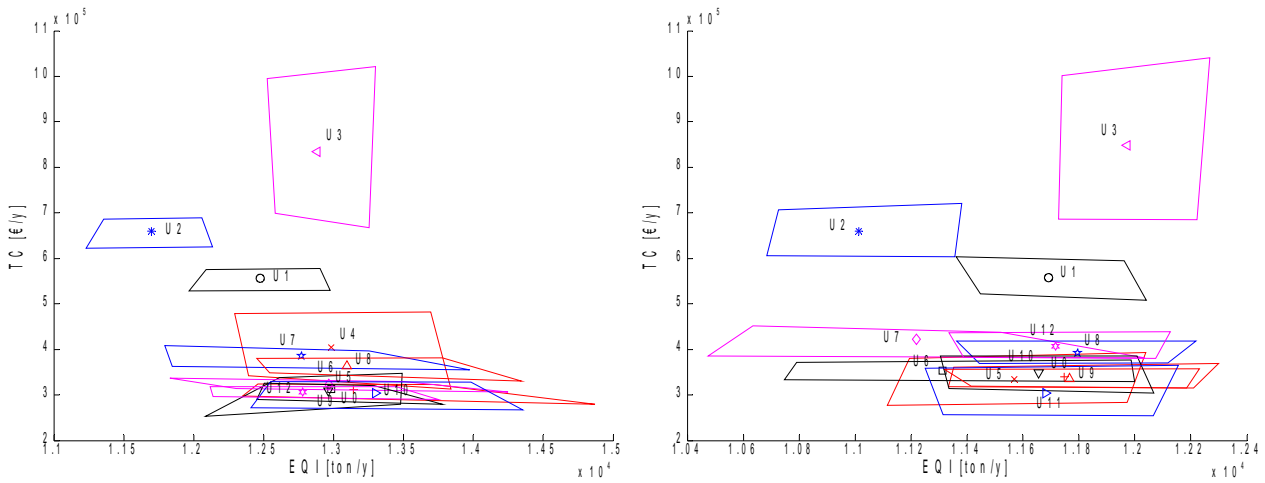

Figure 146: EQI and TC for LLAS 300,000PE upgrades in Continental (left) and Mediterranean (right) climates.

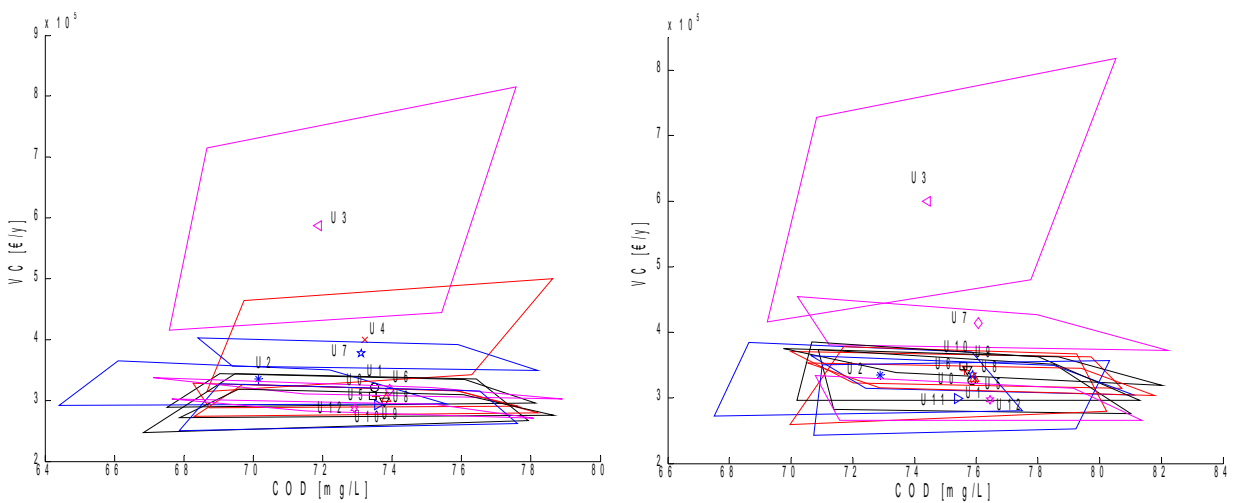

Figure 147: COD and VC for LLAS 300,000PE upgrades in Continental (left) and Mediterranean (right) climates.

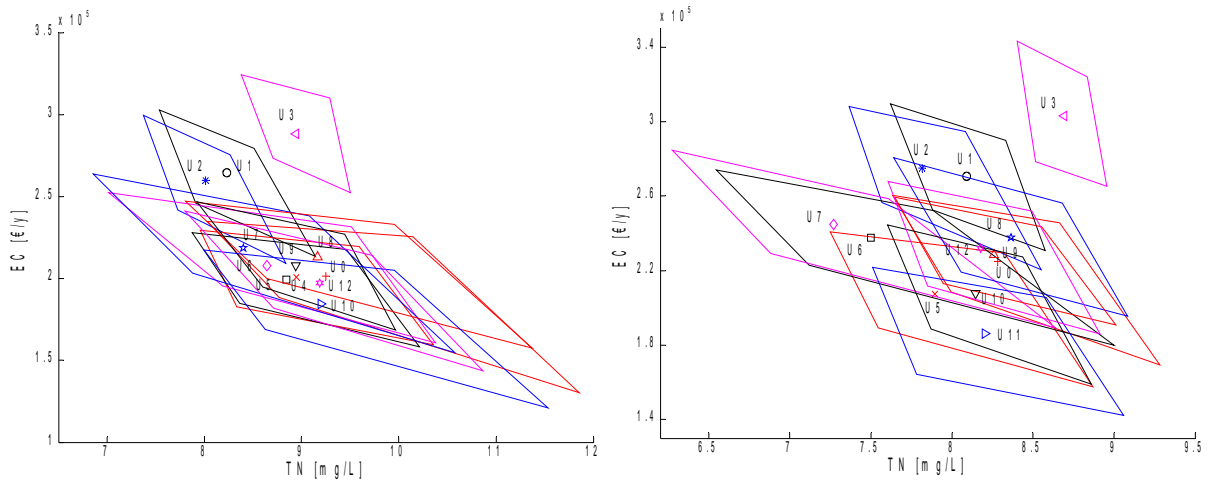

Figure 148: TN and EC for LLAS 300,000PE upgrades in Continental (left) and Mediterranean (right) climates.

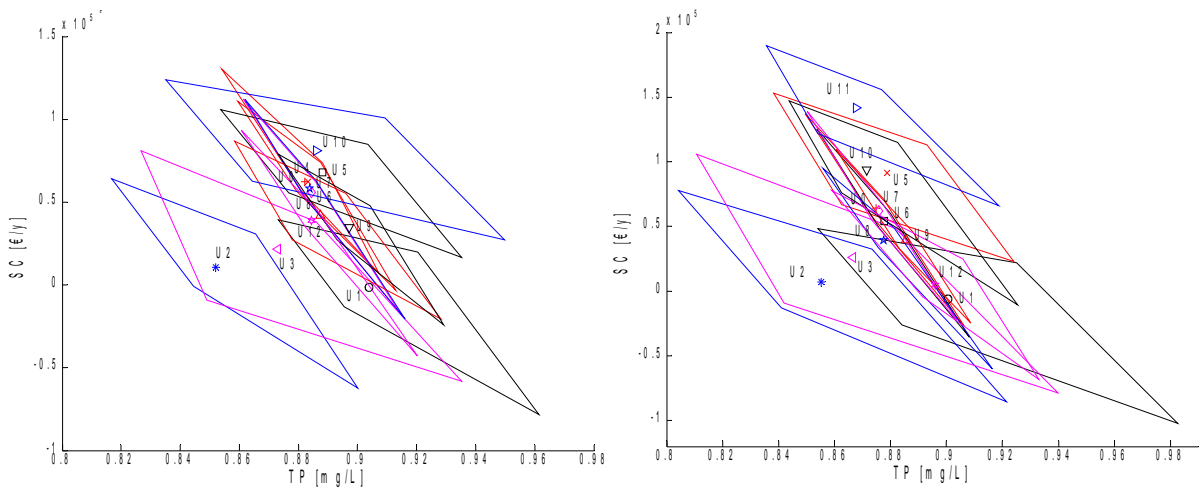

Figure 149: TP and SC for LLAS 300,000PE upgrades in Continental (left) and Mediterranean (right) climates.

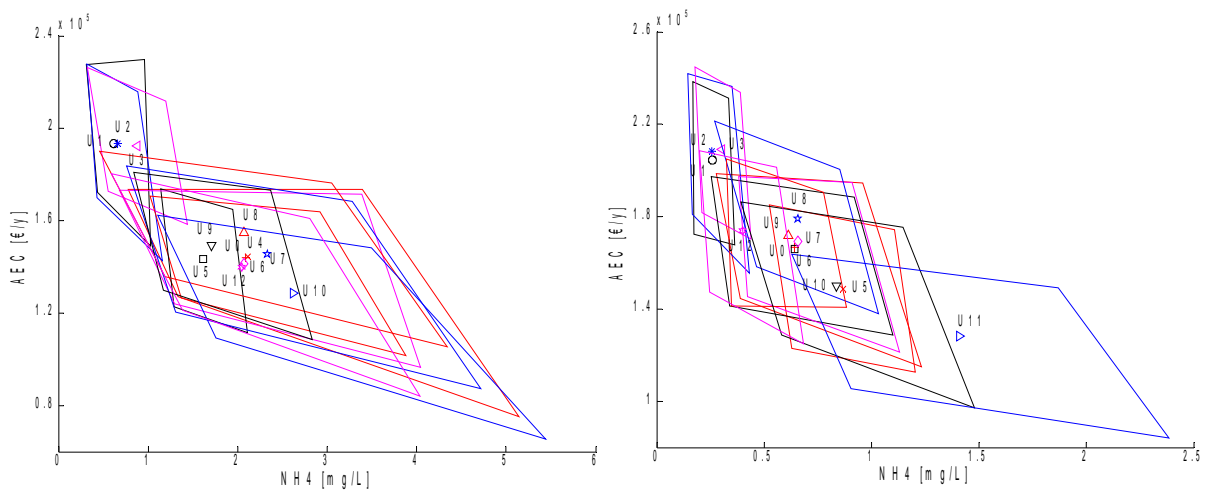

Figure 150: NH<sub>4</sub> and AEC for LLAS 300,000PE upgrades in Continental (left) and Mediterranean (right) climates.

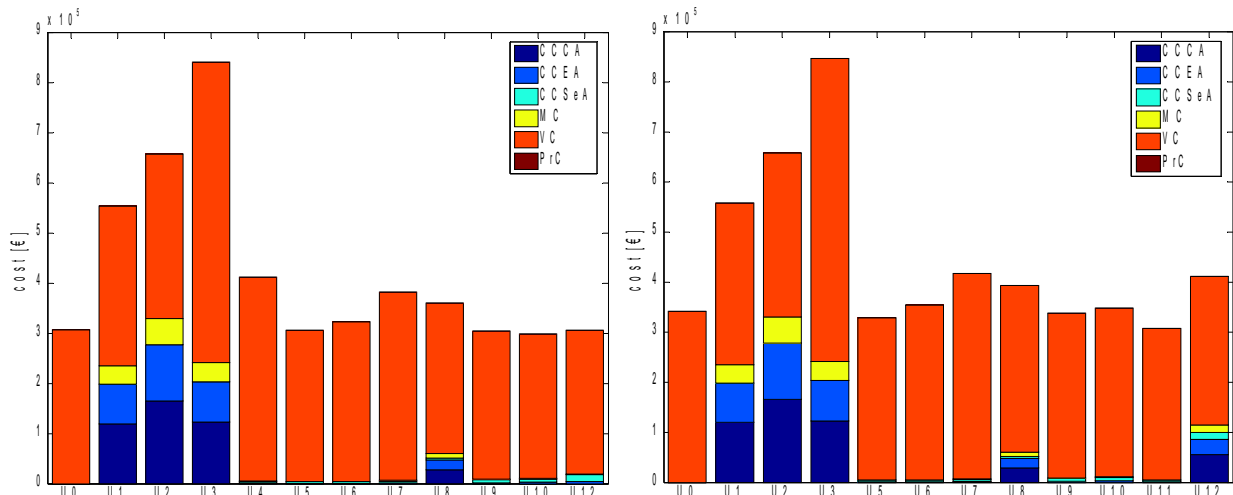

Figure 151: TC for LLAS 300,000PE upgrades in Continental (left) and Mediterranean (right) climates; C C C A=capital cost for construction annualised, C C E A=capital cost for equipment ann., C C S e A=capital cost for sensors ann., M C=maintenance cost, V C=variable cost, P r C=personnel cost.

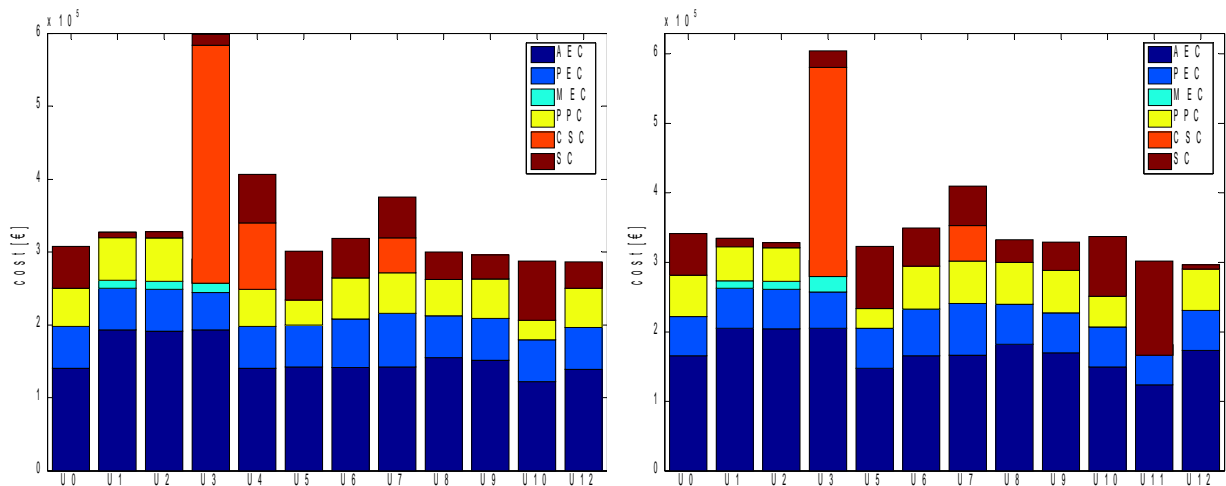

Figure 152: VC for LLAS 300,000PE upgrades in Continental (left) and Mediterranean (right) climates; A E C= aeration energy cost, P E C=pumping energy cost, M E C=mixing energy cost, P P C=P-precipitant cost, C S C=C-source cost, S C=sludge cost.

### Environmental performance

It can be noticed that U2 shows the best environmental performance in Continental climate conditions (Figure 146 to Figure 150), together with U7 in Mediterranean climate, especially for TN (Figure 148). All upgrades have a 50<sup>th</sup> percentile EQI that is lower than that of U0 in Continental conditions (Figure 146). In Mediterranean conditions this is not the case, but it should be considered that for the Mediterranean condition the EQI of U0 was already more than 10% lower than in Continental conditions.

Concerning the effluent concentrations, it can be seen that almost all upgrades have better nitrogen removal than U0. Because of the less favourable conditions for nitrification in the Continental climate, the box plots in Figure 158 show a larger vertical spread compared to the Mediterranean plots on the right side. This is also reflected in Figure 148 and Figure 150, where the

50<sup>th</sup> percentile values are higher and the 5<sup>th</sup>/95<sup>th</sup> percentile intervals are larger for the Continental than for the Mediterranean plots. These figures show that U2 performs better than U1 concerning TN removal, but not with regard to effluent ammonia concentrations, which are about the same in both scenarios. This means that U2 has better denitrification performance. This can partly be attributed to the larger final clarifier, in which it is assumed that anoxic processes take place in the lower part of the sludge blanket.

When comparing the results of the first three upgrade options, which all require the construction of additional volumes, it can be seen that U2 always performs better than U1 and U3. The difference with U1 proves that an extension of the final clarifier area (U2) is a clear added value to the increase in aerated volume (U1). U3 aims at a biological phosphorus removal by adding extra anaerobic tank volume and dosage of external carbon source. In spite of those extra investments, the figures show that the environmental performance of U3 is worse than that of U1 and U2. The higher effluent ammonia and TN concentrations in U3 can be attributed respectively to the lower DO set-point used – an attempt to lower the aeration costs – and to the introduction of biological phosphorous removal before the denitrification tank, which lead to the use of most of the carbon source by the PAOs, which in turn decreases the denitrification performance.

The poor performance of U10 concerning nitrogen removal in Continental conditions (Figure 148 and Figure 154), indicates that the loss of nitrification capacity due to the decrease in aerated volume can not be compensated by the benefits of the increased anoxic tank volume for denitrification.

From Figure 149 and Figure 156, it can be concluded that the upgrade scenarios do not show clear benefits regarding phosphorus removal compared to U0, except for U2. This is because no process alterations have been made regarding the precipitant dosage controller. Modifications of the system have therefore not been counteracted by changes in the controller settings. The biological phosphorus removing upgrade that was simulated in U3 is not capable of keeping the effluent TP concentration at the same low level as is achieved with chemical P removal only. On the other hand, Figure 149 shows that in all scenarios the annual mean effluent TP concentration is kept below the limit of 1mg/l in all simulations.

As for the exceedance frequencies, the COD effluent (see Figure 153, but also Figure 147 for the concentrations) is higher for the Mediterranean climate because the influent is less diluted than in the Continental climate. The COD removal is approximately the same in the two cases. U2 performs slightly better than all the other upgrades. Concerning the TN exceedance (Figure 154) and RRI (Figure 155), in the Continental climate U1, U2 and U3 look more stable and less risky, while in the Mediterranean climate U7 outperforms all other upgrades but it is also the least reliable. For TP threshold exceedance (Figure 156) and RRI (Figure 157), there are no large differences in performance. To be noted is that larger volumes lead in general to a higher exceedance risk and larger variance due to the slower response of the controller to variations in the input; on the other hand, their RRI is higher since it is based on the yearly effluent averages. As expected, NH<sub>4</sub> exceedances (Figure 158) are more frequent in the Continental climate than in the Mediterranean climate and “hard upgrades” perform better than the others. It is to be noted that U11 has a particularly high risk of exceedance, due to the reduction in aerated volume introduced to save aeration energy, but it is also the most reliable upgrade in terms of yearly average (Figure 159).

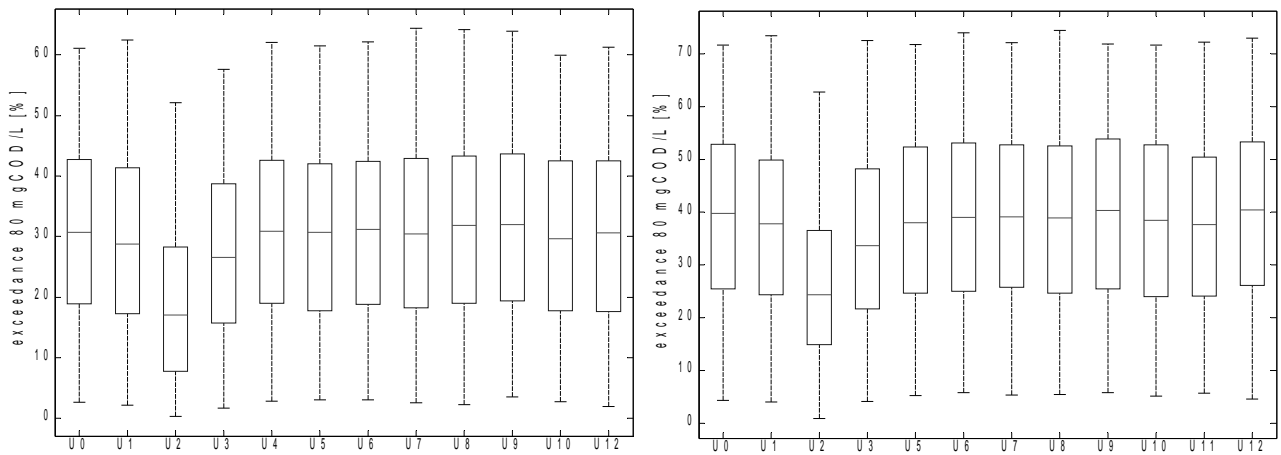

Figure 153: Exceedance time of 80mgCOD/l for LLAS 300,000PE upgrades in Continental (left) and Mediterranean (right) climates.

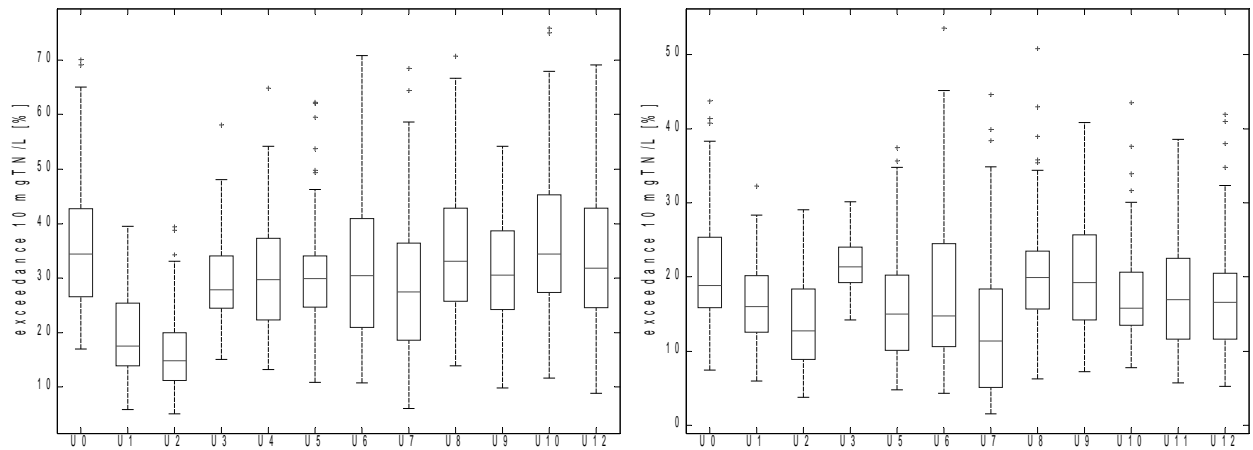

Figure 154: Exceedance time of 10mgTN/l for LLAS 300,000PE upgrades in Continental (left) and Mediterranean (right) climates.

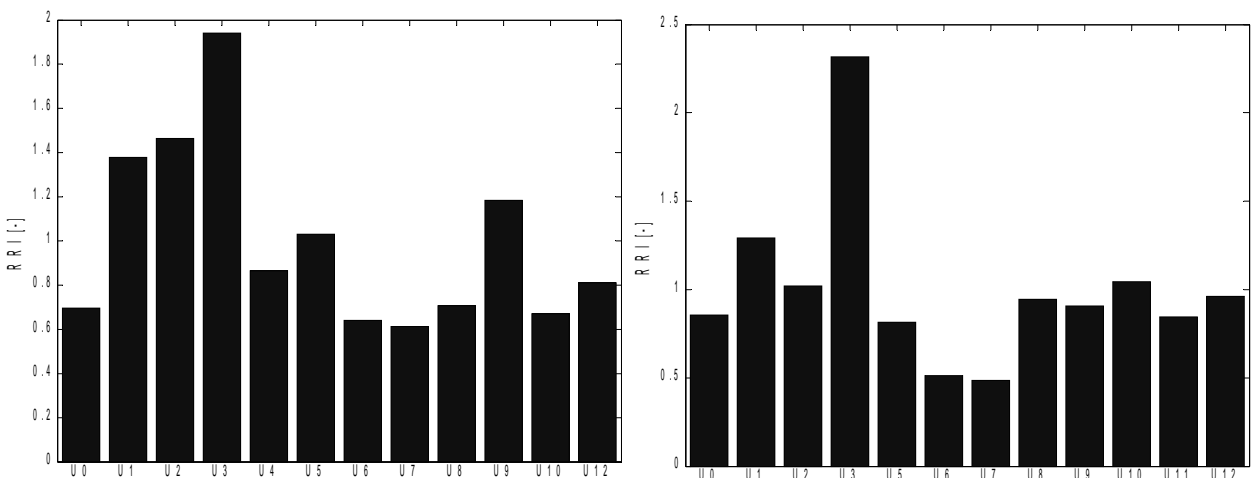

Figure 155: RRI of TN for LLAS 300,000PE upgrades in Continental (left) and Mediterranean (right) climates.

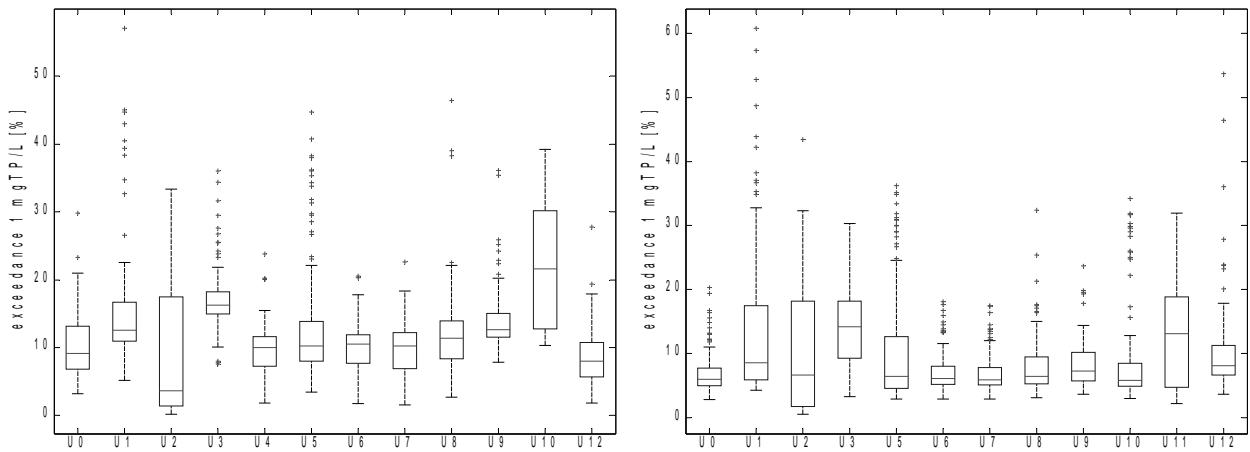

Figure 156: Exceedance time of 1mgTP/l for LLAS 300,000PE upgrades in Continental (left) and Mediterranean (right) climates.

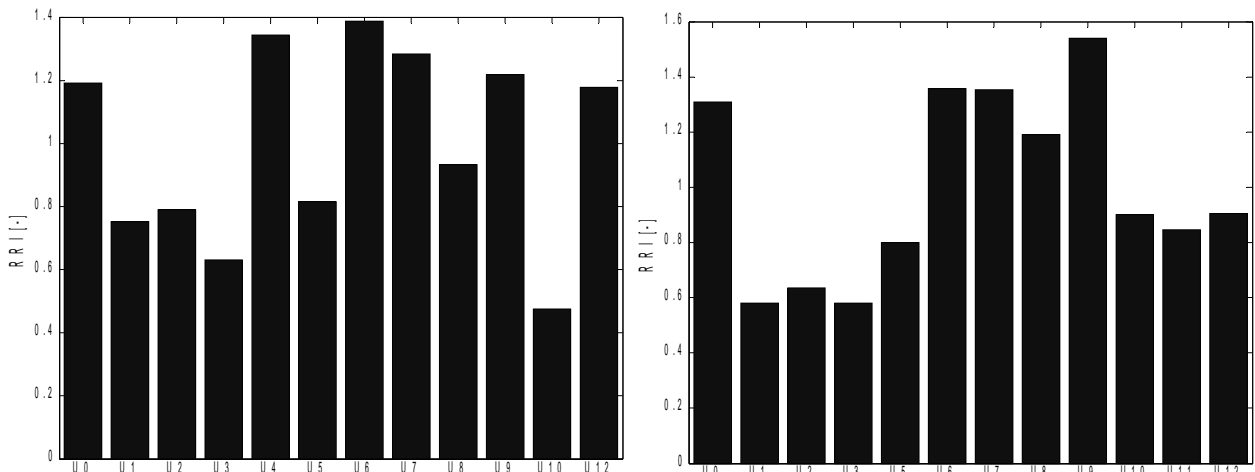

Figure 157: RRI of TP for LLAS 300,000PE upgrades in Continental (left) and Mediterranean (right) climates.

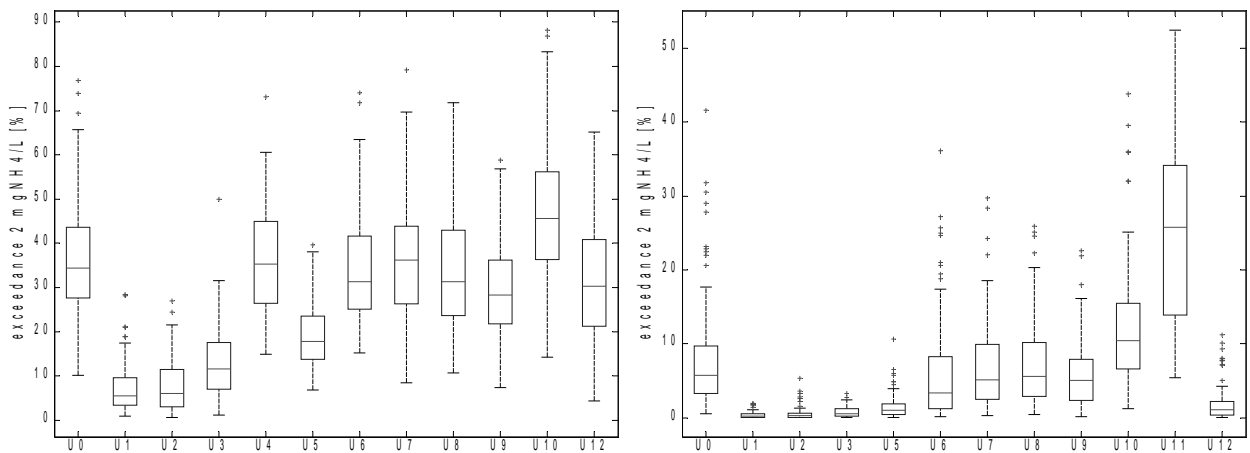

Figure 158: Exceedance time of 2mgNH<sub>4</sub>/l for LLAS 300,000PE upgrades in Continental (left) and Mediterranean (right) climates.

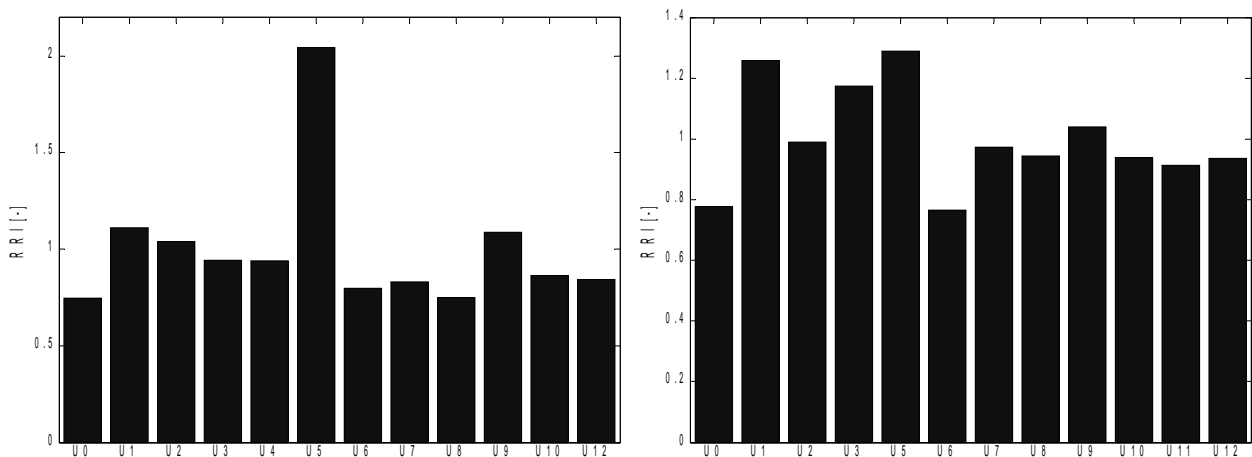

Figure 159: RRI of  $\text{NH}_4$  for LLAS 300,000PE upgrades in Continental (left) and Mediterranean (right) climates.

## Conclusions

It is not straightforward to draw conclusions from the extensive amount of simulation results presented above. Almost none of the studied upgrades shows an outstanding performance compared to the reference scenario U0 and only a few options can be eliminated because of unsatisfying performance. In the following, some major findings are summarised for each upgrade scenario that was included in the comparison.

U1, U2 and U3 are upgrades which involve the construction of additional volumes. It is clear that U2 shows a remarkably better environmental performance than U1, so the addition of extra settling area (U2) means a precious added value to the extension of aerated volume (U1). Longer retention times do help in improving effluent quality. No RTC upgrade proved to be more performing than U1 and U2 (especially in Continental climate) which on the other hand are definitively more expensive.

In U3, not only extra aeration and denitrification volumes but also the biological phosphorus removal process was added to the existing configuration by means of an anaerobic volume. The biological P removal process reduces the need for precipitation chemicals, but brings up the need for addition of an external carbon source. The net effect is an increase in costs. Biological P removal in the tested set-up resulted in slightly higher effluent TP concentrations than chemical precipitation, although for none of the studied scenarios there were problems with P effluent limit violations.

Besides U3, also U4 and U7 use carbon source addition as a control strategy to assure good denitrification. This results in higher operating costs compared to the other RTC upgrades. On the other hand, carbon source addition proves to be an efficient means to control the nitrate level in the anoxic tank at a predefined set-point. Noticeably, the environmental performance of U7 seemed to be much better in Mediterranean than in Continental climate conditions.

Simulation results of U5 show that the control strategy is capable of keeping the effluent ammonia concentration at or below a chosen set-point. Effluent standards exceedance time is decreased by allowing a more dynamic aeration control and aeration costs are diminished by



avoiding over-compliance. This effluent quality improvement together with the low installation effort – only one ammonia sensor has to be installed – makes this upgrade option a scenario worth consideration.

Control of the internal mixed liquor recycle rate was explored in U6. The proposed strategy was to control the nitrate concentration in the anoxic tank at a certain set-point by adjusting the internal recycle flow-rate. This strategy yielded better results than the original ratio control that was incorporated in U0. Increasing the average and maximum allowed recycle flow-rate also yielded potential benefits in effluent quality.

Two RTC strategies with regard to sludge control were tested. In U8, spare sludge was stored and added to the system, based on the automatic detection of ammonia peak loads in the plant influent. The benefits of spare sludge addition, which is basically maintaining a higher TSS concentration in the aerated tanks, are only relevant during winter and spring time. This finding was exploited in U9, where RTC of sludge wastage (based on the ammonia concentration in the aerator) was allowed to apply higher TSS concentrations than in U0. Concerning effluent quality, the improvement compared to U0 was only slight, but U9 proved to be more cost effective and more robust. Compared to other, more complex RTC upgrade scenarios, this simple upgrade option is certainly worth consideration.

U10 (step-feed) in its investigated implementation does not show good effluent performance – especially in Continental climate – probably because of the fact that part of the influent by-passes part of the treatment, without benefiting significantly from the flexibility of the system.

In U11, the aerated volume was adjusted according to the ammonia concentration in the effluent of the tank. Beneficial effects were noticed in terms of effluent quality, but operating costs were higher than when a constant DO set-point was set – although the aim of the control strategy was rather to decrease aeration energy costs rather than to improve effluent quality.

U12, buffering ammonia peak loads within the storm tank, resulted in the best RTC upgrade option for the Continental climate, while for the Mediterranean climate U6 and U7 show the best results.

## 12.3 Conclusions

The end-product of the probabilistic design methodology was presented, consisting in the evaluation of alternative options. In particular, this chapter described the emission-based evaluation.

The newly introduced probabilistic descriptors – especially the percentile polygons and the exceedance threshold box-plots – proved to be valuable instruments for the probabilistic analysis and comparison of several alternatives.

As for the process volumes dimensioning analysis, it can be concluded that building activated sludge volumes down to 60% of the ones traditionally calculated by applying ATV design guidelines leads to considerable total cost reductions, while it entails only a small increase in the risk of not complying with yearly average emission standards. Sixty percent actually corresponds to the safety factor implicit in the ATV guidelines for the studied plant size.

Considering the ten different process configurations compared, alternating systems show the best cost-benefit performance (TC per QI removed) under the given boundary conditions, while high-loaded systems show the lowest. When limiting the analysis to the cold period only, the results show slight differences compared to a full year analysis, in particular due to the higher infiltration

(dilution) and lower temperature (decreased nitrification) in winter time. These differences are not very significant because of the generous dimensioning of the volumes. The ranking of configuration options is rather sensitive to cost parameters and especially to sludge costs.

With regard to WWTP upgrading, an overall conclusion is that some RTC upgrades clearly show beneficial effects on nitrogen removal and on effluent quality in general. However, when the nitrification process is the bottleneck in unfavourable conditions (like winter and spring time in the Continental climate), the construction of extra volume might be unavoidable to meet stringent effluent limits.

As a general conclusion, the comparison with the safety factor adopted in the ATV guidelines is a confirmation of the validity of the model-based design method. Furthermore, the large safety factor of ATV is not only intended to deal with the uncertainties regarding operation, but also because the German legislation sets effluent limits to 2-h samples (for 4 samples on 5, while the 5<sup>th</sup> should not exceed the given limit by more than 100%), while the design at 60% of the ATV volume only respects yearly averages for effluent nutrient concentrations.

It is not advocated that ATV guidelines should be changed, but it is here stressed that they are specifically developed to fulfil the German effluent quality regulations. Nevertheless, the advantages of the method proposed in this dissertation can be exploited also in the presence of such regulations, since the risk of exceedance can be quantified and made explicit and compared with the “dynamic” and “probabilistic” German limits (2-h samples and 80% compliance).

The main advantage of the proposed method is that it is very transparent and flexible, which means that the appropriate treatment level (process volume) can be found as a function of the local given effluent limits – in terms of averages, grab or composite samples, percentiles of exceedance frequency, etc. – and of the associated local treatment costs (total or operational).

An important conclusion remains, however, that the application of ATV design guidelines to very different environmental, economic and legislative conditions can lead to inefficient solutions.

## IMMISSION-BASED EVALUATION OF ALTERNATIVES

Water quality standards are already incorporated in most of the current legislations in most countries. The immission-based evaluation (see Figure 160) – subject of this chapter – allows to identify the effect of measures on water quality and is complementary to the emission-based evaluation which is also part of the “combined approach” introduced by the WFD.

An example of WWTP upgrade comparison with the “combined approach” is given, showing how conclusions can be different by performing the emission-based evaluation only.

### 13.1 Evaluation framework

The assessment of the effect of different WWTP upgrades on the receiving water quality is done by analysing quality variables in one or more points of the river. In this study, the yearly averages and exceedance periods of limits were taken from the last tank of the river model (5.000m downstream the WWTP effluent) for DO and from the first tank (1.000m downstream the WWTP effluent) for  $\text{NH}_4$ ,  $\text{NO}_3$ ,  $\text{PO}_4$  and COD, which are considered as the critical sections for those water quality parameters.

The values of the limits for the exceedances were taken arbitrarily in a way to be able to compare in the same figures the three considered upgrade options. With some thresholds, one or more options had exceedance values out of scale (0% or 100%).

As for the economic evaluation, there is no difference with the emission-based approach, therefore no emphasis is put on the subject in this chapter.

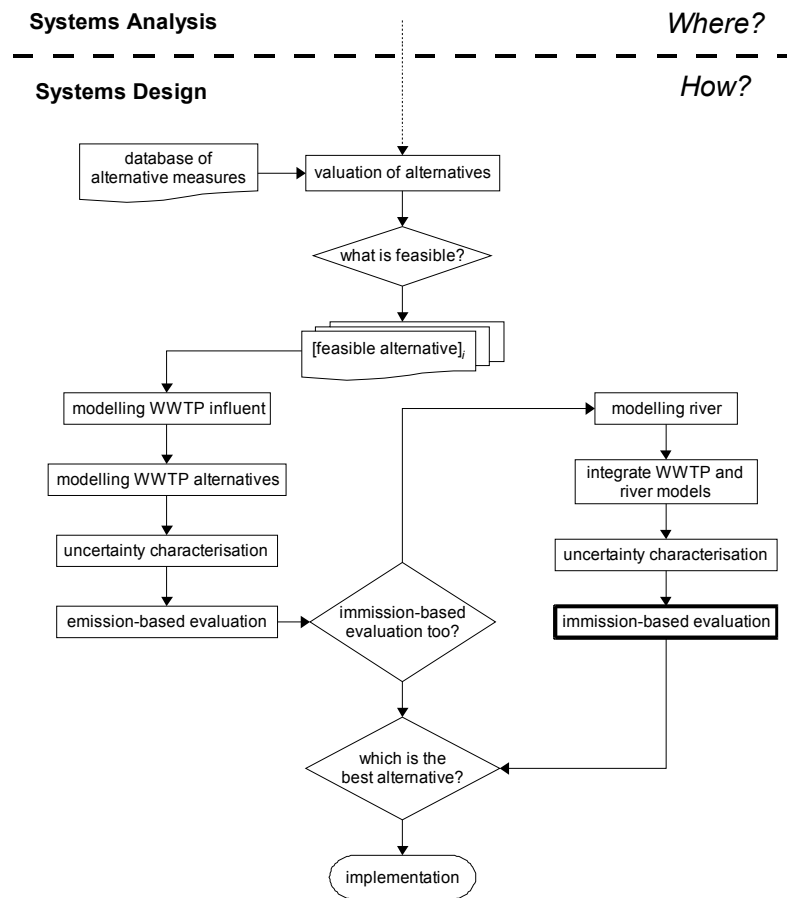

Figure 160: Immission-based evaluation within Systems Design.

## 13.2 Results

In this work, three WWTP upgrade options were compared:

- U0: no upgrade;
- U2: extension by 33% of both activated sludge and settling volumes;
- U13: increase of maximum treated flow from 2.5 DWF to 5 DWF, increase of flow going to treatment and to storm tank from 5 DWF to 10 DWF and double the maximum recirculation and return sludge pumping capacity.

Figure 78 shows the model layout in WEST. An example of concentration time series with uncertainty information is provided in Figure 161 for  $\text{NH}_4$  and in Figure 162 for DO.

As can be noted, 5.000m after the WWTP effluent there is almost no uncertainty indicated, since the processes in the river are strongly influencing the results and in this study no uncertainty is introduced for the parameters in the river model. This was done to simplify the evaluation procedure, but uncertainty in the river model parameters should be included in practical applications.

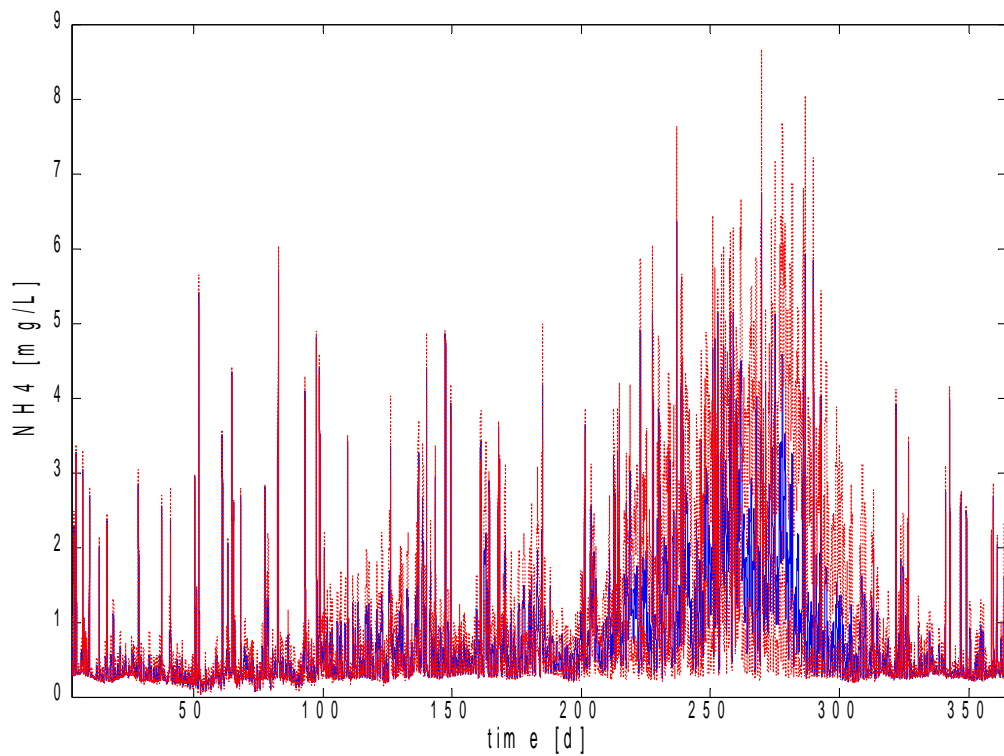

Figure 161:  $\text{NH}_4$  concentration from July to June in the first tank of the river model (1.000m downstream the WWTP effluent) with U0; 50<sup>th</sup> percentile (solid line) and 5<sup>th</sup> and 95<sup>th</sup> percentiles (dotted line).

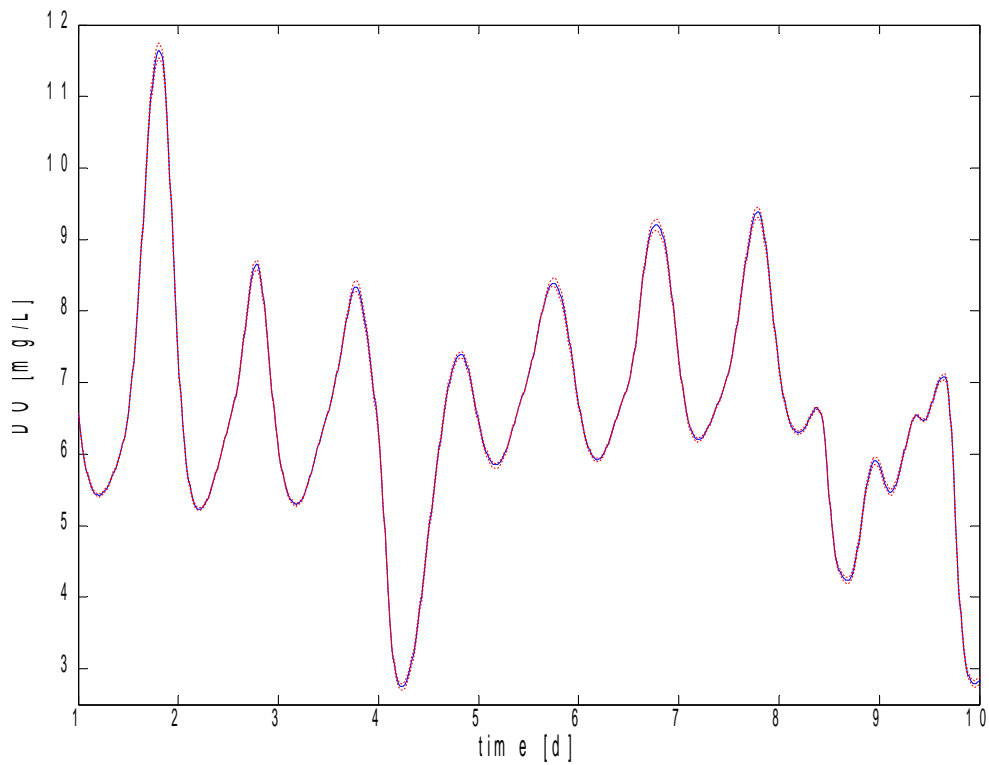

Figure 162: DO concentration for ten days in October in the last tank of the model (5.000m downstream the WWTP effluent) with U0; 50<sup>th</sup> percentile (solid line) and 5<sup>th</sup> and 95<sup>th</sup> percentiles (dotted line).

First of all, a basic emission-based evaluation is performed. From Figure 163 it can be deduced that U2 implies higher costs (in particular capital cost) and that U13 has lower costs than U0, for both climates. Figure 164 shows that this can be due to the associated aeration energy costs. Further analysis revealed that the higher hydraulic load to U13 leads to a lower MLSS concentration in the aerated tanks – due to larger TSS effluent in wet weather – which entailed the lower aeration requirements and also to lower sludge production.

On the other hand, the EQI (pollutant loads) of U13 is not far from the one of U0 (in Mediterranean climate it is even slightly better) and both are around 20% worse than U2 in Continental climate and 10% worse in Mediterranean climate.

The better  $\text{NH}_4$  effluent concentration of U13 compared to U0 is probably due to the increased maximum pumping capacity, which keeps  $\text{NH}_4$  longer in the system in wet weather allowing more nitrification. The larger dilution in U13 also plays a role in this result, since the extra flows allowed to the treatment line and to the storm tank occur only in wet weather flow.

No sludge losses happen in U13 because of the dimensioning of the secondary settler. Note that settling problems (e.g. bulking or insufficient hydraulic capacity) are not the topic of this study, therefore a good SVI was assumed in all simulations (100mL/g).

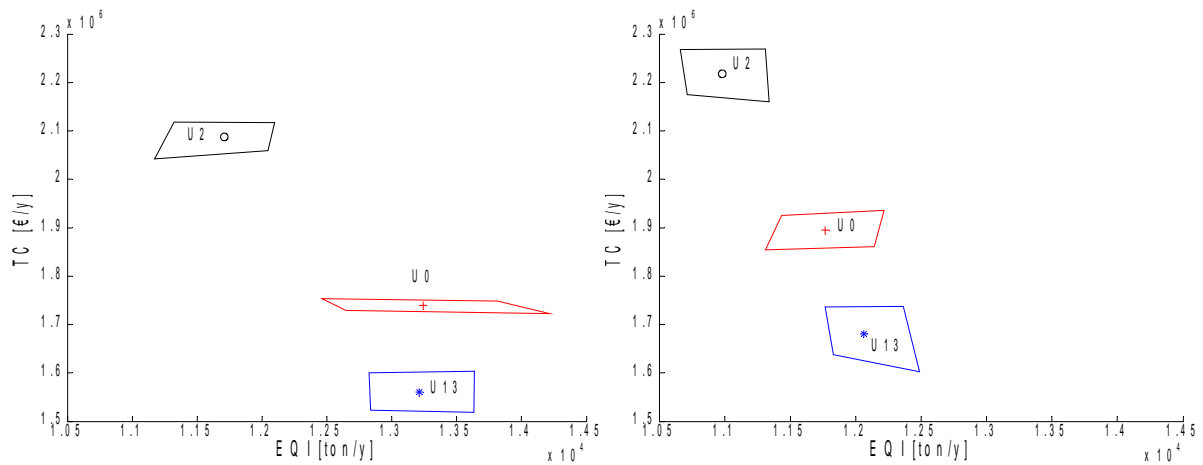

Figure 163: Yearly average EQI and TC for LLAS 300,000PE upgrades in Continental (left) and Mediterranean (right) climates.

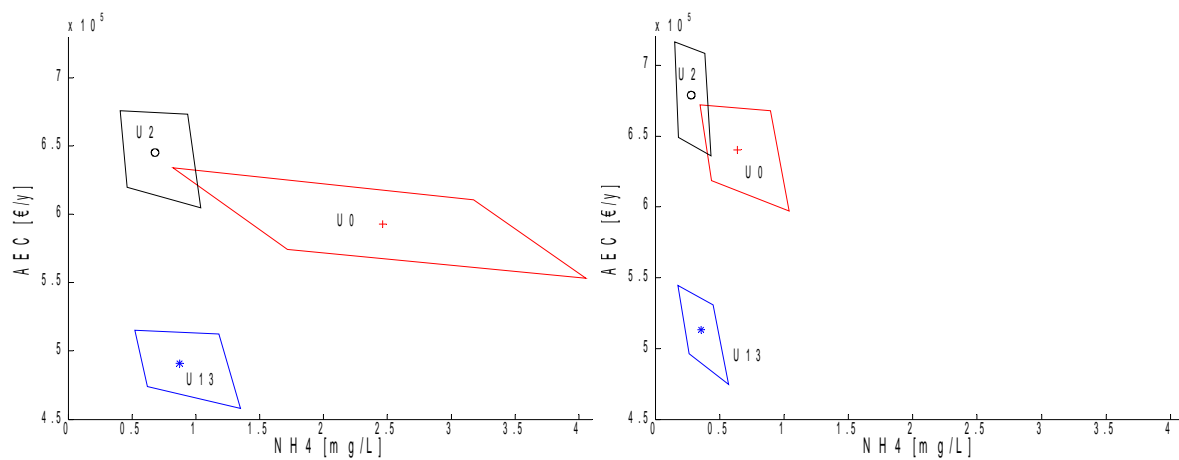

Figure 164: Yearly average  $\text{NH}_4$  and AEC for LLAS 300,000PE upgrades in Continental (left) and Mediterranean (right) climates.

For to the immission-based evaluation, looking at the variables averages in the river (Figure 165 and Figure 166) one can notice a clearly better situation with U13. For  $\text{NH}_4$ , the cold winter in the Continental climate penalises U0 for its difficult nitrification, while in the Mediterranean climate such difference is not very significant. U13 achieves lower  $\text{NH}_4$  in the river than U2, while  $\text{NO}_3$  is lower with U2 but only very slightly. Also for DO and COD the pattern is similar, with U13 performing slightly better than U2 and with U0 clearly showing its deficiencies.

The reliability of the process looks better for U2 compared to U13 and this is confirmed by Figure 167. The higher RRI for the four considered pollutants in the river is caused by the larger aerated volumes of U2, which give more stability to the process. In the Mediterranean climate the differences between the three options are less pronounced due to the improved and more stable nitrification.

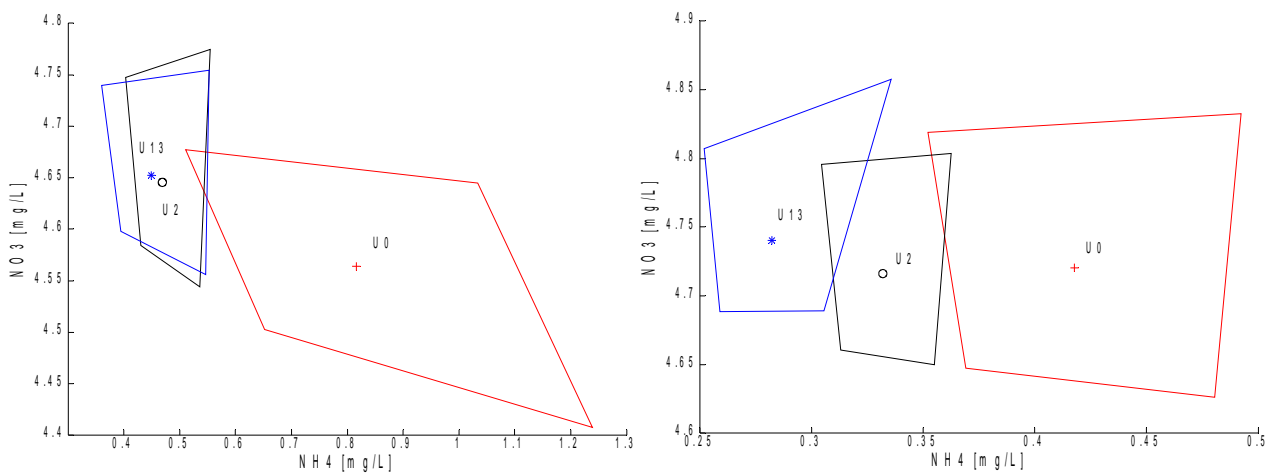

Figure 165: Yearly average  $\text{NH}_4$  and  $\text{NO}_3$  in the river 1.000m downstream the WWTP effluent for LLAS 300,000PE upgrades in Continental (left) and Mediterranean (right) climates.

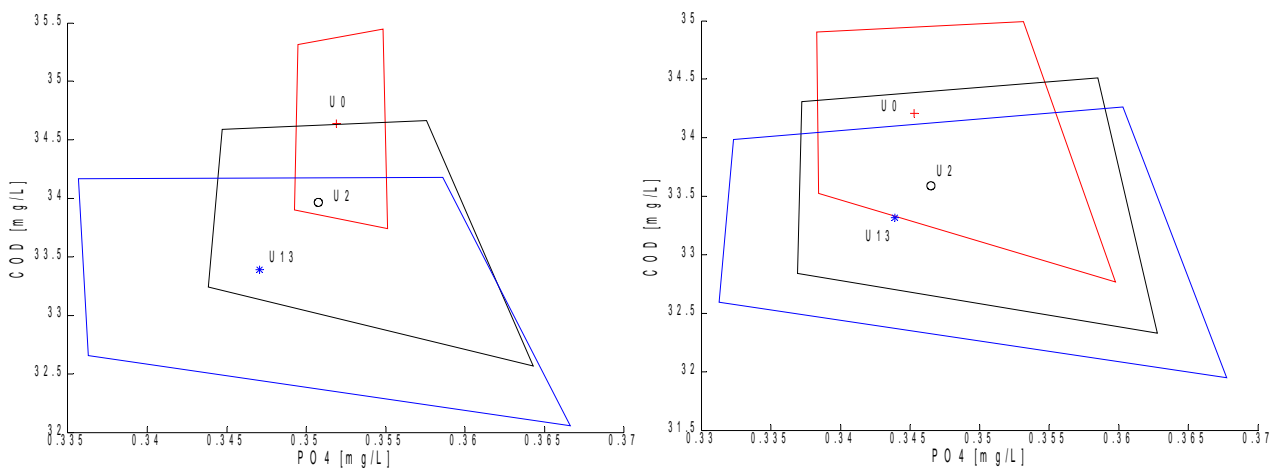

Figure 166: Yearly average  $\text{PO}_4$  and COD in the river 1.000m downstream the WWTP effluent for LLAS 300,000PE upgrades in Continental (left) and Mediterranean (right) climates.

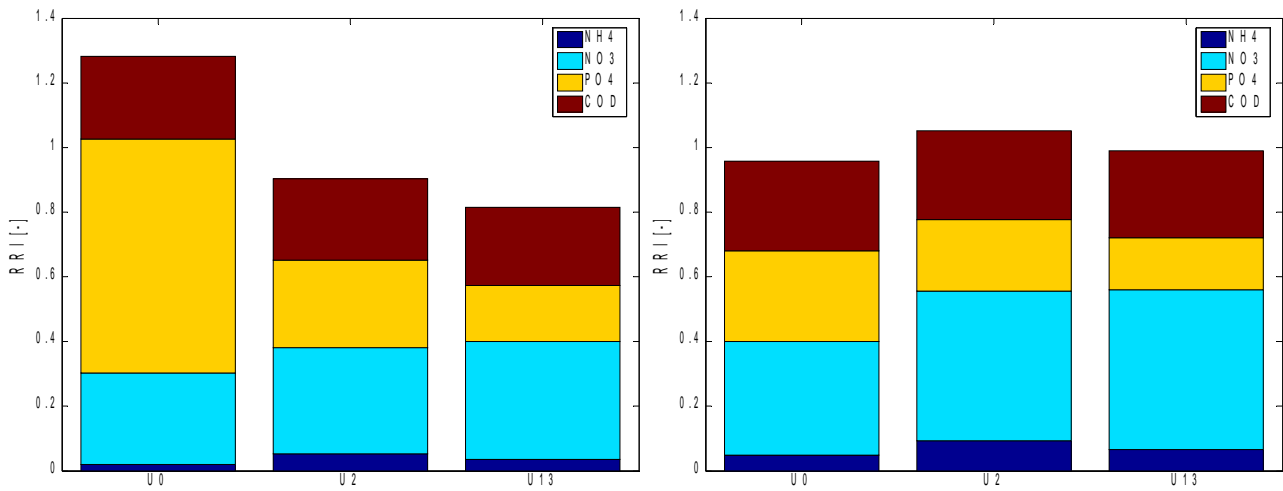

Figure 167: RRI of NH<sub>4</sub>, NO<sub>3</sub>, PO<sub>4</sub> and COD in the river 1.000m downstream the WWTP effluent for LLAS 300,000PE upgrades in Continental (left) and Mediterranean (right) climates.

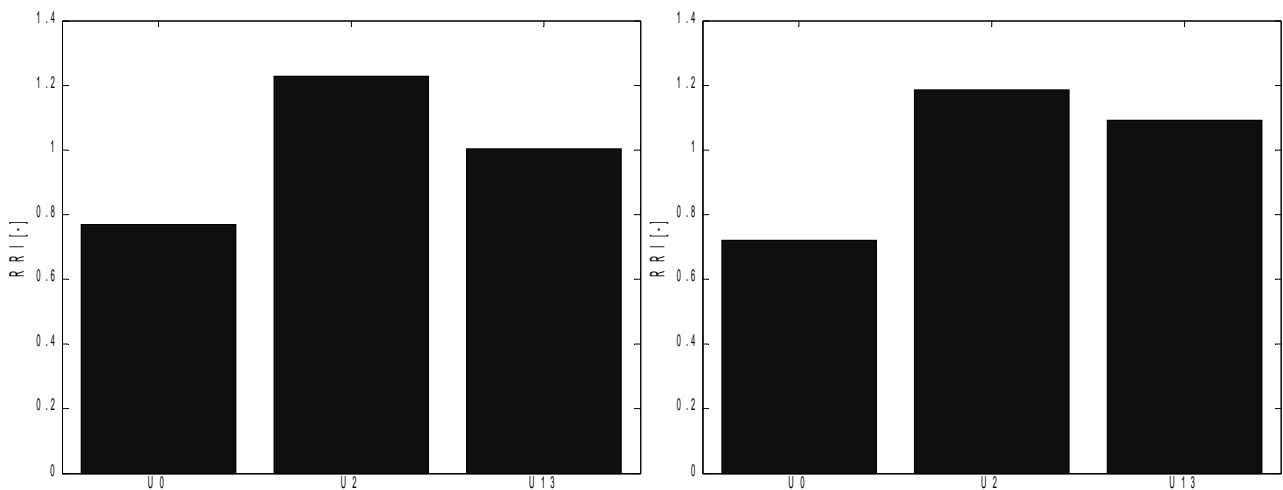

Figure 168: RRI DO in the river 5.000m downstream the WWTP effluent for LLAS 300,000PE upgrades in Continental (left) and Mediterranean (right) climates.

Concerning the exceedance periods for NH<sub>4</sub>, NO<sub>3</sub>, DO and COD (Figure 169 to Figure 172), they all show the same behaviour, with U0 clearly having larger exceedance periods than U2 and U13 which perform very similarly in both climates. In general, a slightly larger variance can be observed for U13 due to the smaller process volumes which give less stability than for U2.

With regard to exceedance periods for PO<sub>4</sub> (Figure 173), it can be noted that U0 and U2 perform very similarly since they are equally loaded and PO<sub>4</sub> removal is a controlled process of chemical precipitation. U13 improves significantly PO<sub>4</sub> values in the river because more of the wet weather influent is treated and less is by-passed to the storm-tank and to the CSO. Since the removal is controlled with the same set-point the U13 effluent concentration is the same as for U0 and U2, leading to an overall reduction of PO<sub>4</sub> load released in the river.

Another peculiar aspect of the PO<sub>4</sub> exceedance periods is its large variability at the higher end of



the concentrations. This fact can be explained by looking at Figure 174, where the average MLSS in the activated sludge tank and TP in the effluent of the plant are plotted for all simulations of U2 (left) and U13 (right) in Continental climate. For U13 the average TP effluents are generally lower than for U2, but with MLSS lower than a certain value some instability is introduced in the process and several average effluents show higher TP concentrations.

The outcome of the immission-based evaluation is that the water quality resulting from the implementation of U13 is slightly better than the one resulting from U2, at much lower costs. Limiting the analysis to the effluent quality would have led to the exclusion of U13, which had an EQI comparable to the one of U0 and significantly worse than U2.

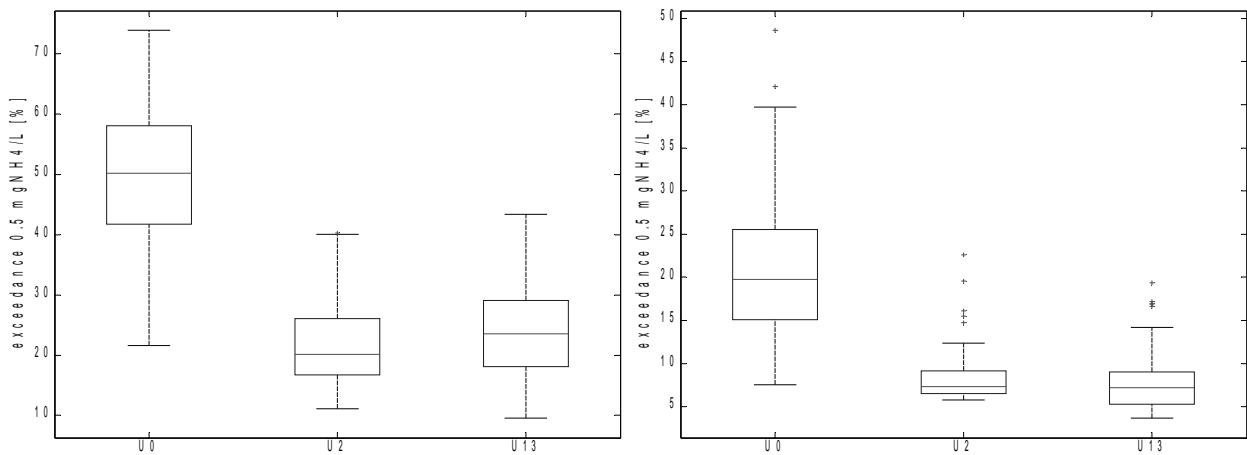

Figure 169: Exceedance of  $0.5\text{mgNH}_4/\text{l}$  in the river 1.000m downstream the WWTP effluent for LLAS 300,000PE upgrades in Continental (left) and Mediterranean (right) climates.

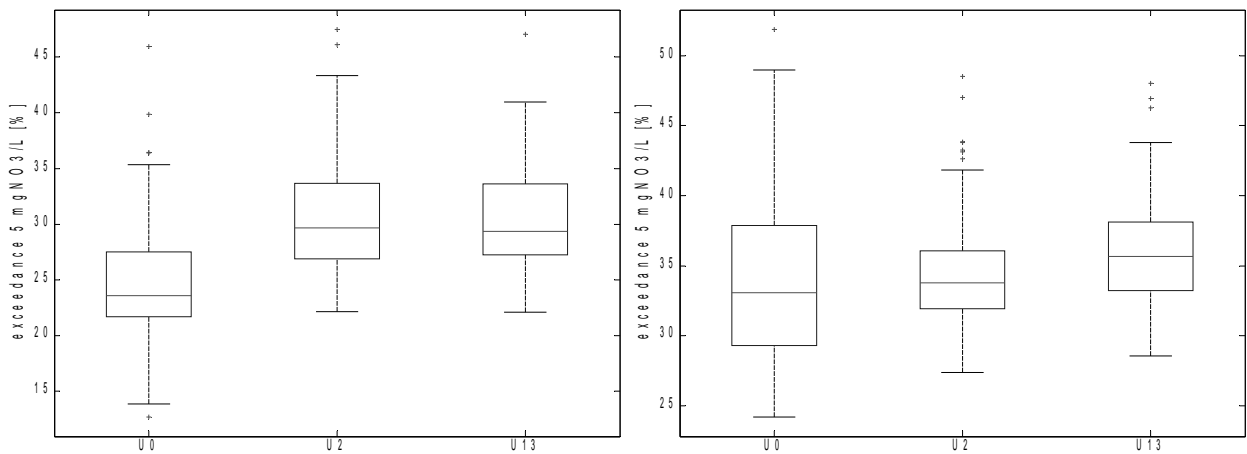

Figure 170: Exceedance of  $5\text{mgNO}_3/\text{l}$  in the river 1.000m downstream the WWTP effluent for LLAS 300,000PE upgrades in Continental (left) and Mediterranean (right) climates.

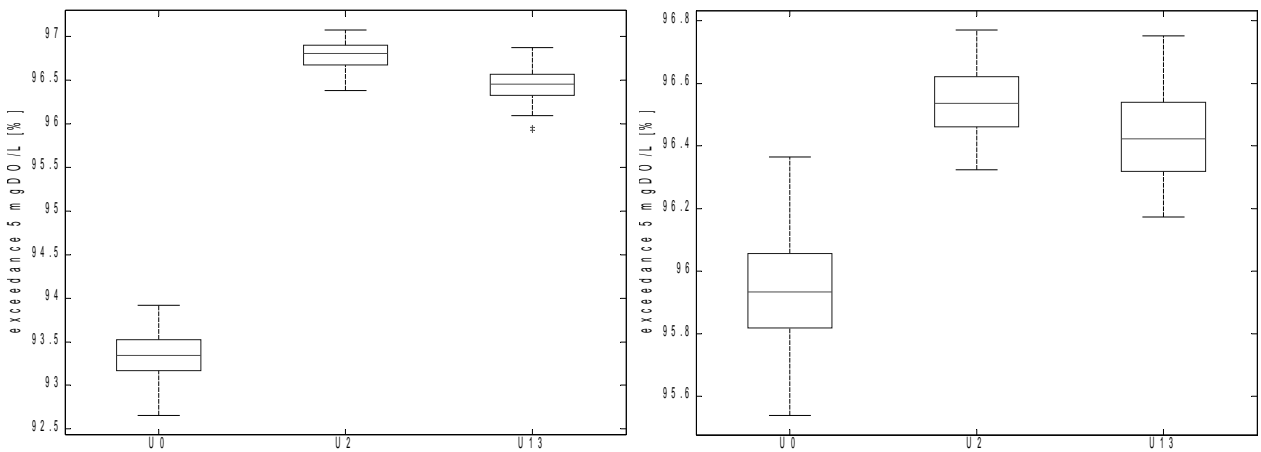

Figure 171: Exceedance of 5mgDO/l in the river 5.000m downstream the WWTP effluent for LLAS 300,000PE upgrades in Continental (left) and Mediterranean (right) climates.

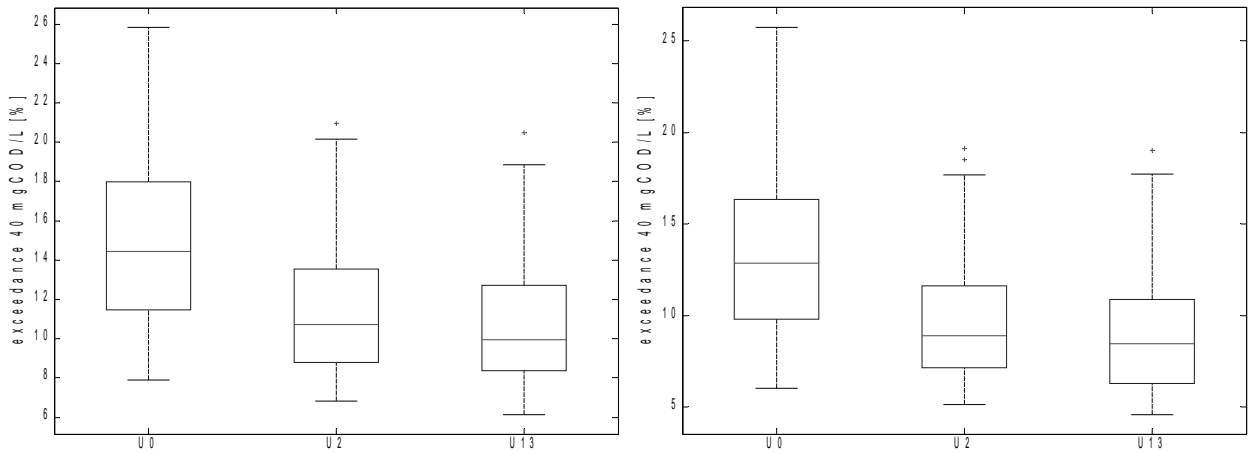

Figure 172: Exceedance of 40mgCOD/l in the river 1.000m downstream the WWTP effluent for LLAS 300,000PE upgrades in Continental (left) and Mediterranean (right) climates.

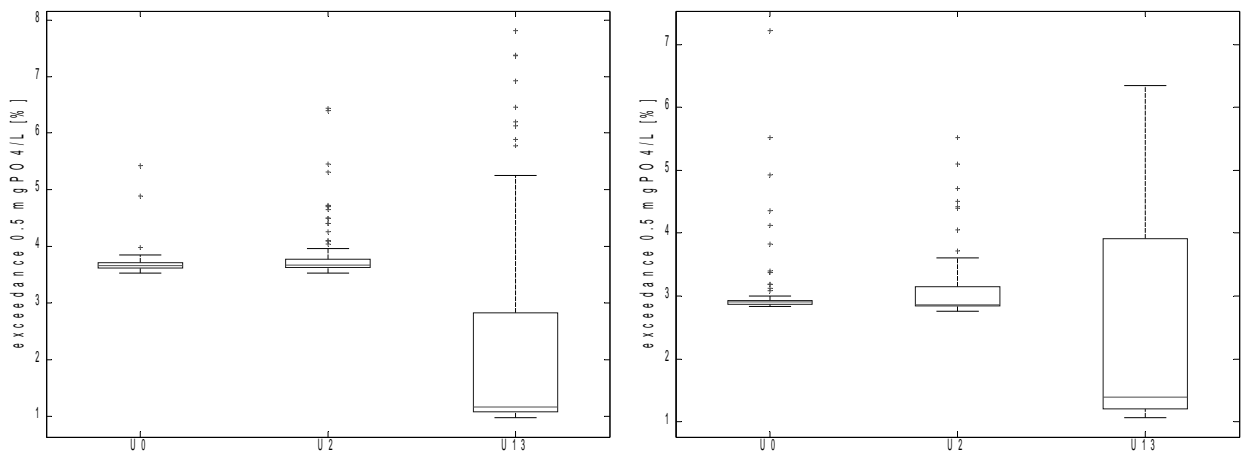
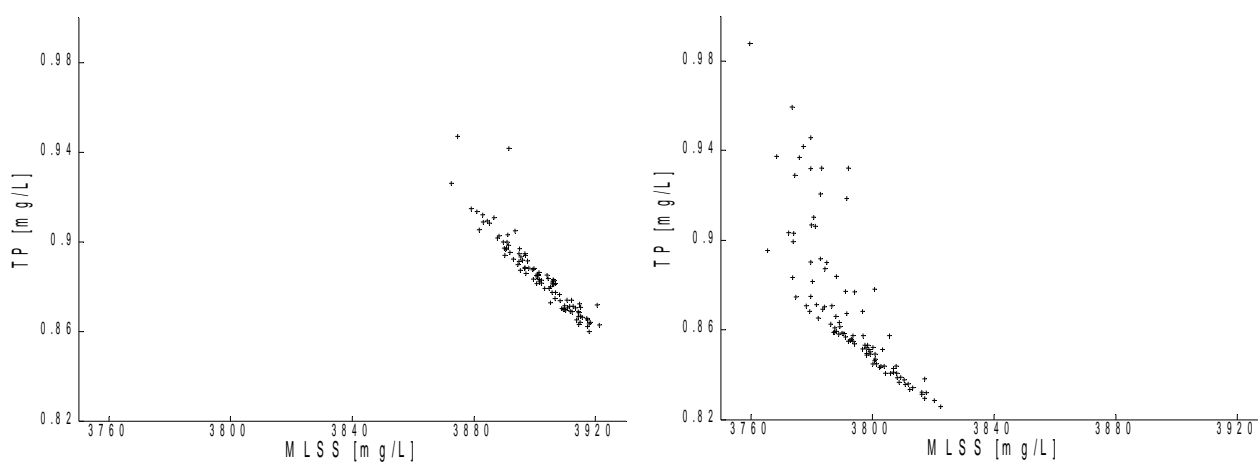

Figure 173: Exceedance of 0.5mgPO<sub>4</sub>/l in the river 1.000m downstream the WWTP effluent for LLAS 300,000PE upgrades in Continental (left) and Mediterranean (right) climates.



*Figure 174: MLSS in the tanks and TP in the effluent for LLAS 300,000PE in Continental climate for U0 (left) and U13 (right).*

### 13.3 Conclusions

Combining the information coming from the emission- and the immission-based evaluations performed in this chapter, it can be concluded that in a water quality based regulation context, the assessment of effluent quality is not sufficient to take appropriate and informed decisions. From the immission-based evaluation the conclusion was that an upgrade which does not require construction of new volumes (more wastewater sent to the treatment line and less to the by-pass) performs as well as an expensive upgrade requiring construction (extension of activated sludge tanks). This kind of information is of great value in water quality based legislative context as the WFD, allowing to adopt solutions which are better for both the environmental and the economic aspects.



## GENERAL CONCLUSIONS

The introduction of the EU Water Framework Directive requires compliance with effluent quality standards and with receiving water quality standards. This increased complexity implies that the evaluation of the impact of measures on the water quality should be evaluated with appropriate tools, both from the methodological point of view, and by making the developed methodology applicable in practice by means of adequate software tools.

Urban wastewater systems (UWWs) are crucial components of river basins, since they usually contribute substantially to the pollution loads affecting the receiving water body, and also have more flexibility in their operation and management than other subsystems as agriculture.

In this dissertation several aspects of systems analysis, modelling and decision aid for the support of the WFD implementation at the urban scale were presented and discussed. This chapter condenses the major conclusions that can be drawn from this study.

A methodology was presented to help taking decisions on where and how to improve the urban wastewater system. It is suggested that the first question (“where?”) is answered by performing a systems analysis of the catchment, the sewer, the WWTP and the urban river stretch, as a whole system. The second question (“how?”) is suggested to be answered by carrying out an appropriate systems design (from the selection of correction measures to the design and dimensioning of the intervention).

### Systems analysis

For systems analysis, the two proposed tools – substance flow analysis and the evaluation of indicators – were illustrated by means of a case study on the river Nete, in Flanders.

Substance flow analysis (SFA), combined with mass balances, proved to be a useful tool to fulfil the Water Framework Directive’s requirement to reveal, in a quantitative way, both the major pressures and impacts on the receiving water, pinpointing information gaps. The river basin system including fluxes running through such a system was described and boundaries and interfaces were outlined. Through SFA, critical points in the system could be identified and could serve as indication for further, more detailed analysis. The main pressures on the investigated river basin are – especially for BOD and COD – untreated wastewater from households, while agriculture is the main stressor for total nitrogen and all the stressors (i.e. households, industries, WWTPs, agriculture) have a comparable importance concerning total phosphorus.

The study showed that it is difficult to obtain reliable substance flows for heavy metals (in this case, zinc) due to the fact that a large fraction is discharged with stormwater, for which there are usually no water quality measurements.

The availability and accuracy of the data play a crucial role. This aspect was clearly illustrated by the large uncertainties for the flows calculated in the SFA, which was assessed on the basis of the data origin and quality.

The average economic and environmental situation of the studied catchment (the Nete) is within the upper range of performance compared to figures reported in the literature as well as to other Flemish urban catchments.

The study on the Nete river basin indicates that the major factor of operational inefficiency of the urban wastewater collection and treatment systems is the infiltration of parasitic water entering the sewer network. Parasitic water lead to considerable additional treatment and pumping costs in winter, along with environmental risks related to exfiltration (and therefore groundwater contamination) in summer. In this area the sewerage networks – as they have often historically grown – have mostly a high drainage component. Whether or not possible rehabilitation processes are deemed to be effective depends on site-specific conditions such as the status of pre-existing infrastructure, institutional arrangements about planning and financing of the urban water cycle and the mindset of the involved parties.

The study also highlighted the importance of the spatial scale selection. Values of some indicators at individual urban catchment scale showed a large variance (e.g. mass balances, CSOs) but the average value for the whole river basin is well in the range of values found in literature. For large regions like a river basin, results are likely to fall in the range of results found in similar studies, but with small areas local factors and uncertainties play a major role.

### **Systems design methodology**

Concerning systems design, the methodology – developed in detail and illustrated for the particular case of WWTP design and upgrade – to derive a comprehensive model of the system that forms the basis of the probabilistic assessment is introduced. First of all, long time influent time series were generated, then the alternative process configurations were designed and implemented in WEST (the modelling and simulation software), the uncertainties were characterised and finally, after performing Monte Carlo simulations, the alternatives were compared and evaluated with the emission-based approach. To perform the immission-based evaluation as well, a river model was implemented and linked to the WWTP model by means of a specifically developed model connector, the uncertainties were characterised and the results of the MC simulations were used for the comparison.

As for the influent time series generation, it was shown that phenomenological models of limited complexity can be used to build WWTP influent flow rate and pollutant concentration scenarios, without the need of complex deterministic models of the urban drainage system.

Among the work done for integrated modelling of urban wastewater systems, particular relevance is given to the connector between ASM2d and RWQM1. It is an example to show the approach developed to translate state variables from one model to another. Inherent features of this connector are its closed mass and elemental balances. The COD fractions of ASM2d have been split over the COD fractions of RWQM1, while compensation terms were used to close elemental balances. Also the different environmental conditions in the systems (activated sludge tanks and river) were taken into account to correct for inactivation of organisms when changing from one system to another. An evaluation of the influence of several connector and models parameters on connector compensation terms and outputs was performed, showing that great importance lies in the elemental composition of the state variables.

The main advantage of the proposed method is that it is transparent and flexible, which means that the appropriate treatment level can be found as a function of the local effluent limits – in terms of averages, percentiles of exceedance frequency on composite samples, etc. –, of the local water quality standards, and of the associated local treatment costs.

### **Results for design/upgrade**

The proposed benchmarking methodology shows promising results for the systematic comparison of urban wastewater treatment measures. As for the emission-based WWTP dimensioning analysis, it can be concluded that building activated sludge volumes smaller than the ones traditionally calculated by applying design guidelines leads to considerable total cost reductions, while it entails only a small increase in the risk of not complying with emission standards. When comparing ten different process configurations, alternating systems show the best cost-benefit performance while high loaded systems show the lowest. The comparison results are dependent on the boundary conditions and on the cost data used for the study, but the methodology is general. The comparison of eleven WWTP upgrade options put in evidence the advantages and disadvantages of upgrades that require construction of volumes and real-time control upgrades, the first generally providing more process stability at high cost and the second delivering good performance improvement at low cost but with more risk of compliance failure.

An important conclusion is that WWTPs designed with ATV guidelines can accept almost double the design load and still comply with the yearly average limits of the EU Urban wastewater Directive. However, it is not suggested that ATV guidelines should be changed, but that they are specifically developed to fulfil specific (German) effluent quality regulations. Still, the application of ATV design guidelines to very different environmental, economic and legislative conditions can lead to inefficient solutions.

The immission-based evaluation of three upgrade options clearly revealed its potential in water quality based regulations, indicating as more beneficial for the receiving water an option which would have been discarded by just looking at the WWTP emission quality.

### **Software tools**

WEST (and its new development Tornado) is a flexible and powerful system for modelling biological processes, as well as for defining and executing so-called virtual experiments (VEs) on the basis of these models, like MC simulation. Since the complexity of VEs (probabilistic design, optimal experimental design, global sensitivity analysis, scenario analysis, etc.) and the models the VEs are applied to are constantly increasing, a framework for the distributed execution of VEs on a potentially heterogeneous pool of work nodes has been implemented. This framework was named Typhoon and was designed for stability, expandability, performance, platform-independence and ease of use. With the use of the innovative tools introduced in this work it was possible to generate the simulation output data to compare 10 plant layouts on their benefit/cost/risk in no longer than 2 days compared to an estimated 120 days without these developments.

### **Take-away message**

This dissertation proved that the availability of well-accepted models, uncertainty characterisation and propagation techniques and sufficient computational power should move the design practice from conventional procedures suited for a relatively stiff context as imposed by emission limits, to more advanced, transparent and cost-effective procedures appropriate to cope

## General Conclusions

---

with the flexibility and complexity introduced by integrated water management approaches like the WFD.



## PERSPECTIVES

### A personal outlook

It is of paramount importance to organise the collection of data in river basins, not only to assess the compliance of single subsystems with current legislation, but also to evaluate the interactions between the subsystems and to facilitate the modelling of the whole system. A considerable gap was noted in the availability of data on diffuse pollution sources like agriculture and stormwater discharges. More attention towards those contributions would allow to better assess the relative importance on pressures on the receiving water and therefore to more adequately prioritise interventions. The effect of the existence of information gaps is that an evaluation of the uncertainties affecting the results should become a requirement of the studies carried out with such data. Anyway, the presence of uncertainty should not become an excuse not to act, and just wait to be perfectly sure that a system is not performing well. Further data acquisition can recalibrate the intervention policy (adaptive management).

The ability of simple models – like the phenomenological catchment and sewer model presented in this dissertation – to produce realistic dynamic influent time series opens perspectives for applications within simulation-based evaluation of WWTP design, upgrade and control scenarios, (like in this study) or systematic assessment of control options, as show the activities of the IWA Benchmarking Task Group (Rosen *et al.*, 2004; Jeppsson *et al.*, 2006).

Going a step further, some kind of life cycle analysis for WWTPs (or even UWWs) could be performed. It would require the simulation of the whole expected life time of the plant, from start-up to decommissioning, including all influencing events like sensor and equipment failures, other random events in operation, longer term dynamics like population and industry increase or decrease, forecasts on prices and technological advancements, etc.

It would also be interesting to further test and develop the methodology – especially the immission-based evaluation with integrated modelling – for measures in other parts of the river basin system (e.g. rehabilitation or construction of sewer pipes, real-time control of the sewer system, measures to control diffuse pollution of urban and agricultural origin, etc.) and for the fate of other substances, like the priority pollutants recently listed in the context of the WFD.

From a practical point of view, the presence in complex dynamic modelling software of simple steady-state models for initial dimensioning of structures – also based on existing design guidelines such as ATV – would be a warmly welcomed feature. Gillot *et al.* (1999) started to develop a methodology to use dynamic models to predict operating costs for the implementation of RTC options and steady-state simulations to optimise the design of WWTPs and calculate capital costs.

Additional features would improve the performance of the tools, like intelligent job scheduling

for Typhoon (Chtepen *et al.*, 2006), or automatic model selection and calibration and automatic numerical solver selection and setting, which in function of the model used and of the desired accuracy, selects the most appropriate solver and associated settings (e.g. integration time step) to achieve the lowest simulation time possible (Claeys *et al.*, 2006d).

The uncertainty characterisation phase presents several interesting aspects which would require further efforts. The first point is the definition of the probability density functions for the model parameters, since very little information is available in literature at least in the domain of this study. A related aspect is the introduction of correlation between parameters (Rousseau *et al.*, 2001) and how to characterise it in the sampling step of MC simulation. Another interesting issue is that in this study 100 samples were judged to be sufficient for convergence of a specific variable, but further investigation on the sampling method and on procedures to systematically and generally determine the minimum but sufficient number of samples in MC simulation to adequately perform the uncertainty propagation would be desirable; a proposal could be to provide a tolerance for the convergence of certain quantities, like the percentiles, with different values in case of the median or of the tails of the distribution.

A development which would allow to better consider the uncertainties in many aspects of the proposed methodology, would be to incorporate the illustrated steps in a Bayesian network (Ames *et al.*, 2005). This would allow the inclusion and elaboration of many types of information that can be acquired or generated in the planning study and would facilitate and make the decisions-making process more transparent.

The uncertainty propagation approach might also be improved. Basically, MC simulation as it was applied in this work does not allow to distinguish between variability (randomness, i.e. random variables observed with total precision) and uncertainty (partial lack of knowledge, i.e. deterministic parameters whose value is imprecisely known). The former can actually be modelled by means of probability distributions, while the latter requires either second-order MC simulation or different instruments (like e.g. fuzzy sets) as suggested by the imprecise probabilities theory (Walley, 1991) and not by just assuming a uniform distribution. As a consequence, the propagation of uncertainty in the context of imprecise probabilities would require additional efforts (Baudrit *et al.*, 2006).

## REFERENCES

- Aalderink, R. H., Klaver, N. and Noorman, R. (1995). DUFLOW V2.0 Micro-Computer package for the simulation of 1-dimensional flow and water quality in a network of open water courses. *Water Quality Modelling*. In: Proceedings of the International Conference on Water Quality Modelling, Orlando, USA, 2-5 April 1995.
- Ahlman, S. (2006). Modelling of substance flows in urban drainage systems. PhD thesis, Chalmers University of Technology, Göteborg, Sweden.
- Alex, J., Risholt, L. P. and Schilling, W. (1999). Integrated modeling system for simulation and optimization of wastewater systems. In: Proceedings of 8th International Conference on Urban Storm Drainage, Sydney, Australia, 30 August - 03 September 1999.
- Ames, D.P., Neilson, B.T., Stevens, D.K. and Lall, U. (2005). Using Bayesian networks to model watershed management decisions: an East Canyon Creek case study. *Journal of Hydroinformatics* 7(4), 267-282.
- ANPA (2001). Guida alla progettazione dei sistemi di collettamento e depurazione delle acque reflue urbane. Agenzia Nazionale per la Protezione dell'Ambiente.
- ATV (1995). *Betriebstechnik, Kosten und Rechtsgrundlagen der Abwasserreinigung*, Ernst & Sohn Verlag, Weinheim, Germany.
- ATV (2000). Standard ATV-DVWK-A 131E. Dimensioning of Single-Stage Activated Sludge Plants.
- Azar, C., Holmberg, J. and Lindgren, K. (1996). Socio-ecological indicators for sustainability. *Ecological Economics* (18), 89-112.
- Balkema, A.J., Preisig, H.A., Otterpohl, R. and Lambert, F.J.D. (2002). Indicators for the sustainability assessment of wastewater treatment systems. *Urban Water* (4), 153-161.
- Balmér, P. (2000). Operation costs and consumption of resources at Nordic nutrient removal plants. *Water Science and Technology* 41(9), 273-279.
- Baudrit, C., Couso, I. and Dubois, D. (2006). Joint propagation of probability and possibility in risk analysis: Towards a formal framework. *International Journal of Approximate Reasoning* (in press).
- Battistoni, P., Pavan, P., Prisciandaro, M. and Cecchi, F. (2000). Struvite crystallization: a feasible and reliable way to fix phosphorus in anaerobic supernatants. *Water Research* (34)11, 3033-3041.
- Belevi, H. (2002). Material flow analysis as a strategic planning tool for regional wastewater and

## References

---

- solid waste management. In: Proceedings of the workshop "Globale Zukunft: Kreislaufwirtschaftskonzepte im kommunalen Abwasser- und Fäkalienmanagement". Munich, Germany, 13-15 May 2002.
- Benedetti, L., Meirlaen, J., Sforzi, F., Facchi, A., Gandolfi, C. and Vanrolleghem, P. A. (2004a). Dynamic integrated modelling: A case study on the river Lambro. In: Proceedings of the NOVATECH 2004, Lyon, France, 6-10 June 2004.
- Benedetti, L., Meirlaen, J. and Vanrolleghem, P.A. (2004b). Model connectors for integrated simulations of urban wastewater systems. In: Sewer Networks and Processes within Urban Water Systems. Bertrand-Krajewski, J.-L., Almeida, M., Matos, J. and Abdul-Talib, S. (eds), pp. 13-21, IWA Publishing, London, UK.
- Benedetti, L., Krebs, P. and Vanrolleghem, P.A. (2004c). Cost-effective development of urban wastewater systems for Water Framework Directive compliance - the CD4WC EU project. In: Proceedings of WaPUG - IMUG International Conference, London, UK, 17 September 2004.
- Benedetti, L., Blumensaat, F., Bönisch, G., Dirckx, G., Jardin, N., Krebs, P. and Vanrolleghem, P.A. (2005). Systems Analysis of urban wastewater systems - two systematic approaches to analyse a complex system. *Water Science and Technology* 52(12), 171-179.
- Benedetti, L., Bixio, D., Claeys, F. and Vanrolleghem, P.A. (2006a). Tools to support a model-based methodology for benefit/cost/risk analysis of wastewater treatment systems, In: Proceedings of iEMSs 2006, Burlington, VT, USA, 10-13 July 2006.
- Benedetti, L., Bixio, D. and Vanrolleghem, P.A. (2006b). Assessment of WWTP design and upgrade options: balancing costs and risks of standards' exceedance. *Water Science and Technology* 54(6-7), 371-378.
- Benedetti, L., Dirckx, G., Bixio, D., Thoeye, C. and Vanrolleghem, P.A. (2006c). Substance flow analysis of the wastewater collection and treatment systems. *Urban Water Journal* 3(1), 33-42.
- Benedetti, L., Dirckx, G., Bixio, D., Thoeye, C. and Vanrolleghem, P.A. (2006d). Environmental and economic performance assessment of the integrated urban wastewater system. *Journal of Environmental Management* (resubmitted).
- Benedetti, L., Bixio, D. and Vanrolleghem, P.A. (2006e). Benchmarking of WWTP design by assessing costs, effluent quality and process variability. *Water Science and Technology* 54(10), 95-102.
- Bixio, D., Carette, R. and Thoeye, C. (2002a). Two years of full-scale storm operation experience. *Water Science and Technology* 46(6-7), 167-172.
- Bixio, D., Parmentier, G., Rousseau, D., Verdonck, F., Meirlaen, J., Vanrolleghem, P.A. and Thoeye, C. (2002b). A quantitative risk analysis tool for design/simulation of wastewater treatment plants. *Water Science and Technology* 46(4-5), 301-307.
- Bixio, D., Thoeye, C. and De Gueldre, G. (2004). Biological solution to stormwater? *Water Science and Technology* 50(7), 171-177.
- Blumensaat, F., Tränckner, J. and Krebs, P. (2006a). Assessment of measures for the optimisation of integrated urban wastewater systems using a combined evaluation approach. In: Proceedings of 7<sup>th</sup>UDM & 4<sup>th</sup>WSUD, Melbourne, Australia, 4-6 April 2006.
- Blumensaat, F., Tränckner, J., Koegst, T., Hoef, S. and Krebs, P. (2006b). Systematic optimisation of urban wastewater systems – the Platterberg case. In: Proceedings of CD4WC dissemination

- workshop, Dresden, Germany, 3-4 July 2006.
- Bode, H. and Grünebaum, T. (2000). The cost of municipal sewage treatment - structure, origin, minimization - methods of fair cost comparison and allocation. *Water Science and Technology* 41(9), 289-298.
- Bode, H. and Lemmel, P. (2001). International product cost comparison in the field of water management. *Water Science and Technology* 44(2-3), 85-93.
- Bohn, T. (1993). *Wirtschaftlichkeit und Kostenplanung von kommunalen Abwasserreinigungsanlagen*, Media-Partner-Verlagsagentur Gütersloh, Germany.
- Bohnke, B. (1989). Bemessung der Stickstoffelimination in der Abwasse. *Korrespondenz Abwasser*, 9, 1047-1061.
- Bowie, G. L., Mills, W. B., Porcella, D. B., Campbell, C. L., Pagenkopt, J. R., Rupp, G. L., Johnson, K. M., Chan, P. W. H. and Gherini, S. A. (1985). *Rates, Constants and Kinetics Formulations in Surface Water Quality Modeling*. 2nd Ed., US EPA, Athens, GA, USA.
- Brouwer, H., Bloemen, M., Klapwijk, B. and Spanjers, H. (1998). Feedforward control of nitrification by manipulating the aerobic volume in activated sludge plants. *Water Science and Technology*, 38(3), pp. 245-254.
- Brown, L. C. and Barnwell, T. O. (1987). *The enhanced stream water quality models, QUAL2E and QUAL2E-UNCAS: Documentation and User Manual*. US EPA, Athens, GA, USA.
- Brunner, N. and Starkl, M. (2004). Decision aid systems for evaluating sustainability: a critical survey. *Environmental Impact Assessment Review* 24, 441-469.
- Butler, D. and Davies, J. W. (2000). *Urban Drainage*, E & FN Spon, London, UK.
- Carlsson, B. and Milocco, R.H. (2001). A simple strategy for controlling the nitrate concentration in an activated sludge process using external carbon flow rate. *Latin American Applied Research* 31(2), 115-120.
- CD4WC (2004). Identification of interactions in present full-scale systems. Project deliverable D1.2.
- CEC (1991). Council Directive 91/271/EEC of 21 May 1991 concerning urban wastewater treatment.
- CEC (2000). Directive 2000/60/EC of the European Parliament and of the Council establishing a framework for the Community action in the field of water policy.
- Chow, V. T., Maidment, D. R. and Mays, L. W. (1988). *Applied Hydrology*, McGraw-Hill, New York, USA.
- Chtepen, M. and Claeys, F.H.A. and Dhoedt, B. and De Turck, F. and Demeester, P. and Vanrolleghem, P.A. (2006). Dynamic scheduling of computationally intensive applications on unreliable infrastructures. In: *Proceedings of the 2006 European Modelling and Simulation Symposium*, Barcelona, Spain, 4-6 October 2006.
- Ciacci, G. (2004). Evaluating costs and benefits of advanced control for wastewater treatment plants: the MAgIC methodology. MSc. thesis, BIOMATH, Ghent University, Belgium.
- Claeys, F., Chtepen, M., Benedetti, L., Dhoedt, B. and Vanrolleghem, P.A. (2006a). Distributed virtual experiments in water quality management. *Water Science and Technology* 53(1), 297-305.

## References

---

- Claeys, F., De Pauw, D.J.W., Benedetti, L. and Vanrolleghem, P.A. (2006b). Tornado: A versatile and efficient modeling & virtual experimentation kernel for water quality systems, In: Proceedings of iEMSs 2006, Burlington, VT, USA, 10-13 July 2006.
- Claeys, F., Chtepen, M., Benedetti, L., De Keyser, W., Fritzson, P. and Vanrolleghem, P.A. (2006c). Towards transparent distributed execution in the Tornado framework, In: Proceedings of Environmental Applications and Distributed Computing 2006, Bratislava, Slovakia, 16-18 October 2006.
- Claeys, P., Claeys, F., De Baets, B. and Vanrolleghem P.A. (2006d). Intelligent configuration of numerical solvers of environmental ODE/DAE models using machine learning techniques, In: Proceedings of iEMSs 2006, VT, USA, 10-13 July 2006, Burlington.
- Clifforde, I. T., Tomicic, B. and Mark, O. (1999). Integrated wastewater management - A European vision for the future. In: Proceedings of 8th International Conference on Urban Storm Drainage., Sydney, Australia, 30 August - 3 September 1999.
- Copp, J., Spanjers, H. and Vanrolleghem, P.A. (eds) (2002). *Respirometry in Control of the Activated Sludge Process: Benchmarking Control Strategies*, IWA Publishing, London, UK.
- Copp, J., Jeppsson, U. and Rosen, C. (2003). Towards an ASM1eADM1 state variable interface for plant-wide wastewater treatment modelling. In: Proceedings of the 76<sup>th</sup> Annual WEF Conference and Exposition, 11-15 October 2003, Los Angeles, USA.
- Daigger, G.T. and Roper, R.E. (1985). The relationship between SVI and activated sludge settling characteristics. *Journal WPCF* 57(8), 859-866.
- Danius, L. and Burström, F. (2001). Regional material flow analysis and data uncertainties: can the results be trusted?, In: Proceedings of 15th International Symposium on Informatics for Environmental Protection, Zurich (Switzerland), 10-12 October 2001.
- Deksissa T., J. Meirlaen, P.J. Ashton and Vanrolleghem, P.A. (2001). Simplifying dynamic river water quality modelling: a case study of inorganic nitrogen dynamics in the Crocodile River (South Africa). In: Proceedings of IWA conference on water and wastewater management for developing countries, Malaysia, 29-31 October 2001.
- De Pauw, N. and G. Vanhooren. (1983). Method for biological quality assessment of water courses in Belgium. *Hydrobiologia* 100, 153-168.
- De Toffol S., Achleitner S., Engelhard C. and Rauch W. (2005). Challenges in the implementation of the Water Framework Directive: The case study of the alpine river Drau in Austria. *Water Science and Technology* 52 (9), 243-250.
- Devisscher, M., Ciacci, G., Fé, L., Benedetti, L., Bixio, D., Thoeye, C., De Gueldre, G., Marsili-Libelli, S. and Vanrolleghem, P.A. (2006). Estimating costs and benefits of advanced control for wastewater treatment plants - the MAgIC methodology. *Water Science and Technology* 53(4-5), 215-223.
- Dominguez, D. and Gujer, W. (2006). Evolution of a wastewater treatment plant challenges traditional design concepts. *Water Research* 40, 1389-1396.
- EEA (1999). *Environment in the European Union at the turn of the century*. European Environmental Agency.
- Finnveden, G. and Moberg, Å. (2005). Environmental systems analysis tools – an overview. *Journal of Cleaner Production* 13(12), 1165-1173.

- Focht, D.D. and Verstraete, W. (1977). *Advances in microbial ecology*. Alexander, M. (ed), pp. 135-214, Plenum Press, New York, USA.
- Fronteau, C., Bauwens, W. and Vanrolleghem, P. A. (1997). Integrated modelling comparison of state variables, processes and parameters in sewer and wastewater treatment models. *Water Science and Technology* 36 (5), 373-380.
- Fujimoto, R. (2000). *Parallel and Distributed Simulation Systems*, Wiley Interscience, Hoboken, NJ, USA.
- Gernaey, K. and Jørgensen, S.B. (2004a). Benchmarking combined biological phosphorous and nitrogen removal wastewater treatment processes. *Control Engineering Practice* 12, 357-373.
- Gernaey, K., van Loosdrecht, M.C.M., Henze, M., Lind, M. and Jørgensen, B. (2004b). Activated sludge wastewater treatment plant modelling and simulation: state of the art. *Environmental Modelling & Software* 19, 763-783.
- Gernaey, K., Rosen, C., Benedetti, L. and Jeppsson, U. (2005a). Phenomenological modelling of wastewater treatment plant influent disturbance scenarios, In: *Proceedings of 10th International Conference on Urban Drainage (ICUD)*, Copenhagen, Denmark, 21-26 August 2005.
- Gernaey, K., Rosen, C. and Jeppsson, U. (2005b). BSM2: A model for dynamic influent data generation. Technical report. Department of Industrial Electrical Engineering and Automation. Lund University, Lund, Sweden.
- Gillot, S., De Clercq, B., Defour, D., Simoens, F., Gernaey, K. and Vanrolleghem, P. A. (1999). Optimization of wastewater treatment plant design and operation using simulation and cost analysis. In: *Proceedings of 72<sup>nd</sup> Annual WEF Conference and Exposition*, New Orleans, USA, 9-13 October 1999.
- Gillot, S. and Vanrolleghem, P. A. (2003). Equilibrium temperature in aerated basins—comparison of two prediction models. *Water Research* 37(15), 3742-3748.
- Griffiths, M. (2002). The European Water Framework Directive: an approach to integrated river basin management. *European Water Management Online* (2002/5).
- Gujer, W. (2006). Activated sludge modelling: past, present and future. *Water Science and Technology* 53(3), 111-119.
- Günthert, F. W. and Reicherter, E. (2001). *Investitionskosten der Abwasserentsorgung*, Oldenbourg Verlag, Oldenbourg, Germany.
- Henze, M., Gujer, W., Mino, T. and van Loosdrecht, M. C. M. (2000). *Activated sludge models ASM1, ASM2, ASM2d and ASM3*. IWA, London, UK.
- Hellström, D., Jeppsson, U. and Kärrman, E. (2000). A framework for systems analysis of sustainable urban water management. *Environmental Impact Assessment Review* 20, 311-321.
- Huang, G.H. and Xia, J. (2001). Barriers to sustainable water quality management. *Journal of Environmental Management* 61, 1-23.
- Huisman, J.L., Krebs, P. and Gujer, W. (2003). Integral and unified model for the sewer and wastewater treatment plant focusing on transformations. *Water Science and Technology* 47(12), 65-71.
- Hukkinen, J. (2003). From groundless universalism to grounded generalism: improving ecological economic indicators of human-environmental interaction. *Ecological Economics* (44), 11-27.

## References

---

- Hulsbeek, J.J.W., Kruit, J., Roeleveld, P.J. and van Loosdrecht, M.C.M. (2002). A practical protocol for dynamic modelling of activated sludge systems. *Water Science and Technology* 45(6), 127-136.
- Ingildsen, P. (2002). Realising Full-Scale Control in Wastewater Treatment Systems Using In Situ Nutrient Sensors. Ph.D. thesis. Department of Industrial Electrical Engineering and Automation, Lund University, Sweden.
- Ingildsen, P., Jeppsson, U. and Olsson, G. (2002). Dissolved oxygen controller based on on-line measurements of ammonium combining feed-forward and feedback. *Water Science and Technology*, 45(4-5), 453-460.
- Jardin, N. (2003). Vereinheitlichung und Herleitung von Bemessungswerten für Abwasseranlagen (A 198), In: Proceedings of Regen- und Mischwasserbehandlung Seminar, Würzburg, Technische Akademie Hannover (Germany), 23-24 September 2003.
- Jeppsson, U. and Hellström, D. (2002). Systems analysis for environmental assessment of urban water and wastewater systems. *Water Science and Technology* 46(6-7), 121-129.
- Jeppsson, U., Rosen, C., Alex, J., Copp, J., Gernaey, K.V., Pons, M.-N. and Vanrolleghem, P.A. (2006). Towards a benchmark simulation model for plant-wide control strategy performance evaluation of WWTPs. *Water Science and Technology* 53(1), 287-295.
- Jesinghaus, J. (1999). A European system of environmental pressure indices - First volume of the environmental pressure indices handbook: The Indicators. European Commission, Joint Research Centre, Institute for Systems, Informatics and Safety (ISIS), Luxembourg.
- Jirka, G.H., Bleninger, T., Burrows, R. and Larsen, T. (2004). Environmental quality standards in the EC-Water Framework Directive: consequences for water pollution control for point sources. *European Water Management Online* (2004/01).
- Jobbágy, A., Tardy, G.M. and Literáthy, B. (2004). Enhanced nitrogen removal in the combined activated sludge-biofilter system of the Southpest wastewater treatment plant. *Water Science and Technology* 50(7), 1-8.
- Jones, R.M. and Takacs, I. (2004). Importance of anaerobic digestion modelling on predicting the overall performance of wastewater treatment plants. In: Proceedings of Anaerobic Digestion 2004, Tenth World Congress, Montreal, Canada, 29 August - 2 September 2004.
- Kallis, G. and Butler, D. (2001). The EU water framework directive: measures and implications. *Water Policy* 3, 125-142.
- Kayser, R. (1990). Process Control and Expert Systems for Advanced Wastewater Treatment Plants. In: Briggs, R. (ed.). *Instrumentation, Control & Automation of Water and Wastewater Treatment and Transport Systems*. Pergamon Press, London, UK.
- Krebs, P. (1996). Interdependencies and dynamics within the urban water management. *EAWAG news* 41, 14-16.
- Krebs, P. (2000). Immissionskonzept in der Siedlungsentwässerung vor dem Hintergrund der EU Wasserrahmenrichtlinie. In: Proceedings of "14. Flockungstage 2000", Institut für Siedlungswasserwirtschaft (ISWW), Karlsruhe, Germany, 28-29 November 2000.
- Kroiss, H., Klager, F., Winkler, S., Wandl, G. and Svardal, K. (2004). Nutrient removal process development and full scale implementation at the 4 mio. P.E. main treatment plant of Vienna, Austria. *Water Science and Technology* 50(7), 19-26.



- Lampert, C. and Brunner, P.H. (1999). Materials accounting as a policy tool for nutrient management in the Danube basin. *Water Science and Technology* 40(10), 43-49.
- Langergraber, G., Rieger, L., Winkler, S., Alex, J., Wiese, J., Owerdieck, C., Ahnert, M., Simon, J. and Maurer, M. (2004). A guideline for simulation studies of wastewater treatment plants. *Water Science and Technology* 50(7), 131-138.
- Larsen, T.A. (1999). Nutrient cycles in urban water management. *EAWAG news* (46), 21-23.
- Larsen, T.A. and Gujer, W. (1997). Sustainable urban water management - Technological implications. *EAWAG news* (43), 12-14.
- Lessard, P. and Beck, B. (1991). Dynamic modeling of primary sedimentation. *Journal of Environmental Engineering* 114, 753-769.
- Lindberg, C. and Carlsson, B. (1996). Adaptive Control of External Carbon Flow Rate in an Activated Sludge Process. *Water Science and Technology* 34(3-4), 173-180.
- Lindqvist-Östblom, A., Sörme, L. and Södeberg, H. (2001). Substance flow analysis as a tool to support environmental management of heavy metals in wastewater treatment companies, In: *Proceedings of Workshop on Economic Growth, Material Flows and Environmental Pressure*, Stockholm (Sweden), 26-27 April 2001.
- Lindtner, S., Kroiss, H. and Nowak, O. (2004). Benchmarking of municipal wastewater treatment plants (an Austrian project). *Water Science and Technology* 50(7), 265-271.
- Longdon, J. (1992). Strategies for optimised nitrate reduction with primary denitrification. *Water Science and Technology* 26(5-6), 1087-1096.
- Maryns, F. and Bauwens, W. (1997). The application of the Activated Sludge Model No.1 to a river environment. *Water Science and Technology* 36(5), 201-208.
- Matos, R., Cardoso, A., Ashley, R.M., Duarte, P., Molinari, A. and Schulz, A. (2003). *Performance Indicators for Wastewater Services*. IWA Publishing, London, UK.
- McKay, M. D. (1988). Sensitivity and uncertainty analysis using a statistical sample of input values. In: *Uncertainty Analysis*. Y. Ronen (ed.), CRC Press, Inc., Boca Raton, FL, USA, pp. 145-186.
- Meirlaen, J., Huyghebaert, B., Sforzi, F., Benedetti, L. and Vanrolleghem, P.A. (2001). Fast, simultaneous simulation of the integrated urban wastewater system using mechanistic surrogate models. *Water Science and Technology* 43(7), 301-309.
- Melcer, H., Dold, P.L., Jones, R.M., Bye, C.M., Takacs, I., Stensel, H.D., Wilson, A.W., Sun, P. and Bury, S. (2003). *Methods for wastewater characterisation in activated sludge modelling*. Water Environment Research Foundation, Alexandria, VA, USA - IWA Publishing, London, UK.
- Mourato, S., Matos, J., Almeida, M. and Hvitved-Jacobsen, T. (2003). Modelling in-sewer pollutant degradation processes in the Costa do Estoril sewer system. *Water Science and Technology* 47(4), 93-100.
- MURL (1999). *Energie in Kläranlagen Handbuch*, Ministerium für Umwelt, Raumordnung und Landwirtschaft des Landes NRW.
- Neumann, M.B., Ort, C., Daebel, H., Gujer, W. (2005). Legal criteria, variability and uncertainty in the design of CSO retention. In: *Proceedings of the NOVATECH 2004*, Lyon, France, 6-10 June 2004.

## References

---

- Olsson, G. and Newell, B. (1999). *Wastewater Treatment Systems. Modelling, Diagnosis and Control*. IWA Publishing, London, UK.
- Otterpohl R. and Freund M. (1992). Dynamic Models for Clarifiers of Activated Sludge Plants with dry and wet weather flows, *Water Science and Technology* 26 (5-6), 1391-1400.
- Peng, Y., Ma, Y., Wang, S. and Wang, X. (2005). Fuzzy control of nitrogen removal in predenitrification process using ORP. *Water Science and Technology* 52(12), 161-169.
- Pleau, M., Pelletier, G., Colas, H., Lavallee, P. and Bonin, R. (2001). Global predictive realtime control of Quebec Urban community's westerly sewer network. *Water Science and Technology* 43 (7), 123-130.
- Prati, L., Pavanello, R. and Pesarin, F. (1971). Assessment of surface water quality by a single index of pollution. *Water Research* 5, 741-751.
- Rauch, W., Aalderink, H., Krebs, P., Schilling, W. and Vanrolleghem, P.A. (1998). Requirements for integrated wastewater models - driven by receiving water objectives. *Water Science and Technology* 38(11), 97-104.
- Rauch, W., Bertrand-Krajewski, J.-L., Krebs, P., Mark, O., Schilling, W., Schütze, M. and Vanrolleghem, P.A. (2002a). Deterministic modelling of integrated urban drainage systems. *Water Science and Technology* 45(3), 81-94.
- Rauch, W., Krejci, V. and Gujer, W. (2002b). REBEKA - a software tool for planning urban drainage on the basis of predicted impacts on receiving waters. *Urban Water* 4(4), 355-361.
- Reichert, P., Borchardt, D., Henze, M., Rauch, W., Shanahan, P., Somlyódy, L. and Vanrolleghem, P. A. (2001). *River water quality model No. 1 (RWQM1)*, IWA Publishing, London, UK.
- Reichert, P. and Vanrolleghem, P.A. (2001). Identifiability and uncertainty analysis of the River Water Quality Model No. 1 (RWQM1) *Water Science and Technology* 43(7), 329-338.
- Roda, I.R., Poch, M. and Banares-Alcantara, R. (2000). Application of a support system to the design of wastewater treatment plants. *Artificial Intelligence in Engineering* 14(1), 45-61.
- Rosen, C., Jeppsson, U. and Vanrolleghem P.A. (2004). Towards a common benchmark for long-term process control and monitoring performance evaluation. *Water Science and Technology* (50)11, 41-49.
- Rousseau, D., Verdonck, F., Moerman, O., Carrette, R., Thoeye, C., Meirlaen, J. and Vanrolleghem, P.A. (2001). Development of a risk assessment based technique for design/retrofitting of WWTPs. *Water Science and Technology* 43(7), 287-294.
- Saltelli, A., Ratto, M., Tarantola, S. and Campolongo, F. (2005). Sensitivity analysis for chemical models. *Chemical Reviews* 105(7), 2811-2827.
- Samuelsson, P. (2005). *Control of Nitrogen Removal in Activated Sludge Processes*. PhD thesis, Faculty of Science and Technology, Uppsala University, Sweden.
- Schertenleib, R. and Gujer, W. (2000). On the path to new strategies in urban water management. *EAWAG news* (48), 3-5.
- Schlütter, F. and Mark, O. (2003). Dynamic modelling of pollutants from CSOs. *Water Science and Technology* 47 (4), 149-156.
- Schütze, M., Butler, D. and Beck, B. (1999). Optimisation of control strategies for the urban wastewater system - an integrated approach. *Water Science and Technology* 39 (9), 209-216.

- Schütze, M., Butler, D. and Beck, B. (2002). Modelling, simulation and control of urban wastewater systems, Springer Verlag, London, UK.
- Shanahan, P., Henze, M., Koncsos, L., Rauch, W., Reichert, P., Somlyódy, L. and Vanrolleghem, P. A. (1998). River water quality modeling: II. Problems of the art. *Water Science and Technology* 38(11), 245-252.
- Sin, G., Van Hulle, S.W.H., De Pauw, D.J.W., van Griensven, A. and Vanrolleghem, P.A. (2005). A critical comparison of systematic calibration protocols for activated sludge models: A SWOT analysis. *Water Research* 39, 2459-2474.
- Solvi, A.-M., Benedetti, L., Gillé, S., Schlosseler, P., Weidenhaupt, A. and Vanrolleghem, P.A. (2005). Integrated urban catchment modelling for a sewer-treatment-river system in Luxembourg. In: *Proceedings of 10<sup>th</sup> ICUD, Copenhagen, Denmark, 21-26 August 2005*.
- Solvi, A.-M., Benedetti, L., Vandenberghe, V., Gillé, S., Schlosseler, P., Weidenhaupt, A. and Vanrolleghem, P.A. (2006). Implementation of an integrated model for optimised urban wastewater management in view of better river water quality: A case study. In: *Proceedings of IWA World Water Congress 2006, Beijing, China, 10-14 September 2006*.
- Sörme, L. and Langerkvist, R. (2002). Sources of heavy metals in urban wastewater in Stockholm. *The Science of the Total Environment* (298), 131-145.
- Spanjers, H., Vanrolleghem, P.A., Olsson, G and Dold, P.L. (1998). *Respirometry in Control of the Activated Sludge Process: Principles*. IAWQ Task Group on Respirometry, Scientific and Technical Report No.7, IAWQ, London, UK.
- Spérandio, M. and Queinnec, I. (2004). Online estimation of wastewater nitrifiable nitrogen, nitrification and denitrification rates, using ORP and DO dynamics. *Water Science and Technology* 49(1), 31-38.
- Starkl, M. and Brunner, N. (2004). Feasibility versus sustainability in urban water management. *Journal of Environmental Management* 71, 245-260.
- Starkl, M., Brunner, N., Grasser, U., Moog, U., Stagl, S., Kärrman, E. and Wimmer, J. (2005). Analysis and evaluation of methodologies to assess technical urban water systems. *Water Science and Technology* 52(9), 43-51.
- Stemplewski, J., Schulz, A. and Schön, J. (2001). Benchmarking - an approach to efficiency enhancement in planning, construction and operation of wastewater treatment plants. *Water Science and Technology* 44(2-3), 111-117.
- Suescun, J., Ostolaza, X., Garcia-Sanz, M. and Ayesa, E. (2001). Real-time control strategies for predenitrification-nitrification activated sludge plants biodegradation control. *Water Science and Technology* 43(1), 209-216.
- Takacs, I., Patry, G.G. and Nolasco, D. (1991). A dynamic model of the clarification - thickening process. *Water Research* 25(10), 1263-1275.
- Takacs, I. and Vanrolleghem, P.A. (2006). Elemental balances in activated sludge modelling. In: *Proceedings of IWA World Water Congress 2006, Beijing, China, 10-14 September 2006*.
- Talati, S.N. and Stenstrom, M. (1990). Aeration basin heat loss. *Journal of Environmental Engineering* (116), 70-86.
- Taylor, S., Williams, W., Murrel, K. and Berislav, T. (2000). Status and development plans for the integrated catchment simulator. In: *Proceedings of IMUG2000, Prague, 12-14 April 2000*.

## References

---

- Tchobanoglous, G., Burton, F. and Stensel, D.H. (2002). *Wastewater Engineering: Treatment and Reuse*. McGraw-Hill, New York, USA.
- USEPA (1986). *Quality Criteria for Water*. EPA-440/5-86-001. Office of Water.
- USEPA (1991). *Technical Support Document for Water Quality-Based Toxics Control*. EPA-505/2-90-001. Office of Water.
- USEPA (1994). *Water Quality Standards Handbook: Second Edition*. EPA 823-B-94-005a. Office of Water.
- USEPA (1996). *NPDES Permit Writers' Manual*. EPA 833-B-96-003. Office of Water.
- USEPA (2002). *National Recommended Water Quality Criteria: 2002*. EPA-822-R-02-047. Office of Water.
- Vandenbergh, V., Benedetti, L. and Vanrolleghem, P.A. (2004). Synergetic use of the degrees of freedom to improve the urban wastewater system, In: *Proceedings of IWA WWC 2004*, Marrakech, Morocco, 19-24 September 2004.
- Vanhooren, H., Meirlaen, J., Amerlink, Y., Claeys, F., Vangheluwe, H. and Vanrolleghem, P.A. (2003). WEST: Modelling biological wastewater treatment. *Journal of Hydroinformatics* 5(1), 27-50.
- Vanrolleghem, P. A., Jeppsson, U., Carstensen, J., Carlsson, B. and Olsson, G. (1996). Integration of wastewater treatment plant design and operation - a systematic approach using cost functions. *Water Science and Technology* 34 (3-4), 159-171.
- Vanrolleghem, P.A., Insel, G., Petersen, B., Sin, G., De Pauw, D.J.W., Nopens, I., Weijers, S. and Gernaey, K. (2003). A comprehensive model calibration procedure for activated sludge models, In: *Proceedings of WEFTEC 2003: 76th Annual Technical Exhibition & Conference*, Los Angeles, USA, 11-15 October 2003.
- Vanrolleghem, P.A., Benedetti, L. and Meirlaen, J. (2005a). Modelling and real-time control of the integrated urban wastewater system. *Environmental Modelling & Software* 20, 427-442.
- Vanrolleghem, P.A., Rosen, C., Zaher, U., Copp, J., Benedetti, L., Ayesa, E. and Jeppsson, U. (2005b). Continuity-based interfacing of models for wastewater systems described by Petersen matrices. *Water Science and Technology* 52(1-2), 493-500.
- Vesilind, P.A., (2003). *Wastewater Treatment Plant Design*, Water Environment Federation & IWA Publishing, London, UK.
- VMM (2001). *General Water Quality Plan 2 - 10.Nete*. Flemish Environment Agency (Belgium).
- Volcke, E.I.P, van Loosdrecht, M.C.M. and Vanrolleghem, P.A. (2006). Continuity-based model interfacing for plant-wide simulation: A general approach. *Water Research* 40(15), 2817-2828.
- Walley, P. (1991). *Statistical Reasoning with Imprecise Probabilities*, Chapman and Hall, Boca Raton, FL, USA.
- WEF (1998). *Design of Municipal Wastewater Treatment Plants*. Water Environment Federation. Alexandria, Virginia, USA.
- Yuan, Z., Bogaert, H., Vanrolleghem, P.A., Thoeye, C., Vansteenkiste, G. and Verstraete, W. (1997). Control of external carbon addition to predenitrifying systems. *Journal of Environmental Engineering* 123(11), 1080-1086.
- Yuan, Z., Bogaert, H., Vansteenkiste, G. and Verstraete, W. (1998). Sludge storage for countering

- 
- nitrogen shock loads and toxicity incidents. *Water Science and Technology* 37(12), 173-180.
- Yuan, Z., Bogaert, H., Leten, J. and Verstraete, W. (2000). Reducing the size of a nitrogen removal activated sludge plant by shortening the retention time of inert solids via sludge storage. *Water Science and Technology* 34(2), 539-549.
- Yuan, Z., Oehmen, A. and Ingildsen, P. (2002). Control of nitrate recirculation flow in predenitrification systems. *Water Science and Technology* 45(4-5), 29-36.
- Yuan, Z. and Keller, J. (2003). Integrated control of nitrate recirculation and external carbon addition in a predenitrification system. *Water Science and Technology* 48(11-12), 345-354.
- Zaher, U., Grau, P., Benedetti, L., Ayasa, E. and Vanrolleghem, P.A. (2007). Transformers for interfacing anaerobic digestion models to pre- and post-treatment processes in a plant-wide modelling context. *Environmental Modelling & Software* 22(1), 40-85.
- Zessner, M. and Lindtner, S. (2005). Estimations of municipal point sources pollution in the context of river basin management. *Water Science and Technology* 52(9), 175-182.



## SUMMARY

The introduction of the EU Water Framework Directive requires compliance with effluent quality standards and with receiving water quality standards. Therefore, the boundaries of the system to be managed expand from single structures (e.g. wastewater treatment plant) or sectors (e.g. agriculture) to all activities affecting the water environment in the river basin.

This increased complexity implies that the evaluation of the impact of measures on the water quality should be evaluated with instruments able to cope with such complexity, both from the methodological point of view – by developing and applying systems analysis investigations and modelling uncertainty assessment tools – and by making the developed methodology applicable in practice by means of adequate software tools.

Urban wastewater systems (UWWSs) – on which this dissertation focuses – are crucial components of river basins, since they usually contribute substantially to the pollution loads affecting the receiving water body. They also have more flexibility in their operation and management than other subsystems as agriculture.

One part of this dissertation tries to answer the question “where” to improve the UWWS by means of systems analysis. A case study is presented and tackled with the help of substance flow analysis (SFA) to identify the critical paths and of the evaluation of a suite of performance indicators. The case study was the Nete river basin in Belgium, being the basin with the largest data quantity available in Flanders. It consists of by 29 sewer catchments studied both separately and all together as a whole basin.

SFA allowed to identify the pressures on the receiving water through organic pollution and nutrients from households, treatment plants, industry and agriculture. Evidently, information gaps were detected especially regarding diffuse pollution and regarding the availability of reliable data on micropollutants like heavy metals. The indicators – evaluated only for wastewater collection and treatment systems – highlighted the critical structures in the basin. A considerable amount of infiltration water was estimated to enter the sewer system, causing problems of higher treatment costs and lower treatment efficiency.

The spatial scale of the study was found to be of paramount importance, since indicators evaluated for single catchments were in some cases showing extreme values, while the same indicators evaluated for the whole basin had values very well in reported ranges.

The other main part of this dissertations deals with the question “how” to improve the UWWS, by proposing a systematic methodology to design correction measures, illustrated by the example of

WWTP design and upgrade. The evaluation of the options is divided in emission-based (considering the quality of the plant effluent) and immission-based (judging on the basis of the receiving water quality).

The first step consists of a pre-selection of alternatives, in which the non-feasible options are discarded and the most promising ones are selected for further detailed analysis. The next step is the generation of influent time series to be fed to the WWTP models. This is done with a new phenomenological model of the draining catchment and sewer system. One year time series with data every 15 minutes are produced which realistically represent the influent dynamics with time scales varying from minutes (e.g. first flush effect) to months (e.g. seasonality in infiltration rate).

Ten different treatment process configurations were selected for the comparison. The modelling of the WWTPs is based on dimensioning using the ATV-131 guidelines and by using the ASM2d model to describe the dynamics of the activated sludge processes. Eleven options to upgrade a low loaded system were selected for evaluation, partly requiring real-time control (RTC) and partly the construction of additional treatment volume. All configurations were implemented in Tornado, the new back-end of the WEST software, which allows for high flexibility of use and short simulation time.

For the immission-based evaluation, the integration of the WWTP model with a river model – based on a real river modelled with a simplified version of RWQM1 – was made by means of the continuity-based interfacing method (CBIM) and the whole integrated model was implemented in Tornado.

It is deemed that modelling results should always be accompanied by information on the confidence of such predictions. Some probabilistic descriptors were developed and quantified for the options evaluation. The propagation of the uncertainty on model parameters was performed by means of Monte Carlo simulations making use of Typhoon, a software developed to distribute the large number of Monte Carlo simulations on a network of computers, which dramatically reduces the simulation time necessary to apply the proposed methodology.

The first example of emission-based evaluation shows the comparison of different activated sludge volumes for a low loaded system. The main result is that with a volume down to 60% of the one derived from the ATV-131 guideline, the plant is complying with emission limits on yearly average values. The comparison of the ten different process configurations allowed to conclude that given the assumed boundary conditions, alternating systems show the best treatment cost-efficiency. Concerning the upgrade options, RTC upgrades showed good potential for low-cost compliance with regulations, but with higher risk of limits exceedance than with the increase of treatment volumes, which allow for more stable process performance but at higher cost.

The immission-based evaluation of some plant upgrade options revealed that considering the system from a holistic point of view can lead to substantial savings. The option which consisted in just allowing more water to be treated in the plant – hence implying lower effluent quality but less untreated water to be directly discharged in the river – resulted in better environmental and economic performance than the one involving the extension of the treatment volume.

Finally, perspectives for future research are given, such as the extension of the design assessment methodology to include the whole wastewater system and other pollutants and the use of Bayesian networks to frame the performed uncertainty assessment in a wider context.



## SAMENVATTING

Met de invoering van de EU Kaderrichtlijn Water moet voldaan worden aan waterkwaliteitsnormen voor zowel effluenten als ontvangende waterlichamen. Hierdoor verbreden de grenzen van het te besturen systeem van een eenvoudige structuur (bv. de waterzuiveringsinstallatie) of sector (vb. landbouw) naar alle activiteiten die de kwaliteit van het water in het (deel)stroomgebied beïnvloeden.

Dit brengt met zich mee dat de impact van waterkwaliteitsmaatregelen geëvalueerd moet worden met instrumenten die met deze toegenomen complexiteit overweg kunnen, zowel vanuit methodologisch standpunt – door het ontwikkelen en toepassen van technieken voor systeem- en modelonzekerheidsanalyse – als door er voor te zorgen dat de ontwikkelde methodologie in de praktijk toepasbaar is door gebruik te maken van aangepaste softwarepakketten.

Dit doctoraat richt zich op stedelijke afvalwatersystemen (SAWS-en), wat cruciale onderdelen van (deel)stroomgebieden zijn vermits hun vuilvrachten in belangrijke mate impact hebben op de ontvangende waterlichamen. Ze hebben eveneens een meer flexibele werking en management dan andere systemen zoals bv. de landbouw.

Een deel van dit proefschrift probeert met systeemanalyse een antwoord te geven op de vraag “waar” SAWS verbeterd kunnen worden. Een gevallenstudie is voorgesteld en onderworpen aan een substantie-stroomdiagram-analyse (SSA) om de kritische stromen te identificeren en om een set van prestatie-indicatoren te evalueren. Als gevallenstudie diende het deelstroomgebied van de Nete, een gebied dat de meeste gegevens beschikbaar heeft van Vlaanderen. Het bestaat uit 29 rioolbekkens, die zowel afzonderlijk als gezamenlijk bestudeerd zijn.

SSA laat toe om de druk op de ontvangende waterlichamen te identificeren voor de organische polluenten en de nutriënten afkomstig van huishoudens, waterzuiveringsinstallaties, industrie en landbouw. Uiteraard werden er tekorten aan informatie gedetecteerd, vooral voor wat betreft de diffuse verontreiniging en de beschikbaarheid van betrouwbare gegevens omtrent micropolluenten zoals zware metalen. De indicatoren – enkel geëvalueerd voor de waterzuiveringscollectoren en de waterzuiveringsinstallaties – brachten de cruciale structuren van het bekken aan het licht. Een aanzienlijke hoeveelheid infiltratiewater naar het rioolsysteem werd ingeschat, wat problemen als hogere waterzuiveringskosten en een lagere zuiveringsefficiëntie veroorzaakt.

De ruimtelijke schaal van de studie bleek van cruciaal belang te zijn, vermits de indicatoren geëvalueerd werden voor enkelvoudige bekkens, waar in de meeste gevallen extreme waarden bekomen werden, terwijl voor dezelfde indicatoren over het hele bekken genomen, waarden bekomen werden die overeenkomen met gerapporteerde intervallen van waarden.

Het ander gedeelte van dit proefschrift behandelt de vraag “hoe” SAWS verbeterd kunnen worden met behulp van een systematische methodologie voor het ontwerp van

verbeteringsmaatregelen, wat geïllustreerd werd met het voorbeeld van ontwerp en opwaardering van een RWZI.

De evaluatie van de opties is onderverdeeld in emissie-gebaseerde (beoordeling volgens de kwaliteit van de effluënten van de zuiveringsinstallatie) en immissie-gebaseerde (beoordeling volgens de kwaliteit van de ontvangende waterloop) maatregelen.

De eerste stap bestaat uit een preselectie van alternatieven, waarin de niet-haalbare opties werden weggelaten en de meest beloftevolle werden geselecteerd voor verdere diepgaande analyse. De volgende stap is het aanmaken van tijdreeksen van inkomende vuilvrachten die als input dienen voor de RWZI modellen. Dit werd gedaan door middel van een nieuw fenomenologisch model van het bekken en het rioleringsysteem. Tijdreeksen van 1 jaar met data voor elke 15 minuten zijn zo aangemaakt dat deze op een realistische manier de influent dynamiek weerspiegelen met tijdsschalen die variëren van minuten (bijv. 'first flush' effecten) tot maanden (bijv. seizoenaliteit in infiltratiesnelheid).

Tien verschillende procesconfiguraties werden uitgekozen voor de vergelijking. Het modelleren van de RWZI's is gebaseerd op de dimensionering die beschreven is in de ATV-131 richtlijnen en het ASM2d model werd gebruikt om de dynamiek van het actief slib proces te beschrijven. Elf opties voor de opwaardering van een laag belast systeem werden geselecteerd voor evaluatie, waarbij voor een deel procesregeling en voor het andere deel de bouw van een extra behandelingseenheid benut werd. Alle configuraties werden geïmplementeerd in Tornado, de nieuwe uitbreiding van de WEST software, waarmee een hoge flexibiliteit bekomen wordt in gebruik en tegelijk een korte simulatie tijd gehaald wordt.

Voor de immissie-gebaseerde evaluatie werd een geïntegreerd model gemaakt van door combinatie van het RWZI model met een rivier model – gebaseerd op een reële rivier gemodelleerd met een vereenvoudigde versie van het RWQM1 model – met de continuïteitsgebaseerde interface methode en het geheel werd geïmplementeerd in Tornado.

Er wordt gesteld dat modelresultaten altijd moeten vergezeld worden van betrouwbaarheidsinformatie over zulke voorspellingen. Enkele probabilistische voorstellingswijzen werden ontwikkeld voor de evaluatie van de opties. De propagatie van de onzekerheid op de model parameters werd uitgevoerd door middel van Monte Carlo simulaties gebruik makende van Typhoon, een software ontwikkeld om een groot aantal Monte Carlo simulaties te verdelen over een netwerk van computers, zodat de simulatie tijd nodig om de voorgestelde methodes toe te passen drastisch kleiner wordt.

Het eerste voorbeeld van emissie-gebaseerde evaluatie toont de vergelijking van verschillende actief slib systemen voor een laag belast systeem. Het belangrijkste resultaat van deze gevallenstudie is dat men met een volume 60 % kleiner dan dat voorgesteld door de ATV-131 richtlijn, een installatie bekomt die voldoet aan de emissienormen op jaarlijks gemiddelde basis. De vergelijking van de tien verschillende configuraties laat toe te besluiten dat onder de gegeven condities, alternerende systemen de beste behandelingskost-efficiëntie geven. Met betrekking tot de opwaarderingsopties, toont opwaardering met procesregeling een goed potentieel om te voldoen aan de wetgeving met lage kosten maar met een hoger risico op limietoverschrijding dan opties met uitbreiding van behandelingseenheden, die een meer stabiel proces mogelijk maken maar met hogere kosten. De immissie-gebaseerde evaluatie van sommige installatie opwaarderingsopties maakte duidelijk dat men veel kan besparen wanneer men het systeem op een holistische manier beschouwd. De optie die enkel bestond uit het meer water toelaten om behandeld te worden in de zuiveringsinstallatie – wat dus een lagere effluentkwaliteit geeft, maar minder water onbehandeld in de rivier loost – resulteerde in betere milieu en economische prestaties dan de extensie van

behandelingsvolumes.

Tot slot werden perspectieven voor toekomstig onderzoek gegeven, zoals de uitbreiding van de ontwerpfase methodologie om het volledige afvalwatersysteem en andere polluenten erbij te beschouwen en het gebruik van bayesiaanse netwerken om de gebruikte onzekerheidsanalyse te kaderen in een bredere context.



# **APPENDIX A**

## **WWTP DESIGN CONFIGURATIONS**



## A2O ANAEROBIC-ANOXIC-OXIC

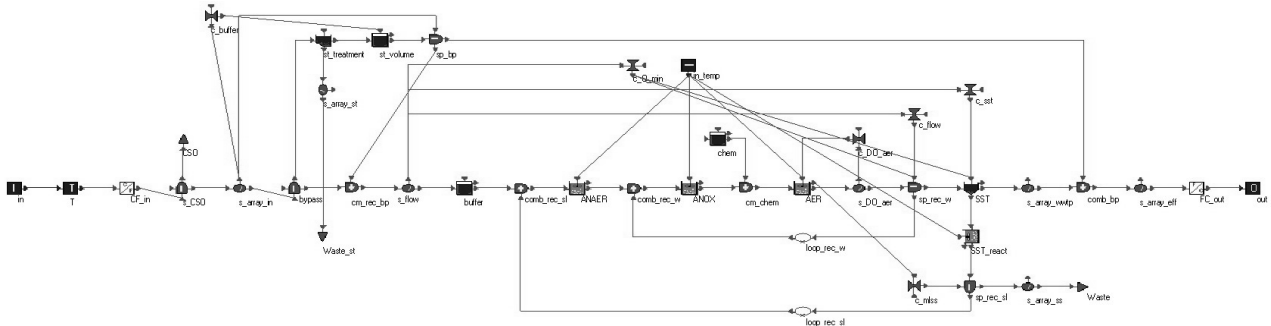

One limitation of this process is that nitrate returns to the anaerobic zone with the return sludge from the clarifier can reduce the effectiveness of the phosphorus removal. The magnitude of this effect is directly related to the levels of nitrate in the return sludge stream.

The efficiency of the biological P removal depends very much on the wastewater characterisation. To achieve low effluent concentration of both nitrogen and phosphorus a conflict can exist between the amount of substrate available and required. This is often the case with municipal wastewater. The appropriate utilisation of available substrate for the various biological processes is a critical success factor for the nutrient removal. For low effluent concentration of both nutrients, the focus is usually to first achieve the nitrogen removal requirements.

The flexibility of this configuration can be increased by dividing the anaerobic tank into zones which can be used for the denitrification during winter. In this case the required P removal can be ensured by adding precipitants.

## AO ANAEROBIC-OXIC

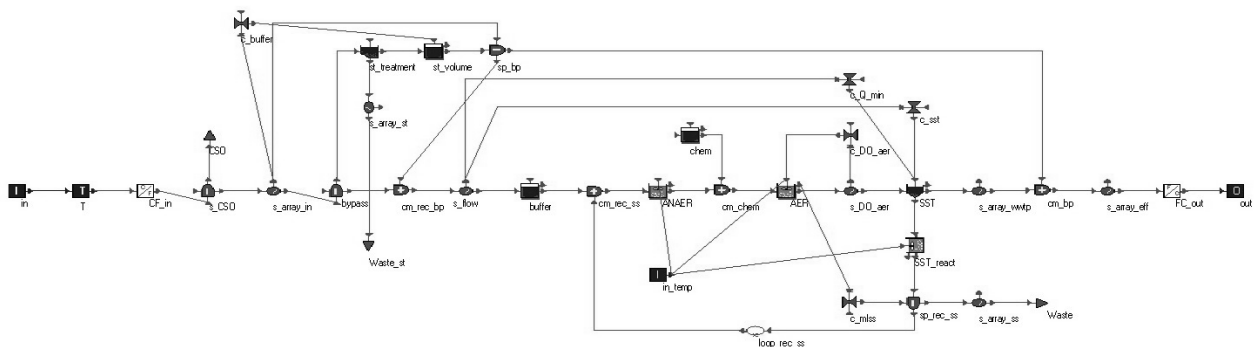

This process can only be used for the enhanced biological phosphorus removal. The anaerobic tank is followed by an aerobic tank. Due to the missing anoxic tank, nitrification processes should not occur in the aerobic tank. Otherwise nitrate would pass by the return sludge circle into the anaerobic tank and the biological P removal would be inhibited.

The efficiency of the biological P removal depends very much on the wastewater

characterisation.

This process is common for high loaded activated sludge plants.

## BDNP BIODENIPHO

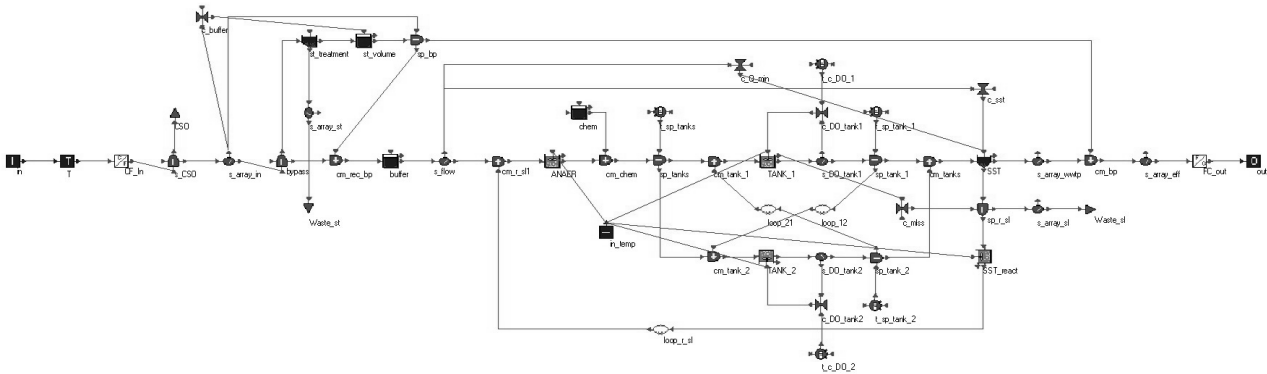

This process gives increased flexibility over continuous processes, in that e.g. the HRT can be adjusted by variation of the various phase lengths. The operation of this process can be customized to the daily, weekly, monthly, or seasonal variations. During low summer flow periods, for example, the anoxic phases may be extended to maximize denitrification, thus minimizing the aeration requirements as well as the associated energy costs. Conversely, during winter months, the oxic phases can be extended to ensure a sufficient aerated sludge age in order to maintain complete nitrification. Nitrate recycling from the aerobic to the anoxic tank is not required due to alternating processes, leading to some energy savings.

Since the return sludge is passed directly into the anaerobic tank it is very important to ensure a sufficient denitrification process to have low or zero nitrate concentration in the return sludge not to inhibit biological P removal.

The efficiency of the biological P removal depends very much on the wastewater characterisation. To achieve low effluent concentration of both nitrogen and phosphorous a conflict can exist between the amount of substrate available and required. This is often the case with municipal wastewater. The appropriate utilisation of available substrate for the various biological processes is a critical success factor for the nutrient removal. For low effluent concentration of both nutrients, the focus is usually to first achieve the nitrogen removal requirements.

Disadvantages are the wide area needed and that the tanks must be equipped identically with mixers and aerators (increase of investment costs).

A large number of online sensors are usually installed in these processes and skilled personnel are required to control the process.



## BDN BIODENITRO

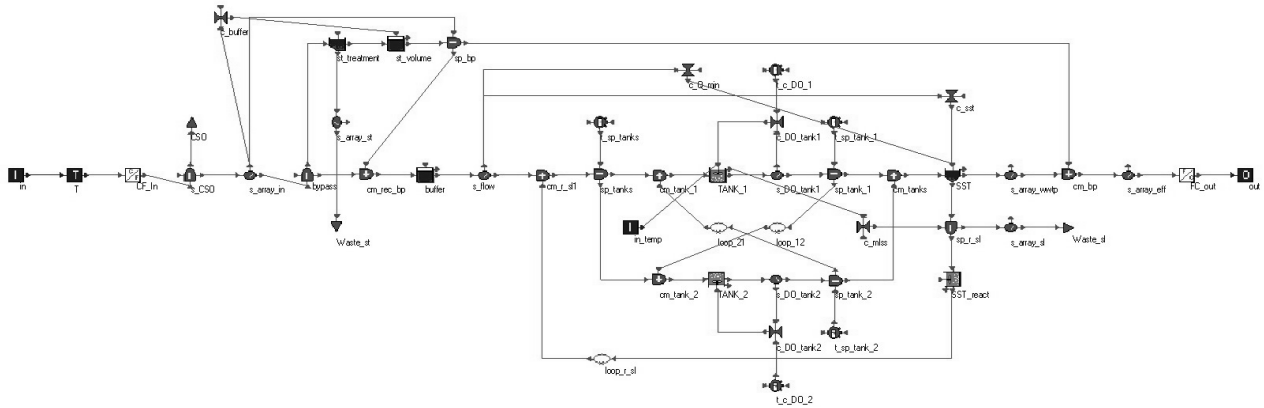

This alternating process can suit various design cases that can arise depending on the wastewater characteristics and effluent nitrogen requirements. It is flexible because of various combinations in the duration of the different phases. The operation of the Biodenitro process can be customized to the daily, weekly, monthly, or seasonal variations. During low summer flow periods, for example, the anoxic phases may be extended to maximize the denitrification, thus minimizing the aeration requirements as well as the associated energy costs. Conversely, during winter months, the oxic phases can be extended to ensure a sufficient supply of oxic sludge age in order to maintain complete nitrification.

The plant capacity can be increased by settling in the aeration tanks in situations with high hydraulic load. A large number of online sensors are usually installed in these processes and skilled personnel are required to control the process.

Nitrate recycling is not required due to alternating processes, leading to some energy savings.

Disadvantages are the wide area needed and that the tanks must be equipped identically with mixers and aerators (increase of investment costs).

## HLAS HIGH LOADED ACTIVATED SLUDGE

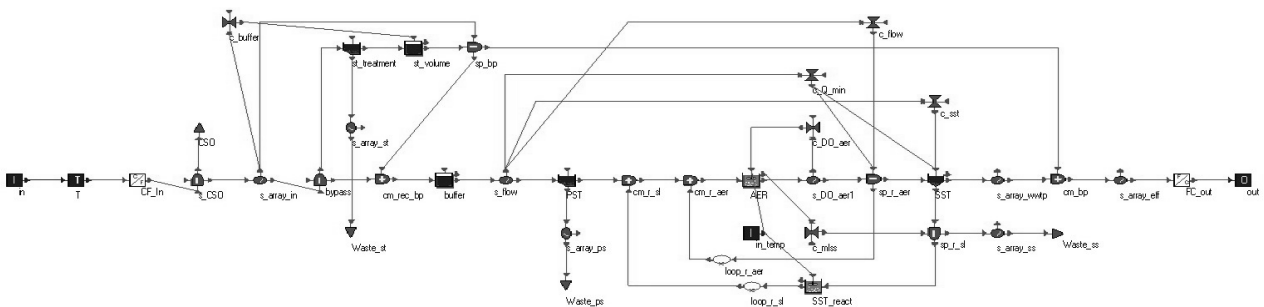

Primary settling in the presence of anaerobic digestion minimises the energy requirements and operating costs. The bio-gas produced by the anaerobic stabilised primary sludge can be used for

energy recovery. Costs are reduced by smaller excess sludge production. The energy consumption for aeration is reduced due to fewer solids in the influent of the biological reactor.

Digestion is a very effective and energy saving way of stabilising the raw sludge coming from the primary settling tank. However, digesters are uneconomical for small WWTP and aerobic sludge stabilisation using extended aeration is more suitable.

## LLAS LOW LOADED ACTIVATED SLUDGE

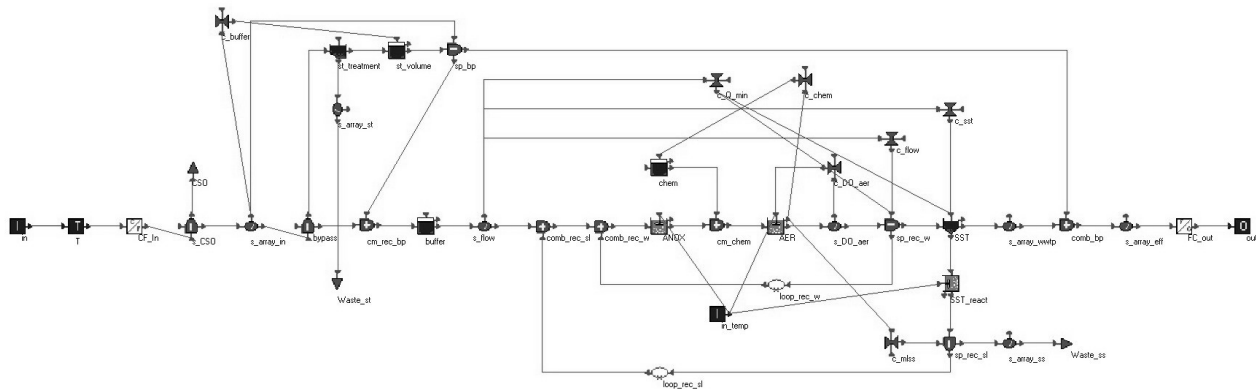

The biological nitrogen removal is sensitive to many parameters. Denitrification requires anoxic conditions as well as an organic carbon source. A high concentration of dissolved oxygen in the denitrification tank inhibits the denitrification process. Therefore an oxygen control in the nitrification tank is crucial for an efficient denitrification since less free oxygen is introduced into the denitrification tank by the internal recirculation.

Dividing the tanks into different zones increases the flexibility. In winter, the needed nitrification volume can be exceeded by aerating denitrification zones. In this case, the denitrification volume decreases and the nitrate concentration in the effluent rise. An adjusted internal recirculation flow depending on the denitrification capacity is important for an optimised denitrification and ensures a flexible operation. Compared to an oxidation ditch, additional costs for internal recycling equipment are higher.

This process needs a relatively low degree of automation. For an efficient operation an aeration control in the nitrification tank and a nitrate measurement in the effluent of the denitrification tank to adjust the internal cycle flow are necessary.

For a flexible operation special zones in the denitrification tank are equipped with stirrers and aeration elements which can be used either for denitrification or nitrification. These zones are characterised by a high equipment level.

Phosphorus is removed by simultaneous chemical precipitation. Due to the recirculation of the metal salts with the return sludge, the precipitant is fully exploited. The precipitant improves the settling characters of the activated sludge. The surplus sludge quantity increases due to the added salts. The chemical P precipitation is usually considered to be more reliable than biological P removal.

The sludge of activated sludge plants without primary settling tanks being wasted for disposal is often stabilised by extended aeration, typically for small WWTPs (<10.000PE). This type of plant is

characterised by a low maintenance effort, simple control requirements and high buffering capacity. The oxygen demand can be up to 50% higher, compared to plants with the same size with primary settler and a SRT <13d, while this process minimises the sludge handling.

The aerated tank is modelled with 1 tank for 3,000PE, 2 tanks in series for 30,000PE and 6 tanks in series for 300,000PE.

## LLAS\_PS LOW LOADED ACTIVATED SLUDGE WITH PRIMARY SETTLER

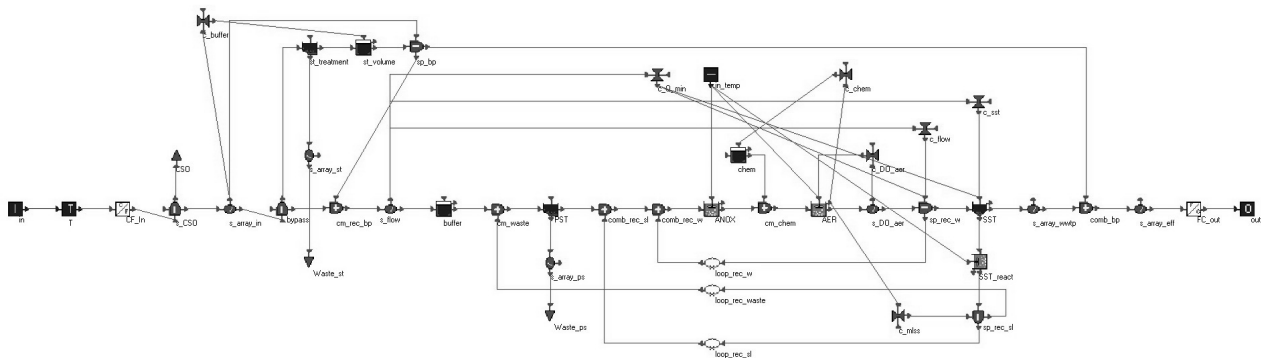

Primary settling in the presence of anaerobic digestion minimises the energy requirements and operating costs. The bio-gas produced by the anaerobic stabilised primary sludge can be used for energy recovery. Costs are reduced by smaller excess sludge production. The energy consumption for aeration is reduced due to fewer solids in the influent of the biological reactor.

The biological nitrogen removal is sensitive to many parameters. Denitrification requires anoxic conditions as well as an organic carbon source. A high concentration of dissolved oxygen in the denitrification tank inhibits the denitrification process. Therefore an oxygen control in the nitrification tank is crucial for an efficient denitrification since less free oxygen is introduced into the denitrification tank by the internal recirculation.

Dividing the tanks into different zones increases the flexibility. In winter, the needed nitrification volume can be exceeded by aerating denitrification zones. In this case, the denitrification volume decreases and the nitrate concentration in the effluent rise. An adjusted internal recirculation flow depending on the denitrification capacity is important for an optimised denitrification and ensures a flexible operation. Compared to an oxidation ditch, additional costs for internal recycling equipment are higher.

This process needs a relatively low degree of automation. For an efficient operation an aeration control in the nitrification tank and a nitrate measurement in the effluent of the denitrification tank to adjust the internal cycle flow are necessary.

For a flexible operation special zones in the denitrification tank are equipped with stirrers and aeration elements which can be used either for denitrification or nitrification. These zones are characterised by a high equipment level.

A primary settling bypass can be used in cases of insufficient substrate in the effluent of the primary settling tank to feed the denitrification tank with the required easily biodegradable COD fractions.

Digestion is a very effective and energy saving way of stabilising the raw sludge coming from

the primary settling tank. However, digesters are uneconomical for small WWTP and aerobic sludge stabilisation using extended aeration is more suitable.

The aerated tank is modelled with 1 tank for 3,000PE, 2 tanks in series for 30,000PE and 6 tanks in series for 300,000PE.

## OD\_BIOP OXIDATION DITCH WITH BIOLOGICAL P REMOVAL

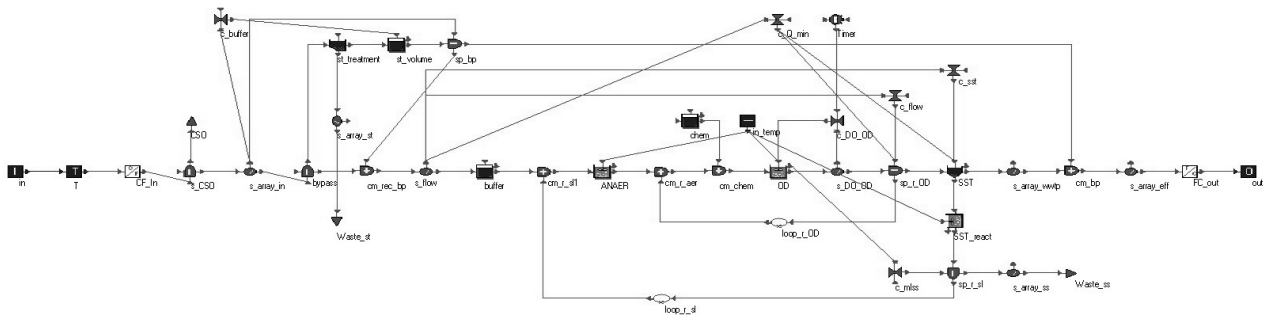

Oxidation ditches are single-sludge wastewater systems which are capable of achieving carbon oxidation, nitrification and denitrification. Due to the high internal recirculation rate, oxidation ditches have good buffering against shock loads. The total N removal efficiencies are similar to a pre-denitrification process, without the need for an anoxic basin and with decrease of operating costs. Compared to a pre-denitrification process no additional costs for internal recycling pumps and pipes are required. The flexibility can be increased by intermittent aeration. The degree of automation is very low.

The surplus sludge production resulting from the biological P removal is lower than from the chemical P removal. The biological P removal is inhibited by too much parasite water, low concentration of volatile fatty acids (VFA), low concentration of easily biodegradable fractions of COD, too much nitrate in the influent and/or return sludge and a high concentration of dissolved oxygen.

The efficiency of the bio-P depends very much on the wastewater characterisation. To achieve low effluent concentration of both nitrogen and phosphorous a conflict can exist between the amount of substrate available and required. This is often the case with municipal wastewater. The appropriate utilisation of available substrate for the various biological processes is a critical success factor for the nutrient removal. For low effluent concentration of both nutrients, the focus is usually to first achieve the nitrogen removal requirements.

The sludge of activated sludge plants without primary settling tanks being wasted for disposal is often stabilised by extended aeration, typically for small WWTPs (<10.000PE). This type of plant is characterised by a low maintenance effort, simple control requirements and high buffering capacity. The oxygen demand can be up to 50% higher, compared to plants with the same size with primary settler and a SRT <13d, while this process minimises the sludge handling.

## OD\_SIMP OXIDATION DITCH WITH SIMULTANEOUS P PRECIPITATION

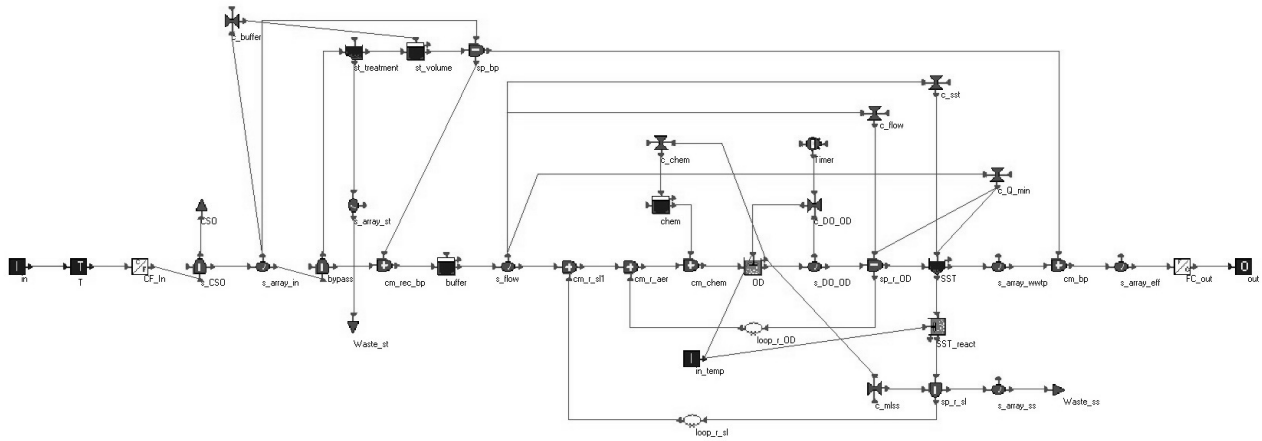

Oxidation ditches are single-sludge wastewater systems which are capable of achieving carbon oxidation, nitrification and denitrification. Due to the high internal recirculation rate, oxidation ditches have good buffering against shock loads. The total N removal efficiencies are similar to a pre-denitrification process, without the need for an anoxic basin and with decrease of operating costs. Compared to a pre-denitrification process no additional costs for internal recycling pumps and pipes are required. The flexibility can be increased by intermittent aeration. The degree of automation is very low.

P-precipitation is a reliable method to remove phosphorous from wastewater. The investment costs are lower than the investment costs for biological P removal, but the operating costs increase due to chemical consumption and due to an increased amount of sludge to be disposed of. The chemical precipitant causes environmental impacts like enrichment of heavy metals in the sludge of the WWTP, influence of the nitrification process and increase of salts in the receiving water.

The sludge of activated sludge plants without primary settling tanks being wasted for disposal is often stabilised by extended aeration, typically for small WWTPs (<10.000PE). This type of plant is characterised by a low maintenance effort, simple control requirements and high buffering capacity. The oxygen demand can be up to 50% higher, compared to plants with the same size with primary settler and a SRT <13d, while this process minimises the sludge handling.

# UCT UNIVERSITY OF CAPE TOWN

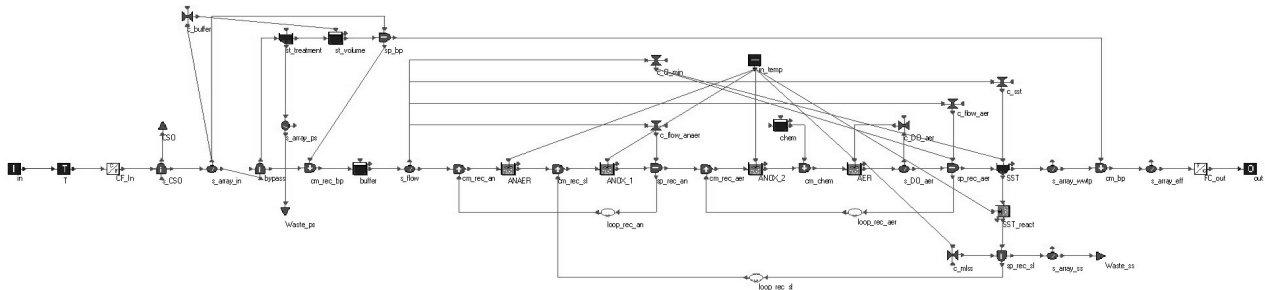

The UCT configuration recycles the return sludge directly into the anoxic zone to protect the anaerobic zone from nitrate. The denitrified sludge of the anoxic zone is returned to the anaerobic zone and should be controlled to have low or zero nitrates. The surplus sludge production resulting from the biological phosphorus removal is lower than the sludge from the chemical P removal and thus the waste disposal costs are reduced.

The biological P removal is inhibited by too much parasite water, low concentration of volatile fatty acids (VFA), low concentration of easily biodegradable fractions of COD, too much nitrate in the influent and/or return sludge and a high concentration of dissolved oxygen.

The efficiency of the bio-P depends very much on the wastewater characterisation. To achieve low effluent concentration of both nitrogen and phosphorous a conflict can exist between the amount of substrate available and required. This is often the case with municipal wastewater. The appropriate utilisation of available substrate for the various biological processes is a critical success factor for the nutrient removal. For low effluent concentration of both nutrients, the focus is usually to first achieve the nitrogen removal requirements.

One disadvantage for this configuration is the need for several recycle pumps and pipes. Compared to plants with nitrogen removal and chemical P precipitation an additional anaerobic tank with mixers is required (higher investment costs).

This configuration needs a higher degree of automation to ensure a stable effluent quality. The UCT process provides in principle the most reliable enhanced biological phosphorous removal, because of the protection of the anaerobic zone from nitrate.

## **APPENDIX B**

### **INFLUENT TRANSFORMER**





The transformer that translates the state variables coming out of the influent generator model (soluble COD, particulate COD, TKN and TP) into ASM2d state variables has been implemented in MSL as follows:

```

CLASS CODsp
  (* class = "transformer"; category = "" *) "a COD to ASM2(d) (Temp) influent
transformer"
  SPECIALISES PhysicalDAEModelType :=
{:
  comments <- "Transforms a COD influent to an influent type for ASM2(d) (Temp)";

  interface <-
  {
    OBJ Inflow (* terminal = "in_1" *) "Inflow" :
      InCODTerminal := {: causality <- "CIN" ; group <- "Influent" :};
    OBJ Outflow (* terminal = "out_1" *) "Outflow" :
      OutWWTPConcTerminal := {: causality <- "COUT" ; group <- "Effluent" :};
  };

  parameters <-
  {
    OBJ F_TSS_COD "Conversion factor TSS/COD" : Real := {: value <- 0.75 ; group
<- "Conversion factors" :};
    // used to calculate the remaining states
    // notice that they can be left zero in
    // most cases
    OBJ S_O_In "Constant concentration of dissolved oxygen in the influent":
    Concentration := {: value <- 0 ; group <- "Influent characterization" :};
    OBJ S_ALK_In "Constant concentration of alkalinity in the influent":
    Concentration := {: value <- 30 ; group <- "Influent characterization" :};
    OBJ S_NO_In "Constant concentration of nitrate in the influent": Concentration
:= {: value <- 0 ; group <- "Influent characterization" :};
    OBJ S_N2_In "Constant concentration of dinitrogen in the influent":
    Concentration := {: value <- 0 ; group <- "Influent characterization" :};
    OBJ X_PP_In "Constant concentration of poly-phosphate in the influent":
    Concentration := {: value <- 0 ; group <- "Influent characterization" :};
    OBJ X_AUT_In "Constant concentration of autotrophic biomass in the influent":
    Concentration := {: value <- 0 ; group <- "Influent characterization" :};
    OBJ X_PAO_In "Constant concentration of phosphate accumulating organisms in
the influent": Concentration := {: value <- 0 ; group <- "Influent
characterization" :};
    OBJ X_PHA_In "Constant concentration of cell internal organic storage products
of the PAO in the influent": Concentration := {: value <- 0 ; group <-
"Influent characterization" :};
    OBJ X_MEOH_In "Constant concentration of metal-hydroxides in the influent":
    Concentration := {: value <- 0 ; group <- "Influent characterization" :};
    OBJ X_MEP_In "Constant concentration of metal-phosphates in the influent":
    Concentration := {: value <- 0 ; group <- "Influent characterization" :};

    // fractions to calculate all remaining Outflows
    OBJ f_S_F "Fraction of fermentable readily biodegradable products (S_F) in the
soluble COD": Fraction := {: value <- 0.375 ; group <- "Conversion factors"
:};
    OBJ f_S_A "Fraction of fermentation products (S_A) in the soluble COD":
    Fraction := {: value <- 0.25 ; group <- "Conversion factors" :};
    OBJ f_X_S "Fraction slowly biodegradable substrate (X_S) in the particulate
COD" : Fraction := {: value <- 0.68 ; group <- "Conversion factors" :};
  }

```

## Appendix B

---

```
OBJ f_X_H "Fraction of heterotrophic biomass (X_H) in the particulate COD":
Fraction := {: value      <- 0.16 ; group <- "Conversion factors" :};

// Nitrogen and phosphorus fractions
OBJ i_N_S_I "Nitrogen content of inert soluble COD S_I" :
NitrogenConversionFactor := {:value <- 0.01 ; group <- "Composition
parameters" :};
OBJ i_N_S_F "Nitrogen content of soluble substrate S_F" :
NitrogenConversionFactor := {:value <- 0.03 ; group <- "Composition
parameters" :};
OBJ i_N_X_I "Nitrogen content of inert particulate COD X_I" :
NitrogenConversionFactor := {:value      <- 0.03 ; group <- "Composition
parameters" :};
OBJ i_N_X_S "Nitrogen content of particulate substrate X_S" :
NitrogenConversionFactor := {:value      <- 0.04 ; group <- "Composition
parameters" :};
OBJ i_N_BM "Nitrogen content of biomass X_H, X_PAO, X_AUT" :
NitrogenConversionFactor := {:value      <- 0.07 ; group <- "Composition
parameters" :};
OBJ i_P_S_I "Phosphorus content of inert soluble COD S_I" :
PhosphorusConversionFactor := {:value      <- 0.00 ; group <- "Composition
parameters" :};
OBJ i_P_S_F "Phosphorus content of soluble substrate S_F" :
PhosphorusConversionFactor := {:value      <- 0.01 ; group <- "Composition
parameters" :};
OBJ i_P_X_I "Phosphorus content of inert particulate COD X_I" :
PhosphorusConversionFactor :=      {:value <- 0.01 ; group <- "Composition
parameters" :};
OBJ i_P_X_S "Phosphorus content of particulate substrate X_S" :
PhosphorusConversionFactor :=      {:value <- 0.01 ; group <- "Composition
parameters" :};
OBJ i_P_BM "Phosphorus content of biomass X_H, X_PAO, X_AUT" :
PhosphorusConversionFactor :=      {:value <- 0.02 ; group <- "Composition
parameters" :};
};

independent <-
{
  OBJ t "Time" : Time := {: group <- "Time" :};
};

state <-
{
  OBJ S_NH_help (* hidden = "1" *) : Concentration;
  OBJ S_PO_help (* hidden = "1" *) : Concentration;
};

equations <-
{

//WATER
  interface.Outflow[H2O] = interface.Inflow[H2O] ;

// Oxygen and Alkalinity
  interface.Outflow[S_O] = parameters.S_O_In ;
  interface.Outflow[S_ALK] = parameters.S_ALK_In ;

// NITROGEN
  interface.Outflow[S_NO] = parameters.S_NO_In ;
```

```

interface.Outflow[S_N2] = parameters.S_N2_In ;
state.S_NH_help = interface.Inflow[TKN]
    - parameters.i_N_S_I * interface.Outflow[S_I]
    - parameters.i_N_S_F * interface.Outflow[S_F]
    - parameters.i_N_X_I * interface.Outflow[X_I]
    - parameters.i_N_X_S * interface.Outflow[X_S]
    - parameters.i_N_BM * (interface.Outflow[X_H] +
interface.Outflow[X_AUT] + interface.Outflow[X_PAO]);
    interface.Outflow[S_NH] = IF (state.S_NH_help > 0)
        THEN state.S_NH_help
        ELSE 0;

// PHOSPHOROUS

    state.S_PO_help = interface.Inflow[TP] - interface.Outflow[X_PP] -
interface.Outflow[X_MEP]
        - parameters.i_P_S_I * interface.Outflow[S_I]
        - parameters.i_P_S_F * interface.Outflow[S_F]
        - parameters.i_P_X_I * interface.Outflow[X_I]
        - parameters.i_P_X_S * interface.Outflow[X_S]
        - parameters.i_P_BM * (interface.Outflow[X_H] +
interface.Outflow[X_AUT] + interface.Outflow[X_PAO]); ;
    interface.Outflow[S_PO] = IF (state.S_PO_help > 0)
        THEN state.S_PO_help
        ELSE 0;
    interface.Outflow[X_PP] = parameters.X_PP_In ;

// COD
    interface.Outflow[S_F] = interface.Inflow[CODs] * parameters.f_S_F;
    interface.Outflow[S_A] = interface.Inflow[CODs] * parameters.f_S_A;
    interface.Outflow[S_I] = interface.Inflow[CODs] * (1 - parameters.f_S_F -
parameters.f_S_A) ;
    interface.Outflow[X_S] = interface.Inflow[CODp] * parameters.f_X_S;
    interface.Outflow[X_H] = interface.Inflow[CODp] * parameters.f_X_H;
    interface.Outflow[X_AUT] = parameters.X_AUT_In ;
    interface.Outflow[X_PAO] = parameters.X_PAO_In ;
    interface.Outflow[X_PHA] = parameters.X_PHA_In ;
    interface.Outflow[X_I] = interface.Inflow[CODp]
        - interface.Outflow[X_H]
        - interface.Outflow[X_AUT]
        - interface.Outflow[X_PAO]
        - interface.Outflow[X_PHA]
        - interface.Outflow[X_S];

    interface.Outflow[X_MEOH] = parameters.X_MEOH_In ;
    interface.Outflow[X_MEP] = parameters.X_MEP_In ;

//TSS
    interface.Outflow[X_TSS] = interface.Inflow[CODp] * parameters.F_TSS_COD
};
:};

```



## **APPENDIX C**

### **WWTP UPGRADE CONFIGURATIONS**



The figures that are shown in the following section to illustrate the upgraded layouts are simplified versions of the configurations that were implemented in WEST. For clarity, some blocks and connections were hidden (see Figure 175). The most important simplification to keep in mind is that the aerated tank is divided into six zones, although in most of the figures only one tank is shown. Other graphical simplifications are:

- in the input and output of the model, the blocks responsible for the conversion of concentrations to mass flows (“C/F”) and vice versa (“F/C”) have been omitted;
- the combined sewer overflow (“CSO”) has been omitted;
- the storm tank infrastructure is incorporated into a “coupled model” block, except for U12, in which the storm tank infrastructure is used as an ammonia peak load buffer;
- the controller block “c\_Qmin” responsible for assuring a minimal internal recycle and sludge recycle flow-rate has been omitted;
- the temperature input to all tanks has been omitted.

It is important to stress that these are only graphical simplifications. Obviously, the simulations were run using the complete configurations.

Concerning the configurations, DO is controlled in all of them by means of a PI controller implemented in MSL in the following code:

```

CLASS PI_DO
  (* class = "controller" *)
  "PI controller"
  // The value of the manipulated variabele changes proportional to the value
  // of the error signal and to the value of the integral of the error function
  // in time.
  SPECIALISES
  PhysicalDAEModelType :=
  {
    comments <- "A model for a proportional-integral controller";
    interface <-
    {
      OBJ y_M (* terminal = "in_1" *) "Sensor measured output" :
        Real := {: causality <- "CIN" ; group <- "Measurement data" :};
      OBJ u (* terminal = "out_1" *) "Controlled variable" :
        Real := {: causality <- "COUT" ; group <- "Control action" :};
    };
    parameters <-
    {
      OBJ u0 "No error action" : Real := {: value <- 50 ; group <- "Operational" :};
      OBJ y_S "Setpoint value for controlled variable" :
        Real := {: value <- 2 ; group <- "Operational" :};
      OBJ K_P "Factor of proportionality" :
        Real := {: value <- 25 ; group <- "Operational" :};
      OBJ T_I "Integral time" : Time := {: value <- 0.1 ; group <- "Operational" :};
    };
    independent <-
    {
      OBJ t "Time" : Time := {: group <- "Time" :};
    };
    state <-
    {

```

## Appendix C

---

```
OBJ e "Error" : PhysicalQuantityType := {: group <- "Operational" :};
OBJ Integ_e "Integral of error" : PhysicalQuantityType := {: group <-
"Operational" :};
  OBJ u_help (* hidden = "1" *) : Real;
};
equations <-
{
{state.e = parameters.y_S - interface.y_M;};
{DERIV(state.Integ_e,[independent.t]) = state.e;};
{state.u_help = parameters.K_P *
(state.e + (1 / parameters.T_I) * state.Integ_e) +
parameters.u0;};
  interface.u = IF (state.u_help > 0)
                  THEN state.u_help
                  ELSE 0;
};
:};
```



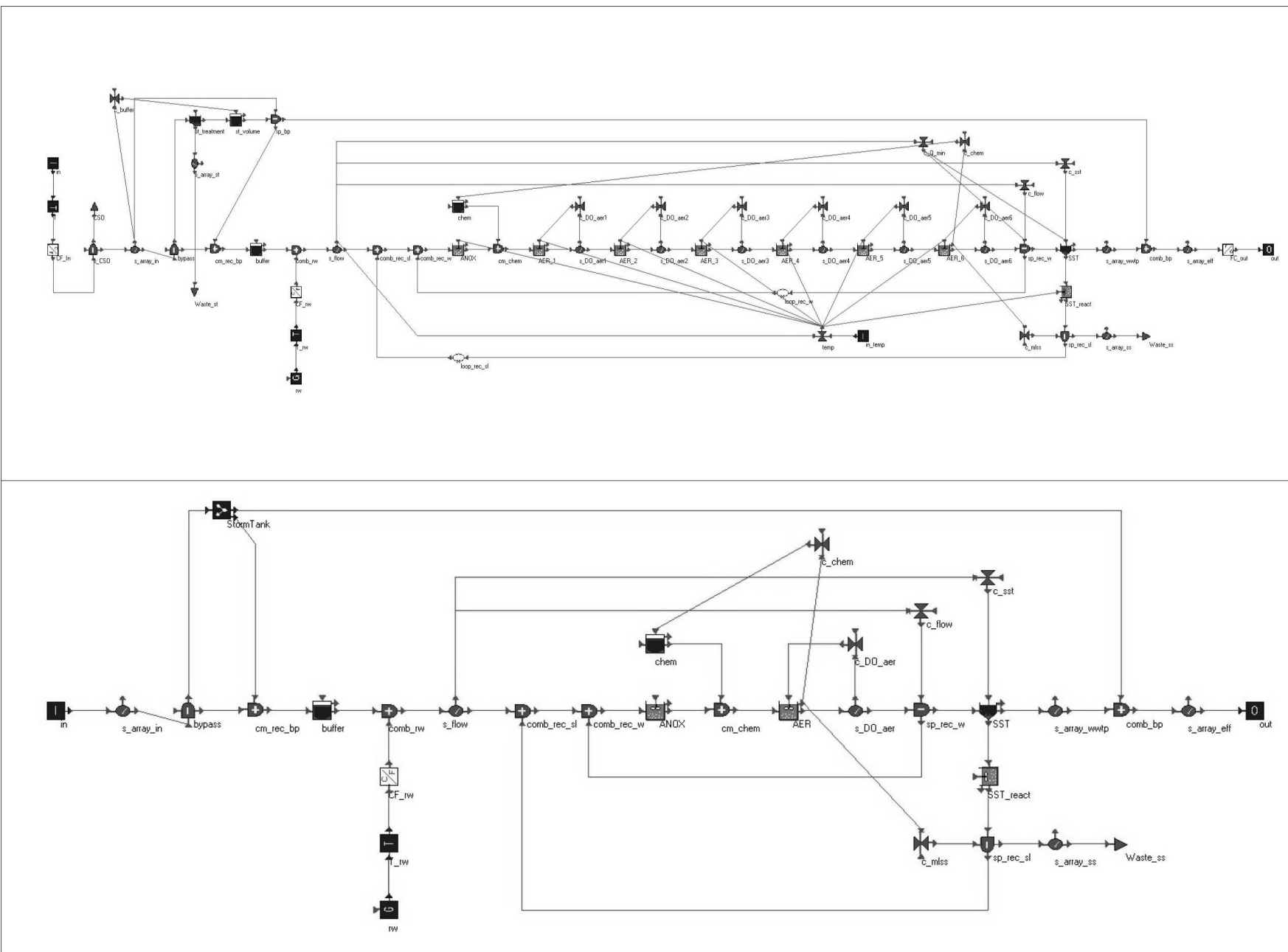

Figure 175: Complete LLAS configuration (left) and simplified representation (right).

## U1

### INCREASE OF AERATED TANK VOLUME BY 33%

The process which is more prone to failure caused by an increase in plant loading is nitrification. Autotrophic bacteria require a minimum solids retention time (SRT) to perform stable nitrification, higher with low temperature. This means that in order to assure effluent ammonia and total nitrogen below the limits, one option is to increase the aerated volume. In this case, the same increase as the load has been applied (33%).

## U2

### U1 + INCREASE OF FINAL CLARIFIER AREA BY 33%

Even if the settling volume of the dimensioning for 300,000PE was sufficient to avoid sludge losses also in the case of 400,000PE influent, an increase of 33% of settling surface (keeping the settler depth constant to 4m) has been applied in addition to U1. This to decrease the hydraulic stress in the settler, which was causing risky sludge blanket heights in rain periods and to increase the sludge quantity in the system which increases the SRT and therefore improves nitrification.

## U3

### U1 + PRE-ANAEROBIC TANK + C DOSAGE TO DENITRO + LOWER DO SET-POINT

For this upgrade, the addition of an anaerobic tank before the anoxic tank (see Figure 176) to promote biological phosphorous removal has the purpose of reducing the consumption of the chemical P-precipitant. The consumption of readily biodegradable COD by such a tank prevents denitrification to be fully performed; therefore the addition of carbon in the anoxic tank is necessary. For this example, a 9% solution of acetic acid was chosen as the carbon source. The COD content (modelled as S<sub>F</sub>) is assumed to be 96.3g/l, associated with a cost of 0.70€/l. In order to reduce the aeration costs, the set-point for DO in the aerated tanks is lower than the one used in the other LLAS configurations (1mg/l instead of 1.5mg/l).

For the C-source dosage:

P controller with upper and lower limits

Input = NO<sub>3</sub>-N concentration in anox tank

Output = flow-rate of C-source (m<sup>3</sup>/d)

set-point 1 mg/l NO<sub>3</sub>-N

K<sub>P</sub> = -100

u<sub>lower</sub> = 0

u<sub>upper</sub> = 100

u0 = 12

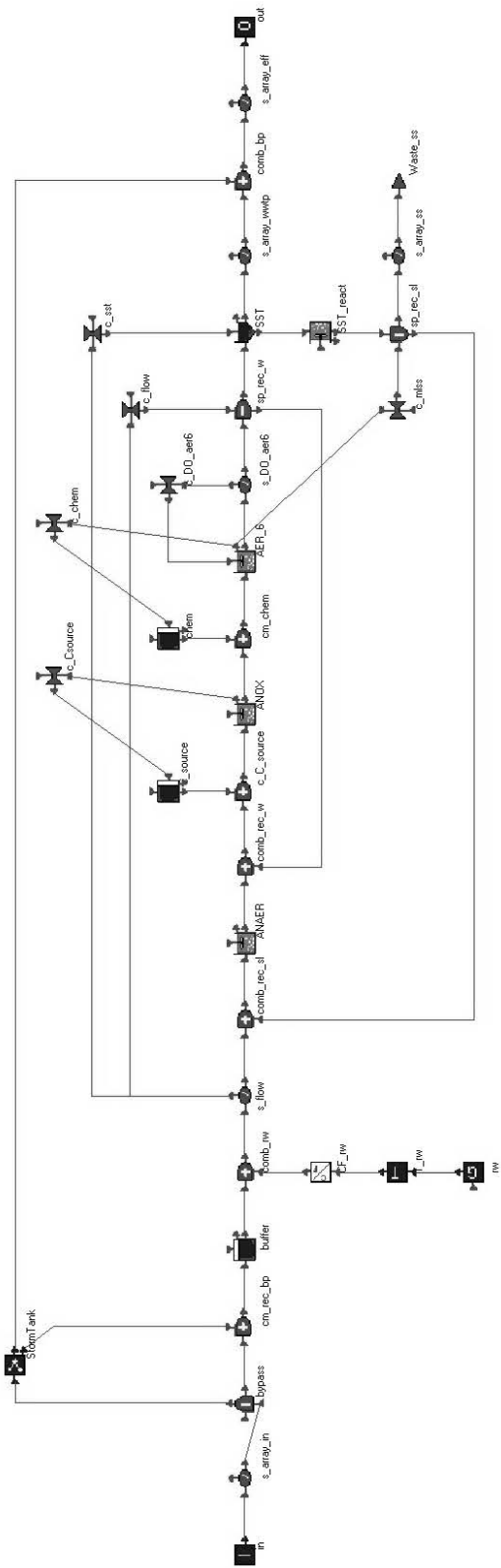

Figure 176: Configuration with a pre-anaerobic tank and dosage of external carbon source based on nitrate measurements in the anoxic tank.

## U4

### DOSAGE OF EXTERNAL CARBON SOURCE

Denitrifying micro-organisms use nitrate as a source of electrons when they are kept under anoxic conditions. By having an anoxic tank in a WWTP, this capability is exploited to convert nitrate (which has been produced out of ammonia by nitrifying organisms) into nitrogen gas. The electron acceptor in the process is a readily biodegradable carbon source. In WWTP configurations where (part of) the influent is fed to an anoxic tank, the influent COD is used as a carbon source. When this influent COD content is insufficient for complete denitrification, an external carbon source like methanol, ethanol, acetic acid, etc. can be added to the anoxic tank.

Adding too much carbon can lead to excessive sludge production, worse BOD effluent and unnecessary costs. With real time control, the addition of this external carbon source can be regulated according to the needs for complete denitrification. In this upgrade scenario, feedback control is applied (Figure 177). The observed variable is the nitrate concentration in the anoxic tank. The manipulated variable is the flow rate of the external carbon source dosage device. Feedback control is carried out by a simple P-controller with a set-point of  $1\text{mgNO}_3\text{-N/l}$ . This set-point was chosen according to Yuan *et al.* (1997). For this particular example, a 9% solution of acetic acid was chosen as the carbon source. The COD content (modelled as  $S_F$ ) is assumed to be  $96.3\text{g/l}$ , associated with a cost of  $0.70\text{€/l}$ .

In literature, other and more sophisticated control strategies can be found. Samuelsson (2005) compared a PI feedback controller with a combined feed-forward/feedback controller. Lindberg and Carlsson (1996) studied adaptive control, Carlsson and Milocco (2001) simulated linearising control.

The controller for C dosage is the same as for U3.

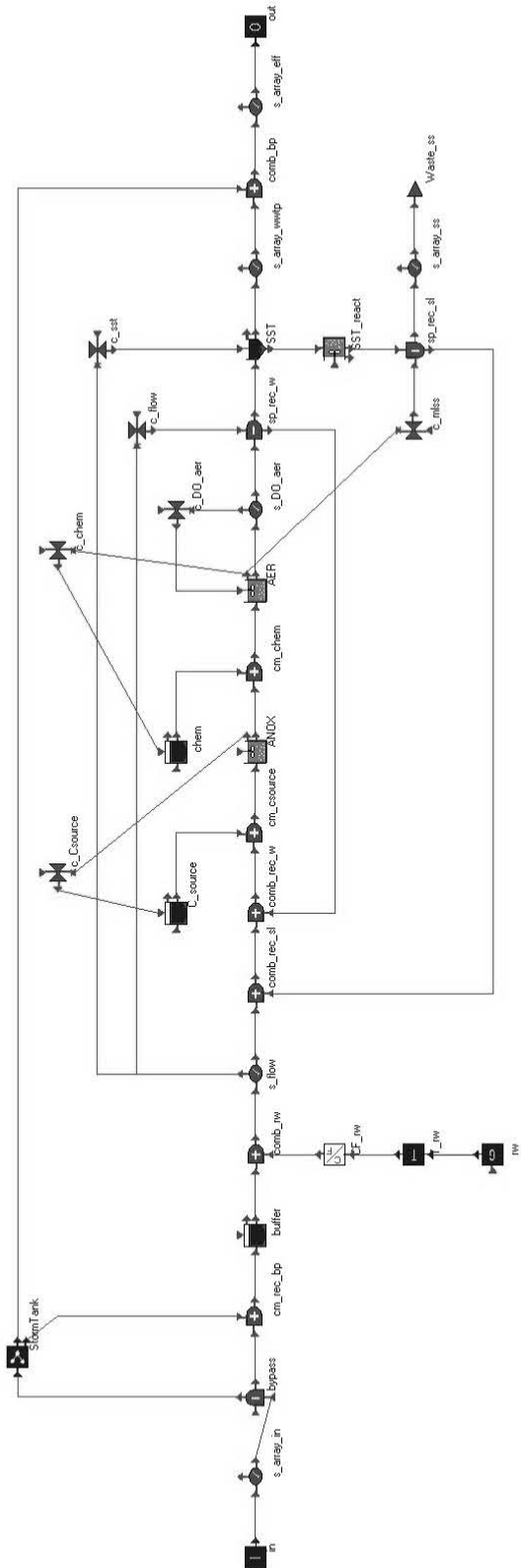

Figure 177: Configuration with dosage of external carbon source based on nitrate measurements in the anoxic tank

## U5 DO CONTROL BASED ON AMMONIA

In the base scenario, DO control in the aerated tanks is achieved by a PI controller with a fixed set-point. The observed variable is the DO concentration in the effluent of the tank. The controller output is the  $K_La$  value which is fed to the aeration equipment. The desired DO concentration was set to 1.5mg/l for the first 5 compartments and 1mg/l for the last compartment.

The idea behind this RTC upgrade option is that aeration costs can be reduced by lowering the DO set-points whenever the effluent ammonia concentration is below a certain threshold. Since nitrification of ammonia is a slower process than COD removal, it is the determining factor in estimating aeration needs (Olsson and Newell, 1999). Therefore effluent COD concentrations will not be harmed significantly by reducing aeration. Besides saving money by decreasing the DO set-point when the effluent ammonia concentration is low, it is also possible to improve effluent quality by increasing aeration (and nitrification) when high ammonia concentrations are observed.

A scheme of the implemented RTC upgrade is shown in and Figure 179. Aeration is controlled by a cascade P/PI control mechanism. The ammonia concentration in the effluent of the last aerated tank is kept at a desired level of 1.7mg/l by a supervisory P controller (master) that determines the set-points of the DO controllers (slaves) in each of the 6 aerated tanks. To avoid bulking sludge caused by insufficient aeration, the master controller's output was limited to a certain range of values. The upper boundary was set to 4mgDO/l, the lower boundary to 1mgDO/l. This lower boundary was allowed to be reduced to 0mgDO/l only in case the daily averaged DO concentration was higher than 1mgDO/l. To reduce the amount of DO in the mixed liquor that is recycled to the anoxic tank, the DO set-point in the last aerated tank is set lower than the others.

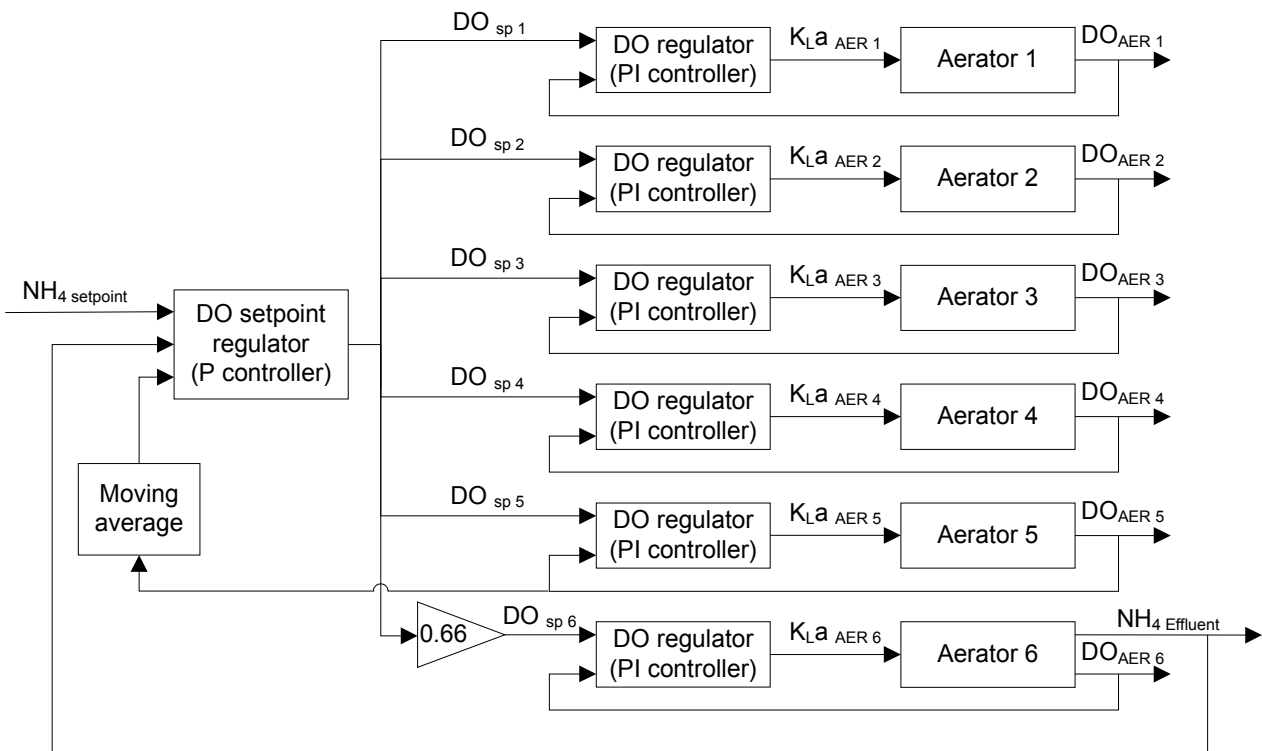

Figure 178: Scheme of the cascade DO control implemented in U5.

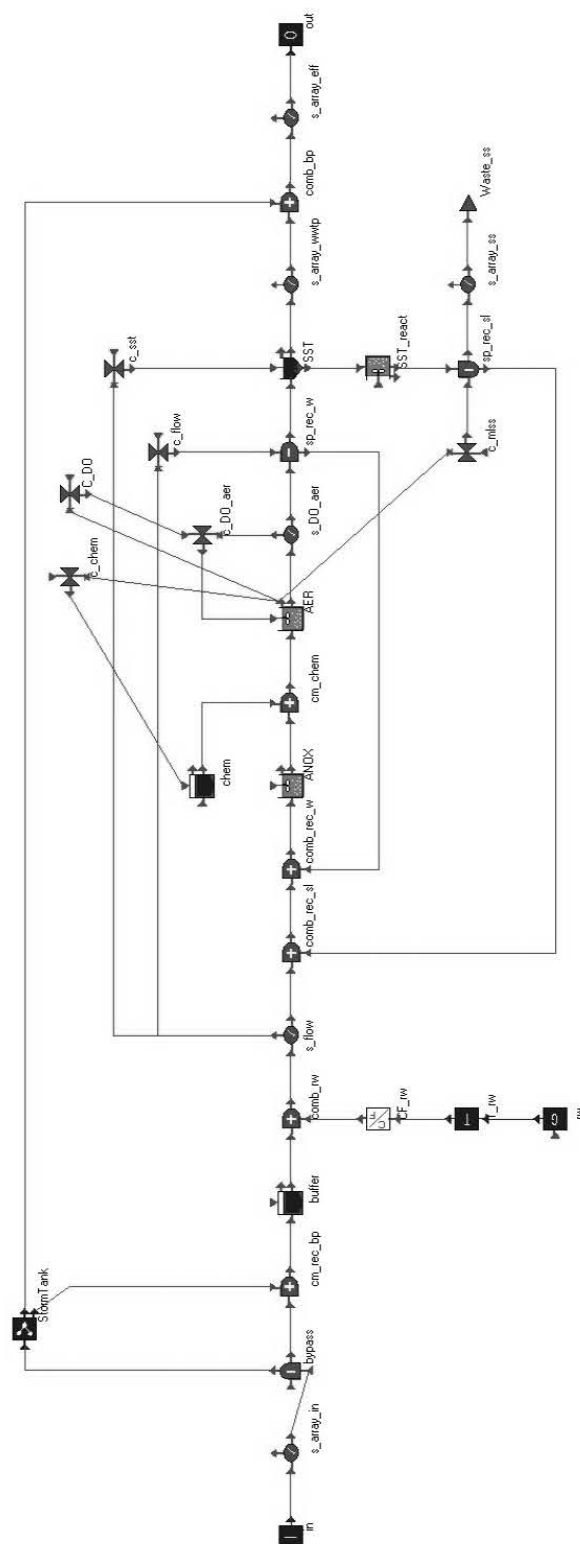

Figure 179: Configuration with cascade DO control based on measurements of ammonia, DO and a moving average of the DO measurement.

Ingildsen (2002) pointed out that the performance of this type of control in terms of disturbance rejection is much better when the ammonium sensor is placed in the effluent of the last aerated tank than when it is placed in the effluent of the secondary settler, due to serious delays. Nevertheless, in case the plant is already equipped with on-line nutrient sensors in the effluent and it is found to be a too high cost to install an extra ammonium sensor in the last aerated tank, this information could still be used for control. In this case a slow integral controller, also called a floating controller, should be used. It will keep the long term average ammonia concentration at the desired value by slowly changing the DO set-point. Like this, a good trade-off between effluent quality and aeration costs can be reached with the means that are available.

Suescun *et al.* (2001) used this cascaded control strategy with a 24h moving average applied on the effluent ammonia measurements.

In Kayser (1990), an early German example of ammonia based aeration control can be found. Aeration capacity is switched on or off according to a hysteresis mechanism: if the effluent ammonia concentration drops below  $1\text{mgNH}_4\text{-N/l}$ , air supply is reduced until the level of  $3\text{mgNH}_4\text{-N/l}$  is reached. Similar to this, extra aeration capacity is switched on if the ammonia concentration exceeds  $8\text{mgNH}_4\text{-N/l}$  and remains on until  $3\text{mgNH}_4\text{-N/l}$  is reached.

Ingildsen (2002) simulated the behaviour of an *in situ* FFFB controller (combination of feed-forward and feedback). This involves a measurement of the ammonia concentration in the effluent of the last aerated tank (feedback) combined with measuring the ammonia load entering the aerated tanks (feed-forward). Simulations showed that a slightly better disturbance rejection can be achieved at the cost of higher aeration energy consumption. However, this was contradicted during full-scale experiments.

Also in Ingildsen *et al.* (2002) a combination of feed-forward and feedback control can be found. In this case, ammonia is treated as a tracer. A simple hydraulic model is used to predict the propagation of ammonia peak loads through the different aerated tanks. This feed-forward information is used to determine the needed aeration intensity in the different aerators. The controller parameters are updated based on feedback data resulting from an ammonia sensor in the effluent of the secondary settler.

Concerning the implementation of the controllers:

DO set-point regulator:

P-controller with upper and lower limits

$u_0 = 1$  for Mediterranean and  $0.5$  for Continental

$u_{\text{upper}} = 4$

$u_{\text{lower}}$  in case  $y_{\text{M\_av}} < 1 = 1$

$u_{\text{lower}}$  in case  $y_{\text{M\_av}} > 1 = 0$

$K_P = -15$  for Mediterranean and  $-10$  for Continental

set-point:  $1.7$

Algorithm:

```
state.u_help = parameters.K_P * (parameters.y_S - interface.y_M) +
parameters.u0;
interface.u = IF (state.u_help > parameters.u_upper)
    THEN parameters.u_upper
    ELSE
    IF (state.u_help > parameters.u_lower_1)
```



```

THEN state.u_help
ELSE // controller wants to go lower than limit
// only possible when y_M_av > y_M_av_min
  IF (interface.y_M_av < parameters.y_M_av_min)
    THEN parameters.u_lower_1
  ELSE
    IF (state.u_help < parameters.u_lower_2)
      THEN parameters.u_lower_2
    ELSE state.u_help;

```

“moving average”: output is first order behaviour of input signal, with certain time constant tau:

```

DERIV(state.u_help, [independent.t]) = ((interface.y_M - state.u_help) /
parameters.tau) ;
interface.u = state.u_help;

```

here tau = 1 (day)

## U6 INTERNAL RECYCLE CONTROL BASED ON NITRATE

In the LLAS configuration, mixed liquor is recycled from the last aerated tank to the anoxic tank (Figure 180). The nitrate that has been formed during nitrification in the aerated tanks is in this way fed to the denitrifying organisms in the anoxic tank while they can make use of the influent COD as a carbon source.

In the basic LLAS configuration, the flow rate of this internal recycle is set proportional to the influent flow rate. To optimise the use of the denitrification potential, it would be better to control the internal recycle flow rate based on an on-line measurement of the nitrate concentration in the effluent of the anoxic tank. Therefore a nitrate sensor is placed at the end of the anoxic zone and a proportional feedback controller is used to keep this nitrate concentration at a constant level by varying the internal recycle flow rate, with a maximum of 8 times the yearly average influent flow.

In literature, NO<sub>3</sub>-N set-points between 1 and 2mg/l can be found (Gernaey and Jorgensen, 2004; Yuan and Keller, 2003; Yuan *et al.*, 2002). Simulations showed that applying a set-point of 2mg/l requires a too high recirculation rate, also implying the recycle of quite some DO to the anoxic tank, which is not favourable. For these reasons a set-point of 1 mg/l at the outlet of the anoxic zone was used.

Ingildsen (2002) simulated this type of control with a PI-controller and compared its performance with the one of the ratio controller. Based on the total nitrogen concentration in the effluent, the stationary simulations show only a slight advantage of the first strategy, but the author points at other benefits. Effluent quality is less sensitive to the choice of the set-point in case of a P(I)-controller than to the choice of the ratio in case of a ratio controller. The determination of the optimal ratio is case dependant, while it is known that the system is controlled close to optimality when using the nitrate set-point strategy. This last control strategy can also deal with fluctuating nitrate loads, COD loads or denitrification rates. Due to windup problems in/after wintertime, a proportional controller was used for the evaluation of this upgrade option instead of a proportional-

integral controller.

Other control strategies include the adaptation of the internal recycle rate to the influent bCOD load (e.g. Longdon, 1992). Yuan *et al.* (2002) pointed out that this strategy is not as robust as imposing a constant nitrate concentration in the anoxic tank. Also the on-line measurement of bCOD is not straightforward.

The basic LLAS configuration had a maximum internal recycle flow rate of 7 times the yearly average influent flow, while the studied RTC upgrade allows for a maximum of 8 times the yearly average influent flow. It was noticed that the benefits of this upgrade were not only due to the use of a nitrate proportional flow rate controller instead of a ratio controller, but also due to the increase of the maximum flow rate from 7 to 8 times the yearly influent flow rate. To have a better base for comparison, two additional scenarios were simulated: a) the original configuration with a maximum flow rate of 8 times the yearly average influent flow and b) installing a fixed flow recirculation pump instead of a variable flow pump. Note that this last scenario in fact means that there is no control applied at all. The fixed flow rate was set to 6 times the yearly average influent flow, which is about 10% higher than the average recirculation flow rate in the original configuration.

The controller was implemented as follows:

P controller with upper and lower limits

Input = NO<sub>3</sub>-N concentration in anoxic tank

Output u is flow-rate in m<sup>3</sup>/d

K<sub>P</sub> = 500000

u<sub>upper</sub> = 669845

set-point = 1

u<sub>lower</sub> = 0

u<sub>0</sub> = 450000

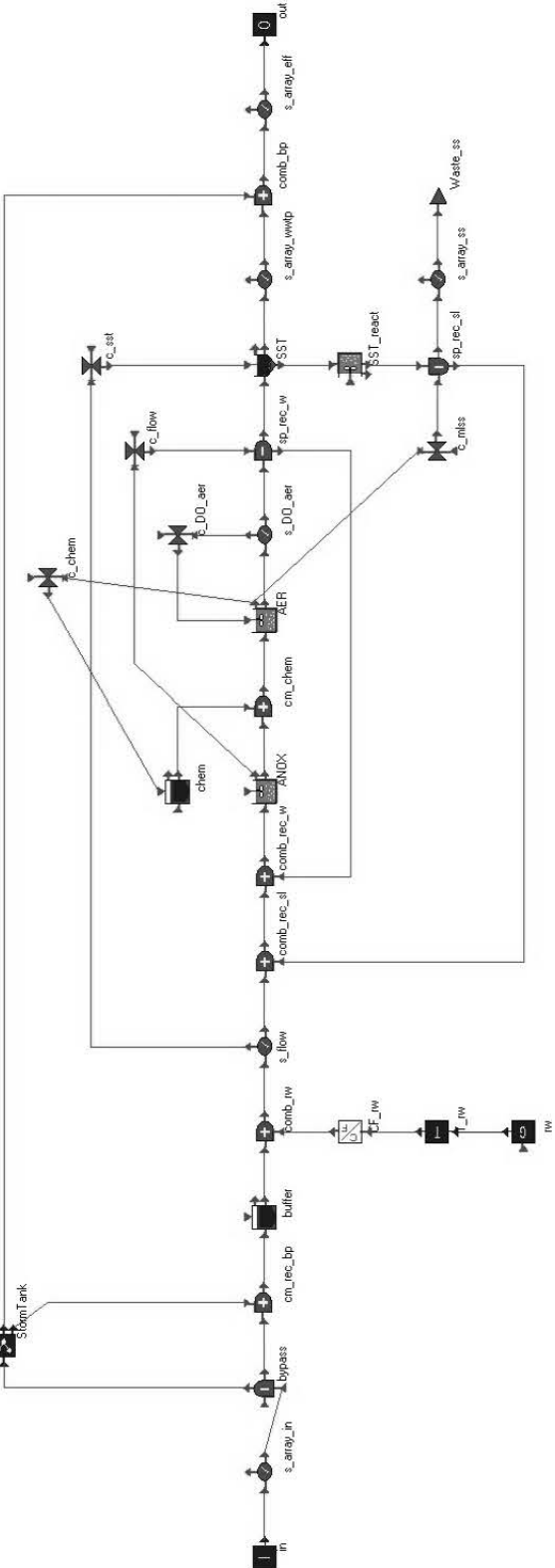

Figure 180: Internal recycle control configuration based on a nitrate measurement in the anoxic tank.

## U7

### U4 + U6

U4 (external carbon source dosage) and U6 (internal recirculation control) are both based on denitrification in the anoxic tank. Because the addition of external carbon is much more expensive than modifying the internal recycle flow rate, it is important to exploit upgrade option U6 to the maximum extent before making use of upgrade option U4.

Attention has to be given to the possibility that both systems can stimulate each other. By adding external carbon, denitrification is enhanced. This causes the  $\text{NO}_3\text{-N}$  concentration to drop below the set-point of  $1\text{mg/l}$ , which results in an increase of the internal recycle rate because this controller optimises the use of the available carbon, regardless if it stems from the influent or from an external source. As long as the biomass can keep up with this raising nitrate and carbon influx, denitrification is enhanced. This can lead to an expensive form of over-compliance.

The two control strategies can be coupled in several ways. Ingildsen (2002) simulated the behaviour of two independent feedback loops: internal recycle control based on measurements of nitrate at the end of the anoxic tank and carbon dosage control based on total inorganic nitrogen measurements at the outlet of the aerobic reactors. Yuan and Keller (2003) proposed a control structure with four PID controllers. The system has a “low-load controller” part that only uses internal recycle and a “high-load controller” part that allows both internal recycle and carbon dosage. A relay switches between the two control loops, based on the nitrate concentration in the anoxic tank and two effluent nitrate set-point values: an instant and a long term average discharge limit.

Peng *et al.* (2005) applied the same control structure, but with fuzzy controllers instead of PID controllers and a measurement of the ORP instead of the nitrate concentration at the end of the anoxic zone. In fact, the structure used by Yuan and Keller (2003) and Peng *et al.* (2005) is based on the same principle as the one applied by Ingildsen (2002), but extended with a decision making system to switch off carbon addition when effluent standards can be met using only internal recirculation.

The control structure evaluated in this upgrade option (Figure 181) uses the same proportional controller for the internal recycle flow rate as was used in upgrade U6. It adjusts the recycle flow rate in order to keep the nitrate nitrogen concentration in the anoxic tank at a constant set-point of  $1\text{mgNO}_3\text{-N/l}$ . Carbon source dosage is controlled by a proportional controller like in upgrade U4, also with a set-point of  $1\text{mg/l}$ , but it is switched on only if the total inorganic nitrogen concentration in the effluent of the last aerated tank exceeds the limit of  $10\text{mg/l}$  of TN.

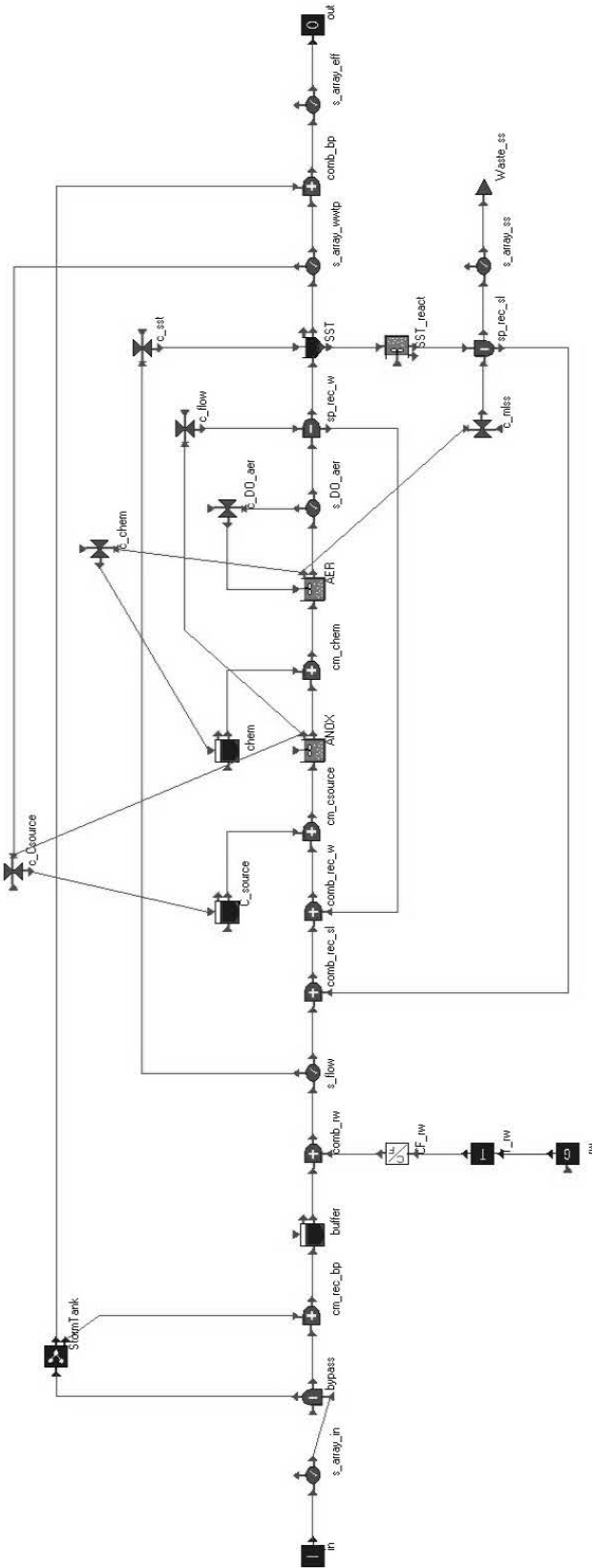
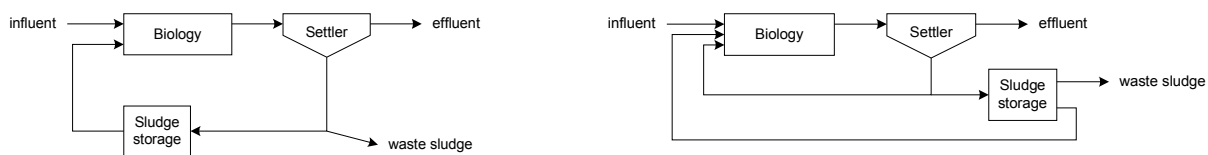

Figure 181: Configuration used in U7, where internal recycle control and external carbon source dosage are coordinated.

## U8 SPARE SLUDGE STORAGE

One way to have spare nutrient and COD removal capacity is to store sludge in a spare sludge tank. When needed, in case of high nitrogen loads or toxicity incidents, this spare biomass can be added to the system to increase its performance. The spare sludge tank can be installed in two ways: either in the recycle sludge loop (A in Figure 182), as is the case in contact stabilisation methods, or outside this loop (B in Figure 182). Yuan *et al.* (2000) pointed out that the second configuration is more suited for the aim of maintaining a spare biomass capacity than the first one.



A. Configuration with sludge storage tank in the sludge recycle loop.

B. Configuration with a sludge storage tank in the sludge waste flow.

Figure 182: Possible positions for a spare sludge storage tank.

The sludge retention time (SRT) of configuration B operating under normal conditions is not changed relative to the original configuration; whereas the SRT is prolonged in case A. This implies that not only biomass but also inert solids build up in the system to a greater extent in case A than in case B. Yuan *et al.* (1998) emphasised this point as a means to reduce the safety margins used in the design stage of a plant. It was also stressed that the advantage of the design vanishes if the biomass in the storage tank is used too frequently. Sufficient time should be provided for the plant to settle to its steady state after the stored sludge has been used. This is said to take two to three storage tank SRTs.

Obviously, the question rises on which strategy should be applied to control the spare sludge use. In this upgrade scenario, three alternatives were evaluated. The general upgrade layout is given in Figure 183.

The first decision mechanism is based on the ammonia load that is entering the treatment plant. From Figure 184 it can be concluded that this variable is well correlated with the ammonia concentration in the effluent. The implementation of this control strategy requires only an on-line ammonia measurement in the influent. The ammonia load to the plant can be derived from this concentration measurement and actual flow rate knowledge. Of course also the construction of a sludge storage volume and the necessary piping and pumping equipment are involved in the implementation of the upgrade, but that applies as well to the two other control strategies that are evaluated in this section.

The second sludge addition control strategy that was evaluated is based on the detection of influent ammonia peak loads. For this purpose, a 'peak' is defined as a load that is at least 50% higher than the average ammonia load of the last five days (illustrated in Figure 185).

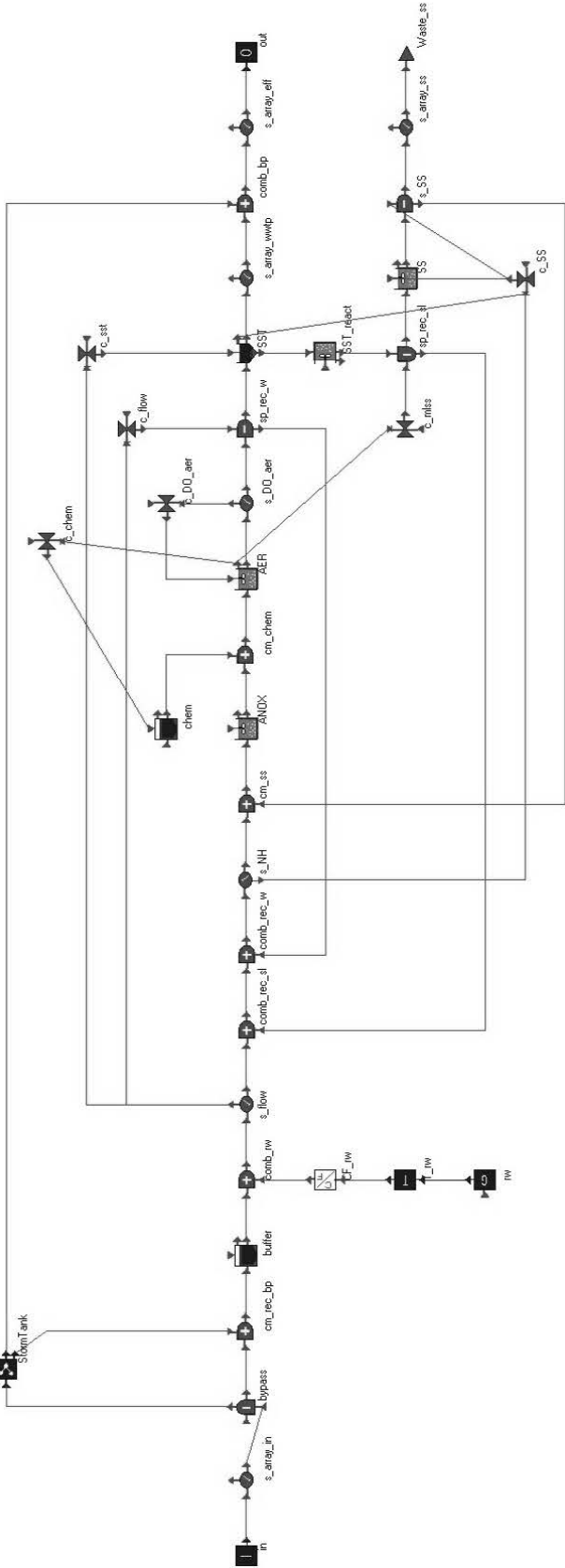

Figure 183: Configuration used in U8, with a spare sludge storage tank and a spare sludge recycle line.

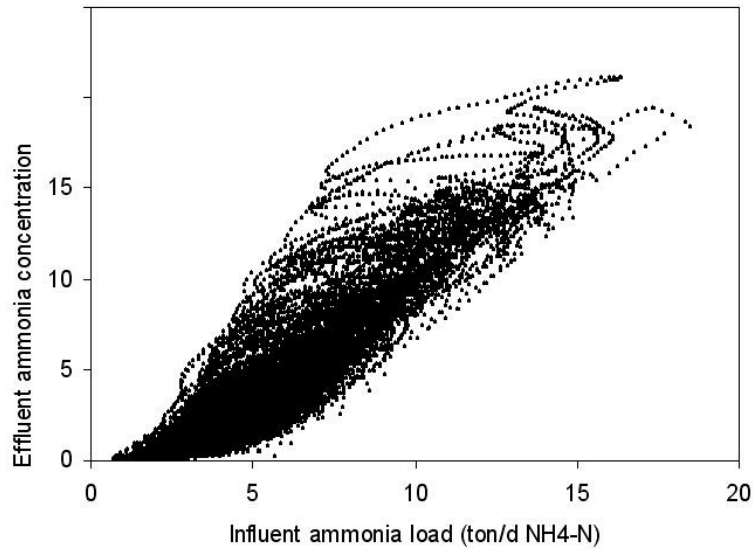

Figure 184: Effluent ammonia concentration as a function of influent ammonia load. The data were taken from a one year simulation of the not upgraded LLAS plant.

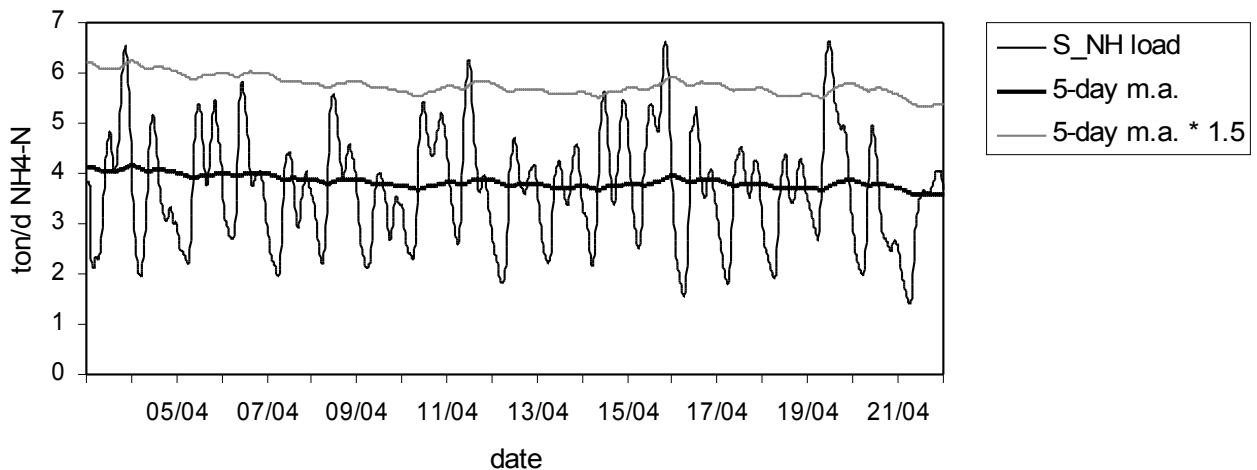

Figure 185: Illustration of ammonia peak load detection based on the five day moving average load. In this example there are four peaks detected. Data taken from simulation with Mediterranean climate influent, from April 4<sup>th</sup> to 22<sup>nd</sup>.

The third strategy is somewhat more sophisticated and makes use of an estimation of the potential nitrification capacity of the system. In practice, this maximal ammonia oxidation rate ( $r_{NHmax}$ ) could be derived from respirometric measurements (Spanjers *et al.*, 1998). In such experiments, a pulse of ammonia is injected into the respirometer which contains a sample of sludge. From the registered DO profile, a sudden drop in respiration rate can be deduced, revealing the ammonia being exhausted. The maximum nitrification rate can easily be estimated based on this information and some of the experiment parameters. In most cases, automated batch respirometer tests (or so-called in-sensor-experiments) are performed to have an updated value of the  $r_{NHmax}$  at regular time intervals, e.g. every 6 hours (Brouwer *et al.*, 1998). Also flow-through respirometer



tests were developed, although the determination of kinetic parameters such as  $r_{NHmax}$  is still based on a batch evaluation of the measured DO profile in the respirometer (Spérandio and Queinnec, 2004).

An alternative for respirometry is titrimetry (Gernaey *et al.*, 1997). As the nitrification process has an acidifying effect, an automated titration with base can be used to determine the endpoint of the nitrification period by detecting a change of slope in the titration curve, analogous to the change of slope in the oxygen uptake rate curve used in respirometry.

The incorporation of a modelled respirometer in the used LLAS configuration would imply the implementation of an automated strategy to register and evaluate batch DO profiles, which is beyond the scope of this deliverable. Therefore, the respirometer was considered to be a sensor providing information about the maximal nitrification capacity in the system. In this document, the estimation of  $r_{NHmax}$  is not based on some modelled respirometer, but on the nitrification equation:

with

$$\frac{d(S_{NH})}{dt} = -\frac{1}{Y_{AUT}} \cdot \mu_{AUT} \cdot \theta_{\mu_{AUT}}^{(T-T_{ref})} \cdot \sum_{i=1}^{\#tanks} \left( \frac{C_{DO,i}}{C_{DO,i} + K_{DO,AUT}} \cdot X_{AUT,i} \cdot V_i \right)$$

$S_{NH}$  = ammonia concentration (gNH<sub>4</sub>-N)

$Y_{AUT}$  = yield of autotrophic biomass (gCOD/gN)

$\mu_{AUT}$  = maximum growthrate of autotrophic organisms (1/d)

$\theta_{\mu_{AUT}}$  = temperature dependancy of  $\mu_{AUT}$

$T$  = actual temperature in aerated tanks (°C)

$T_{ref}$  = reference temperature at which  $\mu_{AUT}$  is determined (°C)

$C_{DO,i}$  = DO concentration in aerated tank  $i$  (gO<sub>2</sub>/m<sup>3</sup>)

$K_{DO,AUT}$  = saturation coefficient for DO (gO<sub>2</sub>/m<sup>3</sup>)

$X_{AUT,i}$  = autotrophic biomass in aerated tank  $i$  (gCOD/m<sup>3</sup>)

$V_i$  = volume of tank  $i$  (m<sup>3</sup>)

Based on this nitrification capacity in the system and an on-line measurement of the influent ammonia load, it is calculated what the effluent ammonia concentration would be. Together with a pre-set effluent ammonia set-point, this prediction is the basis for the decision mechanism that determines the spare sludge addition needs.

In reality, the amount of autotrophic biomass in the aerated part of the system is hard to measure on-line, but as mentioned above, this nitrification equation is only used in the model to generate the information that would in practice be provided by respirometry.

In the three cases, pumping of spare sludge was simulated with a fixed flow pump (5000m<sup>3</sup>/d), so the controllers act as automated on/off switches. To be sure that the addition of spare sludge to the system would not lead to washout of solids from the secondary settler, a feedback mechanism was built in that blocks spare sludge addition in case the sludge blanket height in the secondary settler exceeds a certain threshold value (80% of the settler height). The spare sludge tank was simulated as an activated sludge unit with a maximum volume of 2500m<sup>3</sup> and an aeration pattern of 60 minutes without aeration alternated with 15 minutes with aeration with a KLa of 100d<sup>-1</sup>.

## U9 SLUDGE WASTAGE CONTROL

In the original configuration, sludge wastage is controlled by a feedback mechanism that keeps the TSS concentration in the effluent of the last aerated tank at a set-point value of 3.5gTSS/l during summer (defined as the period with mixed liquor temperature above 16°C) and 4.5gTSS/l in wintertime (to have a higher sludge age). Instead of maintaining these fixed set-points, this upgrade option evaluates the possible benefits of a cascade control structure where the TSS set-point is determined on the basis of the ammonia concentration in the effluent of the last aerobic tank (see Figure 187).

When this concentration rises, it can be assumed that the nitrifying biomass in the aerators is not sufficient for complete nitrification and sludge wastage should be ceased in order to increase the solids concentration in the plant. To avoid sludge washout problems, the sludge blanket height in the secondary settler is monitored. The controller action is summarised in the decision tree shown in Figure 186. In contrast with the original configuration, the sludge wastage flow rate is adjusted by the controller every hour instead of once per day, which was the simulation of a plant operator adjusting the wastage flow rate manually every day.

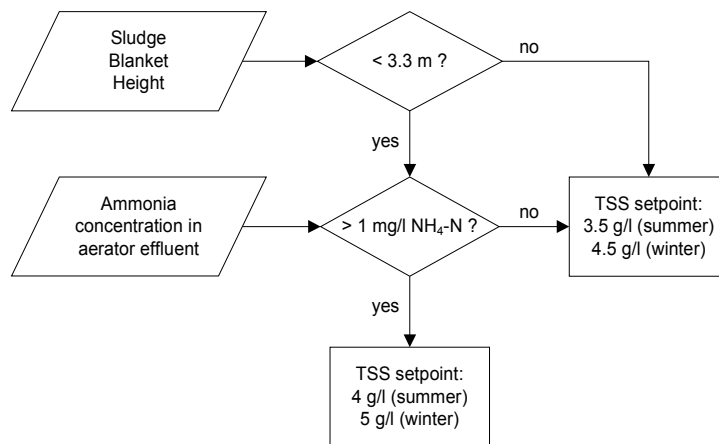

Figure 186: Decision tree for the master controller to determine the TSS set-point for the slave controller.

## U10 DYNAMIC STEP FEED

Step feed is the re-routing of (part of) the influent to a tank different from the first one in the sequence. Reasons for applying step feed in activated sludge systems are generally one of the following:

- decreasing the hydraulic loading of the settler during storm conditions;
- minimising the damage caused by toxic influents;
- optimizing organic carbon utilization for denitrification by distributing the influent bCOD more equally over different anoxic tanks.

Because washout of sludge from the final clarifier is not a problem in the studied plant set-up, the first motive was not considered. Neither was the second one: toxicity events are not included in the used dynamic influent data.

During winter, nitrification suffers from low temperatures, what results in higher effluent ammonia concentrations and lower effluent nitrate concentrations. At higher temperatures in summer, the limiting process in nitrogen removal is rather denitrification. The idea behind this upgrade scenario is mainly to save money by switching off aeration in the first of the six aerators during summertime, so the anoxic volume is enlarged. To spread the influent COD more equally over this enlarged denitrification volume, dynamic step feed is applied (Figure 188).

The fraction of influent that is step fed, is determined by a proportional feed-forward controller, based on an estimation of the carbon consumption in the first anoxic tank, which is proportional to the amount of nitrate that is converted into nitrogen gas. Two nitrate sensors, before and after the first anoxic tank, are installed to provide the needed information. Also a constructional intervention is necessary to divert part of the influent to the second tank. In most plant layouts, this can happen gravitationally and will not involve pumping equipment. A valve with adjustable flow rate and maybe some piping is sufficient. For the cost calculations in this document, a gravitational bypass feature is assumed.

About the implementation of the controller:

it is a simple P controller, but with lower and upper limits and with the property that it only works in certain time periods (i.e. in summer).

```
state.u_help = parameters.K_P * (state.y_M_before_help - state.y_M_after_help);
state.t_help = independent.t;
interface.u = IF ((state.t_help > parameters.t1) && (state.t_help <
parameters.t2)) ||
                (state.t_help >= parameters.t3))
    THEN
        IF (state.u_help > parameters.u_lower)
            THEN
                IF (state.u_help > parameters.u_upper)
                    THEN (parameters.u_upper * parameters.influent_flow_rate)
                    ELSE (state.u_help * parameters.influent_flow_rate)
            ELSE (parameters.u_lower * parameters.influent_flow_rate)
        ELSE 0;
```

state.u\_help, parameters.u\_upper and parameters.u\_lower = fractions of the influent flow-rate

interface.u = the flow-rate that should be bypassed

parameters.u\_upper = 0.5

parameters.u\_lower = 0.05

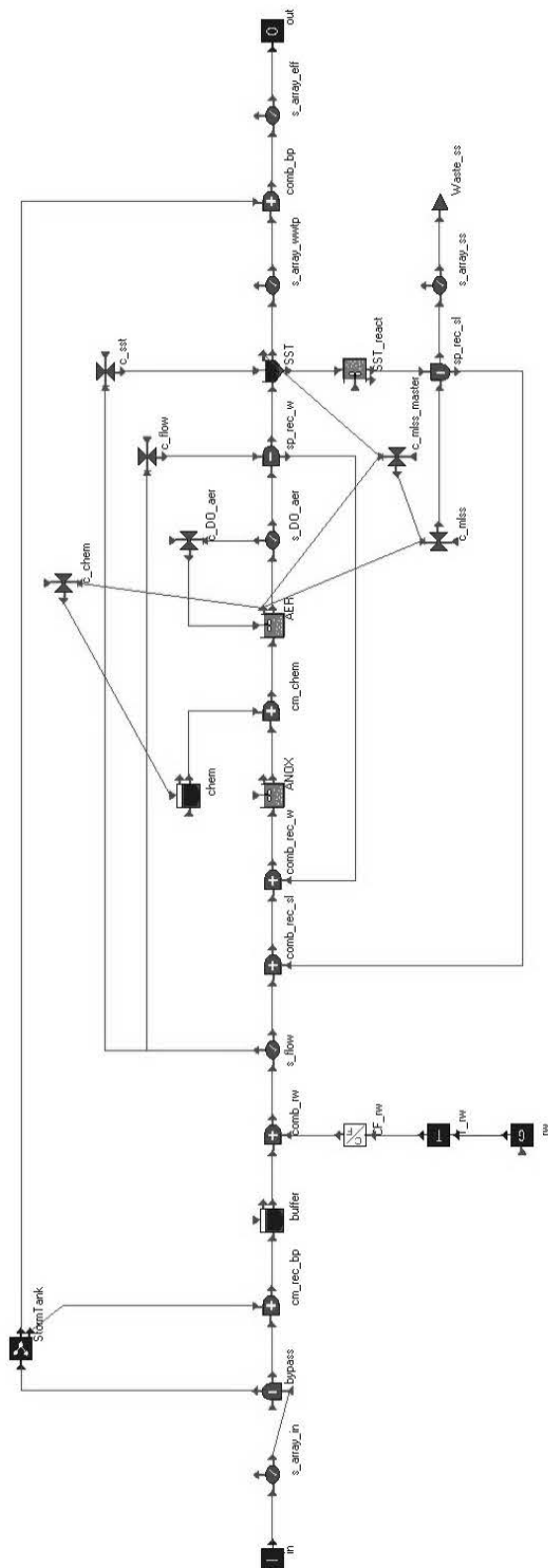

Figure 187: Set-up with cascade sludge wastage control based on ammonia.

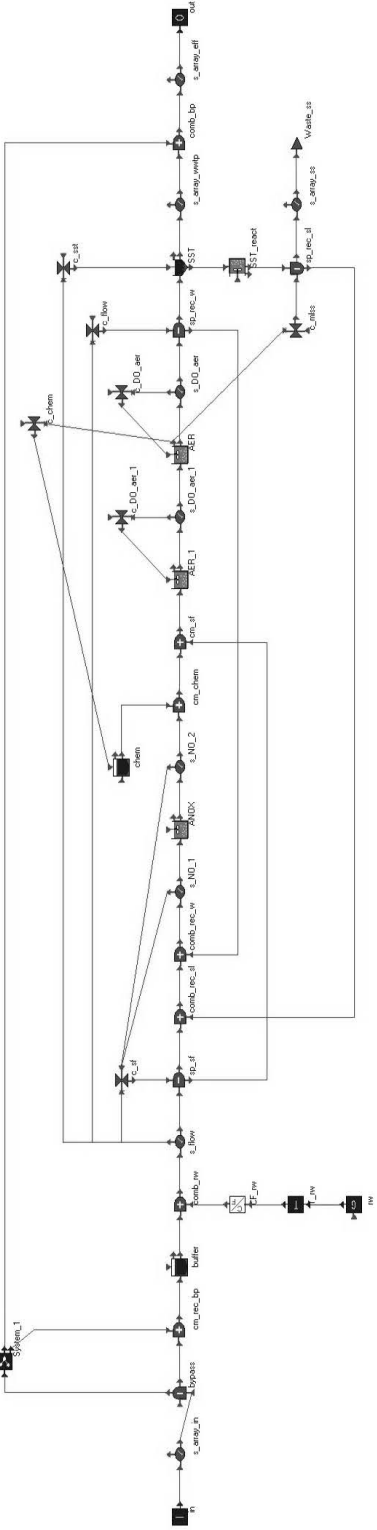

Figure 188: Configuration used in U10, with the possibility for step feed and DO control in the first aerated tank independent from the other aerators.

## U11

### INCREASE IN ANOXIC VOLUME, DECREASE IN AERATED VOLUME

In the previous upgrade scenario, aeration was switched off in the first of the six anoxic tanks during the whole summer period. In this upgrade option, the aeration in the first tank is switched on or off according to a cascade control mechanism which depends on the ammonia concentration in the tank (see Figure 189). When this concentration rises above  $7\text{mgNH}_4\text{-N/l}$ , aeration is switched on by setting the DO controller set-point to  $1.5\text{mgDO/l}$ . The aeration remains on until the ammonia concentration drops below  $5\text{mgNH}_4\text{-N/l}$ . This hysteresis effect was introduced to avoid the master controller from switching the slave DO set-point constantly between 0 and  $1.5\text{mgDO/l}$  when the ammonia concentration is close to the switching point. The DO set-points in the other five compartments of the aerated tank are kept at their original values.

The upgrade scenario was only applied to the Mediterranean set-up, because in the continental case effluent ammonia concentrations would get too high.

For the sake of comparison also two other scenarios were evaluated:

1. the first of the six aerated tanks is permanently turned into an anoxic tank (no aeration)
2. the aeration in all tanks is increased to DO set-points of  $2\text{mg/l}$  for the first five tanks and  $1.5\text{mg/l}$  in the last tank.

## U12

### BUFFERING AMMONIA PEAK LOADS WITH THE STORM TANK

The idea behind this upgrade scenario is to use the storm tank as a temporary influent storage basin whenever it is not needed to fulfil its regular function. To coordinate the filling and emptying of the storm tank in a proper way, multiple mechanisms are necessary (Figure 190) and are described below.

The fraction of the influent that is diverted towards the storm tank in the bypass splitter is controlled on the basis of influent flow rate, influent ammonia measurements and the water level in the storm tank. Just as in the original configuration, the influent flow rate is compared with a pre-set maximum value. To protect the biology and secondary settler from too high flow rates, part of the influent is directed towards the storm tank in case this threshold is exceeded. The same mechanism is used to split the incoming flow in case the on-line calculated ammonia load (i.e. measured ammonia concentration multiplied by flow rate) would exceed the set-point in question.

To avoid the storm tank from being full at the moment that it is needed for its original function, it is not used completely as an ammonia buffer tank. The fraction of the storm tank that can be used as temporary storage basin is set to  $4500\text{m}^3$ , i.e. almost 75% of the total volume of the storm tank. When the current volume in the storm tank exceeds this level, no more water is sent to the tank for ammonia buffering reasons, but only to avoid hydraulic overloading of the plant or spilling to the receiving water.

The mechanism that is used to empty the tank is based on the following decision rules:

- a. the tank should be emptied as soon as possible;
- b. there is a maximum allowed flow rate to be fed to the biology, which should not be exceeded by adding storm tank water to the influent (note that this is the criterion used to fill the tank);
- c. the same holds for an ammonia load threshold;
- d. the tank should only be emptied when there exists a certain nitrification overcapacity.

Rules c and d are ‘ammonia based rules’ and are not applied when the storm tank is filled more than 75% because it is assumed that this indicates storm conditions. In such circumstances it is important to empty the storm tank as soon as hydraulically possible to buffer a possible next storm influent. In reality, the plant operator could of course easily switch these mechanisms on or off according to the weather circumstances or forecasts. This also holds for the criterion of limiting the storm tank use for ammonia buffering purposes to 75% of the total storm tank volume.

Considering the last decision rule, a feedback mechanism was built in to stabilise the controller. The current nitrification overcapacity is estimated on the basis of the influent ammonia load, a rough estimation of the nitrification capacity and an effluent ammonia set-point. This set-point is continuously corrected by a slow proportional integral feedback controller with the effluent ammonia concentration and a fixed set-point as inputs.

Finally one more control feature to improve effluent quality during storm conditions was implemented, namely a bypass around the storm tank. This bypass is used only if the storm tank is completely full and if the ammonia concentration in the storm tank is higher than in the influent. In this way, storm tank water is prevented from being sent directly to the effluent in case it is more concentrated than the storm tank influent.

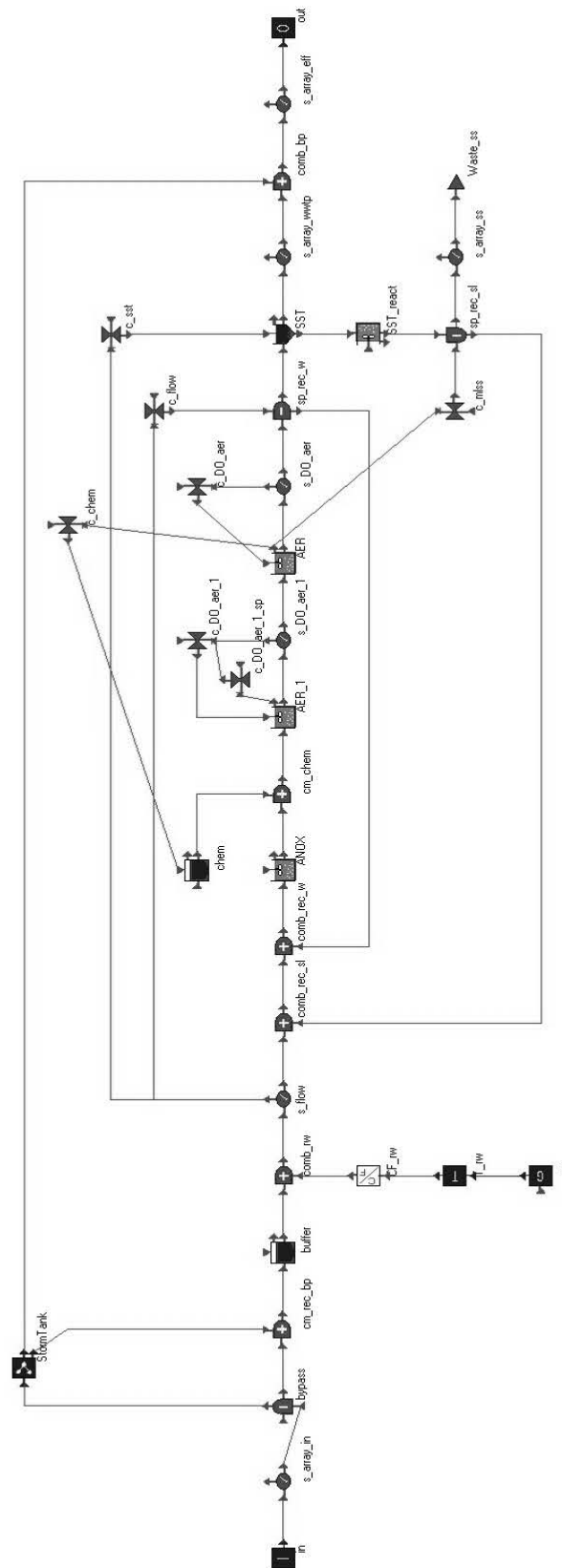

Figure 189: Configuration with cascaded DO control based on ammonia measurements in the first aerated tank.



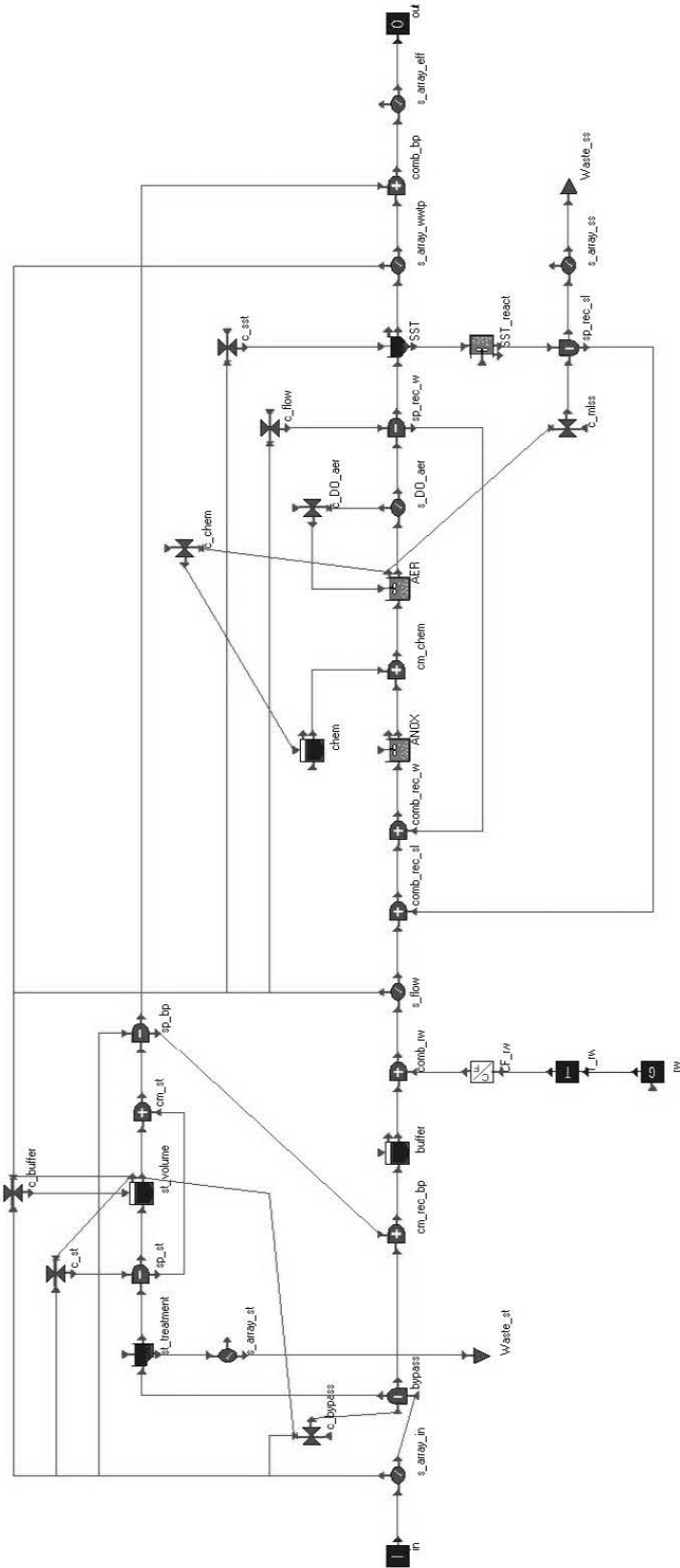

Figure 190: Configuration used in U12, with the possibility to use the storm tank as a controlled buffer to shave influent ammonia peak loads.



## **APPENDIX D**

### **WWTP DIMENSIONED VOLUMES**



WWTP dimensioned volumes

Tank volumes in m<sup>3</sup> for 3.000PE; ST = storm tank, PS = primary settler, SS = secondary settler, ANAER = anaerobic tank, ANOX = anoxic tank, AER = aerobic tank; 'al', 'me', 'oc' indicate the climate for tourist area plants, which require increased volumes.

	ST	PS	SS 1	SS 2	TF	ANAER	ANOX 1	ANOX 2	AER 1	AER 2
A2O	61		123			171	108		540	
A2O al	153		369			512	324		901	
A2O me	183		186			256	243		811	
A2O oc	122		123			171	162		540	
AO	61		123			183			146	
AO al	153		369			548			439	
AO me	183		186			274			219	
AO oc	122		123			183			146	
Biodenipho	61		123			183			316	316
Biodenipho al	153		369			548			949	949
Biodenipho me	183		186			274			949	949
Biodenipho oc	122		123			183			949	949
Biodenitro	61		123						316	316
Biodenitro al	153		369						949	949
Biodenitro me	183		186						475	474
Biodenitro oc	122		123						316	316
HLAS	61	61	123						146	
HLAS al	153	183	369						432	
HLAS me	183	92	186						216	
HLAS oc	122	61	123						144	
LLAS	61		123				157		524	
LLAS al	153		369				471		1,571	
LLAS me	183		186				236		785	
LLAS oc	122		123				157		524	
LLAS PS	61	61	123				219		547	
LLAS PS al	153	183	369				656		1,640	
LLAS PS me	183	92	186				328		820	
LLAS PS oc	122	61	123				219		547	
OD bioP	61		123			183			685	
OD bioP al	153		369			548			2,056	
OD bioP me	183		186			274			1,028	
OD bioP oc	122		123			183			685	
OD simP	61		123						685	
OD simP al	153		369						2,056	
OD simP me	183		186						1,028	
OD simP oc	122		123						685	
UCT	61		123			183	70	141	527	
UCT al	153		369			548	209	424	1,582	
UCT me	183		186			274	104	212	608	
UCT oc	122		123			183	70	141	527	

## Appendix D

Tank volumes in m<sup>3</sup> for 30.000PE; ST = storm tank, PS = primary settler, SS = secondary settler, ANAER = anaerobic tank, ANOX = anoxic tank, AER = aerobic tank; 'al', 'me', indicate the climate for tourist area plants, which require increased volumes.

	ST	PS	SS 1	SS 2	TF	ANAER	ANOX 1	ANOX 2	AER 1	AER 2
A2O	610		1,640			1,706	1,686		4,214	
A2O al	1,220		3,936			4,095	4,045		7,779	
A2O me	1,220		2,440			1,706	2,528		6,321	
AO	610		1,640			1,828			1,463	
AO al	1,220		3,936			4,388			3,510	
AO me	1,220		2,440			1,828			1,463	
Biodenipho	610		1,640			1,828			3,030	3,030
Biodenipho al	1,220		3,936			4,388			7,272	7,272
Biodenipho me	1,220		2,440			1,828			3,030	3,030
Biodenitro	610		1,640						3,030	3,030
Biodenitro al	1,220		3,936						7,272	7,272
Biodenitro me	1,220		2,440						3,030	3,030
HLAS	610	610	1,640						1,463	
HLAS al	1,220	1,220	3,936						3,456	
HLAS me	1,220	1,220	2,440						1,440	
LLAS	610		1,640				1,286		4,285	
LLAS al	1,220		3,936				3,086		10,285	
LLAS me	1,220		2,440				1,286		4,285	
LLAS PS	610	610	1,640				2,113		5,281	
LLAS PS al	1,220	1,464	3,936				5,070		12,675	
LLAS PS me	1,220	610	2,440				2,113		5,281	
OD bioP	610		1,640			1,828			6,060	
OD bioP al	1,220		3,936			4,388			14,543	
OD bioP me	1,220		2,440			1,828			6,060	
OD simP	610		1,640						5,679	
OD simP al	1,220		3,936						13,628	
OD simP me	1,220		2,440						5,679	
UCT	610		1,640			1,828	519	1,212	4,328	
UCT al	1,220		3,936			4,388	1,247	2,909	7,991	
UCT me	1,220		2,440			1,828	519	1,212	4,328	

WWTP dimensioned volumes

Tank volumes in m<sup>3</sup> for 300.000PE; ST = storm tank, PS = primary settler, SS = secondary settler, ANAER = anaerobic tank, ANOX = anoxic tank, AER = aerobic tank.

	ST	PS	SS 1	SS 2	TF	ANAER	ANOX 1	ANOX 2	AER 1	AER 2
<b>A2O</b>	6,100		16,400			17,063	37,207		46,509	
<b>AO</b>	6,100		16,400			18,281			14,625	
<b>Biodenipho</b>	6,100		16,400			22,852			38,053	38,053
<b>Biodenitro</b>	6,100		16,400						38,053	38,053
<b>HLAS</b>	6,100	6,100	16,400						14,625	
<b>LLAS</b>	6,100		16,400				32,219		40,274	
<b>LLAS PS</b>	6,100	6,100	16,400				52,937		52,937	
<b>OD bioP</b>	6,100		16,400			22,852			76,106	
<b>OD simP</b>	6,100		16,400						73,010	
<b>UCT</b>	6,100		16,400			18,281	11,627	34,882	46,509	





## CURRICULUM VITAE

### Personal particulars

Lorenzo Benedetti

° Florence, Italy, 25 July 1974

lorenzo.benedetti@biomath.ugent.be

Italian

married to Franciska Kenig (on 6 November 2001)

father of Viktor Benedetti (° Ghent, Belgium, 18 May 2005)

### Basic education

1993-1999

Faculty of environmental and territorial engineering, University of Florence, Italy.

Thesis title: “Dynamic integrated modelling: a case study on the river Lambro”, developed at BIOMATH, Faculty of bio-sciences engineering, Ghent University, Belgium, in the framework of the Socrates students exchange programme.

### Extra training

Doctoral course on “R&D management”, Faculty of bio-sciences engineering, Ghent University, Belgium, 2003.

### Employment

From January 2003 to date as Research Assistant and Ph.D. student at Ghent University (Belgium), Department of Applied Mathematics, Biometrics and Process Control (BIOMATH).

From November 2001 to December 2002 as independent consultant.

From November 1999 to November 2001 with Enki s.r.l. (Florence, Italy) as founder partner and Director.

### Research stays abroad

7-25 May 2006

South Africa, Durban, Kwa-Zulu Natal University, Chemical Engineering Department.

15-21 July 2006

Canada, Québec, Université Laval, Département de Génie Civil.

## Publications

*Publications in books and in international journals with reading committee:*

Zaher, U., Grau, P., **Benedetti, L.**, Ayesa, E. and Vanrolleghem, P. A. (2007). Transformers for interfacing anaerobic digestion models to pre- and post-treatment processes in a plant-wide modelling context. *Environmental Modelling & Software* 22(1), 40-85.

**Benedetti, L.**, Dirckx, G., Bixio, D., Thoeye, C. and Vanrolleghem, P.A. (2006). Environmental and economic performance assessment of the integrated urban wastewater system. *Journal of Environmental Management* (resubmitted).

De Schepper, V.C.J., **Benedetti, L.**, Holvoet, K.M.A. and Vanrolleghem, P.A. (2006). Extension of the River Water Quality Model N°1 with the fate of pesticides. *Environmental Science and Technology* (submitted).

Ghermandi, A., Vandenberghe, V., **Benedetti, L.**, Bauwens, W. and Vanrolleghem, P.A. (2006) Model-based assessment of the effect of shading on river water quality. *Ecological Engineering* (submitted).

**Benedetti, L.**, Bixio, D. and Vanrolleghem, P.A. (2006). Benchmarking of WWTP design by assessing costs, effluent quality and process variability. *Water Science and Technology* 54(10), 95-102.

**Benedetti, L.**, Bixio, D. and Vanrolleghem, P. A. (2006). Assessment of WWTP design and upgrade options: balancing costs and risks of standards' exceedance. *Water Science and Technology* 54(6-7), 371-378.

**Benedetti, L.**, Dirckx, G., Bixio, D., Thoeye, C. and Vanrolleghem, P.A. (2006). Substance flow analysis of the wastewater collection and treatment systems. *Urban Water Journal* 3(1), 33-42.

Devisscher, M., Ciacci, G., Fé, L., **Benedetti, L.**, Bixio, D., Thoeye, C., De Gueldre, G., Marsili-Libelli, S. and Vanrolleghem, P. A. (2006). Estimating costs and benefits of advanced control for wastewater treatment plants - the MaGIC methodology. *Water Science and Technology* 53(4-5), 215-223.

Claeys, F., Chtepen, M., **Benedetti, L.**, Dhoedt, B. and Vanrolleghem, P. A. (2006). Distributed virtual experiments in water quality management. *Water Science and Technology* 53(1), 297-305.

**Benedetti, L.**, Blumensaat, F., Bönisch, G., Dirckx, G., Jardin, N., Krebs, P. and Vanrolleghem, P. A. (2005). Systems Analysis of urban wastewater systems - two systematic approaches to analyse a complex system. *Water Science and Technology* 52(12), 171-179.

Vanrolleghem, P. A., Rosen, C., Zaher, U., Copp, J., **Benedetti, L.**, Ayesa, E. and Jeppsson, U. (2005). Continuity-based interfacing of models for wastewater systems described by Peterson matrices. *Water Science and Technology* 52(1-2), 493-500.

Vanrolleghem, P. A., **Benedetti, L.** and Meirlaen, J. (2005). Modelling and real-time control of the integrated urban wastewater system. *Environmental Modelling & Software* 20, 427-442.

**Benedetti, L.**, Meirlaen, J. and Vanrolleghem, P. A. (2004). Model connectors for integrated simulations of urban wastewater systems. In: *Sewer Networks and Processes within Urban Water Systems*. J.-L. Bertrand-Krajewski, M. Almeida, J. Matos and S. Abdul-Talib (eds.), *Water and Environment Management Series (WEMS)*, IWA Publishing, pp. 13-21.

Meirlaen, J., Huyghebaert, B., Sforzi, F., **Benedetti, L.** and Vanrolleghem, P. A. (2001). Fast, simultaneous simulation of the integrated urban wastewater system using mechanistic surrogate

models. *Water Science and Technology* 43(7), 301-309.

*Publications in conference proceedings:*

Claeys, F., Chtepen, M., **Benedetti, L.**, De Keyser, W., Fritzon, P. and Vanrolleghem, P.A. (2006). Towards transparent distributed execution in the Tornado framework. In: Proceedings of Environmental Applications and Distributed Computing 2006, Bratislava, Slovakia, 16-18 October 2006.

Solvi, A.-M., **Benedetti, L.**, Vandenberghe, V., Gillé, S., Schlosseler, P., Weidenhaupt, A. and Vanrolleghem, P.A. (2006). Implementation of an integrated model for optimised urban wastewater management in view of better river water quality: A case study. In: Proceedings of IWA WWC 2006, Beijing, China, 10-14 September 2006.

Solvi, A.-M., **Benedetti, L.**, Vandenberghe, V., Gillé, S., Schlosseler, P., Weidenhaupt, A. & Vanrolleghem, P.A. (2006). Construction and calibration of an integrated model for catchment, sewer, treatment plant and river. In: Proceedings of HIC 2006, 7<sup>th</sup> International Conference on Hydroinformatics, Nice, France, 4-8 September 2006.

**Benedetti, L.**, Bixio, D., Claeys, F. and Vanrolleghem, P.A. (2006). Tools to support a model-based methodology for benefit/cost/risk analysis of wastewater treatment systems. In: Proceedings of iEMSs 2006, Burlington VE, USA, 9-13 July 2006.

Claeys, F., De Pauw, D.J.W., **Benedetti, L.** and Vanrolleghem, P.A. (2006). Tornado: A versatile and efficient modeling & virtual experimentation kernel for water quality systems. In: Proceedings of iEMSs 2006, Burlington VE, USA, 9-13 July 2006.

Gernaey, K., Rosen, C., **Benedetti, L.** and Jeppsson, U. (2005). Phenomenological modelling of wastewater treatment plant influent disturbance scenarios. In: Proceedings of 10th International Conference on Urban Drainage (ICUD), Copenhagen, Denmark, 21-26 August 2005.

Solvi, A.-M., **Benedetti, L.**, Gillé, S., Schlosseler, P., Weidenhaupt, A. and Vanrolleghem, P. A. (2005). Integrated urban catchment modelling for a sewer-treatment-river system in Luxembourg. In: Proceedings of 10th ICUD, Copenhagen, Denmark, 21-26 August 2005.

Solvi, A.-M., **Benedetti, L.**, Gillé, S., Schlosseler, P., Weidenhaupt, A. and Vanrolleghem, P. A. (2004). Modélisation d'un bassin versant urbain avec sa rivière en vue de la Directive Cadre Eau. In: Proceedings of 1ères Journées Doctorales en Hydrologie Urbaine, Lyon, France, 25-26 October 2004.

Vandenberghe, V., **Benedetti, L.** and Vanrolleghem, P. A. (2004). Synergetic use of the degrees of freedom to improve the urban waste water system. In: Proceedings of IWA 2004, Marrakech, Morocco, 19-24 September 2004.

**Benedetti, L.**, Krebs, P. and Vanrolleghem, P. A. (2004). Cost-effective development of urban wastewater systems for Water Framework Directive compliance - the CD4WC EU project. In: Proceedings of WaPUG - IMUG International Conference, London, UK, 17 September 2004.

**Benedetti, L.**, Meirlaen, J., Sforzi, F., Facchi, A., Gandolfi, C. and Vanrolleghem, P. A. (2004). Dynamic integrated modelling: A case study on the river Lambro. In: Proceedings of the NOVATECH 2004, Lyon, France, 6-10 June 2004.

### **Congresses and workshops**

HarmoniRiB Workshop. Uncertainty in data and models: On the way to operational use in environmental management, 21 September 2006, Brussels, Belgium.

IWA World Water Congress, 10-14 September 2006, Beijing, China; platform presentation.

iEMSs 2006 Conference, 9-13 July 2006, Burlington, Vermont, USA; platform presentation.

WISA Biennial Conference, 21-25 May 2006, Durban, South Africa; presentation at one-day course.

Course on Uncertainty Assessment, Management and Communication, 7 December 2005  
University of Twente, Holland.

Integrated River Basin Modelling and the EU Water Framework Directive, International Workshop, 17-18 November 2005, Amsterdam, Holland.

Final DayWater Conference and Workshop, 3-4 November 2005, Paris, France.

10<sup>th</sup> International Conference on Urban Drainage, 20-26 April 2005, Copenhagen, Denmark;  
platform presentation.

Workshop on Uncertainty Analysis at EAWAG, 22-26 February 2005, Zurich, Switzerland.

WaPUG-IMUG International Conference, 17 September 2004, London, England; platform  
presentation.

Concepts and Challenges for Integration in Water Resources Management: An International Forum, 14-16 September 2004, North Berwick, Scotland; platform presentation.

NOVATECH 2004, 6-9 June 2004, Lyon, France; platform presentation.

CityNet workshop, 15-18 March 2004, Ghent, Belgium.

19<sup>th</sup> European Junior Scientists Workshop “Process data and integrated urban water modelling”, 11-14 March 2004, Lyon, France; platform presentation.

Industrial biotechnology and sustainable chemistry – perspectives and policy issues, 15 January 2004, Brussels, Belgium.

18<sup>th</sup> European Junior Scientists Workshop “Sewer processes and networks”, 8-11 November 2003, Almogrove, Portugal; platform presentation.

Harmoni-CA workshop “General Methodology for Model Supported Integrated River Basin Management in Europe”, 16-17 June 2003, Potsdam, Germany.

WWWest meeting, 14-16 April 2003, Ghent, Belgium; platform presentation.

International Seminar on In-Sewer Processes, 10 April 2003, Delft, Holland.

CityNet kick-off meeting and workshop, 21-23 February 2003, Paris, France.