

The QUEST initiative anemia study in ESRD: rationale and study protocol

Lucia Del Vecchio¹, Francesco Locatelli²,
Mateus Martins Prata³, Jean Pierre Wauters⁴,
Alicja Dębska-Ślizień⁵, Joan M. Mauri⁶,
Kaj Metsärinne⁷, Gabriel Mircescu⁸,
Kostas C. Siamopoulos⁹, Vianda S. Stel¹⁰, Eric Will¹¹,
Wim Van Biesen¹², Kitty J. Jager¹⁰, Carmine Zoccali¹³

For the QUEST anemia study group*

- ¹ Department of Hypertension and Preventive Nephrology, IRCCS Multimedica, Sesto San Giovanni, Milan - Italy
² Division of Nephrology and Dialysis, Alessandro Manzoni Hospital, Lecco - Italy
³ Division of Nephrology, Santa Maria University Hospital, University of Lisbon, Lisbon - Portugal
⁴ Division of Nephrology and Hypertension, University Hospital of Bern, Bern - Switzerland
⁵ Department of Nephrology, Transplantation and Internal Medicine, Medical University of Gdańsk, Gdańsk - Poland
⁶ Division of Nephrology, University Hospital Dr. J. Trueta, Girona - Spain
⁷ Department of Nephrology, Turku University Central Hospital, Turku - Finland
⁸ "Carol Davila" University of Medicine and Pharmacy, Bucharest - Romania
⁹ Nephrology Department, Medical School, University of Ioannina, Ioannina - Greece
¹⁰ ERA-EDTA Registry, Department of Medical Informatics, Academic Medical Center, Amsterdam - The Netherlands
¹¹ Honorary Renal Physician, Leeds Teaching Hospitals NHS Trust, Leeds - United Kingdom
¹² Renal Division, University Hospital Ghent, Ghent - Belgium
¹³ CNR-IBIM, Clinical Epidemiology and Physiopathology of Renal Disease and Hypertension & Unit of Nephrology, Dialysis and Renal Transplant, Ospedali Riuniti, Reggio Calabria - Italy

Key words: Anemia, Chronic kidney disease, Erythropoiesis-stimulating agents, Kidney transplant, Mortality

INTRODUCTION

Do we need another study on anemia and erythropoiesis-stimulating agents in hemodialysis?

The effectiveness of erythropoiesis-stimulating agents (ESAs) to correct renal anemia has been one of the great advancements in the last 2 decades of renal replacement therapy (RRT) (1). Quality of life of patients on RRT has improved substantially with the advent of ESAs (2, 3), and a major reduction in the need of blood transfusions is an undeniable, concrete benefit of ESA therapy. However, even after intense research on ESAs and their use to achieve an optimal hemoglobin (Hb) target capable of improving patient outcome, some key points are yet to be clarified (4), as was recently underlined by some recent trials (5, 6) and a meta-analysis (7).

The need for optimal ESA use is amplified by the fact that these agents are quite expensive. In the United States, e.g., expenditures for ESAs have doubled from \$0.9 billion to \$1.9 billion over the last 5 years, whereas the overall level of expenditure for care has remained stable. As health care budgets are not endlessly expandable, greater use of ESAs will necessarily compete with health care expenditures related to other potentially interesting treatments or drugs. In some countries, it might result in limited availability of ESAs or other drugs, or in the restriction of the use of certain drugs to specified patient groups. A scenario where the introduction of newer agents such as cinacalcet, or support for important strategies like setting up screening programs for chronic kidney disease (CKD), or educational programs on CKD for general practitioners, are barred by governments or health care providers appears not unrealistic. Thus the increased expenditure needed to achieve

higher Hb target can be afforded by national health systems only if it is counterbalanced by a clear benefit.

We as a nephrology community have an important responsibility in maintaining the appropriate usage of these agents. It is fundamental that our community provides data proving that indeed we do make best use of the money spent, to avoid having financing bodies themselves impose rules on us for how we use these agents. Until now, extensive recent data on the nature and extent of parameters causing overusage or inappropriate usage of ESAs in CKD stage 5 patients are lacking. Available observational studies have focused mainly on the degree of achievement of Hb correction, rather than on a mechanistic or in-depth analysis of the relation between dose of ESA and Hb level achieved, or these studies date from the pre-guidelines era (8-10). The ESAM study (11), published shortly after the development of the European Best Practice Guidelines (EBPG) on anemia management (12), demonstrated that in 2003, only 66% of patients achieved the goals set by the EBPG. Also in the Dialysis Outcomes and Practice Patterns Study (DOPPS) (9), it was apparent that only around 60% of the patients surveyed in different European dialysis centers achieved recommended Hb levels. More importantly, whereas observational studies give us a clue regarding how many patients achieve the targets, they leave us unaware of the underlying “efforts” in terms of ESA dosage used to obtain these Hb levels. It is striking that in DOPPS, e.g., the dosage of ESA used in the United States was twice that of European centers, despite the achievement of the same hemoglobin levels (9). In addition to a likely different burden of comorbidities between the 2 populations, there appear also to be policy-related factors besides so-called patient-related hyporesponsiveness factors that have a substantial impact on the usage of ESAs.

A well-performed observational study is thus needed to analyze factors that lead to inefficient ESA use. This will probably help not only in identifying those patients who are more likely to benefit from higher Hb targets, but also to rationalize ESA expenditures and thus reduce the cost of treatment.

A second problem relating to the use of ESAs is the recommended level of correction. Recent randomized controlled trials (RCTs) found no significant effect (6) or even a higher mortality risk in patients randomized to complete anemia correction (5). This has raised concern that the upper level of the Hb target (e.g., 13 g/dL) is too high, as can be seen in the latest revision of the Kidney/Dialysis Outcomes Quality Initiative (K/DOQI), which will propose reducing the level to 12 g/dL. However, circumstances in RCTs of CKD stages 3 and 4 and end-stage renal disease (ESRD) cannot

be simplistically equated to those encountered in everyday clinical practice. To start with, it is quite striking that the mortality in large RCTs is far below that observed in non-study populations. For example, in a RCT on the effect of correction of lipid disturbances in diabetic dialysis patients in Germany (the 4D study) by Wanner et al (13), the mortality observed in the intervention group was not different from that observed in the placebo group, but was only half that observed in the general German dialysis population. The same holds true for the Cardiovascular Risk Reduction by Early Anemia Treatment with Epoetin Beta (CREATE) trial (6): in which, after a mean follow-up of approximately 3 years, 105 patients had had a first cardiovascular event. This cardiovascular event rate was only half the rate to be expected. The selection effects of RCTs together with the impact of being studied seem to distort the “real” effect of interventions and hamper the generalizability of study results to broad patient populations. This suggests at least that some factors relating to general care of ESRD patients are not satisfactorily taken care of in everyday practice (14). In this regard, it is of interest that in the quality assessment part of DOPPS, some centers do perform well on a particular parameter A, but not on B, whereas others perform well on parameter B but not on A, and that only a very limited number of centers comply with all investigated quality assessment parameters (15). For these reasons, an observational study that registers all practices related to anemia management on a large (European) scale, and which allows us to link this to achieved clinical outcomes – defined as ESA use, anemia correction obtained and mortality/morbidity outcome – can give important information to unravel the hidden factors determining differences between good and less good clinical practice. In addition, we hope and believe that merely the fact of registering the parameters for a benchmarking goal might already, just as in a clinical trial, have a positive impact.

A second problem is that in randomized controlled trials, patients should reach a given Hb concentration according to their randomization arm. This might lead to the situation that some patients who would normally not obtain a full correction of their anemia to, let's say, an Hb of 13 g/dL, are “forced” with all means available to obtain this goal, whereas in everyday clinical practice, the clinician would have been satisfied with an Hb of 11.5 g/dL. Forced treatment targets may expose patients with a frail cardiovascular conditions and/or diabetes to an unwarranted high-risk level. In the meta-analysis by Phrommintikul et al (7), the 2 trials that found an increased mortality risk with randomization to normal Hb levels enrolled a much higher percentage of diabet-

ics compared with the other trials included in the analysis. A third problem, which applies to both RCTs and everyday clinical practice, is that there is a difference between aiming toward and actually achieving a certain Hb level. It is impossible to exactly predict the Hb level that will be obtained in a patient after a certain ESA dose, so we will always end up with a range – with a mean value and with a standard deviation of, let's say, 0.5 g/dL. If we set 12 g/dL as the desirable Hb level to be achieved in all patients, this means that to have 97.5% of patients above 12 g/dL, we are bound to accept a mean Hb value of 13 g/dL, and also that 50% of the population will be between 13 and 14 g/dL. In addition, once we achieve a certain Hb level with ESA treatment, this level will not be stable over time. Indeed, drifting and undulating of Hb levels have recently been recognized as a possible factor influencing patient outcome (16). However, no RCT has yet taken this issue into account.

A last problem of RCTs is that patients should be equal in all parameters, except 1 – the intervention. However, it is clear that in medicine, and especially in patient groups with a high burden of comorbidity, only a few factors do have so strong an effect on their own that they can make a real difference in outcome. It is thus no real surprise to see that it is difficult to obtain significant differences in outcome if you are only allowed to have 1 parameter that is different between 2 groups. Once again, it appears that the picture obtained by a well-balanced observational study might be more realistic than that seen through the myopic glasses of a randomized controlled trial.

For all these reasons, we believe that a large European registry of anemia management in hemodialysis patients, and the factors relating to underachievement of targets in this regard, both at the patient level (hyporesponsiveness) and at the center level (anemia management policies) is still of great importance.

STUDY PROPOSAL FOR STRATEGIES FOR ANAEMIA CORRECTION AND USE OF ERYTHROPOIESIS-STIMULATING AGENTS IN DIALYSIS PATIENTS

A cross-sectional prospective observational study

This first study proposes to evaluate, in a multicenter cross-sectional observational study, the prevalence and distribution of anemia and its treatment in a large European dialysis population. In the participating units, all

patients treated by dialysis (hemodialysis [HD] and peritoneal dialysis [PD]) for at least 6 months will be evaluated. During a 2-month observation period including 3 measurements, treatment by erythropoiesis-stimulating agents (ESAs) and parameters potentially related to ESA hyporesponsiveness and underachievement of anemia correction at center level will be investigated. Routine center policies for anemia surveillance and management and administrative regulations will also be recorded. As part of a quality management program, the same evaluation will be repeated after 1 year in the same centers.

Introduction

Anemia is a common and well-recognized problem in patients with ESRD on dialysis. Over the last 2 decades, treatment of renal anemia has been substantially improved by the introduction of ESAs. Whereas treatment with ESAs is quite effective in correcting Hb levels in most patients, still some important problems remain. To start with, ESAs are quite expensive, which limits their availability in some countries. Existing data suggest that doses needed to obtain “normal” Hb levels (>12 g/dL) are exponentially higher than those needed to obtain the lower Hb levels (between 10 and 12 g/dL) characterized by some studies to be beneficial.

In addition, it is clear that some patients need far larger doses of ESAs to achieve a target Hb level than others, and for some patients, even with very high doses of ESA, no correction of Hb can be obtained. For these patients, defined as ESA-resistant (>300 U/kg per week), malnutrition and inflammation, in addition to comorbidities, have been proposed as important factors influencing response to ESA. However, little is known still about the epidemiology of ESA hyporesponsiveness in Europe, and its causes have not been yet fully elucidated. The need to optimize the use of ESAs is evident. As a nephrology community, facing a constant growth in dialysis and predialysis populations, there is a responsibility to optimize the use of ESAs to make the cost of therapy sustainable in the future.

Aim of the project

1. Identify the relative contribution of different factors that hamper optimal correction of anemia in dialysis patients by investigating
 - the prevalence and distribution of anemia in a large European dialysis population;
 - the degree of anemia correction obtained and the

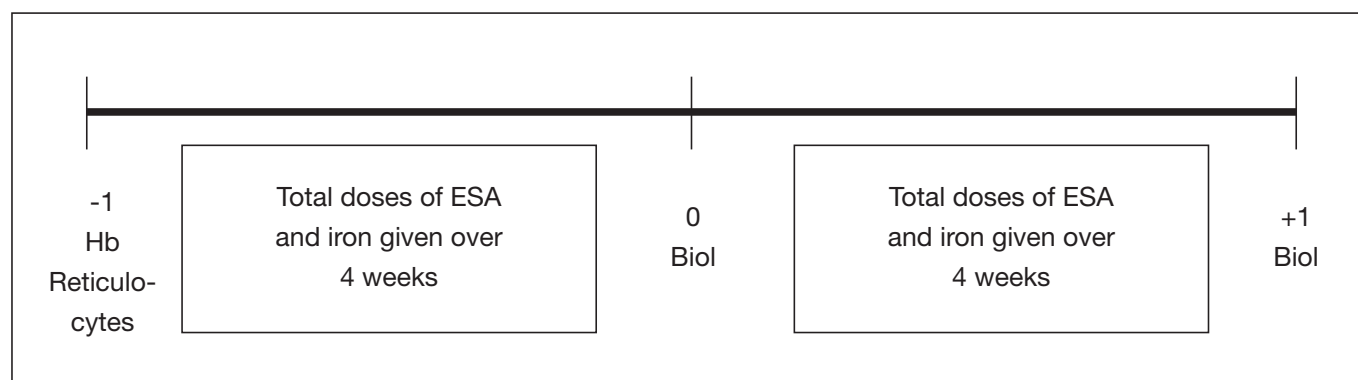

Fig. 1 - Time chart for records and measurement of anemia parameters.

use and dosage patterns of ESAs;

- the prevalence of ESA hyporesponsiveness (i.e., >300 U/kg per week) (considered as a continuous and as a categorical variable) and its underlying causes at patient level;
- the factors that may explain differences in anemia correction and/or ESA hyporesponsiveness at a national, regional and/or center level.

2. Set up an instrument that will allow us to improve anemia management at the individual patient and center level.

It is anticipated that, as part of a quality improvement program, the return of the results to the participating centers will also allow each of them to optimize their anemia management at the levels of individual patient and center care. Therefore, the same evaluation will be conducted after 1 year in the same participating centers.

Study design

This QUEST (Quality European Studies) project is a cross-sectional observational study that will register the following, in all dialysis patients treated in the participating units:

- anemia parameters (retrospectively, for months -1 and 0, and prospectively at month +1) and doses of ESA and iron given (total doses given during 4 weeks from month -1 to 0, and 0 to 1) (Fig. 1);
- comorbidities and parameters potentially related to ESA hyporesponsiveness;
- center policies for anemia management during the investigated period.

After 12 months, the time 0 evaluation will be repeated in the same centers according to the same inclusion and exclusion criteria.

Center and patient inclusion criteria

Based on the nationalities of the Anaemia Working Group members (Tab. I), units of each of the 12 represented countries will be included in the study (plus Germany and Austria, and extension of Estonia to the Baltic States and of Finland to the Scandinavian countries). This geographical partition represents a balance between western and central Europe and includes most of its large countries. The target number for inclusion of patients is 3,500.

For each participating country, a list of dialysis centers should be made available to the study group. A stratified randomization of centers will be performed to obtain a representative participation of university, large regional and small regional centers. In each center, all patients should be included in the study.

The working group members will act as study counselors at the national level and verify the time schedule at the participating units.

In addition, a part-time study coordinator and a part-time data(base) manager will be hired.

Each participating center should commit itself to include all its patients treated by dialysis (HD and PD) for at least 6 months. In return, they will receive 20 euros per completed patient file.

Local ethics committee approval and patient informed consent forms may be requested depending on the national and/or local regulations. In cases where an informed consent form is mandatory at the local level, the number of patients refusing to participate should not exceed 10% of the total number of treated patients. If this percentage is exceeded, another center should be asked to participate.

Study protocol

Parameters to register:

A. Individual patient data

1. Demographic data

- Sex
- Ethnicity
- Age
- Weight, height
- Type of renal disease (according to EDTA Registry coding)
- Diabetes: yes/no
- Time on dialysis: months
- Dialysis modality (HD vs. hemodiafiltration [HDF] vs. PD)

2. Hematologic data

- Hemoglobin and reticulocyte count at the beginning of the months -1, 0 and +1 (midweek predialysis sample for hemodialysis patients and 3 values measured during the last – if possible, monthly – consultations for PD patients)

3. Potential causes of ESA resistance:

- Iron storage parameters: ferritin, serum iron and serum transferrin (to calculate transferrin saturation)
- Serum albumin (+ determination method in center questionnaire)
- C-reactive protein (CRP)
- Intact parathormone (PTH) level (last measured value, <6 months before study)
- Kt/V urea (last measured value, <3 months before study): for HD, value/session; for PD, value/week
- Residual renal function (last measured creatinine clearance in ml/min)
- Type of hemodialysis access: arteriovenous shunt, polytetrafluoroethylene graft, biological graft, transient or permanent catheter
- Aggravating clinical factors during the preceding 3 months: infection, malignancy, episodes of bleeding, surgery, hospitalization etc.

4. Therapeutic data

- Use of ESA: yes/no
 1. agent: epoetin-alpha, epoetin-beta, darbepoetin,

TABLE I
QUEST-ANAEMIA WORKING GROUP MEMBERS

Clinical area experts	Country	Position	E-mail address
F. Locatelli	Italy	Chair	nefrologia@ospedale.lecco.it
M. Martins Prata	Portugal	Co-chair	martins.prata@hsm.min-saude.pt
J.P. Wauters	Switzerland	Co-chair	Jean-Pierre.Wauters@insel.ch
L. Del Vecchio	Italy	Secretary	luciadelvecchio@yahoo.com
W. Van Biesen	Belgium	Secretary	wim.vanbiesen@ugent.be
J. Arrieta	Spain		jarrieta@hbas.osakidetza.net
C. Bovy	Belgium		cbovy@yahoo.com
A. Debska-Slizien	Poland		adeb@amg.gda.pl
K. Leunissen	The Netherlands		kle@sint.azm.nl
A. MacLeod	United Kingdom		mmd175@abdn.ac.uk
J. Mauri	Spain		nefrologia@htrueta.scs.es
K. Metsärinne	Finland		kaj.metsarinne@tyks.fi
G. Mircescu	Roumania		gmircescu@hotmail.com
K. Siamopoulos	Greece		ksiamop@cc.uoi.gr
E. Villar	France		emmanuel.villar@chu-lyon.fr
A. Wiecek	Poland		awiecek@spskm.katowice.pl
E. Will	United Kingdom		Eric.Will@leedsth.nhs.uk
Registry experts			
C. Gronhagen-Riska	Finland		carola.gronhagen-riska@hus.fi
M. Ots	Estonia		Mai.Ots@kliinikum.ee
V. Stel	ERA/EDTA Registry		v.s.stel@amc.uva.nl

other ...

2. total administered dose during two 4-week periods (months -1 to 0 and 0 to 1) (raw units/weights; a conversion factor for darbepoetin-alpha will be applied centrally)
3. administration route: subcutaneous or intravenous
4. administration frequency: days/week or days/month
5. start of ESA : <3 months, between 3 and 6 months, >6 months before data collection

- Iron administration: yes/no
 1. agent: saccharate, dextran, gluconate, other ...
 2. total administered dose over each of the two 4-week periods
 3. administration route: intravenous or peroral
 4. administration frequency: days/week or days/month, on demand
- Units of transfused packed cells during the months -1 and 0
- Oral anticoagulants: yes/no
- Platelet inhibitors: yes/no
- Angiotensin-converting enzyme inhibitors and/or angiotensin receptor blockers: yes/no

B. Center data

1. Center policy
 - Recommended type and mode of ESA administration
 - Type of guidelines followed or presence of specific center policies
 - Use of iron storage parameters and dosage; iron administration and policy in interval prior to serum iron parameter sampling
 - Routine vitamin C and/or folic acid administration
 - Management of anemia parameters on a daily basis: nephrologist, dialysis nurse, dedicated nurse
2. Use of management software tools and/or database
3. National/regional policy for ESA prescription
4. National/regional policy for ESA reimbursement

Statistical analysis

Statistical analysis will include

1. descriptive analysis of the data, at the individual center, country and European levels (mean and/or median, with 25th and 75th percentiles, as appropriate)
2. comparisons of relevant subgroups according to sex, dialysis modality, access type, ESA agent, route of administration of ESA, country etc. These analyses will

be performed by *t*-test, Mann-Whitney test or 1-way ANOVA, as applicable.

3. univariate and multivariate regression analysis of different continuous variables (Hb, ESA dose, age, months on dialysis, iron parameters, CRP, residual renal function, PTH) with ESA dose, and Hb levels achieved.

To avoid interference with “loading dose” problems, patients treated with ESA for less than 6 months will be analyzed separately.

For all statistical investigations and their results, it will be kept in mind that these should be considered as hypotheses generating associations, and that these may not be causal.

APPENDIX

*QUEST Anemia Study Group: C. Zoccali and K. Jager (QUEST co-chairs), F. Locatelli (chair), M. Martins Prata (co-chair), J.P. Wauters (co-chair), L. Del Vecchio (secretary), W. Van Biesen (secretary), A. Dębska-Ślizień, J.M. Mauri, K. Metsärinne, G. Mircescu, K.C. Siamopoulos, V.S. Stel, E. Will (members).

ACKNOWLEDGEMENTS

The Quest project is funded by ERA-EDTA. The Anemia Project is financially supported by an unrestricted grant from Amgen.

Conflict of interest statement: None declared.

Address for correspondence:

Lucia Del Vecchio, MD
Department of Preventive Nephrology
and Hypertension
IRCCS Multimedica
Via Milanese 300
Sesto San Giovanni, Milano, Italy
luciadelvechio@yahoo.com

REFERENCES

1. Adamson JW, Eschbach JW. Erythropoietin for end-stage renal disease. *N Engl J Med* 1998; 339: 625-7.
2. Furuland H, Linde T, Ahlmen J, Christensson A, Strombom U, Danielson BG. A randomized controlled trial of haemoglobin normalization with epoetin alfa in pre-dialysis and dialysis patients. *Nephrol Dial Transplant* 2003; 18: 353-61.
3. Moreno F, Sanz-Guajardo D, Lopez-Gomez JM, Jofre R, Valderrabano F. Increasing the hematocrit has a beneficial effect on quality of life and is safe in selected hemodialysis patients. Spanish Cooperative Renal Patients Quality of Life Study Group of the Spanish Society of Nephrology. *J Am Soc Nephrol* 2000; 11: 335-42.
4. Besarab A, Bolton WK, Browne JK, Egrie JC, Nissenson AR, Okamoto DM, Schwab SJ, Goodkin DA. The effects of normal as compared with low hematocrit values in patients with cardiac disease who are receiving hemodialysis and epoetin. *N Engl J Med* 1998; 339: 584-90.
5. Singh AK, Szczech L, Tang KL, Barnhart H, Sapp S, Wolfson M, Reddan D; CHOIR Investigators. Correction of anemia with epoetin alfa in chronic kidney disease. *N Engl J Med* 2006; 355: 2085-98.
6. Drueke TB, Locatelli F, Clyne N, Eckardt KU, Macdougall IC, Tsakiris D, Burger HU, Scherhag A; CREATE Investigators. Normalization of hemoglobin level in patients with chronic kidney disease and anemia. *N Engl J Med* 2006; 355: 2071-84.
7. Phrommintikul A, Haas SJ, Elsik M, Krum H. Mortality and target haemoglobin concentrations in anaemic patients with chronic kidney disease treated with erythropoietin: a meta-analysis. *Lancet* 2007; 369: 381-8.
8. Collins AJ, Li S, St Peter W, Ebben J, Roberts T, Ma JZ, Manning W. Death, hospitalization, and economic associations among incident hemodialysis patients with hematocrit values of 36 to 39%. *J Am Soc Nephrol* 2001; 12: 2465-73.
9. Locatelli F, Pisoni RL, Combe C, Bommer J, Andreucci VE, Piera L, Greenwood R, Feldman HI, Port FK, Held PJ. Anaemia in haemodialysis patients of five European countries: association with morbidity and mortality in the Dialysis Outcomes and Practice Patterns Study (DOPPS). *Nephrol Dial Transplant* 2004; 19: 121-32.
10. Volkova N, Arab L. Evidence-based systematic literature review of hemoglobin/hematocrit and all-cause mortality in dialysis patients. *Am J Kidney Dis* 2006; 47: 24-36.
11. Jacobs C, Frei D, Perkins AC. Results of the European Survey on Anaemia Management 2003 (ESAM 2003): Current status of anaemia management in dialysis patients, factors affecting epoetin dosage and changes in anaemia management over the last 5 years. *Nephrol Dial Transplant* 2005; 20 (Suppl 3): S3-24.
12. Working Party for European Best Practice Guidelines for the Management of Anaemia in Patients with Chronic Renal Failure. European best practice guidelines for the management of anaemia in patients with chronic renal failure. *Nephrol Dial Transplant* 1999; 14 (Suppl 5): S1-50.
13. Wanner C, Krane V, Marz W, Olschewski M, Mann JF, Ruf G, Ritz E; German Diabetes and Dialysis Study Investigators. Atorvastatin in patients with type 2 diabetes mellitus undergoing hemodialysis. *N Engl J Med* 2005; 353: 238-48.
14. Lacson E Jr, Ofsthun N, Lazarus JM. Effect of variability in anemia management on hemoglobin outcomes in ESRD. *Am J Kidney Dis* 2003; 41: 111-24.
15. Port FK, Pisoni RL, Bragg-Gresham JL, Satayathum SS, Young EW, Wolfe RA, Held PJ. DOPPS estimates of patient life years attributable to modifiable hemodialysis practices in the United States. *Blood Purif* 2004; 22: 175-80.
16. Regidor DL, Kopple JD, Kovesdy CP, Kilpatrick RD, McAllister CJ, Aronovitz J, Greenland S, Kalantar-Zadeh K. Associations between changes in hemoglobin and administered erythropoiesis-stimulating agent and survival in hemodialysis patients. *J Am Soc Nephrol* 2006; 17: 1181-91.

© Società Italiana di Nefrologia